

THE UNIVERSITY  
OF ILLINOIS  
LIBRARY

720.5  
BU  
v. 74



collated OK

h-18c

# THE BUILDING NEWS

AND

ENGINEERING JOURNAL.

---

VOLUME THE SEVENTY-FOURTH.

---

JANUARY TO JUNE, 1898

---

PUBLISHED FOR THE STRAND NEWSPAPER CO., LIMITED, BY E. J. KIBBLEWHITE, MANAGING DIRECTOR,

AT THE OFFICE OF THE "BUILDING NEWS,"

332, STRAND, LONDON, W.C.

UNIVERSITY OF ILLINOIS  
LIBRARY  
LIBRARY

# INDEX TO VOL. LXXIV.

[For Index to Illustrations see page VI.]

**ABBEY** mansions accident, Westminster, 621, 623, 668, 702, 736, 763, 887  
**Abbeys**: Bourne, 270; Paisley, 126; Westminster (architect to) 325 (brasses in) 692; Whitby, 527  
**Aberdeen society of architects**, 303  
**Academy architecture**, 3  
**Academy, royal**: architecture at, 587, 623; drawings, 199; elections, 112, 183; Millais' pictures at, 2; pictures at, 587, 624, 659, 695  
**Academy, royal Scottish**, architecture at, 333  
**Accounts for architects**, 152  
**Acetylene gas**, 336  
**Acton sewage**, 621  
**Adjoining owner**, 533  
**Admixtures, cement**, 299  
**Advertising diocesan surveyor, an**, 325  
**Aitchison, Prof. Geo., R.A.**, 112, 188, 876  
**Allan, Archibald, Govan**, the late, 303  
**Almshouse, Taunton**, 706  
**Amalgamated society of carpenters and joiners**, 558  
**Amendment of law as to new streets, proposed**, 48  
**Amendments to London Building Act, 152**, 585  
**Amenities of towns**, 907  
**American**: and English steel construction, 735; domestic architecture, 554; government buildings, 439; public schools, 340  
**Amiability, the apotheosis of**, 188  
**Ancient**: buildings, society for protection of, 886; Southampton, 586  
**Angels, Italian painters'**, 377, 548  
**Animal studies**, 9, 127, 231, 343, 489, 635, 887  
**Antiquarian society, Lancashire and Yorkshire**, 850  
**Apotheosis of amiability**, 188  
**Appeal**: board of building, Boston, 79; under Public Health Act, 182  
**Apprenticeship deeds, plumbers'**, 325  
**Aquarium, art metalwork exhibition at**, 741, 771; awards, 811  
**Arbitrations**: Great Smith-st., Westminster, 798; Harrogate waterworks, 182, 252; Lampeter, 513; Marlborough-gate (Central railway) 252; Paddington (London School Board) 512; Putney, 871; Rhyl, 182; Stockwell, 620; Tower Bridge approach, 438  
**Arbitrators, surveyors as**, 123, 193  
**Arbroath water supply**, 438  
**Archæological institute, royal**, 799  
**Arches in concrete, construction of**, 157  
**Architect**: acquitted of manslaughter, 763, 887; and builder, squabble between, 512; divorced, 438; timber merchant's action against, 220  
**Architects**: accounts for, 152; and surveyors (Sheffield socy.) 198, 341; artistic copyright for, 484, 597; assistants and Workmen's Compensation Act, 836; benevolent society, 338; British, royal institute of, 116, 188, 261, 341, 405, 483, 553, 596, 654, 698 (election of council) 690, 692, 812 (presidency) 471, 473, 483 (prize drawings) 82, 85, 117 (royal gold medal) 188, 250, 291, 324, 876; certificate, finality of, 513; claim, 292; dispute between, 221; electric lighting, notes for, 122, 194, 226, 298, 406, 486, 520, 630, 662, 842, 880; instructions to, 115; hat, and the unseen wire, 437; licensing of, in Illinois, 47, 252, 561; photography for, 548; registration (bill) 399 (society of architects and) 397, 450, 485; responsibilities and registration, 799; societies (Aberdeen) 303 (Bristol) 582, 618, 691 (Manchester) 303; society of, the, 152, 269, 444, 523, 770 (and registration question) 397, 450, 485 (dinner) 591  
**Architectural**: associations (Birmingham) 341 (Edinburgh) 146, 229, 397, 470, 547,

691, 813 (Glasgow) 90, 160, 303, 691, 850 (Ireland) 60, 146, 229, 763 (London) 82, 192, 297, 372, 445, 592, 664, 735 (dinner) 769 (soirée) 657; crafts, progress of, 1; curiosity, 510; metalwork, 811; museum, royal, 845; photography, 633; societies (Edinburgh) 198, 269, 691, 813 (Exeter) 341, 691 (Leeds and Yorkshire) 160, 198 (Liverpool) 582, 706 (York) 434; studies, composition in, 112  
**Architecture**: academy, 3; at royal academy, 587, 623; at royal Scottish academy, 333; domestic, in Eastern States of America, 554; Egypt, the birthplace of, 261; English church, progress of art in, 124; history of, for the student, 124; Later Renaissance, in England, 597; Scottish church, 372; v. building, 399  
**Architrave and lintel, stone**, 778  
**Arc lighting**, 880  
**Argyllshire, early sculptures of**, 113  
**Art**: discovering talent in, 295; English, in 18th century, 883; gallery (Manchester) 57; metalwork exhibition at Aquarium, 741, 771 (awards) 811; natural, 731; progress of, in English church architecture, 124; Tolstoi on, 47  
**Artificial stone**, 251  
**Artisans' dwellings, Brighton**, 271  
**Artistic copyright for architects**, 484, 597  
**Artists**: benevolent institution, 691; British, society of, 441  
**Arts**: and crafts institute, Camberwell, 6; decorative, reference books on, 89, 118; fine, sanitation and the, 558  
**Assistants, architects', and Workmen's Compensation Act**, 836  
**Associations**: architectural (Birmingham) 341 (Edinburgh) 146, 229, 397, 470, 547, 691, 813 (Glasgow) 90, 160, 303, 691, 850 (Ireland) 60, 146, 229, 763 (London) 82, 192, 297, 372, 445, 592, 664, 735 (dinner) 769 (soirée) 657; building trades (Manchester and Salford) 470; clerks of work's, 228; district surveyors' (dinner) 846; home arts and industries, 325; master builders' (Bath) 198 (Brighton) 561 (Bristol) 160 (Coventry) 618 (Crewe) 691 (Dublin) 90 (National) 149 (Newcastle) 618 (Nottingham) 146, 198 (Portsmouth) 229; master painters' (Border Counties) 183; master wrights' (Glasgow) 654; sanitary inspectors' 5, 269, 691; slaters', National, 706; waterworks engineers', British, 654, 763  
**Assurance companies**: Guardian, 364; Prudential, 364  
**Asylums, lunatic**: Coxlodge, Newcastle, 304; Hellingby, East Sussex, 705; Holly Moor, Birmingham, 7, 343, 510, 547; West Bangour, 126  
**Atherton and Dolman, in re**, 110, 907  
**Attic rooms**, 8  
**Auctioneers' institute**, 47, 397, 706  
**Authorities**: burial and purchases of land, 907; urban, and fair wages, 586  
**Awards, art metalwork exhibition**, 811

**BACTERIOLOGICAL** analyst not officially recognised, 514  
**Banks**: Fleet-st. (Barclay's) 635; Leeds (N. P.) 218; Loughborough, 60; Nuneaton, 706; Stratford-on-Avon, 546  
**Barnmouth water supply**, 872  
**Barracks, Shorncliffe**, 472  
**Barwell, Jas., Birmingham**, the late, 450  
**Basement vault, Marylebone, collapse of**, 810  
**Basis of design**, 374  
**Bath**: city architects in litigation, 292, 584; master builders' association, 198  
**Baths**: Battersea, 563; Finchley-road, Hampstead, 582; Glasgow, 508; Leeds, 508; New Cross, 180; Romford, 704; swimming, heating of, 701; Waltham-

stow, 8, 59, 91, 111; Walworth, 508; Wimbledon, 851; Winchester, 671, 813  
**Bear, Drew, v. St. Pancras guardians**, 77, 110, 147, 251  
**Bedells, Chas. King, the late**, 5  
**Bending moment**, 398  
**Benevolent**: institutions (artists') 691 (builders' clerks') 261 (do., dinner) 485; society, architects', 338  
**Benwell, building estate at**, 885  
**Birmingham**: architectural assocn., 341; Welsh water supply, 727  
**Blackpool building by-laws**, 148  
**Bland, J., Birmingham**, the late, 704  
**Blundell v. Price, main drain or sewer**, 620  
**Blundering of Mold U.D.C.**, 584  
**Board schools**: and depreciation of adjoining property, 871; Bristol (higher grade) 705; Carlisle, 91; Chesterfield, 231; Colne, Lancs., 91; Highworth, 762; London, improvement of, 399; Scarborough (higher grade) 707; Weston-super-Mare, 671  
**Bolted v. riveted joints**, 523  
**Bombay, sanitary works at**, 78  
**Bo'ness water supply**, 78  
**Books, reference, on ornament and decorative arts**, 89, 118  
**Boston, Mass., board of building appeal**, 79  
**Botanical beds in London parks**, 729  
**Boundary walls and building act**, 871  
**Bradshaw v. Buchanan, brickmaking royalties**, 727  
**Brasses, monumental, in Westminster abbey**, 692  
**Breweries, book on**, 778  
**Brick ornament**, 548  
**Brickmaking royalties, dispute as to**, 727  
**Bricks**: and tiles, ornamental, 338; facing, 436; price of, 584; water-proofing, 251  
**Brickwork**: facing measurement, 112; ornamental, 583; specifications, 368, 403, 442, 477, 515  
**Bridges**: Kew, 634; Leith, 290; Lumley Castle, 848; Niagara (new) 704; Vauxhall, 290  
**Brighton master builders' association**, 561  
**Brind, F. W., the late**, 670  
**Brine v. Palmer**, 148  
**Bristol**: cathedral restoration, 799, 873; electrical ventilation at, 692; master builders' association, 160; mechanical ventilation at, 221; society of architects, 562, 618, 691  
**Britanny, last summer in**, 265  
**British**: architects, royal institute of, 116, 188, 261, 341, 405, 483, 553, 596, 654, 698 (election of council) 690, 692, 812 (presidency) 471, 473, 483 (prize drawings) 82, 85, 117 (royal gold medal) 188, 250, 291, 324, 876; artists, society of, 441; association, waterworks engineers', 654, 763; Isles, escarpments of, 657; museum, Oriental room at, 908  
**Buddhist remains in India**, 523  
**Buider**: and architect, squabble between, 512; and building owner, dispute between, 182; and house agent, 325; serious charge against a, 871  
**Builders**: and sanitary fittings, 55; and Workmen's Compensation Act, 88, 439, 729; clerks' benevolent institution, 261 (dinner) 485; duties and responsibilities, 498; master, associations (Bath) 198 (Brighton) 561 (Bristol) 160 (Coventry) 618 (Crewe) 691 (Dublin) 90 (Newcastle) 618 (National) 149 (Nottingham) 146, 198 (Portsmouth) 229; price-book, Laxton's, 302; useful items for, 398, 410  
**Building**: Act, London (amendment bill) 585 (amendments to) 152 (boundary walls and) 871 (Cripplegate fire and) 149 (London School Board and) 325 (old churches and) 148 (problem) 220 (party walls and footings and) 182, 188; contracts, L.C.C. conditions of, 183; dangers,

623; hurry in, 695; irresponsible, 659; lease, commission on, 363; London and riverside, foundations for, 735, 739, 772; 808; materials, tests of Canadian, 364; negligence in, 767; News designing club, 86, 197, 396, 517, 700, 810; nomenclature, 115; owner and builder, dispute between, 181; trades (association, Manchester and Salford) 470 (exchange, Newcastle-on-Tyne) 363, 836 (directory) 811 (exhibition, Agricultural hall) 147 (do., Manchester) 908 (federation, Bury) 706 (do., Scottish) 618; v. architecture, 399  
**Buildings**: domestic, fireproof construction of, 120, 155; finish of, 81; foundations for London and riverside, 735, 739; height of, in United States, 649; historical, preservation of on the Continent, 439; new sites and, 151; public, composition in regard to, 82; top-loaded, 260; town, construction of, 556  
**Bungalow furniture, club designs**, 810  
**Bungalows, club designs**, 700  
**Burial authorities and purchases of land**, 907  
**Burne-Jones, Sir E., the late**, 883  
**Burning**: lead, 326; of Metropolitan Tabernacle, 586, 726  
**Bury building trades federation**, 706  
**Business premises**: Boscombe, 377; Cleveland, O., 813; Hull (Reckitts') 127; Leeds (assurance) 126; Liverpool (insurance) 229; Reading, 489; Regent-st., W., 9; Windsor, 743  
**By-laws, building**: Blackpool, 148; Ipswich, case under, 220

**CALCULATION**: for floor loads, 59; in hydraulic engineering, 847  
**Calcutta sewage outfall**, 78  
**Calderon, P. H., R.A., the late**, 633  
**California university competition**, 219  
**Cambered niches**, 726  
**Campanili, mediæval, of Rome**, 261  
**Canadian building materials, tests of**, 364  
**Canterbury, St. Martin's church**, 847  
**Cantilever trusses, foundations on**, 90  
**Carburetted water-gas, complaints as to**, 657  
**Cardiff**: architects' reunion at, 269; castle, 183; town hall competition, 8, 112, 181  
**Carpenters**: and joiners, amalgamated society of, 558; Co. lectures, 183  
**Carshton fever hospital competition**, 58, 228, 875, 884  
**Carving, stone, in New York**, 870  
**Case of jurisdiction in land surveying**, 770  
**Casino, villa Pamphili-Doria, Rome**, 527  
**Cast iron**: effect of sea-water on, 4; strength of, 8, 59; tensile changes in, 439  
**Castles**: Bolsover, 527, 779; Cardiff, 183; Chester, 183; Windsor (Clarence meml.) 728  
**Cates, Arthur, retirement of**, 907  
**Cathedral series, Bell's**: Exeter, 124; Lichfield, 302; Norwich, 434; Peterborough, 434; Winchester, 302  
**Cathedrals**: Bristol, 799, 873; Canterbury, 705; Chichester, 764; Cronstadt, 58; Downpatrick, 231; Edinburgh (St. Mary) 523 (book of) 667, 743; Exeter, 341; Glasgow, 252; Hereford, 633; Lincoln, 559 (Ruskin on) 835; Lisieux, 635; Norwich, 434; Perth (St. Ninian) 582; Peterborough, 342, 494, 777, 884; St. Alban's (screen) 834; Salisbury, 304; Siena, 305; Southwark (St. Saviour) 873, 885; Truro, 762; Winchester (organ) 161 (screen) 850  
**Cave, prehistoric, at Oban**, 657  
**Cement**: admixtures, 299; industry, Portland, rise and development of, 667; testing, 906; tests, 220  
**Cemeteries**: Leicester, 343; Nottingham, 7  
**Certificate, architect's, finality of**, 513  
**Changes and extras**, 515

Chapels: Armley, Leeds (Meth. New Conn.) 436; Barry (Wesln.) 180; Bury, Lancs (Bapt.) 503 (Congl.) 546; Chester (Prim. Meth.) 598; Horfield, Bristol (Wesln.) 91; Inverness (Infirmary) 814; King's Heath (Wesln.) 125; Metropolitan Tabernacle, burning of, 586, 726; Mill Hill (school) 851; Newcastle-on-Tyne (Prim. Meth.) 57; Northampton (Bapt.) 762; Sedburgh (school) 127; South Kirkby (Wesln.) 218; Waverley-park, Nunhead (Meth. New Conn.) 199; Weston-super-Mare (Wesln.) 161; Windsor (St. George) 9; Woodbridge (Quay) 654  
Chapter in the history of pottery, 553  
Charges, professional, revised schedule of, 812, 839  
Charterhouse-square, 300  
Cheap paints and pigments, 509, 733  
Chester castle, improvements at, 183  
Chimney stack, size of, 512  
Church: architecture (English, progress of art in) 124 (Scottish) 372; towers of Somersetshire, 221  
Churches: Aberdeen (Free) 510; Armley (Free Meth.) 343; Bangor, Co. Down (Presbtn.) 814; Birmingham (St. Chad) 271; Bourne (Abbey) 270; Bournemouth (St. Stephen) 819; Bradford (parish) 508; Bridgeton, Glasgow (Episc.) 849; Brighton (Bible Christian) 776; Bruton, 9; Burton Lazars (tomb) 887; Bury, Lancs (N. Meth. Free) 670; Canterbury (St. Martin) 847; Cardiff (monastery) 872 (St. Peter R.C.) 634; Chart Sutton, 125; Copenhagen (English) 585; Craigmillar-park, Edinburgh (Free) 776; Crewe (Xc.) 598; Derby (H. Trinity) 342, 547; district surveyors' fees for, 398; Dundee (St. Patrick) 707; Exmouth (All SS.) 229; Felling (SS. John Baptist and Patrick) 271; Flockburgh, 127; Glasgow (St. Patrick, R.C.) 56; Gorbals (Free) 56; Gunnersbury (St. James) 270; Halberstadt (Our Lady) 161; Handforth (St. Chad) 804; Hove (All SS.) 9; Hull (Congl.) 705; Ilford (R.C.) 779; King's Cliffe (All Saints) 582; King's Heath (Bapt.) 505; Königsplutter (SS. Peter and Paul) 161; Liverpool (St. George) 342; Macclesfield (St. Michael) 508; Maidenhead (St. Peter) 582; Manafon (St. Michael) 582; Mellor (St. Mary) 57; Moberley, 60; Moseley, 229; Newbold (monument) 887; Newcastle, Co. Down (St. John) 231; Newcastle-on-Tyne (Presbtn.) 57, 77; Notingham (St. Augustine R.C.) 671; old, and the Building Act, 148; Old Kilpatrick, 546; Oldswinford (St. Mary) 777; Old Whittington, 280; Paisley (Abbey) 126; Sledmere (St. Mary) 885; small suburban, club designs, 396; Southend-on-Sea (St. Alban) 7; Southport (Emmanuel) 582; Southwark (St. Saviour) 873, 885; Springfield, Glasgow (U.P.) 885; Stranraer (U.P.) 435; Wellington, Salop (All SS.) 582; Weston-super-Mare (district) 180; Wombwell (St. Mary) 634; Woodvale, Belfast (Presbtn.) 850  
City: and Guilds institute, 728; fire protection in the, 811; Guildhall, guide to, 702; hall, Philadelphia, 590; surveyor of Bath (action by) 584 (libel action against) 292  
Civil: and mechanical engineers' society, 562; engineers, institution of, 618, 634  
Cleaning headstone, 471  
Clearing drains, 522  
Clerk: builders', benevolent institution, 261, 465; of works (and Workmen's Compensation Act) 835 (association dinner) 228  
Clips, wrought-steel pipe, 560  
Clothing ideas, 551  
Club, BUILDING NEWS designing, 86, 157, 396, 517, 700, 810  
Clubhouses: Birkenhead (Libl.) 125; Cleckheaton (Libl.) 190; Nuneaton (Conserv.) 779; St. Anne's-on-Sea (golf) 342; Surbiton, 547  
Coat of paint, a, 196, 224  
Cochrane, Chas., the late, 704  
Collapse: of basement vault, Marylebone, 810; of roof, 525 (at Abbey-mansions, Westminster) 621, 623, 668, 702, 736, 763, 887  
Colleges: Bromley, Kent, 127; Glasgow and West of Scotland (technical) 728; Manchester (Owen's) 470 (Christie library) 705  
Columns, fixing, 773  
Column, tests, 387  
Combinations, steel and concrete, 629  
Commission: extra, 512; house agent's, law of, 47; a building lease, 363  
Communication, direct, between streets, 549  
Comparative strength of riveted and bolted joints, 523  
Compensation Act, Workmen's: and employers' liability, 477; architects' assistants and clerks of works and, 835; builders and, 88, 439; Willis's, 434  
Competitions: 655; baths (Battersea) 563 (Romford) 704 (Walthamston) 8, 59, 91, 111 (Wimbledon) 851 (Winchester) 671, 813; board schools (Carlisle) 91 (Colne) 91 (Weston-super-Mare) 671; BUILDING NEWS designing club, 86, 197, 396, 517, 700, 810; cathedral (Cronstadt) 58; cemeteries (Leicester) 343 (Nottingham) 7; chapels (Horfield, Wesln.) 91 (South Kirkby, Wesln.) 218 (Weston-super-Mare, Wesln.) 161; churches (Aberdeen, Free) 510 (Armley, Free Meth.) 343 (Derby, H. Trinity) 547 (Southend-on-Sea, St. Alban) 7; clubhouse (Surbiton)

547; cottage hospitals (Bishop Auckland) 270 (Skipton) 58; decorating mayor's rooms (Leeds) 778; drinking fountain (Ballycastle) 742; drawings (Soane and Institute) 82, 117; electric lighting (Ludlow) 682, 671; exhibition buildings (Glasgow) 671, 778; fire brigade station (Bootle) 58, 230, 671; free libraries (Port Elizabeth, S.A.) 582 (Putney) 450 (Wolverhampton) 230; hospital (Boscombe) 450 (Carshalton, fever) 58, 228, 875, 884 (Ystrad, fever) 305; infirmary (Dorking, workhouse) 305; laying-out park (Tipson) 884; lunatic asylums (Holly Moor, Birmingham) 7, 343, 510, 547 (West Bangour) 126; Masonic institution (Bushey) 343, 671; monument (soldiers and sailors', New Jersey) 7; morality and economy of, 592; municipal buildings (Godalming) 671 (Plymouth) 851; police station (Berwick) 704; poster designs, 7, 218, 343; public offices (Altrincham) 434; school of art (Harrogate) 270; schools (Bushey, Masonic) 126, 343 (East Finchley, Sunday) 58, 111, 267 (Wadebridge, meml.) 450 (Westbury-on-Tyne, National) 91; sewerage (Morecambe) 91; sundials, 813; technical institutes (Gillingham) 126 (Trowbridge) 778, 851; technical school (Harrogate) 547; town halls (Cardiff) 8, 112, 181 (Dukinfield) 547, 619 (Oundle) 742 (Singapore) 147 (Southend) 635 (Taunton) 230, 671, 742, 815; university (California) 219; War office, 692; water supply (Crich and South Wingfield) 230, 742; workhouses (Kirkham, Fylde) 91, 511, 548, 619 (Hastings) 510 (Wolverhampton) 704, 742, 778  
Complete perspective course, 702  
Composition: hygeian rock, 436; in architectural studies, 112; in regard to public buildings, 82  
Concrete: and steel combination, 629; construction of arches in, 157; floor tests, 157; slabs, 736  
Conditions of building contracts, L.C.C., 183  
Connah's Quay, drainage litigation at, 871  
Conservatories, Edinburgh botanic gardens, 435  
Constructional: steel, 446; work, wrought iron and steel in, 53, 334, 411, 482, 518  
Construction: fireproof, of domestic buildings, 120, 155; of arches in concrete, 157; of town buildings, 556; steel, American and English, 735  
Contractor's stoneyard, is it a nuisance? 620  
Contracts: L.C.C. building, conditions of, 183; payments under, 220  
Convaescent: home, club designs, 517; hospital, Carshalton, 58, 228  
Cope, G. H., the late, 776  
Copying processes for reproducing plans, 414, 481  
Copyright, artistic, for architects, 484, 597  
Cornell travelling studentship, 729  
Cost of pile driving with steam hammer, 846  
Cottage: Anne Hathaway's, restoration of, 473; homes (Mill Hill, Linendrapers') 635 (Middlewood, Rochdale) 779; hospitals (Acton) 634 (Bishop Auckland) 270 (Skipton) 58  
Cottages, Colvin estate, Waltham Abbey, 887  
Cotton, silicate, 398  
County: council buildings, Durham, 776; hall, Wakefield, 270  
Course: complete perspective, 702; damp, 251  
Covenants, restrictive, not binding on vendors, 907  
Coventry master builders' association, 618  
Cowny valley reservoir, 362  
Craft independence, 331  
Crafts, architectural, progress of, 1  
Crane scaffolding, Edinburgh, 655  
Crewe: master builders' assoc., 691; railway improvements at, 57  
Crich and South Wingfield water supplies, 230, 742  
Cripplegate fire: 179; and the Building Act, 149  
Cripples' home, Bournemouth, 851  
Cross, W. and T., Warrington, in re, 656  
Curiosity, an architectural, 515  
Curtain, a water, 729  
Custom, a question of, 472  
DAMAGES, liquidated, 251  
Damp-course, 251  
Dangers, building, 623  
Dangerous floors, 301  
Davies, Walter, the late: of Lee, S.E., 562; of Tenby, 510  
Deal, red and yellow, 147, 181  
Decoration: mantel, 525; of Doge's palace, Venice, 79; of furniture and wooden ware, 846  
Decorative: arts, reference books on, 89, 118; use of mosaic in architecture, 628; work, Greek and Pompeian, 225  
Defective soil pipes, 512  
Delay, penalties for, 251  
Dellwik water-gas, 729  
Delphi, excavations at, 293  
Democracy, industrial, 52  
Depreciation of adjoining property, board schools and, 871  
Derbyshire villages, joint water supply, 148  
Designing club, BUILDING NEWS, 86, 197, 396, 517, 700, 810  
Design: basis of, 374; of theatres, 260  
Designs: BUILDING NEWS designing club, 86, 197, 396, 517, 700, 810; Carshalton fever hospital, 575, 884; National, 161; posters, 7, 218; Soane and R.I.B.A., 82, 117  
Detail, specifications in, 268  
Development of: Portland cement industry, 667; the tomb in Egypt, 835  
Devon architectural society, 691  
Dickeson v. Heppburn and Gale, arbitration, 148  
Difficulties of a land agent's practice, 555  
Dilapidations, ecclesiastical, 725  
Dinners: architectural assoc., 769; builders' clerks' benevolent, 485; clerks of works assoc., 228; district surveyors' assoc., 846; H.M. Office of Works, 183; society of architects, 591; surveyors' institution, 194; Young and Marten's, 221  
Diocesan surveyor, an advertising, 325  
Direct communication between streets, 549  
Directory, building trades, 811  
Discovering talent in art, 295  
Distemper, sanitary washable, 253  
District surveyors: association dinner, 846; fees (for churches) 398 (for Jubilee stands) 47  
Dobson, W. C. T., R.A., the late, 160  
Docks: Liverpool (extensions) 511; Swan-sea, 436  
Doge's palace, Venice, decoration of, 79  
Domestic: architecture in Eastern States of America, 554; buildings, fireproof construction of, 120, 155  
Douglas, Isle of Man, sewerage of, 78  
Douglass, Sir J. N., the late, 883  
Drainage, house: 324, 295; specification for, 331, 368  
Drain: main, or sewer, 620; pipes, 906 (jointing) 324  
Drains, clearing, 522  
Drama, housing of the, 189  
Drawing: heraldic, 405; ink for, 870  
Drawings: royal academy, 199; Soane and R.I.B.A., 82, 117  
Drew-Bear v. St. Pancras guardians, 77, 110, 147, 251  
Drinking fountain, Ballycastle, 742  
Driver, H. Collier, the late, 562  
Driving, pile, cost of, 846  
Dry and wet rot, 436  
Dublin: master builders' association, 90; St. Patrick's well, 799  
Dudley gallery exhibition, 223, 839  
Durham: archaeological society, 886; county council buildings, 776  
Durolme not watertight, 437  
Duties and responsibilities, builders', 438  
Dwellings: artisans' (Brighton) 271; labourers' (Birmingham) 776 (Manchester) 180 (Perth) 849; working men's (bill) 835 (Leeds) 849  
EARL'S Court wheel, 842  
Early sculptures of Argyllshire, 113  
Eastern States of America, domestic architecture in, 554  
Easflake, C. L., retirement of, 549  
Eccles, conversion of privies into w.c.'s, 110  
Ecclesiastical dilapidations, 728  
Ecclesiological society, St. Paul's, 146  
Economy and morality of competitions, 592  
Edinburgh: architectural association, 146, 229, 397, 470, 547, 691, 813; architectural society, 198, 269, 691, 813; decoration of children's hospital mortuary, 814; improvements (Greyfriars churchyard) 835 (North Bridge-street) 473; public health professorship, 873; staging fatal accident, 441, 514, 655, 871; technical school, 364  
Edmonston, Jas., the late, 340, 397  
Education, technical, total output on, 221  
Effect of sea-water on cast iron, 4  
Egyptian tomb: development of, 835; royal, 525  
Egypt: development of the tomb in, 835; the birthplace of architecture, 261  
Eighteenth century, English art in, 883  
Electrical ventilation at Bristol, 692  
Electric: current supply at Glasgow, 657; lighting (as applied to architecture) 665 (for the house) 303 (notes for architects) 122, 194, 226, 298, 405, 486, 520, 630, 662, 842, 880; v. hydraulic elevators, 122; tramway, Alexandra palace, 511  
Electricity: and gas, comparative cost of, 473; industrial, 702; supply of London, 519  
Elevators, hydraulic v. electric, 122  
Employers' liability and workmen's compensation, 477  
Engineering: hydraulic, calculation in, 847; sanitary, 633  
Engineers: civil and mechanical, society, 562; municipal (handbook) 701 (qualification) 690; society of, 341, 842; water-works, British association of, 654, 763; year-book, 268  
English: and American steel construction, 735; art (in 18th century) 883 (in illuminated manuscripts) 473; church architecture, progress of art in, 124  
Ephesus, excavations at, 596  
Epileptics' home, Chalfont St. Peter's, 271, 668  
Examination, surveyors' institution, 155  
Examples of Greek and Pompeian decorative work, 225  
Excavations at Delphi, 293  
Excavators, specifications for, 295, 331  
Exchange, building trades, Newcastle-on-Tyne, 363, 836  
Exeter diocesan architectural socy., 341  
Exhibitions: ancient Southampton, 586; art metalwork, Aquarium, 741, 771 (awards) 811; building trades (Islington) 147 (Manchester) 908; Dudley gallery, 223, 839; Fine Art society's, 692; French art at City, Guildhall, 803; Glasgow (competition) 671, 778 (water colour) 621; health (New York) 79; institute water-colour painters, 367; New gallery, 589;

royal academy (architecture at) 587, 623 (Millais' pictures) 2 (pictures at) 587, 624, 639, 695; royal Scottish academy (architecture at) 333; society of British artists, 441; technical school, L.C.C., 549; Vienna art, 399  
Expanded metal for fireproof construction, 264  
Experiment: at Salford in sewage purification, 225; on strength of timber, 293  
Explosive, tonite as an, 113  
External wall, 775  
Extra commission, 512  
Extras: and penalties, 512; changes and, 515; no, 834  
FACING: bricks, 436; measurement, brickwork, 112  
Factory, Sheffield, 549  
Fair wages, urban authorities and, 586  
Farm buildings, Copped hall, Epping, 415  
Fatures, neglected, 223  
Federations: building trades (Bury, Lancs) 706 (Scottish) 618; master painters' (North of England) 229  
Fees, district surveyors': for churches, 398; for Jubilee stands, 47  
Fever hospitals: Brook, Shooter's-hill (cost of) 301, 396, 621, 836; Carshalton, 58, 228, 875, 884; Colinton Mans, 547; Sealand (Chester) 80; South Western, 470; Ystrad, 305  
Finality of architect's certificate, 513  
Fine: art society's exhibition, 692; arts, sanitation and the, 559  
Finish of buildings, the, 81  
Fire: and panic, lessons from, 555; brigade station (Bootle) 58, 230, 671; Cripplegate, 79; prevention (and Building Act) 149 (committee) 657; protection in the City, 811  
Fire float for the Thames, 439  
Firegrade, 220  
Fireplaces, Bolsover castle, 527, 779  
Fireproofing construction: expanded metal and, 264; of domestic buildings, 120, 156  
Fittings: builders and sanitary, 55; plumbing, 548, stable, 198  
Fixing: columns, 775; stone, 906  
Flare-burnt lime, 906  
Flats, Paris, Maison de Rapport, 707  
Floor: cloth, wood pulp in, 586; loads, calculation for, 59; tests, tile and concrete, 157  
Floors: dangerous, 301; solid, 8  
Font cover, Cockington, 489  
Football field, Sunderland, 885  
Footbridge, liability for repair of, 620  
Footings and party walls under Building Act, 182, 188  
Footpath society, National, 293  
Foot pavements in Glasgow, 253  
Forecours, temporary structures in, 584  
Foundations: for London and riverside buildings, 735, 739, 772, 806; on cantilever trusses, 96  
Fountain, Market Drayton, 888  
Free libraries: Balham, 527; club designs, 197; Hammersmith, 60; Fort Elizabeth, 582; Putney, 450; Wolverhampton, 415, 451  
French art at the Guildhall, 803  
Frenet, Jas., New Orleans, the late, 303  
Fronts, replacing, 524  
Fuels, working value of, 524  
Fulham gasworks, 842  
Furniture: and woodenware, decoration of, 846; bungalow, club designs, 810; old, examples of, 90, 161  
GALLERIES: Dudley, 223, 839; Guildhall, French art at, 803; National (educational uses of) 79 (isolation of) 304, 472 (Italian painters at) 252 (new pictures) 149 (report) 835; Manchester art, 57; National portrait, 764; new, 589; Scottish National portrait, 622, 738  
Galvanised iron, painting, 398  
Gas: acetylene, 336; and electricity, comparative cost of, 473; offices, Exeter, 885; pipes, water in, 762; refuse and river pollution, 620; sewer, 302; water (carburetted) 657 (Dellwik) 729  
Gasworks: Fulham, 842; machinery, 809  
Gates at Newnham Paddox, 815  
Gauged work, 512  
Geological museum, removal of the, 621  
Gigantic wheel, Earl's Court, 842  
Gilbert, Sir J. T., Dublin, the late, 741  
Girdler, load on, 251, 291  
Glasgow: and West of Scotland technical college, 728; architectural association, 90, 160, 303, 691, 850; cathedral, 252 (book of) 667, 743; electric current supply, 657; exhibition buildings, 671, 778; foot pavements in, 253; master wrights' association, 654; property sales in, 293; water-colour exhibition, 621  
Gold: Coast, surveyors on the, 690; medallist, royal, 188, 250, 291, 324, 876  
Government public offices, 362, 403, 437, 472, 513, 692  
Grammar school, Bridlington, 849  
Granite v. wood paving, 326  
Grate, fire, 220  
Great Central railway, 546  
Greek and Pompeian decorative work, examples of, 225  
Green: B. J., Wolverhampton, in re, 584; Chas., the late, 633  
Greenwich-park, additions to, 79  
Grievances, professional, 51  
Grimwood, G. H., the late, 269  
Ground plan of London, 149  
Guardian assurance co., 364  
Guide to City Guildhall, 702

Guildhall, City: gallery, French art at, 803; guide to, 702; museum, additions to, 112

**HALLS:** Aberdeen (Trades, decoration of) 508; Bolton (Central Westn.) 670; Cockfield, Yoxford, 435; Guernsey (States Assembly) 489; Ipswich (Central Westn.) 885 (Settlement-buildings) 180; Manchester (Whitworth) 470; Philadelphia (city) 560; Randolph, Cambridge, Mass., 743; Wakefield (county) 270; Wardley, 158; Westminster (condition of) 290

Hall's sanitary washable distemper, 253  
Hammer, steam, cost of pile driving with, 846  
Hampstead-heath and the Wells estate, 873  
Hampton Court, 192  
Handbook, municipal engineer's, 701  
Harbours: Hastings, 701; Peterhead, 342  
Hard case of "no extras," 834  
Harrogate waterworks arbitration, 182, 252  
Hat, architect's, and the unseen wire, 437  
Hathaway's cottage, restoration of, 473  
Hayter, Harrison, the late, 670  
Headstones, cleaning, 471  
Health exhibition, New York, 79  
Heating: steam, systems of, 523; swimming baths, 701  
Height of buildings in United States, 549  
Heraldic drawing, 405  
Higher grade schools: Bristol, 705; Scarborough, 707  
High school, Shrewsbury (girls') 60  
Historical drawings, preservation of on the Continent, 439  
History: of architecture for the student, 124; of pottery, a chapter in, 558  
Hoffman v. Halley, architects' dispute, 221  
Holborn to Strand, proposed street, 878  
Holiday home, Clacton, 707  
Hollins, M. D., the late, 198  
Hollow-wall ties, 436  
Home art and industries assocn., 325  
Homes: convalescent (club designs), 517; cottage (Middlewood) 779 (Mill Hill) 635; cripples' (Bournemouth) 851; deaf and dumb children (Leeds) 435; epileptics' (Chalfont) 271, 668; holiday (Clacton) 707  
Hornsea, im. movements at, 849  
Hospitals: Acton (cottage) 634; Bishop Auckland (cottage) 270; Boscombe, 450; Brook, Shooter's-hill (fever, cost of) 301, 396, 621, 836; Carshalton (convalescent) 58, 228, 875, 884; Colinton Mains (fever) 547; Dunedin, N.Z. (operating theatre) 6; Gray's Inn-road (Royal Free) 415; Leamington (Warneford) 670; Sealand, Chester (fever) 180; Skipton (cottage) 58: South-Western, cost of, 470; Ystrad (fever) 305

Hotels: Barton-on-Sea (Court) 599, 845; Birmingham (Hen and Chickens) 634; Braemar (Five Arms) 56; Bury-st., W. (Marlborough) 305; Edinburgh (North British railway) 180; Kensington (Royal Palace) 270; Newington Butts (Elephant and Castle) 91; Newquay (Headland) 363; Rhos (Abbey) 527; Stuttgardt (Marquardt) 199  
Hot-water system, 726  
House: agent and builder, 325; agent's commission, law of, 47; decorators and painters, society of, 303, 341; drainage, 324; electric lighting for the, 303; sanitary, medical health officer and his, 727  
Houses: Broadway, 671; Buckingham palace-mansions, 127; Caen (de la Bourse) 10; Coggeshall, 489; Forest lodge, Tulse-hill, 743; Ghent, 9; Glenroy, Finchley, 743; Goodrich Court, 599; Gosfield-st., W., 231; Grange-over-Sands, 271; Hawick, 127; Medmenham, 887; Newdigate-place, 305; of Parliament, mosaics at, 252; Red, Harpenden, 851; Rum, N.B., 57; Sandhoe, 634; Shackleford, 779; Stonehaven, 304; Summerdale, Epsom, 91; Sutton, Surrey, 671; Thorpe Mandeville, 779; Wood Norton, King's Norton, 489  
Housing of the: drama, 189; working classes, 325, 621  
Howe, Robert, the late, 193  
Hundred summonses against a builder, 77  
Hurry in building, 695  
Hydraulic: engineering, calculation in, 847; v. electric elevators, 122  
Hydropathic, Dunblane, 397  
Hygeian rock building composition, 436

**IDEAS,** clothing, 551  
Illinois, licensing of architects in, 47, 252, 561  
Illuminated manuscripts, English art in, 473  
Illustrations: of Lincoln cathedral, 559; of Scottish church architecture, 372  
Imitation varnishes, 519  
Improvements in Westminster, proposed, 47  
Incandescent: electric lighting, 662; light, new, 693  
Independence, craft, 331  
India, Buddhist remains in, 523  
Indicators, station, 524  
Industrial: democracy, 52; electricity, 702  
Infirmary: Dorking (workhouse) 305; Edinburgh (Royal) 56, 113; Manchester (Royal) 253; Milton, Portsea (workhouse) 342; N. wton Abbot (workhouse) 110; Solihull (workhouse) 849; Warrington (workhouse) 342  
Influence of sea-water on mortar, 90

Inn, Nottingham (Hedgehog) 60  
Insanitary house, medical health officer and his, 727  
Inspectors, sanitary, association, 5, 269, 691  
Institutes: arts and crafts, Camberwell, 6; auctioneers', 47, 397, 706: British architects', royal, 116, 188, 250, 261, 291, 324, 341, 405, 471, 473, 483, 553, 596, 654, 690, 692, 698, 812, 876 (prize drawings) 82, 85, 117; church (Seaford) 849; City and Guilds, 728; Clerkenwell (Northampton) 435; Coniston, 598; iron and steel, 586; Newcastle-under-Lyme, 270; royal archaeological, 799; sanitary, 887; technical (Gillingham) 126  
Institutions: artists' benevolent, 691: builders' clerks' benevolent, 261, 485; civil engineers, 618, 634; painters in water-colours, 367; surveyors', 55, 123, 193, 337, 411, 514, 632, 668, 699 (at Manchester) 514, 554 (dinner) 194 (examination) 155  
Instructions to architects, 115  
Insufficient and unreasonable private streets works, 793  
Insurance: municipal, at Nottingham, 764; of builders' men, 906  
Interior lighting, reflected lights for, 664  
Ireland, architectural association of, 60, 146, 229, 763  
Irresponsible building, 659  
Iron: and steel institute, 586; cast and wrought, strength of, 8, 59 (effect of sea-water on) 4 (tensile changes in) 439 painting galvanised, 398; protection of, 220; staircase, Hayward and Eckstein's, 439; uprights, 302; wrought, and steel in constructional work, 53, 334, 411, 482, 518  
Ironmongers and plumbers' registration, 473  
Ironwork, South Kensington museum, 666, 701, 735, 775, 808  
Is a contractor's stoneyard a nuisance? 620  
Italian pictures at National gallery, 252  
Items, useful, for builders, 338, 410

**JERRY** building in Belfast, 47  
Joinery, oak, paint for, 251  
Joining drain pipes, 324  
Joints, comparative strength of riveted and bolted, 623  
Jones, Sir E. Burne, the late, 883  
Jubilee stands, district surveyor's fees for, 47  
Jurisprudence in land-surveying, case of, 770  
**KEENE**, Chas.: sketches by, 181, 774; work of, 85  
Keeping pace, 803  
Kensington, South: museum (competition of) 183, 230, 437, 599 (improvements at) 799 (ironwork at) 666, 701, 735, 775, 808; science and art buildings, 728, 907  
Kettlewell, W., Leeds, the late, 598  
Kew-green, medallions from, 764, 835  
Kirkham, Fyde, workhouse competition, 91, 511, 548, 619  
Kirk, Professor, the late, 396

**LABOURERS'** dwellings: Birmingham, 776; Manchester, 180; Perth, 849  
Lacey, T. W., Rochester, 292  
Lampert arbitration case, 513  
Lancashire and Yorkshire antiquarian socy., 850  
Land: agent's practice, difficulties of, 555; surveying, case of jurisprudence in, 770; values, taxation of, 3  
Landing-stage extension, Liverpool, 559  
Lands Clauses Consolidation Act, 584  
Last summer in Brittany, 265  
Later Renaissance architecture in England, 597  
Laver, Augustus, the late, 662  
Law: of house agents' commission, 47; of master and servants, Smith's, 847; new streets, 648  
Lawrence, Nathaniel T., the late, 633  
Laws and by-laws, sanitary, 479  
Laxton's builders' price-book, 302  
Lead burning, 326  
Leadwork, plain and decorative, 297  
Lease, building, commission on, 363  
Lectures, Carpenters' Co., 183  
Leeds: and Yorkshire architectural socy., 100, 198; building activity in, 538; lord mayor's rooms, decoration of, 778  
Lees, Joseph, the late, 198  
Legal liability for professional opinion, 267  
Leighton memorial art institute, Camberwell, 6  
Lessons from fire and panic, 555  
Liability: employers', workmen's compensation and, 477; for repair of foot-bridges, 620; legal, for professional opinion, 267  
Libel action against a city surveyor, 292  
Libraries, free: Balham, 527; club designs, 197; Hammersmith, 60; Port Elizabeth, 582; Putney, 450; Wolverhampton, 230, 415, 451  
Libraries: Birmingham (old) 598; of the middle ages, 698; Manchester (Christie) 705  
Licensing of architects in Illinois, 47, 252, 561  
Life and death, a matter of, 726  
Light: easement of, 220; new incandescent, 690; rights to, owners of property and, 444  
Lighting: electric (as applied to architecture) 665 (notes for architects) 122, 194, 226, 298, 406, 486, 520, 630, 662, 842, 890; interior, reflected lights for, 664

Lights: pavement, 198; reflected, for interior lighting, 664  
Lime, flare-burnt, 906  
Lincoln cathedral: by P. de Wint, 559; Ruskin on, 835  
Lintel and architrave, stone, 778  
Liquidated damages, 251  
Liquid paint for stove, 764  
Liverpool: architectural society, 562, 706; city surveyorship, 252; landing-stage surveyorship, 559  
Load: on girder, 251, 291; safe, 8  
Loads, floor, calculation for, 59  
Lock, proposed, at Wandsworth, 90  
Lodge, Derby park, Bootle, 79  
London: board schools, improvement of, 399, 621; Building Act (amendment bill) 585 (amendments to) 152 (boundary walls and) 871 (Cripplegate fire and) 149 (London School Board and) 325 (old churches and) 148 (party walls and footings under) 182, 188 (problem) 220; buildings, foundations for, 735, 739, 772, 806; County Council, 183, 470, 514 (as investors in ground-rents) 363 (conditions of building contracts) 183 (power to reject plans) 798 (works department) 149; electricity supply of, 519; ground plan of, 149; School Board and Building Acts, 325; water commission, 148, 180, 324, 399, 438, 727, 763, 834  
Long, S. J., the late, 340  
Lowenstam, Leopold, the late, 776  
Lubricant for plaster moulds, 149  
Lunatic asylums: Coxledge, Newcastle, 304; Hellingly, East Sussex, 705; Holly Moor, Birmingham, 7, 343, 510, 547; West Bangour, 126

**M'CAMMOND**, Sir W., the late, 303  
Machinery: gasworks, 809; woodworking, 870  
Magazine, powder, 656  
Maidstone, typhoid fever at, 180  
Main drain or sewer, 620  
Manchester: biological sewage treatment, 438; building trades (association) 470 (exhibition) 903; contractor, fraud by, 620; corporation v. Perkins, Graham, and Co., 513, 584, 656; royal infirmary, 253; sewage disposal difficulties, 513, 654, 727; society of architects, 303; surveyors' institution at, 514, 554; Thirlmere water supply, 621  
Mansions: Albert-gate (Park) 743; Westminster (Abbey) 563 (do., collapse of) 621, 623, 668, 702, 736, 763, 887 (Army and Navy) 887  
Manslaughter, architect acquitted of, 733, 887  
Mantel decoration, 525  
Manual training woodwork, 847  
Manufacturing refuse, sewerage provision for, 656  
Manuscripts, illuminated, English art in, 473  
Manslaughter, architect acquitted of, 763, 887  
Marl, C. J., the late, 193  
Marks, H. Stacey, R.A., the late, 56  
Marylebone, collapse of vault in, 810  
Masonic schools, Bushey, 126, 343  
Masonry specifications, 697, 731, 767, 804, 840, 875  
Master: and servant, Smith's law of, 847; builders' associations (Bath) 198 (Brighton) 561 (Bristol) 160 (Coventry) 618 (Crewe) 691 (Dublin) 90 (National) 149 (Newcastle) 618 (Nottingham) 146, 198 (Portsmouth) 229  
Matter of life and death, 726  
Measurement, brickwork facing, 112  
Measurements, square, 123  
Mechanical ventilation at Bristol, 221  
Mechanism, stage, 556  
Medallist, royal gold, 188, 250, 291, 324, 876  
Medallions from Kew-green, 764, 835  
Medical health officer and his insanitary house, 727  
Medieval campanili of Rome, 261  
Memorials: Whitby (Caedmon) 148; Windsor castle (Clarence) 728  
Metal: expanded, and fireproof construction, 264; work (architectural) 811 (art, exhibition, Aquarium) 741, 771 (do., awards) 811  
Metropolis Management Act amendment bill, 906  
Metropolitan: asylums board and Brook hospital, 301, 396, 621, 836; Tabernacle, burning of, 586, 726; water commission, 146, 180, 324, 399, 438, 727, 763, 834  
Micklethwaite, J. T., and Westminster abbey, 325  
Middle ages, libraries of, 698  
Mills' works at the academy, 2  
Miller v. London County Council, 325  
Milo, excavations at, 657  
Mission: buildings, Belfast, 305; halls, Central Wesleyan (Bolton) 670 (Ipswich) 885  
Model specifications, 250, 295, 331, 368, 403, 442, 477, 515, 551, 599, 626, 660, 697, 731, 767, 804, 840, 875  
Modern tenement, the, 183  
Moffat, sewage purification at, 362  
Moment, bending, 395  
Monumental brasses in Westminster abbey, 692  
Monuments: Burton Lazars, 887; Cardiff monastery churches, 872; Chichester cathedral (Dunford) 764; Newbold, 887; New Jersey (soldiers and sailors) 7  
Morality and economy of competitions, 592  
Moreau, Gustave, the late, 562  
Morecambe: novel tower for, 849; sewer- ing of, 91, 727

Morris, William, lifework of, 692  
Mosaic, decorative use of, 628  
Mortar, influence of sea-water on 90  
Morton, Francis, and Co., in re, 437, 472, 620, 834  
Moulds, plaster, lubricant for, 149  
Muddled as usual, 690  
Municipal: and sanitary engineers' handbook, 701; buildings, Godalming, 671; engineer's qualification, 690; insurance at Nottingham, 764; workshops, Battersea, 125  
Museums: British (Oriental room) 908; Forest-hill (Horniman) 435; Geological, removal of, 621; Guildhall, E.C. (additions to) 112; royal architectural, 845; South Kensington (completion of) 183, 230, 437, 599 (improvements at) 799 (iron-work at) 666, 701, 735, 775, 808 (rebuilding of) 633, 907  
Music halls: Holborn, 9; Edgware-road (Metropolitan) 271; Islington (Collins's) 47  
**NASH** v. Davis, libel action, 292  
National: associations (master builders') 149 (slaters) 708; foothpath society, 293; gallery (educational uses) 79 (isolation of) 304, 472 (Italian pictures at) 252 (new pictures) 149 (report) 835; portrait gallery, 764  
Natural art, 731  
Neglected features, 223  
Neglecting to abate nuisance, 438  
Negligence in building, 767  
New: book on old furniture, 90; Brighton tower, 126; gallery pictures, 589; incandescent light, 690; Scotland-yard, Sir W. Harcourt's strictures on, 473, 526; sites and buildings, 151; street, Holborn to Strand, proposed, 878; streets, proposed amendment of law as to, 48; York (health exhibition) 79 (municipal art society) 873 (stone carving) 870  
Newcastle-on-Tyne: building trades exchange, 363, 836; master builders' association, 618  
Newmarket building estate, a, 693  
Niches, cambered, 726  
"No extras," a hard case, 834  
Nomenclature, building, 115  
Norton-sub-Hamdon, 633  
Notes: electric lighting, for architects, 122, 194, 226, 298, 406, 486, 520, 630, 662, 842, 880; parliamentary, 230, 290, 304, 399, 472, 513, 585, 599, 728, 763, 830, 906  
Notices, party wall, 325  
Nottingham: master builders' association, 146, 198; municipal insurance at, 764; Trent Bridge embankment, 814  
Nuisance: is a contractor's stoneyard a? 620; neglecting to abate, 438

**OAK** joinery, paint for, 251  
Oban, prehistoric cave at, 657  
Obituary: Allan, A., 303; Barwell, J., 450; Bedello, C. King, 5; Bland, J., Birmingham, 704; Brind, F. W., 670; Burne-Jones, Sir E., 883; Calderon, P. H., R.A., 633; Cochrane, C., 704; Cope, G. H., 776; Davies, Walter (of Lee) 562 (of Tenby) 510; Dobson, W. C. T., R.A., 160; Douglass, Sir J. N., 883; Driver, R. Collier, 562; Edmeston, J., 340, 397; Freret, Jas., 303; Gilbert, Sir J. T., 741; Green, Chas., 633; Grimwood, G. H., Sudbury, 269; Hayter, Harrison, 670; Hollins, M. D., 198; Howe, Robert, 198; Kettlewell, W., Leeds, 598; Kirk, Prof., 396; Laver, A., 562; Lawrence, N. T., 633; Lees, Jos., 195; Long, S. J., 340; Lowenstam, 276; M'Cammond, Sir W., 303; Marc, C. J., 193; Marks, H. Stacey, R.A., 66; Marsland, Mrs. Ellis, 303; Moreau, Gustave, 562; Morris, Wm., 692; O'Byrne, Jas., 160; Purnell, E. J., Jun., 303; Rawlinson, Sir Robt., 775; Skelton, T. A., 450; Starforth, J., 741; Stent, S., 775; Thompson, J., Peterborough, 525; Till, W. S., Birmingham, 269, 309; Watson, W. M., 562; White, F. Meadows, 742; Witherington, W. Seckham, 598; Yriarte, C., 625  
O'Byrne, Jas., Liverpool, the late, 160  
Offices: Altrincham (public) 434; Birmingham (assurance) 705; Eastleigh (U.D.C.) 599; Exeter (gas) 885; Gatestead (school board) 56; Government public, 362, 403, 437, 472, 513, 692; Hull (Reokitt's) 127  
Old: churches and the Building Act, 148; furniture, new book on, 90  
Operating theatre, Dunedin, N.Z., 6  
Ornamental: bricks and tiles, 338; brick-work, 583  
Ornament: and decorative arts, reference books on, 89, 118; brick, 515  
Owner, adjoining, 583  
Owners of property and rights to light, 444

**PACE**, keeping, 803  
Paint: a coat of, 196, 224; for oak joinery, 251; liquid, for stone, 764; scaling of, 560  
Painters in water-colours institute, 367  
Painting galvanised iron, 398  
Paints and pigments, cheap, 509, 733  
Palaces: Genoa (Durazzo) 9; Hampton Court, 192; Westminster, mosaics at, 252  
Panic and fire, lessons from, 555  
Parallel to Walthamstow, a, 58, 111  
Park, Tipton, 854  
Parliamentary notes, 230, 290, 304, 399, 437, 472, 513, 585, 599, 728, 763, 850, 906  
Parliament-street, 834



Party: structure, 847; wall notice, 325; walls and footings under Building Act, 182, 188

Patented plans, 597

Pavement lights, 198

Pavilion, cricket, Denstone college, 271

Paving, wood v. granite, 326

Payments under contracts, 220

Peabody fund report, 364

Penalties: and extras, 512; for delay, 251

Penrose, F. C.: honours to, 873, 907; portrait of, 403

Perspective course, complete, 702

Pewsey, 78

Philadelphia city hall, dome of, 560

Photography: architectural, 633; for architects, 648

Pictures at royal academy, 587, 624, 659, 695

Piers: Dunoon, 848; Herne Bay, 848; Port Victoria, 342

Pigmnts and paints, cheap, 509, 733

Pile driving with steam hammer, cost of, 846

Pipe-clips, wrought steel, 560

Pipes: drain, 906 (jointing) 324; soil, defective, 512

Pitchpine, supply of, 728

Plain and decorative leadwork, 297

Plans: patented, 597; power to reject, L.C.C.'s, 798

Plaster moulds, lubricant for, 149

Plumbers': apprenticeship deeds, 325; registration, 692, 764 (ironmongers and)

Plumbing fittings, 648

Plymouth: new building by-laws for, 252; public buildings competition, 851

Police station, Berwick, 704

Pollution, river, gas refuse and, 620

Polytechnic institute, Clerkenwell (Northampton) 433

Pompeian and Greek decorative work, examples of, 225

Porch, Upper Langford, 563

Portland cement industry, rise and development of, 667

Portrait galleries: National, 764; Scottish National, 622, 728

Portraits, Lionel Cust on, 483

Portsmouth master builders' association, 229

Position, present, of sewage purification problem, 847

Posters, designs for, 7, 218, 343

Pottery, chapter in the history of, 558

Powder magazine, 656

Power to reject plans, L.C.C.'s, 798

Practical sanitary details, 370

Present position of sewage purification problem, 847

Preservation of historical buildings on the Continent, 439

Presidency R.I.B.A., 471, 473, 483

Price-books: Laxton's, 302; Spons', 434

Price of bricks, 584

Priorities: Birmingham (St. Thomas) 183; Hawkesyard (Dominican) 10

Private streets works, insufficient and unreasonable, 798

Problem: a building act, 220; purification of sewage, 847

Processes, copying, for reproducing plans, 414, 481

Professional: charges, revised schedule of, 813, 839; grievances, 51; opinion, legal liability for, 267

Progress: of art in English church architecture, 124; of the architectural crafts, 1

Property, owners of, and rights to light, 444

Proposed new street, Holborn to Strand, 878

Protection: against fire in the City, 811; of ancient buildings, society for, 886; of iron, 220; of river banks from erosion, 629; of underground water supplies, 485

Prudential Assurance Co., 364

Public: buildings (composition in regard to) 82 (Government) 362, 403, 437, 472, 513 (Kildgrove) 508; Health Act, appeal under, 182; library, club designs, 197; offices, Government, 362, 403

Pulpits: Birmingham (St. Chad) 271; Fe ling, 271

Pulp, wood, in floor cloth, 586

Purification of sewage problem, 847

Purnell, E. J., Junr., Coventry, the late, 303

Putney, street improvements at, 871

**QUALIFICATION**, municipal engineer's, 630

Quantities: 69; and tenders, 219, 250

Quantity surveyor, successful claim against 512

Quested, W. R., in re, 636

Question of custom, 472

**RAILWAY** stations: Crewe, 57; Marylebone (Great Central) 57; Shrewsbury, 886

Railways: Aberlady and Gullane, 342, 546; Birmingham and Wolverhampton widening (G.W.) 29; Central London, 252; City and Brixton, 290; City and South London, 125; Gr. at Central, 546; Great Northern extensions, 511; Jungfrau, 57; Lanarkshire and Ayrshire, 848; Leen Valley, 811; Leith and Newhaven extension, 218; Manchester Canal branch (L. and Y.) 342; Savernake Forest, 777; Wadebridge and Padstow, 546; Waterloo and City, 848

Rawlinson, Sir Robert, the late, 775

Recovery of damages, re-entry and, 871

Red and yellow deal, 147, 181

Re-entry and recovery of damages, 871

Reference books on ornament and decorative arts, 89, 118

Reflected lights for interior lighting, 664

Refuse: gas, and river pollution, 620; sewerage provision for manufacturing, 656

Registration: architects' (bill) 393, 799 (society of architects and) 397, 450; plumbers', 692, 764 (ironmongers and) 473

Reject plans, power to, 798

Renaissance architecture, Later, 597

Repair of footbridges, liability for, 620

Replacing fonts, 524

Reports: museums, 633; National gallery, 835; R.I.B.A., 696

Reproducing plans, copying processes for, 414, 481

Reservoirs: Cowny Valley, 362; Staines, 654

Responsibilities: and duties, builders', 438; architects, and registration, 799

Restrictive covenant not binding on vendors, 907

Result of a strike, 907

Reviews: Academy Architecture, 3; Architectural Photography, 633; Basis of Design, 374; Bell's Cathedral Series (Exeter) 124 (Hereford) 633 (Lichfield) 302 (Norwich) 434 (Peterborough) 434 (Winchester) 302; Book of Glasgow Cathedral, 667, 745; BUILDING NEWS club designs, 86, 197, 396, 517, 700, 810; Building Trades Directory, 811; Calculation in Hydraulic Engineering, 847; Cause and Cure of Damp and Decay in Masonry, 764; Church Towers of Somersetshire, 221; Complete Perspective Course, 702; Dilapidations, 124; Engineer's Year-Book, 268; Essex Review, 124, 434, 633; Examples of Greek and Pompeian Work, 225; Examples of Old Furniture, by A. E. Chancellor, 90; Executed Designs, by Aldam Heaton and Co., 473; Fixtures, 124; Guide to the City Guildhall, 702; History of Architecture, 124; Industrial Democracy, 52; Industrial Electricity, 702; Later Renaissance Architecture in England, 597; Laxton's Builders' Price-Book, 302; Manual Training Woodwork, 847; Monumental Brass in Westminster Abbey, 692; Municipal and Sanitary Engineers' Handbook, 701; Norton - sub - Hamdon, 638; Party Structures, 847; Present Position of Sewage Purification Problem, 847; Progress of Art in English Church Architecture, 124; St. Martin's Church, Canterbury (Bell's Series) 847; Sanitary Engineering, 633; Sell's Dictionary of World's Press, 302; Sewer Gas and its Influence on Health, 302; Smith's Law of Master and Servant, 847; Specifications in Detail, 268; Spons' Architects' Price-Book, 434; Tables of Square Measurements, 123; Twyford's, a Chapter in the History of Pottery, 558; Willis's Workmen's Compensation Act, 434

Revised schedule of professional charges, 812, 839

Rhyl, arbitration at, 182

Rights to light, owners of property and, 444

Rise and development of Portland cement industry, 667

River: banks, protection of from erosion, 629; pollution and gas refuse, 620

Riverside buildings, foundations for, 735, 739, 772, 806

Riveted v. bolted joints, 523

Rome, mediæval campanili of, 261

Roof, collapse of: 525; at Abbey-mansions, Westminster, 621, 623, 668, 702, 736, 763, 887

Rooms, attic, 8

Rot, dry and wet, 436

Rough cast, waterproofing, 291

Royal: academy (architecture) 3, 537, 623 (drawings) 199 (elections) 112, 183 (Millais' pictures at) 2 (pictures) 587, 624, 639, 695; archeological institute, 799; architectural museum, 845; Egyptian tomb, 525; gold medallist, 188, 250, 291, 324, 876; institute, British architects, 116, 188, 261, 341, 405, 483, 553, 595, 654, 698 (election of council) 690, 692, 812, (presidency) 471, 473, 483 (prize drawings) 82, 85, 117 (royal gold medal) 188, 250, 291, 324, 876; Scottish academy, architecture at, 333

Royalties, brickmaking, disputes as to, 727

Roydon brick and tile co., 148

Ruskin on Lincoln cathedral, 835

**SAFE** load, 8

Safety of staging, 441

Saint: Alban (Southend-on-Sea) 7; Chad (Birmingham, pulpit) 271 (Handforth) 304; George (Liverpool) 342 (Windsor) 9; James (Gunnerybury) 270; John Baptist and Patrick (Felling) 271; Martin (Canterbury) 847; Mary (Edinburgh, cathedral) 523 (Mellor) 57 (Oldswinford) 777 (Sledmere) 885 (Wombwell) 634; Michael (Macclesfield) 508 (Manafon) 582; Ninian (Perth, cathedral) 582; Pancras (workhouse) 77, 110, 147, 251; Patrick (Dundee, R.C.) 707 (Glasgow, R.C.) 53; Paul's Ecclesiological socy., 146; Peter and Paul (Königsauter) 161; Peter (Cardiff) 634 (Maidenhead) 582; Saviour (Southwark) 873, 885; Stephen (Bournemouth) 849; Thomas (Birmingham, priory) 183

Salford experiments in sewage purification, 225

Salford experiments in sewage purification, 225

Sanitary: engineering, 633; fittings, 55; inspectors' association, 5, 269, 691; institute, 887; washable distemper, 253; work, 370, 403, 448, 479, 522

Sanitation and the fine arts, 553

Scaffolding, four-legged crane, 655

Scaling of paint, 560

Scarborough sea wall, 436

Schedule, revised, of professional charges, 812, 839

School: chapel, Mill Hill, 851; of art, Harrogate, 270

Schools: Bridlington (grammar) 849; Bushey (royal Masonic) 126, 343; East Finchley (Sunday) 58, 111, 267; public, American, 840; Sedbergh (chapel) 127; Shaw, 777; Shrewsbury (high) 60; Wadebridge (meml.) 450; Welshpool (intermediate) 850; Westbury-on-Trym (National) 91

Science and art buildings, new, 728

Scotland-yard, New, artists and, 473, 526

Scottish: academy, royal, architecture at, 333; building trades federation, 618; church architecture, 372; National Portrait gallery, 622, 728

Sculptures, early, of Argyllshire, 113

Sea: wall, Scarborough, 436; water, effect of (on cast iron) 4 (on mortar) 90

Sell's Press dictionary, 302

Serious charge against a builder, 871

Sewage: purification (problem, present position of) 847 (Salford experiments in) 225; question, royal commission, 399

Sewer: gas, 202; main drain or, 620

Sewerage provision for manufacturers' refuse, 656

Sheffield: insanitary area in, 585; society of architects and surveyors, 198, 341, 618

Ships, ventilation of, 326

Sibyls - not angels, 643

Silicate cotton, 393

Singapore town hall competition, a disclaimer, 147

Sinks, 448

Sites and buildings, new, 151

Sizes of chimney-stack, 512

Skelton, Major T. A., the late, 450

Sketches by Charles Keene, 181

Slabs, concrete, 736

Slaters' association, National, 706

Small: public library, club design, 197; suburban church designs, 393

Smith's law of master and servant, 847

Soane drawings, 82, 117

Societies: amalgamated carpenters and joiners, 558; antiquarian (Lancashire and Yorkshire) 850; archeological and architectural (Durham) 886; architects', the, 152, 269, 444, 628, 770 (and registration question) 397, 450, 485 (dinner) 591 (do., Aberdeen) 303 (do., Bristol) 562, 618, 691 (do., Devon and Exeter) 691 (do., Manchester) 303; architects and surveyors (Sheffield) 198, 341, 618; architects' benevolent, 338; architectural (Edinburgh) 198, 269, 691, 813 (Exeter) 341 (Leeds and Yorkshire) 160, 198 (Liverpool) 562, 706 (York) 434; British artists, 441; civil and mechanical engineers, 562; engineers, 341, 842; house decorators and painters, 303, 341; National footpath, 293; protection of ancient buildings, 888; St. Paul's Ecclesiological, 146

Soil pipes, defective, 512

Soirée, A.A., 657

Solid floors, 8

Solidity and straw, 187

Somersetshire church towers, 221

Soundproof walls, 906

Southampton, ancient, 588; old vault at, 707

South: Kensington (museum, completion of) 183, 230, 427, 599 (do., improvements) 799 (do., ironwork at) 666, 701, 735, 775, 808 (science and art buildings) 728, 907; London art gallery, 588; Staffordshire water supply, 324

Southwark and Vauxhall water bill, 654

Specifications: in detail, 268; model, 259, 295, 331, 368, 403, 442, 477, 515, 551, 589, 626, 660, 697, 731, 767, 804, 840, 875

Spons' architects' price-book, 434

Squabble between architect and builder, 512

Square measurements, 123

Stable fittings, 196

Stables: Bury, Lanes (co-operative) 705; club designs, 86

Stack, chimney, size of, 512

Staffordshire, South, water supply, 324

Stage mechanism, 556

Stained glass, 231, 290, 585

Staines reservoirs, 654

Staging, safety of, 441, 514

Staircases, iron, Hayward and Eckstein's, 439

Starforth, J., Edinburgh, the late, 741

States Assembly hall, Guernsey, 489

Station indicators, 524

Stations: fire brigade (Boole) 58, 230; railway (Crewe) 57 (Marylebone, Great Central) 57 (Shrewsbury) 886

Statue, Croydon municipal buildings (Whitgift) 872

Steam: hammer, cost of pile-driving with, 846; heating buildings, systems of, 523

Stedman v. Stedman, 438

Steel: and concrete combinations, 629; and wrought iron in constructional work, 53, 334, 411, 482, 518; construction, American and English, 735; wrought, constructional, 446; wrought, pipe-clips, 660

Stent, Sydney, Cape Town, the late, 775

Step, artificial stone, with leaded tread, 657

Stockwell, bd. school arbitration, 620

Stockwell, bd. school arbitration, 620

Stone: artificial, 251; carving in New York, 870; fixing, 906; lintel and architrave, 778; liquid paint, 764

Stoneyard, contractor's, is it a nuisance? 620

Strand to Holborn, proposed street, 878

Straw, solidity and, 187

Streatham, freehold sale at, 657

Street: new, Holborn to Strand, 878; what is it? 834

Streets: direct communication between, 549; new, proposed amendment of law as to, 48; works, insufficient and unreasonable, 798

Strength: comparative, of riveted and bolted joints, 523; of cast and wrought iron, 8, 59; of timber, experiments on, 293

Strike, result of a, 907

Structure, party, 847

Structures, temporary, in forecourts, 584

Students' address, by Prof. Aitchison, 116

Studies: animal, 9, 127, 231, 343, 489, 635, 887; architectural, composition in, 112

Suburban church, small, club designs, 396

Subways, rent for use of, 437

Sundials competition, 813

Sun Life assurance socy., 549, 799

Surveying, land, case of jurisprudence in, 770

Surveyor: city, libel action against, 292; diocesan, an advertising, 325

Surveyors: as arbitrators, 123, 193; district (dinner) 846 (fees) 47, 348; institution, 55, 123, 193, 397, 411, 632, 668, 699 (at Manchester) 514, 554 (dinner) 194 (examination) 155

Swimming baths, heating of, 701

Synagogue, Edinburgh, 270

Systems of steam heating buildings, 523

**TABERNACLE**, Metropolitan, burning of, 586, 726

Talent in art, discovering, 295

Taunton town hall, 230, 671, 742, 815

Taxation of land values, 3

Technical: college (Glasgow and West of Scotland) 725; education, total outlay on, 221; institutes (Gillingham) 126 (Trowbridge) 778, 851; schools (Boole) 461 (Edinburgh) 364 (Harrogate) 547 (L.C.C.) 549 (Truro) 47 (West Hartlepool) 199

Temples of Asklepios at Epidaurus and Athens, 836

Temporary structures in forecourts, 584

Tenders, quantities and, 219, 250

Tenement, the modern, 183

Tensile changes in cast iron, 439

Terra-cotta: specifications, 551, 589, 626, 660; work, 512, 548

Tests: Canadian building materials, 364; cement, 220, 906; column, 337; tile and concrete floor, 157

Thames lock at Wandsworth, proposed, 90

Theatres: Birmingham, 435; Bordesley (Imperial) 397; design of, 260; Kennington-park-road, S.E., 470; Leeds (Queen's) 161; Sheffield (Alhambra) 451

Thompson, John, Peterborough, the late, 525

Ties, hollow wall, 436

Tile and concrete floor tests, 157

Till, W. S., Birmingham, the late, 269, 399

Timber: merchant's action against architect, 220; strength of, experiments on, 293; trade terms for, 693

Tintoretto, the art of, 293

Tolstoi on art, 47

Tomb, development of in Egypt, 835

Tonite as an explosive, 113

Top-loaded buildings, 260

Tower bridge approach arbitration, 438

Towers: for civic building, study for, 851; Morecombe (novel) 849; New Brighton, 126

Town buildings, construction of, 566

Town halls: Altrincham, 779; Cardiff, 8, 112, 181; Dukinfield, 547, 619; Hoyleake, 218; Lynton, 705; Meltham, 218; Oundle, 742; Singapore, 147; Southend, 635; Taunton, 230, 671, 742, 815; Thetford, 582

Towns, amenities of, 907

Tramway, electric, Alexandra palace, 511

Travelling studentship, Cornell, 729

Trusses, Cantilever, foundations on, 90

Tunnels, Central London railway, 252

Twyfords, 558

Tyler, J., and Sons, Limited, 729

Typhoid, water-borne, 399

**UNDERGROUND** water supplies, protection of, 485

United States, public schools, 340

University, California, competition, 219

Uprights, iron, 302

Urban authorities and fair wages, 585

Useful items for builders, 338, 410

Use of subways, rent for, 437

**VALUES**, land, taxation of, 3

Value, working, of fuels, 524

Varnishes, imitation, 519

Vault, collapse of in Marylebone, 810

Venice, decoration of Doge's palace, 79

Ventilation: electrical, at Bristol, 692; mechanical, at Bristol, 221; of ships, 326

Vienna art exhibition, 399

**WAGES**, fair, urban authorities and, 586

Wallace collection, housing the, 290

Wall: boundary, Building Act and, 871; external, 778; hollow, ties, 436; sound-proof, 903	Waterloo and City railway, 848	Witherington, W. Seckham, the late, 593	Workmen's Compensation Act: architects' assistants and clerks of works and, 835; builders and, 88, 439, 728; employers' liability and, 477; Willis's handbook, 434
Walls, party: and footings under Building Act, 182, 188; notices, 325	Waterproofing: bricks, 251; rough-cast, 291	Woodenware and furniture, decoration of, 846	Work of Charles Keene, 85
Walthamstow: baths competition, 8, 59, 91, 111; a parallel to, 58, 111; recreation ground for, 908	Waterworks engineers, British association of, 654, 763	Wood: pulp in floor-cloth, 586; v. granite paving, 328; v. Monk and Newell, 727; v. Widnes corporation, 182	Works department, L.C.C., 149
Wandsworth, proposed Thames lock at, 90	Watson, Wm. M., the late, 562	Woodham v. London County Council, 549	Workshops, municipal, Battersea, 125
Ward's artificial stone step, 657	Welsh water supply for Birmingham, 727	Woodworking machinery, 870	Worthing, West, estate, sale of, 836
Warehouse, Glasgow, 489	West Worthing estate, sale of, 836	Workhouse manual training, 847	Worsleys, in re, 764
War Office competition, 692	Westminster: abbey (brasses in) 692 (a Campy Santo needed) 799; collapse of Abby-mansions, 621, 623, 688, 702, 736, 763, 887; Embankment, projected, 47; hall, condition of, 290	Workhouse infirmaries: Dorking, 305; Milton, Portsea, 342; Newton Abbot, 110; Solihull, 849; Warrington, 342	Wrought iron: and steel in constructional work, 53, 334, 411, 482, 513; strength of, 8, 59
Washable distemper, sanitary, 253	Westwood, C. J., in re, 727	Workhouses: Hastings, 510; Kirkham, Ryde, 91, 511, 548, 619; Marylebone, 776; St. Pancras, 77, 110, 147, 251; Stockport, 229; Wolverhampton, 704, 742, 778	Wrought steel pipe-clips, 560
Water: borne typhoid, 399; colour painters' institute, 387; curtains, 729; gas (carburetted, at Birkenhead) 657 (Dellwik) 729; in gas pipes, 762; sea, effect of (on cast iron) 4 (on mortar) 90; supplies, protection of underground, 485; tight, duroline not, 437; waste preventers, 408	Wet: and dry rot, 436; Road, by Wimperis, 657	Working: classes (dwellings for, Leeds) 849 (housing of) 325, 671; men's dwellings bill, 835; value of fuels, 524	<b>YEAR-BOOK</b> , engineer's, 268
	White, F. Meadows, the late, 742		Yellow and red deal, 147, 181
	Willis's Workmen's Compensation Act, 434		York architectural society, 434
			York and Marten's dinner, 221
			Yriarte, Charles, the late, 525

## INDEX TO ILLUSTRATIONS.

\* \* The Lithographic Illustrations will be found immediately following the Pages indicated.

<b>ABBEY</b> mansions, Victoria-st., 564	Hall, Cooper, and Davis) 232; Scarborough (higher grade) 708	700; Mill Hill (school) 852; private screen for (J. B. Fulton's design) 378; Richmond, Surrey (Congl.) 452; Sedburgh (school) 128; Waverley-park, Nunhead (Meth. New Connexion) 217; Windsor (St. George) 10	564 (2nd, J. Hatchard Smith) 564 (Walthamstow, 1st, J. Williams Dunford) 92; BUILDING NEWS designing club (bungalow) 708 (furniture for) 816 (convalescent home) 523 (lodge and stables) 87, 92 (public library) 200 (village church) 378, 395; clubhouse (Nuneaton, Conserv., selected, C. W. Smith) 780; fire brigade station (Boote, 2nd, Briggs and Wolstenholme) 672; library, free (Wolverhampton, selected, H. T. Hare) 416; (do., M. B. Adams) 452; Masonic institute for boys (Bushey, selected, Gordon, Lowther, and Gunton) 344 (do., 3rd, Morley and Tapper) 672; National designs (frieze, G. A. Baker) 162 (mantel decoration) G. M. Ellwood) 528 (screen, private chapel, J. B. Fulton) 378 (small art department, D. McKay) 200 (stained-glass, H. Osipvat) 416; National drawings (Arctic tern, Mrs. Dawson) 232 (birds' heads, J. J. Brownsword) 888 (fox and crow, G. Marples) 128 (francolins, owls, and rabbits, Mrs. Dawson) 636 (golden pheasant, &c., J. J. Brownsword) 344 (hare and tortoise, G. Marples) 10 (historic ornaments, J. J. Brownsword) 306 (pulpit, St. Chad's, Birmingham, W. Haywood) 272 (guest of Sir Parsifal, Violet Holden) 200; offices (Eastleigh, U.D.C., Hall, Cooper, and Davis) 600; royal academy drawings (Hermione as a statue, Mary Towgood) 92 (Spring, Mary Brickdale) 60; schools and baths (Chesterfield, 2nd, Hall, Cooper, and Davis) 232; schools (East Finchley, selected, J. Cubitt) 286, 287 (Scarborough, higher grade, 1st, Hall, Cooper, and Davis) 708; states Assembly hall (Guernsey, A. Ardron) 490; technical schools (Boote, Messrs. Woodhouse and Willoughby) 452 (Colne, selected, Woodhouse and Willoughby) 600; town-halls (Atrincham, F. W. Mee) 780 (Taunton, selected, Samson and Cottam) 816
Abbeys: Westminster (grille in Henry V. chantry) 701; Whitby (bay of choir) 528	Bolsover castle, mantels and fireplaces, 528, 780	Church, an old (Seaton) by Chas. Keene, 92	Computing machine, bevel gear, 526
Abu Simbel, colossi at, 263	Bonded warehouse, Glasgow, 490	Churches: Banwell (font) 378; Belem (Sta. Maria) 490; Birmingham (St. Chad, pulpit) 272; Brixworth (All SS.) 816; Bruton, 10; Burton Lazars (tomb at) 888; Cockington (font cover) 490; Cresswell (proposed) 232; Dundee (St. Patrick R.C.) 708; East Brent (pulpit) 249; Felling (SS. John Baptist and Patrick, pulpit) 272; Flockburgh, 128; Frome (St. John, screen from) 736, 737; Halberstadt (Our Lady) 162; Hove (All SS.) 10; Huntshill (pulpit) 378; Königslutter (SS. Peter and Paul) 162; Mantua (S. Benedetto, ironwork to reading-desk) 200; Moberley, 60; Monks Kirby, 816; Newcastle-under-Lyme (mace-stands) 774, 775; Newbold (mural monument) 888; Nottingham (St. Augustine, R.C.) 672; Richmond, Surrey (Congl.) 452; St. Mary-le-Strand (external bay) 805; Salisbury (St. Thomas, altar screen) 375; Seaton (St. Gregory, by C. Keene) 92; South Brent (pulpit) 249; village, club designs, 378, 395	Constructional work, wrought iron and steel in, 53, 54, 55, 334, 335, 336, 412, 413, 482, 483
Academy, royal, prize drawings: Hermione as a statue (Mary Towgood) 92; Spring (Mary Brickdale) 60	Bond in brickwork, 359, 404, 405	City: Charterhouse (dining-hall) 306, 416; Fleet-st., Barclay's bank, 635, 636	Convalescent home, club designs, 525
Academy as a statue (Mary Towgood) 92; Spring (Mary Brickdale) 60	Boote, central fire brigade station (2nd design, Briggs and Wolstenholme) 672	Civic building, tower of a, R. Boughton's study for, 852	Copped hall farm, Epping, 416
Alabaster pulpit at Felling, 272	Boscombe, the Parade, 378	Clare college, Cambridge, entrance to, 600	Corbeling details, 840
Albert-gate, Park-mansions, 744	Bournemouth, cripples' home, 852	Cleveland, Ohio, chamber of commerce, 816, 852	Cottage homes: Middlewood (Rochdale) 780; Mill Hill (Linen-drappers') 636
Alhambra theatre, Attercliffe, Sheffield, 452	Boys, Masonic institute for, Bushey, 344	Clare college, Cambridge, entrance to, 600	Court: Goodrich, hall of, 600; Heyhouse, Moseley, 490; hotel, Barton-on-Sea (dining-hall) 600 (entrance-hall) 814; house, Broadway, 672; theatre, Vienna, 189, 191
Altrincham town-hall, F. W. Mee's design, 780	Brent, East and South, pulpits at, 249	Clare college, Cambridge, entrance to, 600	Courtyard, Wardley hall, 162
Alum-chlne, Bournemouth, cripples' home, 852	Brewery, Munich (Court) 3, 4	Clearing drains, 522	Cover, foot, Cockington, 490
Angelo, Michael, figures of sibyls by, 378	Brickwork: 442, 443; bond in, 369, 404, 405; ornamental, 478, 479, 516, 517	Cleveland, Ohio, chamber of commerce, 816, 852	Crown theatre, Peckham, 600
"Angels" at Vatican, Michael Angelo's (sibyls) 378	Bridge girder, wind pressure on, 291	Clips, pipe, wrought-steel, 550	Crozier, French head of, 306
Animal studies: Arctic tern, 232; fox and crow, 128; francolin and owl, 636; golden pheasant, marten, ruff, &c., 344; hare and tortoise, 10; heads of crested birds, 888; lyre-bird, 490	Brigaton, artisans' dwellings, 1st design, Garrett and Gillam, 289	Club, BUILDING NEWS designing: bungalow, 708 (furniture for) 816; convalescent home, 528; lodge and stables, 87, 92; public library, 200; village church, 378, 395	Dampcourses, 369, 443
Apteryx, sketches of, 888	Brixworth, All Saints' church, 816	Clackton, holiday home for children, 708	Decoration: faience, 732; mantel, by G. M. Ellwood, 525
Architecture, Egyptian, 262, 263	Broadway, the Court house, 672	Clare college, Cambridge, entrance to, 600	Decorative metalwork, 200
Arctic terns, studies of, 232	Bromley college, 128, 145	Cockington church font cover, 490	Delphica and Erithroea, M. Angelo's
Argus pheasant, 490	Brunton church, Somerset, 10	Cockington church font cover, 490	Angels at Vatican, 378
Army and Navy-mansions, Victoria-st., S.W., 888	Buckingham Palace-mansions, 128	Coggleshall, the Lawn, 490	Demoiselle crane, 888
Art department, small, National design (D. McKay) 200	BUILDING NEWS club designs: convalescent home, 528; hillside bungalow, 708 (furniture for) 816; lodge and stables, 87, 92; public library, 200; village church, 378, 395	Colleges: Bromley, 128, 145; Cambridge (Clare) 800; Denstone (cricket pavilion at) 272	
Art galleries: South London, Peckham-road, 6, 7	Building, civic, study for tower of (R. Boughton) 852	Colonnades: Karnac, 263; Luxor, 232	
Artisans' dwellings, Brighton, 1st design, Garrett and Gillam, 289	Bungalow, hillside: club designs, 708; furniture for, do., 816	Colossi at Abu Simbel, 263	
Assembly hall, States, Guernsey, A. Ardron's design, 490	Burton Lazars church, tomb at, 888	Columns, details of Italian, 804, 805	
Attercliffe, Sheffield, Alhambra theatre, 452	Bury-st., W., Marlborough hotel, 306	Colvin estate, Waltham Abbey, cottages, 888	
Auldwood house, Seabright, N.J., staircase hall, 469	Bushey, royal Masonic institute for boys: selected design, Gordon, Lowther, and Gunton, 344; 3rd, Morley and Tapper, 672	Commerce, chamber of, Cleveland, Ohio, 816, 852	
<b>BALHAM</b> free library, 528	Business premises: Boscombe, 378; Buckingham Palace-mansions, 128; Bury-st., W. (Marlborough hotel) 306; Fleet-st., E.C. (bank) 635, 636; Hull (Reckitt's offices) 128; Loughborough (bank) 60; Munich (Court brewery) 3, 4; Reading, 507; Regent-st., W., 10; Windsor, 744; Yeovil (bank) 708	Competitions: artisans' dwellings (Brighton, 1st, Garrett and Gillam) 289; baths (Battersea, selected, F. J. Smith)	
Ball, girl playing at, statue by Walter Shott, 5	Bust of Banister Fletcher, 771		
Balustrade, wrought iron, Rothenburg, 375	Byzantine triptych, 306		
Banister Fletcher, bust of, 771	<b>CABINET</b> , old Dutch, details, 797		
Banks: Fleet-st., E.C. (Barclay's) 635, 636; Loughborough (Leicestershire) 60; river, protection of, 629; Yeovil (Capital and Counties) 708	Caen, hotel de la Bourse, 10		
Banwell church, font in, 378	Cambridge: entrance to Clare college, 600; Mass., Randolph hall, 744		
Barclay's bank, Fleet-st., E.C., 635, 636	Candlestick, the Gloucester, 306		
Barn owl, studies of, 636	Canterbury cathedral, grille in St. Anselm's chapel, 700		
Barton-on-Sea, Court hotel; dining-hall, 600; entrance and staircase, 845	Capital and Counties bank, Yeovil, 708		
Basin of fountain, Piccadilly-circus, 306	Casino, electric light, 122, 123		
Baths, public: Battersea (selected design, F. J. Smith) 564 (2nd, J. Hatchard Smith) 564; Chesterfield (and school) 2nd design, Hall, Cooper, and Davis, 232; Walthamstow, 1st design, J. Williams Dunford, 92	Casino, villa Pamphili-Doria, Rome, 545		
Battersea public baths designs: selected, F. J. Smith, 564; 2nd, J. Hatchard Smith, 564	Castles: Bolsover (mantels) 528, 780; Dieppe, 232; Hever, by Chas. Keene, 92		
Bedroom, simple, design for, 452	Cathedrals: Canterbury (grille in St. Anselm's chapel) 701; Glasgow (chapter house and choir) 744 (exterior and roof loft) 672; Lincoln, 584; Lisieux, 636; Pistoia (porch) 375; St. Alban's (slype-door fittings) 666, 667; Siena, 306		
Belem, church of Sta Maria, 490	Central fire brigade station, Boote (2nd design, Briggs and Wolstenholme) 672		
Belfast, mission building, Shankhill-road, 306	Chairs, turned work, 162		
Beni Hassan, tomb of, 162	Chalfont St. Peter, isolation home for epileptics, 272		
Berlin: Lessing theatre, 189; staircase of villa, 179	Chamber, disconnecting and inspection, 296		
Bevel-gear computing machine, 526	Chamber of commerce buildings, Cleveland, Ohio, 816, 852		
Bird, lyre, 490	Chantry, Henry V.'s, Westminster abbey, grille in, 701		
Birds' heads (J. J. Brownsword) 888	Chapels: Bushey (Masonic institute) 344; Canterbury cathedral (St. Anselm, grille)		
Birmingham, pulpit St. Chad's, measured drawings (W. Haywood) 272	Chapels: Bushey (Masonic institute) 344; Canterbury cathedral (St. Anselm, grille)		
Blawitt house, Grange-over-Sands, 272	Chapels: Bushey (Masonic institute) 344; Canterbury cathedral (St. Anselm, grille)		
Board schools: Chesterfield (2nd design,	Chapels: Bushey (Masonic institute) 344; Canterbury cathedral (St. Anselm, grille)		

Department, small art, National design (D. McKay) 200  
 Design, basis of, 375  
 Designing club, BUILDING NEWS: convalescent home, 528; hillside bungalow, 708 (furniture for) 816; lodge and stables, 87, 92; public library, 200; village church, 378, 395  
 Designs: bedroom and dining room (C. E. Vardoll) 452; BUILDING NEWS club, 87, 92, 200, 378, 395, 528, 708, 816; house, £1,000, from developments of (J. Ransome) 452; mantel decoration (National, G. M. Ellwood) 528; quest of Sir Parsifal (National, Violet Holden) 200; screen for private chapel (J. B. Fulton) 378; small art department (National, D. McKay) 200; stained glass (National, H. Osipov) 416; stencilled frieze (National, G. A. Baker) 162; tower of civic building (R. Boughton) 552  
 Desk, reading, top, Mantua, 200  
 Details: abbey (Whitby) 528; brickwork, 369, 404, 405, 442, 443, 479, 516, 517; cabinet, Dutch, 797; chamber of commerce, Cleveland, Ohio, 852; chimneys, 442; dampcourse, 443; drainage, 296, 332, 368, 522; electric lighting, 122, 123, 194, 195, 406, 407, 486, 487, 488, 521, 630, 631, 843, 844, 845; faience decoration, 733; fox, 128; hall (Wardley) 162; hare and tortoise, 10; house (Harpden, Red) 552; ironwork, S.K. museum, 666, 667, 700, 701, 736, 737, 774, 775, 808, 809, 810, 846; masonry, 637, 733, 768, 769, 804, 805, 840, 841, 876, 877; porch (Upper Langford, farm) 564; sanitary, 370, 371, 372, 408, 409, 410, 448, 449; stables, 92; staircase, Berlin, 179; terracotta, 552, 553, 590, 591, 626, 627, 661, 662, 696; wrought iron and steel, in constructional work, 53, 54, 55, 334, 335, 336, 412, 413, 482, 483  
 Dieppe, sketches from, 252  
 Dining: halls (Charterhouse) 306, 416 (Court hotel, Barton-on-Sea) 600; room (furniture for bungalow, club designs) 816 (Jacobean, design for) 452  
 Disconnecting chamber, 296  
 Door furniture: Prague, Ulm, and Wertheim, 200; St. Alban's slype, 666, 667  
 Double-spurred Francolin, 636  
 Drainage, house, 296, 332, 368, 370, 371, 372, 522  
 Drawers, chest of, 162  
 Drawings: by Chas. Keene, 92; measured (Birmingham, St. Chad's pulpit, W. Haywood) 272 (Bolsover castle, mantels, A. B. Illstone) 528, 780 (Bromley college, R. H. E. Hall) 128 (Burton Lazars and Newbold, monuments, A. E. Martin) 888 (Charterhouse dining-hall, W. H. Bourne) 306, 416 (Newnham Paddox, gates, J. J. K. Phillips) 816 (Upper Langford, Lower Court farm, T. B. Ball) 564 (Whitby abbey, A. H. Winterburn) 528; National (Arctic tern, Mrs. Dawson) 232 (Brixworth and Monks Hadley churches, A. E. Martin) 816 (fox and crow, G. Marples) 128 (francolin and rabbit, Mrs. Dawson) 636 (golden pheasant, &c., J. J. Brownsword) 344 (hare and tortoise, G. Marples) 10 (heads of crested birds, J. J. Brownsword) 888 (historic ornament, J. J. Brownsword) 306 (lyre-bird, &c., J. J. Brownsword) 490; royal academy (Spring, Mary Brickdale) 60  
 Drayton, Market, fountain, 888, 905  
 Drinking fountain, Market Drayton, 888, 905  
 Dundee, St. Patrick's R.C. church and presbytery, 708  
 Duomi: Pistoia, 375; Siena, 306  
 Durazzo palace, Genoa, entrance, 10  
 Dutch cabinet, details of, 797  
 Dwellings, artisans', Brighton, 1st design, Garrett and Gillham, 289  
**EAST:** Brent, pulpit at, 249; Finchley Congl. school, selected plan (J. Cubitt) 266, 267  
 Eastleigh U.D.C. offices, Hall, Cooper, and Davis's design, 600  
 Edgware-road, W., Metropolitan music hall, 272  
 Edinburgh royal infirmary, crane scaffolding, 655  
 Edwards, Passmore: art gallery, Peckham-road, 6, 7; children's holiday home, Clacton, 708; cripples' home, Bourne-mouth, 852; free library, Hammersmith (Leigh Hunt and Keene tablets) 60  
 Egyptian: architecture, 262, 263; mirror, 888  
 Egypt, map of, 282  
 Electric lighting details, 122, 123, 194, 195, 226, 227, 228, 298, 299, 406, 407, 486, 487, 488, 521, 630, 631, 843, 844, 881, 882, 883  
 Elephant and Castle, Newington Butts, rebuilding, 92  
 Entrance: hall, Court hotel, Barton, 845; Palazzo Durazzo, Genoa, 10  
 Epileptic home, isolation house, Chalfont St. Peter, 272  
 Epping, farm buildings, Copped hall, 416  
 Epsom, Summerdale house, 92  
 Eritrean and Delphica, M. Angelo's Angels at Vatican, 378  
 Exeter, a sketch in, by Chas. Keene, 92  
**FAIENCE** decoration details, 732  
 Farm: buildings, model, Copped hall, Epping, 416; Lower Court, Upper Langford, porch at, 564  
 Felling, church of SS. John the Baptist and Patrick, pulpit, 272

Figures: Angels at Vatican, by Michael Angelo, 378; girl playing at ball, 5; Guinevere and Lancelot, stained glass, 416  
 Finchley: East, Congl. schools, J. Cubitt's selected plan, 266, 267; Glenroy house, 744  
 Fire brigade station, Bootle (2nd design, Briggs and Wolstenholme) 672  
 Fireplaces and mantels, Bolsover castle, 525, 780  
 Fittings, ironwork, from slype door, St. Alban's cathedral, 666, 667  
 Fleet-st., E.C., Barclay's bank, 635, 636  
 Fletcher, Prof. Banister, bust of, 771  
 Flockburgh new church, 128  
 Flooring: silicate cotton in, 324; trough, 482, 483  
 Font: Banwell church, 378; cover, Cockington church, 490  
 Forest lodge, Tulse-hill, 744  
 Fountain, drinking: basin of, Piccadilly-circus, 306; Market Drayton, 888, 905  
 Four: developments of £1,000 house, by J. Ransome, 452; legged crane scaffolding, Edinburgh, 655  
 Fox, studies of the, G. Marples, 128  
 Francolins, double-spurred and painted, 636  
 Free hospital, royal, Gray's Inn-road, 416  
 Free libraries: Balham, 528; club designs, 200; Colne, 600; Hammersmith, Leigh Hunt and Keene tablets, 60; Wolverhampton (selected design, H. T. Hare) 416 (do., M. B. Adams) 452  
 Frieze, stencilled, National design (G. A. Baker) 162  
 Furniture: door, Prague, Ulm, and Wertheim, 200; for bungalow, club designs, 816; sketches, 162

**GALLERY**, art, Leighton, Peckham-road, 6, 7

Gates, entrance: Bromley college, 128; Hampton Court, 808, 809, 810; Newnham Paddox, 816  
 Gatehouse, lodge and stabling, club designs, 87, 92  
 Genoa, entrance to Durazzo palace, 10  
 Ghent, houses of the Guilds, 10  
 Girder: bridge, wind pressure on, 291; load on, 181, 251, 291  
 Girl playing at ball, W. Schott's statue, 5  
 Girl's high school, Oswestry, 60  
 Glasgow: bonded warehouse, 490; cathedral (chapter house and choir) 744 (exterior and roof loft) 672  
 Glass, stained: by Ford Madox Brown, 376; Guinevere and Lancelot (Manchester showrooms) 416  
 Glenroy house, Finchley, 744  
 Gloucester candlestick, the, 306  
 Golden pheasant, 344  
 Goodrich court, hall of, 600  
 Gosfield-st., W., house in, 232  
 Grange-over-Sands, Blawitt house, 272  
 Gray's Inn-road, Royal free hospital, 416  
 Graz, palace of Count Kottulinsky, 600  
 Great-eared owl, 636  
 Grebe, crested, 888  
 Greek patera, handle of, 306  
 Grilles: Henry V. chantry, Westminster abbey, 701; St. Anselm's chapel, Canterbury cathedral, 700  
 Guernsey, States Assembly hall (A. Ardron's design) 490  
 Guilds houses, Ghent, 10  
 Guinevere, Queen, stained glass, 416

**HALBERSTADT**, church of Our Lady, 162

Halls: Auldwood, Seabright, N. J. (staircase) 469; Barton Court hotel (dining) 600; Cambridge, Mass. (Randolph) 744; Charterhouse (dining) 306, 416; Colne (public) 600; Copped, Epping (farm) 416; Goodrich Court, 600; Guernsey (States Assembly, A. Ardron's design) 490; Karnac (hypostyle) 263; Wardley, 159, 162  
 Hammersmith free library, Keene and Leigh Hunt tablets, 60  
 Hampton Court screen from, 808, 809, 810  
 Handle: from Ulm, 200; of Greek patera, 306  
 Hare: and tortoise, drawings by G. Marples, 10; drawings by Mrs. Dawson, 636  
 Harpenden, the Red house, 852  
 Hartlepool, West, technical schools, 200  
 Hawick, house near, 128  
 Hawkesyard priory, Rugeley, 10  
 Head of French crozier, 306  
 Heads of crested birds (J. J. Brownsword) 888  
 Hedgehog Inn, Nottingham, 60  
 Henry V. chantry, Westminster abbey, grille, 701  
 Hermione as a statue, by Mary Towgood, 92  
 Hever castle, by Chas. Keene, 92  
 Higher grade school, Scarborough, 708  
 High school (girls') Oswestry, 60  
 Hillside bungalow, club design: 708; furniture for do., do., 816  
 Historic ornament, 306  
 Hofbräuhaus, Munich: 3; staircase in, 4  
 Holborn: Royal music hall, 10; to Strand, proposed new street, 879  
 Holiday home for children, Clacton, 708  
 Hollow walls, 369  
 Homes: cottage (Middlewood, Rochdale) 780 (Mill Hill, Linendrapers') 636; convalescent (club designs) 525; cripples' (Bournmouth) 852; epileptics (Chalfont, isolation house) 272; holiday, for children (Clacton) 708

Hospital, Gray's Inn-road (Royal Free) 416  
 Hotels: Barton-on-Sea (Court, dining-hall) 600 (do., entrance hall) 845; Bury-st., W. (Marlborough) 306; Caen (de la Bourse) 10; Newington Butts (Elephant and Castle) 92; Rhos-on-Sea (Rhos abbey) 528; Stuttgart (Marquardt, reading room) 200  
 Hot-water system, 690  
 House drainage, 296, 332, 368, 370, 371, 372, 522  
 Houses: Auldwood, Seabright, N.J. (staircase hall) 469; Blawitt, Grange-over-Sands, 272; Buckingham palace-mansions, 128; bungalow (club designs) 708; Caen (hotel de la Bourse) 10; Chester (Hooles-road) 272; Colvin estate, Waltham Abbey, 888; Court, Broadway, 672; Court Hey, Moseley, 490; Dieppe, 232; Forest lodge, Tulse-hill, 744; Genoa (Durazzo palace, entrance) 10; Ghent (Guids) 10; Glenroy, Finchley, 744; Goodrich court (hall of) 600; Gosfield-st., W., 232; Hawick, 128; Lawn, Coggeshall, 490; Medmenham, 888; Newdigate-place, Surrey, 306; Pamphili, Doris, Rome, 545; Paris (Maison de Rapport) 725; Park-mansions, Albert-gate, 744; Red, Harpenden, 852; Shackelford, Surrey, 780; Summerdale, Epsom, 92; Surbiton, 232; Sutton, Surrey, 672; Thorpe Mandeville, 780; £1,000, four developments of (J. Ransome) 452; Tileworth, St. Leonard's (coachman's cottage) 833; Upper Langford (Court farm, porch) 564; Victoria-st., mansions (Abbey) 564 (Army and Navy) 888; Wardley (hall) 159; Wood Norton, King's Norton, 490  
 Hove, All Saints' parish church, 10  
 Hull, Reckitt's offices, 128  
 Humming-birds, long-tailed and ruby, 490  
 Hunt, Leigh, memorial tablet, Hammersmith free library, 60  
 Huntspill church, pulpit in, 378  
 Hypostyle hall, Karnac, 263

**INCANDESCENT**: lamps, electric, 844; light, Biling's, 690

Infirmary, Edinburgh Royal, crane scaffolding, 655  
 Inns: Newington Butts (Elephant and Castle, rebuilding) 92; Nottingham (Hedgehog) 60  
 Institutes: Bootle (technical, design, Woodhouse and Willoughby) 452; Leighton, Peckham-road, S.E., '6, 7; Masonic, for boys, Bushey (selected design, Godon, Lowther, and Gunton) 344 (3rd, Morley and Tapper) 672  
 Iron: and steel, wrought, in constructional work, 53, 54, 55, 334, 335, 336, 412, 413, 482, 483; fittings, slype door, St. Alban's cathedral, 666, 667; grilles (Canterbury cathedral) 700 (Westminster abbey) 701; mace stands (Newcastle-under-Lyme) 774, 775; screens (Frome, St. John) 736, 737 (Hampton Court) 808, 809, 810; trivets (S. K. museum) 846  
 Isolation home for epileptics, Chalfont, 272

**KARNAC**, hypostyle hall, 263

Keene, Chas.: drawings by, 92; memorial tablet, Hammersmith free library, 60  
 Kensington, South, museum, ironwork, 666, 667, 700, 701, 736, 737, 774, 775, 808, 809, 810, 846  
 Kingfishers, American, 344  
 King's Norton, Wood Norton house, 490  
 Königslutter, church of SS. Peter and Paul, 162

**LAMPS**, electric: art, 881, 882, 883; incandescent, 814

Lancelot, Sir, stained glass, 416  
 Langford, Upper, porch at Lower Court farm, 564  
 Lawn house, Coggeshall, 490  
 Leeds, Queen's theatre, 162  
 Leicestershire bank, Loughborough, 60  
 Leigh Hunt memorial tablet, Hammersmith free library, 60  
 Leighton institute, Peckham-road, S.E., 6, 7  
 Lessing theatre, Berlin, 189  
 Libraries, free: Balham, 528; club designs, 200; Colne, 600; Hammersmith, Leigh Hunt and Keene tablets, 60; Wolverhampton (selected design, H. T. Hare) 416 (M. B. Adams) 452  
 Light, Biling's incandescent, 690  
 Lighting, electric, details, 122, 123, 194, 195, 226, 227, 228, 298, 299, 406, 407, 486, 487, 488, 521, 630, 631, 843, 844, 881, 882, 883  
 Lincoln cathedral, west front, by P. de Wint, 564  
 Linendrapers' cottage homes, Mill Hill, 636  
 Lisieux cathedral, 636  
 Load on girder, 151, 251, 291  
 Lodge and stables, BUILDING NEWS club designs, 87, 92  
 Long-tailed humming bird, 490  
 Loughborough, Leicestershire bank, 60  
 Lower Court farm, Upper Langford, porch of, 564  
 Luxor, colonnade, 263  
 Lyre-bird, 490

**MACE** stands, Newcastle-under-Lyme, 774, 775

Machine, bevel-gear computing, 526  
 Maison de Rapport, Paris, plan, 725  
 Manchester showroom, stained glass (Guinevere and Lancelot) 416

Manhole, 296  
 Mansions: Albert-gate (Park) 744; Buckingham palace, 128; Victoria-street, S.W. (Abbey) 564 (Army and Navy) 888  
 Mantel decoration, by G. M. Ellwood, 528  
 Mantels, Bolsover castle, 528, 780  
 Mantua, S. Benedetto, ironwork to reading desk, 200  
 Map of Egypt, 262  
 Market Drayton, fountain, 888, 905  
 Marlborough hotel, Bury-st., W., 306  
 Masonic institute for boys, Bushey: selected design, Godon, Lowther, and Gunton, 344; 3rd, Morley and Tapper, 672  
 Masonry details, 697, 733, 768, 769, 804, 805, 840, 841, 876, 877  
 Measured drawings: Birmingham, pulpit at St. Chad's (W. Haywood) 272; Bolsover castle, fireplaces (A. B. Illstone) 528, 780; Bromley college (R. H. E. Hall) 128, 145; Charterhouse, dining-hall (W. H. Bourne) 306, 416; Newnham Paddox, wro't iron gates (J. J. K. Phillips) 816; Upper Langford, porch of Lower Court farm (T. B. Ball) 564; Whitby abbey (A. H. Winterburn) 528  
 Measuring instruments, electrical, 406, 407  
 Medmenham, house at, 888  
 Metalwork, decorative, 200  
 Metropolitan music hall, Edgware-road, 272  
 Michael Angelo's figures of sibyls, 378  
 Middlewood, Rochdale, cottage homes, 780  
 Mill Hill: Linendrapers' cottage homes, 636; school, new chapel, 852  
 Mirror, Egyptian, 306  
 Mission building, Belfast, 306  
 Moberley church, Cheshire, 60  
 Model: farm, Copped hall, Epping, 416; specifications, 296, 332, 368, 369, 404, 405, 442, 443, 478, 479, 516, 517, 552, 553, 590, 591, 626, 627, 661, 662, 696, 697, 732, 733, 768, 769, 804, 805, 810, 841, 876, 877  
 Monks Kirby church tower, 816  
 Monuments: Burton Lazars, 888; Newbold (mural) 888  
 Moseley, Court Hey house, 490  
 Munich, Kgl. Hofbräuhaus: 3; staircase in, 4  
 Mural monument, Newbold, 888  
 Museum, South Kensington, ironwork at, 666, 667, 700, 701, 736, 737, 774, 775, 808, 809, 810, 846  
 Music halls: Edgware-road (Metropolitan) 272; Holborn (Royal) 10

**NATIONAL**: designs (mantel decoration, G. M. Ellwood) 528 (screen for private chapel, J. B. Fulton) 378 (small art department, D. McKay) 200 (stained glass, Guinevere and Lancelot, H. Osipov) 416 (stencilled frieze, G. A. Baker) 162; drawings (Arctic tern, Mrs. Dawson) 232 (birds' heads, J. J. Brownsword) 888 (Brixworth and Monks Kirby churches, A. E. Martin) 816 (fox and crow, G. Marples) 128 (francolin, owls, and rabbit, Mrs. Dawson) 636 (golden pheasant, &c., J. J. Brownsword) 344 (hare and tortoise, G. Marples) 10 (historic ornament, J. J. Brownsword) 306 (lyre-bird, &c., J. J. Brownsword) 490 (pulpit, St. Chad's, Birmingham, W. Haywood) 272 (Quest of Sir Parsifal, Violet Holden) 200 (tomb, Barton Lazars, and monument, Newbold, A. E. Martin) 888; measured drawings (mantels, Bolsover castle, A. B. Illstone) 528, 780 (wrought-iron gates, Newnham Paddox, J. J. K. Phillips) 816

Newbold church, mural monument, 888  
 Newcastle-under-Lyme, mace stands, 774, 775  
 Newdigate-place, Surrey, 306  
 Newington Butts, rebuilding of Elephant and Castle, 92  
 Newnham Paddox, wro't iron gates, 816  
 New street, Strand to Holborn, 879  
 Norton, King's, Wood Norton house, 490  
 Notes: electric lighting, 122, 123, 194, 195, 226, 227, 228, 298, 299, 406, 407, 486, 487, 488, 521, 630, 631, 843, 844, 881, 882, 883  
 Nottingham, St. Augustine's R.C. church, 672  
 Nottingham: Hedgehog Inn, 60; St. Augustine's R.C. church, 672  
 Nuneaton Conservative clubhouse, 780  
 Nunhead, chapel and schools, Waverley-park, 217

**OFFICES**: Eastleigh (U.D.C., Hall, Cooper, and Davis's design) 600; Hull (Reckitt's) 128; Surbiton (post) 378; Victoria-st (Abbey-mansions) 564

Old church, an (Seaton) Chas. Keene, 92  
 Opera house, Paris, detail of, 191  
 Ornamental brickwork, 478, 479, 516, 517  
 Ornament, historic, 306  
 Oswestry, girls' high school, 60  
 Owls, barn and great-eared, 636

**PAINTED**: francolin, 636; quail, 636

Palaces: Genoa (Durazzo, entrance hall) 10; Graz (Kottulinsky) 617; Prague (Hradschin, door furniture) 200  
 Pamphili-Doris villa, Rome, 545  
 Paradise, bird of, 490  
 Paris: Maison de Rapport, plan, 725; opera house, detail of, 191  
 Park-mansions, Albert-gate, 744  
 Parsifal, quest of Sir, by V. Holden, 200  
 Passmore Edwards: art galleries, Peckham-road, 6, 7; children's holiday home, Clacton, 708; cripples' home, Bourne-

mouth, 852; free library, Hammersmith (Leigh Hunt and Keene tablets) 60  
Pastoral staff, head of, 306  
Patera, handle of Greek, 306  
Pavilion, cricket, Denstone college, 272  
Peckham-road, S.E.: Leighton institute, 67; theatre, 600  
Pelican, sketches of, 888  
Pheasants: argus, 490; golden, 344; Reeves', 490  
Piccadilly-circus, basin of fountain, 306  
Pigeon, crowned, 888  
Pipe-clips, wrought steel, 560  
Pistola cathedral, porch, 375  
Plans: art department, small (National design, D. McKay) 200; artisans' dwellings (Brighton, 1st, Garrett and Gilham) 289; banks (Fleet-st., E.C., Barclay's) 635 (Loughborough, Leicestershire) 60; baths (Battersea, selected, F. J. Smith) 564 (do., 2nd, J. Hatchard-Smith) 564; bungalow (club designs) 708; business premises (Windsor) 744; chapels (Mill Hill, school) 852 (St. dbergh school) 128 (Waverley-park, Nunhead, Meth. New Conn.) 217; Charterhouse, the, 416; churches (Brixworth, All SS.) 816 (Cresswell) 232 (Dundee, St. Patrick) 708 (Flockburgh) 128 (Nottingham, St. Augustine, R.C.) 672 (Richmond, Surrey, Congl.) 452 (village, club designs) 378, 395; clubhouse (Nuneaton, Conserv.) 780; college (Bromley) 145; convalescent home (club designs) 528; cottage homes (Mill Hill, Linendrapers') 686; cottages (Colvin estate, Waltham Abbey) 888; cripples' home (Bournemouth) 852; drainage, house, 296, 332, 368; epileptics' home (Chalfont, isolation house) 272; farm buildings, Copped hall, Epping, 416; fountain (Market Drayton) 906; galleries, art (Peckham-road, Leighton institute) 6, 7; gates (Newnham Paddock) 816; halls (Cambridge, Mass., Randolph) 744 (Karnac, hypostyle) 263 (Wardley) 159, 162; high school (Oswestry) 60; holiday home, children's (Clacton) 708; hotels (Bury-st., W., Marlborough) 306 (Rhos-on-Sea, Abbey) 528; houses (Albert-gate, Park-mansions) 744 (Chester) 272 (Court Hey, Moseley) 490 (four developments of a £1,000) 452 (Glenroy, Finchley) 744 (Hawick) 128 (Newdigate-place, Surrey) 306 (Paris, maison de Rapport) 725 (Red, Harpenden) 852 (Shackleford) 780 (Summerdale, Epsom) 92 (Surbiton) 232 (Sutton, Surrey) 672 (Thorpe Mandeville) 780 (Wood Norton, King's Norton) 490; inn (Nottingham, Hedgehog) 60; libraries, free (Balham) 528 (Wolverhampton) 416 (do., M. B. Adams's design) 452; Masonic boys' institute, Bushey (selected, Gordon, Lowther, and Gunton) 344 (3rd, Morley and Tapper) 672; mission building (Belfast) 306; offices (Eastleigh, U.D.C., Hall, Cooper, and Davis's design) 600 (Hull, Reckitt's) 128; pavilion, cricket (Denstone college) 272; post office (Surbiton) 378; presbytery (Dundee, St. Patrick) 708; priory (Hawkesyard, Rugeley) 10; Ramesseum, 263; school and bath (Chesterfield, Hall, Cooper, and Davis) 232; schools (East Finchley, selected, J. Cubitt) 266, 267 (Scarborough, higher grade) 708; stabling (and lodge gatehouse, club designs) 87, 92 (St. Leonard's) 833; States Assembly hall (Guernsey, design by A. Ardron) 490; street (proposed, Strand to Holborn) 879; technical schools (Colne) 600 (West Hartlepool) 200; theatres (Attercliffe, Sheffield, Alhambra) 452 (Leeds, Queen's) 162 (Peckham) 600; tomb (Beni-Hassan) 262; town hall (Taunton) 816; warehouse (Glasgow, bonded) 490; workhouse (Shoreham) 744  
Porch: Lower Court farm, Upper Langford, 564; Pistola cathedral, 375  
Post office, Surbiton, 378  
Prague, door furniture, palace of Hradscin, 200  
Premises: Boscombe, 878; Buckingham palace-mansions, 128; Fleet-st. (Barclay's) 635, 636; Gosfield-st., W., 232;

Hull (Reckitt's) 128; Loughborough (bank) 60; Munich (brewery) 3, 4; Reading, 507; Regent-st., W., 10; Victoria-st., S.W. (Abbey-mansions) 664 (Army and Navy do.) 883; Windsor, 744; Yeovil (bank) 708  
Pressure, wind, on bridge girders, 291  
Preventers, water-waste, 408, 409, 410  
Priory, Hawkesyard, Rugeley, 10  
Private chapel, screen for, J. B. Fulton's design, 378  
Proposed church, Cresswell, 232  
Proscenium box, Court theatre, Vienna, 191  
Protection of river banks, 629  
Public: baths (Battersea, selected design, F. J. Smith) 564 (2nd, J. Hatchard Smith) 564 (Chesterfield, 2nd, Hall, Cooper, and Davis) 232 (Walthamstow, 1st design, J. W. Dunford) 92; hall (Colne) 600; libraries (club designs) 200 (Colne) 600 (Hammersmith, tablets in) 60 (Wolverhampton) 416 (do., M. B. Adams's design) 452  
Pulpits: Birmingham (St. Chad) 272; Felling (SS. John Baptist and Patrick) 272; Somersetshire (East Brent and South Brent) 249 (Huntspill) 878

**QUAIL**, painted, 636  
Queen Guinevere, stained glass, 416  
Queen's theatre, Leeds, 162  
Quest of Sir Parsifal, by Violet Holden, 200

**RABBITS**, studies of, 636  
Raimund theatre, Vienna, 190  
Ramesseum, plan of, 263  
Randolph hall, Cambridge, Mass., 744  
Reading: business premises, Friar-st., 507; desk, S. Benedetto, Mantua, 200; room, hotel Marquardt Stuttgart, 200  
Rebuilding of Elephant and Castle, 92  
Reckitt's offices, Hull, 128  
Red house, Harpenden, 852  
Reeves' pheasant, 490  
Regent-st., W., business premises, 10  
Rhos-on-Sea, Rhos Abbey hotel, 528  
Richmond, Surrey, Congl. church and lecture hall, 452  
River banks, protection of, 629  
Rochdale cottage homes, Middlewood, 780  
Rome: Casino, villa Pamphili-Doria, 545; Michael Angelo's Sybils at Vatican, 378  
Rood loft, Glasgow cathedral, 672  
Rothenburg, wro't iron balustrade, 375  
Royal: academy drawings (Hermione as a statue, Mary Towgood) 92 (Spring, Mary Brickdale) 60; Free hospital, Gray's Inn-road, 416; Masonic institute for boys, Bushey (selected design, Gordon, Lowther, and Gunton) 344 (3rd design, Morley and Tapper) 672; music hall, Holborn, 10  
Ruff, sketch of, 344  
Rugeley, Hawkesyard priory, 10

**SAINT**: Alban's cathedral (slype door fittings) 666, 667; Anselm's chapel, Canterbury cathedral (grille) 700; Augustine (Nottingham, R.C.) 672; Chad (Birmingham, pulpit) 272; George (Windsor, chapel) 10; Gregory (Seaton) 92; John the Baptist and Patrick (Felling, pulpit) 272; Leonard's (stabling and cottage) 816; Maria (Belem) 490; Mary-le-Strand (bay of) 805; Patrick (Dundee, R.C.) 708; Peter and Paul (Königsplutler) 162; Thomas (Salisbury, altar screen) 375  
Salisbury, altar screen, St. Thomas' church, 375  
Sanitary work, 370, 371, 372, 408, 409, 410, 448, 449  
Scarfolding, crane, Edinburgh infirmary, 655  
Scarborough, higher grade school, 708  
Schools: Bootle (technical, Woodhouse and Willoughby's design) 452; Chesterfield (and baths) (2nd design, Hall, Cooper, and Davis) 232; Colne (technical) 600; East Finchley (Congl., selected plan, J. Cubitt) 266, 267; Mill Hill (chapel) 852; Oswestry (girls' high) 60; Scarborough (higher grade) 708; Sedbergh (chapel) 128; West Hartlepool (technical) 200

Screen: from Hampton Court, 808, 809, 810; from St. John's, Frome, 736, 737; private chapel (J. B. Fulton's design) 378; St. Thoms, Salisbury, 375; Spanish iron, 306  
Seabright, N. J., staircase hall, Auldwood house, 469  
Seaton church, sketch by Chas. Keene, 92  
Sections: art department (National design, D. McKay) 200; artisans' dwellings, Brighton (1st design, Garrett and Gillham) 289; bay of house (Harpenden) 852; bungalow (club designs) 708; church, village (club designs) 378, 395; club (Nuneaton, Cardiff) 780; drainage, 296; hall (Wardley) 162; home, convalescent (club designs) 528; home, epileptics' (Chalfont) 272; hot-water system, 690; libraries, free (club designs) 200 (Wolverhampton) 416; manhole, 296; Masonic institute for boys (Bushey) 344; school and bath (Chesterfield, 2nd design, Hall, Cooper, and Davis) 232; stabling and gatehouse (club designs) 87, 92; town hall (Taunton) 816  
Sedbergh school chapel, 128  
Shackleford, Surrey, house at, 780  
Sheffield, Alhambra theatre, 452  
Shops: Boscombe-parade, 378; Windsor, 744  
Shoreham, new workhouse, 744  
Siema cathedral, 306  
Silicate cotton between floors, 324  
Sinks, 448, 449  
Sir Parsifal, quest of, by Violet Holden, 200  
Sketches: by C. Keene (Exeter and Seaton) 92; decorative metalwork, 200; from Dieppe, 232; furniture, 162  
Slype door fittings from St. Alban's 666, 667  
Small art department, National design (D. McKay) 200  
Solent yacht club, Yarmouth, I.W., 636  
Somerset house, window of, 769  
Somersetshire: font (Banwell) 378; pulpits (East Brent and South Brent) 249 (Huntspill) 378  
South: Brent, pulpit, 249; Kensington museum, ironwork (grille, Canterbury cathedral) 700 (do., Westminster abbey) 701 (mace stands, Newcastle-under-Lyme) 774, 775 (screen, Frome, St. John) 736, 737 (do., Hampton Court) 808, 809, 810 (slype door fittings, St. Alban's cathedral) 666, 667 (trivets) 846; London art galleries, Peckham-road (plans) 6, 7  
Spanish iron screen, 306  
Specifications, model, 296, 332, 368, 369, 404, 405, 442, 443, 478, 479, 516, 517, 552, 553, 590, 591, 626, 627, 661, 662, 696, 697, 732, 733, 768, 769, 804, 805, 840, 841, 876, 877  
Spring, R.A. prize drawing (Mary Brickdale) 60  
Stabling: and cottage, St. Leonard's, 833; and lodge gatehouse, club designs, 87, 92  
Staff, pastoral head of, 306  
Stained glass: by Ford Madox Brown, 376; Guinevere and Lancelot (Manchester showroom) 416  
Staircases: Auldwood, Seabright, N. J., 469; Barton (Court hotel) 845; Berlin (villa) 179; Graz (palace) 617; Munich, 4  
Stands, mace, Newcastle-under-Lyme, 774, 775  
Stand, Roman tripod, 306  
States Assembly hall, Guernsey, A. Ardron's design, 490  
Station, fire brigade, Bootle, 2nd design, Briggs and Wolstenholme, 672  
Statues: girl playing at ball (W. Shott) 5; Hermione (Mary Towgood) 92  
Steel, wrought: in constructional work, 53, 54, 55, 334, 335, 336, 412, 413, 482, 483; pipe-clips, 560  
Stencilled frieze, National design (G. A. Baker) 162  
Steyning union workhouse, Shoreham, 744  
Stoat, sketch of, 344  
Strand to Holborn, new street, 879  
Street: proposed new, Strand to Holborn, 879; scene in Exeter, by Chas. Keene, 92  
Studies, animal, 10, 128, 232, 344, 490, 636, 888  
Stuttgart, reading-room, hotel Marquardt, 200  
Summerdale house, Epsom, 92

Surbiton: house at, 232; post office, 378  
Sutton, Surrey, house at, 672

**TABLES**, oak, 162  
Tablets, memorial, Keene and Leigh Hunt, Hammersmith free library, 60  
Taunton town hall, 816  
Technical schools: Bootle (Woodhouse and Willoughby's design) 452; Colne, 600; West Hartlepool, 200  
Temples, Egyptian, 262, 263  
Terns, Arctic, drawings of by Mrs. Dawson, 232  
Terracotta details, 552, 553, 590, 591, 626, 627, 661, 662, 696  
Testing, electric circuit, 630, 631  
Theatres: Attercliffe, Sheffield (Alhambra) 452; Berlin (Lessing) 189; Leeds (Queen's) 162; Peckham (Crown) 600; Vienna (Court), 189, 191 (Raimund) 190  
Thorpe Mandeville, house at, 780  
Tilework, St. Leonard's, coachman's cottage and stables, 833  
Tombs: Beni-Hassan, plan, 262; Burton Lazars, 888  
Tortoise, hare and, drawings by G. Marples, 10  
Toucan, head of, 878  
Tower of civic building, R. Boughton's study for, 852  
Town halls: Altrincham (F. W. Mee's design) 780; Taunton, 816  
Tripod stand, Roman, 306  
Triptych, Byzantine, 306  
Triton struggling with serpents, 306  
Trivets, South Kensington museum, 846  
Trough flooring, 482, 483  
Tulse-hill, Forest lodge, 744

**ULM**, handle at, 200  
Upper Langford, porch at Lower Court farm, 564  
Urban district council offices, Eastleigh, Hall, Cooper, and Davis's design, 600

**VATICAN**, Michael Angelo's Sybils, 378  
Victoria-st., mansions: Abbey, 564; Army and Navy, 888  
Vienna: Court theatre, 189, 191; Raimund Court theatre, 190  
Village churches, club designs, 378, 395  
Villa Pamphili-Doria, Rome, 545

**WALLS**, damp-proof, 369, 443  
Waltham Abbey, cottages on Colvin estate, 888  
Walthamstow public baths, 1st design, J. Williams Dunford, 92  
Wardley hall, Lanes, 159, 162  
Warehouse, bonded, Glasgow, 490  
Waste preventers, water, 408, 409, 410  
Water-waste preventers, 408, 409, 410  
Waverley-park, Nunhead, Meth. New Connexion chapel and schools, 217  
Wertheim, door furniture at, 200  
West Hartlepool, technical schools, 200  
Westminster: abbey, grille in Henry V. chantry, 701; Victoria-st., mansions (Abbey) 564 (Army and Navy) 888  
Whitby Abbey, measured drawings (A. H. Winterburn) 528  
Windows, classical: 768; St. Mary-le-Strand, 805; Somerset house, 769  
Wind pressure on bridge, 291  
Windsor: premises, Thames-street, 744; St. George's chapel, 10  
Wolverhampton free library designs: selected, H. T. Hare, 416; M. B. Adams, 452  
Wood Norton house, King's Norton, 490  
Workhouse (Steyning) Shoreham, 744  
Wrought: iron and steel in constructional work, 53, 54, 55, 334, 335, 336, 412, 413, 482, 483; ironwork fittings, slype door, St. Alban's, 666, 667; steel pipe-clips, 560

**YARMOUTH, I.W.**, Solent yacht club, 636  
Yacht club, Solent, Yarmouth, I.W., 636  
Yeovil, Capital and Counties bank, 708

# THE BUILDING NEWS

## AND ENGINEERING JOURNAL.

### PROGRESS OF THE ARCHITECTURAL CRAFTS.

THE great impetus given to building industries during the last decade or two has very considerably altered the relative positions and functions of the trades and crafts connected with building. In the architectural profession itself many similar changes have taken place. A variety of experts have arisen who have interfered very much with the duties and province of the architect's profession. The "all-round" practitioner has felt it as seriously as the architect pure and simple, for he has been ousted in turn from several important by-paths of the profession. Agricultural and sanitary buildings, like homesteads, stables, labourers' cottages, &c., have now fallen to a class of practitioners who have made them special studies. A good deal of sanitary work that used to fall to the profession is now done by sanitary engineers. Workhouses, hospitals, and schools form almost distinct branches of the profession, and have been relegated to men who have made them specialities; and then we have those who devote themselves almost exclusively to churches, theatres, factories, technical schools, and breweries. On the otherside of the architect's vocation, there are those now who overlap him, like decorative artists, designers of furniture and wall decoration. Half a century ago most of these things came into the hands of architects; but, of course, they were in a much less degree specialised or organised branches than they are now. By the gradual process of division of labour, by the advance of science and scientific classification, these several kinds of work have assumed a more definite form, the consequence of which is that one kind of building is quickly differentiated from another, and, so to speak, begin to crystallise under distinct laws. So that, taking two obvious instances, a hospital and an elementary school, they are quite different buildings to what they once were. There was no idea of a well classified and equipped ward for fever or infectious patients; nor had the ideas of educating the young been brought under any kind of scientific investigation nor was there any Elementary Education Act; nor had the State taken any trouble to bring evidence together by Blue Books, the result of which has been that facts and evidence have been adduced, and the system of planning and constructing schools has been completely revolutionised. Even in such buildings as industrial dwellings and labourers' cottages, hygiene, the value of light and air and ventilation, and the physical requirements of each inmate have introduced fundamental changes. And in every case we find that

directly any class of building has undergone Government inquiry or investigation as to sanitary and other matters, the door has been opened to specialists and others to enter, and what had been previously the architect's province has been given over to the engineers or another class of practitioners.

We may take two kinds of professional vocations which have bifurcated from the parent stem. They are represented by the engineer on one side, and the decorative artist on the other side. What a considerable change in the architect's profession this division has made! At almost every step the architect is now confronted by the engineer. The work of each is overlapped by the other. The design of every warehouse or shop in which iron is introduced in floors, girders, or columns, is controlled more or less by the engineer; his interference is felt in the design of iron roofs over markets, baths, theatres, and a host of other buildings. In the construction of the galleries of theatres the architect has to consult him, as also in the hydraulic machinery of the stage, in lifts, and the engineering work of baths. Certain structures like bridges and viaducts, once in the hands of architects, are now carried out by engineers. And the architect's work often overlaps that of the engineer. Modern hotels, public baths and washhouses are structures in which engineering details largely enter. And has not this specialisation of branches been productive of progress? If we lose much of the unity and harmony of the old work, we have gained precision, economy in the use of material. Our churches, hospitals, theatres, baths and washhouses are all the better for being designed by men who have devoted their experience and study to them. They move in a more restricted sphere, but they are more likely to achieve success than if they dabbled with the numerous problems of the day.

But to come to our main thesis: the building trades are in frequent conflict owing to the progress made in various directions. Thus a new invention or process comes into use which lies outside the trade of a particular craft; and this process may be connected with other trades. To take a few examples. Iron pipes have come into use for sanitary purposes, which before were entirely intrusted to the plumber. The latter resents the introduction of iron for waste and other pipes instead of lead, and both the trades of the engineer and plumber complain of the interference. Furnishing ironmongers and sanitary specialists now overlap largely the duties of the plumber. Again, several new inventions have sprung into existence which are taking the bread out of the mouths of the joiners and carpenters. One instance is

that of horticultural building, which is now a special trade. Here the patentee of a new process of sash construction or patent roof-glazing often supplants the carpenter and joiner; iron or steel rolled sash-bars, or some new watertight glazing interferes with both the joiner and the glazier. The maker of iron casements has also interfered with the same trade. The patentee of new window-sashes in wood is another trespasser on the joiners' trade.

Shop-fitters form a large class of tradesmen who take the bread out of the mouths of ordinary joiners by supplying internal fittings for shops. In the decorative trades the various new processes for wall-hangings and dadoes, new kinds of plasters and fabrics, have seriously overlapped the plasterer and paperhanger. Relief decoration in fibrous plaster, and materials like tiles, embossed leathers, wood-veneers, have interfered with joiners, plasterers, paperhangers, and carvers. The carpenter also has been largely ousted by the makers of fire-proof floors, who, in lieu of timber beams and double-framed floors, have introduced iron, concrete, and pottery. We may go on to mention other introductions, like machine-made joinery, ornamental brick-work, and terracotta, to show how many of the old trades are handicapped. Each tradesman claims the new process which overlaps his trade as his own, because the same material is used, or the object attained by its use belongs to him. Mr. Sidney Webb, in his new work we noticed last week, mentions several examples of the overlap between two trades, notably in the modern industry of iron shipbuilding, where the demarcation between the trades of plumbers, engineers, and fitters and others cause many disputes. He points to the disastrous chaos into which the disputes about demarcation threw the great industries of Tyneside between 1890 and 1893, which involved the stoppage of large establishments and the idleness of thousands of artisans. The principle that every trade shall have the right to earn its bread without the interference of outsiders appears a just one, and is guarded by every trade. These disputes arise often from the custom of subletting portions of the work of a specialised kind, thereby depriving the ordinary tradesman of his work. But it is difficult to fence off every craft from encroachment. To define the right to a trade is almost impossible. Some new process or unfamiliar material is the bone of contention. The example given by Mr. Webb can be easily applied to a building. The shipwright claims the right to all that concerns the construction and fitting up of a ship. "But the modern ship includes everything that is found in a luxurious hotel, and the

shipwright, on this interpretation, would not only have to work in steel as well as in wood, but would also have to be an accomplished engineer, boilermaker, brass-finisher, plumber, joiner, cabinetmaker, polisher, upholsterer, decorator, and electric-light and bell-fitter." He observes, the dividing line between these crafts cannot be determined by the tools or the materials used. The modern steamer requires the use not only of the tools used by the shipwright, but also of those employed by the other trades, so that if each tradesman were limited to his own tools much confusion would be created—each workman would be waiting to do his particular part, and there would be overlapping or omission, in many cases prejudicial to the integrity of the structure. And this is what takes place in building. Custom has prescribed certain tools and materials; but if a specialist introduces any new process or material much anger is expressed if the work is subtle to him. As a matter of fact, it is difficult to find a dividing line between trades in these days. Progression makes it impossible to define any line of sharp definition. Materials used, or thickness of stuff, or limits of size of iron pipes, cannot be made the basis of marking off one tradesman from another. There seems only one remedy, and that is mutual agreement between the trades. The employer also, by deciding which workman to employ on a particular work, has it in his own hands to make special terms and rates.

In the decorative branches of craftsmanship the architect is deprived of a good deal of his own work; he is confronted with a host of designers of furniture and decoration which properly belong to him. The sculptor or modeller was once united to the architect, so was the decorative artist; now all these alliances have been broken, and distinct men practise them. Real progress has been retarded by this division, and there is much overlap. The decorator is invited to make a scheme of decoration quite independently of the design of the building, which disagrees with the architect's labour. We have even heard of the design being altered to suit the taste of an "art faience" manufacturer, and decorative joinery introduced of a style quite different to that of the building. But then it will be said that an architect is too busily engaged with building operations and other matters to undertake these artistic finishes, and that the extension of his professional duties has made it impossible for him to undertake decoration. Unhappily, this is so: hence we find the decorative part of architecture divided more and more among outside crafts. Specialisation has produced precision, but it has destroyed unity, and it is for the architect to try and recover the threads which formerly ran through his entire art, and made decoration the outcome of the structure.

#### THE MILLAIS PICTURES AT THE ROYAL ACADEMY.

THE winter exhibition just opened at the Royal Academy is a pleasing variation on the works of the Old Masters, and is, both in subject and interest, one of the strongest we have seen brought together. It was a happy thought to commemorate the genius of Millais by collecting his chief works, and the exhibition now on view is thoroughly representative of the genius and versatility of the late illustrious President of the Academy. Since Sir Joshua Reynolds and Gainsborough, no master has been so felicitous in the portrayal of feminine grace and beauty under various conditions, and like the works of those illustrious painters, Sir John Millais had the rare gift of imparting to his models a poetic charm. In the preface to the catalogue we are reminded that John Everett Millais was a native of Southampton, whither his family seems to have come originally from Jersey. When only

11 years of age he was admitted a student at the R.A., and in 1847 obtained the Gold Medal for an historical subject. A year afterwards he became associated with the Pre-Raphaelite movement, and in 1849 he exhibited "Isabella" (No. 23), a work imbued largely with this feeling of art. It is in Gallery I., and has been lent by the Corporation of Liverpool. The picture "Lorenzo and Isabella," as it is there called, illustrates the family of Isabella and their dependants at dinner, suggested from Keats's poem. There is a pre-Raphaelite drawing and feeling in the figure of the loving brother and sister where Lorenzo is offering Isabella an orange on a plate, and the quaintly-attired servant behind. The head adorned by long twisted hair down the back, the close-fitting garment, and the almost archaic lines of the faces and drawing of attendant, and the brother opposite who is trying to kick the greyhound which affectionately rests his head on Isabella's lap, have a quaintness and charm of their own, and this same character is seen in the long line of faces on both sides of the table, and the light wall hanging in the background. The colour and handling, too, illustrate the same art phase. From this period of his art career down to about 1862 we find his works tinged more or less with it. The rich colour in "Cimon and Iphigenia" (3), lent by J. H. Standen, shows brilliancy and richness of colour in the group of advancing figures, and marks the beginning of the Rossetti influence. There is also a Pre-Raphaelite minuteness and technique in the picture of a wounded officer and his wife and children (8). The drawing and grouping the playthings of the children, Noah's ark figures, are wonderfully free from conventional rules; also in the next very reposeful and beautiful subject, "The Vale of Rest" (1855), from the National Gallery of British Art: a convent garden, with two nuns, one throwing in the earth in a new-made grave, and the other seated, with sweet serenity on her face, her hands clasped in quiet thought. The green sward, the dark trees, and bell-cot standing out against a light evening sky, are painted with consummate skill and vivid reality, a crowning work of the first period. So, too, in the well-known picture, "The Rescue" (10), where a fireman is descending the stairs of a burning house, carrying three children to their mother, who kneels on the stairs to clasp them. The burning flakes which fall thickly, the red glow of the fire on the little boy's uplifted face as he is brought down, are familiar to all. Other well-known pictures in this room are "The Black Brunswicker" (1860), where an officer in this corps is about to open the door of a room; but his wife, in white satin, holds the handle, and is trying to prevent his going; a dog beside her. "The Order of Release" (25), where a Highlander with arm in a sling embraces his wife, his face on her shoulder. The sleeping child in her arms and the faithful collie are touching incidents. What shall we say, also, of the charming child studies, taken from the artist's own children, "My First Sermon" (26) and "My Second Sermon" (20), very real, and true to nature; "The Ransom" (30), "The Martyr of the Solway," "Asleep" (22), "Stitch, Stitch, Stitch!" (a wan-faced sempstress), "The Parable of the Tares," and the beautiful subject-portraits of "Stella" (6) and "Vanessa" (12).

"The Woodman's Daughter," lent by Lady Millais, illustrating a stanza of Mr. Coventry Patmore's poem, is an Early Pre-Raphaelite picture in drawing and colour. Next to it, "The Minuet" (34), a delightful figure of a little girl in red dress and muslin apron, holding her skirt preparing to dance, is a well-known subject. A full-length painting of a lady in Eastern robe, representing Esther in her royal apparel in the inner court of the king's house, is very refined in

colour. One of the finest of this master's Pre-Raphaelite pictures is "Christ in the House of His Parents" (57) or "The Carpenter's Shop," painted in 1850, and lent by F. A. Beer. The scene is the carpenter's workshop, familiar to many connoisseurs. The Virgin kneels beside the child Christ, who has torn His hand on a nail. St. Joseph bends over the bench, turns the hand back to show the wound, and St. John, a lad, brings a bowl of water. St. Anne, on the other side, looks at the hand. The execution of this fine interior combines all the higher qualities of the school—minute drawing and arrangement and intensity of reverential feeling. The "Proscribed Royalist," an incident of 1651, painted in 1853, is well-known and popular from engravings. Time has done little to rob it of its beauty. One of the more remarkable works of this painter is "Sir Isumbras at the Ford" (1857), lent by M. R. H. Benson. The composition represents an aged knight in golden armour crossing a river, with his helmet slung at his side, on a black horse, holding a little girl in front, and a little boy behind with a bundle of sticks. The idea is taken from an ancient romance. Everyone is familiar with the popularised subject "The Huguenot" (1852), lent by T. H. Miller, representing a young man refusing to wear the Roman Catholic badge which a lady in black is endeavouring to tie round his arm on St. Bartholomew's Day—one of the familiar figure-subjects which have been reproduced in many forms. Here we see, too, Millais's "Escape of a Heretic," dated 1857—a Spanish lover disguised as a monk rescuing his mistress, already robed for the *auto-da-fé*—a clever piece of painting; also some charming figure-subjects, "The Gambler's Wife" (54), "A Widow's Mite" (39). There is a strong resemblance between the faces of these two. The charming subject, "Autumn Leaves," a group of four girls round a burning heap of dead leaves; "Pomona," a little girl in white dress and mob cap and blue sash, holding a red apple in an orchard—a beautiful study of childhood; also a little girl holding the flower of a Speedwell, which gives its name to the picture (43). "The Blind Girl" (56), with a child sitting on the edge of a sunlit meadow, with rainbow in the sky, is another well-known picture, lent by the corporation of Birmingham. The small Pre-Raphaelite subject from Tennyson's verse is delightful in technique: "Mariana in the Moated Grange" represents the lady standing before a blazoned casement with her embroidery frame. The rich sapphire blue of her velvet dress is set off by a jewelled waist-belt; the rich colour and accessories are in keeping with the Mediaeval sentiment.

In the large gallery we meet with several important pictures, many of them familiar through former exhibitions. Lord Armstrong's "Jephthah" (98), the incident recorded in Judges xi. 35, where he is seated in a chair, his head bowed down; the charming group of figures in "An Idyll," the noble group of firs against a light sky (103), and the much-admired picture of "Chill October" in Lord Armstrong's collection; the corporation of Manchester's landscape, "A Flood," showing flooded meadow and a floating cradle with child, and a black cat, are delightful examples. If proof were wanted of Millais' skill in landscape, we have it in the beautiful view of a marshy waste, "Murthly Moss," painted in 1887, with its delicacy of drawing and colour and tufts of reeds, and in the "Dew-Drenched Furze," lent by Mrs. Sandars. Of subject pictures, we may briefly notice "Speak! Speak!" exhibited at the Academy in 1895, now in the National Gallery of British Art, in which a beautiful white-clad spectral figure of a lady startles an awakened man; "A Yeoman of the Guard" (1876); "Yes!" a lady in evening dress speaking to a gentleman in travelling



VIEW FROM THE PLATZL, KGL. HOFBRÄUHAUS, MUNICH.

MESSRS. HEILMANN AND LITTMANN, *Architects.*

dress in the portico of a house; "Rosalind and Celia" (102), and the well-remembered subject "The North-West Passage" (1874), an interior where an old sailor is describing to a girl in white dress, who sits at his feet, his arctic journey; and the dark and weird picture illustrating Keats's "The Eve of St. Agnes," painted in 1863, now in the possession of Val. C. Prinsep, R.A. The beautiful portrait studies of "Lady Peggy Primrose," a fair-haired child, the pretty group of children in 107; portrait of "Nina" (111), a fair-haired little girl seated on a green earthenware pedestal in white and bluish-greens, with a tired look in her eyes; the stately portrait of Mrs. Bischoffsheim (113), the portrait of John Bright, of Mrs. Caird (115), of J. C. Hook, R.A., of H.R.H. the Princess Marie of Edinburgh, now the Crown Princess of Roumania (120) are worthy of this master of portraiture. The delightful idealised studies, "For the Squire," "Sweetest Eyes, &c." (118), "Forget-Me-Not," "The Nest," "Cuckoo," are extremely sweet studies of children, full of life and beauty, as only this master of character and expression can depict—perfectly natural, yet imbued with a grace that takes them out of the commonplace. Gallery IV. has one or two large landscapes. "The Fringe of the Moor" (147) has a sunny open-air effect, "Lingering Autumn," and the well-known picture, "Princess Elizabeth in Prison," with the elaborate Elizabethan oak cupboard behind (148); "The Ruling Passion," lent by Lady Millais; the popular "Bubbles," "Puss in Boots," "Cherry Ripe" (169), "New Laid Eggs," and other studies of girlhood. The other galleries and the water-

colour room are full of pictures and studies representing every period of this great painter's industrious career, and worth the study of every admirer of painting.

THE TAXATION OF LAND VALUES.

A CONFERENCE was held in Bradford on Tuesday on the subject of the taxation of land values, at which delegates were present from all parts of Great Britain. Mr. W. P. Byles, who was in the chair, said that the time was ripe for the taxation of land values. Scotland had led the way. It had converted the great municipality of Glasgow. They in Scotland had secured the support of 62 Scotch assessing authorities, and had moved Parliament in the matter. Wales had done likewise, and everyone knew Ireland's appreciation of the blessings of the land monopoly.

A discussion followed on a resolution to the effect that the true basis of national and local taxation was not labour and the product of labour, but the value of land due to the activities and necessities of people.

Mr. Isherwood (Bury) moved as an amendment that land, whether occupied or not, should be taxed for all purposes at the full actual value from time to time, and delegates from Gateshead Union supported this.

Dr. Clark, M.P., said they should firmly express the opinion that they should change the taxes on labour and products of labour to taxes on land values which would be sufficient for all local and Imperial purposes.

Mr. R. McGhee, M.P., contended that legislation in that direction would set free the true sources of production to those willing to produce. He believed this would solve the labour problem.

The resolution was carried with ten dissentients. Mr. E. Adams (Edinburgh) proposed a resolution demanding separate valuation of land apart from

improvements and assessment of taxes on the full true annual value of land, whether used or held idle. This was carried unanimously, and a long discussion took place on a proposal not to vote for Parliamentary candidates who did not pledge themselves to the principle of the taxation of land values. The resolution was lost by 35 votes to 33. Another resolution passed demanded the power for local assessing bodies in Britain to rate the value of land for local purposes.

ACADEMY ARCHITECTURE, 1897.

THE second volume of Mr. Alex Koch's annual architectural review was published just before Christmas,\* and by the courtesy of the editor we are enabled to-day to present our readers with three typical illustrations, chosen from the foreign works therein represented among the works of the year. All the reproductions are extremely well done, and are printed on highly glazed paper in excellent style, so that although in many instances the reductions have necessarily been considerable, the results are highly satisfactory and clearly executed. The book contains a goodly number of drawings shown at the Royal Academy in 1897, but which could only be borrowed for photographing after the close of the exhibition in August. Among the English contributors we may mention the following well-known architects:—Messrs. Aston Webb, Ernest George, E. W. Mountford, Maurice B. Adams, John Belcher, W. D. Caröe, G. H. Fellowes-Prynne, among others. A comprehensive choice of the best things done during the year are thus brought together in the two volumes produced by Mr. Koch, and are thus preserved in a very handy form for reference. The scale of the plates in so compact a

\* Academy Architecture and Architectural Review, 1897. Vol. XII. Edited by ALEX KOCH, Architect. London: 58, Theobald's-road, W.C. 4s. net.

folio is, of course, much smaller than the reproductions which we are enabled to give from time to time from the same subjects; but the advantage of collecting the drawings thus together is patent to anyone. Added to the drawings of architecture are some photographs of sculpture from the Academy and the Royal Scottish Academy Exhibitions, as well as from Berlin. Among these last is an exquisite statue by Mr. Walter Schott, of Berlin, representing a "Girl Playing at Ball." The same artist had a nude rendering of the same figure in the same exhibition, which was excellent; but we think, on the whole, preference will be accorded to the draped figure, which we herewith illustrate. The principal staircase from the Kgl. Hofbräuhaus, Munich, is shown by a clever line drawing by the architects, Messrs. Heilmann and Littmann, whose work in some ways is quite Mediaeval in the spirit of its design. This is noticeable also in the exterior view of the same building as seen from the Platzl, which we also print with these notes. We cannot admire much of the modern Continental work; but Dr. P. J. H. Cuyper's churches present an excellence all their own. Illustrations are given of his Church of the Sacred Heart at Tilburg, and St. Jacobus, St. Gravenhage, two notable instances of his brick buildings. The Exhibition buildings at Stockholm, by Mr. Gustaf Wickman, are among the plates of interest; and the Town-hall, La Plata, by Professor Hubert Stier, of Hanover, may be named for its scale and importance. A model of the same architect's design for a Provincial Museum in Hanover is likewise illustrated. The curious extravagances of modern German taste is represented by the interior of the Restaurant "Zum Heidelberger" Central Hotel, Berlin, by Mr. Wilhelm Walther, architect, who has done a picturesque and extensive group of buildings—the Schloss Freund Kurfürstendam, Berlin.

#### EFFECT OF SEA-WATER ON CAST IRON.

IT may not be generally known that under certain conditions cast iron will resist the corrosive action of combined oxygen and water, or of carbonic acid and water, better than either wrought iron or rolled steel. This comparative immunity of cast iron to deterioration relatively to the two other forms or varieties of the same material, only obtains so long as when emerging from the loam of the foundry, or from the jaws of the rolling-mill, the natural surface of each description of metal is kept intact. If the "skin," as it is termed, be once broken, the relations between the three are reversed, and the cast iron corrodes with much greater rapidity than the two others. This difference becomes very considerably accentuated if all the surfaces be planed or sheared, or treated in any manner which would impart to them a bright polished appearance. It is a little curious that similarly to certain kinds of timber, cast iron corrodes more quickly when exposed to successive alternations of humidity and acidity, or when, as frequently occurs, there is but a thin layer or *couche* of moisture on its surface. If plunged deep down in either salt or fresh water, it will last a good deal longer. That this breaking of the skin is not a mere fanciful idea, was abundantly demonstrated by the experiments undertaken some years ago upon the fracture of cast-iron bars. A very slight application of the chisel or the file, although the result was little more than a mere scratch, was sufficient to break the skin of the iron, and very appreciably diminish its powers of resistance. It can be readily understood, arguing analogically, that the skin, acting as a protection to the material, once being removed, either partially or *in toto*, the way is cleared for the deleterious influence of salt water, or of any other corrosive agent.

The question of time has a very intimate and important bearing upon our subject, and though no doubt some valuable information has been obtained with respect to the behaviour of cast iron after long immersion in sea-water, yet it is by no means of an altogether satisfactory or conclusive character. It should be borne in mind that the composition—that is, the particular quality of the metal—very materially restricts or prolongs its durability in salt water. It is, therefore, no absolutely conclusive test of the resistance of cast iron to the deteriorating action of the sea, that some specimens in the form of piles, columns, and other component parts of cast-iron piers and jetties built in salt, or even fresh, water have not lasted as long as they might have been

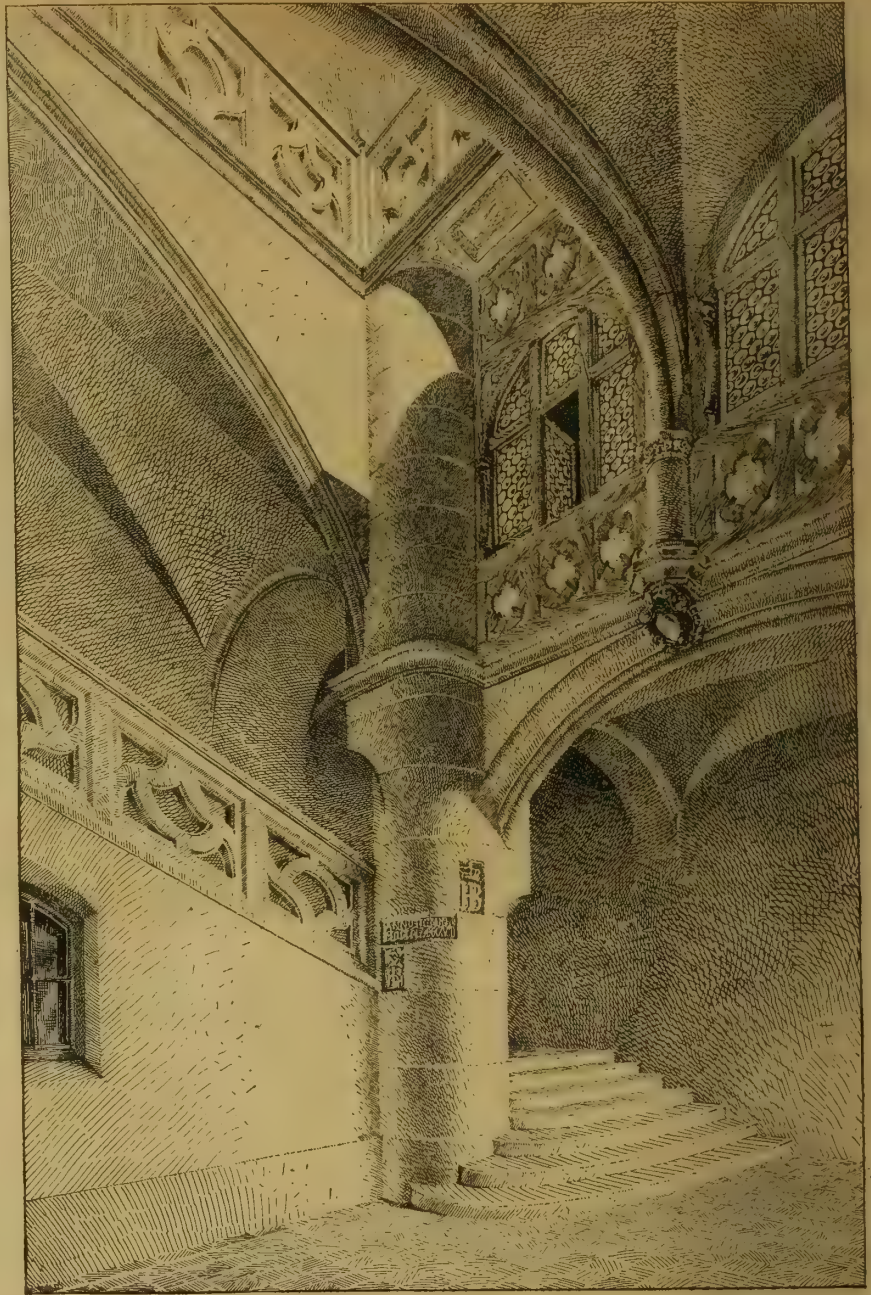

PRINCIPAL STAIRCASE, KGL. HOFBRÄUHAUS, MUNICH.

MESSRS. HEILMANN AND LITTMANN, Architects.

expected to do. Compared with other examples, which have survived under the same circumstances ever since they were first immersed, the reason for the superior longevity of the latter is that the quality or description of material was better adapted for the purpose. The same facts hold good for steel, for experience has shown that manganiferous steel is much more corroded by the influence of sea-water than when the percentage of that ingredient is almost inappreciable.

Some further light has been thrown on this interesting question by some analyses conducted in the laboratory of the French Government at Brest upon specimens of cast iron, which have rested long enough at the bottom of the sea to afford excellent data for a full consideration of the whole matter. The specimens investigated were cast-iron shells which had laid in the harbour of Brest for a period ranging from 100 to 150 years. Outwardly there was little or nothing to indicate that any material change had taken place in their molecular or chemical constitution, except that their weight was manifestly much less than it would have been for the same volume of a similarly new projectile. That searching and unimpeachable agent, analysis, revealed, however, after a brief examination, that the metal, although not so completely changed as to be unrecognisable for what it really was, had undergone many and serious modifications. All

its usual physical properties had disappeared. It no longer possessed any tenacity, cohesion, elasticity, or hardness, and was clearly utterly worthless for the future as a missile of warfare. When submitted to the microscope, a section of the old shells presented a loose and rather fragile kind of texture, full of holes surrounded by a greenish tint, a sure indication of a very rapid and decided oxidation of the metal. Chemically speaking, there had been a considerable reduction in iron and a corresponding increase of carbon, the latter replacing as it were the former. Since the specific gravity of cast iron may be taken on the average at 7.55, and that of carbon at 3.52, the loss of weight is at once explained. No doubt the same causes which brought about the alteration in the material of the shells are equally actively at work in other cast-iron work placed under similar conditions; but it must be borne in mind that the quality of the metal used in casting shells a century and a half ago was not of a very high class. Having regard to the excellent quality now employed, suitable for every description of purpose, and varied accordingly, we should not be justified in assuming that the fate of the shells will befall our cast-iron structures erected in sea-water. T. C.

A new organ is being erected in the parish church of St. Peter, Salterton, near Exmouth.





GIRL PLAYING AT BALL, BERLIN EXHIBITION, 1897.

MR. WALTER SCHOTT, Sculptor.

**SANITARY INSPECTORS' ASSOCIATION.**

SIR JOHN HUTTON (the president) delivered his New Year's address to members of this association on Saturday at Carpenters' Hall. He said it had long been the wish of those interested in the association to form a fund from which members could be encouraged in their studies and researches in the interest of the public health. A practical proposal had now been made by one of their members to found a Chadwick and Richardson memorial fund. This offer was a contribution of 50 guineas, provided that, within nine months, the fund were raised to 500 guineas. The competitions for prizes would be held yearly in such form as might be deemed best, either by having special competitions, or for the best papers read at London or any of the branch meetings. To promote longevity was an aim and result of the work of the sanitary inspector. In 1660 the rate of mortality in London was 80 per 1,000 per annum, but the death-rate in the county of London in 1896 was only 18.9. Many contributory causes must have operated in producing this result, not the least of which he claimed, in recent years, to be the zealous labour of the sanitary inspector. The present death-rate of 18.9 per

1,000, light as it was, could be still further reduced. Cleanliness was an immense factor in all practical sanitary work. Filth was the parent of disease, both among individuals and communities. The question of the purity of the water supply to London would, he hoped, secure the early attention of thoughtful people. Referring to the numerical strength of the association, he said that at present it had 670 members, including 52 honorary members and 26 associates. On the motion of Mr. T. G. Dee (chairman of the council), seconded by Mr. W. W. West, a vote of thanks was accorded to Sir John Hutton for his address.

At Beddington Corner, Mitcham, on Saturday, Jan. 1 the foundation-stone of an isolation hospital for the Croydon Rural District Council was laid. The buildings will comprise an entrance lodge, administrative block with accommodation for doctor, matron, nine nurses, and six servants; three ward blocks with accommodation for twenty-eight patients, mortuary, discharging-room, and stables; laundry and disinfecting block. The architects are Messrs. R. M. Chart and Son, of Union Bank Chambers, Croydon; and the contractors are Messrs. D. Stewart and Sons, of Walsington, the amount of their contract being £15,878.

**OBITUARY.**

MR. CHARLES KING BEDELLS, F.S.I., of Toft Lawn, Hornsey-lane, and 1, John-street, Bedford-row, died very suddenly on Friday last, aged 66 years. It appears that he had just completed the survey of a house with his son, Mr. C. Herbert Bedells, and was about to leave. Mr. Herbert Bedells went forward to open the door, when his father was attacked by syncope, and fell down the stairs; when picked up, life was found to be extinct. Deceased was the senior partner in the firm of Lander and Bedells, land surveyors, and had an extensive practice; he was well known as an authority on questions of easements and party-walls. He had been a Fellow of the Surveyors' Institution since January, 1879, and for many years past had been one of the senior deacons at Park Congregational Chapel at Crouch End, of which the Rev. Alfred Rowlands, LL.B., is pastor. The funeral services were held in that chapel on Wednesday afternoon, and were very largely attended.

**CHIPS.**

Messrs. Ashwell and Nesbit, Limited, have sent us one of their useful and well-designed date-cards, which will doubtless find a place on many office walls.

The additions to the Infectious Diseases Hospital, Morton Banks, Keighley, are being warmed and ventilated by means of Shorland's double-fronted patent Manchester stoves with descending smoke-flues, and Shorland's patent Manchester grates, the same being supplied by Messrs. E. H. Shorland and Brother, of Manchester.

The Jews of the East-end of London have presented his portrait to Sir G. Faudel-Philips, as a recognition of the manner in which he had discharged the duties of Lord Mayor of the City during the past year. The portrait was painted by Mr. Solomon J. Solomon, A.R.A.

Mr. George B. Post is the designer of the plans approved and adopted for the College of the City of New York, and has been appointed architect of the building by the Board of Trustees. Plans for the building, which, it is estimated, will cost 500,000dol., were requested from eight architects, and each is to receive 350dol., except the one chosen to execute the work.

The National Gallery has purchased from Messrs. S. T. Smith and Son, of Duke-street, a "Portrait of the Artist at the age of 18," by Mlle. Vigée, afterwards Mme. Vigée-Lebrun. The picture will not be on view for a short time.

On Saturday the new public hall at Cambuslang was opened with an art and industrial exhibition. The premises include a library and reading-rooms, recreation-rooms, and public hall, and have involved a total outlay of £5,000. The public hall is 76ft. in length, 40ft. wide, and 30ft. high, and lavatories, and cloak and retiring rooms are provided.

The annual report of the Queensland Railway Commissioners covers the operations of 2,389 miles of line, an increase of 116½ miles for the past year. The capital was increased during 1897 by £1,514,480 and the railway fund now amounts to £20,398,632.

The parish church of Kilwinning, which has been closed for some time, owing to extensive alterations and repairs and the introduction of a new organ, was reopened for worship on Sunday.

Mr. Richard Garnell, of 21, Belmont-avenue West, Belfast, sends us some specimens of a new detective envelope which he is introducing, and which certainly more effectually checkmates inquisitive and dishonest people than any other contrivance of the sort we remember. It is very simple, but well worth the attention of business firms sending away small sums by post, and by others who prefer that their private correspondence should remain private. The ordinary appearance of the envelope is not altered, and it is not troublesome to open, as are some of the similar efforts that we remember have taxed our patience in the past.

At North Leigh Free Church, on Friday, a tablet and medallion to the memory of the late Rev. Dr. Robert Macdonald (1813-93) was unveiled by Lady Grainger Stewart, a daughter of the deceased. The sunk portion of the tablet is of white marble, while the outer bordering is of Sicilian marble. The medallion is placed in the centre of the tablet in profile, and is life-size. The style of the tablet is Early English Gothic. Underneath the tablet is a brass plate bearing an inscription. The medallion was executed by Mr. D. W. Stevenson, R.S.A. A new organ has been built in the church by Messrs. William Hill and Son, London. The lower part of the organ-case, which is of stained yellow pine, is in panelling, and the upper portion is in open wood-work, with mouldings and tracery. The cost of the organ is about £1,250.

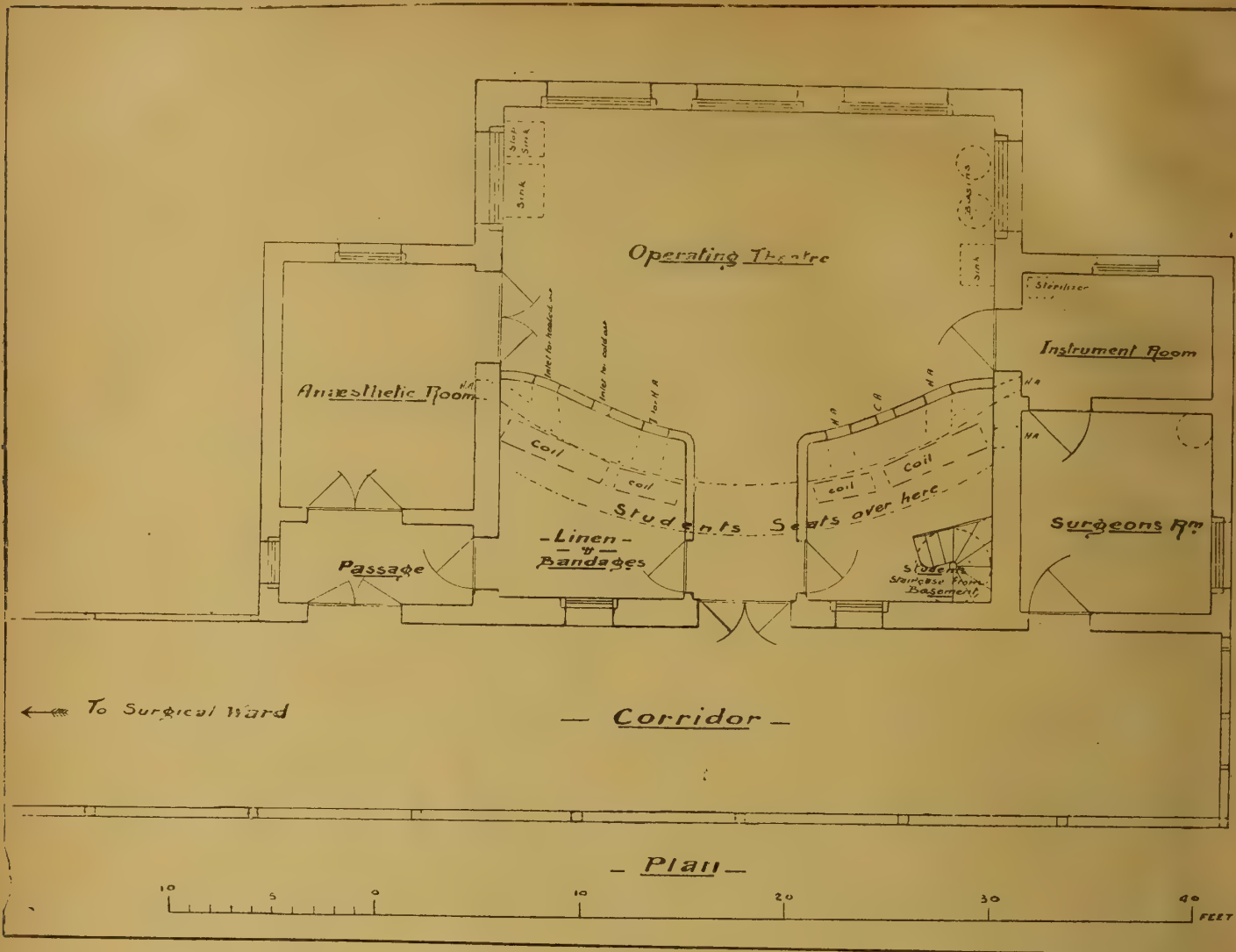

### NEW OPERATING THEATRE, DUNEDIN, NEW ZEALAND.

THE hospital trustees some time back decided to build a new operating theatre, and instructed their architects to prepare plans and specifications, with all the latest up-to-date improvements. It has now been completed and publicly opened, and the trustees are sanguine that it will give satisfaction to the honorary medical staff, and will prove a lasting boon to the patients. The building is placed near the surgical wing, and on the same level, the floor being 7ft. from the ground, and the whole area built over and 4ft. all round the building is asphalted. It is connected to the surgical wards by a corridor 9ft. wide, and constructed with brick on concrete foundations, and Port Chalmers stone base. The operating-room is 24ft. by 24ft., and has a gallery capable of accommodating about sixty students. There are an anæsthetic room 12ft. by 9ft. 6in., an instrument-room 9ft. 6in. by 6ft., a surgeons' room 10ft. by 9ft. 6in., and a room for holding bandages and dressings. The patients are first taken into the anæsthetic room, and thence to the theatre; there is a second doorway leading out of the theatre, by which the patients may be removed after operation. The floor of the theatre and instrument room is laid with marble mosaic or terrazzo on concrete, and polished. The walls of the theatre, 7ft. high and 4ft. in the instrument-room, are lined with opaline in large sheets, with as few joints as possible, and all angles throughout are rounded. The remainder of the walls are finished with Keene's cement, polished and painted and varnished. The opaline has a beautiful surface, and was specially imported. The students' gallery is entered from the basement. It is constructed entirely of concrete and finished in cement, and polished perfectly smooth, so that the whole theatre may be washed down with a hose, and either hot or cold water may be used for this purpose. The roof of the building is of slate, and the theatre roof is of the Mansard type, with double sashes

on all sides, with green blinds fitted between the sashes, so that the light may be regulated. There are also five large windows, with fanlights fitted to open, glazed with ground plate-glass, which has a softening effect on the light, and also prevents any person seeing into the theatre from outside. The fittings are of the latest design, being imported for the purpose. In the theatre there are two sponge sinks, a slop sink, and two basins. There is also a basin in the surveyor's room. The supply and waste taps of the basins and sinks are all worked with treadle action instead of the ordinary method, this being done in order to prevent any risk of the fittings being soiled by the hands. A "Pasteur" filter has been fitted in the cistern over the instrument-room to supply filtered water for operations. In the instrument-room there is a steriliser fitted with a gas-heater. The heating-apparatus is fitted under the students' gallery. The cold air passing over the steam coils enters the theatre through louvred ventilators, so that the amount of air entering the theatre may be regulated. There is also provision made for admitting cold air direct into the theatre should it be necessary. The air is extracted from the centre of the ceiling by a galvanised iron shaft fitted with a steam coil to increase its extracting power. The lighting is at present by gas; but it is contemplated at some future date that the whole of the hospital will be lit by electricity, the motive power being obtained from the present boiler, which was provided about three years ago for supplying steam for heating and other purposes. The plumbing work was intrusted to Messrs. Corbett and Co., and has been done in a thoroughly workmanlike manner. Mr. George Morrison was the contractor for the building, the whole being designed and carried out by Messrs. Mason and Wales, architects.

The erection of the new dead meat market and abattoir, which the Leeds Corporation are about to provide, will shortly be commenced.

### LORD LEIGHTON MEMORIAL, CAMBERWELL.

SIR EDWARD J. POYNTER, President of the Royal Academy of Arts, opened this group of buildings last evening, and dedicated the Arts and Crafts Institute to the memory of Lord Leighton, P.R.A., who was the first President of the South London Art Galleries. We published a view of the new building, which has been erected by the Vestry of Camberwell, from the designs of Mr. Maurice B. Adams, F.R.I.B.A., in the *Building News* for April 10, 1896, and a detail of the façade appeared in our issue for July 31 same year. It has been the munificent gift to the parish by Mr. J. Passmore Edwards, and occupies a fine site in the Peckham-road. The buildings, set back in a line with the adjoining houses and the forecourt lawns, have been inclosed with richly-treated ornamental wrought-iron railings and gates in keeping with the façade. The leading feature of the front is formed by the boldly projecting porch entrance to the South London Art Galleries, which are situate at the rear of the Technical Institute. A spacious hall corridor leads straight through into the big gallery, and the oak-pedimented doorway between the two buildings is fitted, like all the other doorways in the picture galleries, with fireproof folding doors.

The Institute comprises four large studios, and also the workshops for craft work, which are located in the half basement. A commodious committee-room or office is on the ground floor for the curator and art director. Retiring rooms, cloakrooms, lavatories, &c., are provided for the students, including a lunch-room for lady pupils on the mezzanine floor. A residence is provided on the premises for the caretaker and porter. A fine north light is obtained at the rear by means of very large studio windows, and these on the top floor extend well into the roof. Model rooms are furnished in the main studios with lavatories and w.c.'s to each. The big studios are 18ft. high, and in the modelling studio a gallery

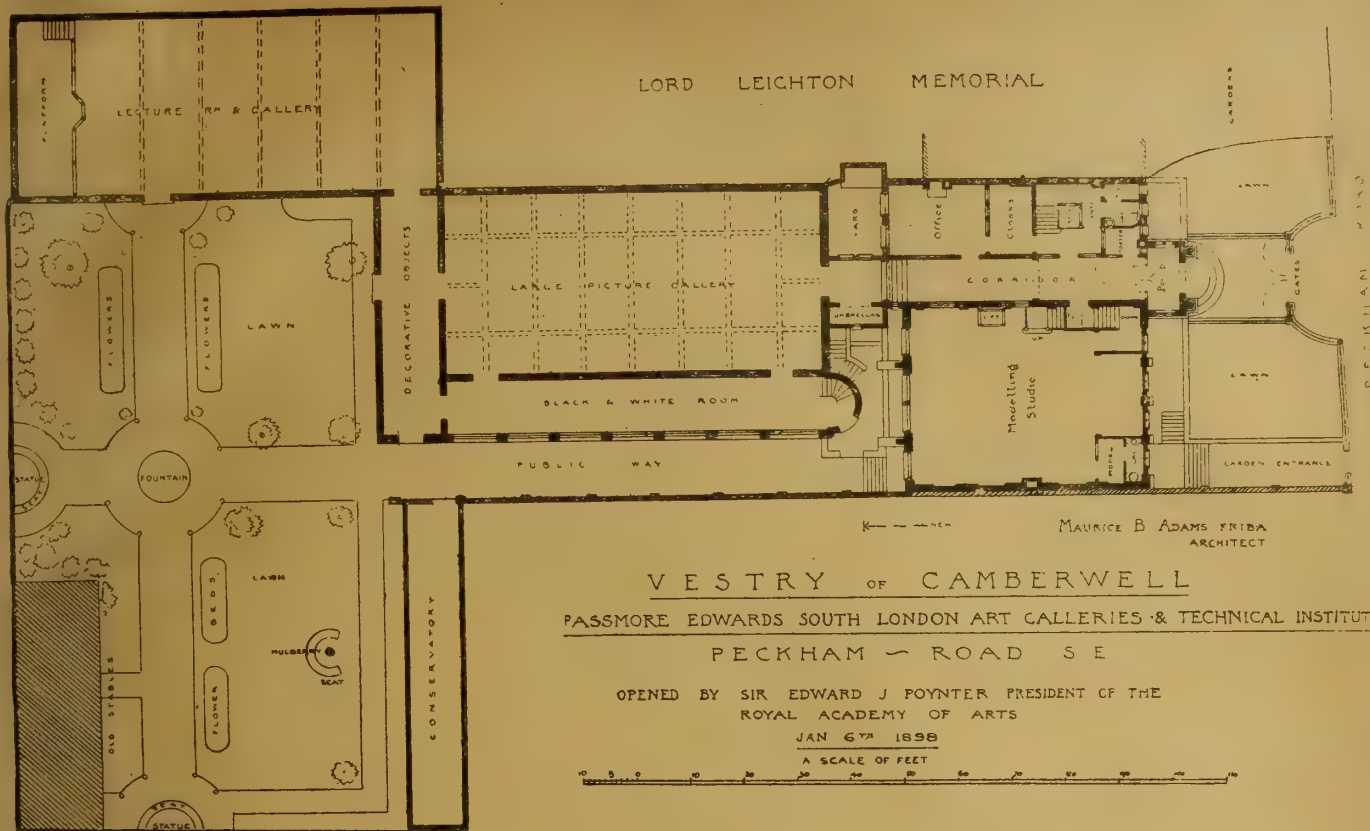

extends along the south side. A through way is contrived below the ground-floor level as an approach to the public gardens at the back and for the purpose of bringing in works of art intended for exhibition in the picture galleries or for the use of the Technical Institute. A lift by Messrs. Archibald Smith and Stevens is provided from the basement to the top floor. The staircase and floors are constructed in Fawcett's fireproof steel and concrete work. Wood-block pitch-pine flooring is used for all the rooms, and encaustic antique tiles are laid in the entrance porch and corridor. The building is executed in Portland stone and Lawrence's red-brick facings, the spaces between the ground floor arcade being built with patent salt-glazed red bricks, made by Messrs. Cliff and Son. The style of the building is Renaissance, richly treated with carvings by Mr. W. Goscombe John, who also executed the sculptured pediment which contains life-size figures representing "Architecture," "Sculpture," and "Painting." The flock wall-papers, by Messrs. Jeffrey and Co., and the decorations of the galleries were executed in accordance with suggestions by Sir E. Burne Jones, Bart., and Sir Wyke Bayliss, P.R.B.A. The parquet flooring has been completed from the cartoon of Mr. Walter Crane, who designed the entire floor of the large gallery. The central panel is inlaid with the legend, "The Source of Art is in the Life of the People." The bronze memorial cartouche over the principal entrance was executed by Mr. W. Goscombe John. Mr. Nathaniel Hitch, the sculptor, did the red Belgian marble tablet in the hall. It is about 8ft. high, and is enriched by a sculpture, in the upper part, of St. Giles, the parochial saint of Camberwell. Mr. H. W. Hogan has acted as clerk of the works. The builder was Mr. Richardson. The work now done has included the re-roofing of the big gallery and repair of the old buildings, as well as their decoration, executed by the workmen employed by the Works Department of the Vestry. The gardens have been laid out from the plan of the architect. Mr. Cecil Burns is the art master, acting under the direction of the Education Board of the London County Council, of which Mr. Geo. Frampton, A.R.A., and Mr. W. R. Lethaby are the Art Directors. A splendid collection of paintings and works of art is on view in the galleries, including a portrait of Mr. J. Passmore Edwards painted by Mr. G. F. Watts, R.A., and some original drawings presented by their author, Mr. Ruskin; the late Mr. Wm. Morris's furniture, painted by Sir E. Burne-Jones, is also on view.

**COMPETITIONS.**

**BIRMINGHAM.**—A meeting of the Lunatic Asylum Committee was held on Monday at the Council House. The chief business was the consideration of the appointment of an assessor to advise the committee on the competitive plans sent in for the new asylum which is to be erected at Northfield. After some deliberation, the committee decided to appoint Mr. George T. Hine, F.R.I.B.A., of Parliament-street, Westminster, who is frequently employed as assessor by the Lunacy Commissioners.

**NOTTINGHAM.**—The Public Parks Committee has confirmed the report of the assessors appointed in the New Cemetery Competition, and have awarded the premiums as follows:—(A) Landscape gardening, &c.: 1st, Mr. Thomas W. Mawson, Windermere; 2nd, Messrs. Wm. Barron and Son, Borrowash, Derby. (B) Chapels, lodges, &c.: 1st, Messrs. Arthur E. McKewan, A.R.I.B.A., and Alfred J. Dunn, A.R.I.B.A., Colmore Chambers, Birmingham; 2nd, Messrs. Chas. A. Nicholson, M.A., and Hubert C. Corlette, A.R.I.B.A., Gray's Inn, London. The drawings received will be on view to the competitors and members of the city council at the Guildhall, Burton-street, Nottingham, to-day (Friday).

**POSTER DESIGN.**—In connection with the Art Metal Exhibition, to be held at the Royal Aquarium, London, in May and June next, designs for a double-crown poster are invited. All designs must be sent in carriage-paid, on or before February 28, 1898. They must be addressed to "Art Metal Exhibition, Poster Competition, Mr. Edgar S. Shrubsole, Royal Aquarium, London." Each design should bear a distinguishing mark or motto on the margin, and must be accompanied by a sealed envelope bearing outside a similar distinguishing mark or motto, and inside the full name and address of the designer. These envelopes will not be opened until after the judges have made their awards. The judges will be chosen from the council of the exhibition, and their decision shall be final and absolutely binding on the competitors. The designs sent in will be placed on view in the Royal Aquarium in March, 1898, and also during the exhibition, and they shall be the property and copyright of the Royal Aquarium Society. Ten guineas will be paid by the Royal Aquarium and Summer and Winter Garden Society, Limited, for the design selected by the judges as the best. Any competitor may send in any number of designs, but each one must be sent separately, and must bear a different distinguishing mark or

motto. All designs must be full size—viz., 30in. by 20in.; the lettering to be embodied is: "Art Metal Exhibition, Royal Aquarium, London, May—June, 1898." A blank space must be left at the bottom of the poster not less than 2in. in depth; this space is for the purpose of announcing different railway arrangements, &c. It will be permissible to introduce a figure in the design if the competitor think fit. Each design must be drawn on stout paper, and be either mounted on a stiff cardboard, or be backed by linen and mounted on a wooden-framed strainer, a margin in any case to show all round the drawing.

**SOLDIERS' AND SAILORS' MONUMENT.**—The United States National Sculpture Society, having been called in to judge the designs submitted for the Soldiers' and Sailors' Monument of Hudson County, New Jersey, has made, through the committee appointed to examine the models, a report, which places first the design by Philip Martiny, sculptor, and Ackerman and Ross, architects, and recommends its adoption. The second place is awarded to the design by Charles H. Niehaus, sculptor, and Henry Bacon, architect; and the third to that by J. Massey Rhind, sculptor, and Arthur D. Pickering, architect. Thirty-nine designs were offered in competition, and the committee speaks highly of their general excellence and interest.

**SOUTHEND-ON-SEA.**—In the competition for a district church of St. Alban at Southend, Essex, the assessor, Sir Arthur W. Blomfield, A.R.A., has placed the design submitted by Messrs. Nicholson and Corlette, of 28, Theobald's-road, W.C., first. The selected architect will proceed with the work as speedily as possible.

The Natal Government have appointed Mr. M. W. Carr, M.Inst.C.E., to the office of consulting engineer to the Agent-General for the colony in London.

The lengths of the railways open for traffic in Western Australia at the end of June, 1897, were as follows, viz.:—Eastern Railway—Freemantle to Kalgoorlie—including Perth Racecourse, Newcastle and Beverley branches, and Mahogany Creek deviation—453 miles; South-Western Railway, including Canning Racecourse, Donybrook, and Busselton branches—165 miles; Great Southern Railway—Beverley to Albany Jetty—243 miles; Northern Railway—including Walkaway and Mallewa branches—109 miles; total mileage, 970 miles. Increased mileage during the year, 382; twenty miles of double line and 950 miles single line.

## TO CORRESPONDENTS.

[We do not hold ourselves responsible for the opinions of our correspondents. All communications should be drawn up as briefly as possible, as there are many claimants upon the space allotted to correspondents.]

It is particularly requested that all drawings and all communications respecting illustrations or literary matter should be addressed to the EDITOR of the BUILDING NEWS, 332, Strand, W.C., and not to members of the staff by name. Delay is not infrequently otherwise caused. All drawings and other communications are sent at contributors' risks, and the Editor will not undertake to pay for, or be liable for, unsought contributions.

Cheques and Post-office Orders to be made payable to THE STRAND NEWSPAPER COMPANY, LIMITED.

## TERMS OF SUBSCRIPTION.

One Pound per annum (post free) to any part of the United Kingdom; for Canada, Nova Scotia, and the United States, £1 6s. 0d. (or 6dols. 30c. gold). To France or Belgium, £1 6s. 0d. (or 33fr. 30c.). To India, £1 6s. 0d. To any of the Australian Colonies or New Zealand, to the Cape, the West Indies, or Natal, £1 6s. 0d.

## ADVERTISEMENT CHARGES.

The charge for Competition and Contract Advertisements, Public Companies, and all official advertisements is 1s. per line of Eight words, the first line counting as two, the minimum charge being 5s. for four lines.

The charge for Auctions, Land Sales, and Miscellaneous and Trade Advertisements (except Situation advertisements) is 6d. per line of Eight words (the first line counting as two), the minimum charge being 4s. 6d. for 40 words. Special terms for series of more than six insertions can be ascertained on application to the Publisher.

Front-page Advertisements 2s. per line, and Paragraph Advertisements 1s. per line. No Front-page or Paragraph Advertisement inserted for less than 5s.

Advertisements for the current week must reach the office not later than 3 p.m. on Thursday. Front-page Advertisements and alterations in serial advertisements must reach the office by Tuesday morning to secure insertion.

## SITUATIONS.

The charge for advertisements for "Situations Vacant" or "Situations Wanted" is ONE SHILLING FOR TWENTY-FOUR WORDS, and Sixpence for every eight words after. All Situation Advertisements must be prepaid.

## NOTICE.

Bound copies of Vol. LXXII. are now ready, and should be ordered early (price Twelve Shillings each), as only a limited number are done up. A few bound volumes of Vols. XXXIX., XL., XLI., XLVI., XLIX., LI., LII., LVIII., LIX., LXI., LXII., LXIII., LXIV., LXV., LXVI., LXVII., LXVIII., LXIX., LXX., LXXI., LXXII. may still be had, price Twelve Shillings; all the other bound volumes are out of print. Most of the back numbers of former volumes are, however, to be had singly. Subscribers requiring any back numbers to complete volume just ended should order at once, as many of them soon run out of print.

RECEIVED.—S. N. D.—W. P.—F. V. M. (Newport).—A. S. A.—H. B. F.—H. G. T.—A. D. L.

## "BUILDING NEWS" DESIGNING CLUB.

DRAWINGS RECEIVED.—"Orb," "Tee Square," "By Go."

## Correspondence.

## WALTHAMSTOW BATHS COMPETITION.

To the Editor of the BUILDING NEWS.

SIR,—So far as I know, Messrs. Spalding and Cross, although they were paid the second premium of twenty-five guineas (not yet returned), have never exhibited any interest in the amount to be paid me by way of compensation.

I have been offered the paltry sum—under the circumstances—of £100, subject to the approval of the Local Government Board. The matter is now, I believe, under consideration by that authority.—I am, &c.,

J. WILLIAMS DUNFORD.

100c, Queen Victoria-street, E.C.

## CARDIFF COMPETITION.

SIR,—Mr. Matear deserves the thanks of his fellow-competitors, and as one of such, I confirm his objections to the selected design. I could add many more objections; but one shall suffice. The police department was ordered to be to the north of the law courts; but on the south frontage we find the main portion of this department. *En passant*, is it advisable to cut this department in two by the cell corridors?

It may interest Mr. Matear to know that the workshops for weights and measures department he fails to find are located on the second floor—surely a great mistake, and very inconvenient for access for heavy weights, scales, &c. The conditions insisted on this department being on the ground floor.

Mr. Waterhouse only occupied two or three days in adjudicating on the 56 designs. Less than half-an-hour for each design! This is a poor return for the three or four months' hard work of competitors.

To sum up, it would appear that Mr. Waterhouse has arrived at a hasty and unsatisfactory decision. If, as is probable, he put aside those he considered contravened the conditions on the question of cost, surely he ought also to have rejected those who broke the conditions in other ways.

The old-fashioned way of settling a competition would appear to be the best—i.e., give the award to the best plan and leave the onus of proving the cost to the competitor, or, on the other hand (as Mr. Waterhouse did at Birmingham when placing Mr. Lynn's design), award the premiums, and then state which is absolutely the best plan and design. Then the corporation would have the choice, and would then have an opportunity (as is denied them in this instance) of having a really good plan and design.

I would ask Mr. Waterhouse if he verified the cubical contents of each design, as is most important, as will be seen from the following instance. In a late competition my design (although admitted by the assessor to be superior to those he selected) was rejected on account of alleged excess of cost. After the competition was all over and the scheme abandoned, the borough surveyor, who made an independent calculation, discovered that the cubic contents of the design placed first was much understated, and, in fact, greater than mine!—I am, &c.,

NEMO.

## CHIPS.

Mr. E. Bailey Denton, M.Inst.C.E. (Bailey Denton, Son, and North, of Palace Chambers, Westminster), has taken Mr. G. Maxwell Lawford, Assoc.M.Inst.C.E., President of the Society of Engineers, into partnership, and the firm will henceforth be known as Messrs. Bailey Denton, Son, and Lawford.

The premises of Mr. A. J. Beaven, builder and contractor, Dear-lane, Bedington, Bristol, were destroyed by fire on Friday night. The damage is estimated at over £5,000.

Mr. H. J. Stannard, a stone merchant, who lived at Stanley Villas, Combe Down, Bath, died, on Tuesday, after a short illness at his residence. Deceased, who was over 70 years of age, had been a member of the Monkton Combe Parish Council since its first election. He was a large employer of labour.

The Manchester City Council, at a meeting on Wednesday, adopted a recommendation from the improvement committee to apply to the Local Government Board for a loan to carry out an extensive scheme of municipal lodging-houses. The project is to provide accommodation for persons displaced by extensions of the markets, and will form one of the several corporation colonies in and around the city.

The will of Mr. Henry Carpenter, of 133, Marina, St. Leonards, and formerly of Essex Villas, Kensington, architect, who died on November 13, has been proved by Mrs. Rebecca Carpenter, the widow, and Mr. Arthur Carpenter, of 11, Queen Victoria-street, the son, the executors, the value of the personal estate being £613 16s. 5d.

The hall built by Sir Oswald Mosley, Bart., at Rolleston, Burton, in commemoration of the Queen's long reign, was opened a few evenings ago. Mr. Eaton, of Derby, was the architect, and Mr. Kershaw, of Burton, the builder.

The new parochial hall and schools at St. Mary's, Bearwood, were opened on Friday by the Bishop of Lichfield. The building, which is of brick, stands contiguous to the church, and comprises a hall, with accommodation for 300 people, and two classrooms. The cost has been £1,815. The contract has been carried out by Messrs. Harley and Son, from the plans of Mr. J. H. Hawkes.

The dealings in land and property during 1897 have been of a very satisfactory character. The total amount of the sales which took place at the London Auction Mart, £5,257,723, was considerably in advance of the total of £4,476,801 for 1896. In addition, considerable transactions have been effected in the provinces, whilst numerous important sales have been concluded by private treaty. Ground-rents have again been eagerly sought after; the general price has averaged about 32 years' purchase. The year has seen a considerable increase in the demand for small freehold properties; building sites, both in the Metropolis and chief provincial centres, have been readily sold at good prices. Farms and agricultural land have not sold very readily.

## Intercommunication.

## QUESTIONS.

[11879].—Door Springs.—Can any reader give me the name of makers of the DeLancey hydraulic water-tight door-springs, Mackie's patent?—A. E. C.

[11880].—Quantities.—Should an architect supply his committee with a copy of the quantities when asked to do so, or should he refuse to comply with such request? The supplying of a committee with a copy of the quantities usually leads to interviews and explanations involving much loss of time and sometimes of temper; it becomes a waste of time, and sometimes is the fruitful source of mischief. I should be very glad to know what is the method generally adopted by the profession in this matter, and whether there is any established method of procedure regarding it.—C. D.

[11881].—Floor Calculation for Loads.—How is a floor area to be calculated? It is supported on four columns under two main girders. These columns divide the space into three parts of 20ft. each. The area altogether is 60ft. square. I want to know how the weight on each girder is to be found.—A YOUNG BUILDER.

[11882].—Brickwork Facing Measurement.—Will someone tell me the way adopted in taking off quantities of facings? There are gables included in the facing.—NOVICE.

[11883].—Hot Water Supply.—Which system of heating is mainly used for the warming of large buildings, like hotels, offices, and the like? A reader of the "B. N." may be able to give some particulars, which may be useful to others besides your correspondent.—A. G. S.

## REPLIES.

[11862].—Strength of Cast and Wrought Iron.—Your correspondent, "Yorks," puts a very pertinent question. What is the proper method of determining the sectional area of a cast-iron bracket upon a column, to receive the end of an iron or steel joist carrying, say, 50 tons—i.e., 25 tons strain on each supporting bracket, assuming the flanges of the joist to be 8in. wide. Also, what size ought a similar bracket of wrought iron to be? A year or so ago an account was published of the failure of cast-iron brackets on columns due to insufficient allowance for the tensile strain upon overhanging brackets. Do any of your correspondents remember the particulars?—LANCASHIRE LAD.

[11876].—Safe Load.—If the walls are good and the trusses are sound, a load of, say, 2½ cwt. to 3 cwt. per super. foot may be carried. The safe load will depend on the length of unsupported tie-beam. If the trusses are queen-post, the effective span is, of course, reduced, and the load carried will be greater than if there was only one post in the centre supporting the tie-beams. The scantlings given are substantial, and the trusses being only 8ft. 6in. apart, the unsupported area to be calculated will be the length of unsupported tie-beam by 8ft. 6in.—T. T.

[11877].—Attic Rooms.—The roof slopes and ceilings may be lined with asbestos or slag-wool. Slabs are made for this purpose composed of silicate cotton and plaster. Or the rafters may be fitted or pugged with slag-wool, as well as lined beneath, and felted roofs are also effective in arresting damp and cold. A layer of felt may be secured to bottoms of the rafters, and then boarded below.—G. H.

[11878].—Solid Floors.—The floor described by "Lancs" would resist fire for some time if the iron joists were protected below and the concrete made of a proper aggregate clinker, &c. The value of a solid floor as described is, that so long as it is impermeable or impermeable the flame cannot penetrate it, for as no draught or air can go through the solid floor the fire soon languishes from want of draught. The impermeability of a solid floor forms its main power of protecting the upper stories; when once it is pierced or the concrete cracks and falls out, the flames soon make headway and the floor is quickly destroyed. Hence the importance of keeping the floor solid and impenetrable, which can be secured only by using fire-resisting concrete that will not easily crack when fire and water play upon it. I believe an under-ceilings of asbestos suspended by metal from the solid floor above may be made to resist flames for a considerable time. The upper solid wood joists, with concrete between as described by "Lancs" form a much better floor than one with open joists.—G. H. G.

Sir John Gilbert's personal estate has been valued at £231,584. The testator bequeathed to the Trustees of the Royal Society of Painters in Water-Colours, of which he was the president, his portrait in oil as a gift to the said society.

In the case of Walter Albert Williams, Tower House, Bromley, S.E., Regent-street, W., and Netherfield, Battle, Sussex, described as an architect and farmer, the order of discharge has been suspended for two years ending Dec. 7, 1899. (Public examination concluded April 18, 1893.)

The work of restoring the parish church of Stratford-on-Avon was recommenced on Tuesday. A good deal has been done within the last ten or twelve years, but beyond taking down the galleries in the side aisles and removing the whitewash from the walls and clerestory, nothing has been done to the nave. The work now commenced includes the removal of the pews from that part of the church, preparatory to the relaying of the floor, and the provision of a new system of heating. The contractors for the work in the nave are Messrs. Smith and Son, of Milverton, and for the heating apparatus Mr. John Grundy, of Manchester and London, the architect for the whole scheme of restoration being Mr. G. F. Bodley, A.R.A.

CONTENTS.

Progress of the Architectural Crafts	1
The Millais Pictures at the Royal Academy	2
The Taxation of Land Values	3
Academy Architecture, 1897	3
Effect of Sea-Water on Cast Iron	4
Sanitary Inspectors' Association	5
Obituary	5
New Operating Theatre, Dunedin, New Zealand	6
Lord Leighton Memorial, Camberwell	6
Competitions	7
Correspondence	8
Intercommunication	8
The Building News Directory	XIX.
Our Illustrations	9
Building Intelligence	47
Legal Intelligence	47
Our Office Table	47
Meetings for the Ensuing Week	48
Trade News	48
List of Competitions Open	49
List of Tenders Open	49
Tenders	50
Latest Prices	51

ILLUSTRATIONS.

ST. GEORGE'S CHAPEL, WINDSOR.—HOVE PARISH CHURCH.—THE "ROYAL" MUSIC HALL, HOLBORN.—NEW PREMISES IN REGENT STREET.—THE HOUSES OF THE GUILDS, GHENT.—"THE HARE AND THE TORTOISE."—ENTRANCE OF THE PALAZZO DURAZZO, GENOA.—BRUTON CHURCH, SOMERSETSHIRE.—DOMINICAN PRIORY, HAWKESYARD.—HOTEL DE LA BOURSE, CAEN.

Our Illustrations.

ST. GEORGE'S CHAPEL, WINDSOR.

THE interior of St. George's Chapel, Windsor, and especially the choir of which a view is here given, is worthy of the Patron Saint of England. The style is Late 15th century, not yet run to seed in groinings and lacework in stone, yet the fanwork, panelling, and pendants of the roof are soberly rich, as befits the Freemasons Hylmer and Vertue who made them. But decoration and carving run riot in the oaken stalls of the Knights of the Garter, headed by their crested helmets, and shaded by silken banners—a grove of heraldry. Over all falls the varied colours of the stained windows. The chapel was founded by Edward IV., but not completed till the time of Henry VIII. Both these monarchs, who so freely beheaded their subjects, are here buried; so is Charles I., whose subjects beheaded him; so are also Henry VI., George III., William IV., while the burial here of the late Duchess of Teck is still fresh in the memories of readers of the BUILDING NEWS. Our plate is reproduced from a drawing by Mr. Charles Bird.

HOVE PARISH CHURCH, BRIGHTON.

A FEW days before his death last month, the late Mr. J. L. Pearson, R.A., lent us the drawing here-with reproduced in illustration of this imposing and well-designed church, which is one of his more recent works. So very seldom did Mr. Pearson care to have his designs illustrated, that the circumstance thus briefly alluded to adds an additional interest to the illustration, and having but lately seen the building itself, so far as its execution has been carried out up to the present, we can speak of the ability and original taste displayed by the detail and design of the church, which merit the warmest praise. The drawing, as a matter of fact, hardly does the building justice. It stands at the corner of "The Drive" and Eaton-road. The accommodation is for 1,270 worshippers. The narthex at the west end will form the principal entrance. The nave is 108ft. long by 35ft. wide, and nearly 75ft. high. It is divided into six bays, and a feature is made of the baptistery. A triforium is omitted, in recognition of the parish-church treatment in distinction from that of an abbey church. The clerestory is comparatively low, after the English type, and the sills are about 40ft. from the floor. The eastern bay of the nave is much wider than the rest, and opens on the north and south sides into transepts; these arches occupy the entire height of both nave arcade and clerestory. The big traceried window at the west end mainly lights the nave, the glass area being 32ft. by 17ft. The roof is of oak, handsomely braced and framed in simple lines. The chancel is of three bays, and the sanctuary beyond makes the most effective feature in the church, as it should do. It is 23ft. long by 27ft. wide, and is entered by an arch 58ft. high, and the walls are carried up to 55ft. ;

this enhanced height and reduced width combine to produce an extremely lofty effect, which stands in marked contrast to the broader treatment of the nave. The reredos contemplated is to be of stone, and will cover the lower part of the entire east wall with sculptures in illustration of the life of Our Lord. The south aisle is 21ft. wide, that on the north being 16ft. All the doors open outwards, and are wide enough to admit Bath chairs. South of the choir is a morning chapel, 46ft. long by 21ft. wide. The western gable reaches 77ft. high. The tower parapet will measure 140ft. A pleasing feature is made by the south porch having sculptured figures in relief in the gable over a richly-moulded arch of elegant design. The vestries, and the room over them, are of a semi-Domestic character. The organ is lifted up, and located well for musical effect.

"ROYAL" THEATRE OF VARIETIES AND "ROYAL" BIJOU RESTAURANT, HOLBORN.

THE "Royal" Music Hall has been a landmark in Holborn for many years. Originally known as Weston's Music Hall in the old days, it was enlarged and remodelled by the then owner, Mr. Purkiss, who successfully carried on this most popular house of entertainment. Eventually the property passed into the hands of Mr. John Brill, who, immediately upon obtaining possession, decided to effect drastic alterations in the approaches to the building and generally to improve the accommodation for the public. An entirely new front of terracotta has been erected, embracing not only the original approach, but the adjoining property, No. 243, High Holborn; the entrance-hall has been made larger, new staircases built, and also a spacious saloon, with ample lavatory accommodation. The auditorium also has been redecorated and reupholstered, and a so-called bijou restaurant upon the upper floors arranged, capable of dining upwards of 80 persons. The remodelling of the "Royal" has been carried out from the designs and under the superintendence of Mr. Ernest Runtz, architect, of No. 10, Walbrook, E.C.

NEW PREMISES IN REGENT STREET.

THE building now in course of erection on the Hanover Chapel site, Regent-street, for Mr. T. H. Brooke-Hitching, from the designs of Mr. G. D. Martin, architect, 3, Pall Mall East, S.W., will consist of nine floors, inclusive of basement and sub-basement, the whole surmounted by a bold dome of polygonal form covered with copper, containing large room lighted by eight projecting louvres, the dome being terminated by an open cupola. The ground floor will be divided into four handsome shops with central entrance to upper floors, separated by red Aberdeen granite pilasters, and in the rear of shops there will be a large hall or show-room. The mezzanine floor, consisting of show-rooms to main cornice, will be executed in red terracotta, while the five upper floors will be carried out in Portland stone of bold treatment, and will comprise about 64 well-lighted offices, lavatories, &c., approached by grand staircase and hydraulic elevator. The whole of the floors and partitions will be of fire-proof construction.

THE HOUSES OF THE GUILDS, GHENT.

THIS plate is reproduced from Mr. A. Wallace Rimington's charming etching, published by him under the above title. The view represents the well-known Quai aux Herbes with the famous *Maison des Bateliers*, the most picturesque house in Ghent, to the right hand of the picture. The Guild of the Watermen's Craft held its meetings here, and their insignia, with the arms of Charles V., are carved on its gables, which date about 1513. The *Halle au Blé* is an earlier building of Domestic Gothic, belonging to the early part of the 14th century. The towers of the Church of St. Nicholas and of the Hotel de Ville appear over the gables on the waterside. We published on July 30, 1897, other sketches of this quayside at Ghent, by Mr. John D. Walker, of Bradford.

STUDIES ILLUSTRATING THE FABLE OF "THE HARE AND THE TORTOISE."

WE commence to-day a series of drawings showing the adaptation of Animal Forms to Decorative Design, with details artistically indicating the leading characteristics and habits of the birds and beasts chosen for illustration and study. Our first sheet comprises the National Silver Medal drawings by Mr. George Marples in illustration of the well-known fable of "The Hare and the

Tortoise," and this admirable sheet may be taken as fairly representing the value and interest of the suggestive series thus commenced. The originals are in colour, which we cannot, of course, reproduce; but the monochromes will be found to do the designs justice.

ENTRANCE OF THE PALAZZO DURAZZO DELLA SCALA, VIA BALBI, GENOA.

THIS Genoese Palace is too well known to need a description here; but illustrations of the building have not often been given, so that the pencil-drawing which we print to-day should be found useful, and it serves as a companion study to that of the Cortile of the Palazzo Balbi also at Genoa, which we published from the same hand in the BUILDING NEWS, Jan. 3rd, 1896. Both buildings are very similar in detail, and in some points are identical in design, while both are associated with their adjoining neighbour 'the Palazzo dell' Università, which in itself as a building is chiefly famous for its magnificent staircase, guarded by most grand lions.\* The Palazzo Durazzo della Scala is remarkable mainly on account of its beautiful court surrounded by marble columns, and approached by a staircase with a triple row of steps. The Palace is possessed of the Pallavicini collection, as the Marchesa Durazzo was the daughter and heiress of the late Prince Pallavicini. Among the pictures are examples by Albert Dürer, Vandyke, Rubens, Guido Reni, Andrea del Sarto, and other masters. The two statues flanking the piers, which divide the staircase leading to the inter-columniated court of this palace, considerably enhance its grace and interest, showing the immense value of sculpture well-placed and sparingly used as the concomitant of good architecture.

We loved that hall, tho' white and cold,  
Those niched shapes of noble mould;  
A princely people's awful princes,  
The grave, severe Genoese of old.

BRUTON CHURCH, SOMERSET.

THIS view of the beautiful and typical tower of Bruton Church, Somerset, is taken over the rambling and somewhat ramshackle old stone-built houses of the village street, making, when seen together, an exceedingly picturesque group, though these crumbling roofs necessarily hide the body of the parish church itself. The Brue, a shallow stream which finds its source in the neighbourhood of the town, gives to it the name of Bruton. There are several points of interest in the place apart from the church, and the uncommonly large number of richly-wrought signs to the several inns in the main street, particularly that outside "The Old Ball," add materially to the quaintness of the picture. The old hospital, too, founded by Hugh Sexey in A.D. 1617, has a small quad and charming hall, as well as a chapel in Late Domestic Gothic, a capital instance of simple vernacular work, thoroughly Mediæval in spirit, though built so long after the tastes of the day elsewhere had seen a material change towards the Renaissance. The church at Bruton was evidently designed by a most accomplished architect, and his work takes its place alongside the towers of Evercreech, Wrington, Wells, Glastonbury, Norton Fitzwarren, Ilminster, and Taunton; while in its proportions and actual beauty of design it surpasses many of these, although in point of size the Bruton tower cannot, of course, compete with the larger of them. There is an illustration of this tower in the Somersetshire *Archæological Proceedings* for 1852, p. 16. The importance of the elevation is much enhanced by the smaller tower over the porch in the north aisle. The roofs of the church are of much richness, and the traceried ribs of the nave roof tie-beams are somewhat unusual. The clerestory windows have beautiful niches between them, with rather well-carved modern angels introduced throughout. The crypt under the chancel is Transitional Norman; but the choir itself is a good specimen of florid Georgian, done in plaster. The west-end screen bears the date 1620, and the original Perpendicular screen from the chancel was incorporated with it seemingly when this work was done. The Jacobean pulpit and pew-ends are also worth mentioning, and when the late Mr. Herbert Carpenter restored the roofs and rebuilt the north arcade in 1874 he copied these old seats for the design of the new ones. The accompanying drawing, from a sketch made some years ago, has been completed with the

\* See BUILDING NEWS, Sept. 17, 1897, for Views.

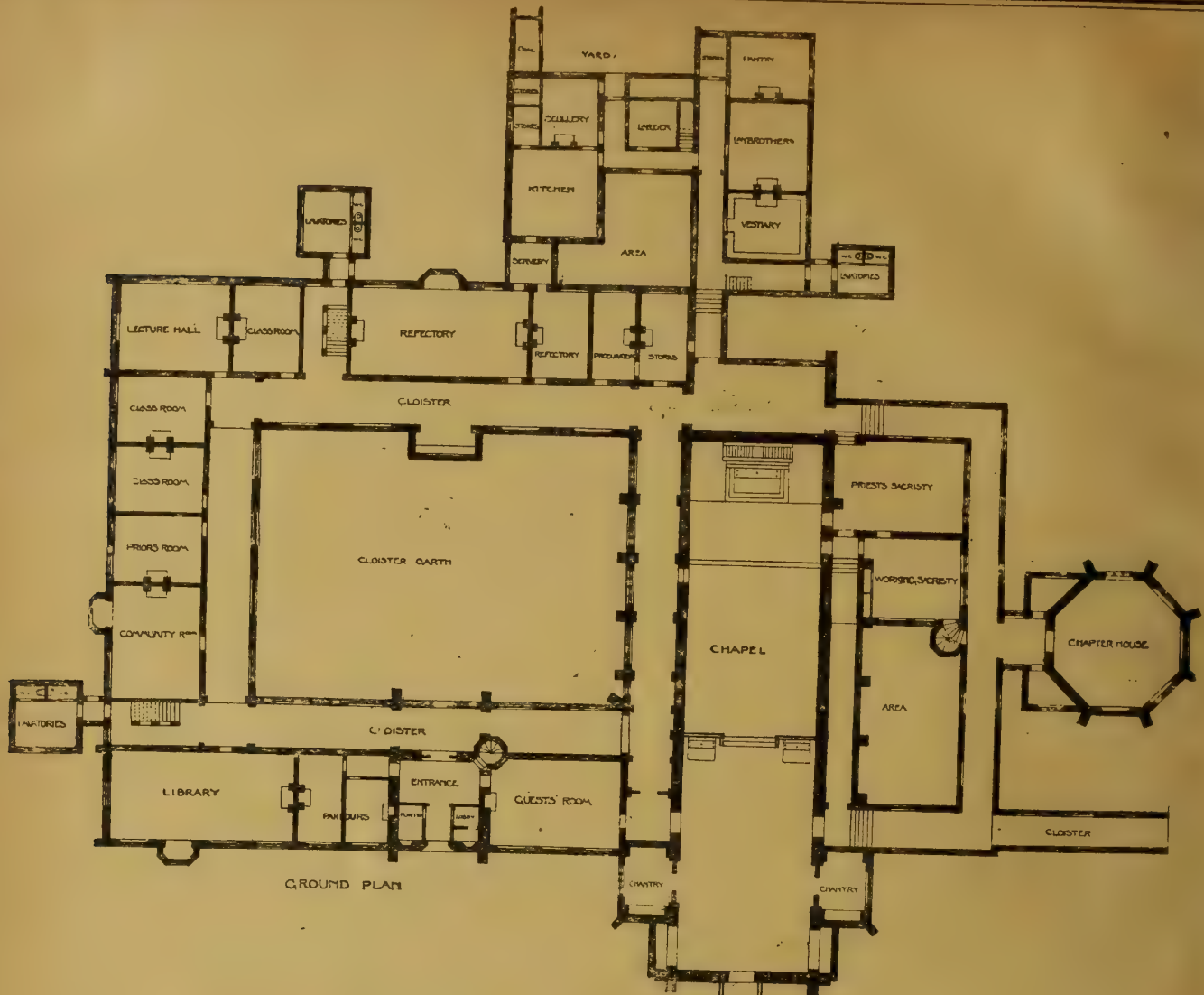

HAWKESYARD PRIORY, NEAR RUGELEY.

EDWARD GOLDIE, *Architect.*

aid of a photograph taken by the late Mr. John L. Robinson, R.H.A., in 1894, during the second visit of the Architectural Association Excursion in the Wells district. Some sketches of the signs and brackets in wrought iron referred to in these notes will be found illustrated by Mr. Maurice B. Adams in the *BUILDING NEWS* for Nov. 24, 1882.

## DOMINICAN PRIORY, HAWKESYARD.

This building, situated in a beautiful estate near Rugeley, Staffordshire, is now in progress. The finished portions include the chapel, the west wing, and the kitchen block, while work has been begun on the south wing. The design was originally intended to be carried out in Penkridge stone; this, however, has been substituted by red brick for the walling with dressings of the above-mentioned stone, the roofs being covered with green slates. The treatment throughout has been kept plain and simple, except in the church, where the chantry chapels, the forty-four canopied stalls in the choir, and the high altar are all of elaborate workmanship. The organ, which came originally from Eton, is a good specimen of 18th-century work; it is being rearranged, and will occupy a position on corbels against the choir wall. The architect is Mr. Edward Goldie, of 10, Kensington-square, W., and the contractors Messrs. Parnell and Son, of Rugby. Our illustration is taken from the drawing exhibited by the architect at the Royal Academy last summer.

## HOTEL DE LA BOURSE, CAEN.

The large number of important and historic buildings in Caen somewhat overcome and obscure this comparatively small but none the less exceedingly interesting building, the courtyard of which forms its main feature. Formerly known as the Hotel de Valois, it has long been used as the Hotel de la Bourse. A great feature was made by its designer of the arched entrance

situate in the corner of the little quad. Sculpture is used freely and with much taste—indeed, the composition, as a specimen of the best period of the French Renaissance of the 16th century, takes its place very decidedly among the most admirable examples of the north-west of France. This is high praise for so restricted a work, but it is its merit architecturally, and not its mere size or relative importance of scale, which occasions our remark. Many more influential edifices could be mentioned, of course, but few deserve more attention or are really more suggestive. Our illustration is reproduced from a spirited line drawing by Mr. J. C. Halden for our contemporary, the *American Architect*.

## CHIPS.

A Jubilee commemoration bridge is being built at Thorpe Haven, Aldeburgh, from plans by Mr. W. Sandercock Randall, of Old Charlton, S.E. The first stake was driven with public ceremony last week.

The Hackney Vestry have decided to contribute £5,000 towards the cost of reconstructing the Cat and Mutton Bridge. The work will entail an outlay of £67,490.

Tewkesbury Abbey, perhaps the noblest parish church in England, needs further restoration. Between 1877 and 1890 £11,000 was spent on it, under the direction of the late Sir Gilbert Scott and his son Mr. J. Oldrid Scott. The Archdeacons of Gloucester and Bristol and the vicar of the parish are now seeking the aid of church people at large in the work.

The Louth town council, having applied to the Local Government Board for approval of the borrowing of £1,300 for the erection of a technical school, Colonel C. H. Luard, R.E., held an inquiry into the subject matter of the application at the town hall, Louth, on Tuesday. The building will be erected from plans by the borough surveyor, Mr. G. H. Allison.

The Board of Trade have, after modification, confirmed an order made by the Light Railway Commissioners authorising the construction of the Basingstoke and Alton Light Railway.

Mr. W. F. Woods, head draughtsman in the Bootle borough engineer's and surveyor's department during the past three years, is about to proceed to Sierra Leone, West Coast of Africa, having obtained a position there.

At a meeting of the building committee of the Royal Cross School for the Deaf at Blackburn, held on the 31st ult., Messrs. Sames and Green, of Blackburn, the architects were instructed to proceed at once to procure tenders for the extension of the school, at an estimated cost of £3,600, the whole of which has been promised by Archdeacon Rawstone.

Sir E. A. Bond, K.C.B., L.L.D., who, in 1878, became principal librarian of the British Museum, and retired in 1883 after a tenure of office which was marked by the introduction of several important improvements in the arrangement and management of the library, died on Sunday at his residence in London. He was made a C.B. in 1885, and the long-deferred advancement to K.C.B. was only announced the day before his death.

The county hospital at Huntingdon has just been enlarged and improved from plans by Mr. E. Borrisow, Mr. Keith D. Young, of London, being employed as consulting engineer. The outlay has been about £3,000, and the works include a new operating-room, the remodelling of the drainage and erection of new sanitary blocks, and the substitution of teak floors, supplied by Messrs. Roberts, of Islington, for old ones of deal.

Mr. G. W. Wilcocks, C.E., one of the inspectors of the Local Government Board, held an inquiry at the Shirehall, Shrewsbury, on Friday, as to the proposal of the corporation of the borough to borrow £48,000 for the purpose of a new water supply. Evidence in support of the application was given by Mr. E. B. Taylor, of the firm of Taylor, Sons, and Santo Crimp, the engineers of the scheme proposed to be carried out.

# **BOYLE'S PATENT**

## **"AIR-PUMP" VENTILATOR**

(LATEST PATENT)

HAS

**Double the Extracting**

**Power**

OF EARLIER FORMS, AND IS

**ONE-HALF THE PRICE**

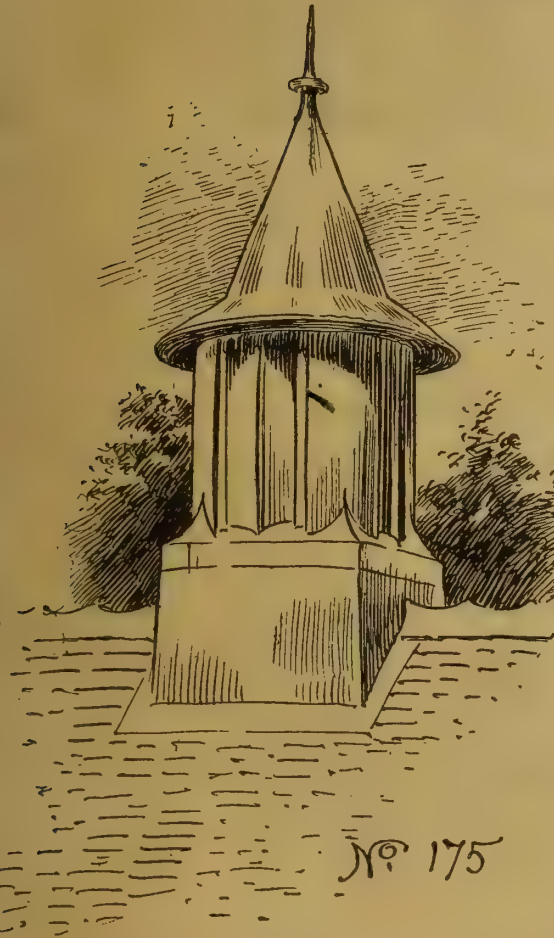

The plainest design (No. 175) is now made of a more ornamental and architectural character, of the best rolled steel plates, galvanised and painted, whilst the workmanship is of the highest class.

N.B.—When Specifying or Ordering, the following formula should be used:—“**BOYLE'S PATENT 'AIR-PUMP' VENTILATOR**, Design No. 175. Diameter of head  
Diameter of pipe . . . No required . . . Price each . . .”

# **ROBERT BOYLE & SON, Ltd.**

**VENTILATING ENGINEERS,**

**64, Holborn Viaduct,  
LONDON.**

**110, Bothwell Street,  
GLASGOW.**

CATALOGUES, PRICE LISTS, &c., MAY BE HAD ON APPLICATION.

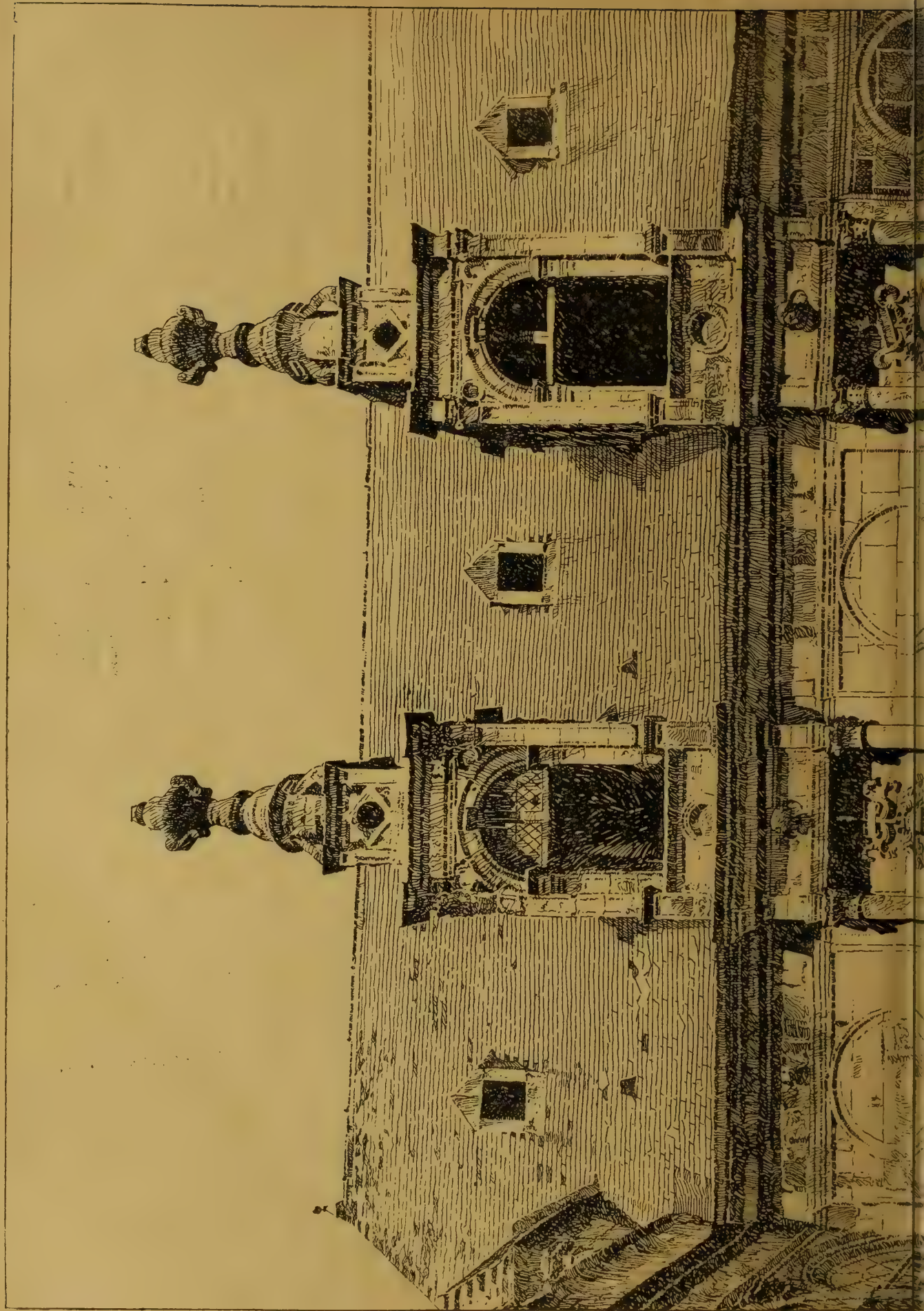



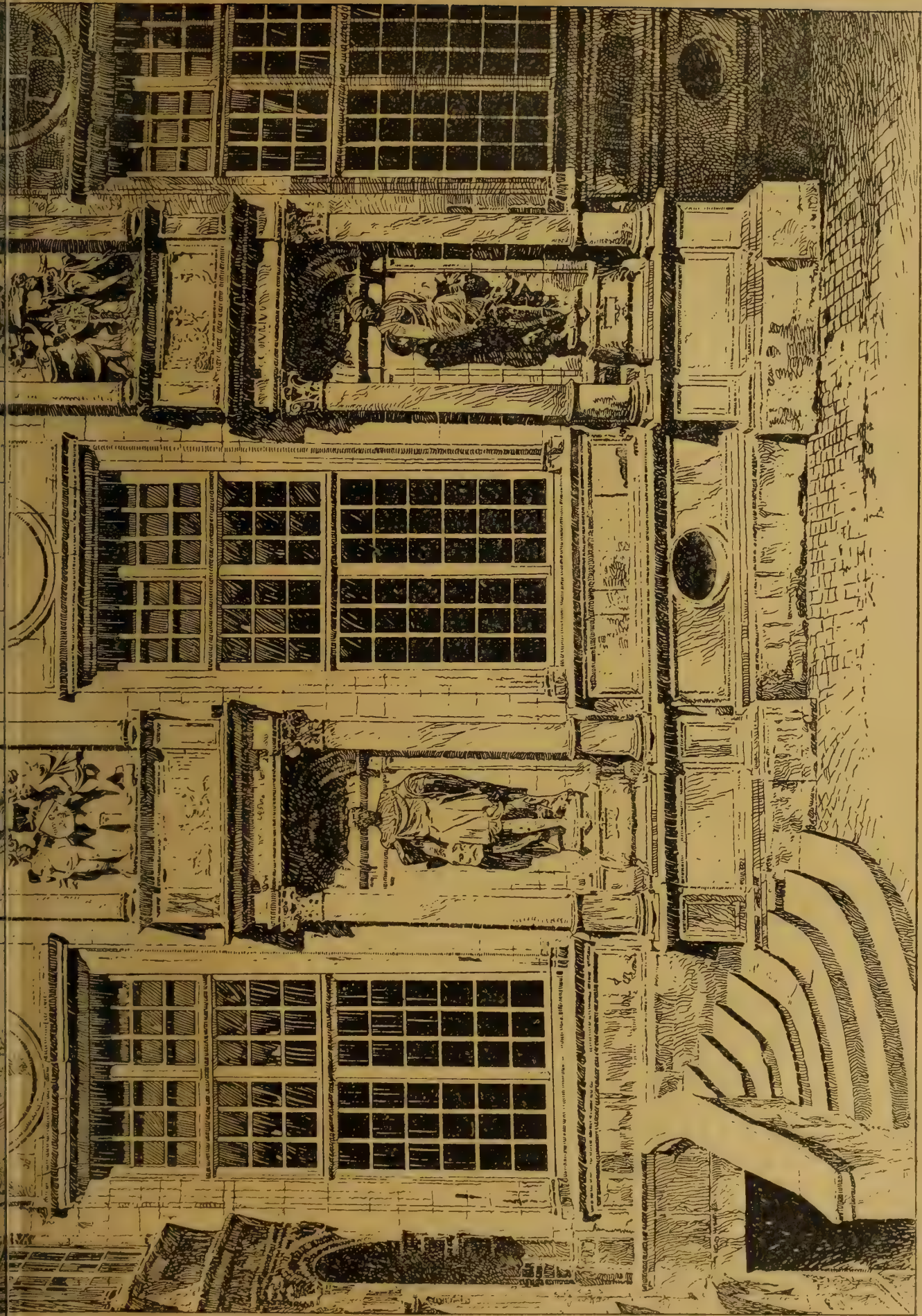

J. CHALDEN · 1897.

· HOTEL DE LA BOURSE · FORMERLY · HOTEL DE VALOIS ·  
· CAEN · XVI · CENTURY ·

# HOBBS, HART & CO., LTD.,

ORIGINAL MAKERS OF THE

## “SEAMLESS” BENT BODY STEEL SAFES.

PATENT PROTECTOR UNPICKABLE AND MACHINE-MADE LOCKS.

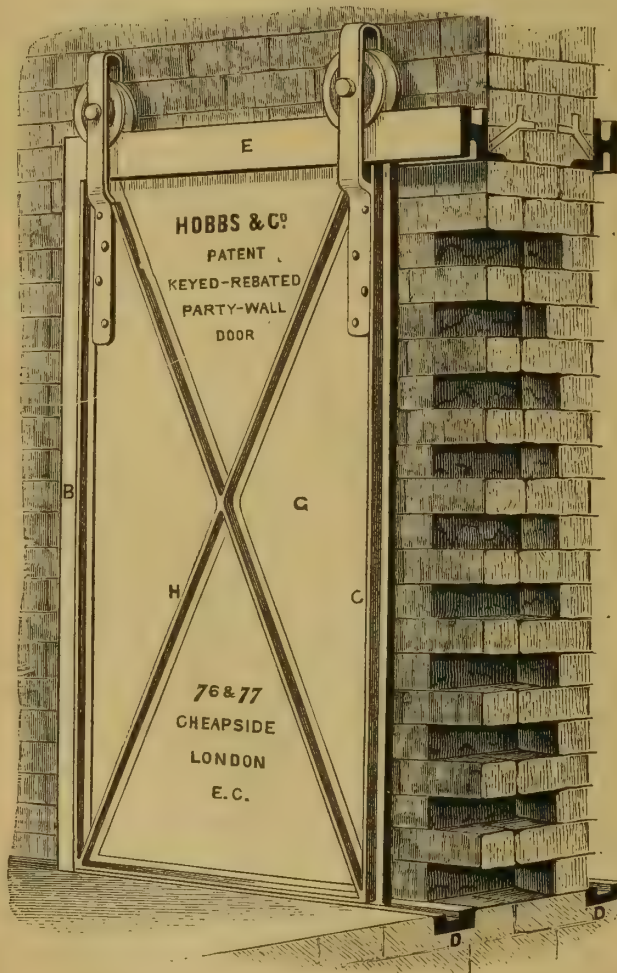

*Conformity to Building Acts, County Council, or Fire Insurance Committee may enable owners to effect Insurances, but is by no means a Guarantee that the best means for the Absolute Protection of Valuables has been adopted.*

### SAFES, DOORS, STRONG ROOMS, LOCKS, &c.

REPRESENTATIVE SENT TO CONFER WITH ARCHITECTS OR SURVEYORS DESIRING TO SPECIFY.

*The Steel Doors and Gates of this Company are of Superior Construction, and have acquired a high reputation. Where absolute security is needed, the "Keyed Rebated Party-Wall Doors," which have been supplied with so much satisfaction to many leading Architects, will be found as near perfection as is practicable. It is a noteworthy fact to be remembered that in all recent fires were conformity to the Building Act for Party-Wall Doors has proved to be disastrous.*

FULLY ILLUSTRATED LISTS

— OF —

SAFES, DOORS, GATES,

GENERAL LOCK LIST,

CABINET LOCK LIST,

ON APPLICATION FREE.

PATENT CONE VENTILATORS.

FOR STRONG ROOMS OR VAULTS.

SHOWROOMS : 76, CHEAPSIDE, E.C.

GENERAL OFFICES  
AND WORKS :

(Where all Communications should be sent)  
ARLINGTON STREET, ISLINGTON, N.

**HOBBS  
HART  
& CO. LD.  
CLUTCH  
REBATED  
PARTY  
WALL  
DOORS**



THE BUILDING NEWS, JAN. 7, 1898.

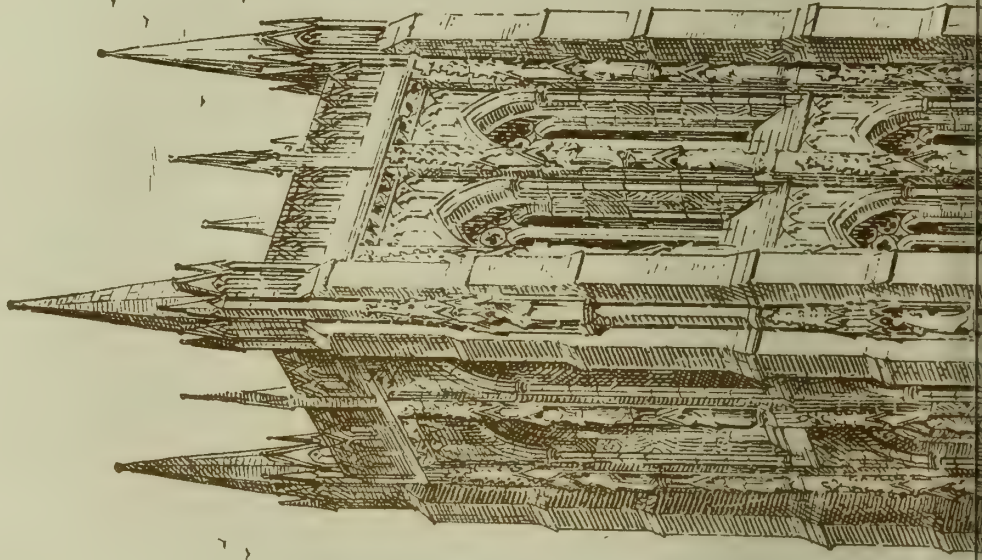

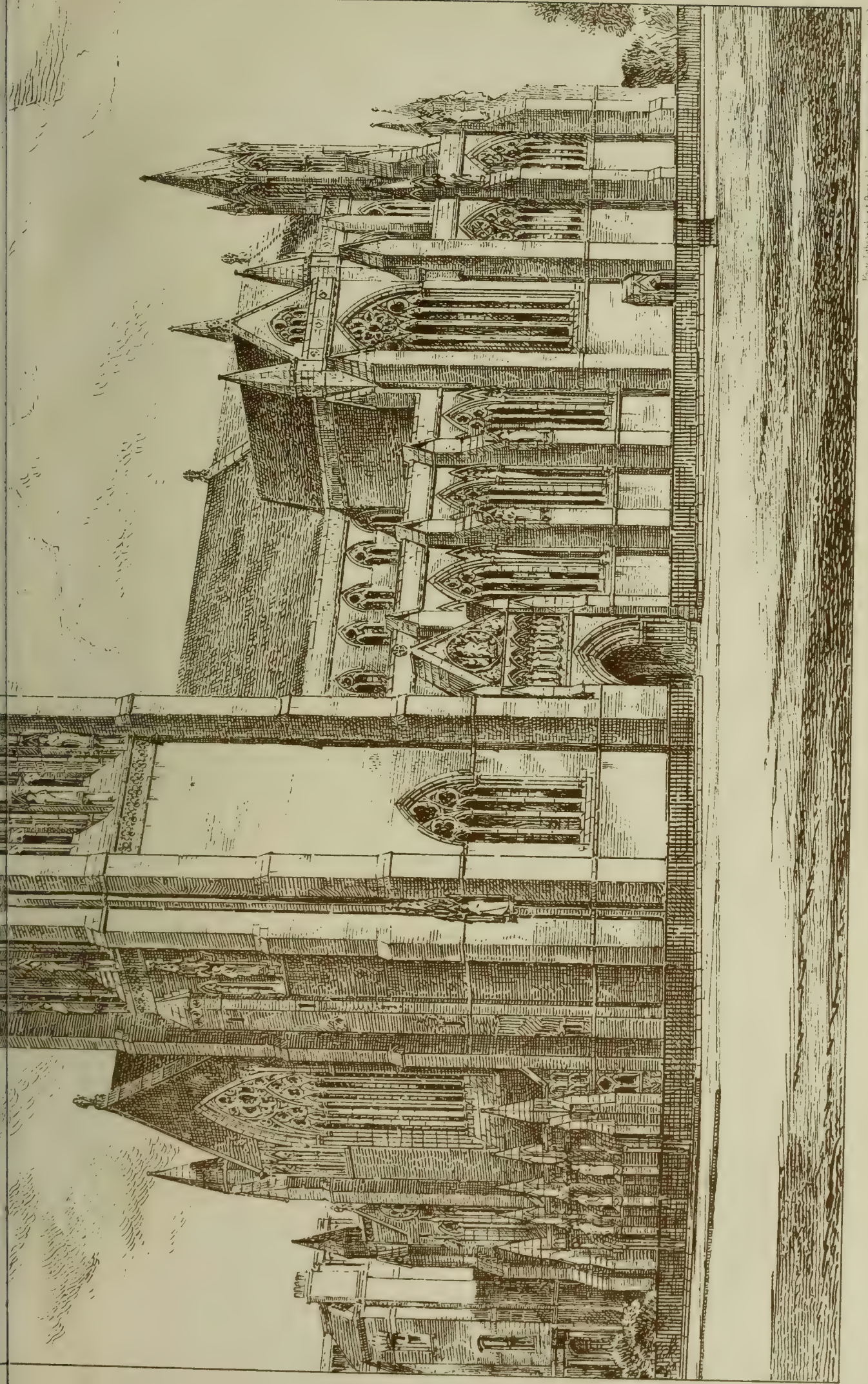
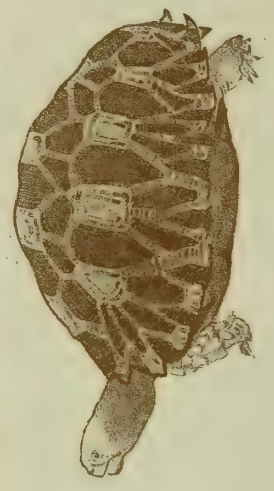
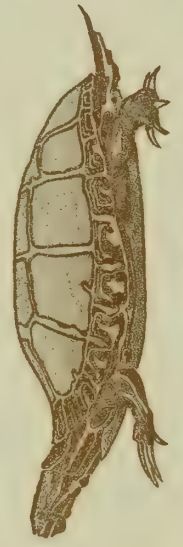

Photo Lithographed & Printed by James Albertson in Queen's Square W.

HOVE PARISH CHURCH (ALL SAINTS) S.W. VIEW. THE LATE J. L. PEARSON R.A. ARCHT.











STUDIES FOR ILLUSTRATING THE FABLE

OF THE HARE & THE TORTOISE

NATIONAL SILVER MEDAL AWARDED

GEORGE MARPLES

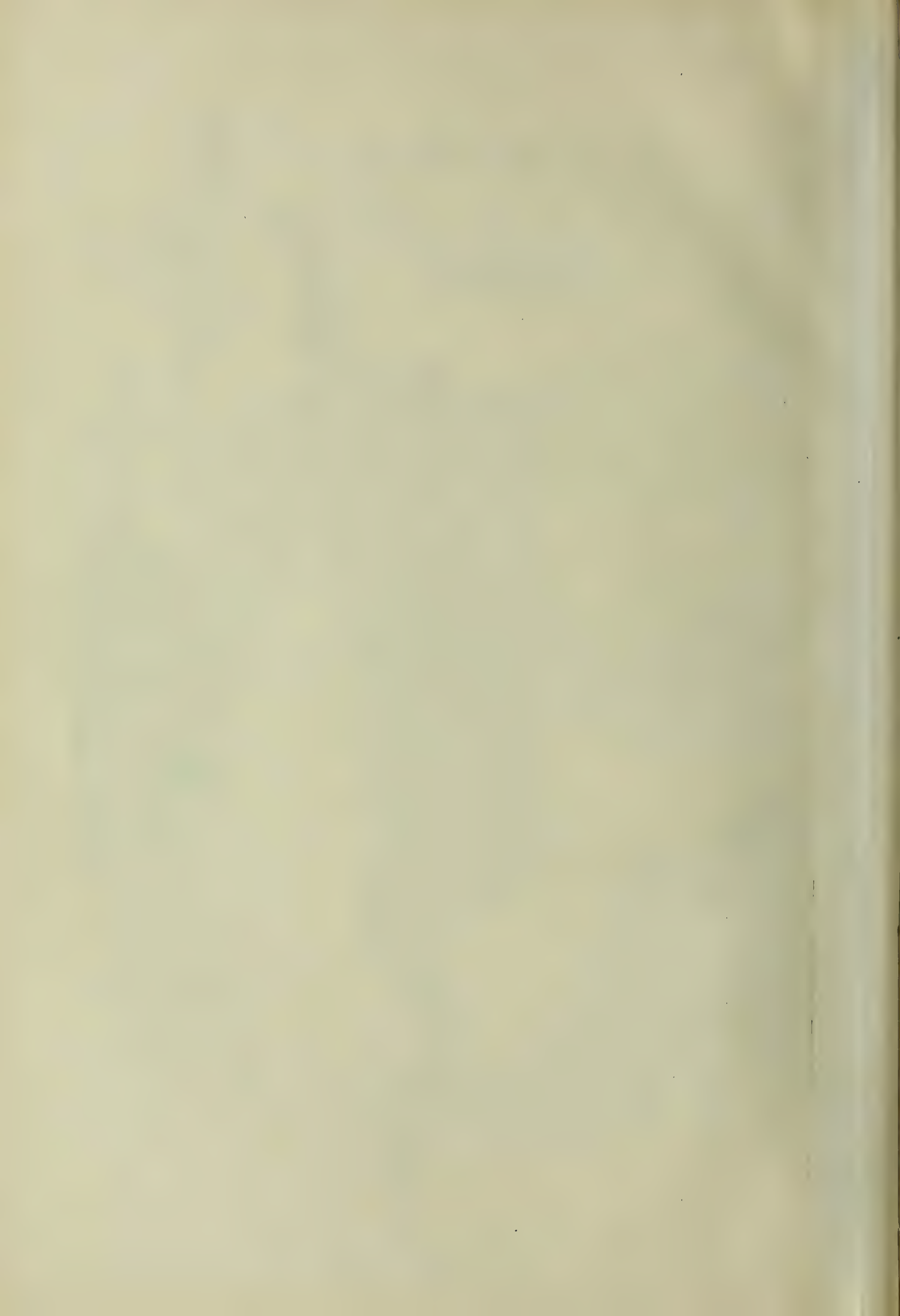



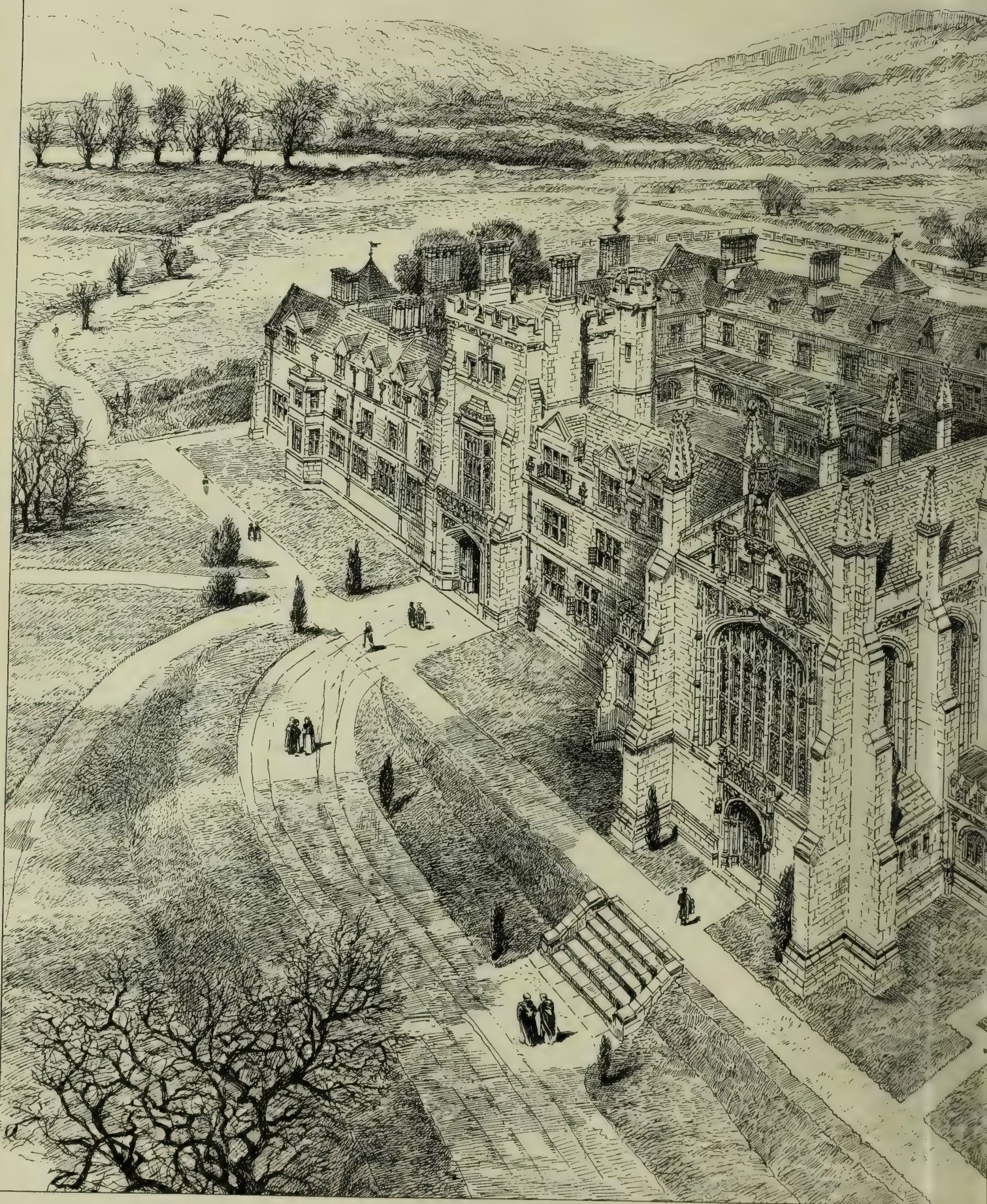

HAWKESYARD PRIORY NEAR RUGELEY ST.

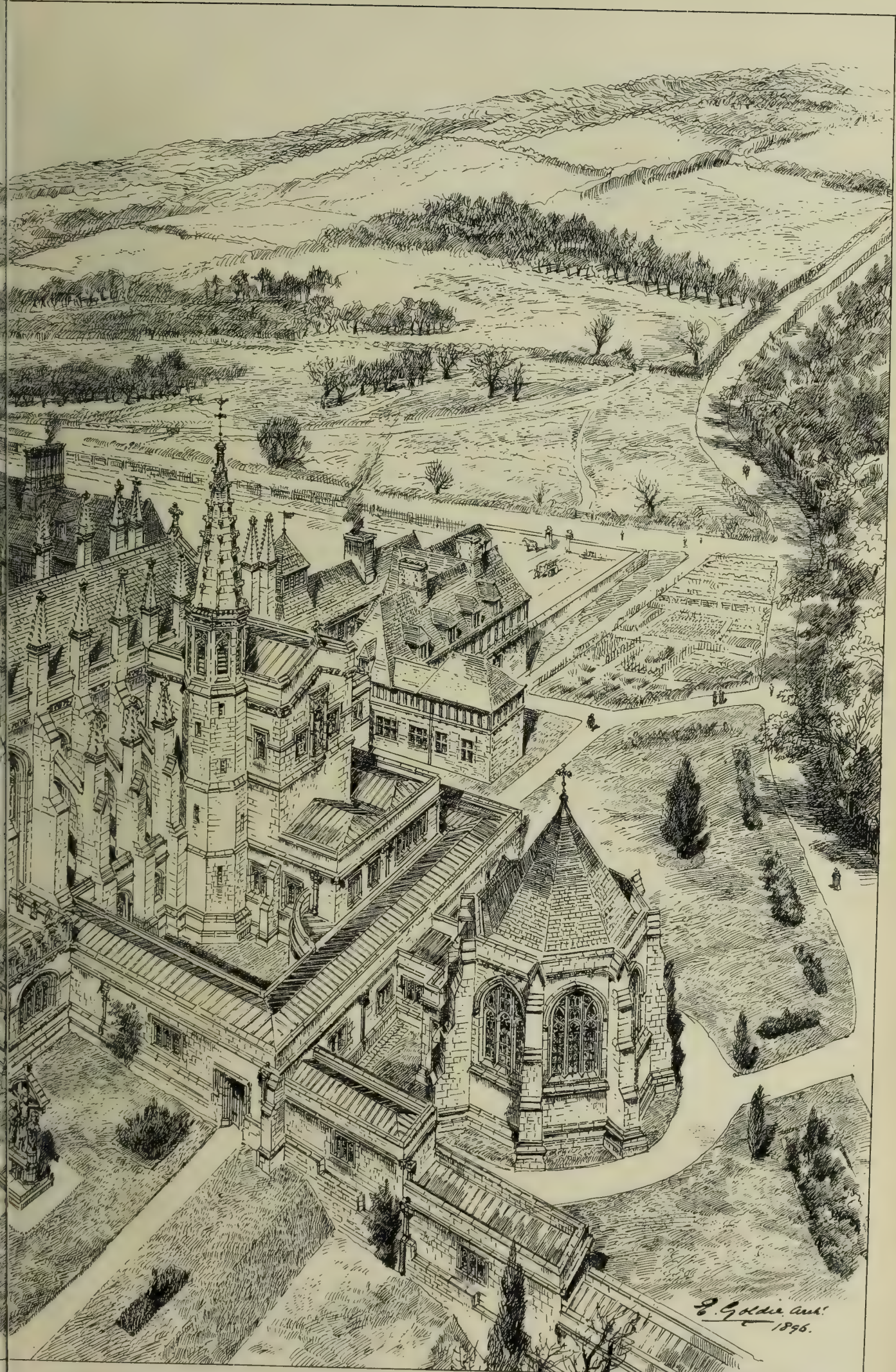

*E. G. Goldie Archt*  
1896.





THE BUILDING DEWS, JAN. 7, 1898.

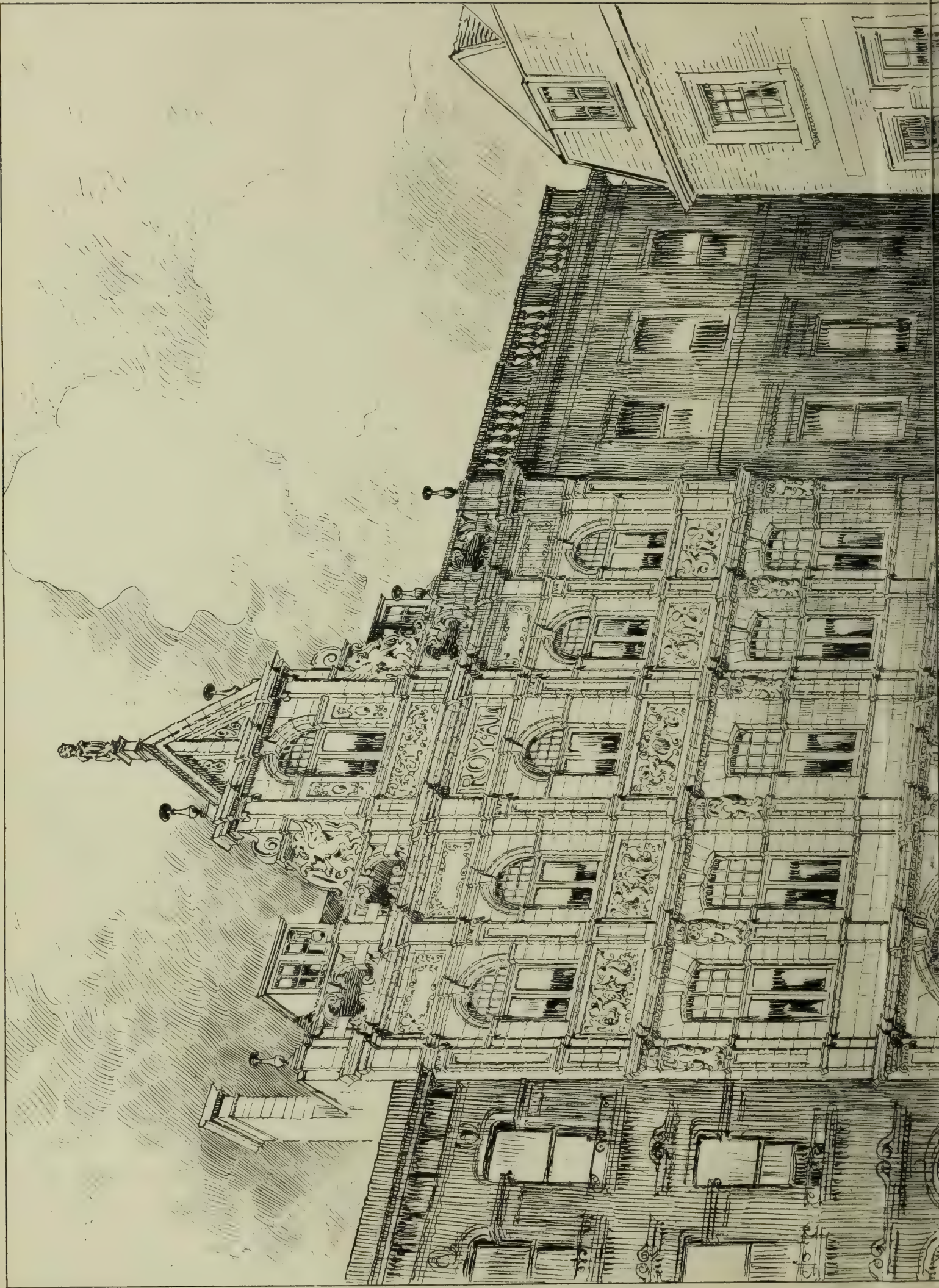



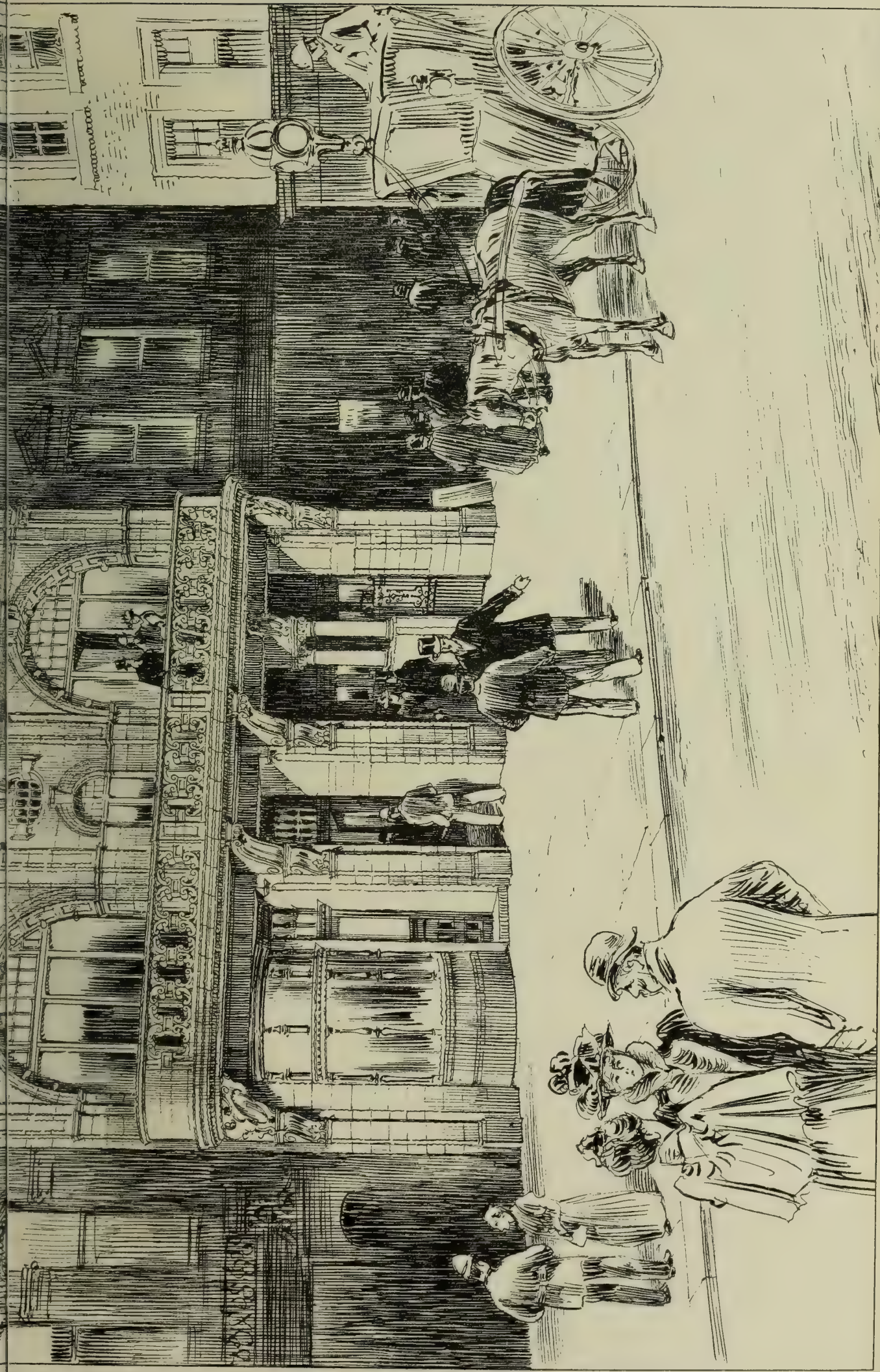

Photo Lithographed & Printed by James Alberman, 6 Queen Square W.C.

The Doctor, Misses May, Lord, and...







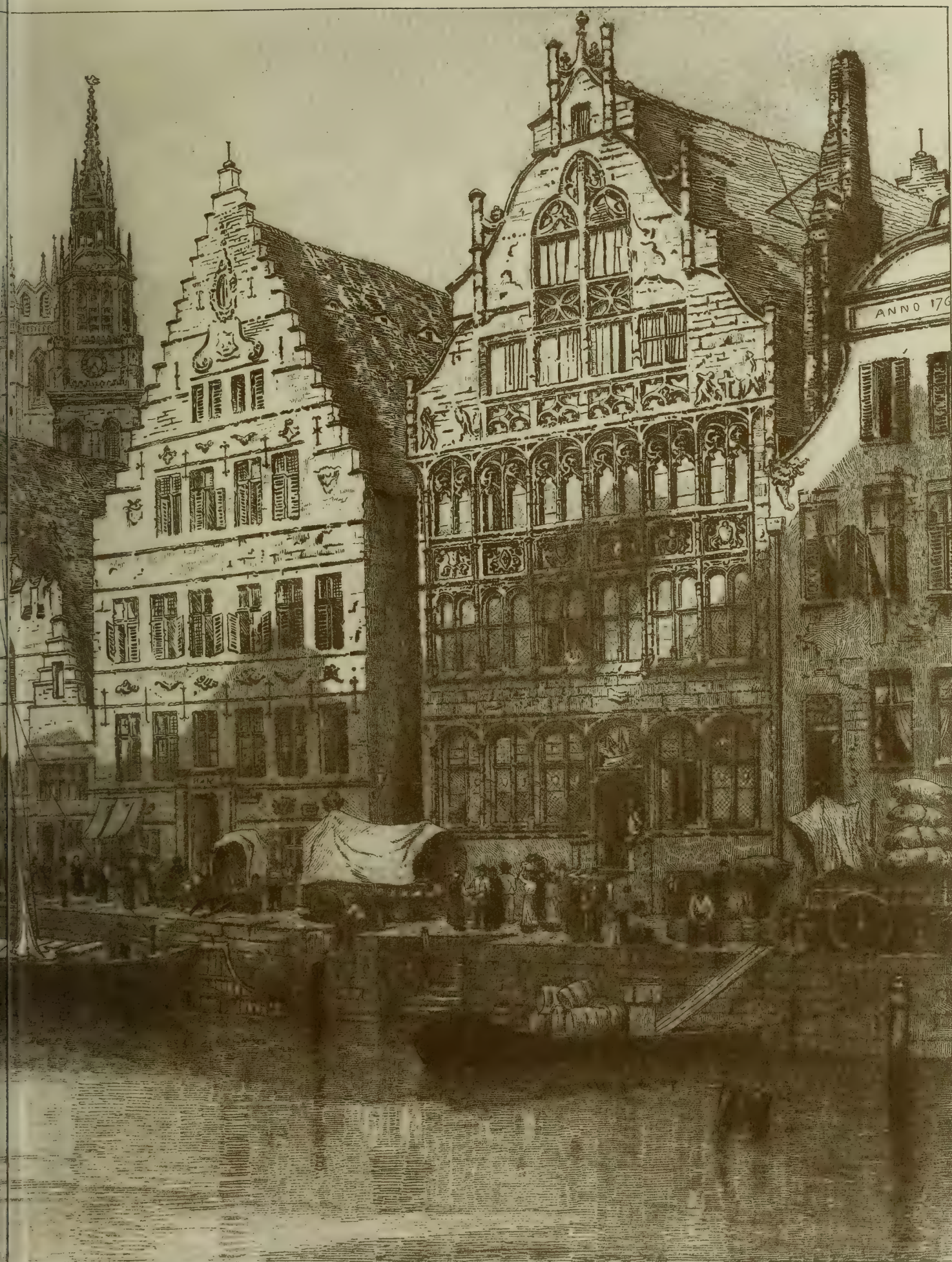

"PHOTO-TINT" by James Akerman in Queen Square London W.





THE BUILDING DEW'S, JAN. 7, 1898.

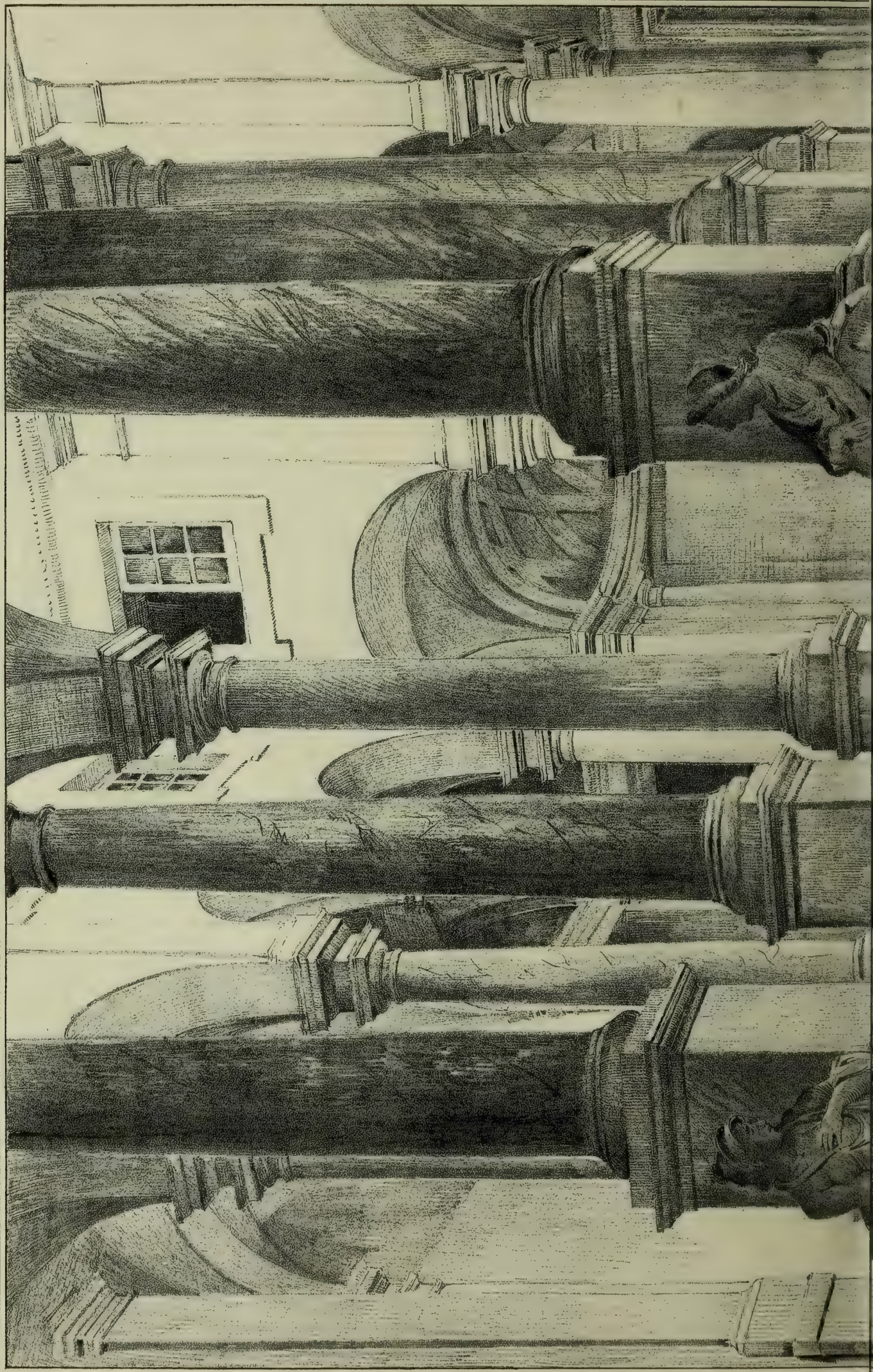



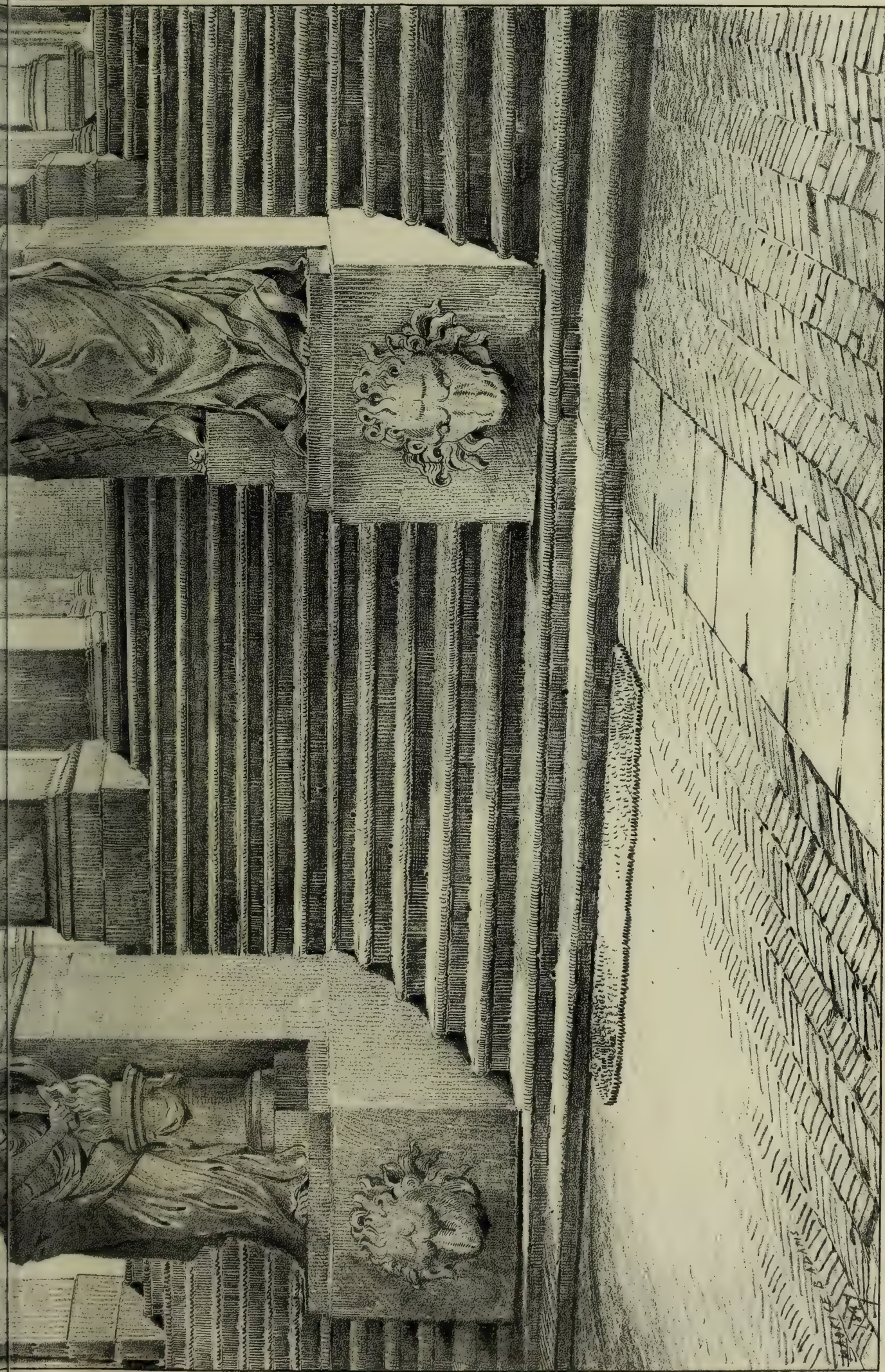

ENTRANCE OF THE PALAZZO DURAZZO, VIA BALBI, GENOA. DRAWN BY MAURICE B. ADAMS FRIBA.





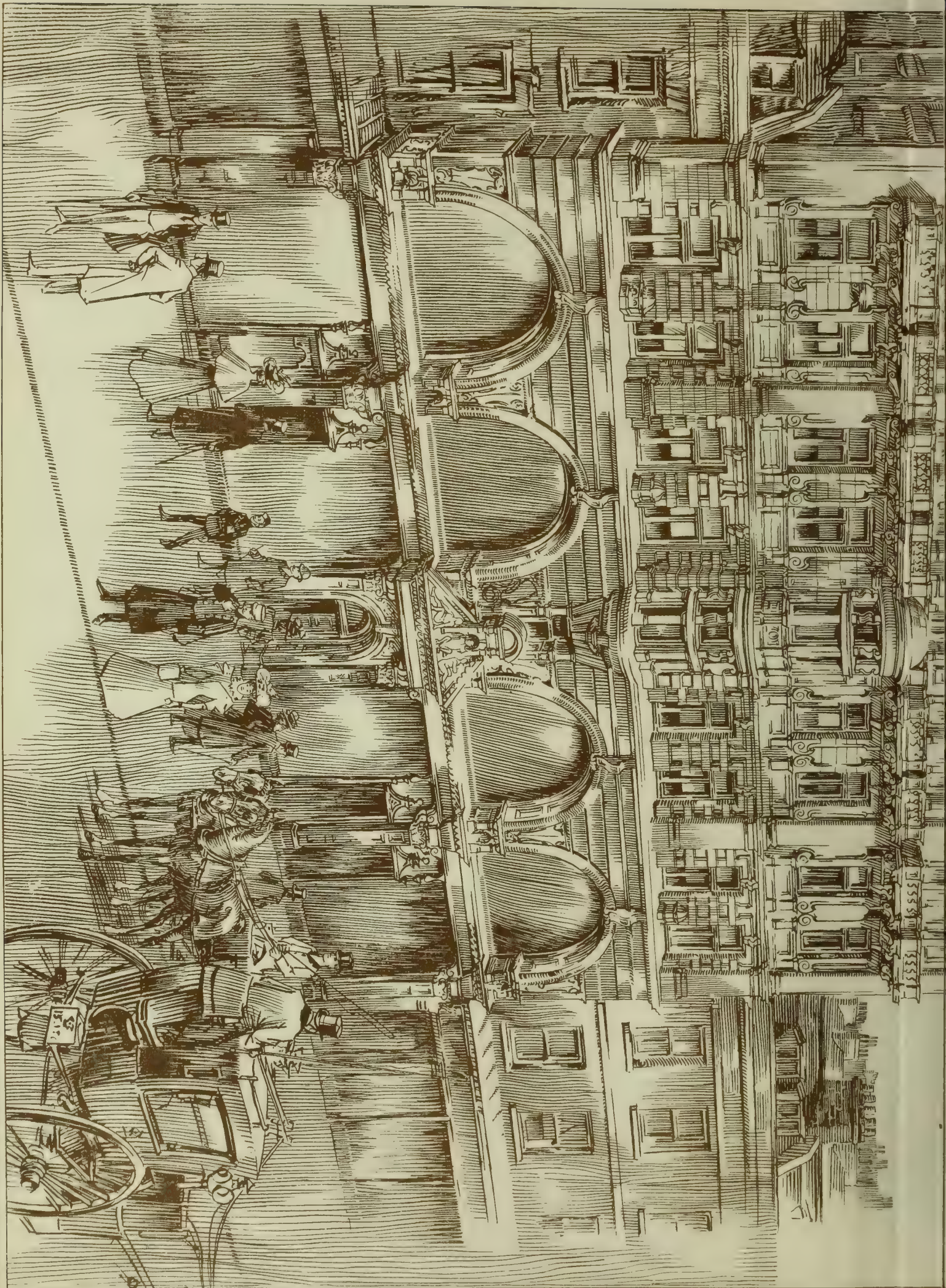

NOW IN COURSE OF ERECTION ON THE SITE OF HANOVER CHAPEL.

From "Landscape & Architecture" by W. G. Smith.

THE BUILDING DEWS, JAN. 7, 1895.

: PREMISES, REGENT STREET W  
FOR T. H. BROOKE HITCHING ESQ  
: 24 PORTLAND PLACE W.  
G. D. MARTIN. ARCHITECT

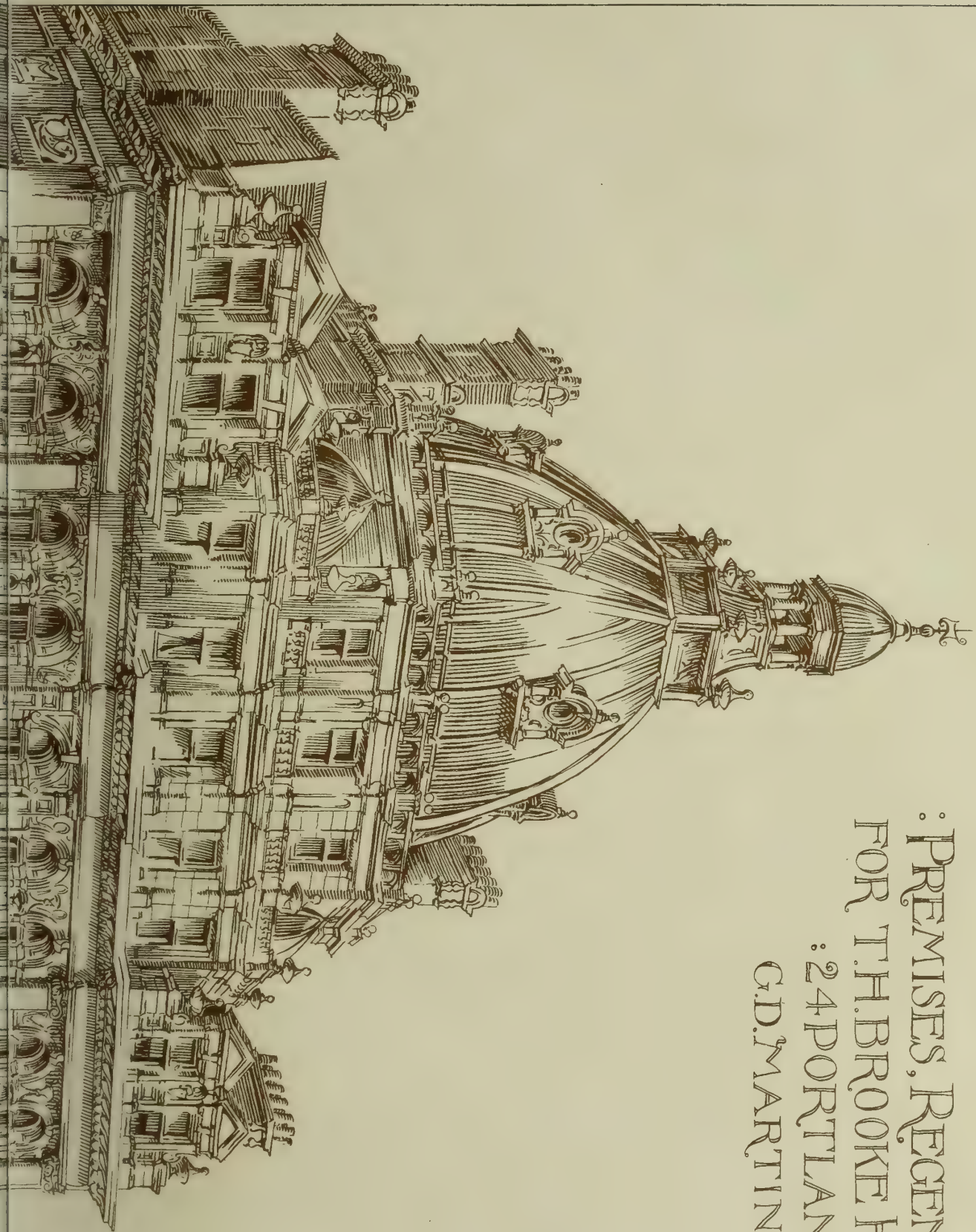





THE BUILDING PEWS, JAN. 7, 1895.

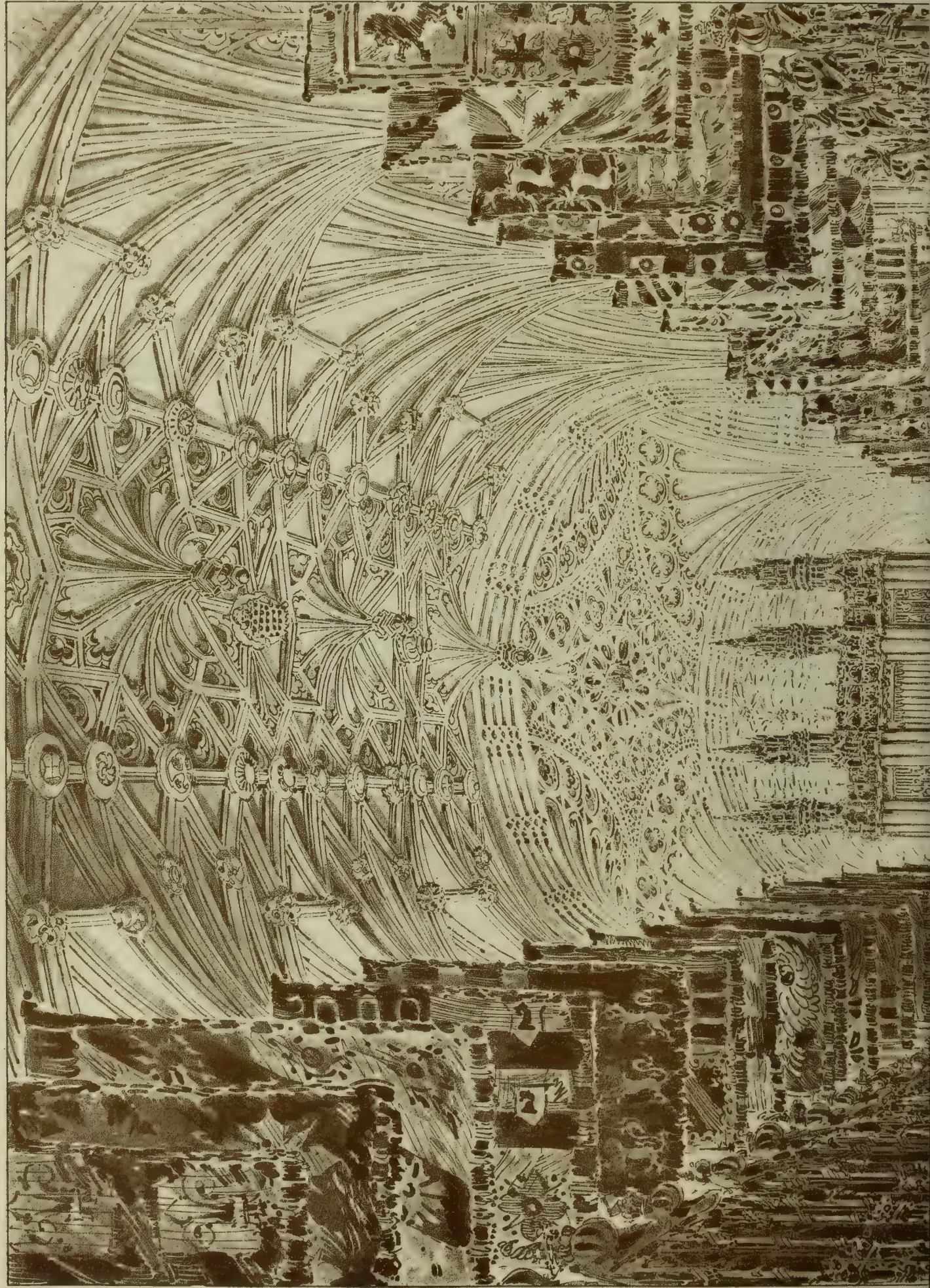



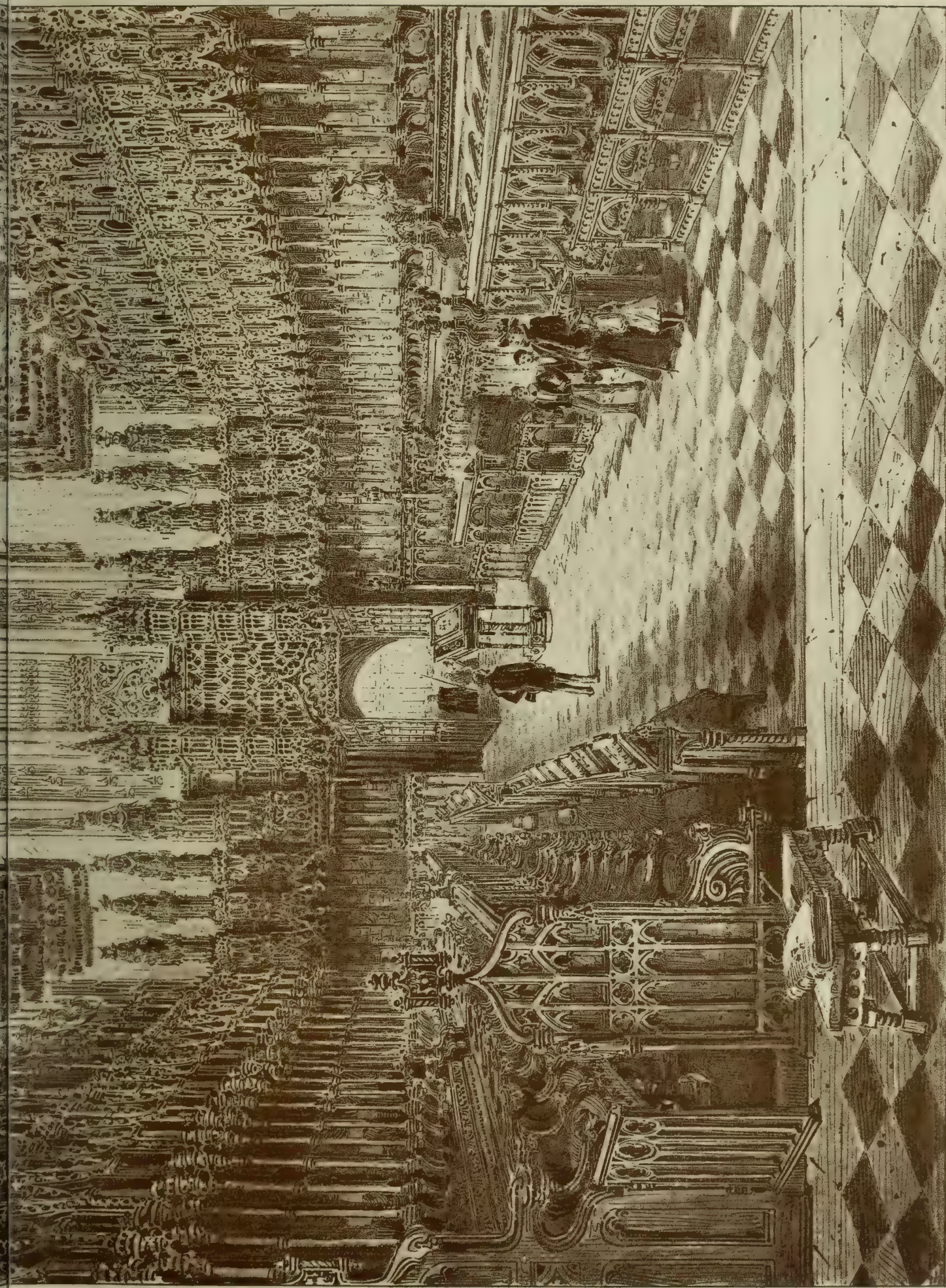
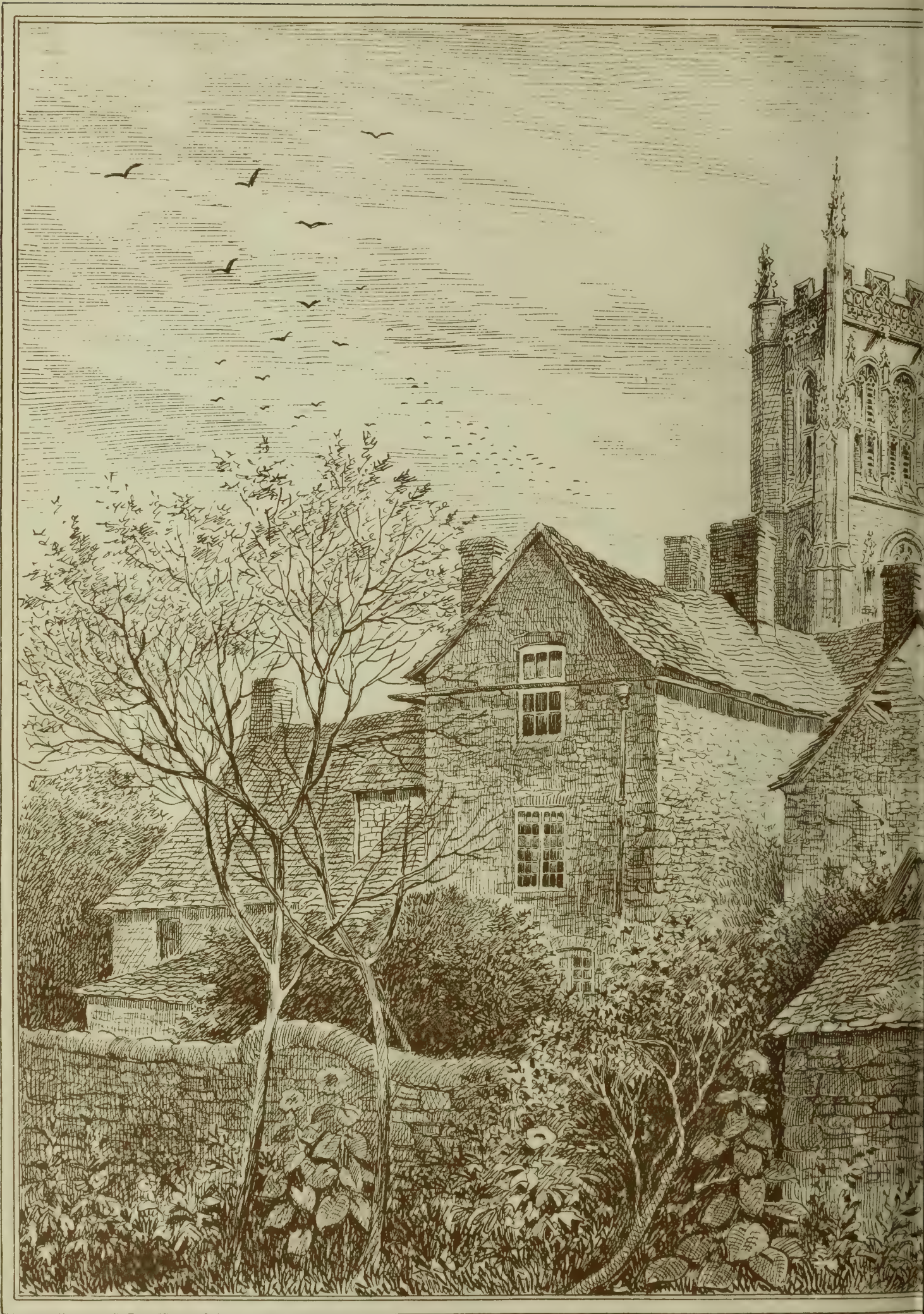

PHOTO-TINT BY JAMES AGNEW & SONS, LTD., 25, ABchurch Lane, LONDON, W. 1.

ST. GEORGE'S CHAPEL, WINDSOR. BY CHAS. BIRD.







BRUTON CHURCH - SOMERSETSHIRE.



DRAWN BY MAURICE B ADAMS FRIBA ARCHT

Photo Lithographed & Printed by James Akerman, 11, Queen's Lane, E.C.



## Building Intelligence.

**ISLINGTON.**—In the short space of four months Collins's Music Hall, Islington-green, has been rebuilt by Messrs. C. Dearing and Son, from plans and under the directions of Mr. Ernest E. A. Woodrow, A.R.I.B.A. The adoption of the cantilever system enabled the designer of the steelwork to make a single column suffice for the support of the balcony and gallery, so that the whole 1,800 seats have an uninterrupted view of the stage. This work was designed and erected by Messrs. T. Drew Bear, Perks, and Co., of 71A, Queen Victoria-street, E.C. The whole of the steelwork in plates and angles for the main girders are of English manufacture, and the girders themselves were made in London. The whole weight of steel in the construction of balcony and gallery is about 63 tons, and the load on the one column when the house is packed, as it was on Boxing Day, is estimated at about 200 tons.

**TRURO.**—A meeting of the general committee for the central technical schools for Cornwall (extension of the Passmore Edwards buildings) was held on Friday at Truro, Mr. Silvanus Trevail, F.R.I.B.A., chairman of the committee, presiding. It was reported that the city corporation had agreed to pay a considerable sum of money for the leasehold, and had been in possession as from Christmas Day. The trust deed, which was approved, provides for the management of the schools by a body of 30, composed of 10 members of the county council, 10 members of the Truro corporation, and 10 Truro citizens. The executive committee stated that when the tenders were gone into Mr. Colliver's was accepted, being much the lowest. Afterwards Mr. Colliver asked leave to amend his tender, owing to clerical errors. The secretary now stated that those errors represented a sum of £440. The chairman said the remarkable fact was that one of those errors was passed by an expert. The secretary explained that the mistakes were clearly made only in carrying out quantities and in casting up. The chairman added that the committee not only gave Mr. Colliver the chance of correcting clerical mistakes, but also Messrs. Clemens and Battershill, whose tender came next. The latter replied that they had made no mistake, but would take off £195 if certain work were excepted from the contract. There was no reduction of work whatever in Mr. Colliver's revised tender, which amounted to £6,540, against £7,178, the amount of the next tender. It was agreed to accept Mr. Colliver's altered tender. It was decided to have the contract signed at once, and to instruct the contractor to proceed with the work. Mr. Trevail is the architect of both the schools and the adjoining free library, the entire cost of both buildings being borne by Mr. J. Passmore Edwards. The schools are Tudor Renaissance in style, and were illustrated in the BUILDING NEWS for May 23, 1897.

At the University Chapel, King's College, Aberdeen, there was presented to the University on Monday, on behalf of the subscribers, a marble bust of the late Principal Pirie, executed by the French sculptor, M. Alfred Boucher.

A Bill to construct an underground electric railway from Charing Cross to Paddington has been deposited. The proposed railway will commence to the north of the Avenue Theatre at the southern end of Northumberland-avenue, and will terminate on the south side of James-street, near Paddington Station. In connection with this railway, it is proposed to construct a subway to the Great Western Railway Company's Paddington Station and another subway to Albert-terrace, Knightsbridge.

At Monday's meeting of the Stockport Board of Guardians an animated discussion took place respecting tenders for building new workhouse near Hazel Grove. Twelve months ago contractors were asked to send their names if willing to tender, and ten replied, the number being subsequently reduced to eight. A legal question arose, and no tenders were actually sent in. In consequence of the delay that has ensued, some guardians were in favour of throwing the competition open again. Others argued that such a course would be unfair to those who had already replied. The clerk said that fresh tenders would involve lithography to the amount of £200. It was retorted that if they could save £5,000 or £10,000 on the prospective outlay of £150,000 or £200,000 this would be only a fleabite. Eventually the board decided by 20 votes to eight to throw the competition open again.

## LEGAL INTELLIGENCE.

**ALLEGED JERRY-BUILDING IN BELFAST.**—At Belfast, on Dec. 29, William Hill, Belmont-avenue, a builder and contractor, who recently sought municipal honours, was summoned by the corporation for having, in the erection of new buildings at Strandtown, in the city of Belfast, used materials and workmanship which had been disapproved of, after notice in writing of such disapproval had been given. Evidence for the prosecution was given by Mr. Boyd, a building inspector, who stated that the mortar and other materials were of inferior quality, and that defendant persisted in its use after he complained. Mr. James Munroe, assistant city surveyor, and Mr. J. C. Bretland, city surveyor, also gave evidence. Objection was raised that the city surveyor had not acted under the advice of the corporation in the action, and the magistrates reserved their decision.

**DISTRICT SURVEYOR'S FEES FOR JUBILEE STANDS.**—Mr. J. G. Hornsby, 325, Strand, was summoned at Bow-street Police-court on Wednesday by Frederick W. Porter, district surveyor of Holborn and East Strand, to show cause why he should not pay £1 as a fee for surveying Jubilee seats at his establishment. Mr. W. H. Lees, deputy district surveyor, represented the complainant; Mr. Searle, solicitor, defended. Mr. Lees said the proceedings were taken under the London Building Act, Sections 54 and 57, which entitled surveyors to claim fees in a case of this kind. Sir James Vaughan said that might be so; but he must have proof that the money had been earned. Mr. Searle: I hold in my hand a receipt for £2 2s. my client has paid for surveying these seats, owing to the County Council not having done their duty. Mr. Lees: The £2 2s. they speak of was paid to the surveyor who prepared their drawings and made application to the County Council. Sir James Vaughan adjourned the case for evidence as to the work done by the district surveyor.

## CHIPS.

Mr. J. F. Stow, C.E., has been appointed engineer and surveyor to the urban district council of Bridlington, in succession to Mr. R. R. Brown, who held that office for eight years.

On Tuesday evening the Sunderland Fire Brigade were called out to an outbreak of fire in the old parish church of Monkwearmouth. It was found that the large gas-pipe, connecting the main with the meter, was in flames, and quickly melting away. The flames were soon extinguished, and but little actual damage was done. At the back of the partition dividing the meter from the vestry was a number of ancient documents to which great value is attached by antiquaries. The part of the church where the outbreak occurred is the very oldest portion, and dates back nearly 1,300 years, having been built by the Ven. Bede almost synchronically with the ancient church at Jarrow.

St. Barnabas Church, Ashley-road, Bristol, was reopened on Tuesday after internal improvements from plans by Mr. F. Bligh Bond. The choir was formerly on the same level as the congregation, and the Pennant flags continued from the aisle to the Communion steps. The alteration has raised the choir-stalls, separating them from the body of the church by a step and a low freestone screen, and the floor has been laid with tiles placed in pattern. An alteration has been made in the Communion steps, and a new kneeling rail provided. In addition, a new pulpit of Corsham stone, the panels of which are divided by columns of polished Devon marble, has been given. In the centre panel a figure of St. Barnabas has been carved.

The new Government buildings in Queen-street, Nottingham, including Post Office, Probate Office, Inland Revenue Office, &c., will be completed and ready for occupation in April or May next. One or two of the departments are already finished. At a meeting of the city council on Monday in committee it was decided to ask some member of the royal family to open the block of buildings. The mayor pointed out that the city had contributed nearly £20,000 in land to the cost of the buildings. Land which cost the corporation £11 per yard had been sold to the post office authorities for £4 to encourage the Government to concentrate the various departments in Nottingham in one spot.

By the Bill which has been deposited by the Midland Railway Company for the construction of railways from Royston to Huddersfield, Halifax, and Bradford, power is sought to raise £3,600,000. The proposed extensions will comprise just over thirty miles of new line, and will commence by a junction with the company's Derby to Leeds railway near Royston, passing through Thornhill to Huddersfield, and from thence to Halifax. From this proposed railway another line is projected, eleven miles in length, from Thornhill to Bradford, where it will join the company's Leeds and Bradford railway. A short line is also proposed to connect the Huddersfield section of this extension with the proposed extension to Bradford.

## Our Office Table.

The law of Illinois providing for the examination and licensing of architects is to be put in force at once, and examinations of candidates are to be held for the first time on January 11 and 12 (Tuesday and Wednesday in next week) at Chicago, and on June 21 and 22 at the University of Illinois, at Urbana. Applications for examination must be made upon the printed form provided by the Board of Examiners, and must be filed, with a fee of 15dol., at the office of the secretary of the Board, at Room 1,112, Chamber of Commerce Building, Chicago. If the application is made in due form, notice will be sent to the applicant of the time, place, and extent of the examination, which will occupy two days. If the candidate fails to pass the examination, his 15dol. will be returned to him; but if he passes, notice is sent to him, and he is required to pay a second fee of 25dol., on receipt of which his license is forwarded to him. The license is for life, but is subject to revocation, for cause, by the Board of Examiners, and an annual fee of 5dol. is to be paid, in July, during the time that the license is in force.

TOLSTOY'S new book on "Art" is said to be one of the most searching and enlightened works of criticism that has for many years proceeded from his pen. It opens with a description of the rehearsal of a modern opera, and proceeds to a minute and exhaustively descriptive analysis of the theories of modern criticism of all kinds of art—musical, dramatic, pictorial. Its conclusion points directly to the inadequacy and worthlessness of the conceptions embodied in them. Tolstoy declares finally for his own ideal. This is directly opposed to the æsthetic theory, which he traces from the Renaissance to modern times, and denounces as a degradation, or rather, a negation, of art. His criticism resembles in this respect that of Ruskin and Morris, but it has a more consecutive and historical basis. It is written with the gentle persuasiveness, the sensitive literary touch, and the great moral and critical force which mark Tolstoy's best work. A translation will be issued in this country by the Brotherhood Publishing Company.

A BILL will be promoted next session by which a company propose to extend the Victoria Embankment to Lambeth Bridge, with powers to reconstruct a good deal of the adjoining neighbourhood. The works to be authorised by the Bill are:—A new street 90ft. wide commencing at or near the Victoria Tower of the Houses of Parliament and terminating in the Horseferry-road at a point of 70 yards to the westward of the western end of Lambeth Bridge. A new street 60ft. wide commencing at the eastern end of Great Peter-street, Westminster, at a point opposite the north-eastern corner of the Gas Light and Coke Company's premises, and terminating by a junction with street No. 1 at a point 250 yards north of Horseferry-road. A new street 50ft. wide commencing by a junction with street No. 2 at a point 170 yards east of the commencement thereof, and terminating by a junction with Horseferry-road at a point of 150 yards, or thereabouts, from the south-east corner of the property of the Gas Light and Coke Company. A new street 40ft. wide commencing by a junction with street No. 1 at the south-western corner of the Victoria Tower-gardens, and terminating at the commencement of an embankment hereinafter described. A widening of Marsham-street on the eastern side from the eastern end of Great Peter-street to Horseferry-road. An embankment or river-wall with a roadway 40ft. wide along the foreshore of the Thames, commencing at or near the south-eastern corner of the Victoria Tower-gardens, adjoining the Houses of Parliament, and terminating at the western end of Lambeth Bridge. The capital proposed is one million, with borrowing powers.

At a meeting of the Auctioneers' Institute, held on Tuesday night in Chancery-lane, under the presidency of Mr. James F. Field, Mr. J. B. Matthews read a paper on the subject of the law relating to house and estate agents' commission, in which he said the law on this matter owed nothing to legislation. It depended entirely upon common law principles, which were to be found expressed in judgments which had been delivered by judges in various cases. The law relating to house and estate agents, in its main features, in no way differed from that relating to other

classes of agents, whose relations to their principals were regulated by the common law; but, nevertheless, house and estate agents formed a special class, whose rights and duties had so often come before the Courts for decision that it was possible to treat the present subject as a special one. The reader laid down from authorities the leading rules by which the right of house and estate agents to commission was governed, and illustrated these rules by reference to decided cases. Amongst the principle rules were:—That, where the remuneration of a house or estate agent was provided for by an express contract, no other contract which was inconsistent with the terms thereof, whether founded upon custom or otherwise, could be implied; but the right of the agent to remuneration was wholly dependent upon such express contract; that, where the agent's remuneration was not provided for by an express contract, the amount of the remuneration, and the conditions on which it became payable, must be ascertained from the usage or custom, if any, which had become established in house and estate agency business. Considering the vast multitude of transactions of sale effected through house and estate agents, he thought it was very creditable to auctioneers as a body that cases of alleged misconduct were extremely rare.

The Woolwich and District House Owners' and Ratepayers' Association and the Greenwich, Deptford, Lewisham, and District Property and House Owners' Society have joined in a memorial to the Local Government Board, in which they urge the following reasons why the existing law as to "new streets" should be altered: "The law is defective, and its amendment would be of advantage to house and property owners, local authorities, and the general public. The owners of houses in new streets should not be called upon to provide the cost of paving before the work has actually been executed; local authorities should be empowered to borrow money for the purpose, and the cost of the work should be ascertained by inviting tenders. The paving expenses should be made a charge upon the property, and should be repaid to the local authorities by the owners by instalments covering a period corresponding with the period of the loan. Much litigation and expense are caused by the difficulty of defining the expression 'new street.' The making-up of all new roads and streets should be entirely under the control of the local authority, who should receive greater discretionary powers with regard to the charges for site abutments."

In a short paragraph which appeared in our issue of a fortnight since, p. xvi., the first meeting was recorded of what purported to be the *Bath Stone Firms, Limited*, as having been held at the Board Pump Room, Bath; this should have been the *Hard Stone Firms, Limited*.

At the Hampshire Quarter Sessions at Winchester, on Tuesday, Mr. Temple Cooke applied for an order to close a road at Cowes near the Royal demesne of Osborne House, and in place of which the Queen had provided a more commodious and direct road. While the closing of the present road will be most convenient to the Queen and the privacy of the Royal island residence, the new road will be better in every way for the public, being wider and more suited for traffic. The Cowes authorities had consented to the proposed alteration, and the Court now granted the orders. The work will be completed at once.

The Glasgow Corporation have appointed Mr. W. A. Chamen, of Messrs. Crompton and Co., London, consulting and electric light engineers, to be electrical engineer for the city of Glasgow.

Trinity Congregational Church, Dewsbury, is undergoing alteration, and an enlargement, at a cost of £3,000. Its erection was commenced in 1868, from plans by Messrs. John Kirk and Sons, architects, of Dewsbury and Huddersfield, and completed in 1870. The cost of the building and fittings, exclusive of site, was about £3,000. An organ recess is being provided, in front of which will be a new pulpit in pitch pine. The electric light has been installed in church and schools, and a church parlour, ministers' and deacons' vestries, and class-rooms, with lavatories, &c., have been added. The schools are undergoing improvement. The architects are Messrs. Kirk and Sons.

Major-General H. Darley Crozier, R.E., held an inquiry, on Tuesday and Wednesday at Manchester, on behalf of the Local Government Board with reference to an application of the Manchester Corporation for power to borrow £180,000, of which £170,000 was needed for the purposes of sewerage and sewage disposal, and £10,000 for market purposes. There was no opposition.

#### MEETINGS FOR THE ENSUING WEEK.

MONDAY.—Surveyors' Institution. Adjourned Discussion on "The Royal Commissioners' Suggested Amendments to the Agricultural Holdings Act." 8 p.m.

Liverpool Architectural Society. "The Architecture of Michael Angelo," by Beresford Pite, F.R.I.B.A.

Bristol Society of Architects. "Decoration," by H. Dare Bryan, 8 p.m.

Leeds and Yorkshire Architectural Society. Annual Dinner.

WEDNESDAY.—St. Paul's Ecclesiastical Society. "The Black Chimere," by the Rev. Father Robinson, S.S.J.E. 7.30 p.m.

Edinburgh Architectural Association. "Abbeys and Cathedrals of Scotland," by P. McGregor Chalmers, M.A., of Glasgow. 8 p.m.

FRIDAY.—Architectural Association. "Composition in Regard to Public Buildings," by F. T. Baggallay, F.R.I.B.A. 7.30 p.m.

#### THE ARCHITECTURAL ASSOCIATION.

JANUARY 14th, ORDINARY GENERAL MEETING, at No. 9, Conduit-street, W., 7.30 p.m. Paper by Mr. F. T. BAGGALLAY, on "COMPOSITION."

E. HOWLEY SIM, } Hon. Secs.  
G. B. CARVILL, }

#### CHIPS.

A stained-glass window has been placed in Hornsey parish church. The glass was designed and executed by Mr. C. E. Kempe. The central figure is that of St. John the Baptist; on the one side is "The Baptism of our Lord in the Jordan," and on the other side the "Scene of our Lord Blessing Little Children."

The Isle of Thanet Rural District Council have instructed Messrs. Bailey Denton, Son, and Lawford to prepare plans for the sewerage of Minster.

The new superstructure of Moorgate-street Station, designed by Mr. Delissa Joseph, F.R.I.B.A., has now been completed, at a cost of about £18,000, the contractors being Messrs. J. Allen and Sons. The elevation, which is Classic in design, is executed in Portland stone, and occupies a frontage of about 155ft. to Moorfields, and of about 90ft. to Fore-street-avenue.

The urban district council of Eton have instructed Mr. E. Bailey Denton, M.Inst.C.E., to prepare plans for the erection of a new pumping station, pumping machinery, &c.

The condition of Liskeard church tower has exercised the minds of the vicar, the churchwardens, and the townsmen for some time. It was generally held that the condition of the tower was dangerous, but the Chancellor of Truro refused to grant a faculty for taking it down and rebuilding it. Under further pressure, and finding that the tower had been condemned as insecure by the borough surveyor, the Chancellor has now granted the faculty applied for.

On Thursday in last week, Col. W. Langton Coke, M.Inst.C.E., held an inquiry at Rushton, near Blackburn, into an application of the urban district council for sanction to the borrowing of £1,441 for works of public street improvements, £1,890 for private street improvements, £834 for sewerage and sewage disposal, £130 for a store-room and cart-shed, and £905 for culverts at the Holt and Norden Wood tips.

John Newman, a builder's foreman, of Enfield-terrace, Hendon, was charged on Saturday, at Marylebone Police-court, with maliciously breaking a plate-glass window, valued at £5, on the premises of a refreshment contractor in the Harrow-road. Having been served with tea, the prisoner suddenly, without any reason, swept the crockery off the table and hurled some broken pieces about the shop. He then rushed out and threw a large stone through the shop-window. The defendant was ordered to pay £4 10s. for the damage, and was fined 10s.

On Wednesday afternoon in last week a new parish room connected with St. Paul's Church, Stanklin, was opened by the Lady of the Manor (Mrs. White Popham) and the Attorney-General (Sir R. E. Webster, Q.C., M.P.). The room is 60ft. in length by 28ft. in width, Early English in style, and cost £1,070.

The directors of the Birkbeck Pier at Weston-super-Mare, the pavilion and concert-hall upon which structure were destroyed by fire last week, have decided to reinstate the buildings on improved lines, and have instructed Messrs. Hans Price and Wooler, architects, of Weston, to prepare plans. The building was insured for £1,700, but the damage done has greatly exceeded that amount.

A new Congregational church at the corner of Beech Grove-road and Westmoreland-road, Newcastle-on-Tyne, is approaching completion. The church is being erected from designs by Mr. Stephen Piper, architect, County Chambers, Newcastle, which were chosen in open competition. The contract was let to Mr. G. H. Mauchlen, Newcastle, for £6,950, exclusive of heating and electric lighting.

## Trade News.

### WAGES MOVEMENTS.

BRADFORD.—"The stone trade has," says the *Bradford Observer*, "been good during the past year, both locally and for the London trade, the latter being mostly for tooled flags and landings, and prices have hardened a little, but not much, during the year. The following may be taken as the ruling rates during the year, the prices varying according to quality of stone—viz., 3in. tooled flags, from 3s. 9d. to 4s. 2d. per square yard; 2½in. ditto, from 3s. 7d. to 4s.; 2in. ditto, from 2s. 8d. to 3s. 2d.; 3in. self-faced flags, from 3s. 2d. to 3s. 8d. per square yard; 2½in. ditto, from 2s. 6d. to 3s. 2d.; 2in. ditto, from 2s. to 2s. 4d. per square yard; ashlar, 1s. 6d. to 2s. per cubic foot. Outside wall stones, from 44s. to 54s. per rood; inside ditto, from 20s. to 24s.; pitch-faced ditto, from 42s. to 50s. per rood. Bricks, 25s. to 30s. per thousand at the works. Quarryowners complain of the little profit left on a year's turnover, owing to the immense wear and tear involved in the heavy stone trade."

MANCHESTER.—The Baths and Washhouses Committee of the Manchester Corporation have received a communication from the secretary of the United Operative Plumbers' Association of Great Britain and Ireland in which regret is expressed that the baths and washhouses committee cannot see their way to employ plumbers to do certain work at the baths, and that in consequence "it will be impossible for any member of the association through the United Kingdom to do any work, either new, alterations, or jobbing, for the baths committee until such decision is revoked." The Operative Plumbers' Association object to the pipe fitting (mostly iron pipes) and repairs at the baths under the control of the committee being done by engineers and other permanent employes of the baths committee, generally in their spare time. The committee, having considered this warning, have decided to continue as heretofore.



### BILLS OF QUANTITIES, PLANS, &c.

Lithographed in best style and with great expedition by  
**PARTRIDGE & COOPER,**  
ARCHITECTS' AND SURVEYORS' LITHOGRAPHERS,  
191 & 192, Fleet St., and 1 & 2, Chancery Lane,  
London, E.C.  
Special Prices quoted for Large Jobs.  
LIBERAL DISCOUNTS ACCORDING TO ARRANGEMENT.

## PILKINGTON & CO.

(ESTABLISHED 1838),  
MONUMENT CHAMBERS,  
KING WILLIAM STREET, LONDON, E.C.

## POLONCEAU ASPHALTE

### Patent Asphalte and Felt Roofing.

ACID-RESISTING ASPHALTE.  
WHITE SILICA PAVING.  
**SEYSEL ASPHALTE.**

## FAMBRINI & DANIELS,

MANUFACTURERS OF IMPERISHABLE CONCRETE  
MASONRY FOR  
CORNICES, STRING-COURSES,  
MODELLED PANELS, AND EVERY  
STONE-WORK REQUISITE.

LANDINGS and Plain or Moulded and Mitre  
STEPS, durable throughout.  
WORKS AND OFFICES: LINGOLN.

## HAM HILL STONE. DOULTING STONE.

THE HAM HILL & DOULTING  
STONE CO.

Incorporating THE HAM HILL STONE CO. and C. TRASK and  
SONS (THE DOULTING STONE CO.)  
Chief Office: NORTON, STOKE-UNDER-HAM, SOMERSET.  
London Agent: Mr. E. A. WILLIAMS, 18, CRAVEN STREET, STRAND



LIST OF COMPETITIONS OPEN.

Crich—Water-Supply Scheme (3,100 population)	15 Guineas, 5 Guineas	Joseph Pym, Clerk, Belper	Jan. 8
Antrim—Dispensary (limit £750)		John Bullock, Hon. Sec., Bells-grove, Crumlin	" 13
Carlton, Victoria—Children's Hospital	£100, £50, £25	J. Nicholson, Hon. Sec., Pelham-street, Carlton, Australia	" 30
Leicester—Motor Refuse Carts	Corporation	E. G. Mawbey, Borough Engineer, Leicester	" 31
Rugby—Public Work, Cattle Market		T. M. Wratistaw, Clerk, Rugby	Feb. 1
Eastleigh—Public Offices	50s. (merged), 20s.	Hy. White, Clerk, U.D.C., 19, St. Peter's-street, Winchester	" 7
Wolverhampton—Motor Vans	Public Works Committee	J. W. Bradley, C.E., Borough Engineer, Town Hall, Wolverhampton	" 7
Barrow-in-Furness—Technical Schools	£50 (merged), £20	The Town Clerk, Town Hall, Barrow-in-Furness	" 14
Port Elizabeth—Free Library (Assessors, Sir F. Blaine and R. H. Hammersley-Human—£22,000 limit)	100 Guineas, 50 Guineas	G. Oettle, Librarian, Port Elizabeth, S.A.	" 15
New York—Sun Dial (Plaster Model)	500dol., 250dol.	Sec. National Sculpture Soc., 215, West 57th-street, New York	" 28
Newcastle-on-Tyne—New Infirmary (local Architects)	(No first) £150, £100, £50	Secretary Building Committee, Newcastle	Mar. 1
Berwick-on-Tweed—Police-Station (£5,000 limit)	Commission or £50, £25	R. Weddell, Town Clerk, Berwick-on-Tweed	" 14
Belper—Sewage Disposal Schemes	50 Guineas, 25 Guineas	Joseph Pym, Clerk, Belper	May 1

LIST OF TENDERS OPEN.

BUILDINGS.

Kingussie—Warehouse and House, Tomatin Distillery		Alexander Mackenzie, Architect, Kingussie	Jan. 8
Carlton—Wesleyan Chapel and School		W. Johnson, Architect, Howden	" 8
Shoeburyness—Victoria Hall		Rev. E. A. Causton, the Rectory, Shoeburyness	" 8
Llanhilleth—Hotel, with Stables		C. Telford Evans, Architect, 8, Queen-street, Cardiff	" 8
Kirkbride—House, &c.		E. Hill, Grocer, Kirkbride	" 8
Manchester—Twenty-six Three-Storey Tenement Buildings and Two Shops, Pott-street and Caroline-street	Sanitary Committee	City Surveyor, Town Hall, Manchester	" 10
Ben Rhydding—Residence		Empsall and Clarkson, Architects, 7, Exchange, Bradford	" 10
Blackpool—Mineral Water Manufactory	Blackpool Mineral Water Supply	Garlick and Sykes, Architects, 22, Birley-street, Blackpool	" 10
Belfast—Detached Villa, Knockbreda Park		J. G. Lindsay, Architect, 6, Chichester-street, Belfast	" 10
Stratford-on-Avon—Additions to Farmhouse	Corporation	Borough Surveyor, Stratford-on-Avon	" 10
Kirkbride—House	School Board	E. Hill, Grocer, Kirkbride	" 10
Kyo—Alteration and Addition to West Kyo School		G. T. Wilson, Architect, 121, Durham-road, Blackhill	" 10
Prizinghall—Pair Semi-Detached Villas, Heaton-grove		Isitt, Adkin, and Hill, Architects, Prudential Buildings, Bradford	" 10
Ware—Removing Iron Hospital Buildings to Hertford	Joint Hospital Authorities	G. W. Gisby, Clerk, Town Hall, Ware	" 10
Sheffield—Pair of Villas, Hardwick Crescent		Flookton and Gibbs, Architects, 15, St. James's-row, Sheffield	" 10
Bez—Villa	J. P. Martin	W. H. Stanley, Architect, Trowbridge	" 10
Bedford—Offices and Storerooms at Electricity Works		T. S. Porter, Town Clerk, Town Hall, Bedford	" 10
Manchester—Thirteen Shops, Oldham-road	Sanitary Committee	City Surveyor, Town Hall, Manchester	" 10
Belfast—Two Semi-Detached Villas		J. G. Lindsay, Architect, 6, Chichester-street, Belfast	" 10
Hull—Fitting-up Flour Mill, Garnson Side	Triticine, Limited, Castleford	Gelder and Kitchen, Architects, 76, Lowgate, Hull	" 10
New Elgin—House, Rothes-road	Commissioners of Woods and Forests	James Jamieson, Architect, Elgin	" 10
Lyndhurst—Additions to Holmfield		Hon. G. Lascelles, Queen's House, Lyndhurst	" 10
Londonderry—Four Houses, Brook-street	Urban District Council	J. P. McGrath, Architect, Foyle-street, Londonderry	" 11
Aberborn—Double Cottage		Reid and Wittet, Architects, Architects, Elgin	" 11
Radcliffe—Public Baths		J. Sharples, Clerk, Radcliffe	" 11
Wallsend—Six Houses	Board of Guardians	Secretary, Industrial Co-operative Society, Wallsend	" 11
Barrow-in-Furness—Laundry Extension		J. Y. McIntosh, Architect, Cornwallis-street, Barrow	" 12
Hull—Congregational Church and School, Prince's-avenue	W. G. Welch	W. H. Bingley, Architect, Custom House-buildings, Hull	" 12
Hampson, Lancs—Farmhouse		Austin and Paley, Architects, Lancaster	" 12
Ryther—Church Restoration	Sanitary Committee	C. Hodgson Fowler, F.S.A., Architect, The College, Durham	" 12
Leicester—Raising Roof of Boiler-House at Refuse Destructor Works		E. George Mawbey, C.E., Borough Surveyor, Town Hall, Leicester	" 13
Burley-in-Wharfedale—National School (for 500)	Guardians of Billericay Union	Ed. C. Brooke, Architect, 4, Huddersfield-road, Brighouse	" 13
Billericay—New Infirmary, Casual Wards, &c., at Workhouse		C. Edgar Lewis, Clerk, Brentwood	" 13
New Quay—Headland Hotel	Guardians	Silvanus Treval, F.R.I.B.A., Architect, Truro	" 13
Dewsbury—House for Caretaker at Registry Office	St. Olave's Board of Guardians	Joseph Peace, Clerk, Union Offices, Wellington-street, Dewsbury	" 13
Chippenham—Two Houses and Shops, New-road	Admiralty	Thomas Holloway, Architect, Chippenham	" 13
Ladywell, S.E.—Workhouse for 800 Persons, Slagrove Farm	Commissioners	E. Pitts Fenton, Clerk, 30, Tanner-street, S.E.	" 13
Bradford—Business Premises, North-parade		Walker and Collinson, Architects, 227, Swan-arcade, Bradford	" 13
Portland Bill—Ten Coastguardmen's Dwellings		Director of Works Department, 21, Northumberland-avenue, W.	" 14
Kingstown—Municipal Offices, George's-place	Committee	John Donnelly, Town Clerk, Town Hall, Kingstown	" 14
Harwich—Additions to Schoolroom, Pulpit, Reseating, &c. at Congregational Church	M. N. Carlisle	J. W. Start, Architect, Colchester	" 15
Workington—Villas	Board of Guardians	W. G. Scott and Co., Architects, Workington	" 15
Archiestown—Alterations, Two Houses	Late Margaret Newby's Trustees	D. Maclean, Blacksmith, Archiestown	" 15
Warminster—Vagrant Wards	Trustees of the Headborough Estate	A. F. Long, M.S.A., Warminster	" 15
Tariff—Free Church	Dartford Rural District Council	D. and J. R. McMillan, Architects, 211, Union-street, Aberdeen	" 17
Ireleth—Three Cottages	Town Council	R. P. Nelson, M.S.A., Surveyor, Broughton-in-Furness	" 17
Ryde, I.W.—Additions to Infirmary	Guardians of Hackney Union	J. Fardell, Hon. Sec., Market-street, Ryde	" 17
East Dereham—Town Hall	Corporation	Chas. B. L. Norgate, Clerk to Headborough Trustees, E. Dereham	" 17
Elgin—Diamond Jubilee Cottages, Maisondien		A. and W. Reid and Wittet, Architects, Elgin	" 17
Stone—Chapels and Caretaker's House at New Cemetery		J. C. Hayward, Clerk, Sessions House, Darford	" 17
Brynmawr—County School		John Thomas, Clerk, 194, King-street, Brynmawr	" 17
Dover—Boiler-house at Sea Baths, Marine Parade		E. Wollaston Knockor, Town Clerk, Castle Hill House, Dover	" 18
Llanfair Caereinion—County Schools		W. Story, Clerk to the Governors, Llanfair, Welshpool	" 19
Homerton, N.E.—Alterations to Ward No. 23 at Union Infirmary		Frank R. Coles, Clerk, Homerton, N.E.	" 19
Leeds—Bridge over Aire at South Accommodation-road		The City Engineer, Municipal Buildings, Leeds	" 19
Huddersfield—Alterations and Additions to Shop Premises, New-street and Market-place		John Kirk and Sons, Architects, Huddersfield	" 20
East Dulwich, S.E.—Repairs to Infirmary, East Dulwich-grove		G. D. Stevenson, Architect, 13, King-street, Cheapside, E.C.	" 20
Glossop—Pavilion		R. G. Hawke, Architect, Bank Chambers, Glossop	" 20
Flushing, Cornwall—School Buildings		F. F. Savage, Flushing Vicarage	" 22
Boat of Garten—Villa		D. Macpherson, Boat of Garten	" 22
Lochmaben—Alterations to Free Church		T. E. Watson, National Bank, Lochmaben	" 22
Cullingworth—Thirteen Houses		David Weatherhead, Architect, 55, Devonshire-street, Keighley	" 23
Epsom—Temporary Structures (for 700 patients and staff), Horton Manor Estate	London County Council	R. W. Partridge, Clerk Asylums Committee, 21, Whitehall-pl., S.W.	" 24
Swindon—Washing Baths	G.W.E. Medical Fund Society	The Secretary, Swindon	" 24
Llanwrst—School for Girls, and Alterations and Additions to Boys' Schools, at Llanwrst County School	Commissioners of H.M. Works	Peter McIntyre, Clerk to the Governors, Llanwrst	" 25
Winchester—Enlargement of Post Office	Corporation	Hon. Reginald B. Brett, Secretary, 12, Whitehall-place, S.W.	" 25
Bootle—Lodge, Derby Park	Lancashire and Yorkshire Ry. Co.	J. H. Farnar, Town Clerk, Bootle	" 25
Hoghton—Passenger Station and Footbridge	Markets Committee	C. W. Bayley, Secretary, Hunt's Bank, Manchester	" 25
Burnley—Extension of Electric Light Station	London County Council	G. H. Pickles, A.M.I.C.E., Town Hall, Burnley	" 25
Leeds—Dead Meat Market, New York-street	Guardians of Holborn Union	Jno. Harrison, Town Clerk, Town Hall, Leeds	" 25
Bethnal Green, E.—Block of Dwellings on Boundary-st. Area	Guardians of Bromley Union	T. Bell, Clerk, Council Offices, Spring-gardens, S.W.	" 25
Mitcham—Visitors' Room and Engineer's House at Schools	Corporation	C. E. Vaughan, F.R.I.B.A., 25, Lower Arcade, Strand, W.C.	" 26
Farnborough—Extension of Workhouse Infirmary	London County Council	E. Gordon Mullen, Clerk, 96, High-street, Bromley	" 27
Wolverhampton—Shelter, East Park	London County Council	W. Bradley, Board Engineer, Wolverhampton	" 29
Tooting Common—Refreshment House	London County Council	T. Bell, Clerk, Council Offices, Spring-gardens, S.W.	" 31
Camberwell—Refreshment House, Myatt's Fields	Corporation	T. Bell, Clerk, Council Offices, Spring-gardens, S.W.	" 31
Southampton—Isolation Hospital, Mousehole-lane, Millbrook	Governors of Grammar School	George B. Nalder, Town Clerk, Municipal Offices, Southampton	Feb. 1
Dudley—Grammar School and Master's House, St. James's-rd.	Festiniog Board of Guardians	Albert Morton, Clerk to the Governors, 15, Birmingham-rd., Dudley	" 1
Ferrylundreath—Vagrant Wards at Workhouse	St. Mary Islington Guardians	Thomas Roberts, Clerk, Portmadoc	" 4
Highgate Hill, N.—Infirmary (for 800 patients), &c.	Shaws, Bryant, and Co.	Edwin Davey, Clerk, St. John's-road, Upper Holloway, N.	" 10
Colchester—Business Premises, Long Wyre-street		Chas. E. Butcher, Architect, 3, Queen-street, Colchester	"
Edmonton, N.—Fifty Cottages		Architect, care of Fuller and Jackson, 11, Grocer's Hall-court, E.C.	"
Stratford—Laundry, Chester-road	Rev. Francis G. Jones, Vicar	Johnstone Brothers, Architects, 39, Lowther-street, Carlisle	"
Llandudno—Completion of Duke of Clarence Memorial Church	Bury Brewery Company	J. Oldrid Scott, Architect, 35, Spring-gardens, London, S.W.	"
Skegness—Two Boarding Houses		C. Nelson Holloway, Architect, Angel-row, Nottingham	"
Bury—Five Dwelling Houses at Littlewood Cross		Thos. Nuttall, C.E., Architect, &c., 20, Market-street, Bury, Lancs.	"
Nottingham—Workshop and Offices, Pepper-street		C. Nelson Holloway, Architect, Angel-row, Nottingham	"
Oakthorpe—Warehouse, Providence Mills		Judson and Moore, Architects, York Chambers, Keighley	"
Pontefract—Reconstruction of Inn	Brice, Butler, and Lee	Tennant and Bagley, Architects, Pontefract	"
Padstow—Hotel		Crickmay and Sons, Architects, 13, Victoria-street, Westminster	"

BUILDINGS—contim e l.

Table listing building projects and their architects. Includes entries for Londonderry, Bury, Bradford, Crawcrook, Cudworth, Belfast, Coventry, Cardiff, Craigellachie, Crossgates, Church Stretton, Dromahair, Swansea, Shirebrook, Liandrinod Wells, Leeds, Cete, Island of Innisbofin, Burnley, Harpers-lane, Rawmarsh Hill, Cashelner, Jonathan Hamer, West Wylam & Prudhoe Co-op. Soc., Coventry Co-operative Society, Bible Christian Methodist Church, Wm. Conn, Dromahair Dairying Society, Pleaseley School Board, Robert Hudson, Messrs. Grimshaw, Burnley, R. H. McElwee and Co., Architects, 9, Carlisle-road, Londonderry, D. Hardman, Architect, Silver-street, Bury, Lancs., Albert House, Unicorn-passage, Bradford, Yorks., W. Dixon, Architect, St. John-street, Newcastle-upon-Tyne, Hutchinson's Provision Store, Cudworth, H. T. Fulton, 91, Donegal-street, Belfast, George & Isaac Steane, Architects, 22, Little Park-street, Coventry, T. C. Nicholson, F.R.I.B.A., F.S.I., Architect, Blaydon-on-Tyne, Veal and Sant, Architects, 6, Arcade Chambers, High-street, Cardiff, Dunn and Finlay, Architects, 35, Frederick-street, Edinburgh, William Walker, Albert Mout, Horforth, John R. Withers, Architect, Shrewsbury, John O'Rourke, Secretary, Dromahair, Margrave and Peacock, Architects, Metal Exchange, Swansea, Frederick Ball, Architect, 23, King-street, Nottingham, A. B. and W. Scott Deakin, Architects, Shrewsbury, J. W. Thackray, Architect, 3, Rossington-pl., Gathorne-ter, Leeds, The Municipal Authorities, Cete, France, Rev. James M'Fadden, P.P., Glens, Gortahork, Charles Parsons, 9, Grinshaw-street, Burnley, J. Platts, Architect, Old Bank Buildings, Rotherham, Rev. Jas. McFadden, P.P., Glens, Gortahork.

ENGINEERING.

Table listing engineering projects and their engineers. Includes entries for Bundoran, Dunmanway, Athens, Bedford, Swansea, Cowbridge, Boodle, St. Cyrus, Dublin, Begles, Radcliffe, Worthing, Sunderland, Rathdrum, Leeds, Darwen, Gloucester, Kirkcaldy, Fenoced, Tarragona, Skirlaugh, Navan, Nantes, Blair Atholl, Castlebar, Belgrano, Oudshoorn, Dover, Birkenhead, Guipuzcoa, Pernambuco, Madras, Guardians of Ballyshannon Union, Guardians, Electric Light Committee, Urban Sanitary Authority, Rural District Council, Corporation, General Prisons Board of Ireland, Urban District Council, Corporation, Guardians, Gas Committee, Electricity Supply Committee, Waterworks Commissioners, Glamorgan County Council, Spanish Government, Guardians of Skirlaugh Union, Town Commissioners, Highland Railway Co., Gas Co., Argentine Government, Cape Government, Town Council, Joint Committee, William D. Sang, C.E., Kirkcaldy, T. Mansel Franklin, Clerk, Westgate-street, Cardiff, Office of Civil Governor, Tarragona, C. W. Hobson, Clerk, Newbegin, Beverley, J. H. H. Swiney, M.I.C.E., Avenue Chambers, Belfast, Prefect of the Province of the Isere, Nantes, Wm. Gowenlock, Secretary, Inverness, J. Sheridan, Secretary, Castlebar, Co. Mayo, Minister for Commerce, Buenos Ayres, Agent-General, 112, Victoria-street, S.W., E. W. Knocker, Town Clerk, Dover, A. E. Bolton, Secretary, Paddington Station, W., Commercial Department of Foreign Office, Whitehall, S.W., Brazilian Ministry of Public Works, Rio de Janeiro, Chief Engineer for Irrigation, Madras.

FENCING AND WALLS.

Table listing fencing and wall projects. Includes entries for Willerden, Kent, Willenhall, Lazonby, Urban District Council, Dartford Rural District Council, Urban District Council, S. W. Ball, Clerk, Dyne-road, Kilburn, J. C. Hayward, Clerk, Sessions House, Dartford, Chas. J. Jenkin, Engineer, Council Office, Willenhall, E. James, Silloth.

FURNITURE AND FITTINGS.

Table listing furniture and fittings projects. Includes entries for Claremorris, Liverpool, J. J. Shanly, Clerk, Claremorris, H. J. Haggart, Vestry Clerk, Parish Offices, Brownlow Hill, Liverpool.

PAINTING.

Table listing painting projects. Includes entries for Glasgow, Darwen, Withington, Blackheath, Ravenscourt Park, London County Council, A. R. McDonald, City Engineer, Glasgow, C. Costellen, Town Clerk, Darwen, D. S. Bloomfield, Clerk, All Saints, Manchester, T. Bell, Clerk, Council Offices, Spring-gardens, S.W.

ROADS AND STREETS.

Table listing roads and streets projects. Includes entries for Wakefield, Slough, Dartmouth, Budleigh Salterton, Aberdeen, Leamington, Moss Side, Southgate, Annfield Plain, Cannock, Preston, Stanley, Spennymoor, Fulham, Homerton, Dunoon, Cardiff, Sparkhill, The Town Clerk, Town Hall, Wakefield, G. H. Charsley, Clerk, 11, Mackenzie-street, Slough, T. O. Veale, Surveyor, Dartmouth, E. G. Warren, M.S.A., Commercial Chambers, Exeter, William Dyack, Borough Surveyor, Town House, Aberdeen, Consett Passman, Town Clerk, Leamington, W. R. Acton, C.E., Surveyor, Moss-lane East, W. M. Ellenor, Clerk, Palmer's Green, N., T. J. Trowsdale, Surveyor, Annfield Plain, C. A. Loxton, Clerk, Cannock, Borough Engineer, Town Hall, Preston, John Geo. Ridley, Clerk, Stanley, R.S.O., Fred Badcock, Clerk, 3, James-street, Spennymoor, Charles Botterill, Surveyor, Town Hall, Walham Green, S.W., F. R. Coles, Clerk, Homerton, N.E., C. J. M. Macintosh, Burgh Surveyor, Dunoon, Veal and Sant, Architects, 5, Arcade Chambers, High-st., Cardiff, W. Roberts, Land Agent, 37, Waterloo-street, Manchester.

SANITARY.

Table listing sanitary projects. Includes entries for Kingussie, Winchmore Hill, Kingston-upon-Thames, Felixstowe, Hayes, Sherburn, Ballachulish, Stanley, Coventry, Witham, Newmarket, Hendon, Coimbra, Macclesfield, New Brompton, Southgate Urban District Council, Drainage Committee, Urban District Council, Uxbridge Urban District Council, Durham Rural District Council, Lorn District Committee, Urban District Council, Corporation, S. Metropolitan School Managers, Urban District Council, Urban District Council, Government, Rural District Council, Gillingham Urban District Council, Alexander Mackenzie, C.E., Kingussie, W. M. Ellenor, Clerk, Palmer's Green, N., Town Clerk, Clatterton House, Kingston-upon-Thames, Geo. S. Horton, Surveyor, Town Hall, Felixstowe, Charles Woodbridge, Clerk, 38, High-street, Uxbridge, William Lisle, Clerk, 33, Saddler-street, Durham, J. D. Sutherland, Clerk, Royal Bank Buildings, Oban, J. G. Ridley, Clerk, Stanley, R.S.O., Lewis Beard, Town Clerk, 10, Hay-lane, Coventry, Henry Burgess, Clerk to Managers, Sutton, Surrey, Sidney J. Ennion, Clerk, Newmarket, Henry Humphris, Clerk, Public Offices, Hendon, N.W., Department of Public Works, Lisbon, J. F. May, Clerk, Churchside, Macclesfield, F. C. Boucher, Clerk, New Brompton, Kent.

STEEL AND IRON.

Table listing steel and iron projects. Includes entries for Leicester, London, Harrogate, London, Hull, Leeds, Gas and Electric Lighting Committee, Assam Bengal Railway Co., Corporation, Nizam's State Railways Co., Corporation, Alfred Colson, M.I.C.E., Engineer, Millstone-lane, Leicester, F. A. Lyall, Secretary, 55, Bishopsgate-street Within, E.C., Samuel Stead, Borough Surveyor, Municipal Offices, Harrogate, The Managing Director, Winchester House, 59, Old Broad-st., E.C., F. J. Bancroft, Water Engineer, Town Hall, Hull, The City Engineer's Office, Municipal Buildings.

## THE BUILDING NEWS

AND ENGINEERING JOURNAL.

VOL. LXXIV.—No. 2245.

FRIDAY, JANUARY 14, 1895.

## PROFESSIONAL GRIEVANCES.

THE architect is a long-suffering individual, and receives a great many more insults than falls to the lot of other professional men. His taste and art culture are called into question by Mr. Brown or Mr. Jones, and if he is at all sensitive about these points, his life is not an enviable one; but if he is fairly thick-skinned or retaliative in disposition, he can manage to give back as many kicks as he receives. When a client disapproves of a design, finds fault with the style or the elevations, the highly-strung artist is wounded to the core, for it is upon this part of the design that his chief reputation rests. It is like telling a painter that his composition is bad, or a musician that his performance is a failure; and yet it is one of the commonest disappointments the architect is called upon to suffer. No client, in whatever position he may move, hesitates to criticise the design of his architect, or to offer objections to this or that feature; while he may have the good manners to wrap it up in the general compliment, "That the design is very nice as a whole, &c.," as if he placed his taste and judgment on design on a level with that of his architect. When will the average lay mind learn that it is for this part of the work of the architect that he employs a professional man? Imagine a buyer of a picture or a sitter to a portrait questioning the skill and correctness of the artist! We have often thought it strange that a client should dictate to the architect of his house how it should be planned, when that was the very reason he came to seek a professional man! While the design is still in the air, the client leaves it entirely to his adviser; but directly it assumes a form on paper, then it is that all kinds of suggestions and alterations are made. Brown has seen a better plan somewhere; he wants something like Mr. So-and-So has erected; he likes half-timbered gables, or a square-shaped house. As if all these ideas could not have been thrown out before the plans and elevations had been prepared! The very fact they are not hinted shows that the ordinary client has no ideas of his own, and nothing to base them on until the design appears in tangible shape. After the design is made on paper he begins to compare it with other buildings, and thinks he can improve upon it. So with competition committees: they begin to criticise and discuss directly they get the plans in; the fussy committee-man compares A's design with those of B and C, as if his opinion was conclusive. In short, until the architect puts his own ideas into order and shape, no one else has any to offer; in fact, the client looks upon the design as a mere drawing that can be altered to suit his taste, and that has been expressly prepared for his approval. The grievance begins here. The client imagines that, as he employs, he can decide; he engages the architect to prepare designs for his approval, just as he looks to his tailor to show him patterns. The two things are not on all fours; the garment has to fit the customer, but the building has to be designed to accommodate at least the wants of a family, if not of a future generation of occupants. Everybody thinks he has taste, and can decide upon matters of style, of elevation, and decoration; but if this assumption was conceded, we should have so many variations that the architecture of our cities would be a very heterogeneous medley of ideas and of all stages of cultured and

uncultured taste. A great deal, of course, depends on the way an architect goes to work, how he meets his client, and draws out from him his ideas and predilections. Some in the profession are skilled in this tact; they discuss the question of design with their employer, ask him if he has any preferences, if he can point to any building or design he likes, and by this means they can obtain some notion of their client's views, and then can discuss with him why these views are wrong, or point out their weakness. By so discussing the matter, the client is taken into confidence, and when he receives the design, he is much less disposed to find fault than he would have done if his opinions were not canvassed. We believe a great deal of unnecessary friction might be avoided if the architect talked the matter over, instead of thrusting upon him a design without consultation.

But, perhaps, the hardest blow is for an architect to have to "father" a design which is really his client's or his client's wife's; to get the credit for some monstrosity which he has been helpless to avert. Shorn of one feature after another, altered to suit the taste of someone who wishes to imitate a palace or a riverside bungalow, or that vulgar wish for smartness which characterises certain members of the mushroom nobility in our great towns, the architect's original design is so transformed that it can scarcely be recognised. It is a hard case for an architect to be credited with the authorship of a building to which he has been little more than the passive draughtsman, interpreting the wishes and taste of his client. If the practice which we believe now obtains in Belgium amongst architects of inscribing their names in small capitals at the right-hand corner of the main front of their buildings be generally adopted, it would be a decided hardship in this instance. The idea of inscribing the name of the author of a design is in itself a good one, so long as he is the real author of the work. On the other hand, it would be a grievance if he signed his name to a building that was really the outcome of a parsimonious client or an ignorant board. Anonymity would be far more desirable in such a case.

In the domain of plan also, the client asserts his opinion. Here we come on common ground. The employer who engages an architect to prepare plans for his business premises or his house has a right to ask for certain arrangements and accommodation, and, if so disposed, to suggest a plan. He is supposed to know best what he wants, though it is worth while to mention that, though he may have some idea of what he wants, he is quite unable to make a plan that can be built. We have known clients sketch out on paper roughly a plan of a house, as, for instance, the schoolboy's idea of a row of rooms with a long corridor entrance, or a square box with rooms on each side of a centre passage, but which are useless as guides to the architect. In short, he comes to an architect to put his wants into shape. Directly they are embodied in a plan, all kinds of alterations are suggested, such as a few feet more to this or that room, another bedroom or closet. The wife wants an alteration, or some friends suggest something that requires the whole recasting of the plan, and, as a consequence, the elevations. What other professional man has to put up with it? Does the painter, the sculptor, the lawyer, or the physician? No. His vocation would be gone if he made any such concessions or alteration in his plans. Even in competition, the patience and forbearance of the architect is sorely tried. In the recent Cardiff Municipal Buildings, selection the definite instructions of the committee have been set aside in the selected plans, as pointed out by a competitor last week. The plans premiated show, it is

alleged, many of the instructions ignored. Have we not also had similar complaints in the matter of the Battersea Baths? And have not our pages rung with the grievances of the Walthamstow and Finchley competitions? What is to be said of a committee who publish conditions which lay down certain requirements, and then ignore them altogether? Have we not here a proof of the inability of the lay mind to enter into questions of plan in a comprehensive manner, or of making up their minds on certain requirements? The fact of the matter is, an architect often sees a better way of obtaining the desired result by modifying the conditions; whereas the stickler to instructions may miss after all the most vital points in the scheme. The lesson is not to insist on hard-and-fast conditions in all cases. To mention another competition grievance: in some of these contests of skill, as in the pending Carshalton Hospital, the committee make the unsatisfactory stipulation that if necessary they retain the power to adopt the features of any of the designs they premiate, by which arrangement the brains of two or more competitors who are awarded prizes may be robbed at the mercy of the board—an exceedingly ungracious act, if not insulting to the competitors.

Sometimes, under the cloak of compliments, the architect receives a thrust not less wounding because it is given under the cover of politeness. We heard of a case lately in which an influential vestryman of an important board complimented an architect on a successful building, and promised him his support and recommendation after this fashion: "If you will send me your plans, I will have much pleasure in submitting them" (not to the committee for carrying out, but, alas!) "to our own surveyor!" What could be a greater slap in the face? But who has not been told quite provokingly: "I will show your plans to a friend, or to my committee, and if approved you shall hear further from me," or something of the same kind? Probably an architect would sooner submit his design to a layman or outsider than to a brother professional. It adds much to the annoyance to find one's plans or ideas have been appropriated by another professional man without acknowledgment or remuneration. Many competitors have cause for complaint on this score. The Walthamstow Baths grievance, which has been so recently discussed, does not stand alone. In many instances, a public competition seems to have been devised by a committee for no other purpose than that of providing the promoters with suggestions and plans at a small cost, usually the offer of a couple of premiums, both of which together would barely have paid the expenses of an architect of repute. And this view is confirmed by the treatment that has been meted out to successful competitors, whose plans have been in many cases carried out by the surveyor of the board. The Quebec Association of Architects have just issued a circular to their members, some of whom have taken part in competitions on very humiliating conditions, agreeing to make designs and obtain tenders without any chance of remuneration. Cannot we remember also instances of fictitious competitions, by which designs have been received, but the premiums have been withheld? Is it fair to assume that nobody has benefited? The pickings from the plans of say fifty designs amount to a robbery quite as audacious as if the promoters had boldly stolen the ideas of one man. On the former supposition the victimised could hardly complain; but, on the latter, the author could claim, if he did not always get, compensation.

The employment of so-called artists and tradesmen, who spoil the work of the architect, is the cause of much heart-burning to the sensitive soul. It is really hard on the

architect after his building is completed to find the decoration or fittings left to some decorative firm, as if he were not artist enough to complete his own design. This is one of the dangers due to specialism in art, and one which the architect himself should resent. If he can design a room in all its structural appointments, he is surely the right man to suggest its decoration. But, no; the decorative artist is consulted—a firm of decorators from Oxford-street or Tottenham Court-road. Unfortunately, the practice has grown from the mere negligence or apathy of the architect to assert his prerogatives, and those who are competent and ready to fulfil their proper functions have to suffer for the indifference of other members of the profession to claim their just rights. In the decoration of such buildings as town halls, theatres, and hotels the specialist designer or manufacturer is called in, or invited to prepare designs and estimates, so taking away from the architect perhaps one of the remunerative parts of his design. Between the tradesman, fitter, and decorator the architect's work is frittered away, while he is still held responsible for the shortcomings of those who supplant him.

#### INDUSTRIAL DEMOCRACY.\*

ONE of the most important developments of our age is trade-unionism, and its history and progress from the 18th century as it affects the various handicrafts has been made the subject of an interesting work in two volumes by Sidney and Beatrice Webb. The regulation of the conditions of employment has a special application to the building trades, whether we regard it as a result of economic science or in a more particular light. To take, for instance, the trade-union regulations as to apprenticeship, we find certain traditions that have come down from Mediaeval times. One of these was the reciprocal obligation between master and apprentice, the former agreeing to teach the mysteries of his craft, and the latter to serve for a given term for wages below the market rate. These obligations were enforced by the guilds. The conditions were: a premium paid, a certain age, a term of servitude, and a limitation of the number of apprentices permitted to the master. We know from the work turned out by members of these guilds how well this system worked. Besides this formal apprenticeship, the journeyman also had the privilege of bringing up his son in the trade, or, as it was known, "patrimony." This privilege does not appear to have been regulated by guild law, but on the custom of the workshop. It was, as the authors say, a "privileged exemption" from the law; the son could enter his father's workshop at any age the latter liked, and for any period. And we find this custom or "patrimony" became a vested interest, which is still strong in some trades. Mr. Webb gives instances of both these systems. The United Society of Boilermakers and Iron Shipbuilders have a formal code of rules regulating the admission of apprentices in all parts of the kingdom. There is a distinction between the "rivet boy," who is taught nothing, but is paid full wages, and the apprentice who is taught the trade. To become an apprentice to the trade, he foregoes half his earnings; but the raw youth can try his hand on work for which he is as yet unfitted—he does not do mere mechanical routine. To illustrate the latter system—apprenticeship to a journeyman—the authors refer to the cutlery handicrafts. Hereditary succession is universal, and no journeyman is allowed by the Britannia Metal Smiths to take an apprentice except he be his own or a journeyman's son, and he cannot have an

apprentice in addition. Under this rule any collective regulation of apprenticeship is out of the question, as the father adopts his own time and methods. The Stonemason's formal apprenticeship coexists with patrimony, and this is described. The rules of the craft vary in localities. There is a limit of one boy to five or six men. A youth after working three months at the trade is bound apprentice for five or seven years. An agreement is drawn up; every mason can bring up as many of his sons as he likes to the trade. The son is kept at work till he is 16 and strong enough to enter the trade, and then he works in the shop for the employer as an improver at a full man's wage. Other trades are described, but those we have noticed maintain apprenticeship regulations. In some trades of to-day the ranks of the unionists are recruited by men who have not conformed to such rules. The compositors form a handicraft of a highly-skilled body of men. Machinery has not been able to make the craft easier to learn, or to divide it. Mr. Webb remarks: "It is probable that a very considerable proportion of the men who obtain work as compositors, and join compositors' trade-unions, have undergone no period of educational servitude at all, with or without indentures, and have 'picked up' such knowledge of the trade as they possess whilst earning a full market rate of wages," and any attempt to limit the number of persons entering the trade has failed, no doubt owing to the wonderful progress of the printing industry, and the great variety of employers. So that, while in some trades which are in a flourishing condition the entrance is free and unguarded, in others, equally flourishing, like the boiler-makers and ship-builders, exclusive regulations are enforced.

The authors next consider "Progression within the Trade." The London builders cease to employ boys, the Operative Society of Bricklayers is recruited largely from young builders' labourers, who are allowed to decide up to the age of 25 whether they will abandon the hod for the trowel. The progression is unregulated by any rule. The Manchester Slaters' and Labourers' Society admits to membership as a labourer any man actually working with a slater, and from such the ranks are recruited. A labourer who desires to become a slater must serve seven years on the lower grade, and then apply to the secretary of the union. A committee of six practical slaters then examines the candidate in the mysteries of the craft, and if he passes he is recognised as a slater, and can demand full pay. The number promoted by the union is limited to three in each year. Many instances are given of the "over-lap" between trades. The lines of demarcation between allied crafts vary locally. In iron shipbuilding the most "numerous and complicated disputes" about over-lap are said to arise, and this obscuring of the lines between the trades has been brought about "by the gradual transformation of the passenger ship from the simple Deal lugger into an elaborate floating hotel." Thus the plumber has always done the sanitary work in vessels, but the iron piping of the steamship has been claimed by the engineer: hence plumbers and fitters both complain. Sharp conflicts have arisen on this account. Engineers have quarrelled with boiler-makers, shipwrights, the joiners, brassworkers, plumbers, &c.; the joiners have quarrelled with mill-sawyers, pattern-makers, and cabinet-makers. These disputes often create confusion and strikes and loss to the employer. Many interesting instances are given, and the authors point to a tribunal of the trade-unions to settle differences; the adjudicators are well versed in the technical details of the trades. The principle is pointed to on which the tribunal should act; it cannot be on any "right of the trade." The employer has the right to

decide which workman he will engage; therefore, "what each trade-union asks is that the recognised standard rate for the particular work shall be maintained." Here the authors rightly say: "The federated trade-unions, instead of vainly trying to settle to which trade a task rightfully belongs, should, in fact, confine themselves to determining, in consultation with the associated employers, at what rate it should be paid for." A definite standard rate for a particular task has been put forward by the general secretary of the Amalgamated Society of Engineers; and the authors' remark: If this simple principle were adopted, say, in the great shipbuilding yards, and accepted by the employers and the federation of engineering and shipbuilding trades, all would be well. The "standard" rate would be determined, as now, by collective bargaining between the associated employers and the trade-union, instead of by the individual employer or workman. In another chapter, on the "Verdict of the Economists," the arguments in favour of combinations of wage-earners are treated—that the workers should protect themselves by "higgling and bargaining" if they are not to suffer lower wages than there is economic necessity for. Professor Edgeworth and Professors Taussig and Marshall are quoted. The advantage of unions in benefiting the worker is generally admitted.

Considerable space is given to the custom of "higgling and bargaining" upon which the conditions of employment depend. The arguments for and against trade-unionism are temperately discussed in these chapters. In making labour contracts, the individual workman is at a disadvantage when compared with the capitalist employer. Many conditions cannot be determined by the workmen: the speed of work, its quality, how many hours he shall work, intervals for meals, fines, &c., are matters left to the foreman. The workman has to accept these conditions, for he cannot know beforehand what they are. "Moreover," the authors say, "unless fixed by law or collective bargaining, these conditions may at any moment be changed at the will of the employer or the caprice of the foreman. These, no doubt, are disadvantages to the isolated workman in bargaining with the employer. Trade-unionism remedies these defects of a "merely instinctive standard of life." This standard is described as the "existence among workmen of identical notions as to what constitutes their minimum subsistence"—itself a bulwark against the pressure of competition. But we must stop here. In the first volume the authors discuss Trade-Union Structure under four chapters: "Primitive Democracy," "Representative Institutions," "The Unit of Government," "Interunion Relations"; and in Part II, Trade-Union Function, such as "The Method of Collection," "Bargaining," "Arbitration," "The Standard Rate," "The Normal Day," &c. The authors of this valuable contribution to the important subject of trade-unions have given a lucid scientific analysis of trade-unionism, which has cost them six years' investigation and research. The various trade-union organisations and their regulations have been described in detail.

The second volume, dealing with the function of unionism, is the more important, perhaps, to the economist and politician: the psychological origin and reason of each code of rules is revealed, these being the intention which originated them, or the grievance to be met. On the whole, we must say the authors have ably handled the task they have undertaken, whatever judgment may be passed on the facts and generalisations which will always remain more or less speculative. But as an economic theory based on incontrovertible facts and assumptions, the authors have made a strong case for these protective agencies and the value of combination.

\* Industrial Democracy. By SIDNEY and BEATRICE WEBB. Two Volumes. London: Longman, Green, and Co.

WROUGHT-IRON AND STEEL IN CONSTRUCTIONAL WORK.—XXXIII.

**TIE-RODS** or tension-rods are used on roofs and bridges chiefly. Much depends upon them, and their dimensions, forms, and methods of fitting vary. Tie-rods are used in two forms—those of round, and those of rectangular oblong

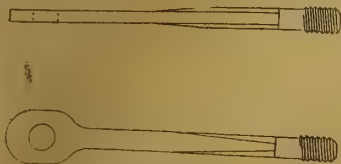

FIG. 219.

section. The first are generally preferred when there is nothing to interfere with the breadth of the rod, the latter when rods are confined sideways, as when two or more rods have to be laid side by side, or have to pass each other in a contracted width. But generally, most rods of small area of section are round, and those of large section rectangular.

Rods are secured in three ways—one by means

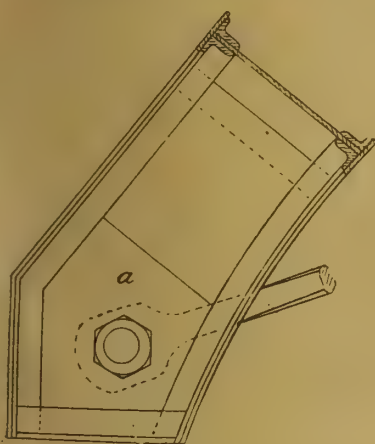

FIG. 220.

of pins, another by screw nuts, the third by wedges. The second can only be employed on rods, the ends of which are of a circular section; the other two are applicable to each form. The rods themselves are in tension; but their fastenings are in shear. In order to the tightening up of long lengths of rod, it is often necessary to resort to the use of capstan nuts, or of long sleeve



FIG. 221.

nuts. The workmanship of these connections is the subject of strict specifications, because the failure of a tie-rod will often mean collapse of the principal members. The area of cross-section of screwed ends, the area of the metal on each side and at the ends of eyes, the question of welding on of eyes are, therefore, subjects of the

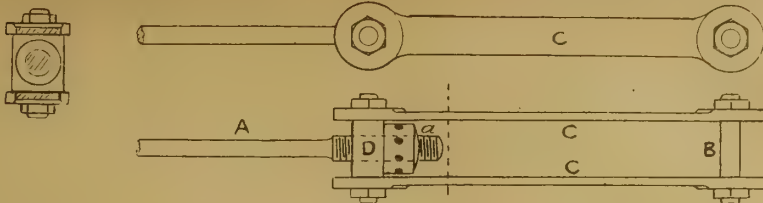

FIG. 222.

tainty in regard to welds made in steel, while there is hardly any risk when wrought iron is concerned. Neither, apart from special machinery, can steel be upset so satisfactorily as iron. It follows that eyes and enlarged screwed ends can be safely welded on iron rods, and that small extensions also can be upset on iron, the results of which are more uncertain in steel. Rods in steel can be made lighter than those of iron for equal strength, but that can only be done when the workmanship is fully reliable. In saying that steel is not so readily and reliably welded as iron, that does not mean that welds cannot be made, but that they are not to be trusted. In careful hands good welding can be done, but this is just one of those matters which must always be uncertain. A little scale in the middle of a weld, some unequal heating, insufficient hammering of the right sort, may cause a weld apparently sound as far as external appearance goes, to be of not half the strength of the solid bar. It is for this reason distrusted, and only tolerated when absolutely unavoidable. The Board of Trade imposes severe restrictions on this kind of work. In the hands of a specially-skilled workman, such welding is practically safe, but the steel should be of the mildest.

In the fitting of eyes and pins, rough or black fits are only permissible in some of the lesser details. In the main ties at least, all pins must be turned, and their holes drilled or bored. This is necessary in order to insure an equal distribution of stress. Without this, one cannot be sure that a pin is in double shear, or that a rod is not receiving an initial twist or pull, tending to draw it out of a straight line. It is not desirable that the fit be tight. On the contrary, there should be sufficient freedom between the pin and its holes to permit of its being thrust in by unskilled labourers without the need of oiling, as in the case of much high-class machine work;  $\frac{1}{16}$  in. of difference in size is a suitable allowance.

Eyes or links are generally made from the solid metal—that is, they are not bent round and welded, as is the practice in some light work, in which the hole bears a large proportion to the metal surrounding it. In the latter it is better to bend the eye when wrought iron is used, because the strength is greater across the fibre than parallel with it. In the former kind of work, however, it simplifies the workshop details to punch or drill through the solid, and leave an excess of metal at the end where the grain is short. In steel there is practically no grain, and no difference in strength either way; and as, further, welds in steel are uncertain, the practice is to form all steel eyes from the solid.

Eyes, and screwed ends generally, have to be made in such large quantities for a big contract that special means are adopted to expedite the production, and to insure absolute uniformity in all, so that if necessary all of a given dimension would be interchangeable. This is too wide a subject to treat in a series like the present. But briefly, these methods may be summarised as follows:—

why machinery is laid down for such a method is because nearly all American bridges are pin-connected. In England there is no such plant, and the method adopted here in the formation of long tie-rods is to forge the eyes and the screwed ends separately from the main body of the rod, and after having done the work of drilling the first and screwing the second, to weld them with long scarfed joints of, say, from 4in. to 10in. in length—dependent upon diameter—to the rods. This method saves all trouble in manufacture otherwise due to the handling of long tie-rods, and in the case of iron there is no special difficulty in welding. In the case of the very short rods there is no need to adopt this plan, but the rod may be drawn down by fullering between the ends from a bar of the full area of the ends.

In reference to the methods of formation of the eyes and screwed ends separately from their rods: These are roughed out nearly to shape in the

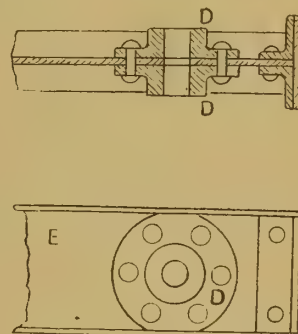

FIG. 223.

forge, and the precise finished shape is imparted in dies of cast iron or of steel under the steam-hammer. A hundred or a thousand will then all be precisely alike, and an enormous amount of time otherwise spent in finishing to neat outlines is saved. If deemed necessary, the holes in eyes can be punched at the same heat as the finishing to outline in the die, and this is generally desirable, because it does not injure the metal, and it saves some time in the subsequent boring. The screwed ends are cut in a screw-cutting lathe, and when quite finished, eyes and screwed ends are welded, and the rods are ready to go into place.

Taking now a few examples of tie-rods. Figs. 219—221 illustrate an eye-bar end of a tie-rod and a method of its attachment. The length, Fig. 219, is one which can be best forged by drawing down without any welding. In Figs. 220, 221 it is seen fastened to a roof principal, Fig. 220 being in elevation and Fig. 221 being a section through the principal, just above the rod. The web of the principal, though single throughout the greater portion of the span, is doubled

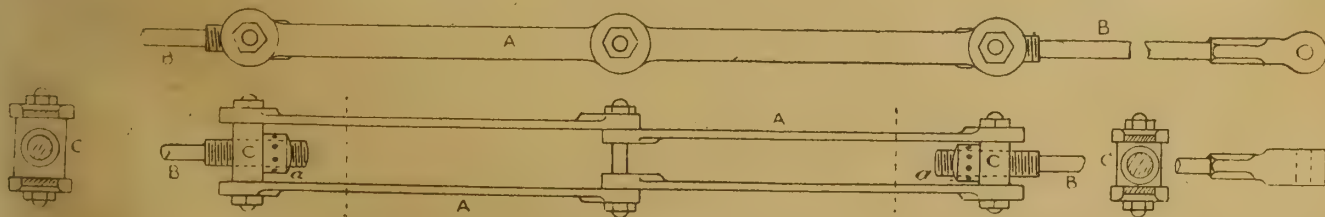

FIG. 224.

first importance. Fortunately, strains are always of a direct and simple character, instead of uncertain, as they often are in many riveted joints. Though steel is often used in tie-rods, wrought iron is also still largely employed. The reason lies in the fact that there is always some uncer-

American practice, as remarked in a previous article, differs from ours in respect to the formation of steel eyes. These are upset by special forging machines, by which the fibre is so coerced that the upsetting does not open it out as it would by hammer processes. The reason

and spread out laterally at and near the feet, where they rest upon the supports. The tie-rod ends are therefore fitted between the double webs and united with a pin. At the locality where the pin-connection is made, the webs are strengthened with additional outer plates *aa*. At A is seen the

long screw-nut, by which the rods are tightened up.

Figs. 222, 223 show another way in which to connect a tie-rod A to a pin-connection B in a rafter of joist section. Two links CC embrace the ends of the pin, and a forged block D receives the end of the tie-rod, which is tightened with a capstan nut *a*, by which the tension is adjusted. The pin-connection B passes through castings

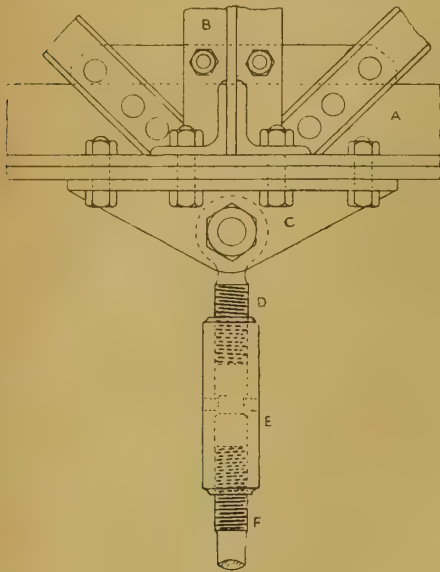

Fig. 225.

DD on the faces of the rafter E, Fig. 223, and riveted through it, and the links CC clear the flanges of the joist which forms the rafter.

Fig. 224 illustrates a pair of links A A connecting tension-rods B B. The links themselves are united with a bolt at the centre, and blocks or

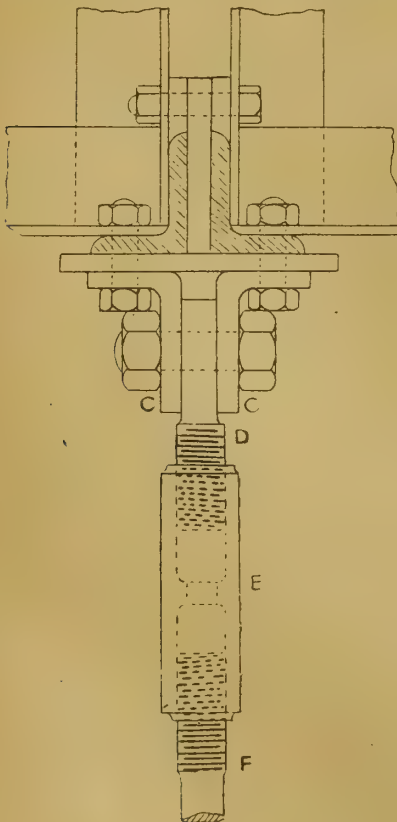

Fig. 226.

cross-heads CC are bolted between the links at the ends to receive the screwed ends of the tie-rods. The rods and links are strained to their proper tension by the circular capstan nuts *aa* pulled round with a tommy.

Figs. 225-228 show fastenings for radial-supporting rods connecting the principals and ties of the Liverpool Central Station. They are

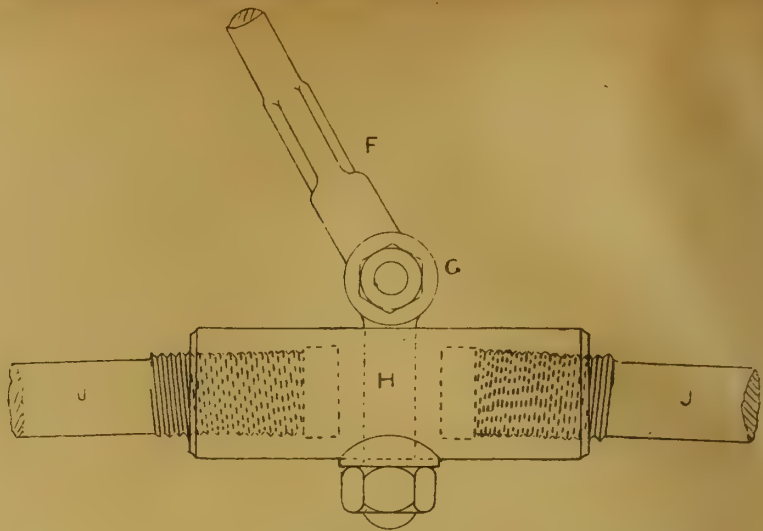

Fig. 227.

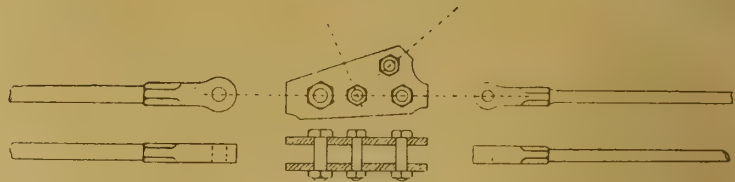

Fig. 229.

attached to the principals beneath the purlins, with provision for tightening. At the tie-rod ends also there is provision for tightening the lengths of which the tie-rods are composed. In the Figs., A is a portion of the principal, B a portion of a purlin, CC two wrought-iron brackets bolted to principal and purlin. The suspension-rod, with connecting tightening-nut, is made in three portions, the short length D, Figs. 225, 226, having a screw at one end, and

Fig. 229 shows a triangular-shaped pair of connecting links which serve as a point of union for three tie-rods, and one strut, at the different angles indicated. These plates are of wrought iron or steel. The ends of the horizontal tie-rods are shown to right and left.

The attachment of a tie-rod to the ends of a principal by means of wedges is shown in Fig. 230. Two broad jaws, A A, forged from plate, and tapering in depth or in width, are

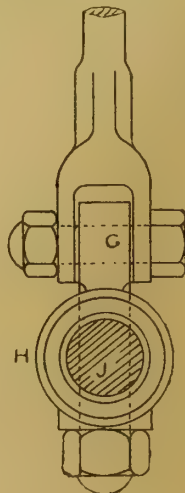

Fig. 228.

an eye at the other passing between C C, the main portion F extending down to the horizontal tie-rods; F and D are put into proper tensional adjustment by the long sleeve-nut E. Below D there is the short length G, Figs. 227, 228, with



Fig. 230.

eye-bolt and nut to pass through the tie-rod sleeve-nut H, which is screwed right and left-handed to suit screws in the ends of the tie-rod lengths J J. The ends, it will be noted, are enlarged at the screwed portions to preserve the strength of the rod unimpaired, and the sleeve-nuts are of sufficient length to permit of ample range of adjustment.

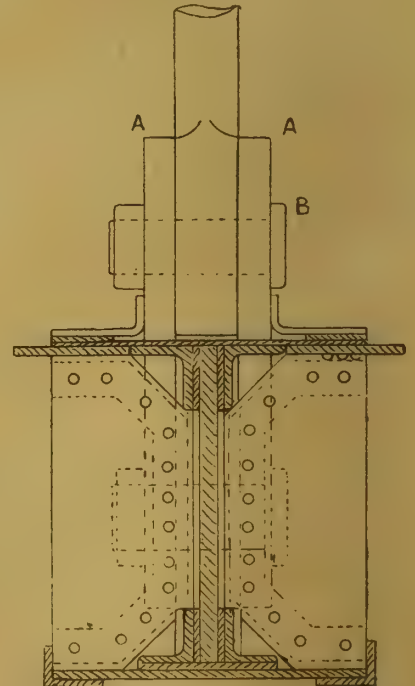

Fig. 231.

riveted to the webs of the principal, which is spread out at the base similar to Fig. 220. Cottar-ways are slotted in the tie-rod end B to receive the gib *a* and cottar *b*, by which the tie is tightened up.

Figs. 231, 232 illustrate in elevation and in vertical section the method of attaching the suspension links to the cross-girders of the roadway of the Tower Bridge. The girders are single-webbed, but are thickened up at the ends where the links are attached. Here broad plates

are riveted on each side of the web, and against these the massive links A A are fastened with bolts. These links measure 1ft. 2in. by 3in. in

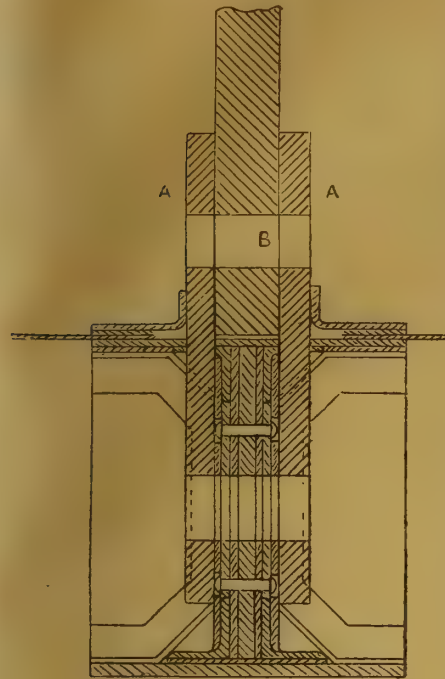

FIG. 232.

cross section to receive suspension pins, the pins B being 6in. diameter. The ends are further stiffened with angles and gussets, as shown. Fig. 233 illustrates another eye-and-pin connection on the same bridge. Whenever the

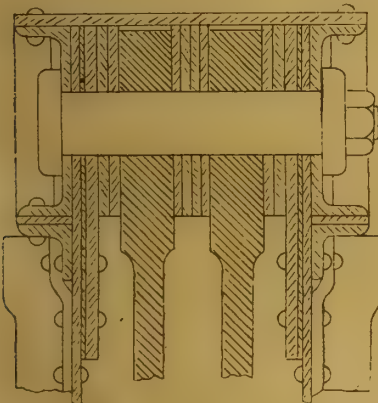

FIG. 233.

original strength of any portion of a structure is reduced by the removal of metal therefrom, it is necessary to reinforce that section in the manner shown in the figures. J. H.

THE SURVEYORS' INSTITUTION.

AT the meeting of the above society on Monday evening last the discussion was resumed on Mr. Punchard's paper (read at the ordinary general meeting of December 10th), on the suggestions for improving the relations between landlords and tenants put forward by the commissioners who have lately reported on the condition of agriculture in the United Kingdom. The discussion was resumed by Mr. Albert Buck, of Worcester, who held a decided opinion that freedom of contract between landlord and tenant was the only practical means of insuring good cultivation and the honest fulfilment of the terms of agreements on both sides. Tenants should be compensated, he held, for farming, which really improved the land, but not for any theoretical claim in cases where they left their holdings impoverished. Much verbiage might have been saved if it had been decided that a tenancy could not be terminated at less than two years' notice to quit, with a proviso that if it were terminated in a less time there

should be a claim for compensation. There was, he feared, a tendency to so expand the provisions of the Act as to give the tenant compensation for what he had agreed to do by his lease, and, indeed, was, in common law, obliged to do. He did not think that any great alteration in the procedure for ascertaining the amount claimable and payable was necessary. Arbitration was the only way in which such matters could be decided. If the tenant and the landlord did not agree on the amount to be claimed and paid by one side or the other, someone must decide between them, whether it be a person mutually agreed upon or one appointed by the Board of Agriculture or any other public body. Whether the landlord and the tenant should send in their claims and counter-claims at the same time was a difficult question to decide. He thought, on the whole, that no further legislation could, for the present at any rate, do much good. A land agent should do the best he honestly could for both landlord and tenant, and it was in this way that he would best study his employer's interests.

Mr. E. P. Squarey said that these were generally matters easily settled by a wise landlord, a wise agent, and a sensible and right-minded tenant; and given these conditions, he did not think the Act would be very widely acted upon. But, unfortunately, the three were not always co-existent, and a necessity would, from time to time, arise for dealing at the end of a tenancy with questions of tenant right and compensation. The commission with whose report the paper dealt had a very difficult task. He was not quite sure that Mr. Punchard did not lean a little too much to the landlords' side. It was all very well to seek the aid of the legislature in these matters; but what he thought was wanted was a determination on the part of both landlords and tenants to do what was right and just the one to the other, and not to rely on any details of legislation which might give either of them a technical advantage. As to laying down land for permanent pasture, he thought that the tenant ought, one year before the end of his term, to give the landlord notice whether he intended to claim compensation. With regard to claims for the manurial value of feeding stuffs consumed, he thought that sufficient allowance was not made by valuers for the very different conditions under which they were consumed—whether in closed and properly-drained sheds, or in open yards, or even in open fields, or whether during continuous wet or dry weather, when their value would be very different.

Mr. J. A. Eggar thought that in some ways the present Act might be amended. There should only be two classes of improvements—those which were permanent and those which were exhaustive. The former might well be borne by the landlord. He thought the laying down of permanent pasture, the necessary fencing, and the plant of hops might well be transferred from the first to the second part of the schedule of improvements. If pasture remained good permanent pasture for any number of years, it was probably due to the inherent capabilities of the soil, and not to the tenant's action.

Mr. J. H. Savin and Mr. G. J. M. Burnett having spoken, both agreeing in the main with Mr. Punchard's conclusions, the meeting then adjourned.

It was announced that at the next meeting, on the 24th inst., a paper would be read by Mr. A. A. Hudson, barrister-at-law, on "Surveyors as Arbitrators."

BUILDERS' AND SANITARY FITTINGS.

A VERY compendious and well-illustrated catalogue has been issued by Messrs. George Wright and Co., of 155, Queen Victoria-street, E.C.4, and Rotherham, comprising nearly every variety of builders' ironmongery, marble and slate mantelpieces, stable and cowhouse fittings, pavement lights, &c. It is impossible to give any adequate idea of the variety of goods and designs illustrated. The marble, wood, and cast-iron mantelpieces contain many good designs in all the chief kinds of marbles and woods, and suitable for every kind of residence. Several very simple designs are shown made in pine, painted, with overmantel, tile panels and hearths, and Berlin black interior. A large assortment of mantel registers of all sizes and prices, some with movable canopies, are illustrated. The grates with removable swing canopy, which acts as a register door, are economical, neat in appearance, and very moderate in price—from £2 and

upwards. The kitchen ranges from 2ft. to 12ft. are shown in a variety of shapes, and deserve the attention of all builders and architects who require substantial workmanship. The directions for fixing kitcheners are useful. Several large and very perfect c'ose-fire kitcheners, with grilling stove and hot closets—suitable for large establishments and hotels—steam cooking apparatus, and grilling stoves are shown. The sections on stable fittings and cowhouse fittings contain all the more recent and sanitary mangers and racks and arrangements of stalls. The descriptions and prices of each article are full and complete.

CHIPS.

The building works in New-street, St. Clement's, Ipswich, belonging to Councillor Fred Bennett, have just been extended over the site of an adjoining old malting with garden attached. The additional premises contain fresh machinery, including framed stone-saw, mortar mill, and a crane with 4ft. jib, and plumbing and painting workshops. The New-street works now cover an area of over an acre, and are situate close to the dock and river Orwell, in the oldest part of Ipswich.

A portion of a roadway, believed to be of Roman origin, has been found at Reigate. Some workmen whilst engaged in excavating for a sewer in Nutley-lane discovered a completely-formed roadway about 5ft. below the surface of the highway. The path is about 14ft. wide, and is composed of flints, the edges of which have been trimmed to fit, and is even in character.

Herr Dörfeld, the Director of the German College of Archaeology, who has for some time past been engaged in excavations between Pynx and the Areopagus, believes that he has discovered the ancient system of drainage, with all its ramifications. The pipes, which are in a good state of preservation, conducted to the various quarters of the city the water flowing from Mounts Pentelicus and Hymettus, and the small streams from the Acropolis.

Colonel W. R. Slack, R.E., an inspector of the Local Government Board, held an inquiry at the Town Hall, Leyton, on the 6th inst., into an application by the urban district council for sanction to borrow £2,125 for public street improvements, £7,618 for private street improvements £1,530 for purposes of electric lighting and £1,300 for the purchase of a site for public baths and washhouses.

At the last meeting of the streets and sewerage committee of the Leeds Corporation, Alderman Harding reported that the experiments in the bacterial treatment of sewage which were being carried out at Knostrop, under the supervision of Mr. W. J. Dibden, of London, had had very encouraging results. Daily analyses of the effluent were being made at Mr. Dibden's laboratory and by Mr. Fairley, the city analyst. The experiments are being watched by the West Riding Rivers Board, and analyses on behalf of that body are also being made.

The town council of Longton, Staffs, having applied for sanction to borrow £20,000 for gasworks purposes and £4,075 for purposes of street improvement, Mr. H. P. Boulnois, M.Inst.C.E., an inspector of the Local Government Board, held an inquiry at the town-hall on Friday into the applications. Mr. W. S. Macgregor, the gas manager, explained the plans for improvement at the gasworks, and Mr. J. W. Wardle, the borough surveyor, those for street improvements.

Figures carved in Beer stone, and representing the Evangelists, have been erected over the communion table at St. John's Church, Yeovil. They have been executed by Messrs. Harry Hems and Sons, of Exeter, from designs by Mr. J. Nicholson Johnson, A.R.I.B.A., of Yeovil.

New outfitting premises are in course of erection at Camborne, for Messrs. Vivian Brothers. Mr. Silvanus Trevail, of Truro, is the architect; and Mr. John Colliver, of the same city, the builder.

On Saturday a girls' home at Newport, Salop, was opened by the Bishop of Shrewsbury. The building is intended for the reception and training of friendless girls from workhouses and elsewhere. Messrs. Veall, of Wolverhampton, were the architects, and Mr. Whittingham, of Newport, was the builder.

On Thursday in last week, Mr. R. H. Bicknell held an inquiry at Wednesbury on behalf of the Local Government Board, with reference to applications for sanction to loans amounting to £3,101 for the purpose of a fire-brigade station and other public improvements.

The Goldsmiths' Company, who are the ground landlords of a large portion of the devastated area, have signified their readiness to cordially acquiesce in any scheme the Corporation and the London County Council may arrive at for the improvement of Cripplegate.

## OBITUARY.

MR. H. STACEY MARKS, R.A., the well-known painter of birds in numerous attitudes in oil and water-colours, died on Sunday at his residence in Regent's Park, aged 68, after a very short illness. In his earlier years he was a successful decorative painter: he designed proscenium friezes for the Gaiety Theatre and other playhouses, did part of the frieze running round the outside of the Albert Hall, and carried out a good deal of work at Eaton Hall, Crewe Hall, and other private houses. Mr. Marks became an Associate of the Academy—in whose schools he had been trained—in 1871, becoming an R.A. seven years later, and retired a few years ago.

## CHIPS.

The Walthamstow Urban District Council having applied to the Local Government Board for sanction to borrow £11,000 for the erection of an infectious hospital at Larkwood Lodge, Chingford Hatch, Dr. H. Timbrell Bulstrode held an inquiry at the Town Hall, Walthamstow, on Tuesday in last week. Mr. G. W. Holmes, surveyor to the council, showed the plans which he had prepared.

The new schools, Farnworth, near Widnes, are being warmed and ventilated by means of Shorland's patent Manchester grates, the same being supplied by Messrs. E. H. Shorland and Brother, of Manchester.

New church schools on Galley Common, Stockingford, built at a cost of £1,400, were formally opened by the Bishop of Coventry on Thursday in last week.

On Thursday, the 6th inst., Mr. H. Percy Boulnois, M.I.C.E., of the Local Government Board, held an inquiry at the Shire Hall, Stafford, respecting an application by the town council for sanction to borrow £20,000 for the purposes of the Stafford Corporation Act, 1806, and £4,000 for water-supply purposes.

On Tuesday, four men who were at work on the new Roman Catholic Cathedral, which is being built in Ashley-place, were thrown to the ground owing to the collapse of the planking of the scaffold they were on. They were so seriously injured that they had to be taken to Westminster Hospital. Their names are—Peter Pennythorne, 28; David Seymour, 28; Frederick Frost, 25; and Arthur Brooks, 30.

The Dean and Chapter of Peterborough Cathedral have requested Mr. G. A. Bodley, A.R.A., to examine and report upon the condition of the west front of the cathedral, and also of the transepts and eastern chapel of the choir, with a view to carrying on the work of restoration. This course is necessary, owing to the death of Mr. J. L. Pearson, R.A., under whose advice the previous restorations have been carried out. Scaffolding is being erected with a view to restoring the south-west gable of the front.

By his will, which bears date September 6, 1895, with codicils of May 26, 1897, and August 28, 1897, Sir Henry Doulton, of the firm of Doulton and Co., potters, left personal estate valued at £309,483 8s. 4d. He bequeaths to the Pottery and Glass Trades' Benevolent Society £100, and to the Lambeth Pension Society £200.

The first annual dinner of the Hereford and District Master Builders' Association, which was established on March 20 last and has now a membership of 13, took place at the Mitre Hotel, Hereford, on Tuesday evening in last week. The chair was occupied by Mr. William J. Bowers, president of the association, who was supported by Mr. Alderman H. C. Beddoe, the Mayor of Hereford, and Mr. A. Krauss, of Bristol, president of the West of England and South Wales Federation of Master Builders. The toast of the evening was proposed by Mr. W. Symonds and acknowledged by the president, and that of "The Architects and Surveyors" was proposed by Councillor James Davies and acknowledged by Mr. E. H. Lingen Barker, the senior architect practising in Hereford.

The Croydon Town Council received on Monday a report from the fire brigade sub-committee as to the result of their investigation into circumstances of the recent fire at the premises of Mr. Horrocks, builder, Croydon, by which damage to the extent of £4,000 was done. They stated that, although they found no fault with the conduct of the brigade at that particular fire, it was proved that there had been great laxity of discipline, and that the men, in defiance of strict printed instructions, frequented licensed houses in the neighbourhood with the knowledge and consent of Superintendent Thomson. They, therefore, recommended that Engineer Bowers and Fireman Filce be discharged, and the superintendent severely censured. Several members advocated the dismissal of the superintendent also, but eventually the committee's report was adopted unanimously.

## Building Intelligence.

BRAEMAR.—A commencement has been made with rebuilding the Fife Arms Hotel, Braemar. The plans and specifications have been prepared by Mr. A. Marshall Mackenzie, A.R.S.A., Aberdeen, and a start has already been made with the work. The undertaking will take three years to complete, and in order that the tourist season may not be interfered with, the work is to be done in sections. The first part of the building will be completed in time for the season of 1898.

EDINBURGH.—At the annual meeting of the Royal Infirmary, held last week, a report was presented as to the extension scheme. After consideration, plans for the new pavilion have been passed, and estimates for the necessary works obtained. The amounts of the accepted tenders were as follows:—(1) Excavator, mason, and brickwork, £13,648; carpenter and joiner work, £4,980—£18,628; (2) slater work, £377 15s. 3d.; (3) plumber work, £3,188; (4) plaster work, £1,273; (5) concrete work, £2,366 7s. 6d.; (6) tiler work, £3,355 0s. 11d.; (7) smith work, £1,610 3s.; (8) glazier work, £364—total, £31,162 6s. 8d. The pavilion will be five stories high, and will contain basement, three floors of wards, and attics. On the basement floor the new bathing establishment is placed.—In a review of the past twelve-month the *Scotsman* says:—The building trade has been very busy during the year. Save for the delay caused for a few weeks by the strike of the masons for an eight-hours' day, work has gone on without interruption. The result of the strike was a concession of the men's demand. The eight-hours' day should begin on the 15th February, 1898, but as yet nothing has been done regarding the inauguration of the new system. When the demand was granted, the men were earning 10½d. and 10d. an hour; since then, in most places, the pay has been reduced to the standard rate, 9½d. Besides, the masters have lately purchased machinery to do stone sawing and dressing, equal to a displacement of 200 men. The activity of builders during the year has not been due so much to contract work as to the fact that money has been cheap, that people are removing their money from foreign securities, and that the desire of those people to invest their funds in houses has led to the erection of a great deal of speculative property. Now, however, notwithstanding the extension of the city in nearly all directions, the market is more than supplied, and it is expected that next year speculative builders will take a rest. Besides the large number of tenements, villas, and continuous self-contained houses erected, a considerable amount of public work has been done in connection with the Waverley Station and North Bridge, and new North British Railway Offices, the reconstruction of the Royal British Hotel, the foundations of the North British Railway Company's Hotel, additions to the electric light station, large works at Carson-street, the building of new premises for several assurance offices in St. Andrew-square, the erection of cable-power stations at Tollcross and Shrubhill, additions to the Advocates' Library, a new laundry at the Royal Infirmary, police stations at the Pleasance and at Croft-an-Righ, the public shelter and golf-green keeper's houses on the Braid Hills, and preliminary work for the extension of the Municipal Buildings. The number of warrants, &c., granted in the Dean of Guild Court was 916, which is a great increase over any year during the last five years. They represented 99 villas, 120 self-contained houses, 194 tenements with 138 shops and 2,183 dwelling-houses, 182 public and other buildings, and 319 alterations. As to the prospects for next year, there are the City Hospital at Colinton Mains, not yet above the level of the ground, the new City Chambers, the extra pavilion at the Royal Infirmary, the North British Railway Company's hotel, and, probably, a new central station for the fire brigade.

GATESHEAD-ON-TYNE.—The new offices of the School Board were opened on the 8th inst. These buildings have been erected from designs prepared by Mr. Edwin Bowman, architect, of Newcastle, which was selected in open competition in May, 1896, out of 11 designs submitted, the cost being limited to £3,500. The buildings are of red brick, with moulded and carved stone dressings. The entrance is by a stone portico, with stone columns and entablature. On the ground floor is placed the general office, 44ft. by 19ft., adjoining which are the private office of the

clerk of the board, book-keeper's room, telephone room, strong room, and waiting-room. The attendance officers' rooms are placed at the north end of the building, and have separate entrances to them, as well as communication with the other offices. On the first floor, is placed the board-room, 35ft. by 26ft. This room is 15ft. high, with panelled plaster ceiling, and panelled wood dado. Adjoining the board-room is the members' private room, with cloak and retiring rooms thereto. The waiting-room, committee-room, and other apartments adjoin. The rooms are warmed by hot-water pipes and radiators, which is supplemented by open fires in each room. In the basement are store-rooms and the heating chamber. The contract for the building was £3,482, which has been carried out by Messrs. T. and R. Lamb, of Gateshead, under the personal supervision of the architect, with Mr. Wm. Edington as clerk of the works.

GLASGOW.—St. Patrick's Roman Catholic Church was opened last week. The new church is situated at the corner of North-street and William-street, Anderston, and is designed in the Early Decorated style. The nave is divided into seven bays, and is 102ft. long by 30ft. wide. Including aisles, the total width is 59ft. The clerestory is supported by three arches, each of a span of 27ft. These arches are carried by granite columns, so that two columns practically support the weight of the clerestory on either side. In each of the seven bays of the clerestory is a five-light window with traceried head, and in the bays of the aisles, on the Epistle side, are two two-light windows with traceried heads. The west window is divided into seven lights, with traceried head, and is 32ft. high. The baptistry is placed at the end of the aisle on the Gospel side, and is lit by a three-light traceried window, and the confessionals are in recesses in the aisle on the Gospel side. The chancel, which is 32ft. in length, is divided from the nave by a chancel arch, and terminates with a five-sided apse, in each bay of which is a two-light window with traceried head. The side chapels are divided from the chancel by an arch, over which are two two-light windows with traceried heads. Each chapel is lit by a rose window. There are two doors under the great west window, approached by a flight of steps from North-street. The organ-gallery at the west end is reached by a circular stone staircase. The roof, supported by six principals, has a total height from floor to ridge of 67ft., but is ceiled internally at a height of 57ft. Accommodation is provided for over 1,000 worshippers. The presbytery is connected to the church by a corridor from the sacristy. The church and presbytery, which are both lit by electricity, are built of Locharbroggs stone, the roofs covered with slates from the Aberfoyle quarries. The church has cost £9,000. The whole has been designed and carried out under the direction of Messrs. Pugin and Pugin, of London. Mr. Harvie was the inspector of works.

GORBALS, GLASGOW.—The memorial-stone of Gorbals Free Church was laid on the 6th inst. by Lord Overton. The church is situated in South Portland-street, occupying a position between two high four-story tenements, thus presenting unusual difficulties in plan and design. These have been dealt with by filling up the whole frontage block with the entrances, hall, and rooms, while the church is placed behind these, being lighted from each side. The church itself is square in plan, with side and end galleries, and will be seated for 918 persons. It is internally divided into a nave and side aisles by iron columns which support the galleries and roof, and steel girders over the galleries divide the roof longitudinally into three sections. The central portion is carried up much higher than the sides, and is finished with a coved and panelled ceiling divided into six bays by moulded timber couples. At the pulpit end two stone piers divide the space into three, the side sections forming organ-chambers, while the centre is occupied by the platform. The pulpit will be an open platform, with only a small reading-desk in front. The church will be lighted by two tiers of triplet windows. The hall is placed on the first floor on the gallery level, and is a room 60ft. by 27ft. 6in. A beadle's house occupies a portion of the upper floor. There are also on the basement two lesser halls, each for 160 persons, a kitchen, store-room, and lavatory; and on the street floor are ladies' room, vestry, deacons' room, and cloak-room, with lavatories, and an extra vestry. The style is Classic, of a severe



type. Each flank of the front is kept forward to the street line, and carried up unbroken to the cornice, so as to contrast with the adjoining tenements, while the centre is recessed a few feet. The stonework is of red sandstone from Gatelow-bridge quarries. The estimated total cost is £6,500. The architect is Mr. John B. Wilson, A.R.I.B.A. and I.A., Bath-street, Glasgow, and the work is being carried out under his supervision, with Mr. James Mair as clerk of works.

MANCHESTER.—The Art Gallery Committee presented a report to the city council at its last meeting as to the necessary arrangements and cost incident to continuing the autumn exhibitions. The committee say that they have considered the additional space necessary to enable them to carry on the work of the steadily growing permanent collection, the autumn exhibition, and the other exhibitions which they have been accustomed to hold; and they have come to the conclusion that to adequately meet this requirement they will need increased accommodation equal to that afforded by the existing galleries, which will very soon be only large enough for the permanent collection. "Three possible ways," the report goes on to say, "of obtaining the additional accommodation have been considered by the committee: (1) the erection of a temporary building on land now belonging to the corporation; (2) the sale of the present building and its site, and the erection of a new and larger building on another site; (3) the erection of additional galleries on land behind the present building. Proposal 1 has been rejected as undesirable; proposal 2 has much in its favour, especially if the new gallery could be built on the same site as and in connection with the new reference library; but, on the other hand, there would be very great and general reluctance to consent to the abandonment and pulling down of the present building, which is not only one of the best examples of architecture in Manchester, but also contains a fine suite of galleries admirably adapted for their purpose. Proposal 3 is the one recommended by the committee. If the plot of land between the present building and George-street could be acquired at a reasonable price, it would afford space for a building providing galleries at least equal in extent to the present ones. Communication could be established between the two buildings, so as to form one magnificent suite of galleries sufficient for all needs for very many years to come. The initial cost of the new galleries could be considerably reduced by erecting only a one-story building; or the annual cost could be reduced by reserving the ground floor of a two-story building for offices to be let for business purposes. But it would be much more satisfactory to have a two-story building entirely devoted to the work of the committee, who could make good use of both floors.

MELLOR, LANCS.—St. Mary's Church, Mellor, was reopened on Thursday in last week, after having been renovated at a cost of £3,500. The roof and coping stones have been repaired, the Dodgson monument has been placed inside the church, and a substitute erected over the family vault; and the Hargreaves, Dodgson, and Troy windows have been protected with sheet glass. An organ has been built by Mr. Edwin Smith, of Blackburn. The organ-case is of quartered oak, with spotted metal speaking-pipe front. The keys are of ivory, with overhanging upper manuals, and the key-fittings, desks, &c., are of polished walnut. A new font, with oak cover, has been given, and is a copy of a 14th century font, which was discovered buried beneath one of the porches of the old church at Welshpool. Mr. Varley, of Blackburn, carved the front, and Mr. Harry Hems, of Exeter, the cover. Messrs. Paley and Austin, of Lancaster, were the architects for the restoration, and Messrs. J. Hatch and Sons, of Lancaster, the contractors.

NEWCASTLE - ON - TYNE.—The memorial-stone was recently laid of Erskine Presbyterian Church, Rye Hill. The church, which is to be erected on the old site, from designs and under the superintendence of Messrs. Badenoch and Bruce, architects, of Newcastle, will accommodate 500 persons, an increase of nearly 200 over the old building. It is Late Gothic in style. The walls will be of rubble, having on the main front sneaked rock facing and chiselled stone dressings. Staircases lead to galleries, which run round three sides of the church. The roof is of hammer-stone trusses in pitch-pine, with cleaded ceilings following the line of rafters and collars

and divided into panels with mouldings planted on. The existing schoolroom in the basement is not to be interfered with, but the front portion under the vestibules will be converted into a ladies' room and tea-room with wide vestibule and entrance lobby, lavatories, &c. The whole scheme includes a hall seated for about 150 on a vacant site to the north of the church, with minister's vestry, and on the basement level there will be infants' classroom, session-room, heating-chamber, and lavatories. The present contract is for the church only, Mr. Robert Veitch, of Barrack-road, being the contractor. The heating will be by low-pressure hot-water pipes and radiators, and the electric light is to be introduced.—The new Primitive Methodist church in Kingsley-terrace, Newcastle, replacing a smaller chapel in West-street, has also been opened. The church has been erected from the designs of Messrs. Marshall and Dick, architects, of Newcastle. The style is Early Gothic. The church consists of nave and transepts, and containing the bulk of the sittings on the ground floor. A small gallery, accommodating about 90, occupies the north end over the entrance vestibule. The total accommodation is for 500. The windows of the edifice are long trefoil-headed lights, and the roof is barrel-vaulted. The rostrum is recessed, and has doors on either side communicating with the vestries and stairs to hall below. In the rear and on the level are arranged the church parlour, the minister's vestry, and the steward's room. The hall in basement occupies about three-quarters of the area of the church above. Folding screens are arranged so that the space can be divided into classrooms. The heating is by low pressure hot water, ventilating radiators being placed in window recesses and elsewhere. An electric fan in the tower will be used to extract the vitiated air, and the buildings throughout are to be lighted by electric light. Mr. T. Hutchinson, Elswick-road, Newcastle, was the contractor.

RUM, N.B.—Mr. George Bullough, proprietor of the Island of Rum, is carrying on important improvements on the island. A mansion-house, the building of which was commenced last summer, is being erected, at a cost of nearly £43,000, on a site facing the entrance to Kinloch Bay, eastward. The main tower is to be 60ft. in height, and the other four towers, which occupy the corners of the rectangular building, 40ft. The basement floor, which contains the wine cellars, larder, and heating-apparatus chambers, is 152ft. by 130ft. On the ground floor is the drawing-room, dining-room, library, and morning-room, boudoir, business-room, smoking-room, hat and cloak rooms, luggage-rooms, servants' hall, and kitchen offices. At the south end there is a conservatory, 23ft. by 36ft. The quadrangle in the centre of the building is 45ft. by 41ft., and to the right of it is the ball-room, 23ft. by 31ft. The entrance-hall is 40ft. by 26ft. On the first floor, besides the upper part of the ball-room, are eighteen bedrooms, dressing-rooms, and bathrooms. The stone employed is red sandstone from the Corrie quarries in Arran. The woodwork generally is to be of oak, and for decorative purposes walnut and mahogany are to be used. The staircases are to be finished in oak, and the bath-rooms and lavatories laid with encaustic tiles. The windows have gun-metal casements, and all the flooring is fireproof, on the Fawcett system. The architects are Messrs. Leeming and Leeming, London. The improvements on the island are not limited to the erection of the mansion. New gardens, greenhouses, and vineries are being formed at the cost of over £5,000. Arable ground near the old residence is being utilised for planting trees, and a large area of hill ground is being drained for farming purposes. Two other contracts have been let—one for the construction of half a mile of avenue leading from the pier to the mansion house, and erecting a bridge over the river at a cost of about £2,000; another of £3,000 for making a communication by means of a canal between a fresh-water loch and the sea, for the purpose of rearing trout and salmon. Another part of the improvements going on simultaneously is the construction of a highway from one end of the island to the other. The estate carpenters are also busy erecting accommodation for 25 horses.

The restoration of Dawlish Parish Church tower is completed, this concluding the whole of the external restoration to the church.

## Engineering Notes.

CREWE.—One of the most extensive operations undertaken of late years by the London and North-Western Railway Company is now in progress at Crewe. It will involve the outlay of upwards of half a million of money, and when it is completed the whole system will feel the benefit. Half a century ago Crewe was nothing else than a small hamlet, with a population, in 1831, of 148. To-day it is a borough, with a mayor and corporation, and 35,000 inhabitants. At present goods and passenger trains run freely over the same lines, and the company now proposes to do what it has already accomplished at Edgehill—separate the two classes of traffic; and, next, improve vastly the existing passenger accommodation. Crewe, before the extension, covered 93 acres; on completion of the alterations it will embrace 223 acres; its platforms will be upwards of 4,000 lineal yards in extent, just double the present length; the area of the roofed-in portion will be 40,000 square yards, instead of 12,160 square yards; and its sidings will be augmented in number from 140 to 220, with a total length of 30 miles, in place of 15½ miles.

MARYLEBONE.—Extremely rapid progress is being made, says *Engineering*, with the London terminal hotel, as with all the works in connection with the Great Central Railway. The hotel facing Marylebone-road is already up to the second-floor windows on all sides, and will be nearly rectangular in plan, the size being about 210ft. in width by 270ft. or so in length from north to south. Red pressed bricks form the material, with terracotta dressings. On the west side are six large windows on the ground floor, with terracotta arches, giving light to a banquetting-room. The Marylebone-road front is to have a central carriage-entrance into a covered courtyard, and there will be a subway from the hotel into the station. There will be seven stories, including two in the roof, with a clock-tower over the entrance. Col. R. W. Edis, F.S.A., is architect both of the hotel and the station. Of the latter not much is yet visible above ground, but the foundations are in for a good deal of it, and the ground is fast being excavated. Many lines of rail are laid all over the site, and most of the *débris* of the old houses is gone. The raised road in substitution for Boston-street over the railway at the north end of the new terminus is now finished. The road, which will be 45ft., will go straight on into Lisson-grove, emerging thence by the widening of St. John's-place. Between it and Alpha-road the principal goods-shed or warehouse is situated, thirty-five of its great iron columns being now in position. The girders binding these together at the first-floor level are partly up. Eleven-and-a-half acres of floor space will be provided in the goods station and warehouses. The goods-yard will lie entirely to the west of the passenger lines, and south of the branch which goes under Grove-road to the coal-sidings. The additional room would comprise 400 or 500 houses, mostly of a poor class, the rateable value being only about £9,000. Further out, the tunnel and covered way extending a mile from Wellington-place to the London and North-Western Railway is still under construction, and the further portion, on to Finchley-road, is finished. West Hampstead Station is being rebuilt on the new pair of roads north of the old ones, the latter being handed over to the Great Central, whilst the former will in future be the Metropolitan. West-end-lane bridge, which goes over both lines at this point, is being widened. A little further on the Great Central will be carried upon an iron viaduct, laid upon brick piers, leading on to the bridge over the North London Railway. The viaduct is now being constructed, as are the bridges adjoining Kilburn-Bronesbury Station.

THE JUNGRAU RAILWAY.—The latest report on the progress of this railway shows that the work of construction is being pushed forward, notwithstanding the severe weather prevailing in Switzerland. Water-power to the extent of 2,400 H.P. is now available at Lauterbrunnen, half of this force being utilised for the dynamos employed in the boring of the Eiger glacier tunnel. The mountain stream has been diverted from its course for a distance of six miles, extending from the waterwheel-house to Scheidegg station and the Eiger glacier, while the open line between the Scheidegg and the glacier, with its

tunnel of 88 yards, is finished, so that the electric railway over this portion will probably be opened in the first half of next June, and in time for the tourist season. The principal tunnel has been carried to a distance of 164 yards by hand-boring, and the preliminaries for tracing out the great tunnel have been accomplished after some two years of labour. The rock is found to be excellently adapted for tunnelling, and experiments on the Jungfraujoch has proved that it is reached at a depth varying from 80ft. to 100ft. under the snow, instead of at 230ft., as was at first expected. In connection with Swiss mountain railways, it may be mentioned that the opening trial of the Gorner-Grat Electric Railway from Zermatt has proved satisfactory. The line was completed a short time ago, and it is to be opened for passenger traffic early in the spring.

### COMPETITIONS.

**BOOTLE.**—Twenty-two competitive plans for the proposed new fire-station at Bootle have been sent in, and these are now exhibited in the town-hall of that borough. The author of the selected plans will receive as his award the appointment of architect of the buildings, with commission upon the contract; and a second prize of twenty-five guineas is also offered. The scheme, excluding the cost of the site, which is situated in Irlam-road, is not to exceed £15,000, and in the event of the Local Government Board refusing to sanction the borrowing of the money, the successful competitor will receive fifty guineas as remuneration for his work. The present site and buildings of the fire-station, which has proved inadequate for the requirements, together with the old and disused police-court adjoining it, have been purchased by the London and North-Western Railway Company, who intend to establish a goods station there. In the plans of the proposed fire-station, house accommodation has been made for twenty married and ten single men, so that, if necessary, the permanent staff, which now numbers twenty-four, may be increased. Mr. F. T. Turton, deputy land steward and surveyor to the Liverpool Corporation, has been recommended by the Bootle Fire Brigade Committee for appointment as the assessor to adjudicate on the designs. Mr. Turton prepared the plans for the new Central Fire Station in Liverpool, and for that purpose inspected the principal stations in the country.

**CARSHALTON: SOUTHERN CONVALESCENT HOSPITAL.**—For this important competition for a convalescent hospital, to be built on an estate at Carshalton, for the Metropolitan Asylums Board, 15 architects have entered; but, contrary to the usual rule, Mr. T. Duncombe Mann, the clerk to the Board, has declined to furnish us with their names, as he thinks it would be unfair to allow individual architects to know who they are competing against. It is difficult to understand the grounds for this reluctance to give this information; but the Metropolitan Asylums Board has methods of its own! One thing is certain, and that is that someone has had access to the list of architects invited to compete, and is writing to them offering to assist them in the preparation of their designs! Whether he has had the information denied to us we cannot say. The drawings required are a block plan to  $\frac{1}{2}$  in. scale, and a plan of each floor (unless identical), with elevations and section, drawn to  $\frac{1}{4}$  in. scale. All drawings, it is provided, must be prepared by the competitors themselves or by their ordinary staff, and must be accompanied by a report and a priced statement of the cubical contents of the buildings. Designs are to be sent in without motto or device, and accompanied by a letter, sealed with a plain seal without device, to the clerk to the board on or before March 25, and both letters and designs will be numbered for identification in the order in which they are received. Three premiums of £150, £100, and £50 will be awarded, but by the objectionable rule now becoming too frequent, the first prize is merged into the lump sum which is to be paid in view of commission. The assessor, Mr. Henry Currey, F.R.I.B.A., will (i.) report whether the designs comply strictly with the conditions of the competition; and (ii.) if any design considered favourable for adoption can be carried out at the cost named by the author; and (iii.) advise the works committee generally in their selection. If, in the opinion of the works committee and the assessor, any design should not be in conformity with the conditions and

instructions, it will be rejected, and the author shall not be entitled to any compensation. The managers of the board reserve the right to reject the whole or any of the designs should they be deemed unsuitable, to make modifications in the designs adopted, and to adopt any feature from either of the premiated designs—the last condition is hardly fair to the second and third competitors. Provision is to be made for 720 patients in thirty double cottages for 24 patients each, in addition to isolation accommodation for 80 cases, and the usual administrative block, laundry, mortuary, workshops, lodge, &c.

**CRONSTADT.**—No adequate designs have been sent in for the international competition for an Orthodox Cathedral in Cronstadt, and, in consequence, a second competition will be held on the same conditions as before. The cathedral, for the especial worship of sailors, is to be built so as to hold a congregation of 4,000 people, and is to cost a maximum of 700,000 roubles. Four designs will be premiated: the first at 5,000 roubles, the second at 2,500 roubles, the third 1,500 roubles, and the fourth 1,000 roubles. These four premiated designs will become the absolute property of the Building Committee of the Russian Ministry of Marine.

**SKIPTON.**—The Skipton and District Cottage Hospital competition has just been settled, and the committee desire us to say that the award for the plans is as follows:—1st place, Mr. E. C. H. Maidman, Edinburgh; 2nd premium to Mr. W. F. Edwards, Birmingham. We are informed that the plans were all examined and reported upon by an eminent firm of architects in London, and that twenty-two competed.

### CHIPS.

From a report just published as to the work accomplished in 1897 in the Diocese of Llandaff, we learn that on the erection, restoration, or enlargement of churches in the diocese, upwards of £36,000 has been expended within the twelve-month. Further accommodation has been provided for nearly 4,000 persons.

In Bristol and the district the building trade was marked during 1897 by considerable activity, and although few buildings of great importance have been erected in the city, the trade generally has been better than for some years past. Prices have ruled slightly higher and considerably steadier. There have been no serious labour disputes. All classes have been well employed, and the supply of labour has been good.

Those who have visited the Cathedral of Dunblane have had their attention called to three blue slabs in the centre of the choir, marking, as is believed, the burial-place of three sisters who were poisoned at Drummond Castle in the reign of James IV. One of the three, Margaret Drummond, is supposed to have been privately married to the King, and it is certain she bore him a daughter, who became the mother of the fourth Earl of Huntly. On the three slabs referred to there has just been placed, at the cost of the Earl of Perth and Melfort, brasses, commemorative of the tragic fate of Margaret Drummond and her two younger sisters, Euphemia and Sybilla. "Seized with sudden illness while residing at Drummond Castle, they all three died soon after partaking of food, in great pain, and under strong popular suspicion of poison."

The restoration of Wath parish church, near Doncaster, has just been completed. Mr. Fidler, of Eckington, was the general contractor, and the work has been carried out under the superintendence of Mr. Wilfred Campsall, architect, of Sheffield.

Extensive alterations are being made by the Great Eastern Railway Company at their Chelmsford Station. Awnings 250ft. in length are to be built over each platform, new station-master's house, booking-office, &c., provided, a fresh staircase built on the down side, and the lift reconstructed.

Mr. Richard Roberts, builder, the chairman of the Building Act Committee, will not offer himself for re-election to the London Council in March as a representative of South Islington. "Private and business claims," he says, in his valedictory address issued on Tuesday, "render it impossible for me to devote in the future as much time to the work of the Council as I have done in the past." Another well-known builder, also of Welsh extraction, Mr. Howell J. Williams, at present member for Bermondsey, has been adopted by the Progressives of South Islington as Mr. Roberts' successor.

The extraordinary collection of pictures formed by Mr. David Sellar, and recently offered to and declined by the City of London, will be on exhibition at the Grafton Galleries on and after to-morrow (Saturday).

### TO CORRESPONDENTS.

[We do not hold ourselves responsible for the opinions of our correspondents. All communications should be drawn up as briefly as possible, as there are many claimants upon the space allotted to correspondents.]

It is particularly requested that all drawings and all communications respecting illustrations or literary matter should be addressed to the EDITOR of the BUILDING NEWS, 332, Strand, W.C., and not to members of the staff by name. Delay is not unfrequently otherwise caused. All drawings and other communications are sent at contributors' risks, and the Editor will not undertake to pay for, or be liable for, unsought contributions.

Cheques and Post-office Orders to be made payable to THE STRAND NEWSPAPER COMPANY, LIMITED.

### TERMS OF SUBSCRIPTION.

One Pound per annum (post free) to any part of the United Kingdom; for Canada, Nova Scotia, and the United States, £1 6s. 0d. (or 6dols. 30c. gold). To France or Belgium, £1 6s. 0d. (or 33fr. 30c.). To India, £1 6s. 0d. To any of the Australian Colonies or New Zealand, to the Cape, the West Indies, or Natal, £1 6s. 0d.

### ADVERTISEMENT CHARGES.

The charge for Competition and Contract Advertisements, Public Companies, and all official advertisements is 1s. per line of Eight words, the first line counting as two, the minimum charge being 5s. for four lines.

The charge for Auctions, Land Sales, and Miscellaneous and Trade Advertisements (except Situation advertisements) is 6d. per line of Eight words (the first line counting as two), the minimum charge being 4s. 6d. for 40 words. Special terms for series of more than six insertions can be ascertained on application to the Publisher.

Front-page Advertisements 2s. per line, and Paragraph Advertisements 1s. per line. No Front-page or Paragraph Advertisement inserted for less than 5s.

Advertisements for the current week must reach the office not later than 3 p.m. on Thursday. Front-page Advertisements and alterations in serial advertisements must reach the office by Tuesday morning to secure insertion.

### SITUATIONS.

The charge for advertisements for "Situations Vacant" or "Situations Wanted" is ONE SHILLING FOR TWENTY-FOUR WORDS, and Sixpence for every eight words after. All Situation Advertisements must be prepaid.

### NOTICE.

Bound copies of Vol. LXXII are now ready, and should be ordered early (price Twelve Shillings each), as only a limited number are done up. A few bound volumes of Vols. LXXXIX., XL., XLI., XLVI., XLIX., LI., LIII., LVIII., LIX., LXI., LXII., LXIII., LXIV., LXV., LXVI., LXVII., LXVIII., LXIX., LXX., LXXI., LXXII. may still be had, price Twelve Shillings; all the other bound volumes are out of print. Most of the back numbers of former volumes are, however, to be had singly. Subscribers requiring any back numbers to complete volume just ended should order at once, as many of them soon run out of print.

RECEIVED.—A. T. F.—I. and G. N.—H. T. W.—W. B.—R. C. and Co.—A. G.

### "BUILDING NEWS" DESIGNING CLUB.

#### FOURTH LIST OF SUBJECTS.

D.—A Small Church for a Hamlet on the Outskirts of a Town. The building to accommodate 30 and a choir of 24 voices. The site falls from W. to E. 10ft., and it is situate at the corner of two roads, with a south frontage of 160ft., and a depth of 100ft. to the second road, which runs N. There is to be a spire at the N.W. corner of the building, and the west entrance is to be through this tower, which will form a porch. There is also to be a south porch, and there may be transepts; but the building is not to be ornate, and it must be adapted to church requirements, and have a choir-vestry, as well as one for the priest. These need not be level with the church. The altar pace is to be seven steps above the nave floor, and the central passage-way up the nave is to be 9ft. wide. The organ must be near the chancel, and not be cramped in a recessed "organ-chamber," so as to impede the sound of the instrument gaining full vent. Material, coursed stone and wrought dressings. Style left to competitors. Roofs open-timbered and covered with tiles. A pulpit and screen to choir to be shown. Scale, 8ft. to the inch for one main elevation and cross-section; other drawings may be 16ft. to the inch. Sketch view desirable. Cost will be taken into consideration; but no precise sum is fixed, though an estimate reckoned at a shilling per foot cube is to be furnished with each design.

DRAWINGS RECEIVED.—"Centaur," "Wessex," "Orb," "Gib," "T-Square," "Pantile," "Don," "Derige," "Hotspur," "Suburb," "Phantom," "Erig," "The Maggot," "By Go," "Dachs," "Klondyke," "Checkmate," "Gossip," "Don't Know," "Bernard," and "Excelsior."

## Correspondence.

### A PARALLEL TO WALTHAMSTOW.

To the Editor of the BUILDING NEWS.

SIR,—With reference to the correspondence which has recently taken place between Mr. Cubitt and ourselves, we beg to say that as we have not received the requisite apology from Mr. Cubitt (some of whose statements appear to

us to be libellous), we have placed the matter in the hands of our solicitors, Messrs. Wontner and Sons.—We are, &c., SPALDING AND CROSS.  
15, Queen-street, Cheapside, E.C., Jan. 12.

WALTHAMSTOW PUBLIC BATHS.

SIR,—Mr. Dunford will not aid his case by continuing to publish untrue statements. We received no "second premium" of 25 guineas, as he very well knows, as in this competition three selected architects were invited to submit designs under the following conditions—viz., "The council will pay a fee of 25 guineas to each architect whose plans are not accepted, and an inclusive commission of 5 per cent. upon the contract price will be paid to the architect appointed to carry out the work."

As Mr. Dunford has apparently now completed his series of misleading letters, we beg to give your readers the following additional information which he has, strangely enough, omitted to supply—viz.:

(1) Long before Mr. Dunford's name was suggested in connection with the proposed work, we were practically engaged by the council to prepare the necessary working drawings for the Public Baths. However, one of Mr. Dunford's friends moved and carried, at the last meeting of the council, a resolution to the effect that "before the council sealed the appointment of Messrs. Spalding and Cross, the various public bodies for whom these architects had erected public baths should be communicated with, to ascertain what were the original estimated costs of their baths, and what was the final expenditure incurred." Although replies to these questions were received in due course, the inevitable delay which had been caused had the effect desired by Mr. Dunford's friend, and our appointment was not sealed as the incoming council contained a majority of Mr. Dunford's supporters.

(2) This new council instituted a competition for the work, and appointed Mr. Rowland Plumbé the assessor. After Mr. Plumbé's report was received by the works committee it was unanimously decided that we should be "requested to appear before the next committee, and pledge ourselves to erect the baths for the sum named." When this recommendation was submitted to the council a few evenings after, the same active supporter of Mr. Dunford who had prevented our appointment being sealed by the first council, notwithstanding the fact that he had supported the works committee's unanimous recommendation, actually moved and carried an amendment to it, to the effect that Mr. Dunford be appointed architect to the public baths, and that his appointment be sealed by the council.

3. The third council at once rescinded the resolution carrying Mr. Dunford's appointment, on the ground that it was obtained by "a gross act of jobbery."

We may add that we have never been told by anyone but Mr. Dunford that his plans were "placed first in the competition"; indeed, the works committee's action after Mr. Plumbé's report was received, appears to us to clearly show that if our estimate could be justified, there was no doubt in the assessor's mind as to the respective positions of the two designs.

We do not know to what extent these machinations on the part of his principal supporter were approved or instigated by Mr. Dunford; but we do know that he was prepared to benefit by the results they achieved.

In conclusion, we assert that Mr. Dunford has published misleading and, in some cases, untrue statements in the BUILDING NEWS and elsewhere relative to our own and his own actions in connection with this competition. We have recently seen a very explicit article upon the facts connected with this appointment which appeared some time since in the *Walthamstow Reporter*, in which the two successful efforts made by Mr. Dunford's friends to out us from the appointment are fully described.

We understand that no attempt has been made to refute the statements contained in that article.—We are, &c., SPALDING AND CROSS.

TIMBER.

Sir,—While thanking "A. H." for his endeavour to reply to my letter of the 10th ult., I regret that he has not enlightened me on the matter beyond strengthening my opinion that red and yellow deal are the self-same wood and from the *Pinus sylvestris*. I fail, however, to see how

the names "fir," "pine," and "deal" are each distinguished by the colours red and yellow when he says they all apply to the one tree. It is not likely that the foresters or timber exporters, who know the tree and the red colour of its bark, would term it "red" when the floorboards which are imported ready for laying are termed "yellow." Many carpenters profess to know the difference between red and yellow deal, and although I was at one time a bench hand in the "lang toon" of Kirkcaldy, I must confess my inability to do so.

I am likewise indebted to Mr. Stevenson, whose letter in last week's issue is not only more to the point, but very interesting. It is to be regretted, however, that both he and "A. H." give up the classification of this chaotic subject as hopelessly beyond human enterprise. If, botanically speaking, the tree is a pine, and is not popularly known as such, then we are, and have been all along, in a state of confusion, which confusion, Mr. S. remarks, is part of our language, and cannot be set aside. It is quite evident that the reaction of the rectification of the wrongs at present so deeply rooted must again cause confusion; but that is no reason why—if even only for the guidance of students—we should not strive to adopt a clear and unmistakable classification instead of hazarding the recurrence of another "Babel" calamity. If a carpenter or joiner does not know the botanical name of the wood he is using, then I say the sooner he does know the better. Is it not preferable to be precise in its classification than to be ignorant of it? Mr. S. has slightly misunderstood me. I did not say, nor do I agree with him in saying, that the term "yellow" deal is almost exclusively used in the textbooks, but that the term is almost exclusively applied to floorboards. Taking the majority of textbooks, you will read, for instance, "lin. deal this and 1½ in. deal that," without any distinction as to whether it may be red, white, or blue; but when you come to floorboards you can't get away from it, for there it is, "1½ in. yellow deal floorboards."

Speaking of the balk timber. You neither read of it as red or yellow fir nor find its name derived from its colour, but from the ports of shipment, as Memel, Dantzic, Riga, &c. This also adds to the confusion, and would be overcome if my suggestion were adopted. What is at present termed Dantzic, Memel, and Riga fir balk, or red and yellow deals converted, would simply be "Northern pine," *Pinus sylvestris*, and this ought not to be mixed up with quite a different wood, which in this country is called yellow pine, *Pinus strobus*, and in America, its native country, white pine.

My suggestion of wiping out these old terms or landmarks may be chimerical or Utopian, as Mr. S. puts it; but my reverence for old usages and landmarks is too great to advocate their being swept away, unless, as in this case, they become misleading and dangerous. When terms become confusing in their analysis, and conflicting in practice, it is high time to suggest a reformation, and the only obstacles which may render my suggestion impracticable are the indifference of those who would otherwise adopt it, and the tenacity of those who either do not care to change, or may not realise its ultimate advantages.—I am, &c.,

D. FORBES SMITH.

8, Cann-street, Taunton.

Sir Charles Hutton Gregory, K.C.M.G., died on Monday at his residence, Duchess-street, Portland-place, aged 80 years. He was President of the Institution of Civil Engineers in 1868 and 1869. Sir Charles served in many public capacities connected with his profession. He was employed abroad as consulting engineer for railways to the Colonies of Ceylon, Cape of Good Hope, Trinidad, and some of the Malay territories. In 1894 he married Mrs. Stirling, the famous actress, who died in the following year.

On Tuesday evening the employés of Messrs. Swaine Bourne and Son, King Edward's-road, Birmingham, sat down to a repast, when mutual congratulations were exchanged upon the satisfactory friendliness and good feeling that existed between them—from several for a period of 20 years and more. Congratulations as to the position of the sick club were also made as to its financial position, being able to carry a substantial balance forward. Discussion arose for the further augmenting the annual Hospital Saturday collections by making provision weekly. The meeting concluded by the exhibition of limelight views of buildings, works of art, &c., which were shown by Mr. Kendrick Swaine Bourne by the aid of a biennial lantern, the above taking place at the stained glass works.

Intercommunication.

REPLIES.

[11862.]—Strength of Cast Iron.—A socketed-joint machine planned would do to unite the iron columns, as the girders bolted to the column brackets would hold them upright. As to the strength of cast-iron bracket, in the case of a girder end resting, the weight of which would be 13 tons, I should prefer a capital, the girder resting partly on the shaft below. A cast-iron bracket would be subjected to a shearing stress, and no rule would be reliable. A wrought-iron bracket or triangular bracket, consisting of a horizontal member bolted to the stanchion and a strut underneath, would be a stronger and more reliable form, and the distribution of stresses on both these members can be found graphically, the first being calculated for tension and the strut for compression. If of cast iron, the web should be 2 in. to 3 in. thick, and be of sufficient depth to act in compression; but there is always the risk of fracture or air-holes in the metal.—A. L.

[11880.]—Quantities.—An architect is not compelled to supply his committee with a copy of quantities, and he may refuse to do so, as they are only supplied for tendering purposes, and for the information of the builder. The architect usually retains the bill of quantities, and if a client asks to see it, he may do as he pleases, though it is not necessary or politic that he should do so. The quantities are generally regarded as part of contract: any error or deficiency, the quantity surveyor is liable for to the owner. Sometimes the quantities are prepared by the architect. Occasionally the condition is inserted that the priced bill shall be deposited by the contractor, and this is the most desirable procedure.—METEOR.

[11881.]—Floor Calculation for Loads.—By making a plan of a floor 60ft. square, with the positions of the two main girders and the columns supporting them, it will be easy to compute the load carried on each beam. Drawing through the centres of the four columns lines parallel to both walls, it will divide the area into nine parts or squares, each about 20ft. square. One of the girders will carry an area 20ft. by 20ft., or 40 sq. ft., and if we say the load on each square foot is 4cwt., then the load on each of these areas of 400sq. ft. will be 1,600cwt., or 80 tons. This will be equal to a distributed load on each third of the girder on the columns of 80 tons, or on the whole girder of 60ft. long of 240 tons. The other main girder will carry the same load. Of course, the columns divide the length into three parts, and each part may have a girder proportioned to it, or 80 tons distributed.—G. H.

CHIPS.

Between 4,000 and 5,000 persons visited on Sunday afternoon the Passmore Edwards Art Gallery and Technical Institute in Peckham-road, opened on the previous Thursday by Sir E. D. Poynter, P.R.A.

A new hotel is in course of erection at Felixstowe for Messrs. Tollemache Brothers. The contractor is Mr. Fred. Bennett, of New-street, St. Clement's, Ipswich.

Mr. Harry Hems, of Exeter, is leaving England at the end of this month for Pietermaritzburg (Natal), for the purpose of being present at the wedding of his third son, William.

Sales amounting in all to £17,285 were held during last week at the Estate Mart, Tokenhouse-yard.

Mr. Henry Charles Heath, of Pall Mall East, miniature painter to the Queen, died at his residence, Greencroft-gardens, South Hampstead, on Thursday in last week, in the 74th year of his age.

At Malpas, a new organ, built by Messrs. Lewis and Co., of Brixton, S.W., at a cost of £350, was opened at the parish church on Thursday in last week.

A memorial is being raised by past and present members of Jesus College, Oxford, and other friends to the late Rev. Llewelyn Thomas, Vice-Principal and Fellow of that college, who died on May 12 last, almost immediately after he had been appointed Canon Residentiary of St. Asaph Cathedral by the Crown. It is intended that the memorial shall take the form of a window in the college chapel.

The building trade in Hull was unusually brisk during the past year, and almost every part of the city shows increased signs of the march of the builder. Land is improving in value, but the price is still low. Materials have been dear, and in some cases difficult to obtain. The speculating builder has found the Hessle-road district the most suitable for his operations, and certainly the most lucrative.

The Corporate Property Committee of the Leeds City Council have decided that all the unsold land on the east side of Victoria-avenue, Ivy House Estate, containing an area of 40,629 square yards, be sold to the sanitary committee for the purpose of the erection thereon of dwellings for the accommodation of persons displaced by insanitary area schemes, at the price of 1s. 9d. per square yard.

At Friday's meeting of the Driffield Board of Guardians, a letter was read from Mr. Jos. Shepherdson, architect, Driffield, asking the indulgence of the board for a time in the matter of the new workhouse infirmary, the plans for which had been burnt in the fire at his house on Christmas morning.

## CONTENTS.

Professional Grievances ..	51
Industrial Democracy ..	52
Wrought Iron and Steel in Constructional Work.	
—XXXIII. ....	53
The Surveyors' Institution ..	55
Builders' and Sanitary Fittings ..	55
Obituary ..	56
Building Intelligence ..	56
Engineering Notes ..	57
Competitions ..	58
Correspondence ..	58
Intercommunication ..	59
The BUILDING NEWS Directory ..	IX.
Our Illustrations ..	60
Architectural and Archaeological Societies ..	60
Legal Intelligence ..	67
Water Supply and Sanitary Matters ..	78
Our Office Table ..	79
Meetings for the Ensuing Week ..	79
Latest Prices ..	79
List of Competitions Open ..	80
List of Tenders Open ..	80
Tenders ..	82

## ILLUSTRATIONS.

HIGH SCHOOL FOR GIRLS, SHREWSBURY. — "SPRING":  
ROYAL ACADEMY PRIZE DESIGN.—MOBBERLEY CHURCH,  
CHESHIRE.—NEW BANK, LOUGHBOROUGH.—BRONZE  
MEMORIAL TABLETS OF LEIGH HUNT AND CHARLES  
KEENE.—"THE HEDGEHOG" INN, NOTTINGHAM.

## Our Illustrations.

HIGH SCHOOL FOR GIRLS, SHREWSBURY.

THIS building, for day-scholars only, is erected partly on and below the old town walls, the level of the ground being some 15ft. below the street, sloping rapidly away at the back. This has allowed of an upper and lower ground-floor plan, the pupils' entrance to the latter being by a sloping way under the main entrance from the street. The assembly hall is 33ft. high, with corridor and gallery on three sides. The elevations are faced with "Heather" Leicestershire bricks, relieved with stone bands and oak framing. The gable of porch contains the sign and motto of the Company: "Knowledge is now no more a fountain sealed." Mr. A. E. Lloyd Oswell is the architect.

"SPRING."

THIS is the cartoon of the principal group in a design which gained the prize (£40) for Decoration of a Public Building at the Royal Academy Schools in December. The design, of which this is a part, is to fill a lunette with a door cut in it, being the shape of one of the spaces still undecorated in the walls of the refreshment-room at the Royal Academy. The group herewith reproduced from the full-size cartoon is the central group of the whole design, and represents Spring as an infant standing in the lap of Mother Earth with outstretched arms towards the groups of attendant girls on either side, who do not come in the cartoon.

ELEANOR F. BRICKDALE.

MOBBERLEY CHURCH, CHESHIRE.

THE Priory of Mobberley, an establishment for regular canons founded in 1206, has long enough ceased to exist. The piscina and sedilia in the church are the only remains now existing, and they consequently give some interest to the sanctuary, which is divided off from the roof by a quaint rood loft. There is a painted parchment monument to Thomas Mallory, the possessor of the Old Hall in 1713, whose memorial has been decorated to look like marble. There is also a brass in the church to James Stanley, 1674; but the building gains its chief interest by its picturesque situation, and this Mr. Walter Prince has realised in the accompanying pen-and-ink study of the old square tower and wicket to the churchyard leading up from the roadway.

HAMMERSMITH PUBLIC LIBRARY: LEIGH HUNT AND CHARLES KEENE MEMORIAL BRONZE TABLETS.

WHEN Mr. Passmore Edwards presented the Public Library which he built at Shepherd's Bush to the parish of Hammersmith, the building\*

\* Illustrated in the BUILDING NEWS, March 29, 1895. Gable Sculpture of Shepherd in the Bush, in BUILDING NEWS, March 13, 1896.

was dedicated to the memory of two very distinguished men who for years resided in the parish, and besides erecting a memorial cartouche on the exterior of the building, Mr. Passmore Edwards also commissioned Mr. George Frampton, A.R.A., to execute two bronze portraits of Leigh Hunt and Charles Keene. These have been placed in the entrance-hall of the library, and are set on Seina marble slabs, pleasingly-shaped in outline, making exceedingly artistic and valuable additions to the building. We illustrate both tablets to-day. That of the great *Punch* artist was exhibited by Mr. Frampton at the Royal Academy, and both are admirable portraits. Few of our readers have any idea probably that Charles Keene sketched architectural subjects; but we hope at an early date to be enabled to give one or two typical examples promised us by Mr. Fisher Unwin when we notice his monumental volume "The Work of Charles Keene," by Mr. Joseph Pennell, just published.

THE LEICESTERSHIRE BANK, LOUGHBOROUGH.

THE new premises of the Leicestershire Banking Company, Limited, occupy a commanding position in the Market-place, all the bank offices being placed upon the ground floor. Above them



are suites of private offices, and a caretaker's residence. The plinth is of polished red granite, above which the front is of Portland stone. The general contractors were Messrs. Moss and Son, of Loughborough, and Messrs. Goddard and Co., of Leicester, are the architects.

"THE HEDGEHOG" INN, NOTTINGHAM.

THE above has been rebuilt on the site of the old inn in Camoch-street with red sand-bricks, stone facings, tiled roofs, with heavy wood cornice at eaves and leaded lights. In excavating, the builders found the old town wall and bed of the old moat or "leen." The architects are Messrs. Brewill and Baily.

Thursday next is fixed for the dedication of the Battenberg Memorial Chapel in Whippingham Church. The Bishop of Winchester will be the officiant, and the Queen is expected to be present.

The council of the Honourable Society of the Cymmrodorion, in response to a request by the Prince Llewelyn Memorial Committee that the society should undertake excavation work at Abbey Cwm Hir, with the object of discovering the grave of "Llewelyn Ein Llyw Olaf," has appointed a committee to report upon the best means of carrying out the scientific exploration of the abbey ruins.

A Bill to incorporate the Bideford and Clovelly Railway Company has been deposited at the Private Bill Office. The proposed company seeks power to construct a railway ten miles three furlongs in length, commencing in the parish of Abbotsham by a junction with the authorised Bideford, Westward Ho, and Appledore Railway, and terminating at Clovelly. The railway may be constructed and worked as a light railway on a gauge of 3ft., but with power to increase the gauge to the usual width of 4ft. 8½in. The capital proposed to be raised for the construction of this line is £50,000.

A Bill to incorporate a company for the purpose of constructing a railway from Windsor to Ascot has been deposited at the Private Bill Office. The proposed railway, which will be just over 10 miles in length, is intended to commence by a junction with the Windsor branch of the Great Western Railway, and to terminate at Sunninghill by a junction with the Ascot and Aldershot branch of the South-Western Railway Company. In connection with this railway it is proposed to construct a road leading to the entrance to the Ascot grand stand. The capital proposed to be raised is £549,000.

## ARCHITECTURAL &amp; ARCHÆOLOGICAL SOCIETIES.

THE ARCHITECTURAL ASSOCIATION OF IRELAND.—A general meeting of this association was held in the Grosvenor Hotel, Dublin, on Jan. 6. The president delivered a lecture on the "Artistic Treatment of Architectural Perspective." He illustrated his remarks by reference to original drawings by Messrs. J. Raffles Davison, J. Coleman, C. W. English, and himself, lent by various architects. The lecturer also showed some etchings, pointing out the error into which many draughtsmen fell, that of imitating the methods of the etcher. He also laid stress on the almost invariable neglect of tone in architectural drawing, whereby much work, otherwise of considerable merit, was spoilt.

## CHIPS.

The Canadian Pacific Land Department sales for 1897 show the largest increase on record, 200,000 acres being sold for 650,000dol., while in 1896 only 88,000 acres were disposed of for 307,000dol.

Probate has been granted of the will of Mr. John Bagnold Burgess, R.A., of 60, Finchley-road, who died on November 12, and the value of whose personal estate has been sworn by the widow at £24,500.

At St. Barnabas' Church, Ashley-road, Bristol, under the direction of Mr. F. Bligh Bond, a new pulpit, low screen, altar-rail, and other improvements in the sanctuary and choir have been carried out. A special dedication service has been held by the Lord Bishop of Bristol.

Since May, 1894, when the Building Fund for the Westminster Cathedral was started, £64,114 has been subscribed. Promises representing another £18,000 have also been received, making a total up to date of £82,914. Of this sum £34,964 has already been expended upon the building, under Mr. J. F. Bentley's direction, and from his plans, leaving £29,147 in the bank. The total cost of the structure will be about twice the sum which has been subscribed at present.

The last of the cob-walled and thatched-roofed chapels in Cornwall, that belonging to the Bible Christians at Trelyon, is about to be modernised and provided with a more permanent covering.

The past year has been an unwontedly busy one in Sheffield. The number of plans submitted to the city council for approval for houses, saleshops, and property of every description has been 1,429, and the number of houses sanctioned in the plans has been 2,320, while 480 other proposed buildings have been approved.

A new Jubilee tenor bell has been dedicated at St. Martin's Church, Broadwater Down, Tunbridge Wells. It weighs 11½cwt., was cast by Messrs. Taylor, of Loughborough, and replaces one of 6½cwt., cast by another firm in 1866, and which was impaired in tone.

The tower and baptistry which the congregation of St. Martin's Church, Potterneton, Leeds, have erected as a memorial to the late vicar (the Rev. R. G. P. Bullock) were dedicated on Thursday evening in last week by the Bishop of Ripon. The tower is 50ft. in height, and 16ft. square inside.

A feu has just been taken off at Drymen, N.B., for the erection of a Cottage Holiday Home for the Scottish Girls Friendly Society. This home is to be built by Mr. and Mrs. William Ewing Gilmour, in memory of their deceased eldest daughter, and will be named, "The Jessie Campbell Gilmour Cottage Holiday Home." The building will cost about £3,000.

The Victoria Library, which is the new branch at Heaton to be presented to the city of Newcastle-on-Tyne by Alderman W. H. Stephenson, is now in progress, and expected to be completed about midsummer next. It is being erected by Messrs. J. and W. Lowry from the designs of Mr. Dyson, Gray-street, Newcastle.

The building trade in Leeds was very busy during 1897. The new houses approved rose to 2,062, as compared with 1,570 in 1896 and 1,122 in 1895. The new factories built were 63, as contrasted with 36 in 1895; while the aggregate number of plans passed was 3,252, as compared with 2,082 in 1895—a leap of over 50 per cent. During the year the estimated population rose from 198,659 to 203,599, and the rateable value from £731,457 to £755,798. The year witnessed the opening of the Municipal Technical and Art Schools, which had been built at a cost of about £50,000. At their successive meeting, the corporation voted £68,000 for an addition to its lunatic asylum, £68,000 for the extension of the gasworks, £30,000 for a public park, £55,000 for an infectious hospital for 160 patients, £30,000 for an extension of the electric lighting plant, and about £60,000 more for street improvements, baths, branch libraries, and destructors.







"PHOTO-TINT" BY JAMES AKERMAN. ARTIST: T. J. BROWN. 1913.

"SPRING" ROYAL ACADEMY PRIZE DESIGN FOR THE DECORATION OF A PUBLIC BUILDING BY MISS MARY E. BRICKDALE

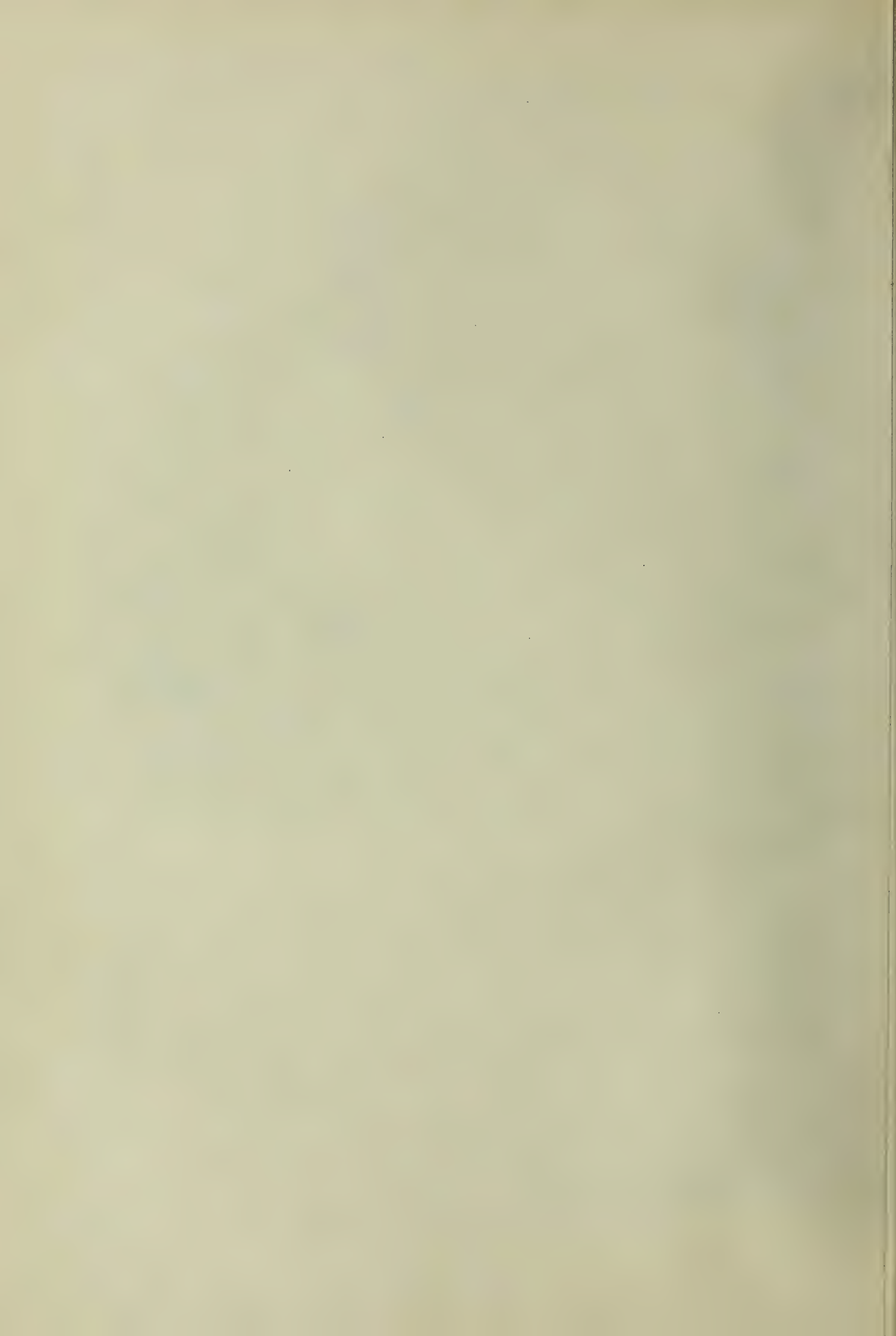







Upper Ground Plan.

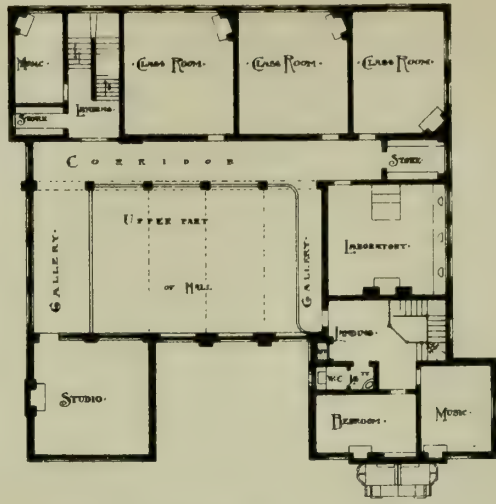

First Floor Plan.



HIGH SCHOOL FOR GIRLS  
& SHREWSBURY  
A.E. Lloyd Oswell, Arch<sup>t</sup>

C.W.S. det<sup>d</sup>  
97



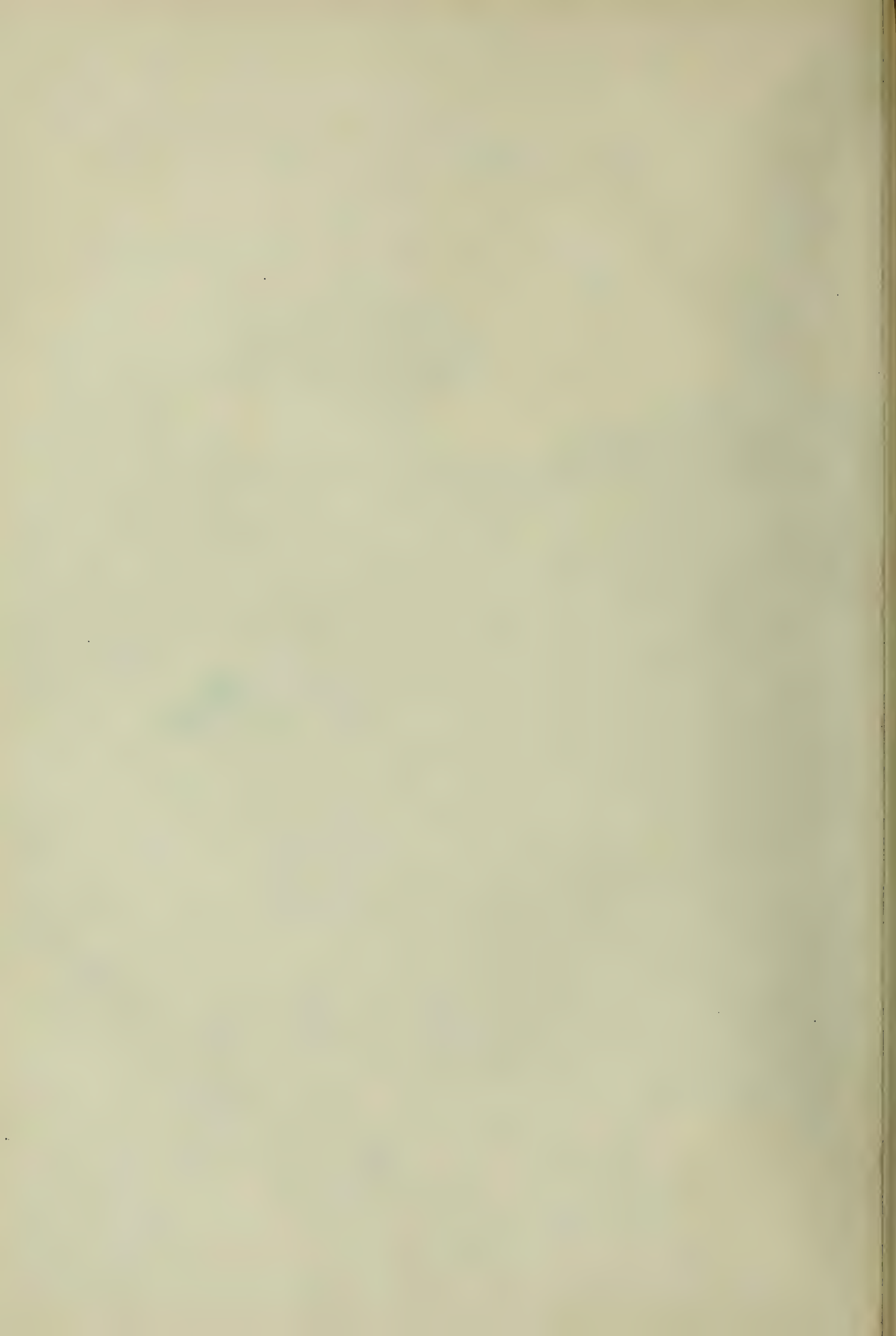





WALTER PRINCE.

Photo Lithographed & Printed by James Akeeman, 6, Queen Square, W.C.

MOBBERLY CHURCH, CHESHIRE, BY WALTER PRINCE.



"PHOTO-TINT" by James Akerman, 6, Queen Square, London, W.C.







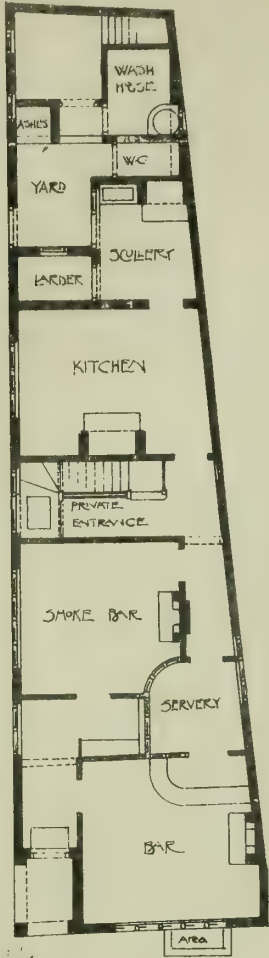

GROUND PLAN

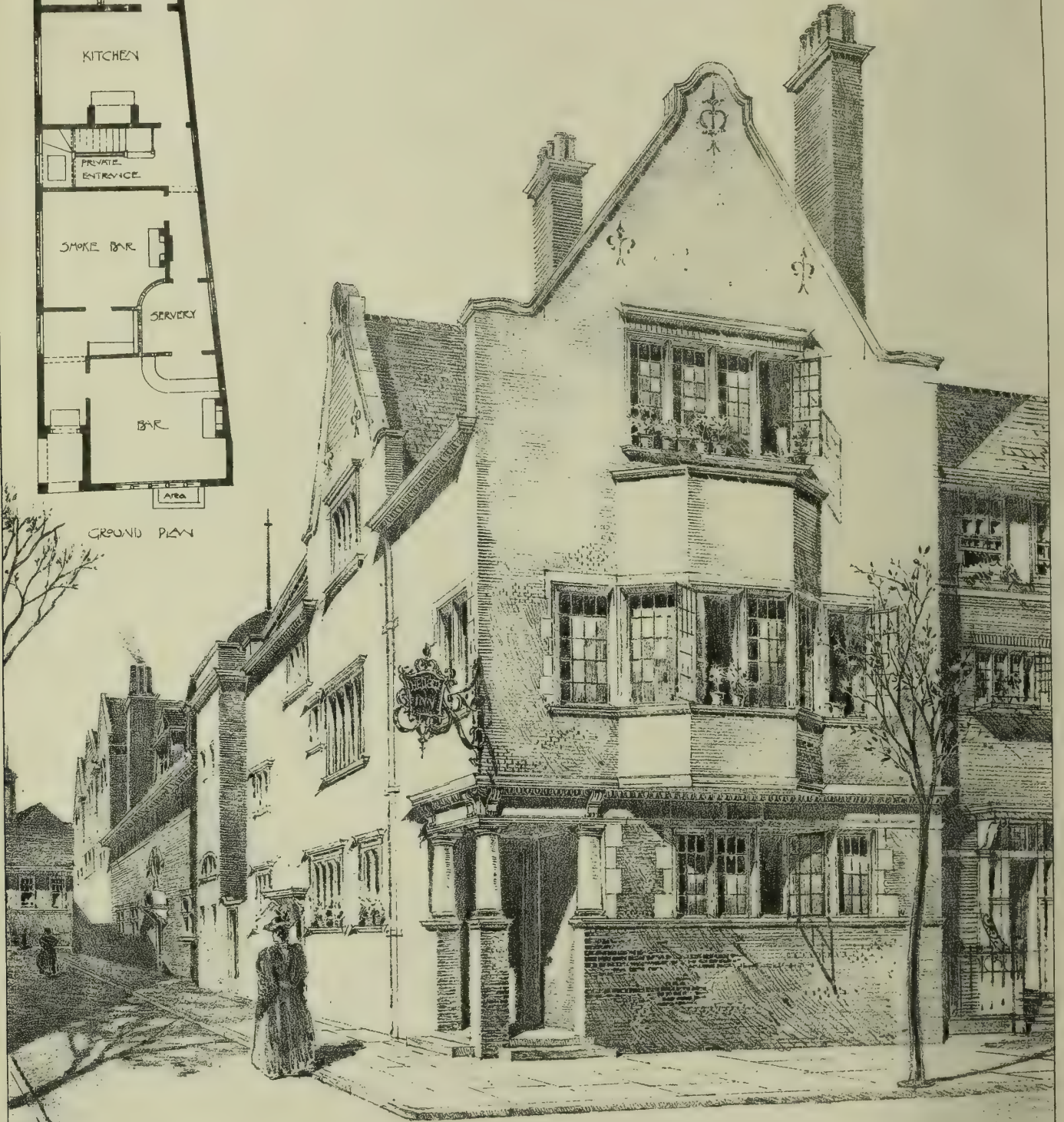

THE HEDGEMOG  
INN  
CANAL ST  
NOTTINGHAM

BREVILL &  
BAILLY  
ARCHTS



BURKE DOWLING '98

Photo Lithographed & Printed by James Akers, 6, Queen Square W.C.

NEW BANK · LOUGHBOROUGH · FOR THE LEICESTERSHIRE BANKING COY · LD · :

MESSRS GODDARD PAGET & GODDARD ARCHTS



## LEGAL INTELLIGENCE.

OVER A HUNDRED SUMMONSES AGAINST A BUILDER.—At West London Police-court on Saturday Mr. Rose disposed of a batch of 105 summonses against Mr. Joseph Wilson, a builder, issued at the instance of the London County Council with reference to the erection of 21 houses in Stephendale-road, Fulham. The complaint against the defendant was that he had used in the erection of the houses bad mortar and bricks, and had been guilty of other offences under the Building Act. Mr. Seager Berry, who represented the Council, said the defendant had carried out remedial works, and was doing all he could loyally to complete them. Mr. Macmorran, Q.C., for the defendant, agreed to the arrangement, but mentioned that the remedial works had cost him £1,000, which was rather hard upon him, as the houses were erected under the supervision of the district surveyor. Mr. Rose then fixed nominal penalties in each group of summonses, amounting in the whole to £4 4s., with 18 guineas costs.

THE BUILDING OF A WORKHOUSE: DREW-BEAR V. THE ST. PANCRAS GUARDIANS.—Another case has been reached in this protracted arbitration case this week, when the action came once more before Mr. Justice Ridley sitting in the Queen's Bench Division. We reported the earlier phases of the case in our issues of July 17 and 24, and November 20 and 27, 1896 (pp. 98, 133, 755, and 769, Vol. LXXI., and January 22 and 29, March 5, 12, and 19, 1897, pp. 149, 185, 365, 379, and 413, Vol. LXXII.), when it was originally heard at the Old Bankruptcy Court, Portugal-street, W.C., before Mr. Edward Ridley, Q.C. (as he then was, now the Hon. Sir Edward Ridley, one of the Judges of the Queen's Bench Division) sitting as Official Referee. It was, it will be remembered, brought by several builders' merchants, suing as trustees of creditors of Mr. William Brooks, of Folkestone, builder, against the Guardians of the Poor of St. Pancras, and their architects, Messrs. A. and C. Harston, for a balance of £24,226, or alternately £24,265, alleged to be due on a building contract for the completion of St. Pancras Workhouse. The case for the plaintiffs was that some years ago the St. Pancras guardians resolved to reconstruct their workhouse premises in King's-road, Pancras-road, and appointed Messrs. Arthur and Christopher Harston, of Leadenhall-street, E.C., as their architects. The original contract for certain sections of the work was undertaken by Messrs. Kirk and Randall, of Woolwich. Disputes arose, and in 1892 Messrs. Kirk and Randall desired to be relieved of further duties under the contract; fresh tenders were invited for the completion of sections 1 and 2, and that of a Mr. William Brooks, of Folkestone, was accepted for £50,861. Brooks's contract was to have been completed in 15 months from May, 1892; but delays arose, and in November, 1894, the work was stopped. Messrs. Drew-Bear, Perks and Co., 71A, Queen Victoria-street, E.C., who supplied the ironwork, Mr. Henry Tolputt, of Folkestone, who supplied the timber, and Mr. James Brown, of Cannon-street, E.C., and Braintree, who supplied some of the bricks, then sued as trustees of the creditors of William Brooks for £24,226, or alternately £24,265, balance alleged to be due to Brooks. After a hearing extending over 24 days, the Official Referee gave judgment on March 17, 1897, for plaintiffs as against the guardians, the damages to be ascertained hereafter, and for the architects as against the plaintiffs with costs. Against this an appeal was made by the guardians to a Divisional Court, and was heard by Justices Grantham and Wright on April 13 last year (see p. 579 in our issue of April 16 last). They decided that the judgment as against the guardians ought to be set aside, and that the case should be re-tried before another Referee. The plaintiffs in turn appealed, and the Court of Appeal, consisting of the then Master of the Rolls (Lord Esher) and Lords Justices A. L. Smith and Chitty, as reported in the BUILDING NEWS for May 21, p. 737, reversed the judgment of the Court below, Lord Esher remarking that the judges had "given a decision which was absolutely wrong." The Court of Appeal further ordered the case to be remitted to Mr. Justice Ridley, as he now was, to decide the amount of such damages as could be proved to be the result of delay in gaining possession of the site, and of interference by other contractors. In November, counsel for the defendant guardians again appealed to Lords Justices A. L. Smith, Rigby, and Henn Collins to allow the case to go before another Referee, as Mr. Justice Ridley would not be able to take it; but, as reported in our issue of Nov. 5 last, p. 670, the application was refused, their lordships practically saying—although, of course, not in so many words—that no other referee could be expected to disentangle so complicated a skein, and that if their brother Ridley had not time, he must make time to settle the matter. The action accordingly came on for hearing once more in Queen's Bench Court No. 2 on Tuesday, and is still in progress as before; and on the opening the learned judge said that the case must be finished this week, and that if necessary he should sit till a late hour on Saturday to conclude the hearing. Mr. Reginald M. Bray, Q.C., appeared for

plaintiffs, and Mr. English Harrison and Mr. W. Moyses for the defendants. Mr. Bray, in opening the case, recounted the facts, which were probably pretty familiar to the learned judge. Mr. Bray explained that the heads under which damages were now claimed were as follows:—A. and G., in consequence of the contractor not being able to have full possession of the site, and not being allowed to continue in possession thereof, and the failure to get possession of Block A within six months from the date of the contract, caused the labour to exceed what should have been its proper cost by at least 25 to 30 per cent., being an excess on the whole of the contract of from 10 to 12½ per cent., exclusive of any rise in the price of labour or any excess of price paid for materials from same cause was, say, 12½ per cent. on the price paid. This labour was reckoned by the plaintiffs' accountants at £28,631, and by the defendants' experts at about £26,000; but for plaintiffs' purposes of claim the former sum was assumed, the item of damage under this head thus working out at £6,357. For the increased price of labour paid to men from and after September 1, 1893, when there was a general rise in wages of a halfpenny an hour, another £1,210 was claimed, plus £121, the 10 per cent. profit which a contractor looked to obtain. A further sum of £1,000 was claimed as loss sustained by the contractors in making good work injured by such delays, and interference by sub-contractors. Under B, £1,555, plus 10 per cent. profit, was claimed for increased cost of materials from 1st September, 1893, occasioned by the general rise in prices, and under C and D, £3,814 was claimed as establishment charges, increased loss on plant, and cost of supervision, being 7½ per cent. on the contract. Under head E, 1½ years' pay at £1,000 a year, or £1,250, was claimed by reason of the contractor being obliged to give his attention to this undertaking for 18 months longer, owing to delay, than was originally estimated and allowed. Head F, dealt with the fact that the contractor had to employ additional capital over a much longer period, involving increased interest on considerable sums of money remaining idle, and for this a further sum of £1,250 was claimed. The last head, H, was a claim of £160, being 10 per cent. for the loss of profit on the portion of contract for chaplain's room, &c., which had been estimated to cost £1,600. These items, under the several heads A to H, amounted in all to £16,872. The first witness was James Brown, builder, of Cannon-street, E.C., who on being sworn said he had carefully gone into the estimates of damages occasioned by alleged breaches of contract. The first item, £6,357, was set down for increased outlay caused by increased price of labour due to difficulties in working. The most important factor in such a contract was that the contractor should be given uninterrupted possession of the entire site. In this case the area was comparatively limited, and there was a considerable rise towards the north-east. It was, therefore, almost impossible for a builder to commence operations except in one way—namely, to secure several entrances at the lowest point, and be able to level the whole site down to a common plateau. This would save expense and labour, and would enable the foreman to keep his men together. Witness had not a doubt that the contract sum was amply sufficient to complete the work. The conditions on which the contractor was asked to begin on Block C were impracticable. The fact that the mortar-mill had to stand on a mound 7ft. or 8ft. high was most inconvenient. As the old buildings were pulled down there was absolutely no space on which to stack or sort the old materials, portions of which were to be reused in the new works. Moreover, the builder was confined to one out of four blocks, so that the men could not be shifted to a second block in case of any stoppage. He estimated that the labour bill for work carried out in this fashion would cost at least a third more than if done in ordinary way. Mr. Bray: Suppose, for the sake of argument, that the agreed amount of the labour bill is £28,631, what would be the amount of damage? Mr. English Harrison objected to any question of figures being gone into, and in the course of a heated argument it transpired that the defendants claimed that the labour bill should be only £26,000, certain items of joinery done at Folkestone being objected to. The learned judge overruled the objection, and urged that both sides could surely agree on such a matter of figures as a labour bill. Witness, continuing, said it would not be a third of the amount, as certain items would not be affected, reducing the total to, say, £22,000. He estimated the extra cost roughly at £7,000; but if the sum claimed by plaintiffs was £6,370, that would not be an over-estimate. While the works were in progress, there was in May, 1893, a rise of a halfpenny an hour in various works, and also in materials; these, of course, added to the cost. Passing on to the condemnation of columns in blocks C and H, the witness said if the builder had had possession of all blocks, the condemnation of iron columns in one block would not have materially delayed the work, nor have made any difference except inconvenience.

The whole of K block was carried out as an independent work after the blocks in front of it had been completed, and this clearly added to the expense. To these items should be added the profit of 10 per cent. which a contractor hoped to gain, and which should have been more on this undertaking. Witness also referred to the delay caused by the well-sinking, which precluded the builders from getting on with the work; more time was lost in the diversion of water-mains from the site, while blocks C and H were cut about by the independent hot-water fitters. He estimated the damage accruing from these three sources at £1,000. As to increase in establishment charges, witness's experience over many years was that they should come to 5 per cent.; but in this case, owing to delay, they would be doubled within a fifth, or say £2,000. The plant should have done two such jobs; but to double the time was equal to its use on two contracts, and he should add another 2½ per cent. for this item, and something more should be put on for supervision. Another 10 per cent. profit had to be allowed on the chaplain's house, which was not carried out by the contractor, and which building had been estimated at £1,600; certainly another £160 should therefore be allowed for this item. A further sum of, say, £1,000 a year should be allowed a contractor if he was kept on such a contract 2½ years instead of 15 months. When the trustees took on the contract, materials valued at £4,000 were taken over, and a large proportion of these materials was held over owing to delay, and this continued all through the contract. For this and the delay in paying over the retention money another £1,250 should be allowed. Witness was cross-examined by Mr. English Harrison with a view to show that the difference in levels between the available entrance and the point witness would have preferred was not so great as had been suggested. Many of the old buildings were pulled down before witness saw the site. The point was that the contractor had but one entrance, whereas there should have been three or four, and at the least two. Passing on to the work of construction, witness said that two blocks ought to have been in progress at the same time. He was asked whether much of the delay in the later portion of the work was owing to the action of the architects or the clerk of works (which the Court of Appeal had decided must not be taken into account), but witness said he had also allowed for this in making his calculations. He could not give the exact figures on which he based his calculations; they were founded on experience as a builder of between 40 and 50 years. Three per cent. would be an insufficient allowance for establishment charges. Even if Brooks left the supervision to his manager, Fearon, he was entitled to be paid for supervision, because while the St. Pancras job was going on he was prevented from undertaking other work. In witness's business many works were carried out from beginning to end without his ever seeing them, and that was the *modus operandi* with all builders in a large way. Re-examined: The trustees of the creditors took the place of Brooks during the latter part of the job, and found the money for it. Thomas Lawrence Fearon, manager to Brooks, said if he had had possession of the whole site from the first, he should have put a hoarding round the whole as per contract, and should have made entrances as required, and should have excavated the whole site to the required levels. The total labour bill was £28,631, of which about £2,000 was for joinery done at the Folkestone shop, and with other deductions, the bill would be about £22,000; he should put down the loss owing to delay and interference at about 20 per cent. on this £22,000. Witness gave particulars of the alleged interference with the work by independent sub-contractors. After September 1st, 1893, when the works should have been completed, there was an all-round rise of 10 per cent. on all materials and labour due to advances granted in the May of that year; of course, all increases of wages and in cost of timber, boards, slates, and bricks which occurred between May and September, while the contract was in progress was, as usual, borne by the contractor. The total amount, as shown in many cases from invoices produced, was £1,550, and on this he was entitled to another 10 per cent. as profit, or £155. He had estimated the establishment charges at 3 per cent., and this should be charged for all the additional time involved. Mr. English Harrison said he objected to the whole of this evidence, as it necessarily included the delays due, as was admitted, to the acts of the architects and their clerk of works, and by the judgment of the Court of Appeal he submitted that his lordship was prohibited from going into any question as to the consequences of the architects' acts. The learned judge said he should not allow the judgment of the Court of Appeal to hamper him in trying the case. The commonsense plan, and the one which he meant to follow, was to hear the evidence as to all delays and interference, and to make a deduction for everything due to the acts of the architects and their clerk of works, allowing the plaintiffs only the sums due, if any, to the acts of the guardians. He

would make a note of Mr. Harrison's objections. Witness, proceeding, said his own salary as manager was £350 a year, and Brooks's average profits for the three years preceding 1893, as shown by balance sheets made out before the contract stopped (now produced), was £1,250 a year. Cross-examined: The particulars in the "heads of damages" were rough calculations made since July last, and the figures now given were detailed estimates made during the past week. He adhered to all the evidence given at the previous trial. He was closely pressed as to the ground plans submitted, with a view to show that they were inaccurate as to the basements of the old work, and also to show that another and more convenient entrance could have been used: but he adhered to the statements already made. Witness was further cross-examined at great length as to the prices of materials and wages paid, and produced his books and receipts. Some of the profits shown on balance-sheets were found on completion of works begun in previous years, and in the same way other expected profits on works in progress were carried forward. John Thomas Chappell, a contractor for 35 years, now out of business, said he had carried out many large works, including Cane Hill Asylum and Manchester Asylum (each £210,000), Camberwell Workhouse, General Post Office £140,000, Baron Grant's mansion £80,000, and Colonel North's house at Eltham over £80,000. Witness had examined St. Pancras Workhouse, and had inspected the contracts and the plans and specifications. The difficulty in getting possession of site and entrances on convenient levels would disorganise the whole business, and materially affect the opportunity of making a profit. Witness described in detail the order in which he should have carried out the works, provided the site was placed at his disposal uninterruptedly. The entrance provided was in a dangerous situation, and was the worst portion of the site. Again, the organisation of men, and turning them on from one block to another was everything in an extensive contract. If bricks were condemned for facings, but could be utilised for internal work, as alleged, it would obviously have been a convenience if there had been space on which to store, stack, and sort them. The learned judge remarked that many of the bricks were rejected from samples, and the bulk was not allowed to enter the works. Mr. Bray said that, according to the evidence already given, a greater number were passed over at the works, and were utilised for other work. Witness continuing, said there was sure to be some waste in handling such materials as bricks, due to want of space; but the major portion of the loss would be in labour, which was greater than would appear at first sight. In a work of this kind, costing £50,000 or more, where about £12,000 worth of work was to be done by independent contractors, over whom he had no control, he should have estimated the loss by delay and interference at not less than 5 per cent., and probably more. H. Holloway, of Battersea, said he had had twenty years' experience as a builder. He had inspected the St. Pancras workhouse, and also the plans and drawings, and considered the heads of damages. He agreed with the conclusions of the last witness. This witness was cross-examined by Mr. Moyses, but adhered to his estimates. H. H. Bartlett, sole partner in Messrs. Perry and Co., of Tredegar Works, Bow, a contractor of thirty years' experience, corroborated the evidence of the last two witnesses as to the increase demanded in cost and time that would be involved by difficulties in obtaining possession and interference deposited to by the first two witnesses. With slight modifications, he should have carried out the work as the witness Chappell proposed. The extra cost for delay and interference he should set down at from 8 to 10 per cent. over the whole amount on the actual cost. There was, in the middle part of 1893, a general rise in materials all round, but he could not estimate the amount, as with his experience, witness should have made provision beforehand—that was supposing storage ground existed on site. Of course, if they had to be delivered from other stores, the price would have been considerably increased. The charges for depreciation of plant and for supervision were perfectly fair, and for additional establishment charges for the fifteen months' delay from 5 to 7½ per cent. Cross-examined by Mr. Moyses: Witness carried out the first asylum built from Messrs. Harston's designs—that at Darenth—and had had considerable experience of this class of work. The sub-contractors ought to have been under the control of the contractors. In cases of interference, the architect was the person to smooth difficulties with sub-contractors over; but in witness's experience, complaints made to the architect produced very little effect. The learned judge asked how many more witnesses plaintiffs proposed to call. Mr. Bray: Eight or nine. The learned judge intimated that he did not propose to hear any further evidence of the same class from builders. Mr. Bray said in that case he would only call one other contractor, Brooks's predecessor on this job, William James Renshaw, manager and partner with Messrs. Kirk and Randall, of Woolwich, who carried out the first section

of the workhouse, and concurred with the previous witnesses. The prices in Brooks's bill of quantities were very fair indeed, and ought to have yielded a profit of about 10 per cent. under fair conditions. The cost of labour on the amount, guided by experience on the first part of the contract, ought not to have been more than from 42½ to 45 per cent., or about £17,000 on the £37,795, the actual cost of work carried out by Mr. Brooks. To that he added £1,000 for the rise on labour prices to September, 1893, and £2,000 for losses on work rejected, making £20,000 as the full amount, and if the actual cost of labour to Brooks was, according to the pay-sheets, £28,631, then the loss to Brooks due to interference and delay was £8,630, a very moderate estimate of the loss under these heads. At this stage the court adjourned until to-day (Friday).

#### WATER SUPPLY AND SANITARY MATTERS.

**BOMBAY.**—Extensive sanitary improvements are about to be undertaken in the city of Bombay, more especially in respect to the removal of insanitary dwellings and the prevention of overcrowding. The new scheme provides not only for opening up crowded localities, the construction of new streets with frontages for the erection of improved dwellings, and the levelling up of low-lying areas, but for improving existing dwellings and housing large numbers of the poorer classes in new buildings to be let at an extremely low rent. Vacant lands to the north of the city will be laid out, and, where necessary, filled in. Some areas west of Colaba are to be reclaimed, and will provide for residences of a superior class. It is proposed to create a special agency, with a separate staff, to devote their entire energies to the particular task before them. The entire cost will not be less than 3½ million pounds sterling, and may possibly amount to double that sum. The corporation still have to complete drainage scheme, control of civic finance, the water supply, the care of roads and streets, the public lighting, and many other duties.

**BO'NESS.**—The burgh commissioners of Bo'ness have accepted the offer of Mr. Thomas Peattie, contractor, to construct a large new reservoir on the estate of Lochcote, situated between Linlithgow and Bathgate. The contract amounts to £11,500. The reservoir will cover about 45 acres of ground and hold two hundred million gallons of water. The source of supply is the Wardlaw and Brunton burns, the waters of which will be impounded. The quality of the water is said to be excellent. The land which the commissioners purchased cost £7,000, and the laying of a main pipe from the site of the reservoir cost £3,615, and these sums, added to the cost of the reservoir, bring the total cost of the works up to nearly £25,000.

**CALCUTTA.**—A combined scheme for improving the outfall of the sewers of the town of Calcutta proper, for draining the suburbs and the area between the canal and the Circular-road, was commenced during 1897. Larger pumps are to be fixed at Palmer's Bridge, a high-level sewer is to be constructed which will meet a second high-level sewer intended for the suburban outfall, and the combined sewage of the town and suburbs is to be carried in a channel lined with masonry to a new outfall at Baintolla, some miles below the present outfall in the Balliaghata Canal. A main sewer is also to be constructed, which will enter from Watgunge on the Hooghly bank, and passing under Tolly's Nala by gravitation, will discharge at a station to be established near the Rifle Range on the Eastern Bengal State Railway. The suburban outfall will be precisely similar to one now working at Palmer's Bridge. There will be two pumping-stations for the suburban main sewer, one at the Budge-Budge-road and one at the outfall. The foundation-stone of the drainage works was laid by the Lieutenant-Governor, Sir Alexander Mackenzie, on the 26th November, 1896.

**DOUGLAS, ISLE OF MAN.**—A start in earnest was made on Friday with the new main sewer system adopted by the Douglas Town Council, after debates and opposition extending over years, the last opposition of a month ago having led to the withdrawal of the tender of a Glasgow firm for carrying out the land section of the work, at a cost of £26,000. The revised estimated cost, excluding any rise that may result from the withdrawal of the main tender, is £50,000. The section of the work now started is the new outfall, which will give a new discharge point for the sewer in the deep sea, about a quarter of a mile to the north-east of Conister, where there is nine hours' ebb-tide, which will carry the sewage clear of the bay. The present unsightly outfall is close to the landing pier. Messrs. Aird and Co., London, contractors, are carrying out this outfall section.—The Town Council considered on Tuesday the report of Messrs. Stevenson and Burstall, engineers, the authors of the improved scheme of drainage for Douglas adopted by the Council. Mr. Stevenson explained the causes that had resulted in his original estimate of £29,000

having been increased to over £49,000, and reported upon other matters connected with the scheme.—The Highways Committee recommended the Tynwald Court be applied to for further borrowing powers of £20,000, in addition to the £35,000 already sanctioned in connection with the scheme. Mr. Ciuca moved an amendment that Mr. Pritchard, who had also submitted a scheme to cost £29,000, should be approached in the matter.—The amendment was lost and the recommendation carried.

**PEWSEY, WILTSHIRE.**—In consequence of a recent outbreak of typhoid in the district, the parish council of Pewsey and rural district council instructed Messrs. Fairbank and Son, civil engineers, of York, to inspect the district and report as to the probable cost of a water supply. A voluminous report from them was presented to the Pewsey Rural District Council on Monday. They stated that an admirable supply of pure water could be obtained from Seven Springs, and carried through the district at an estimated cost of £3,469 10s., or £2,671 10s. if some isolated portions were left out of the scheme. The estimated annual expenditure would be £340, or £283 18s. for the partial scheme. These figures did not include land or wayleaves, and were based on the assumption that all the houses in the district would be connected with the system. It was decided to defer the consideration of the report for the present.

#### CHIPS.

Forest Fold Baptist Chapel near Crowborough was reopened last week after roofing and re-seating, and the addition of classrooms and vestries. Mr. A. E. Allen, of Northampton (late of Crowborough), was the architect.

The two-storied workshops of Mr. A. Taylor, a builder, in Lay-street, Ilford, suddenly collapsed on Friday evening. Elgar Chatterton, a carpenter, and a man named Burton were working on the top floor at the time. In the fall Chatterton was killed, but Burton escaped uninjured. The building walls, which consisted of 9in. brickwork, were only erected two months ago.

The vacancy for a clerk in the city surveyor's office at Winchester, on the promotion of Mr. Jennings, was filled up on Thursday in last week by the council of that city. A committee had weeded out three candidates from 71, and out of this trio Mr. Arthur Longland, for eight years in the office of Messrs. Cancellor and Hill, architects and surveyors, has been elected.

On Wednesday week two inquiries were held at the town hall, Tunstall, by Mr. H. P. Boulnois, an inspector of the Local Government Board, with reference to applications of the Tunstall Urban District Council for sanction to borrow £23,000 for purposes of sewerage and sewage disposal; and £5,000 for the purchase of land for the purpose of a public park.

The Sheffield City Council have decided to negotiate for the purchase of the Sheffield Electric Light and Power Company's undertaking on the terms of £220 of Sheffield Corporation Two-and-a-Half per Cent. redeemable stock for every £100 of the sum expended by the company upon their undertaking and chargeable to capital account, provided that the amount of such capital expenditure shall not in any event exceed £112,000, any further expenditure properly made being repaid to the company with 5 per cent. interest.

The want of an independent water supply at the Zoological Gardens has been felt for many years, and recently it was decided to put down an artesian bored tube well, the results of which have been the tapping of powerful springs of pure water in the chalk at the depth of 450ft., yielding 240,000 gallons per day. The engineers are Messrs. C. Isler and Co., of Southwark.

Subscriptions are being invited among the fellows of the Society of Antiquaries of London for the purpose of placing a memorial portrait in bronze of the late Sir Wollaston Franks, their former president, in the society's rooms, in recognition of his eminent services to archaeology. Mr. Charles J. Praetorius, who had for many years worked for Sir Wollaston at the British Museum, had various sketches and notes which, in his opinion, would enable him to produce a portrait, and, having modelled a life-size profile head in relief in wax, the work has been approved. The council will offer a duplicate copy of this for the acceptance of the trustees of the British Museum.

A deputation of the Worcester County Council held an inquiry at Hales Owen on Friday respecting an order directing that an isolation hospital should be established for the Stour-bridge Urban Council and Hales Owen Rural District Council, application having been made asking the County Council to make arrangements for the borrowing of a sum not exceeding £10,000, for erection of the hospital. The hospital will contain 30 beds, and the total, as estimated by the architect (Mr. Eyre, of London), is £9,150.

### Our Office Table.

THE inquest as to the cause of the great fire in Cripplegate was concluded on Wednesday at the Guildhall. The jury, after over four hours' deliberation, found that the fire originated on the first floor of premises in the occupation of Waller and Brown, Well-street; that it was caused by the wilful ignition of a stack of goods by some person or persons unknown; that there was no delay on the part of the Fire Brigade in arriving at the scene; that the appliances and steamers and supply of water were sufficient, but that the supply of coal to the steamers was inadequate; and that the causes of the rapid development of the fire were the style and construction of the buildings, the narrowness of the streets, the delay in summoning the Fire Brigade after the fire broke out, and the further delay of 14 minutes in getting the first engine to work. The jury offered various recommendations with respect to the reconstruction of the buildings and the improvement of the methods and appliances of the Fire Brigade. It was stated, in reply to the City solicitor, that the jury were not unanimous as to the finding that the fire had been wilfully caused.

THE First Commissioner of Works announced last year in Parliament that the Queen had approved of the Ranger's Lodge, adjoining Greenwich Park, being let by the Commissioners of Woods as part of the Crown lands under her charge, and that her Majesty would throw into the Park, for the use of the public, fifteen acres of land hitherto annexed to the Lodge. The Queen has now further decided that the old palace at Kew shall be opened as a public museum under the same management as Kew Gardens, and the grounds belonging to the Queen's Cottage will also be utilised in connection with the Royal Gardens at Kew. Furthermore, her Majesty has directed that the State-rooms at Kensington Palace, in the central part of the building, which have been closed and unoccupied since 1760, together with Sir Christopher Wren's banqueting-room attached to the palace, shall, after restoration, be opened to the public, and the Government will forthwith submit to Parliament an estimate of the cost of restoration.

IN connection with the winter meeting for teachers conducted by the College of Preceptors, Sir Joshua Fitch gave a lecture on Friday on the National Gallery and its educational uses. As Mr. Ruskin had said, this gallery was now for the purposes of the general student the most important collection of paintings in Europe. Of all the notable art galleries of the Continent, he knew none so choice as our own, none which contained so few inferior pictures, none in which the student of art would find such characteristic examples of what was best in the great schools of painting, and none in which he could trace with more exactness the history of art. In the 1,500 pictures of the national collection, classified into schools, and ranged round 22 noble rooms, a rich store lay open to the visitor, whether his purpose was simply to trace the development of art, or to study the growth of religious ideas, to observe the various costumes of different nations, the comparative treatment of landscape and of the aspects of nature, or whether it was desired to find out in how many ways national and individual characteristics have been represented by the painter. The lecturer went on to illustrate how the various purposes indicated might best be followed out by calling attention to characteristic examples of different schools represented in the National Gallery.

THE corporation of Bootle have recently advertised asking local builders and contractors to send in tenders for the erection of a lodge at the Derby Park, from plans and specifications prepared in the borough engineer's office. The advertisement states that "persons tendering must submit their own schedule of quantities fully priced out, which must accompany the tender." The Liverpool Master Builders' Association have written to the town clerk of Bootle, pointing out the unfairness of this condition, and that it will involve all but one of those who respond in a perfectly unnecessary and fruitless expense. So far, however, the association have not succeeded in obtaining the withdrawal of the objectionable clause.

FIVE years ago the City Council of Boston, Mass., appointed a board of appeal, to which disputes arising between architects, owners, or con-

tractors and the City Building Department are referred for settlement. The board is composed of an architect, a builder, and a lawyer. Nearly 200 cases have come before it for adjudication. The success which has attended its deliberations and conclusions can be judged by the fact that in only one or two instances have appeals been made to the courts from its findings.

THE vacant space in the decorative scheme of the ornamentation of the west front of the Doge's Palace in Venice has at last been filled up by a representation of the original statuary. This monument, which consisted of a figure of the Doge Gritti, together with a winged lion, was destroyed during the rioting which accompanied the fall of the Venetian Republic. Two years ago the Italian Government opened a competition among native artists and offered a prize for the best reproduction of the missing monument. The prize was won, and the work has been executed by a young Venetian sculptor, Urbano Bottasso. This colossal piece of alto-relievo sculpture, executed in Istrian marble, is about 11ft. long. It represents the Lion of St. Mark with his paw resting on the open Bible; opposite him kneels the Doge Gritti, draped in the ducal mantle and holding an inscribed banderole in his hand. The work was to have been completed by February, 1899, but such was the zeal of the young sculptor that the monument was finished more than a year before the stipulated time. The week before last the alto-relievo was raised to its place and fixed on the cornice over the balcony opening in which the Doges of old used to appear before the populace at special times and seasons. The inaugural ceremony has been postponed until March 22 next, when jubilee festivities will be held in order to celebrate the Revolution which gave freedom to Venice.

IT is proposed to hold in New York in the spring an International Health Exposition of a novel kind. Besides the display of heating and ventilating apparatus, plumbing appliances, model schoolrooms and hospitals, lectures are to be given on topics related to sanitation including pathological electricity, of which Mr. Nikola Tesla is to treat; and discussions will also be arranged. Mr. Charles F. Wingate, sanitary engineer, is the supervising director, and has contrived some striking illustrations of matters of hygiene, showing, for example, a county poor-house cell of the old type, with its "mad woman" chained to the floor, side by side with a modern asylum ward; and a schoolroom of the ancient pattern in contrast with one of the present model.

#### MEETINGS FOR THE ENSUING WEEK.

- MONDAY.—Royal Institute of British Architects. Business and Ordinary Meeting. 8 p.m.
- TUESDAY.—Society of Arts. "My Recent Journey from the Nile to the Soudan," by Frederic Villiers. 4.30 p.m.
- WEDNESDAY.—Society of Arts. "The Projection of Luminous Objects in Space," by Eric S. Bruce, M.A. 8 p.m.
- THURSDAY.—Society of Arts. "Recreations of an Indian Official," by the Right Hon. Sir M. E. Grant-Duff, G.C.I.E. 4.30 p.m.
- Society of Architects. St. James's Hall, Piccadilly, W. 8 p.m.
- FRIDAY.—Architectural Association Lyric Club. Concert at Swallow-street Club, Piccadilly. 8 p.m.
- Birmingham Architectural Association. "Malta," by the Rev. W. K. R. Bedford. 6.45 p.m.

The salary of Mr. J. Wilding, surveyor to the Runcorn Urban District Council, has been raised from £180 to £200 per annum, and is to be further increased £10 per annum for two successive years.

The Coventry and Warwickshire Hospital was open to the general public for inspection on Friday, after renovation, refurbishing, &c., at a cost of nearly £1,500. The interior has been ventilated, painted, and decorated, repairs executed, several wards and rooms rearranged, and a large sum of money spent on furniture, bedsteads, and bedding. Messrs. Whiteman and Son were the painters and decorators.

At a special meeting of the Liverpool Select Vestry, held on Friday, a report of the committee appointed to consider the hospital accommodation for the sick and infirm inmates of the workhouse was submitted and approved. The proposed scheme contemplates the erection of a new building, competitive designs for which are to be asked from Mr. Edmund Kirby and Mr. E. Willink (Messrs. Willink and Thicknesse), both of Liverpool. To the architect whose plans are not selected an honorarium of fifty guineas will be paid by the vestry.

### LATEST PRICES.

IRON, &c.		Per ton.	Per ton.
Rolled-Iron Joists, Belgian.....	£5 15 0 to	£6 0 0	
Rolled-Steel Joists, English.....	6 0 0 "	6 10 0	
Wrought-Iron Girder Plates.....	5 15 0 "	6 10 0	
Bar Iron, good Stafs.....	7 0 0 "	8 0 0	
Do., Loomwork, Flat, Round, or Square.....	17 0 0 "	17 0 0	
Do., Welsh.....	5 15 0 "	5 17 6	
Boiler Plates, Iron—			
South Staffs.....	7 17 6 "	8 5 0	
Best Suedshill.....	10 0 0 "	10 10 0	
Angles 10s., Tees 20s. per ton extra.			
Builders' Hoop Iron, for bonding, &c., £6 15s. 0d. per ton.			
Builders' Hoop Iron, galvanised, £15 10s. 0d. per ton.			
Galvanised Corrugated Sheet Iron—			
No. 18 to 20.	No. 22 to 24.		
6ft. gauge to 8ft. long, inclusive	Per ton.	Per ton.	
Best ditto.....	£10 15 0	£11 0 0	
	11 5 0	11 10 0	
	Per ton.	Per ton.	
Cast-Iron Columns.....	£6 0 0 to	£8 10 0	
Cast-Iron Stanchions.....	6 0 0 "	8 10 0	
Cast-Iron Sash Weights.....	—	4 2 6	
Cast-Iron Socket Pipes—			
3in. diameter.....	5 10 0 "	5 15 0	
4in. to 6in.....	5 5 0 "	5 10 0	
7in. to 24in. (all sizes).....	4 15 0 "	5 5 0	
[Coated with composition, 2s. 6d. per ton extra; turned and bored joints, 5s. per ton extra.]			
Pig Iron—		Per ton.	
Cold Blast, Lilleshall.....	105s. to	110s.	
Hot Blast, ditto.....	57s. 6d. to	62s. 6d.	
Wrought-Iron Tubes—Discount off Standard Lists f.o.b.			
Gas-Tubes.....	75p.c. Fittings	77p.c.	
Water-Tubes.....	70	72½	
Steam-Tubes.....	62½	65	
Galvanised Gas-Tubes.....	60	62½	
Galvanised Water-Tubes.....	55	57½	
Galvanised Steam-Tubes.....	45	47½	
10cwt. casks. 5cwt. casks.			
Sheet Zinc, for roofing and working up.....	£22 0 0 to	£23 0 0	
Sheet Lead, 3lb. per sq. ft. super.....	14 12 6 "	15 12 6	
Pig Lead, in cwt. pigs.....	13 12 6 "	14 12 6	
Lead Shot, in 28lb. bags.....	17 19 0 "	18 10 0	
Copper Sheets, sheathing and rods.....	58 10 0 "	59 10 0	
Copper, British Cake and Ingots.....	50 10 0 "	51 10 0	
Tin, Straits.....	63 18 9 "	64 18 9	
Do., English Ingots.....	67 0 0 "	67 10 0	
Spelter, Silesian.....	17 7 6 "	18 7 6	
	Per ton.	Per ton.	
Cut Clasp Nails, 3in. to 6in.....	£8 15 0	£9 15 0	
Cut Floor Brads.....	8 10 0 "	9 10 0	
Wire Nails (Points de Paris)—			
0 to 7 8 9 10 11 12 13 14 15	B.W.G.		
8/6 9/0 9/6 10/3 11/0 12/0 13/0 14/9 16/9	per cwt.		

#### TIMBER.

Teak, Burmah.....per load	£14 0 0 to	£15 10 0
" Bangkok.....	10 10 0 "	15 0 0
Quebec pine, pitch.....	—	—
" yellow.....	2 10 0 "	4 10 0
" Oak.....	5 5 0 "	6 5 0
" Birch.....	4 2 6 "	6 2 6
" Elm.....	4 0 0 "	5 0 0
" Ash.....	3 5 0 "	4 10 0
Dantsic and Memel Oak.....	2 2 6 "	3 2 6
Fir.....	1 16 0 "	4 0 0
Wainscot, Riga p. log.....	2 10 0 "	3 10 0
Lath, Dantsic, p.f.....	4 10 0 "	5 10 0
St. Petersburg.....	5 0 0 "	6 10 0
Greenheart.....	8 5 0 "	8 10 0
Box.....	4 0 0 "	15 0 0
Sequoia, U.S.A. ....per cube foot	0 1 8 "	0 1 10
Mahogany, Cuba, per super foot		
lin. thick.....	0 0 5 "	0 0 6½
" Honduras.....	0 0 5 "	0 0 6½
" Mexican.....	0 0 4 "	0 0 5
Cedar, Cuba.....	0 0 4 "	0 0 4½
" Honduras.....	0 0 3 "	0 0 4½
Satinwood.....	0 0 6 "	0 1 1
Walnut, Italian.....	0 0 3½ "	0 0 7
Deals, per St. Petersburg Standard, 120—12ft. by 1½in. by 1½in. —		
Quebec, Pine, 1st.....	£20 15 0 to	£26 15 0
" 2nd.....	15 5 0 "	17 15 0
" 3rd.....	7 15 0 "	11 5 0
Canada Spruce, 1st.....	10 15 0 "	12 5 0
" 2nd and 3rd.....	8 5 0 "	9 5 0
New Brunswick.....	7 15 0 "	8 5 0
Riga.....	6 15 0 "	7 15 0
St. Petersburg.....	8 15 0 "	12 15 0
Swedish.....	9 0 0 "	15 10 0
Finland.....	7 10 0 "	8 0 0
White Sea.....	9 0 0 "	16 0 0
Battens, all sorts.....	5 0 0 "	20 0 0
Flooring Boards, per square of lin.—		
1st prepared.....	£0 8 6 "	£0 15 6
2nd ditto.....	0 7 0 "	0 12 0
Other qualities.....	0 5 0 "	0 6 6
Staves, per standard M.—		
Quebec pipe.....	—	—
U.S. ditto.....	£35 0 0 "	£42 10 0
Memel, cr. pipe.....	230 0 0 "	240 0 0
Memel, brack.....	200 0 0 "	210 0 0

#### OILS.

Linseed.....per ton	£14 15 0 to	£15 0 0
Rapeseed, English pale.....	26 0 0 "	26 10 0
Do., brown.....	25 10 0 "	26 0 0
Cottonseed, refined.....	14 10 0 "	15 0 0
Olive, Spanish.....	32 0 0 "	33 0 0
Seal, pale.....	23 10 0 "	24 0 0
Cocconut, Cochin.....	26 0 0 "	27 0 0
Do., Ceylon.....	22 0 0 "	22 10 0
Palm, Lagos.....	22 10 0 "	23 0 0
Oleins.....	18 15 0 "	19 15 0
Lubricating U.S.....per gal.	0 6 3 "	0 7 6
Petroleum, refined.....	0 0 4½ "	0 0 4½
Tar, Stockholm.....per barrel	1 0 0 "	1 5 0
Do., Archangel.....	0 12 6 "	0 15 0
Turpentine, American... per ton	23 0 0 "	23 10 0

LIST OF COMPETITIONS OPEN.

Carlton, Victoria—Children's Hospital	£100, £50, £25	J. Nicholson, Hon. Sec., Pelham-street, Carlton, Australia	Jan. 30
Leicester—Motor Refuse Carts	Corporation	E. G. Mawbey, Borough Engineer, Leicester	31
Rugby—Public Work, Cattle Market		T. M. Wratislaw, Clerk, Rugby	Feb. 1
Eastleigh—Public Offices	50gs. (merged), 20gs.	Hy. White, Clerk, U.D.C., 19, St. Peter's-street, Winchester	7
Wolverhampton—Motor Vans	Public Works Committee.	J. W. Bradley, C.E., Borough Engineer, Town Hall, Wolverhampton	7
Barrow-in-Furness—Technical Schools	£50 (merged), £20	The Town Clerk, Town Hall, Barrow-in-Furness	14
Port Elizabeth—Free Library (Assessors, Sir F. Blaine and R. H. Hammersley-Hunan—£22,000 limit)	100 Guineas, 50 Guineas	G. Oettle, Librarian, Port Elizabeth, S.A.	15
New York—Sun Dial (Plaster Model)	500dol., 250dol.	Sec. National Sculpture Soc., 215, West 57th-street, New York	25
Newcastle-on-Tyne—New Infirmary (local Architects)	(No first) £150, £100, £50	Secretary Building Committee, Newcastle	Mar. 1
Berwick-on-Tweed—Police-Station (£5,000 limit)	Commission or £50, £25	R. Weddell, Town Clerk, Berwick-on-Tweed	14
Belper—Sewage Disposal Schemes	50 Guineas, 25 Guineas	Joseph Pym, Clerk, Belper	May 1

LIST OF TENDERS OPEN.

BUILDINGS.

Harwich—Additions to Schoolroom, Pulpit, Reseating, &c, at Congregational Church	Committee	J. W. Start, Architect, Colchester	Jan. 15
Pentre, Rhondda—Constitutional Club, Llewellyn-street		Edwin Jones, Architect, Porth, R.S.O.	15
Workington—Villas	M. N. Carlisle	W. G. Scott and Co., Architects, Workington	15
Archiestown—Alterations, Two Houses		D. Maclean, Blacksmith, Archiestown	15
Warmminster—Vagrant Wards	Board of Guardians	A. F. Long, M.S.A., Warmminster	15
Cette—Theatre (estimated cost, £10,583)		The Municipal Authorities, Cette, France	15
Filey—Fifteen Houses in Two Blocks	G. W. Tindall	J. Caleb Petch, Architect, Scarborough	15
Turriff—New Free Church Buildings		D. and J. R. McMillan, Architects, 211, Union-street, Aberdeen	17
Ireleth—Three Cottages	Late Margaret Newby's Trustees	R. P. Nelson, M.S.A., Surveyor, Broughton-in-Furness	17
Ryde, I.W.—Additions to Infirmary		J. Fardell, Hon. Sec., Market-street, Ryde	17
East Dereham—Town Hall	Trustees of the Headborough Estate	Chas. B. L. Norgate, Clerk to Headborough Trustees, E. Dereham	17
Elgin—Diamond Jubilee Cottages, Maisondieu		A. and W. Reid and Wittet, Architects, Elgin	17
West Auckland—Eight Houses	W. Riley and T. Spedding	F. H. Livesey, Architect, Market-place, Bishop Auckland	17
Crumlin—Creamery	Co-operative Dairy Society	Carlisle Arnold, Secretary, Lark-hill, Crumlin	17
Bradford—Two Houses, Mount-street	T. Browne	G. C. Gamble, Architect, Parkinson's Chambers, Bradford	17
Whitehaven—Alterations to Bee Hive	Dartford Rural District Council	J. S. Moffat, Architect, Whitehaven	17
Stone—Chapels and Caretaker's House at New Cemetery		J. C. Hayward, Clerk, Sessions House, Dartford	17
Brynmawr—County School	Amfield Plain Co-operative Society	John Thomas, Clerk, 194, King-street, Brynmawr	17
Medomsley—Converting Old Premises into Two Houses	J. Clements	G. T. Wilson, Architects, 121, Durham-road, Blackhill	17
Stanley—Theatre	Mrs. Hannah Chaytor	A. Ramsell, Architect, Dudley	17
Elgin—Distillery Warehouse		Edwin Bowman, Architect, 52, Westgate-road, Newcastle	18
Dover—Boiler-house at Sea Baths, Marine Parade	Town Council	Charles C. Doig, Architect, Elgin	18
Southill—Enlargement of Earlsheaton School	School Board	E. Wollaston Knocker, Town Clerk, Castle Hill House, Dover	18
Llanfair Caeirin—County Schools	Guardians of Hackney Union	Joseph Croft, Clerk, Market-place, Dewsbury	18
Homerton, N.E.—Alterations to Ward No. 23 at Union Infirmary		W. Story, Clerk to the Governors, Llanfair, Welshpool	19
Darwen—Eight Houses, Olive-lane	Corporation	Frank E. Coles, Clerk, Homerton, N.E.	19
Leeds—Bridge over Aire at South Accommodation-road		J. Latham, 55, London-terrace, Darwen	19
Bradford—Four Houses, Five Lane Ends	R. Goodhind	The City Engineer, Municipal Buildings, Leeds	19
Whitkirk—Villa		J. H. Dixon, Architect, 90, Heap-lane, Bradford	19
Huddersfield—Alterations and Additions to Shop Premises, New-street and Market-place		Chas. D. Swale, Architect, 98, Albion-street, Leeds	19
Bromsgrove—Goods Shed	Midland Railway Co.	John Kirk and Sons, Architects, Huddersfield	20
East Dulwich, S.E.—Repairs to Infirmary	Guardians of St. Saviour's Union	James Williams, Secretary, Derby	20
Shap—Restoration of St. Michael's Church		G. D. Stevenson, Architect, 13, King-street, Cheapside, E.C.	20
Glossop—Pavilion	Glossop Cricket Club	Geo. Dale Oliver, F.R.I.B.A., Carlisle	20
Blackwell—Goods Shed	Midland Railway Co.	R. G. Hawke, Architect, Bank Chambers, Glossop	20
Elgin—Dwelling-Houses, School Acre	School Board	James Williams, Secretary, Derby	20
Pembroke—Infants' School (for 400 children), Monkton	Directors of N. A. P. Bread Co.	Charles C. Doig, Architect, Elgin	20
Putney, S.W.—Bread Factory, &c.	Addison Swinglehurst	W. Cooper Harris, Clerk, Pembroke	21
Natland—Residence, Yew Tree Field	Managers	C. A. Giffin, Sec., 34, Victoria-street, Westminster, S.W.	21
Halifax—Extension of Atlas Boiler Works	East Sussex County Council	G. L. Hoggarth, Architect, 69, Highgate, Kendal	21
Wickham Market—Additions to Schools		Geo. Buckley and Son, Architect, Town Chambers, Halifax	22
Flushing, Cornwall—School Buildings		Henry J. Wright, 4, Museum-street, Ipswich	22
Boat of Garten—Villa		F. F. Savage, Flushing Vicarage	22
Guesting—Police Buildings		D. Macpherson, Boat of Garten	22
Lochmaben—Alterations to Free Church		Henry Card, County Surveyor, County Hall, Lewes	22
Cullingworth—Thirteen Houses		T. E. Watson, National Bank, Lochmaben	22
Epsom—Temporary Structures (for 700 patients and staff), Horton Manor Estate	London County Council	David Weatherhead, Architect, 55, Devonshire-street, Keighley	22
Bristol—Infant School, Hotwells	Bristol School Board	R. W. Partridge, Clerk Asylums Committee, 21, Whitehall-pl., S.W.	24
Chelmsford—Villas and Cottage, New London-road	Dr. Thresh	William Avery Adams, Clerk, Guildhall, Bristol	24
Swindon—Washing Baths	G.W.R. Medical Fund Society	George E. Clare, Architect, 66, Duke-street, Chelmsford	24
Llanwrst—School for Girls, and Alterations and Additions to Boys' Schools, at Llanwrst County School	Sanitary Committee	The Secretary, Swindon	24
Manchester—Thirty-two Two-Story Tenement Buildings, &c.	Commissioners of H.M. Works	Peter McIntyre, Clerk to the Governors, Llanwrst	25
Winchester—Enlargement of Post Office	Corporation	The City Surveyor, Town Hall, Manchester	25
Bootle—Lodge, Derby Park	Lancashire and Yorkshire Ry. Co.	Hon. Reginald B. Brett, Secretary, 12, Whitehall-place, S.W.	25
Hoghton—Passenger Station and Footbridge	Sanitary Committee	J. H. Farmer, Town Clerk, Bootle	25
Manchester—Thirteen Shops, Oldham-road		C. W. Bayley, Secretary, Hunt's Bank, Manchester	25
Burnley—Extension of Electric Light Station		The City Surveyor, Town Hall, Manchester	25
Manchester—Twenty-six Three-story Tenements and Two Shops, Pott-street, Ancoats	Sanitary Committee	G. H. Pickles, A.M.I.C.E., Town Hall, Burnley	25
Leeds—Dead Meat Market, New York-street	Markets Committee	The City Surveyor, Town Hall, Manchester	25
Bethnal Green, E.—Block of Dwellings on Boundary-st. Area	London County Council	Jno. Harrison, Town Clerk, Town Hall, Leeds	25
Manchester—Thirty-six Two-Story Tenement Buildings	Sanitary Committee	T. Bell, Clerk, Council Offices, Spring-gardens, S.W.	25
Milford—Gate Lodge and Entrance at Cemetery		The City Surveyor, Town Hall, Manchester	25
Manchester—Lodging-House, Harrison-street, Ancoats	Sanitary Committee	J. J. Phillips and Son, Architects, 61, Royal-avenue, Belfast	25
Hastings—Additions to Olive Vale School	School Board	The City Surveyor, Town Hall, Manchester	25
Bridlington Quay—Eleven Houses	Directors of the People's Palace	J. H. Tendall, Clerk, 4, Bank Buildings, Hastings	26
Mitcham—Visitors' Room and Engineer's House at Schools	Guardians of Holborn Union	W. S. Walker, Architect, Central Chambers, Bridlington Quay	26
Oven-den—Two Semi-Detached Villas	Guardians of Bromley Union	C. E. Vaughan, F.R.I.B.A., 25, Louthier Arcade, Strand, W.C.	26
Farnborough—Extension of Workhouse Infirmary	Guardians	Medley Hall, Architect, 29, Northgate, Halifax	26
Stockport—Workhouse, Stepping Hill	Billericay Rural District Council	R. Gordon Mullen, Clerk, 96, High-street, Bromley	27
Great Burstead—Repairs to White Bridge	Corporation	Charles F. Johnson, Clerk, Union Offices, Shaw Heath, Stockport	27
Wolverhampton—Shelter, East Park	London County Council	C. Edgar Lewis, Clerk, Brentwood	29
Tooting Common—Refreshment House	County School Managers	J. W. Bradley, Board Engineer, Wolverhampton	29
Tregaron—Intermediate School	School Board	T. Bell, Clerk, Council Offices, Spring-gardens, S.W.	31
East Ham—Schools (for 645 Children), White Horse-lane	London County Council	M. Morgan, Clerk, Tregaron	31
Camberwell—Refreshment House, Myatt's Fields	Corporation	W. J. Brett, Clerk, Lichfield-terrace, Upton Park, E.	31
Southampton—Isolation Hospital, Mousehole-lane, Millbrook	Rev. Thomas Taaffe, P.P.	T. Bell, Clerk, Council Offices, Spring-gardens, S.W.	31
Tullyallen—New Church	Governors of Grammar School	George B. Naider, Town Clerk, Municipal Offices, Southampton	Feb. 1
Dudley—Grammar School and Master's House, St. James's-rd.	Admiralty	William H. Byrne, M.R.I.A., Architect, 21, Suffolk-street, Dublin	1
Isle of Grain, Kent—Thirteen Coastguard Dwelling Houses	Urban District Council	Albert Morton, Clerk to the Governors, 15, Birmingham-rd., Dudley	1
Sandbach—Brick Tank at Pumping Station	Festiniog Board of Guardians	Director of Works Dept., Admiralty, Northumberland-avenue	1
Penthyneudraeth—Vagrant Wards at Workhouse	Guardians of Sunderland Union	W. Wyatt, Engineer, Bryndwr, Shrewsbury	3
Sunderland—Infirmary Buildings at Workhouse, Hylton-road.	St. Mary Islington Guardians	Thomas Roberts, Clerk, Portmadoc	4
Highgate Hill, N.—Infirmary (for 800 patients), &c.	Shaws, Bryant, and Co.	J. W. Hodgson, Clerk to Trustees, 17, John-street, Sunderland	9
Colchester—Business Premises, Long Wyre-street	Rev. Francis G. Jones, Vicar	Edwin Davey, Clerk, St. John's-road, Upper Holloway, N.	10
Edmonton, N.—Fifty Cottages	Bury Brewery Company	Chas. E. Butcher, Architect, 3, Queen-street, Colchester	
Stretford—Laundry, Chester-road	Brice, Butler, and Lee	Architect, care of Fuller and Jackson, 11, Grocer's Hall-court, E.C.	
Liandudno—Completion of Duke of Clarence Memorial Church		Johnstone Brothers, Architects, 33, Lowther-street, Carlisle	
Skegness—Two Boarding Houses		J. Oldrid Scott, Architect, 35, Spring-gardens, London, S.W.	
Bury—Five Dwelling Houses at Littlewood Cross		C. Nelson Holloway, Architect, Angel-row, Nottingham	
Nottingham—Workshop and Offices, Pepper-street		Thos. Nuttall, C.E., Architect, &c., 29, Market-street, Bury, Luacs.	
Oakworth—Warehouse, Providence Mills		C. Nelson Holloway, Architect, Angel-row, Nottingham	
Pontefract—Reconstruction of Inn		Judson and Moore, Architects, York Chambers, Keighley	
Padstow—Hotel		Tennant and Bagley, Architects, Pontefract	
		Crickmay and Sons, Architects, 13, Victoria-street, Westminster	



## THE BUILDING NEWS

AND ENGINEERING JOURNAL.

VOL. LXXIV.—No. 2246.

FRIDAY, JANUARY 21, 1898.

## THE FINISH OF BUILDINGS.

NO master mind has ever eschewed detail. Of all great masters of sculpture and composition in the plastic arts, Michael Angelo was probably supreme in grandeur of conception and power of grouping, and no one could accuse him of over-fondness for detail, and yet he has said "Trifles make perfection, and perfection is no trifle." We may expect to find exquisite beauty and finish in the work of a mosaicist, of an enameller, or a silversmith, but it is not thought to be one of the essential qualities in building. Yet nowhere else do we find the evidences of bad workmanship and design more destructive of all repose and comfort. Unless the architect devotes his attention to details, his work suffers from a want of completeness which often robs it of those essential qualities the public most look for. On such things as well-fitted doors and windows, fastenings, drains, and sanitary appliances, the client lays great stress; they are requirements which he thinks he has a right to expect as near perfection as it is possible. Less apparent and obvious to the ordinary owner or building client are those other minutiae of a design which place it above the production of the ordinary builder; but they are equally important if only the architect would give them the attention they deserve. To be exact in design, skilful in plan, to exhibit finesse in certain details, are qualities expected of the man who follows the profession of architect. It is not enough for him to design well, build substantially, to make his walls strong enough to bear weights and thrusts, to calculate the strength of floors and roofs: he must do more than all this if he aspires to the rank of master artist. In plan the effect of finish is important. We see it in such details as the treatment of corners, in the avoidance of sharp angles between two fronts of a building, in square-shaped rooms, in the position and arrangement of columns and pilasters, in dividing apartments, in the planning of halls and vestibules, the location of doors and windows, and in various other details. It is in these points we can at once distinguish the plan of a novice or simply practical man from that of a competent architect. With the former all is haphazard or rough;—the walls are divided at random, or there is no attempt to study plan architecturally; with the latter considerable thought is shown in aligning the walls, settling positions of piers and columns, and so arranging halls and corridors that they will contribute to the effect or the *tout ensemble* of the interior.

Those who have had experience in examining competition designs must have remarked these differences. They are like those which distinguish authors—that mark the studied and epigrammatic style of prose from the slovenly and loose composition. One sees at a glance whether the author has a grasp of his subject, or is merely setting down his ideas at random. And it is the difference between culture and ignorance, between thought and mere guesswork. To take, for example, the plans sent in for the Cardiff Town Hall and Law Courts. Compare the general distribution of the blocks, entrance hall, and corridors round the courts of the town-hall block in the premiated plan; the manner the assembly-hall is approached through a spacious ante-hall; the staircase

access, and the position of this hall and council-chamber on the first floor;—or take the central rates office under the assembly-hall, and its connection with the entrance-hall and lateral approaches, and then look at other arrangements. Architectural disposition and axial arrangement of blocks is even more marked in the second premiated design: the assembly-room and council chamber are *en suite* with a central reception-hall; the main staircase block is on the centre axis, and divides the two courtyards. The external angles are well broken and finished, and the corridors round the open courts have octagonal halls at the corners. As an example of architectural plan, this design holds a high place. The main rooms are balanced, and the various offices and town clerk's apartments are so grouped as to produce a well-broken exterior. How different to other plans where the chief offices are situated without reference to effect, and where an incoherent random disposition of parts are noticed!

In the interior of buildings, finish becomes a very important indication of the architect's study. The ordinary observer may not be able to distinguish between a building of the contract standard, and one that has been carefully worked out in detail; but he, nevertheless, feels the influence of skilful adaptation of plan—of well-appointed rooms and fittings, and of suitable decoration. The ordinary kind of business premises—say, a shop—is often rough and coarsely finished. The shop window internally is a compromise in which the engineer, joiner, and plasterer have each had a finger;—the walls are bare, the ceiling is intersected with cased beams, or coarse ill-designed capitals spread out on the flat plaster without any proper abacus or architrave. The partitions and fittings are of flimsy deal or mahogany framing, they go straight up to the ceiling without the slightest attempt at any finish or connection. One quality which distinguishes the work of the real artist from the incompetent is that of uniting agreeably; the crude, clumsy joint, the incoherent junction of two materials like wood and stone or plaster, or of two parts of a design, as the joining of a colonnade to the wall, or an arch upon its impost, are details which are sure to betray the architect. They are little matters—trifles which many overlook, but are really indicative of the master's hand. Even in the plainest and simplest building we can discern his care in little matters like springings of arches, impost mouldings, the details of jambs, &c., which the ordinary builder would overlook. In out-of-the-way corners, in dark passages and lobbies, in soaring vaults, his solicitude is never absent, as we observe in all old work, where the artist-craftsman had his heart in his work, and did what he thought was right, instead of what would save his own labour and his employer's pocket. So it has ever been, that the real architect thinks nothing too small for his attention; nothing escapes his care, even to the design of the moulding or the shape of a gas-bracket.

There are many things in our building interiors that are left to chance. The joinery or woodwork often offends by its very flimsy character. If it is a spandrel of a staircase, it is like thousands of others; if it is a cupboard or a door, it is one machine-made, suitable for any other building. It is specified as "so many super feet. of lin. or 1½ in. square framed or moulded," as the case may be, and this stereotyped description is sufficient in the eyes of the average architect, who looks mainly to cost, and regards all such fittings as mere builder's work. Why have we not done more in making our joinery and common framed work decorative by the use of hardwoods? In the better class of buildings in Canada plain pine is very little used for finishing; but maple,

birch, cherry, ash, and red oak are employed instead.

In the superior kind of houses and buildings these coloured woods give a finish and decorative value that cannot be obtained by ordinary pine. In Canada a house can be finished in red oak as cheaply as in pine, and the doors and framing, if veneered with it, on a pine or white cedar core, are very effective and durable. Birch and cherry are also used, plain, or stained to imitate mahogany; and the latter wood is straight-grained, and makes capital doors worked from the solid or cut into veneers. For flooring, Canadian hard maple has a good surface, and is said to be better than oak, and is closer in grain. Birch is also a good flooring material, and is used largely for stair-treads, and for newels and balusters. For superior joinery, the hard and coloured woods of America and Australia have a claim. Panels in one kind, and rails and stiles in another wood, give a finished effect, which cannot be secured by the use of ordinary deal as we import it from Canada or the Russian and Swedish ports.

But our modern joiner's work suffers mainly from the machine labour and the stereotyped forms with which it is put together. It is devoid of character and finish. The same sizes and dimensions occur, the same moulding is repeated *ad nauseam*. The modern interior is often very weak and incoherent in its mouldings. We notice repeatedly such crudities as pillars and supports cut off by a flat ceiling without any adequate capital, cased beams, or plaster mouldings running into corners at all angles, cornices dying away or losing themselves against a sloped surface like a stair soffit; framed wood partitions carried up to the ceiling without any cornice or moulding to connect the two surfaces. Or if a cornice or moulding is put round, it is made, perhaps, to cover the upper rail, which gives the appearance of the mouldings having been put up afterwards.

Then there is fitness or suitability of mouldings. To select any set of mouldings or members indifferently, without reference to the room or position, is a common fault in most interiors. We see cornices of coarse profile suitable for large rooms and halls put round small studies or boudoirs, or an insignificant series of beads round the ceiling of the entrance-hall. Badly-mitred mouldings, too, are always eyesores. The true artist will be careful in all these things, trifling though they seem. He will have neat and refined members round his door-panels and architraves, where they can be seen at close quarters. His cornices will be chosen to suit the character of the room and its height, a few delicately-cut members giving zest to one or two well-chosen curves; skirtings, surbase mouldings will be especially cared for, and the sash or casement frames and transoms will have sections chosen with particular reference to the play of light and shadow. Plasterwork design is often atrociously coarse or ill adapted, simply because the architect leaves the work to the contractor.

No less in the selection of details and fittings, the greatest care will be taken to avoid the coarse or bizarre. How many buildings are spoilt by ill-designed mantelpieces and grates, about which there is that "shoppy" look which savours of the show-room or the furniture dealer and ironmonger. Although some of these are neat and correct, they have that unmistakable character about them which shows that they have not been specially designed for the purpose. They may have been copied from designs of well-known architects; but they bear the imprint of unsuitability for their assigned position and surroundings. Looking over catalogues of designs for chimney-pieces, overmantels, overdoors, and cabinets, one comes upon "bits" by Norman Shaw, Col. Edis, and other well-known designers, torn away from their original context, and placed to adorn

very ordinary stock designs. When placed *in situ*, they lack those qualities of gradation and fitness that are intimately connected with the very nature of a finished building. There is a sense of coherence and continuity of design in all good architecture which can never be reached by a piecemeal way of doing things; and it is one of the elements which is remarkably absent in the average modern building of to-day, where all is done in pieces: a bit of Venice, or a bit of Bruges; a detail from here and a detail from there, or a sample from one manufacturer and a sample from another; all, perhaps, good in their way, but together unconnected and fragmentary. The ordinary ironmonger's fitting, too, is one (and not the smallest) detail which often destroys this quality of finish. It may be only a finger-plate or a door handle; but if it is too elaborate or too crude, it jars upon the sensitive eye. When will the architect begin to realise that the beauty of his design or building depends as much on finish and detail as it does on vigour of line and massing of parts?

#### THE SOANE AND OTHER PRIZE DRAWINGS AT THE INSTITUTE.

THE designs submitted for a Concert-Hall, the subject proposed for the Soane Medallion and £100, have failed to produce any response worthy of the problem, which required a little more skill and inventiveness in planning than the subjects usually chosen, and no prize has been awarded. The five designs submitted are commonplace enough. Not one of them has made the hall a feature; we have, indeed, the theatre type, in which the hall is made to represent an auditorium by a separate roof, and one of the authors gives us a Classic church or chapel-like exterior, with a central steeple over the entrance; but there is no effort to produce a design distinctive of a concert-hall open on two sides. "Pan" is shown by well-drawn plans of the several floors, stalls to seat 836 persons, area for 210, with entrance from ground level; balcony for 710, and first circle 725; and a gallery for 520 on third floor. The plan shows the hall of oblong shape, with circular end, and a stage contracted between curved walls of inverted form, like that of the Queen's Hall. The small room is placed along the front at end of large concert-room, and the side is occupied by the entrances and staircases, waiting-rooms, &c. A corridor goes round three sides of the hall. Staircases are provided at each corner, and the arrangement of entrances show some skill; but the author has lost sight of the opportunity. His elevations, in a style of Italian Renaissance, may represent a block of shops, and the curb roof over hall gives a heavy effect to the building, which has little that expresses the purpose.

"34° South" has a similar-shaped concert-hall with surrounding corridors. The front entrances look better arranged and more spacious. One feature in this design is a summer promenade on the flank side. The section also shows a more pleasing roof. Externally, a commonplace Classic treatment is adopted, with heavy centre frieze and attic, both adorned by sculptured relief. "Cornice" adopts also the same shape of concert-hall, the entrance and vestibule, and staircase arrangement are fairly good, and more space is allowed between the great hall and street front, and the small concert-room is also wider; but the author has mistaken our climate. His heavy and bare block of buildings, in an austere Florentine style, which represents auditorium, and the long block of buildings attached, are surely a satire on the conditions. "Lyra" departs from the rectangular-shaped concert-hall, and adopts a circular area, with a stage formed by a smaller ogival curve. The small hall

forms a block behind; and in front, toward<sup>s</sup> the street, which is somewhat triapsal in form, are the staircases in projecting wings, with vestibule, &c., between. The plan is ingenious, but not one that will lend itself to practical requirements. There are radiating boxes approached from ground-level round the hall. The author seats 3,000 in all, area, balcony, boxes, and gallery, and claims that the L.C.C. regulations are adopted. The design is Classic, the front entrances and rear building appear tacked on the huge circular drum of the auditorium. It has a flat domical roof, ribbed inside. "Quod erat Faciendum" is the motto of a design which represents a Classic church with tower in front. It is adorned by Corinthian columns. In plan the author adopts a plain rectangle, narrowed at the platform end by two main staircases. Two other staircases rise on each side of the main entrance vestibule. The plan is the strongest part of the design, simple and compact, with good angle staircases, a small hall in basement below the platform of large hall, with entrance from street level. The large-scale details are well drawn.

The Tite Prize subject is a design for a Villa and Ornamental Garden in England on the Italian style—a very good theme; but we cannot say that it has evoked much ability. There are nine designs. One of the simplest is "Andante"—a quietly-treated villa and garden shown by a clever bird's-eye view. There is a loggia and central hall with apartments round it. "Star" shows a too lofty villa: the centre staircase window is attenuated, and the building does not connect itself well with the garden. "Van der Neer" shows a triangular-shaped garden, but the design is commonplace. "Triangle in Circle" is wanting in breadth and dignity; the grounds are cut up into many shapes. A large ink perspective somewhat blurred is sent. "Lorenzo" shows a dignified conception of an Italian Villa, with wings and terrace arranged on the avenue side. The coloured view is well done. "Heather" is a palatial design, with the accompaniment of terraces and other adjuncts, but there is a want of breadth in the garden. "Orion," "Tiber," and "Italian Grandeur" are other designs which more or less miss the mark. The prize is awarded to J. Stevens Lee, and a medal of merit and 10 guineas is awarded to Thos. A. Pole.

A more appropriate exercise for candidates in design and construction has been afforded for the Grissell Gold Medal. "Design for a Small Country Church" of timber has brought out some ingenuity. One of the best designs, quietly and appropriately handled, is "Doan Tu Nomi." It is of stud-work and weather boarding, with cement rough-cast panels between aisle windows. The roof in one span continues without break from end to end, and there is a low tower with shingle spire at west end. The plan is simple, with a row of pillars along the inner side of passage aisles. In a more elaborate style is "Stave Kircke," in which the plan has transepts. Some good detail drawing is shown. "Emce" is original and clever as a piece of construction, though the design is more suitable for a preaching house than a church. A spacious square hall is roofed with diagonal principals, which are externally strutted or buttressed at the angles. The plan is too complex in its entrances. If the student's initials are "M. C.," or even "C. M.," the device selected is hardly a fair one, as it would give any member of the council interested in the competitor a clue to the authorship of the design. "T." shows cleverness in the drawing; but the external design is rather too much after the stone type. "Simplex" has a suitable treatment: the plan is simple, and there is a quiet picturesqueness about the west end louvred turret. Wooden buttresses are shown. "Thistle" is pretty and picturesque, as

shown by an artistic washed sketch of the west end; but the design is not suitable. "Tudor Rose" is too elaborate. The award is made to Mr. Harbottle Reed, and a medal of merit to Mr. W. Stanley Bates.

The drawings, on the whole, are creditable. The Pugin Studentship is represented by four designs by Jas. B. Fulton, Benj. Bower, Charles de Gruchy (who wins the studentship), and Ramsay Traquair. The drawings by the latter of York Minster, Skelton Church, New and Magdalen Colleges are careful, and sympathetically rendered. Benj. Bower's drawings and sketches of Wells Cathedral, the celebrated staircase to Chapter-house, and of St. Mary Magdalen, Newark, and the measured drawings of the Woolstaplers' House, Chipping Camden, are carefully executed, for which a medal of merit is awarded. C. de Gruchy sends several drawings of interest of a Chantry Tomb in St. Alban's Cathedral; St. Augustine's, Hedon; The Chevet, Church of St. Malo, Dinan; drawings of north aisle of choir, St. Mary, Beverley, &c. In the large meeting-room we notice some capital sketches by Travelling Students, 1897, of Lacock Abbey, S. Wroxall Manor—a clear sketch of porch taken from open casement of Montacute House, besides two effective drawings of a church roof and a screen. The coloured sketches of J. A. R. Inglis (Soane Medallist), the work of W. Haywood (Pugin student), A. E. Henderson, (Owen Jones student), are of interest. The Institute Silver Medal drawings and details, executed by "Clare," of Clare College, Cambridge, and the measured drawings of Charterhouse, by "Labor Omnia Vincit," and of Prior Crunden's Priory, Ely, by "Dum Spiro Spero" are meritorious. The prize is given to Thomas Tyrwhitt, and medal of merit to Cyril W. Smith. The Owen Jones Studentship has been contested by only two competitors, F. Lishman and R. S. Cockrill. Some very free and able sketches of the coloured tile panels in Lord Leighton's house. The "Arab Hall," and some elaborate coloured rood screens are exhibited.

#### ARCHITECTURAL ASSOCIATION.

THE sixth ordinary meeting of the Association was held on Friday evening, the President, Mr. Hampden W. Pratt, F.R.I.B.A., in the chair. Five nominations for membership having been read, Mr. T. G. Chambers was elected as a member. The President announced that the Elementary Water-Colour Class would start on Jan. 28, the instructor being Mr. Percy Buckman, and that Mr. Max Clarke would begin his lectures on "Ventilating, Lighting, and Heating," Division II., on January 31st.

#### COMPOSITION IN REGARD TO PUBLIC BUILDINGS.

MR. FRANK T. BAGGALLAY, F.R.I.B.A., past-president, read a paper on this subject, illustrated by numerous perspectives—both lithographs and photographs—of important edifices at home and abroad, showing the grouping and massing. He said he proposed to consider the principles that should govern the composing of the various parts of a building into a pleasing and harmonious whole. The composition of the completed buildings, Mr. Baggallay continued, is really the true function of the architect. In a properly organised system, the details and ornamentation would be left to the various trained craftsmen, who could, and would, be trusted to work in harmony with their chief and with each other. But ours is a disorganised system, under which no harmony can be attained unless the architect himself composes or (as we say) designs the details also, or has them efficiently copied from others which he can choose. The latter alternative has come to be universally condemned, and properly so. But the condemnation has been so noisy, and the attention it has attracted has been so great, that detail still continues to hold the absurdly prominent position it attained when all architecture was judged by the correctness with which the details were copied. In connection with any other matter, the admission that anything is a detail is sufficient to relegate it to at least the

second place in our consideration; but in connection with architecture it is often the only thing that is even noticed by the critic. Our only historian because, from the Renaissance up to his time architects generally borrowed a number of ornamental features and most of their detail from ancient buildings, proceeds to heap contempt upon all modern architecture as mere copyism, and goes so far as to tell us that true architecture "expired" at the Renaissance. Few and scarce have been the writers who gave a thought to such things as light and shade, grouping, proportion, scale, character and expression—except so far as the ornamental features were affected—who were able to lay aside the microscope and the dissecting knife and study the lines and pose of the model. The fact is, those critics of architecture who have succeeded in being heard have too often been men of literary and general, instead of architectural, culture, men to whom the ornamental part was the more obvious, and more easily understood. On the ornamental details their attention has been naturally fixed, and to such an extent that, for a time, they persuaded even architects that architecture was a matter of columns and cornices, or of window tracery and mouldings, or of something vague to be invented to take the place of these things. Mr. Fergusson himself was in no sense an architect, though a picture gallery is said to have been erected from his design, and he looked at architecture from the outside only, and, with all his careful comparison of photographs and book illustrations, never seems to have succeeded in seeing anything but a number of different systems of ornamentation which he could number and ticket and criticise for the astonishment of the public and the confusion of students. It is said that originally his aesthetic sensibilities were not deficient; but if that is so, he had certainly succeeded before he wrote his history of modern architecture in choking them with philosophy and burying them under a mountain of statistics. Yet even Mr. Fergusson might have avoided, if he had not been blinded by a complication of preconceived opinion and far-fetched theories, the gigantic mistake upon which he founded his indictment of modern architecture—the mistake of supposing that decorative features first began at the Renaissance to be imitated from older buildings. Had it been true, it would have been no proper foundation for a sweeping condemnation of modern architecture. But it is not true; it is so far from true that in every age there has been far more imitation than original design in architectural ornaments. The Egyptians, when they wanted columns and capitals and cornices for their temples, did not invent them, but copied in limestone and granite the bundles of reeds and the accidental forms of their earlier mud structures, and continued to copy them with but slight modifications to the end. The Doric temples were absurdly exact copies in marble of the more ancient wooden ones, even to the nail-heads. The details of the Ionic order were borrowed from Asia Minor, and some say the Corinthian also. The Hellenic Greeks, beyond adding a degree of finish due to their greater mechanical skill, never got very far from their originals. The Romans borrowed Greek details by the bunch, and in most cases without any alteration (except that they struck their curves instead of drawing them by hand), and applied them in their own way to their own uses, precisely as the Renaissance architects afterwards applied Roman details; and the Romanesque was but Roman work badly copied. The variations that were developed in the details of the Pointed styles of Western Europe in the three or four centuries through which they lasted were, it is true, considerable; but even they were developed very gradually, and under exceptional circumstances. It is very doubtful, too, if the successive changes were made consciously. Imitation is inevitable as regards architectural forms; and, moreover, it is the only road to improvement. It is not in the power of the greatest genius that ever lived to invent any great number of entirely original ones that will at the same time be acceptable. Those who have been least unsuccessful in the attempt have only succeeded in being absurd, while of the rest the less said the better. New forms must grow gradually, and will inevitably do so if we do not persist in harking back, or in trying to make fresh starts; and if we are not too vain to imitate where we cannot improve, nor too lazy to improve if we can. We need not copy; but we shall never get on at all if each man tries to invent a brand-new style of his own. On the other hand, neither

shall we get on if we condemn a fresh variation merely because it clashes with our preconceived notions. What we ask is—Is the change an improvement, or is its freshness its only justification? and if so, is the justification sufficient, or has something more important been lost in the shape of actual beauty or significance? In this matter a distinction may be drawn between details that are purely ornamental additions to the general composition, and those which have a functional character, either constructive or as emphasising any line or form in the composition; any change in these seems to demand some greater justification than its novelty. After all, the time and energy expended by architects in trying to freshen up the elements which go to make up their compositions seems as if it might be rather thrown away when we think that painters and sculptors have to use the same elements that their predecessors have been welding into works of art since the beginning of time. Should anyone ask, ironically or otherwise, how this heterodox theory is to be carried into practice, it must be confessed that the best of answers is very unlikely to be satisfactory. If these things could be done by rule, there would be no art in doing them, and they would cease to interest anyone. The most that can be done is to call attention to certain matters that seem to have led to success in particular instances, and therefore, presumably, may do so again.

#### THE THREE DIMENSIONS.

One of the first things to remember—and, considering the many temptations to forget it, perhaps the most important, however elementary—is that a building is not a flat thing, but an object of three dimensions, having depth as well as breadth and height; and that the best results cannot be obtained unless this is made obvious to the spectator. A comparison of the Church of the Salute at Venice with the Grimani Palace, or of Visconti's buildings of the Louvre with the Palace of Versailles, or of the Horse Guards building with Inigo Jones's Banqueting House, may indicate our meaning. All these buildings are supposed to be excellent works of art, although they come under Mr. Fergusson's description of "modern" architecture; but while the church in Venice, the Louvre in Paris, and the Horse Guards in London, look like complete buildings, the others, so far as appearances go, might be only ornamental walls. Two—the Salute and the Horse Guards—seem unsurpassed as examples of architectural modelling. The Louvre owes nothing to its details, which are, in fact, distressingly dreadful; but, like the other two, it shows its depth. It does so by means of the projecting arcade, and also (and more especially) by the roofs of the pavilions. The exhibition of the depth, or third dimension, by merely exposing the return wall, is useless. The two walls still appear to be merely walls, as may be seen by referring to the Banqueting House and Sir Gilbert Scott's Government Offices. What is wanted to suggest solidity is something showing over and beyond the walls;—in the Salute it is the dome, in the Louvre the pavilion roofs, and in the Horse Guards the charming little turret that Fergusson sneers at. Most Mediæval churches and public buildings—Continental ones, at any rate—depend mostly on their big roofs for the purpose, which they fulfilled in a simple, natural, and adequate manner; and most modern French buildings, and a few English ones, follow their lead. But here, in England, even in Mediæval times, notwithstanding there were the roofs, we liked to have also some solid structure rising from the middle of the composition, and advertising the solidity of the edifice by its substantial appearance. And we have continued to prefer the expedient, where we have adopted any at all, to an exhibition of the roof, possibly from an undeveloped feeling that all roofs look unsubstantial. At the Horse Guards, solidity is partly obtained by another expedient—more common because more easily applicable in many cases—namely, by pavilions rising a story higher than the rest, and so showing their depth; but it is the turret that pulls the whole together and makes one mass of it. In these days, large public buildings generally take the form of ranges of apartments surrounding one or more courtyards, and so far as the periphery of actual building is concerned, solidity is sometimes, though not often, given by higher pavilions. But it is now rare to find in England any attempt made to bring the whole together into one by a

great feature rising behind the external range. In a vast number of cases it might be done simply by placing the eternally recurring tower, that we put in the middle of our main front or stick on to a corner, within the courtyard, or at any rate well back from the outside walls. Of course, the tower, as a tower, would lose; at any rate, its aggressiveness would be suppressed; but that is just what is often wanted for the sake of the modelling and unity of the composition. Wherever the tower or other dominating feature of the composition is placed, its proportions, as seen from different points of view, might well receive more careful consideration than they often seem to get. If a tower is used, the main idea seems usually merely to run it up to an enormous height and give it, as nearly as possible, the proportions of a factory chimney. There is frequently the same tendency to excessive height in the drum of a dome, while the flat square domes or roofs used in France and Germany are generally too low. Both the mass and proportions of the main feature, whatever it is, should be regulated by those of the group to which it belongs; a low, straggling building wants a high and narrow tower; a more concentrated composition, something broader and lower in proportion. If the area or plan of the feature has to be small for the edifice, it must be carried up high, or it will appear mean; if the opposite is the case, it can only be subordinated to the whole by keeping it low; if it is made lofty it overwhelms the rest, which must then be itself treated as subordinate. To return to the question of the position of such a feature as a tower, balance requires that it should be somewhere near the centre of the composition. It is inevitably, and is meant to be, the chief object that attracts the eye, and if it is anywhere near the outside, still worse if it is at a corner, the group must be ill-balanced from most points of view. It is doubtful if the position should be the exact centre. The best painters and sculptors, though generally careful to put the chief point of interest near the middle of the composition and to preserve a general balance between the opposite sides, always avoid the formality of a strict symmetry. There is something, however, to be said for the view that architects may properly do otherwise, especially in public works; and that such buildings should be symmetrically designed, at any rate with reference to one main axis, the principal feature being upon that axis and not far from the centre of it. The formality which other artists avoid is really necessary to give that air of dignity and distinction to a great building which its character demands. It indicates organisation and order and balanced construction. If we pass in review a few of those works which, by common consent, are the greatest productions of our art, we find that it is easy to note and appreciate the simple majesty of the Parthenon, the spaciousness of the Pantheon, the soaring vastness of Sta. Sophia, the richness of St. Mark's, the airy splendours of the great Gothic cathedrals, and the exquisite lines of St. Paul's; but we cannot find any general arrangement common to all of them, except their symmetry with reference to a main axis, and are forced to the conclusion that though many varying systems may be productive of the grandest results in skilful hands, yet symmetry is necessary to all of them. On the other hand, it is noticeable that very few buildings of the first order are symmetrical with reference to more than one axis, and that there is a certain tameness when it goes beyond that; carried to excess, symmetry may easily take all the life and vigour out of a composition. For the sake of unity and concentration the main tower or other principal feature should be single, and not duplicated or further multiplied. If it is necessary to have more than one tower, for instance, or even broken-up roofs, still, some one thing should be large enough, and more especially high enough, to dominate the rest; and in such cases it is more than ever necessary to put it well in the middle. When seen in perspective,

#### THE ANGLES OF A BUILDING

are as much the ends of the group as they are in elevation, though not the same angles, and some feature, or, at any rate, different treatment, is necessary there to mark the definite termination and completion of the composition; without something of the kind a reason for stopping at that particular point seems to be wanting. In any extensive building, rectangular in plan, the sides of which recede from the spectator when seen in perspective, giving

long lines running away down towards the horizon, something more than a mere angle; pier or quoins will generally be wanted at the ends of the composition, or a little within them, to break such lines, and, as it were, lift them up. It is better for the general contour of the group if such features are not at, but within, the actual ends. They may even be the middle features of short fronts. The great thing is that they must break the lines; they must rise above the skyline, and their vertical lines ought to be higher than the cornice or finish of the walls generally, although the cornice may, and indeed should, as a rule, break round them. The necessity for carrying up the vertical lines of these features is often overlooked with unfortunate results, as in the case of the buildings of the Louvre before referred to. Great care should, however, be taken that these secondary features do not compete with the main central one for attention. They should be smaller in every way, but especially they should be lower; and to get the best result they should be entirely different in design. The hen-and-chickens arrangement of a great dome and several little domes, or a great tower or spire and smaller echoes of it, is always less satisfactory than a group in which there is no suspicion of an attempt on the part of the secondary features to ape the principal one. There should also be a very restricted limit to the number of these secondary features; neither the same design nor even the same general outline and proportions must be repeated too often; and never repeated in features which occupy different situations in the composition. Such repetition leads to both redundancy and the most poverty-stricken kind of monotony. In buildings like the Gothic cathedrals, in which the horizontal lines radiate from the centre, and consequently, when seen in perspective, run up instead of down, no secondary features to break them are required. A little turret or group of buttresses to stop the composition seems sufficient. It may appear a rather daring thing to say, but the western towers of cathedrals in most cases seem a mistake. They are generally far too large in scale, and too similar in form to the main central tower, to group well with it; and they are at one extremity of the composition, in most views balancing, if one can call it balancing, nothing at the other end; which, indeed, where there is an apse, is sloping downwards in a very undignified way. The Romanesque architect, in this respect, managed better, generally getting towers or turrets at both ends. Perhaps, where there is an unusually long nave, something smaller than towers, not placed at the extreme end, but a little way from it—say, another transept—would have been an advantage; but Salisbury has not anything, and, even apart from its size, it is a far more pleasing composition than Lichfield, with its three spires. Western towers, with nothing large enough over the crossing to hold its own, are a gigantic mistake, of which Cologne Cathedral is the typical example.

#### THE BREAKING UP OF SKY-LINES

is a thing that has often been recommended; but while it is generally necessary to break a long one upwards or stop it at the end, to break it by a drop or cut through it is a thing to be avoided at almost any cost, and to do so for choice is to make a very serious mistake. It is still worse to break through a main cornice. These lines are perhaps the most important in a composition. They are wanted to hold it together, and give it unity and strength, and to cut through them is like cutting the cords of a bundle of sticks, and allowing it to fall to pieces. After solidity and unity, one of the most important things to be seen to is character, and one of the chief elements in character is

#### SCALE.

Small parts tend to delicacy and pettiness, large ones to strength and grandeur. Small parts are supposed to make a building look large, and large parts to make it look small; but the influence of scale in that respect is probably greatly overrated; a man near, or any object the size of which is familiar, trees and surrounding buildings, and so on, give to the eye a just impression of scale which no exaggeration, in either direction, of the details of the building itself can do very much to remove. The attempt to give an impression of size by this means is supposed to be not only legitimate, but praiseworthy. But it is, after all, a species of deception, and one which really defeats its own ends; for there can be no object in trying to exaggerate the size of a building, unless

it be to produce an impression of grandeur; but small details necessarily suggest delicacy and thinness—qualities absolutely opposed to grandeur. If the smallness be more than is reasonable, or, rather, more than is customary, the structure even begins to look like the model of a larger one. It is, of course, possible to go too far, and to make details so large that they become coarse and vulgar. But for a public building, or any great architectural work, it is essential to its character that the parts shall be large enough to look exceptionally substantial, to suggest big piers, thick walls, a general massiveness, and, above all, largeness of idea and an avoidance of pettiness. Substantial construction may be suggested without the use of ornamental details by setting the door and window-frames back and showing deep reveals, by the use of large material, by plenty of unbroken wall, and in other ways; but the simplest treatment calls for a little detail of some sort, the scale of which will help to give character, and in public buildings should be large. Particularly the projection or relief should be adequate, since it is that which most suggests the existence of plenty of thickness. Thus attached columns, besides being more delicately shaded, and therefore more beautiful, are also a far finer treatment than pilasters. Unfortunately they are also more expensive and more difficult to deal with, but that is by the way. Whatever the scale is, it is most important to use it consistently. One used to be told that you must have two scales side by side, but that is a mistake; there is no harm in having a nave arcade of large arches and a wall or screen arcade of small ones, nor in using a large order on the walls and a small one for window dressing. What is inexcusable and destructive of harmony is to put a cornice consisting of a number of small mouldings on the top of a pier, the cap of which is composed of a few large ones, or to give the nave and screen arcades the same sized mouldings, or, to take a commoner case, put to the same building a block cornice composed of small mouldings and a plinth of one big one. This is a matter which is not infrequently overlooked in the sculpture and carved ornaments of a building, even when there is no fault to find with the architectural details. Sculpture, and what is called architectural carving, are generally used to emphasise certain points, or, as it were, to punctuate the composition; and to a certain extent also to cover up awkward lines or spaces, which by management of their own lines they can be made to correct or obliterate. But although these uses are legitimate enough, it is most effective in broad masses such as deep bands and friezes, and particularly in the half lights under cornices, pediments, and the like; perhaps because it breaks up and gives richness to the shadows. Attempts to deal definitely with the

#### LIGHT AND SHADE ON THE EXTERIOR OF A BUILDING

meet with little encouragement from the weather in our climate, where, during so much of the time, it is difficult to see the difference between the two, unless the shadow is a very black one; and an architect who depended on them alone would only get his effects for a few hours occasionally. It is, however, a very important subject, and always worth considering. The broader lights and shadows of the masses and breaks in a composition, of course, change in shape as the earth moves round the sun; but a consideration of the fine effect produced by a broad shadow might often influence the depth of a break if the designer thought about it; and if he remembered how beautifully a round surface curves and softens the edges of a shadow cast upon it, he might sometimes be influenced in favour of such a form. It is also true that a lighted surface may be thrown almost entirely into shadow by breaking up the surface, provided the aspect be favourable. But it is in the incidental shadows that most may be done. Incidental shadows arise from making recesses in lighted surfaces, or in contriving projections from them. Neither light nor shade, although they should be in broad masses, want to be in quite flat, unbroken ones. If there are a few windows or holes to give black spots, and a few projections—such as mouldings or balconies—in the lighted surface, and different depths of darkness in the shadow, both are richer and appear stronger. The finest broken shadows are those formed by a covered colonnade with a wall behind, giving delicately graduated shadows on the columns and

a deep one on the wall; such a feature also suggests solidity.

#### IN INTERIORS THE MANAGEMENT OF LIGHT

is one of the most important means of obtaining good effect. Instead of trying, as we too often do, to merely get an equal flood of light everywhere, that is precisely what we should try to avoid. While light enough is one thing, an all-pervading glare is quite another. A contrast of light and shade is as necessary inside as outside, and in this country we can do far more with it inside. A corridor equally lighted throughout its length is perfectly uninteresting, though the light be from the side or the top; but one which is crossed by a broad patch of light that increases the obscurity of the comparative shadow beyond is interesting at once. A definite light from one side or from above casts shadows and gives form to objects, whereas an equal light all round casts no shadows, and destroys form and distance. The worst light is one directly in the spectator's eye; not only is it physically annoying, but it shows everything in equal shadow. The best light is often said to be a top light, which throws all the upper part of the apartment into shade, and lights the floor and lower part of the walls. But light high up in the walls which lights the ceiling and leaves the lower parts in comparative shadow is even better. In internal effects generally we are at the present time, in our public buildings, immeasurably behind the architects of other ages, and even of our contemporaries in other countries. Any attempt, for instance, at a really fine staircase, or at a spacious hall, almost always frightens people if it is made. And it is seldom made because ninety-nine out of a hundred of our public buildings are the result of competitions in which architects are asked for an amount of accommodation which can only just be provided, if it can be provided at all, for the cost; and although it is sometimes stated that corridors and staircases are to be ample, every one knows that what would be considered the minimum in France would be regarded as sinful waste in England.

Mr. J. M. BRYDON proposed a vote of thanks to the lecturer for his suggestive treatment of a subject which ought to engage the attention of all young architects, for composition undoubtedly lay at the root of all architecture. While Mr. Baggallay had referred to the main features in composition which rendered a building great or the reverse, one or two points might well have been more emphasised. One of these was the influence of material on composition. Material had always exercised enormous influence on the forms and features of buildings. It was more easy to obtain largeness of mass and refinement of colour when using a noble material, such as marble, than when the designer was restricted to brick, or that latter-day abomination, terracotta. Immediately stone was substituted for wood in Greek temples the whole construction was ennobled, and assumed the character of masonry. He held strongly that architects must revert to the use of grand materials, such as stone or marble, for their public buildings, or they would fail in composition. It was nearly impossible to get a great building out of terracotta, which was not constructive, but merely decorative in character; if used at all, it should be employed as in the Science Schools at South Kensington, inclosed in broad masses of brickwork. Another effective example of its employment was the Great Hospital at Milan. Another important point in composition was the question of the site which the building was to occupy. An admirable instance of the utilisation of the brow of a steep hill was afforded by the Palais de Justice at Brussels, and the Church of the Saluté at Venice showed what could be done with a low, waterside position. He differed from the lecturer, and thought the lines of a tower should be brought to the ground; or, if not, should obviously grow out of the meeting lines of the building, as was the case with the grand dome of St. Paul's. Unless a building or tower had good proportion of parts, no amount of fussy detail would redeem it from being commonplace. In his condemnation of the hen-and-chickens treatment, Mr. Baggallay had happily emphasised the need for making some one feature dominant. Another common cause of failure in modern work was the want of reticence. He would say to young men, Do not put all your goods in the front window. If your building shows self-restraint, you may hereafter

be intrusted with a second commission. Inigo Jones was a master of proportion, and had a contempt for mere prettiness, as he said architecture should be solid, proportioned, masculine, and unaffected. One of the finest examples of architectural composition, and one which had not been referred to or illustrated, was begun by Inigo Jones and completed by Wren—he alluded to Greenwich Hospital.

Mr. H. H. STATHAM, in seconding the vote of thanks, said he was glad to hear the lecturer run a tilt at the notion that architecture was dead at the time of the Renaissance, for that dictum was a complete mistake. Although it took some details, the Renaissance did not borrow its design from the antique. It was rather amusing to hear Ferguson put through the mangle, although, so sure was he that everything he wrote was true, he would not have cared, had he been alive, to hear the attacks. Ferguson found too many best buildings in the world, and often flatly contradicted himself on successive pages; but Mr. Baggallay had done him some injustice in asserting that he gave his sole attention to detail. Ferguson, indeed, grasped the idea that the plan was the scheme of the whole building. Composition was the greatest test of a building; but it was also true that the refinement of the detail gave a means of judging of the attention a man had given to his art. With Mr. Brydon, he differed from the author in his views of the treatment of towers. He thought the tower should go down to the ground, and surely, where such a feature was placed at the angle of two streets, it ought to accentuate that angle. Mr. Baggallay had spoken very harshly of the details of modern French buildings, and they certainly lacked refinement, but he wished we could get sculpture of equal merit. The reason for the absence of a central feature to French and German cathedrals was the too great ambition of the designers; they carried the walls of these churches to such a height that they dare not add a central tower of sufficient dignity and scale. He did not think it was always well to carry a cornice all round a building. As for the iron and glass pavilion over the middle of the Parliament House at Berlin, he regarded it as the worst central feature on any modern building.

Mr. ARTHUR T. BOLTON said the meagre character of the pavilion just referred to was the fault not of the architect but of the committee, who insisted on reducing its height by 15ft. The Victoria and Clock Towers at the Westminster Palace were afterthoughts of Sir Charles Barry, and, as finally carried out, greatly improved the composition as a whole, although placed at the extremities of the site. The coarseness of modern French details was due partly to the character of the stone used, and partly to the fact that it was worked on the building. A central feature was absolutely essential for success in composition; some very fine buildings, including the Pitti Palace at Florence, had a very grand effect, although each consisting only of three horizontal masses, a central block, and two wings. Mr. Brydon had been hard on the effect of brickwork; but it was not always given a fair chance. The material was well employed in some Spanish palaces and Roman works. Brick should be used in broad masses, and the details from masonry should be transferred to this material. The Horse Guards building was designed by Kent; but the central turret was added after his death by Ripley, and this perhaps accounted for its crudeness of detail.

Mr. A. S. FLOWER thought in nearly all cases Mr. Baggallay had hit the nail on the head, and he agreed with him in thinking that in most cases the lower part of a tower could be smudged out of a composition with very good effect. Salisbury Cathedral was an eminently satisfactory example of grouping with a central tower and spire growing out of the intersection of the main lines, and, speaking for himself, he did not care for the treatment of the Victoria Tower at Westminster. Lincoln Cathedral was spoiled by the loss of its former central spire, which pulled the composition together. Most of the recent designs for towers shown in the building journals showed a preponderance of buttresses and a lack of a central dominant feature.

Mr. B. FLIGHT FLETCHER remarked that Burke, in his well-known "Essay on the Sublime and the Beautiful," put in an admirable way many points of composition in architecture. He would suggest that a class might, with much profit, be organised for studying this subject, which was now too often left by the designer to chance.

The PRESIDENT, in summing up, observed that site was undoubtedly the first consideration in tower architecture. He then put the vote of thanks, which was carried by acclamation.

Mr. BAGGALLAY, in acknowledging it, said he must confess to have overlooked the fact, brought out by Mr. Brydon, that material exercises a great influence on the general composition through its details. A tower, as a feature, would, of course, lose if put behind other buildings; but he adhered to the opinion that by adopting such a position the composition of the group as a whole would gain. He had not quoted Greenwich Hospital, as it ran contrary to his theory that a central feature was needed to give point to the scheme; it was a fine composition, but it took an Inigo Jones and a Christopher Wren to evolve so magnificent an exception to the rule. One of the failings of the present day was to think too much of the architect, and another was to judge of the success of a building by the refinement shown in the detail. He had exaggerated his case, he would admit; but he held greater refinement of detail could be obtained if the designer utilised old forms than if he aimed at employing original ones. If he chose his details thoughtfully, it would not matter if they were copied from old work. One of the difficulties in teaching composition in class was that there were almost as many exceptions as rules. He agreed with Mr. Brydon that one could not have a really grand building carried out in so small a material as brick.

ROYAL INSTITUTE OF BRITISH ARCHITECTS.

AWARDS OF PRIZES AND STUDENTSHIPS.

AT the close of the business meeting of the Institute held on Monday evening, Mr. Edward Gruning, vice-president, in the chair, the awards of prizes and studentships were awarded as follows:—

Essay Prize: Institute Silver Medal and 25 guineas. Subject of essay, "Review of English Architecture of the Nineteenth Century." Not awarded. One essay only submitted.

Measured Drawings: Institute Silver Medal and 10 guineas, Thomas Tyrwhitt, 36, St. George's-square, S.W.; Medal of merit, Cyril Wontner Smith, 34, Woodberry-grove, Finsbury Park, N. Six sets of drawings sent in, the subjects being "Ancient Buildings in the United Kingdom."

Some Medallion for design and £100 for Continental travel and study of ancient buildings abroad. Subject, a Concert Hall. Not awarded. Five designs sent in.

Pugin Travelling Studentship: Silver Medal and £40 for travel in Great Britain and Ireland and study of Mediaeval buildings. Studentship, Charles de Gruchy, 13, Melody-road, Wandsworth. Medal of merit, Benjamin Bower, 168, Vauxhall-road, Birmingham. Four sets of drawings.

Owen Jones Travelling Studentship and £50, for the study of ornament and colour decoration. Not awarded. Two sets of designs.

Tite Prize for Designs according to the Principles of Palladio, Vignola, Wren, or Chambers, and £30 for travel and study in Italy, John Stevens Lee, 78, Comeragh-road, West Kensington, W. Medal of merit and ten guineas, Thomas A. Pole, 35, Bernard-street, Russell-square, W.C. Nine designs submitted.

Grissell Gold Medal and Ten Guineas for design and construction. Subject, a Small Country Church. Harbottle Reed, 12, Castle-street, Exeter. Medal of merit, William Stanley Bates, 59, Clarence-road, Clapton, N.E. Twelve designs submitted.

Aldwinckle Studentship and £50 for travel and study in Spain, James B. Fulton, 34, Mecklenburgh-square, W.C.

Arthur Cates Prizes for testimonies of study prepared by students for the final examinations. June, Percy Morris, 67, Elliscombe-road, Old Charlton, Kent. November, Laurence Hobson, Hale-road, Liscard, Cheshire.

It was announced that at the meeting to be held on Monday next, the 24th inst., a criticism on the awards will be read by Mr. Ernest George, and an address to the students will be delivered by the president, Professor George Aitchison, R.A., who will also distribute the prizes.

THE WORK OF CHARLES KEENE.

[WITH ILLUSTRATIONS—SEE PAGE 92.]

MR. JOSEPH PENNELL, in writing the comments on the drawings of Charles Keene, which Mr. T. Fisher Unwin has reproduced in the "magnificent volume just published by him under the above title, unhesitatingly asserts that "Charles Keene is, with the possible exception of Hogarth, the greatest artist England has produced," and "that his work is uniformly

of supreme merit, that it is all worth the acquisition, the consideration, and the loving study of the collector, the writer, and the artist." Those who have combined forces in collating this exquisite collection of sketches and studies which constitute the value of the book thus produced, have unreservedly assisted in rendering possible so charming an addition to the national art treasures of the 19th century. There can be no doubt about that, though among the sincere admirers of Keene there are many who may scarcely be prepared to entirely endorse Mr. Pennell's eulogium above quoted. There can be indeed little gained, when treating on the work of so thorough a master of the pen and pencil as Charles Keene, by adopting such a superlative style of writing. This method of expression seems to have become chronic rather with Mr. Pennell. We willingly recognise, however, the aptness and sententiousness of his critical and descriptive remarks which accompany the specimens here so thoroughly well brought before us, and the introductory chapter which Mr. Pennell has indited with so graphic a touch and spirit, embodies much concerning Keene both new and *à propos*. That the artistic world did not adequately recognise Keene no one can call in question; but then all the chief socially important artistic societies in this country are overwhelmed with the influence of painters who seldom know or care for anything but oil- and water-colour painting, which, to them, is the limit of "Fine Art." Sculpture, architecture, black-and-white, as well as the applied arts, occupy but a very minor place in their ideal; and, moreover, it is of the highest consequence that the worker in any of these directions should pay tribute, above all things, to the shrine of cult and fashion. He must appear in public and pose; he should entertain and flatter the influential, taking the world, in fact, as he finds it. After all, too, there must be a recognition on both sides, and while we yield to no one in our admiration for the work of Charles Keene, it is but fair to acknowledge that side of his character which appears so evident in the pages of his "Life and Letters," by Mr. G. S. Layard—a book quite as appreciative of Charles Keene as that now before us. Keene accumulated a considerable amount of money, and his mode of life was not calculated to attract popularity excepting among the very few who knew him personally. We cannot, however, agree with Mr. Pennell when he says, "To the many, *Punch* meant Leech or Doyle or Du Maurier; only the few looked to it for Keene. The little that has been written about him proves the little that was thought of him. His drawings, as a rule, were received in silence or with a silly guffaw." We doubt the truth of this, and we think it very likely that Keene was far happier indulging in his eccentric isolation with his army of old clays, his curious collection of bagpipes, his economical solitude, cooking his own stews, and catering for himself, than he would ever have been as the lion of society, the member of any academy, or the hero of the hour. His work will live, and in that assurance, Keene must have found the greatest delight of his life, and to the capable worker in any art that, when all is said and done, remains the only aim for worthy ambition. Keene has left a legacy to the world, which will survive when most now so much in evidence has passed away; his wit was so human, his sense of humour so permanent, and his art of expression so real. Keene used to say that a man who could draw anything could draw everything. And we have only to turn over a collection of his drawings, such as those which we are enabled to enjoy in this admirably-produced volume, to realise how true this was of himself. Take his portraits, his studies of costumes or figures, his character sketches, the landscapes or bits from the sea-shore, his drawings of old buildings or notes of details. There is a sense of movement and expression in his figures, "he felt everything he drew," and possessed a delightfully humorous quality which was not fantastic—always kindly and genial, seldom whimsical, never vulgar, and always true to nature. The idea of the book which Mr. Fisher Unwin has issued was developed from the collection of original studies and preliminary sketches by Keene, which the publisher is fortunate enough to own, and so in the volume in many cases Mr. Pennell has been enabled to place the published illustrations side by side with the original designs. This is extremely interesting,

and to make the result more complete, the actual colour of the paper on which many of these preliminary studies were made has been reproduced in fac-simile. The photogravure of Keene's etching of an Old Timber House at Witley, where Keene had Tighbourne Cottage, rented of Birket Foster. "It is a very bosky-copsey country, very picturesque and English," he says. The plate forms the frontispiece, is one of the best things in the volume, and those which will probably attract our readers in a special way are the other architectural sketches, which deservedly hold a place of honour in the folio, for few who have only seen Keene's illustrations in *Punch* had any idea that he had such a love for old buildings. By the courtesy of Mr. Fisher Unwin, we print to-day three of these. The first represents Hever Castle, Kent, a study in ink on blue paper. The architecture is perfectly understood and expressed. Each line, too, in the foreground tells a story. The old church, also drawn in the original on blue paper, is unnamed. Possibly some of our readers may identify it. This would be an advantage. It might be in Kent. "Note the way" in which Keene "concentrates his blacks" (in this sketch), "and so gets brilliancy in the lights; the study he has given each pane in the windows, and the delightful trees in the distance." The third drawing is supposed to represent a piece of old Turnham Green. Another suggestion made is that it may be from Kew Green; but it is just possible the sketch was made at Hampton Court, facing the Common. It makes little difference. The drawing is excellent. It is drawn in ink on blue paper. Much value is added to this beautifully got-up work by the bibliography of the books Keene illustrated, and a catalogue of his etchings by Mr. W. H. Chesson. To those who have been associated in the production of this volume the task evidently has been a work of love.

#### "BUILDING NEWS" DESIGNING CLUB.

SMALL STABLE BUILDINGS FORMING LODGE  
GATE HOUSE.

THESE designs no not need much in the way of a description. The problem is unquestionably attractive, permitting of considerable picturesqueness of treatment, and the requirements are simple. Very few of the competitors, however, have risen to the ideal suggested, and none can claim (even if they wished to do so) to have realised a perfect scheme. "Byd" takes the first place, "Bantam" ranks second, and "Pantile" comes third. All three of these proposals are illustrated herewith, so that our judgment can be followed and, we think, confirmed.

To enable our readers to do this the more clearly we print as usual the conditions issued for competitors:—"Second List of Subjects.—(B) A small coachhouse and stable forming an entrance-way to the grounds of a country house, the coachman's dwelling being included and used as the lodge for this approach. The building is to stand on the frontage line of the property facing a high road. The accommodation is to provide for four stalls and two loose-boxes; a coachhouse for four traps or carriages, a harness-room, and washing covered space, and a loft for hay and corn. The entrance-way to be large enough to drive through. The dwelling to comprise a small parlour, good kitchen, 16ft. by 14ft., and larder, small scullery, and wood-shed; three bedrooms, one of which to be reached from loft, for use of groom. A man's w.c. besides that for use of lodge. No limit is placed on the site frontage, which is straight and level, facing N.W. The price will govern the undertaking, and £1,500 is the contemplated outlay. Style to be suited to a stone district, and roof covered with tiles. Picturesque simplicity and grouping is to be aimed at, and fussy, meaningless detail avoided. Scale, 8ft. to the inch. The plans may be 16ft. to the inch if desired. A perspective view of the front is essential, and sufficient elevations and sections to illustrate the design properly."

The elevation of "Byd's" design is very good. It suggests a connection with an important house beyond, and as belonging to a well-considered scheme. The abutment quasi-towers have a made-up kind of look about them; perhaps, though, in old gateways similar precedents could be found. The clock turret seems a trifle too big, and the bay windows are a little too low for healthy living-rooms and ample light. We

do not know what becomes of the man's room chimney: the turret absorbs it seemingly. The gatekeeper's lodge windows do not nicely command the gate, and the window of the front bedroom is omitted in the view. The gateway is large enough to drive through. With its faults well in view, we say this design is, on the whole, the most successful. "Bantam," the second man, gives us a good big gateway, and it has an air also of dignity; but similar faults to those already named in noticing the first design are also here evident. The perspective does not improve the look of the building, and the bell-turret, rising out of a lead flat, is not a great success. It cannot embrace the flue from the groom's bedroom fireplace. So short a chimney, if it ends at the parapet level, would want a smoke cowl. Fancy somebody's patent like a gargoyle on end at the corner! "Pantile," we presume, means to rough-cast his masonry; but in the view he omits even the joint-lines of the quoins, which in the elevations are somewhat important. The entrance arch is rather small for a coach and four. The design of the iron gates suggests a chancel enclosure screen. The grouping is distinctly pretty, but the affectation of the battered tower suggests the sand-and-card castle style of thing, which, if built, would in reality weather badly, and look ineffective. The cottage as a lodge is better than in the first and second plans, and there is no doubt in this case as to what becomes of the man's bedroom flue. The chimney, in fact, is so big that its support might well cause anxiety on looking at the plan. The arrangement of the stable is not good, particularly the loose-box.

"Gib" makes a rather strong fourth in this little contest, sending us a design in rather a French style, prettily relieved by red bands of brickwork in the upper part of the stone walls. His gateway is low as compared with the others, and the general appearance of the group somehow suggests the entry of a public institution rather than a gentleman's house. This, possibly, is due to the style. The plan is rather a good one, and the drawings are usefully and nicely done. "Petticoats" is the author of one of the best designs, and sends a crisply-drawn perspective; but, refined as some of his detail is, we scarcely think his archway with the oriel over can be counted as a success. The big, ungainly bell-turret helps to spoil the effect; but the bays are pleasing, and the plan is good, though there is no attempt at a stableyard, as there should be, to inclose the ostler's work from too great a prominence. Here it is all open to the main drive leading up to the mansion. "The Man in the Moon" avoids that objection, and gives us a design marked by merit, though a little commonplace. The look-out oriel window under the archway and the porch to the cottage are points showing thought, which we have not overlooked, and we observe that the planning is nicely contrived generally. The drawings, too, are neatly executed. "Go" shows a spirited endeavour to obtain picturesqueness of effect, which we are glad to welcome. He mars his views by introducing patches of black, regardless of the perspective of colour. The stable plan is not convenient with one loose-box round the corner next the main entrance, and the design is rather too ambitious and lacking in breadth. So capable a competitor ought to improve. "The Maggot" does not attempt the archway arrangement; but he plans cleverly and designs with taste, knowing the value of plain wall-space. The tower located in the corner of the stable-yard is not a success, and somewhat weakens the merit of a meritorious composition of which we have taken full consideration. "R. W. F." separates his lodge too much in idea from the rest of the block, and the road front of the stables is too much like a farm building, while the long, ugly, curved-shaped dormers are unsightly, and so is the clock turret with its curve-gabled hood. "Bernard" makes a good big archway under a broken pediment, and his façade would look suitable and dignified; but we do not like the plan, and the perspective is not equal to the occasion. It shows how meaningless the second turret really is. "Microbe" brings the visitor right into the stable-yard, quite losing sight of the fact that the archway is to form an approach to the house beyond. He draws neatly, and avoids vulgarity, but he is lacking in "go." "Turret" should leave out figures, unless he can draw them reasonably well. The three gables over his central building are rather pleasing, and his plan has distinct

merits. His gates of florid ironwork do not enhance the design, which is not particularly attractive. "Checkmate" makes a group of an ordinary lodge with stables at the rear, and an entrance gate with piers in the park wall. He does it suitably enough, but the real problem indicated by the instructions he has not undertaken. "Gossip" makes his archway too small, and leads us directly into the stable-yard. His elevation is well-designed and tastefully drawn with considerable care. "Stone" is too evidently inspired by a desire to make a small building assume the air of a big one, and the rear elevation is really better than the front. "Stone" draws neatly; but the elevation should have been drawn to  $\frac{1}{4}$ th scale. "Strax" gives a block roofed with pan-tiles, and designed like farm-buildings, and no doubt in execution they would look well enough; but the special application of the composition to our requirements is not so evident. We do not like the T-shaped stable, and a hospital box is best isolated from the other accommodation. "Hotspur," with a little more taste and some further degree of skill, could have made his scheme more successful, for its central idea is decidedly a good one, with the coat of arms carved within a shaped pediment over the archway which is situate in the middle of a long line of roof. As it is, the detail is very poor, and the drawings are indifferent. "Hotspur" must continue, and not grow cool in his ardour: he ought to improve. "Spark" gives us a block of stables and a house attached, but they might be anywhere. They would look fairly right; but if we passed them, there would be nothing to excite attention on re-passing, while the plan gives no suggestions. "Spark" needs inspiration. "Centaur" has spared no trouble, and we praise him warmly for thus doing his best. There is nothing to particularly avoid in his design; the stable front towards the yard is pretty, and he pleases us by his quiet simplicity, but a little more life another time would improve the author's chances of success. So good a worker ought to succeed. "Dach's" also has had a good try, though his attempt at originality looks better in elevation than in the view. The stable on plan is exceedingly cramped; the doors would nearly touch the horse's heels. Fancy a restive mare in stall No. 2; she would kick herself to pieces, and the stable-door too. "The Ant" marks his entrance by a square tower, and he knows the value of simple proportions. The object of the court to the rear is not so evident. "Derige" is a weak draughtsman, but his work suggests a tastefulness which we should like to see cultivated. The horizontal beam of the carriage gateway, and the timber-work over, and also in, the gables bespeaks an idea of good work, and so does the quaint little bay; but the whole thing is but indifferently worked out. "Hubert" is commonplace. "Solo's" design is a trifle better, but not so well drawn. "Sir Galahad" imitates a Jacobean gatehouse, with turrets flanking the gable, which is stepped. With this somewhat monumental aim, the strut-like bald buttresses alongside look very ill at ease. The remaining designs we have thus classified:—"Wun-Hi," "Joy," "Eric," "Phantom," "Nowhere," "Stanley," "Crow," "Vim," "Bull's-eye," "Klondyke," "Bonum," "Consilium," "Wen," "Spero," "Pick-me-Up," "Rosecomb," "Eldon," "Olliwops," "Wessex," "Orb," "The Bowery," "Kirby Hall," "Excelsior," "Inexperienced," "Mac," "Suburb," "Oak," "Spectator," "And Co.," "Chess," "Ravenna," "Cobden," "Don," and "Bow Bells."

A Local Government Board inquiry was held at Ramsbottom on Friday into an application for sanction to borrow £15,000 for sewage works, and £5,000 for street improvements. Already £32,000 has been borrowed. The inspector adversely criticised the council's action in proceeding with the sewage plan at Lower Summarseat without the board's sanction, and also referred to the heavy extras incurred on the original contracts.

Out-patients' buildings have just been added to the Medical College at Calcutta, and will be opened this month. Mr. W. Banks-Gwyther, A.R.I.B.A., is the architect, and the execution was superintended by Mr. B. K. Finnimore, Executive Engineer, 1st Calcutta Division, assisted by Mr. G. Trusler, who has been in immediate charge throughout. Externally the building is of red brick, with pale pink terracotta dressing and ornamentation from the potteries of Messrs. Burn and Co., at Raneeungee.

BUILDING NEWS DESIGNING CLUB.  
A LODGE & STABLES.  
Designed by PANTILE.

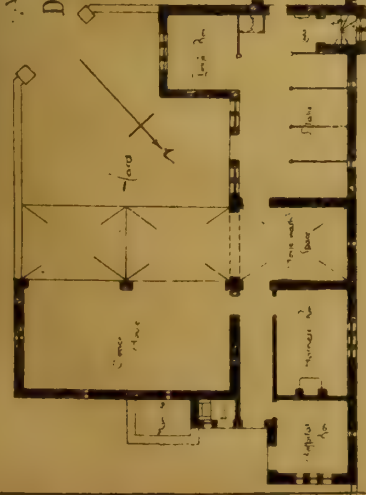

Ground plan

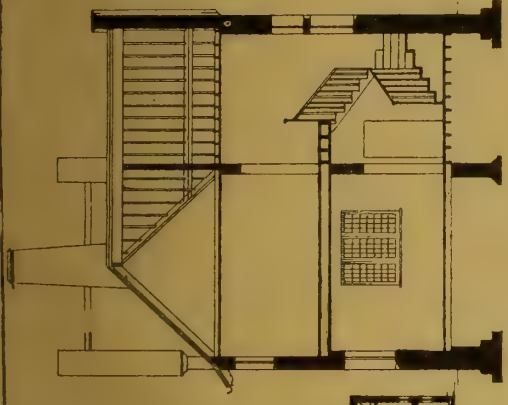

Section into Coachmans' Hall

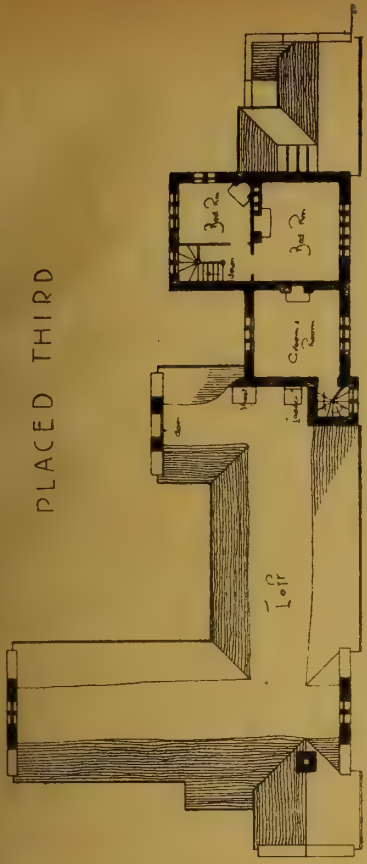

PLACED THIRD

First Floor Plan

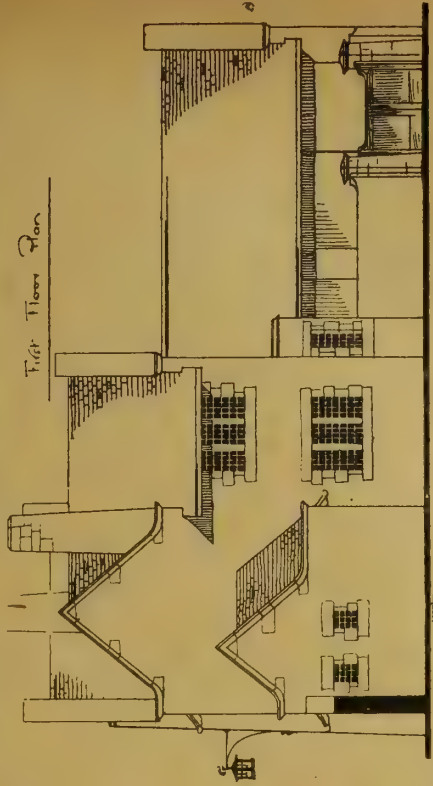

End Elevation

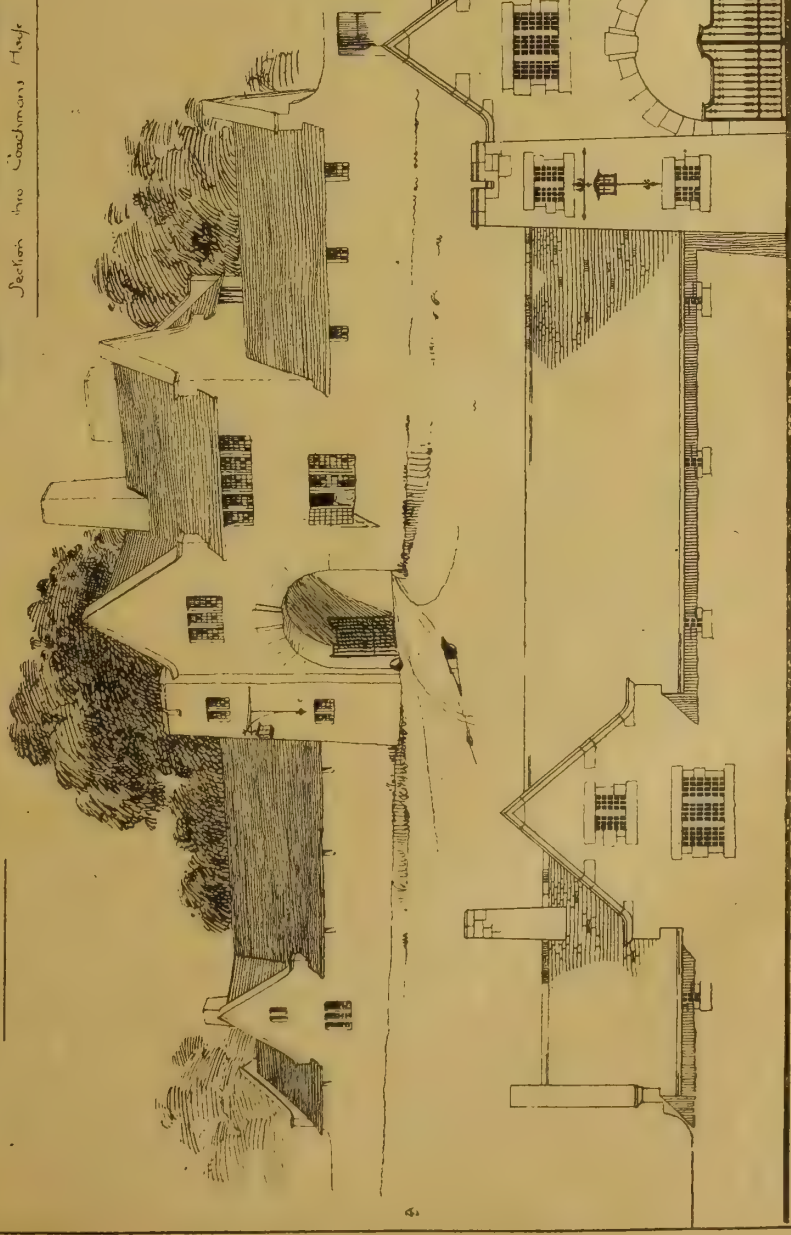

Main Elevation

Scale for Elevation

Scale for Plan

BUILDERS AND THE WORKMEN'S  
COMPENSATION ACT.

AN address on the provisions of the Compensation to Workmen for Injuries Act of 1897, which comes into operation on the 1st of July next, so far as they affect builders and contractors, was delivered by Mr. W. H. Brown, solicitor to the Bristol Master Builders' Association, before the members of that body on Monday night at the Guildhall, Bristol. Mr. August Krauss, President of the Association, occupied the chair, and there was a large attendance of members.

Mr. Brown said:—The perusal of the Act has brought very forcibly to my mind the fact that its conditions largely increase the liability of employers, so much so, indeed, as to make one regard the Act as the most sweeping and far-reaching statute for the benefit of workmen which has ever yet passed the Houses of Parliament. Before the passing of the Employers' Liability Act of 1880, an employer was liable at common law to his workmen under certain circumstances, because the master was bound to provide proper materials and appliances for his workmen, and was also bound to take other reasonable and proper precautions for the safety of his workmen; but this liability was practically a personal one, and unless there had been personal negligence on the part of the master, there was rarely, if ever, any liability attached to him. This common law liability has not been in any wise decreased by the passing of the Employers' Liability Act or the Workmen's Compensation Act. The operation of each of these Acts has been only to extend the liability and take away some of the employers' defences. The complaints against the efficiency of the Employers' Liability Act from a workman's point of view led up to the passing of the Workmen's Compensation Act, which was originally intended to come into operation on 1st January, 1898, but was then extended to March 31, and will now come into force on the 1st of July next. The extension of time has been made with the view of giving large employers an opportunity of making arrangements with their work-people, and of formulating a scheme of compensation to supersede the Act. As most of you are more or less familiar with the provisions of the Employers' Liability Act, I have thought it advisable to point out the main points of difference between that Act and the new one. These are:—(1) Pure misadventure or accident is no longer a defence. Formerly it was. (2) There is now liability in respect of the negligence of any person, whether in the employers' service or not. Formerly limited to negligence of foremen. (3) The workman's knowledge of a defect is no longer a defence. Formerly it was. (4) Contributory negligence can no longer be pleaded, except it amount to wilful and serious misconduct. Formerly it could. (5) The defence of common employment is completely gone. (6) There can be no contracting out except for equal or greater benefits. Formerly contracting out on any agreed basis was permissible. (7) There is now liability for subcontractors' men. Formerly there was none. (8) There is now a liability in respect of workmen engaged in manual labour or otherwise. Formerly the restriction was to persons engaged in manual labour. Then, as regards procedure, there is some slight difference with reference to notice and time for bringing the action, as the notice must be given as soon as practicable and the action commenced within six months, whilst with regard to actual proceedings, the whole county court work as it now stands is swept away and a scheme of arbitration substituted. Most of these points will come under notice if I take the Act section by section as briefly as may be. The first section of the Act deals with the liability of certain employers to workmen for injuries, and a later section defines what employment the Act refers to, and included in the list is "employment on, in, or about any building which exceeds 30ft. in height, and is either being constructed or repaired by means of a scaffolding or being demolished, or on which machinery driven by steam, water, or other mechanical power is being used for the purpose of the construction, repair, or demolition thereof." The scale of compensation is set out in the first schedule of the Act. A claim can only be made in respect of an accident arising out of and in the course of employment. This definition will probably give rise to a considerable amount of litigation before its exact meaning gets finally determined. If the accident arises

out of or in the course of the employment, it will not matter what circumstances led up to the accident, and it will be no defence for the employer that the accident was one which could not have been avoided, or even that it was brought about by someone who was altogether outside his employ; but in this latter case the employer can look to the person who caused the accident for indemnity, providing that person would have been legally liable to the workman, and the workman himself has the option of proceeding either against the master or against the outside person causing the accident. This liability of the master is an extremely wide one, and there are practically only three cases in which there is no liability on the master's part:—1. Where he can show that the employment is not within the Act. 2. Where if the employment is within the Act, the accident did not arise out of and in the course of the employment. 3. Where the person injured has been guilty of serious and wilful misconduct, to which misconduct the accident was attributable. After referring to the compensation provided by the schedule, he went on:—Sub-section B of Section 2 reserves to the workman any remedies he formerly had against his employer, but the workman must elect whether he will claim compensation under this Act or under his remedies prior to the Act coming into force. It will be seen that under this sub-section the employer is not to be liable to be proceeded against independently of this Act except in case of personal negligence or wilful act of himself or some person for whose act or default he is responsible; but having regard to the many cases which have dealt with the principles of the employer's liability at common law, it is probable that it will be found that the existing common law liability of the employer has not been very much affected by this sub-section. With regard to the limitation to the personal negligence or wilful act of some person for whose act or default the employer is responsible, this is a pretty plain reference to the employer's liability under the Act of 1880, where the employer is made liable under five distinct cases. In three of these cases the injury must arise from the negligence of the persons referred to, and it is believed the workman's remedy in those cases is left untouched, and although in one other case—namely, the first—the wording may at first lead one to doubt whether its effect has been altered, yet a careful consideration of the first of these cases leads me to the conclusion that the workmen will still have the option of proceeding under the Act of 1880 or under the new Act. With regard to the option reserved to the workman of proceeding either at common law or under the Employers' Liability Act, or to his representatives of proceeding under the Fatal Accident Act of 1846 instead of under the present Act, if an action is brought outside the present Act and upon the hearing it is decided that the employer is not liable in the action as brought, but that he would have been liable if such action had been brought under the present Act, then the court, if requested to by the plaintiff, must assess the compensation which would be payable to the plaintiff if the action had been brought under the present Act, but in determining such compensation the court may deduct the extra costs incurred by reason of the action having been wrongly brought in the first instance. It will thus be seen that the new Act, instead of taking away any of the old remedies which the workman had, has given him an entirely new one, and has given him the opportunity of proceeding in any way he pleases, with the certainty that if upon the hearing of the case it be found that he has made a mistake in electing to proceed under an Act which gave him no remedy, yet if he had a remedy under the present Act he will not have to take fresh proceedings, but will get an award at once. Sub-section C provides that the employer shall not be liable if the injury to a workman is attributable to the serious and wilful misconduct of that workman. It will probably be found that this will be a most difficult defence to establish, because the onus of proof is thrown upon the employer, and it will be necessary to show not only that the workman was guilty of serious or wilful misconduct, but that the injury was attributable to such misconduct. Section 3 of the Act provides that the whole question of compensation, whether as regards liability or as to the amount or duration of the compensation, shall be settled by arbitration. I have previously incidentally mentioned that there is no power to contract out of the Act except as pro-

vided by Section 3. This section provides that if a scheme is drawn up between the employer and his workpeople for the compensation, benefit, or insurance of the workpeople, and such scheme is on the whole not less favourable to the general body of workmen and their dependents than the provisions of this Act, then the Registrar of Friendly Societies can give a certificate, and until the certificate is revoked the employer can contract with any workpeople who assent to the scheme that they shall be subjected to the provisions of the scheme instead of the provisions of this Act. Such certificate may expire at the end of a limited period, not less than five years. No scheme can be certified which obliges the workman to assent to the scheme as a condition of obtaining employment. Under certain circumstances, if complaint is made to the registrar, and such complaint is shown to be well founded, the registrar can revoke the certificate, and shall do so unless the cause of complaint is removed. It will be seen that the widest discretion is given to the registrar in approving any scheme, and it will not be absolutely necessary that the scheme shall provide for greater compensation to be paid in case of accident, because other benefits may be given to the employed than those which are provided under the Act, and these may be held to be substantially greater than the benefits under the Act. Section 4.—This section makes the employers liable in respect of any work being executed by a sub-contractor. This is an extension of liability, as neither at common law nor under the Employers' Liability Act did it exist. Section 5.—This section gives the employed certain securities for compensation in case of bankruptcy. In the event of bankruptcy of an employer who is not insured the injured workman will come in as an ordinary creditor; but where the employer is insured against accidents the workpeople have the right to any moneys payable by the insurers, and this section provides how such moneys may be invested. Section 6 provides that where the injury for which compensation is payable was caused under circumstances creating a legal liability on some person other than the employer, the workman may proceed against such other person or the employer, but not against both. If the employer is proceeded against, he has the right to be indemnified by the other person. There will probably be considerable difficulty in the practical working of this section, because it will be very difficult to ascertain in some cases the amount required to indemnify the employer. Take, for instance, the case where weekly payments have to be made for a long term of years. The only other point to be considered is as to what is a building within the meaning of this Act. The building trade itself does not fall within the description of one of the employments mentioned in the Act, unless it is in respect of a building of over 30ft. in height, as before referred to. There does not appear to be any provision in the Act for determining how the height of the building is to be measured—whether it is to be from the front, or the back, or the side, or whether it would be sufficient if any part of the building is over 30ft. in height. The only known statutory definition of the height of a building, and how such height is to be ascertained, is in the London Building Act of 1894; and although this definition will certainly not be binding upon any arbitrator under the present Act, it may yet serve as a guide for any measurements under this Act. The framers of the Bill appear to have been anxious in this Act to prevent litigation so far as possible; but, as they had left it quite an open question as to how the height of a building is to be determined, there is little doubt that considerable litigation will ensue over this point before the correct mode of measurement is definitely ascertained. It will be noticed that, in addition to the building being required to be one of over 30ft. in height, it is also necessary either that scaffolding should be in use in the work, or else that the machinery mentioned in the schedule should be in use upon the building. This reservation as to scaffolding or machinery will not apply in the case of a building which is being demolished. You will, I think, have gathered that the present Act puts upon your shoulders as employers a very large additional liability, and one of so serious a nature that it will be a matter of grave consideration whether any employer of labour will elect to take the whole of the risk upon his own shoulders. It appears to me that the Act is likely to develop



insurance to a degree never before known. Of course, some of the very large employers of labour may prefer to be their own insurers, or they may have such a large number of workmen that it will be comparatively easy for them to frame some scheme for approval by the registrar in substitution of their liability under this Act; but for all except the very largest employers it would seem to be almost as much a necessity to insure against the liability created by this Act as it is for any owner of property to insure against fire—in fact, the arguments in favour of insurance are even stronger in the present case than they are in the case of fire, because if a man loses his property by fire he knows practically the extent of his loss, whilst under this Act his liability is by no means easily ascertained. The most serious point in the Act, in my opinion, is that, although in case of death there is a maximum compensation fixed, and that upon this point the employer can calculate his maximum liability, yet, in the case of total disablement, the liability to contribute towards the injured person extends for the remainder of the injured person's life, and it will, therefore, in most cases be found that not only is the loss to the employer far greater in case of disablement of workmen than in case of death, but that the difficulties of dealing with compensation for disablement cannot readily be overcome. It may well happen that an accident may occur which will disable two or three or five or more comparatively young workpeople, and the liability will then be created to pay them a certain sum of money for their lives. They may outlive their employer, and the gravest difficulty would arise in such a case in dealing with the estate of an employer saddled with such liabilities. It is quite true that the employer has the option after six months of getting an assessment of the sum to be paid by him in lieu of future payment; but in many cases the employer will probably hesitate to take this course, because the arbitrator will have considerable difficulty in fixing any such sum except upon an actuarial basis, and this would in many cases amount to a larger sum than the employer would be likely to desire to pay. I cannot help saying that I think it will be found that in the working out of the Act the absence of a limit to compensation will be found the most serious part of the Act with which the employers have to deal.

On the proposition of Mr. George Humphreys, seconded by Mr. George Wilkins, Mr. Brown was thanked for his address.

REFERENCE BOOKS ON ORNAMENT AND THE DECORATIVE ARTS.\*

I MUST ask you to carefully keep in mind the limitations imposed by my title, for I propose only to bring to your notice books which do not overlap in the treatment of their subjects, and please also remember that, as I am dealing with reference books only, my list must of necessity be brief. I intend classifying my subjects under the following heads:—In the first place, a few textbooks on the general principles of design and ornament, not referred to under special divisions. This list is short, and the titles are familiar. The smaller books on special subjects will be referred to in their places. Next the larger division—general reference books—and then books on special branches of the decorative arts. First, then, the smaller textbooks not mentioned under separate heads:—Jackson's "Lessons on Decorative Design" and "Theory and Practice of Design," Lewis F. Day's "Anatomy of Pattern," "Planning of Ornament," "Application of Ornament," and "Some Principles of Every Day Art," Ward's "Principles of Ornament," "Practical Designing" by various authors, edited by Gleason White, Professor Meyer's "Handbook of Ornament," Wornum's "Analysis of Ornament," Moody's "Lectures on Art," Ruskin's "Lectures on Art," Sir E. J. Poynter's "Lectures on Art," Aldam Heaton's "Beauty and Art," Collier's "Little Primer of Art," Redgrave on "Design," and Taylor's "Elementary Art Teaching." Of course, the library should possess a good selection of the invaluable series of handbooks issued in connection with the South Kensington Museum. They comprise short historical and illustrated accounts of almost all artistic industries, by eminent authorities on their subjects. I should also like to direct your notice to a similar and equally commendable series issued in France

under the title of "La Bibliothèque de l'Enseignement des Beaux-Arts." Some fifty of these manuals have been published at very modest prices, and among them are to be found works on many subjects outside the range of the South Kensington series. Most of the volumes in these two series of textbooks deal with special subjects, but after reference to them here I shall not particularise when I come to the subjects they touch upon, but leave you to find from the published lists which volumes are specially suitable to the wants of your readers.

GENERAL REFERENCE BOOKS.

First in a reference library should be found a good history of art, and that which comes first to one's mind is D'Agincourt's "History of Art by its Monuments from the 4th to the 16th Centuries," first published in Paris in 1823, translated by Owen Jones, and published in English in 1847. It illustrates 3,000 examples of architecture, sculpture, and painting, and the late Sir Matthew Digby Wyatt said of it some years since: "It is one of the attributes of this book that it can never fall out of date. It illustrates what must ever be the great wells from which artists will have to draw inspiration, and it is one amongst very few great works produced during the 19th century which is calculated to do more than minister to passing fashions in art." There have been one or two modern imitations of this book, but to my mind they fall very far short of its excellence and completeness. To those who desire smaller works I should recommend Lübke's "Histories of Art and of Sculpture," each in two vols. 8vo. For a full account of Eastern and Asiatic art we must turn to the volumes, produced in a handy form and brought down to date, by MM. Perrot and Chipiez, two energetic and able French archaeologists, of which works English editions have been produced, and form twelve volumes, 8vo. For a small and comprehensive work I propose Von Reber's "History of Ancient Art," an 8vo published in 1883. Mr. J. Ward, of the Macclesfield School of Art, has just published a manual on "Historic Ornament," which has illustrations selected from the works of Perrot and Chipiez, and other authorities. In a prominent position I must place that beautiful and invaluable book, Owen Jones's "Grammar of Ornament," which, first published in its original large folio form in 1856, served for more than a generation to enlighten our decorators and manufacturers in the principles and adaptability of design and colour, and it is now difficult to imagine how they and hosts of others managed before the existence of the epoch-making "Grammar of Ornament," which is now to be found in its original, or reduced and very inferior form, in most of the libraries, art schools, studios, or drawing offices of the world. But extraordinary as that publication was for its time, so much has since been learnt concerning Historic Ornament, so many delightful examples, more particularly of the Eastern and Renaissance styles, have been studied and drawn since its publication, and such improvements made in the art of chromolithography that I think it indispensable the two magnificent volumes by M. Racinet, issued under the title of "L'Ornement Polychrome," should be added to the library. In these volumes are 220 coloured plates, illustrating nearly 4,000 examples of ornament, not, with a few exceptions, found in Owen Jones's work. An English translation of the first series was published in 1877; but the second series, issued some eight years ago, has not been translated, and consequently is not so generally known in England as the first. To these works on coloured ornament I feel bound to add Owen Jones's "Examples of Chinese Ornament," a small folio volume which appeared in 1867. Its value, which cannot be realised from the title, consists in the varied examples it affords of the conventional treatment of flowers. The remarkable ingenuity shown by the Chinese in the treatment of floral forms in their application to decorative purposes renders the book invaluable to designers. I will here mention the extraordinary glossary of "Historic Costume," by M. Racinet. Its six volumes contain 500 plates, more than half of which are printed in colours, illustrating not only the costume, but house interiors, furniture, armour, and jewelry of all nations, and throughout all ages, so that it really forms a work of wider extent than is implied by its title. It is a most fascinating book to look over, and to show the careful manner in which it has been compiled, I may mention that the list of

authors from whom illustrations have been culled occupies some twenty-five pages. Various works have been published, each devoted to the ornament of an Oriental country; but these we cannot expect to find in a library of moderate compass, and the key to decoration in the various styles is contained in Owen Jones's and Racinet's works. The two reference books next on my list are French, the first being Viollet-le-Duc's "Dictionnaire du Mobilier Français," in six vols. 8vo, issued about 25 years ago. This, with the same author's "Dictionnaire de l'Architecture Française," is of world-wide repute. I think the following note by Mr. Russell Sturgis, a well-known American authority on Art subjects, worth quoting. Writing of the "Mobilier," he says: "This work is several dictionaries in one. The first volume is devoted to furniture, with, as appendix, some very interesting essays on the method of construction in the Middle Ages. The second volume deals with utensils in one alphabet, then with goldsmith's work, then with musical instruments, and then with sports and pastimes, including hunting and the tournament, and gives finally a few pages to tools of the carpenter, blacksmith, &c., a very curious encyclopædia of life in the Middle Ages. The third and fourth volumes are devoted to dress, the fifth and sixth to armour and weapons. The text is throughout of the most suggestive character, and generally trustworthy; the illustrations have that extraordinary value which belongs to the author's drawings." As you will see, the book deals most exhaustively with French Mediæval art; but, as a sequel, dealing mainly with art in the Renaissance period, should be added Harvard's "Dictionnaire de l'Ameublement et de la Décoration." Monsieur Havard devoted some fifteen years to the preparation of his work, which was issued between 1886 and 1890, and forms four volumes, 4to, having 250 plates, many printed in colours, and 2,500 smaller illustrations, including not only representations of furniture, but examples of the methods of producing it. The only small books in English which treat of the arts in anything like a comprehensive manner are Labarte's "Handbook of the Arts of the Middle Ages," and "The Decorative Arts of the Middle Ages," by Henry Shaw, both issued between 1850-60. I need hardly say that the beautiful works issued by this thorough antiquarian and art lover are worthy of all praise. I shall here include Augustus Pugin's "Glossary of Ecclesiastical Ornament and Costume," first issued in 1844, since it illustrates not only vestments, the ecclesiastical ornament of different countries, &c., but furniture, embroidery, and emblems as well; also J. H. Waring's "Arts Connected with Architecture in Central Italy," a folio issued in 1858, as the coloured illustrations are comprehensive, including examples of stained glass, fresco ornament, mosaic work, marble, and wood inlay. For a small dictionary we should have Mollet's "Dictionary of Terms Used in Art," an excellent little work compiled from various sources, issued in 1883. Amongst these reference books should certainly be found Gruner's "Specimens of Ornamental Art," selected from the best models of the Classic periods, as its eighty large folio plates give an unsurpassed series of Classic and Renaissance ornament drawn to a large scale. It was first printed in 1850, but is still unique on account of the scale of its drawings. Then I should like to mention a publication issued by an enthusiastic German antiquarian, Herr Hirth, and entitled "Der Formenschatz," also published under the French title of "L'Art Pratique." Since 1877 this gentleman has sent forth a yearly volume containing some 200 plates of photo-lithographic reproductions of work in every branch of ornamental design by the old masters of ornament in various Continental countries. These volumes are published at a very moderate price, and when we bear in mind the sum that a few of the original plates by any of these designers would cost, we must regard the collection as very remarkable and very valuable. The *Athenæum*, recently reviewing the last volume, speaks of the plates being a "perfect treasury of memoranda of all sorts." A sumptuous series of volumes has been published illustrating the marvellous collection of objects of art, formed by M. Spitzer, and dispersed a few years since. These, however, are so costly that they can only be contemplated for purchase by the richer libraries. A small folio catalogue illustrated by photographs is occasionally to be met with. I should like to draw your attention to a volume which is now to be met

\* Read before the Twentieth Annual Meeting of the Library Association, by Mr. HERBERT BATSFORD.

with at a moderate price, illustrating the art treasures of the exhibition held at Manchester in 1857. My reason for mentioning this is that the works illustrated are, with few exceptions, old examples, well printed in colours, accompanied by valuable essays on the different arts by such authorities as Owen Jones, Sir Matthew Digby Wyatt, Edmund Sharpe, &c. This volume, I believe, is often confounded with others illustrating modern examples in exhibitions, and is consequently overlooked.

(To be concluded.)

#### INFLUENCE OF SEA-WATER ON MORTARS.

**M.** E. CAUDLOT, in a recent paper, describes the action of sea-water on mortars, and his investigations in the harbour of La Rochelle since 1856 are of much value, as they extend over a period of 40 years. Blocks of 60 centimètres in length were exposed to the open sea from 1856 to 1875, and were above the water-surface at low tide. The mortars were of hydraulic limes of different origin, of natural cements from Pouilly, Vassy, &c.; of artificial pozzuolanas mixed with lime and sand; of trass from Andernach, &c. Nearly all blocks had completely lost their cohesion after different periods. The few blocks of Portland cement experimented upon were in good condition; but blocks of neat cement (English and French) were decomposed. From these tests Viennot draws the following conclusions: (1) Neat cements are destroyed more rapidly than mortars of a certain composition; (2) mortars made of one volume of cement to one of sand, and, again, of one volume of cement to two of sand, are those which offer the greatest resistance to sea-water. They will last for 20, 36, and 38 years.

Thurninger commenced new tests with blocks of masonry, and concrete made of lime and Speil mortar, with a length of edge of 40 centimètres. In 1895 the masonry blocks disappeared, their destruction having commenced four years after their exposure, and out of 32 concrete blocks only 26 remained, but they were in advancing decomposition. In 1880 other tests were commenced on blocks submerged, of various limes. Many of these have perished. "Out of 31 masonry blocks laid in Portland cement mortar, and submerged between 1881 and 1892, 23 are still intact, while some have commenced to disintegrate." Viennot points to the following conclusions: (1) Mortars of hydraulic lime, mixed in any proportion, in most cases commence to disintegrate after one or two years' immersion in sea-water; they crumble into pulp after periods varying in length, but apparently not exceeding 15 years. (2) Concrete resists better than masonry, owing to the greater density imparted to it by ramming. (3) Rapid-setting cements may commence to disintegrate after six or eight years, but may last longer than 38 years without crumbling. (4) The mortars offering the greatest resistance are those consisting of 1 part cement to 1 or 2 parts of sand. This mixture corresponds to the weight of cement required to fill the spaces between the grains of sand. These, therefore, are the least porous mortars.

#### A NEW BOOK ON OLD FURNITURE.

**M.** R. BATSFORD has just published a volume of examples of historic furniture\* which many of our readers will welcome, although the drawings have all appeared in our own pages; the sketches are reproduced to a larger scale and printed on plate paper in a rearranged form, accompanied by descriptive letter-press by the author of the drawings, Mr. A. Ernest Chancellor. The selection covers a wide range of subjects, more especially of English workmanship, including, not only typical examples of well-defined periods, but also unique specimens and uncommon varieties, which derive additional interest from some charm of singularity or freshness of idea. A very large number of the pieces was sketched at Christie's salerooms when famous collections of furniture changed hands, and others were drawn during the exhibition of loan collections in London during the past few years, so that by

\* Examples of Old Furniture: English and Foreign. Drawn and Described by ALFRED ERNEST CHANCELLOR. London: B. T. Batsford, 94, High Holborn 1898. 25s. net.

these means access was obtained to some of the most remarkable examples of old furniture extant. The book includes forty plates of about one hundred specimens, including a number from the Halls of the City companies. Some are measured and drawn to scale, and details of the manner of contriving internal arrangements or peculiarities of construction are furnished in other instances, while in most cases figured dimensions occur in the letterpress. The volume is handsomely produced, and makes a good book for reference for the cabinetmaker, architect, art collector, and decorative designer.

#### FOUNDATIONS ON CANTILEVER TRUSSES.

**A**N ingenious method of preparing foundations for small buildings for storage purposes is described in the *Engineering Record*. The system applies the cantilever principle to the support of the walls of a building 116ft. high, and has been devised by Mr. W. W. Crebore, A.M.A.Soc.C.E., and Frank Miller, C.E., of the Structural Engineering Company. The plan avoids all the difficulties and expense of constructing foundations on loose or uncertain ground like that of New York. The building described is 25ft. by 35ft., and is of the usual skeleton-cap construction. The structure is supported entirely by two rows of six columns each, each row being built in the thickness of the party wall. Cylindrical steel caissons, 5ft. diameter and  $\frac{1}{2}$ in. thick, from 12ft. to 16ft. long, were used; these encountered some difficulty in sinking in some parts till the rock was reached, which was inclined and irregular, and for this purpose sheet-pile or "lagging" had to be used; driven down to the rock on the deepest side. Sometimes the rock was stepped with benches. The caisson was filled with concrete, mixed wet, and rammed in footlayers. These caissons were ranged within the line of walls and clear of the footings, and the cantilever trusses enabled the side walls to be carried beyond the line of caissons. Their centres were 16ft. apart transversely, and also in a longitudinal direction. These trusses were riveted, having two chords and lacing pieces, and resembled in elevation two inverted triangles, connected top and bottom by the chords, 10ft. high. Thus, the spaces of the triangles rested on the bare stone of the caisson, and allowed the walls on each side to overhang nearly 4ft. 6in. in the line of the caissons or supports. All pairs of columns are thus supported on cantilever trusses, except the front pair, which are carried on twin plate girder cantilevers introduced on the front of the building. By the means here described, the walls of a building can be carried on supports placed some distance within the lines of the outer walls, and the whole weight of the superstructure of beams and columns is carried on twelve foundations or caissons that can be placed at any convenient distance apart.

Mr. Charles Wood has been promoted from the position of deputy manager to that of gas engineer to the Bradford Corporation, in succession to his father, deceased. The salary will be £600 a year, and the committee are about to advertise for a deputy manager at £250 a year.

It has been decided to adopt plans by Mr. J. O. Scott, for the restoration of the chancel of the parish church of Pipe-Ridware, Salop, at an estimated cost of £1,100.

Mr. Walter A. Ducat, one of the Local Government Board Inspectors, held an inquiry in the Guildhall, Canterbury, on Tuesday week, into the application of the city council to borrow £4,123 for the purchase of certain property in Guildhall and High streets, upon which they could either erect a new town-hall or extend the present building.

Mr. Isaac Wildash, for the past fourteen years surveyor to the Faversham Rural District Council, died last week from the injuries sustained by being thrown from his trap while engaged in his duties on the 8th inst. At the inquest held on Wednesday week a verdict of "Accidental Death" was returned; and at the meeting of the rural council, on the same day, a vote of condolence was passed to the widow and her family, and it was resolved to advertise for a successor at a salary of £200 a year. Mr. Wildash was 59 years of age.

The monthly report of the Labour Department for December states that in the building trades the percentage of unemployed union members was 2·8 at the end of 1897, compared with 2·1 for December, 1896. In the furnishing trades the percentage of union members out of work was 4·7, compared with 4·3 per cent. for December, 1896.

## Engineering Notes.

**PROPOSED THAMES LOCK AT WANDSWORTH.**—A conference of representatives of riparian authorities on the Thames between Isleworth and Fulham took place at the Hammersmith Town Hall on Friday, to consider a new report from Mr. E. Pritchard, C.E., of Birmingham, with regard to the construction of a lock on the Lower Thames. Mr. Pritchard had been requested to report with regard to a site at the foot of York-place, Battersea, midway between Wandsworth Bridge and the West London Extension railway-bridge. He reported that this site was much superior and more suitable than Broomhouse Dock<sup>h</sup> half a mile below Putney Bridge, the river being narrower, and that locks and sluices could be constructed there to hold up from six to eight feet of water above low-water springs, according to requirement, for £220,000. He advised the construction of half-tidal movable stone sluices, and a bridge to connect Battersea and Fulham with four central spans of 110ft. each. He also advised the construction of four locks upon the Middlesex side. The conference was well attended, a representative of the Wandsworth and Putney Board of Works, which had a rival scheme of its own at Broomhouse Dock, being present for the first time. It was unanimously agreed to recommend the scheme, with conditional approval, to the various constituent bodies for consideration.

#### ARCHITECTURAL & ARCHÆOLOGICAL SOCIETIES.

**DUBLIN MASTER BUILDERS' ASSOCIATION.**—The annual general meeting of the Dublin association was held at the Grosvenor Hotel, Westland-row, on Friday, the 14th inst., when the following officers were elected for the present year:—President, the Right Hon. Joseph M. Meade, P.C., LL.D.; committee, James Beckett, Richard D. Bolton, Thomas Conolly, Thomas Mackey, James Martin, James P. Pile, John Pemberton, Henry Sharpe, J.P., and Alderman Toole; James Kiernan, hon. treasurer; John Good, hon. sec. The report for the past year having been read and adopted, a resolution of condolence with the family of Mr. James Conolly, a much respected and prominent member of the association, was passed.

**GLASGOW ARCHITECTURAL ASSOCIATION.**—On Tuesday, the 11th inst., Mr. J. Kennedy Hunter, of Ayr, read a paper on "Some Points in Practice." The president, Mr. William Tait Conner, A.R.I.B.A., was in the chair. The lecturer spoke of the relations of the architect to the client, the contractor, and to his fellow architects. He favoured a fixed fee rather than a percentage, though an architect had no option but to grant a certificate to a contractor for work done, less the usual percentages; objected to architects' guarantees in competition, preferring an estimate by a skilled measurer; concluding by cautioning the members against accepting responsibility for the clerk of works, who was the client's servant. Mr. W. J. Anderson, A.R.I.B.A., opened the discussion. He hardly knew whether the client who did, or who did not, employ one was most troublesome. Mr. W. F. McGibbon, A.R.I.B.A., agreed that good architects deserved the standard percentage, but thought the fact that some got half or quarter of that was scandalous. Mr. John Fairweather, A.R.I.B.A., did not object to lump sum fees if they were big enough. The Chairman handed over the vote of thanks proposed, and referred to the gift of the Gildard Memorial Committee.

Mr. George Elkington, F.R.I.B.A., 95, Cannon-street, has been appointed to the surveyorship of the Coopers' Company, of which he has been a liveryman for 25 years. Mr. Thomas Barnes Williams, the retiring surveyor, has accepted a seat on the Court of Assistants.

Extensive improvements have been carried out at the Sittingbourne Waterworks, situated at Keycol Hill, two miles from the town. Powerful engines and pumping machinery have been introduced, and a new reservoir, capable of holding 300,000 gallons, and other buildings, have been erected, the whole work being executed at a total cost of £6,000. The finishing touch to the scheme was given on Saturday, when the members of the Sittingbourne Urban District Council paid an official visit to the works to inaugurate the electrical installation which has just been completed there.

CONTENTS.

The Finish of Buildings .....	81
The Soane and Other Prize Drawings at the Institute .....	82
Architectural Association .....	82
Royal Institute of British Architects .....	85
The Work of Charles Keene .....	85
BUILDING NEWS Designing Club .....	86
Builders and the Workmen's Compensation Act .....	86
Reference Books on Ornament and the Decorative Arts .....	89
Influence of Sea-Water on Mortars .....	90
A New Book on Old Furniture .....	90
Foundations on Cantilever Trusses .....	90
Engineering Notes .....	90
Architectural and Archaeological Societies .....	90
The Building News Directory .....	91
Our Illustrations .....	91
Competitions .....	91
Building Intelligence .....	110
Legal Intelligence .....	110
Water Supply and Sanitary Matters .....	110
Correspondence .....	111
Intercommunication .....	112
Our Office Table .....	112
Meetings for the Ensuing Week .....	113
Trade News .....	113
Latest Prices .....	113
List of Competitions Open .....	114
List of Tenders Open .....	114
Tenders .....	116

ILLUSTRATIONS.

THE NEW "ELEPHANT AND CASTLE" HOTEL.—"HERMIONE": ROYAL ACADEMY SILVER MEDAL CARTOON FOR A STATUE.—"SUMMERDALE," EPSOM, SURREY.—DESIGN BY MR. J. W. DUNFORD PLACED FIRST IN THE COMPETITION FOR WALTHAMSTOW PUBLIC BATHS.—DESIGNS FOR A GROUP OF STABLE BUILDINGS.—A SKETCH ON TURNHAM GREEN.—REVER CASTLE, KENT.—A VILLAGE CHURCH, FROM AN ORIGINAL DRAWING BY CHARLES KEENE.

Our Illustrations.

"ELEPHANT AND CASTLE" ESTATE.

This block of buildings is designed to cover the site of the present Elephant and Castle Hotel, together with the shops adjoining. The estate forms an island, which is well known, and is in a very conspicuous position, the headway facing the north, and having a frontage to Newington Butts and Walworth-road of about 80ft., and an average width of 34ft. will be occupied by the new hotel. The ground floor of the hotel is divided into saloon, luncheon, private and public bars, and the basement has a three-table billiard-room and cellarage accommodation. On the first floor are a double table billiard-room and large dining-room; on the second and third floor fourteen bedrooms and two large sitting-rooms, and on the top floor kitchen and domestic offices and four bedrooms. There is a separate staircase to domestic part. The other part of the site, which also has about an 80ft. frontage to Newington Butts and Walworth-road, and an average width of about 42ft., and return frontage to Short-street, consists of nine lock-up shops on the ground floor, with basements. The first floor is approached by a fireproof staircase from Newington Butts, and is designed for three suites of offices. The three upper floors have a fireproof staircase, approached from Walworth-road, and planned for eight separate suites of residential flats. The whole of the floors will be of fireproof construction, and the drainage and sanitary arrangements are to be carried out in the most modern manner, and the whole block lighted by electricity. All elevations are to be faced with cut and gauged red bricks and Portland stone dressings. All columns and piers to the ground floor will be granite, and the fascia and cornices to the hotel part will also be of granite. The dome and two smaller turrets will have copper roofs; the sign "Elephant and Castle" will also be gilded copper. Other portions of the roof will be covered with Westmoreland green slates. Mr. H. L. Holloway, of Deptford, is the builder, and the amount of his contract is £36,000. The architect is Mr. John Farrer, of 20, Finsbury-pavement, E.C.

"HERMIONE": ROYAL ACADEMY SILVER MEDAL DESIGN FOR A DRAPED FIGURE.

HERMIONE stands in a niche in the chapel, draped as a statue, and holding with one hand a black velvet pall. Marble-like and apparently lifeless, she awaits Paulina's word, which shall bid:—

Music, awake; strike! Time; and descend; be stone no more; approach; Strike all that look upon with marvel.

(Winter's Tale.)

—M. Y. TOWGOOD.

"SUMMERDALE," EPSOM.

THIS house occupies a beautifully timbered site in the Burgh Heath-road, and was erected for Mrs. M. Wood. It is faced with Bracknell red bricks, the upper portion being weather-tiled: the roof is tiled. All the internal joinery is of Oregon pine, stained and beeswaxed. The house was designed by Mr. J. Hatchard Smith, 41, Moorgate Station-buildings, London, E.C., Mr. J. A. Jeal, of Epsom, being the builder.

WALTHAMSTOW PUBLIC BATHS.

THIS design was placed first in this much-discussed competition by Mr. Rowland Plumbé, F.R.I.B.A. The site is situate in the High-street, and adjoins the Public Library, erected from my designs (BUILDING NEWS illustrations, September 23, 1894), and opened by Mr. J. Passmore Edwards. The accommodation provided is as follows:—Swimming-bath 128ft. by 35ft. (water area), 31 slipper baths, with waiting-rooms, superintendent's office and quarters, ticket office, club rooms, laundry, boiler-room, space for storage purposes, and other appurtenances. The estimated cost is £7,000, subject to 10 per cent. The decision of the assessor, who said that the building was "distinctly well designed and thought out, and appeared to have been designed with a view to being carried out for the estimated amount," was confirmed by the council who instituted the competition. This decision has been reversed by a new council, and the design placed second, entailing increased expenditure, adopted, under circumstances now being dealt with in your correspondence columns.

J. WILLIAMS DUNFORD.

"BUILDING NEWS" DESIGNING CLUB: A GROUP OF STABLE BUILDINGS.

(For description and further sketches see pages 86 and 87.)

CHIPS.

The Charing Cross, Euston, and Hampstead Railway Company have deputed a Bill for powers to extend their authorised line from a point under Charing Cross-road, near the Garrick Theatre, to a point under No. 23, Craven-street Strand. This extension is to be in substitution for the authorised Charing Cross terminus, which it is proposed to abandon.

Work was commenced on Tuesday on the extension of the Mashonaland Railway to Salisbury. Up to date some ninety miles of permanent way material has been shipped from England. The contractors, Messrs. Pauling and Co., are sending material forward from Beira at the rate of 100 to 200 tons daily. Sir Charles Metcalfe, the engineer, is now busy at Umtali arranging for the station at that place.

The tramways committee of Glasgow Corporation have recommended the acceptance of an offer from a foreign firm for the supply of tramway rails. The rails are required for relaying Springburn route, which is to be worked by the electric overhead-wire system, and for repairing other lines in the city. It is understood that the foreign offer is £1,700 lower than any other.

A new railway, affording communication between Plymouth and Yealmpton, was formally opened on Saturday. The line, which has been made by the Great Western Company, commences at Plymstock at the termination of the old Plymstock branch, and extends to Yealmpton, a distance of 6½ miles, the total distance from Plymouth to Yealmpton being 9½ miles. The line is single throughout, the ruling gradient being 1 in 60, and the sharpest curve having a radius of 15 chains. There are five stations—Billacombe, Elburton Cross, Brixton-road, Steer Point, and Yealmpton—all, with the exception of Elburton, having goods in addition to passenger accommodation. The railway has been constructed from plans by Mr. J. C. Inglis, chief engineer to the Great Western Company.

The extension of the town hall was considered by the town council of Newport, Mon., on Tuesday. The town hall now stands nearly in the centre of a block of business buildings bounded by Corn-street on the eastern side and by Austin Friars on the south-western side. At the rear on the latter side the present buildings of the town hall abut on Austin Friars and Dock-street. There is little more space to be obtained on that side, and finding that additional rooms and offices are needed, it has been determined to extend the town hall on the eastern side, in the direction of Corn-street. The premises, lately occupied by a grocer and stationer, have been secured at a cost of £20,305. The cost of removing present buildings and erecting the extensions will probably run into another £15,000 or £20,000.

COMPETITIONS.

BRISTOL.—A competition has been recently held in connection with the proposed Horfield Wesleyan chapel and schools, and at a meeting of the trustees, held on the 15th inst., the designs submitted by Messrs. La Trobe and Weston, 20, Clare-street, Bristol, were selected.

CARLISLE.—In the competition for a new board school in this city, Mr. E. R. Robson, F.S.A., of London, was appointed to advise the board, and on his report the first premium of £20 has been awarded to Mr. Rushworth, of Croydon (under motto "Red Circle"), and the second premium of £10 to Mr. Bottomley, of Middlesbrough (under motto "99"). Forty-five sets of plans were sent in, and the seven undermentioned were selected by Mr. Robson, and placed in order of merit as follows:—(1) "Red Circle," W. Rushworth, Croydon; (2) "99," J. M. Bottomley, Middlesbrough; (3) "Strength and Grace," H. P. Burke-Downing, Westminster; (4) "Holme," Stephen Piper, Newcastle-on-Tyne; (5) "Light and Air" (3), Hunter, Crawford, and Carfrae, Edinburgh; (6) "Knowledge," W. Y. Hobbiss, Southend-on-Sea; and (7) "Plan," S. Jackson, Fenchurch-street, London, E.C.

COLNE, LANC.—In the competition for a new board school, Mr. W. A. Royle, of Manchester, the assessor, has awarded the first premium of £20 to Mr. W. H. Atkinson, of Colne, and the second of £10 to Mr. John Varley, of the same town. The design of Mr. H. Holgate, also of Colne, was placed third, and it is stated that the last-named competitor has been appointed architect for the schools.

FYLDE UNION.—Sixteen sets of plans have been received in this competition for new work-house and offices, and the guardians have appointed a F.R.I.B.A. as assessor, who is now giving the matter his attention.

MORECAMBE.—At a special meeting of the urban district council, held on the 14th inst., the twelve competitive schemes for the sewerage of the district were again considered, and eventually one submitted by "Forward" was adopted. This scheme will serve for a population of 60,000, including Bare and Torrisholme. The estimated cost of the works is £39,227 10s. 9d. (exclusive of wayleaves, engineering, or land), with an estimated annual working expenditure of £620 2s. 6d. for a population of £45,000. To this must be added the cost of the "septic system," which was agreed to at the last meeting, and which will form a part of the scheme. The successful competitor is Mr. H. B. Nichol, C.E., of Birmingham. The cost of the schemes submitted varied from £19,000 to £66,000.

WESTBURY.—Mr. Edward Gabriel (Edmeston and Gabriel), the assessor appointed by the committee of the Westbury-on-Trym National Schools, Gloucestershire, in connection with the recent limited competition for new schools, has placed the design submitted by Mr. W. L. Bernard first, and that of Mr. Hy. Hirst second, in order of merit, and the selection has been confirmed by the committee.

The senate of Cambridge University on Saturday re-elected Mr. W. Ridgeway, M.A., of Gonville and Caius College, to the Disney Professorship of Archaeology.

The new parochial hall adjoining St. Matthew's Church, Bootle, was opened on Friday by Miss Ryle, daughter of the Bishop of Liverpool. The plans were drawn out originally by Mr. Charles Aldridge, F.R.I.B.A., who, however, did not live to see the work commenced. Its prosecution has been intrusted to his son, Mr. Ernest Aldridge, under the superintendence of Messrs. Willink and Thicknesse, of 14, Castle-street, Liverpool. The contractors for the whole work are Messrs. George Woods and Son. The cost has been £2,400.

The Court of Appeal in Dublin gave judgment on Friday in the case in which a syndicate of gentlemen sought to establish their right to inclose the Giants' Causeway, and deprive the public of free access to it. The syndicate alleged that they were entitled to exercise the right which they claimed under a lease which they had obtained from Mr. Hugh Lecky, the owner of the property within which the Causeway is situated. When the case came before the Vice-Chancellor he declared the plaintiffs entitled to the Causeway and the lands comprised in the lease. The Court of Appeal now confirmed the decision as regards the Causeway, but decided that the road leading to the Causeway was a public road, over which the public had a right of way.

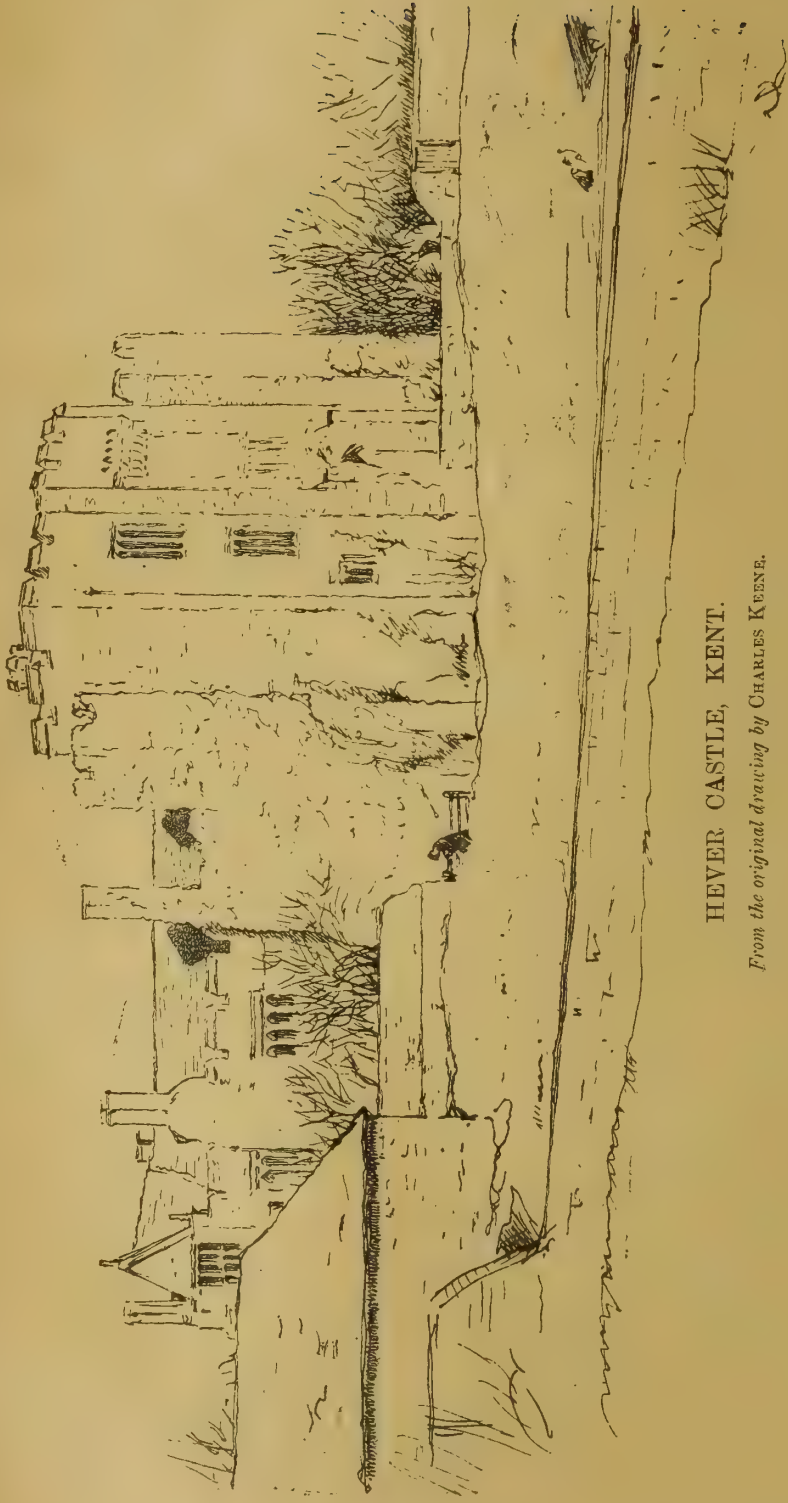

HEVER CASTLE, KENT.

*From the original drawing by CHARLES KEENE.*





AN OLD CHURCH.

*From the original drawing by CHARLES KEENE.*

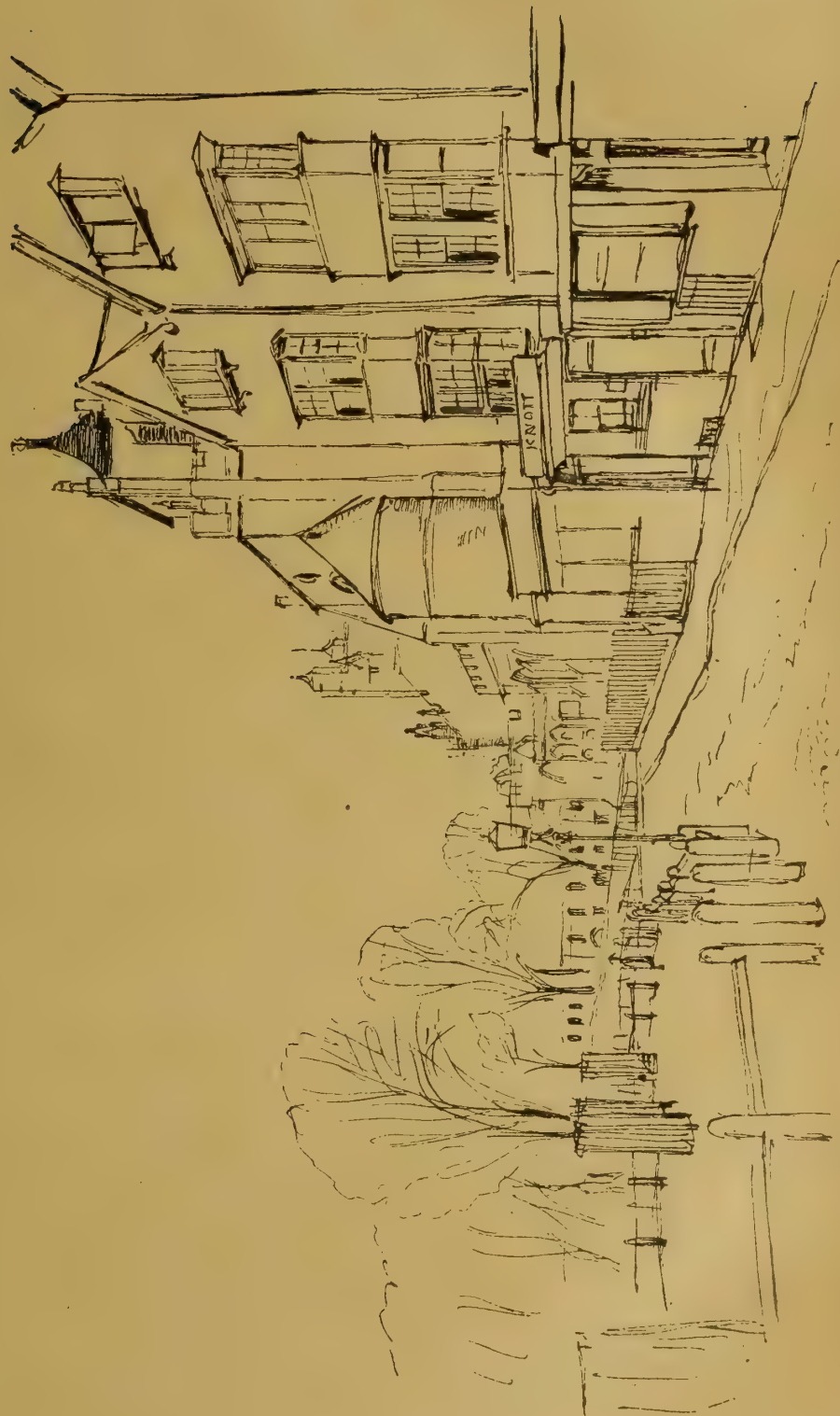

A SKETCH ON TURNHAM GREEN.

*From the original drawing by CHARLES KEENE.*

## Building Intelligence.

**NEWTON ABBOT.**—Lady Clifford opened on Friday the new Union Infirmary at Newton Abbot. It is erected on high ground at the rear of the workhouse. It comprises a central block, in which are twelve rooms, 17ft. by 14ft., nurses' day rooms, &c., and two wings with wards, 62ft. long by 24ft. wide. All are 11ft. high. At the rear, connected by covered ways, is another building, including three lying-in wards and five bedrooms for the nurses. Two of the lying-in wards are 22ft. by 22ft., and the other 15ft. square. The infirmary, which will accommodate 120 patients, has cost nearly £10,000. The architect was Mr. S. Segar.

### CHIPS.

We are glad to hear that the corporation of Botele have acceded to the representations of the Liverpool Master Builders' Association, on which we animadverted in our last issue, p. 79, and have withdrawn the objectionable clause in their advertisement for tenders for a new lodge at Derby Park, demanding that "persons tendering must submit their own schedule of quantities fully priced out, which must accompany the tender."

The Bishop of Oxford opened on Friday the Linton Memorial Schools, which have been erected in the parish of St. Peter-le-Bailey, Oxford, on a portion of the site of the old New Inn Hall, at a cost of nearly £4,000.

On Saturday, at Wolverhampton, Mr. George Armstrong, who lately retired after holding the position of superintendent of the northern division of the Great Western Railway system for many years, was presented with a number of gifts of the value of about £200, subscribed for by his colleagues and friends.

A new organ in Cotham Wesleyan Chapel, Bristol, built by Mr. W. G. Voules, of that city, was opened on Saturday. It is built in two parts, one being placed on either side of the organ chamber. The case was designed by the architects of the building, Messrs. Curwen and Jones, and the work has been carried out by Messrs. Stephens and Bastow, also of Bristol.

Mr. Philip E. Pilditch has been appointed as one of the surveyors and umpires to the Board of Trade.

The Primitive Methodist Chapel in West-street, Boston, Lincolnshire, which was destroyed by fire on January 28th, 1897, and has been rebuilt and renovated at a cost of about £2,000, was reopened on Friday. The architects were Messrs. Howdill, of Leeds.

The City and Waterloo Railway, which will give the London and South-Western Railway direct access from the Waterloo terminus to the heart of the city, will shortly be opened for traffic. The line itself was completed some time ago; but delay has occurred both by reason of the dispute in the engineering trade, and also in connection with the underground work which has had to be undertaken by the central London Railway Company at the new station opposite the Mansion House.

Archdeacon Sinclair appeals for £3,800, the balance still required of a sum of £5,000 for restoring the parish church of Bow, E. This parish church, one of the oldest in London, has been from time to time patched and repaired; but is now pronounced unsafe by Sir Arthur Blomfield, and has been closed during the last 16 months. In September, 1896, the roof of the chancel fell in. The original structure, although tottering to decay, still remains a correct specimen of the architecture of the early part of the 14th century, and, as Dr. Sinclair remarks, the tower forms a noble object in the middle of Bow-road, the whole length of which it dominates.

The city council of Liverpool have decided to purchase the Harbreck Estate at Fazakerley as a site for a proposed fever and small-pox hospital. The estate comprises an area of 113 acres, and the price to be paid is £37,150.

At Friday's meeting of the West Riding County Council, the general asylums committee reported that the plans for an asylum for private patients, to be erected at Scalebor Park, Burley, had received the provisional approval of the Lunacy Commissioners. Accommodation was provided for 210 patients (105 males and 105 females). The plans did not include the villa residences for the higher class paying patients, nor a chapel. The committee was empowered to erect an asylum at an estimated cost of £80,926. It was also agreed that works for the centralisation of the heating station and an installation for the supply of electric light at the West Riding Asylum at Wakefield should be carried out at an estimated cost of £16,000.

### LEGAL INTELLIGENCE.

**CONVERSION OF PRIVIES INTO THE WATER CARRIAGE SYSTEM AT ECCLES.**—In October last, at Eccles Petty Sessions, William Barnett, summoned by the corporation of Eccles, was ordered to abate the nuisance alleged to be caused by the defective ashpits and middens at the back of property belonging to him in Ellesmere-street, Patricroft, and to substitute in place of the ashpits water-closets, and covered dry receptacles for the dry ash tubs emptied by the corporation scavengers weekly. Mr. Barnett appealed against the decision of the borough magistrates, and the appeal was heard on Wednesday at the Salford Hundred Sessions held at the Assize Court. Mr. Goldthorpe, stipendiary, presided. Mr. Langdon and Mr. Pope, jun., appeared for the appellant, and Mr. Rhodes appeared for the corporation. After a hearing lasting over five hours, the Court dismissed the case, with costs against the appellant.

**THE BUILDING OF A WORKHOUSE: DREW-BEAR AND OTHERS V. THE ST. PANCRAS GUARDIANS.**—In continuation of our report last week, pages 77-8, we give to-day a brief summary of the proceedings on the last two days' hearing of this protracted arbitration case, which was heard by Mr. Justice Ridley, sitting without a jury, from Tuesday till Saturday last. The total claim from the defendant guardians was for £16,872, damages alleged to be due to plaintiffs as trustees for the builder of St. Pancras Workhouse, for not being able to obtain full possession of the site within six months of the date of the contract, and for interference by sub-contractors. Mr. R. M. Bray, Q.C., and Mr. A. A. Hudson represented the plaintiffs, and Mr. English Harrison, Q.C., and Mr. W. Moyses appeared for the defendants. William Henry Thurgood, F.S.I., of Great George-street, Westminster, said he had practised for 18 years past as a surveyor, and prior to that was a builder in an extensive way of business for many years. In April, 1893, he was called on to measure up the work at St. Pancras Workhouse for the plaintiffs, as the trustees of Brooks. He considered the charge made for loss resulting from the piece-meal possession given to plaintiffs was fair, having regard to the increased expenses thereby involved. He estimated the extra outlay under that head at, in the least, 12½ per cent. on the contract sum. Harry W. D. Theobald, F.S.I., 110, Great Russell-street, Bloomsbury, said he had acted as manager both to H.M. Office of Works and the War Office, and was the arbitrator selected by Kirk and Randall and the St. Pancras Board of Guardians in respect of the dispute between them as to the original contract for the workhouse, which, after Kirk and Randall withdrew therefrom, was taken over by Brooks. He regarded 12½ per cent. as a fair allowance for the delay in gaining possession, and for interference by such contractors. Cross-examined: Interference to the works was caused by ambulances and coal-trucks going backwards and forwards to the workhouse. William Henry Strudwick, F.S.I., late of 14, Parliament-street, S.W., now of New Inn Chambers, said he had been practising as a surveyor for 35 years. He agreed with the last two witnesses that 12½ per cent. was a fair addition to make to the contract price for the delay and interference. This closed the plaintiff's case. For the defence, A. Boden was called, and said he was chairman of the Building Committee of the St. Pancras Board of Guardians at the time the operations in question were being carried out, and he saw, from time to time, all the works during their execution. From first to last, during the carrying out of the contract, the witness Fearon, Brooks's manager and son-in-law, did not apply to him to be allowed to make an entrance between block H and the end of block A. The learned Judge remarked that clearly this was a matter for the architect, who gave the contractor one entrance instead of another. Witness, proceeding, said he never at any time gave Fearon an order to repair either of the two roads. Fearon never made any complaint to him that the roads were being used by the guardians. Alfred A. Millward, clerk to the St. Pancras Board of Guardians, said he never gave orders for the repair of the two roads, and never allowed any of the guardian's traffic to pass over either of those roads. If traffic did pass over them, it was contrary to his regulations. Captain Thomas Miller, the master of the workhouse, deposed that no traffic for the guardians passed over either of the two roads that had been mentioned while the contract was being executed. J. G. Deane said he acted as gatekeeper at the workhouse during the entire period that the inside works were being carried out. He kept a book recording all the carts and vans passing through the gates, and this showed no entry of a vehicle on the vestry's business going through. Heavy traffic was unloaded at the Commercial-street entrance, and the lighter goods at the receiving ward entrance. His lodge was close to the Vestry Hall, and his duty was to remain at his post all day. He did not remember Fearon calling his attention to carts coming in at the vestry entrance. William A. McCormick said he was a builder in the

Essex-road, and from his books he said there was no appreciable rise in the price of building materials in 1893. His Lordship: The suggestion is that the rise in prices took place in 1892. Mr. English Harrison thought the evidence rather tended the other way. The chief items in the contract were bricks and timber. Witness added that he had examined the invoices in his business for the purpose of ascertaining whether there was a rise in the price of bricks and timber in 1892. At the end of 1892 he could not detect any appreciable advance; but since 1895 there had been large strides. This closed the evidence for the defendants, and Mr. English Harrison addressed his lordship on behalf of the board of guardians, Mr. Bray replying on behalf of plaintiffs. At the conclusion of the legal arguments, his lordship said he would like a few days to consider the matter, and would give due notice to both sides as to when he would be able to pronounce his decision. Judgment accordingly reserved.

**RE ATHEERTON AND DOLMAN.**—The bankrupts were builders trading at Poplar, and a sitting for their public examination was held last week. The joint accounts showed liabilities amounting to £13,752, of which £10,852 were unsecured, and assets £4,255. The failure was ascribed to losses on contracts and depreciation in the value of the stock, plant, &c., as estimated for realisation. Mr. Hough appeared as Official Receiver, and Mr. Buckmaster for the trustee. The examination was concluded.

### WATER SUPPLY AND SANITARY MATTERS.

**THE LONDON WATER SUPPLY.**—The Royal Commission inquiry into this subject resumed its sittings on Monday at the House of Lords. Sir A. R. Binnie, chief engineer to the London County Council, gave statistics as to the population and rate of increase in inner and greater London, and the areas served by the nine water companies. The water supply was mainly derived from the rivers Thames and Lea, springs and wells in the Lea valley and wells in Kent. The witness quoted figures to show how nearly there might be an approach to the absorption of the whole flow of the Thames during comparatively long periods in the drier half of the year, and that the whole flow of the river Lea was practically absorbed in dry weather. The Lea Conservators afforded no protection to the public, because they were entirely overshadowed by the water companies. The witness referred to the bitter complaints which had reached the London County Council as to the shocking state of the Lea. He did not altogether accept the finding of Lord Balfour's Commission that the Thames and Lea were satisfactory sources of supply, and held it to be expedient that a portion of the supply should come from some other source. He would not abandon the present sources of supply, but would supplement them. Continuing his evidence on Tuesday, Sir A. Binnie said he was of opinion that the existing supply would have to be supplemented in ten or fifteen years, and was in favour of obtaining an additional supply from Wales, at a first outlay of over £14,000,000, and an ultimate expenditure of £26,000,000. The Commission adjourned till Monday.

The death is announced of Mr. Thomas D. Ridley, J.P., dock and railway contractor, Middlesbrough, which occurred at his residence, Willimotswick Villa, Coatham, on Friday, at the age of 73. Mr. Ridley has lived at Redcar for over a quarter of a century. He was formerly a member of the Kettletham Local Board, and for some time its chairman.

Mr. F. H. Tulloch held an inquiry at Menai Bridge on Friday touching an application made to the Board of Trade by the urban district council to grant a provisional order for the erection of a pier and pavilion and other works. Mr. Webster, C.E., of London, the engineer, whose design was adopted in open competition, explained that the pier would extend seawards in a southerly direction for a distance of 320ft., commencing at the east end of St. George's-road. He estimated the cost at £3,000, inclusive of the erection of a warehouse and waiting-room.

New offices for the West Ham School Board, which have been erected in The Grove, Stratford, were opened on Friday. The building has been erected from plans by Mr. W. Jacques, the architect to the board, and has cost, exclusive of the electric light installation, close on £14,000. The principal apartment is the board-room, 35ft. by 40ft. It has a low octagonal dome, each of the eight sides of which is fitted with a semi-elliptical window glazed with coloured glass. The members will be seated at separate desks arranged in a semi-circle in front of a dais for the chairman and principal officers. The floors throughout, and the greater part of the roof, are of steel and concrete, the paving of the corridors being of mosaic.



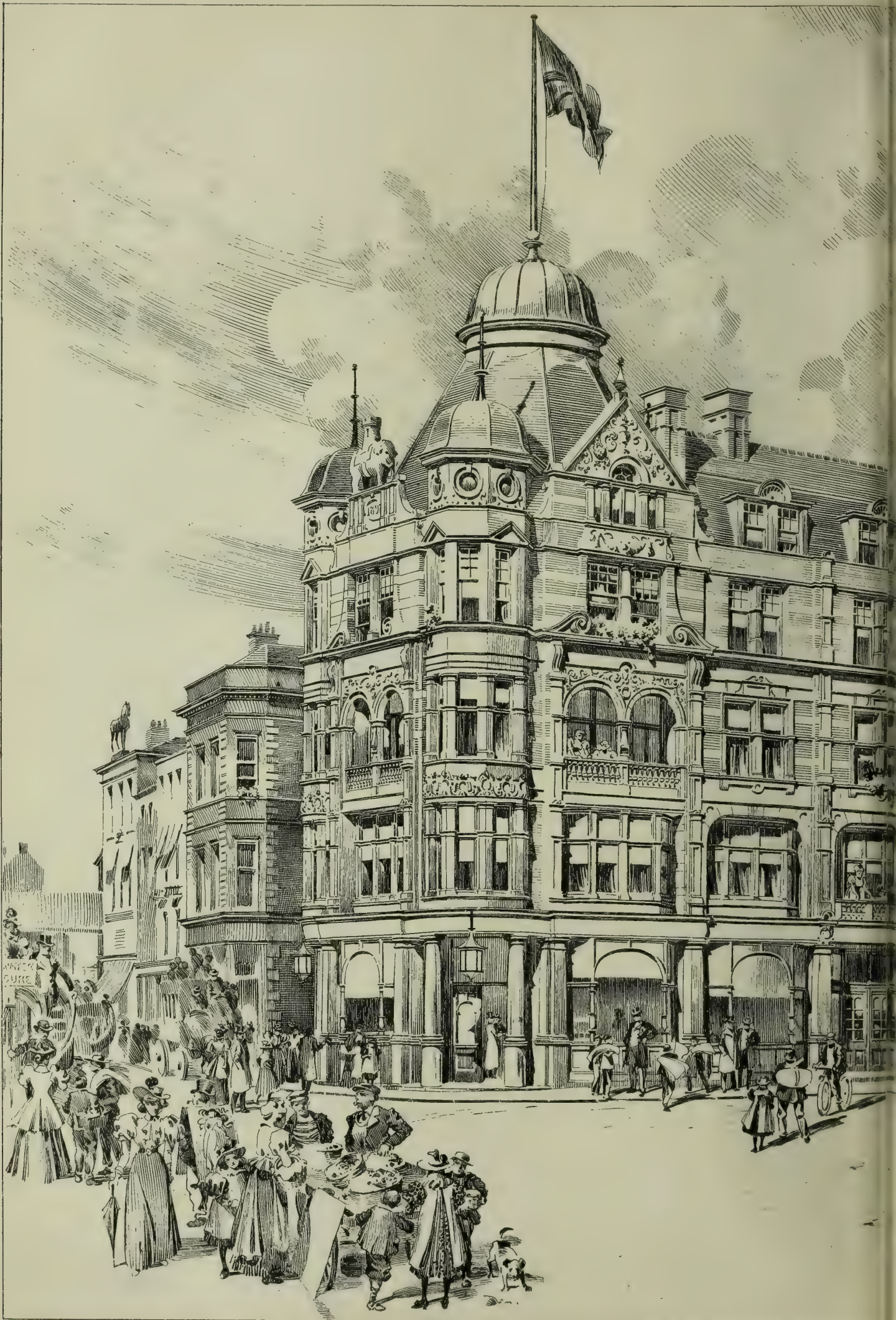



THE ELEPHANT &  
CASTLE ESTATE.  
PROPOSED REBUILDING  
FOR A MEEKINS ESQRE.  
MR JOHN FARRER,  
ARCHITECT.  
20 Finsbury Pavement









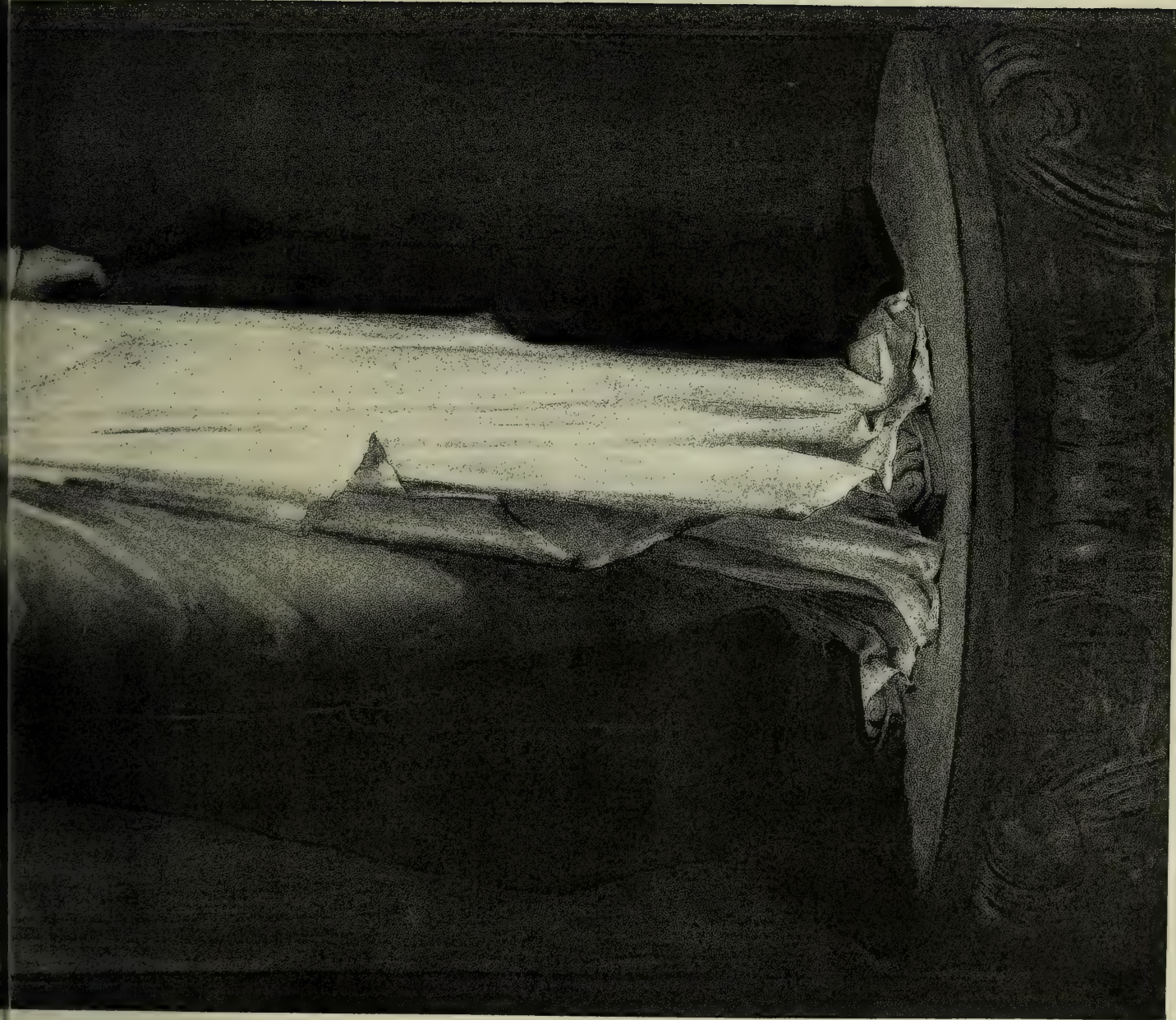

"Photo-Fit": by James Akerman, 6, Queen Square, London, W.C.

HERMIONE AS A STATUE (THE WINTER'S TALE) ROYAL ACADEMY SILVER MEDAL.

CARTOON OF A DRAPED FIGURE

BY MISS MARY TOLSON





B.N.D.C. GROUP OF STABLES:  
 " BUILDINGS:  
 BY B.Y.D.

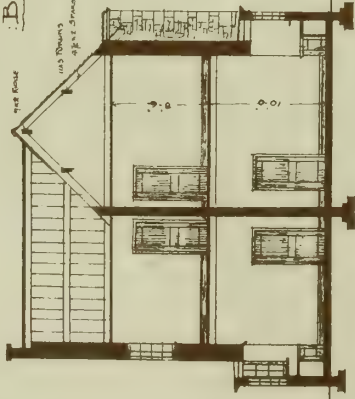

SECTION A B

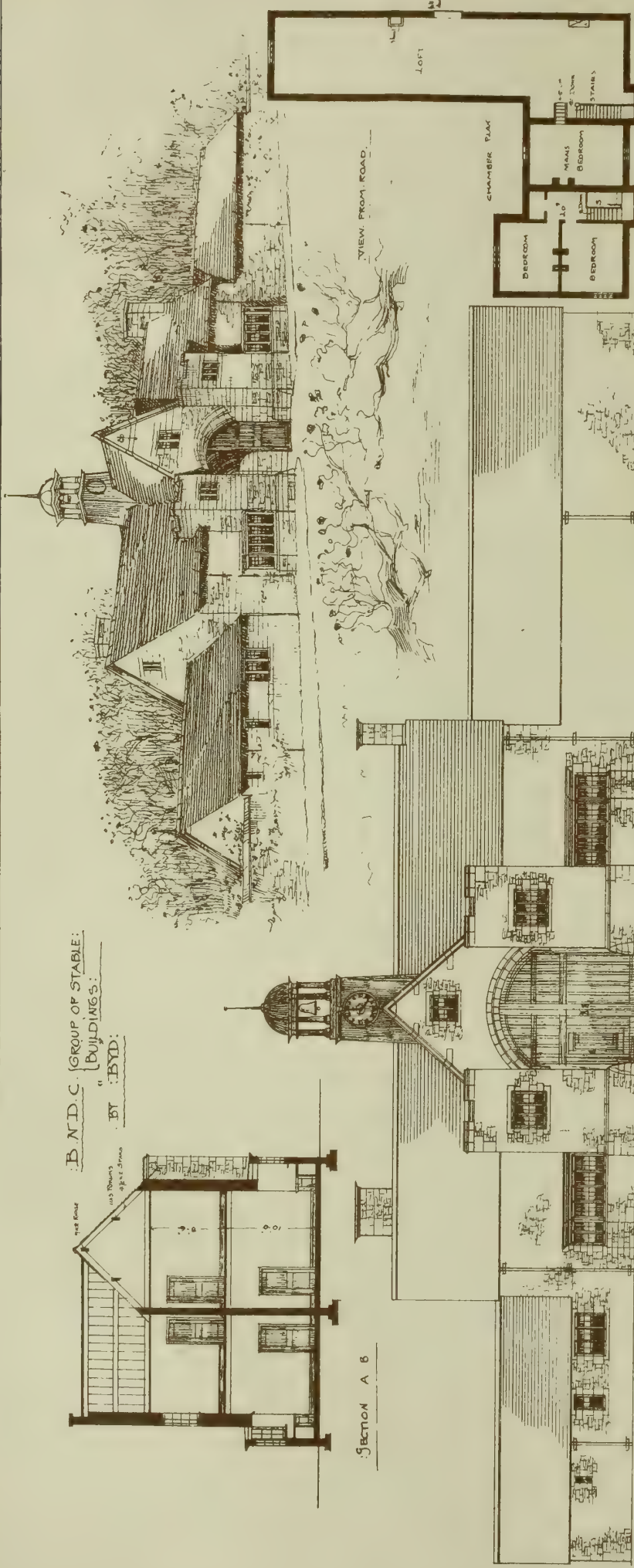

ELEVATION TO ROAD:

PLACED FIRST

FOR ELEVATIONS  $\frac{1}{8}$  SCALE

SCALE OF FEET FOR PLANS  $\frac{1}{16}$  SCALE

ELEV. FROM DRIVE:  $\frac{1}{8}$  SCALE.

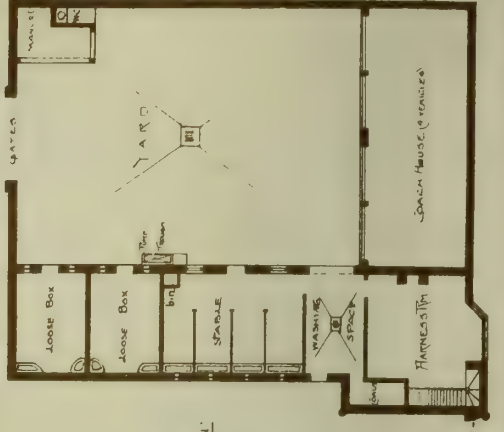

THE GROUND PLAN

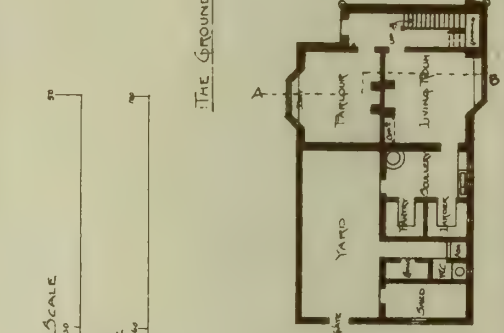





THE BUILDING NEWS, JAN. 21, 1898.



WALTHAMSTOW PUBLIC BATHS COMPETITION DESIGN PLACED FIRST J. WILLIAMS DUNFORD ARCHT

PHOTO-TINT BY JAMES AKERMAN 6 QUEEN SQUARE LONDON W.C.

"SUMMERDALE" EPSOM SURREY J. HATCHARD SMITH FRIBA ARCHT.



Ground Plan

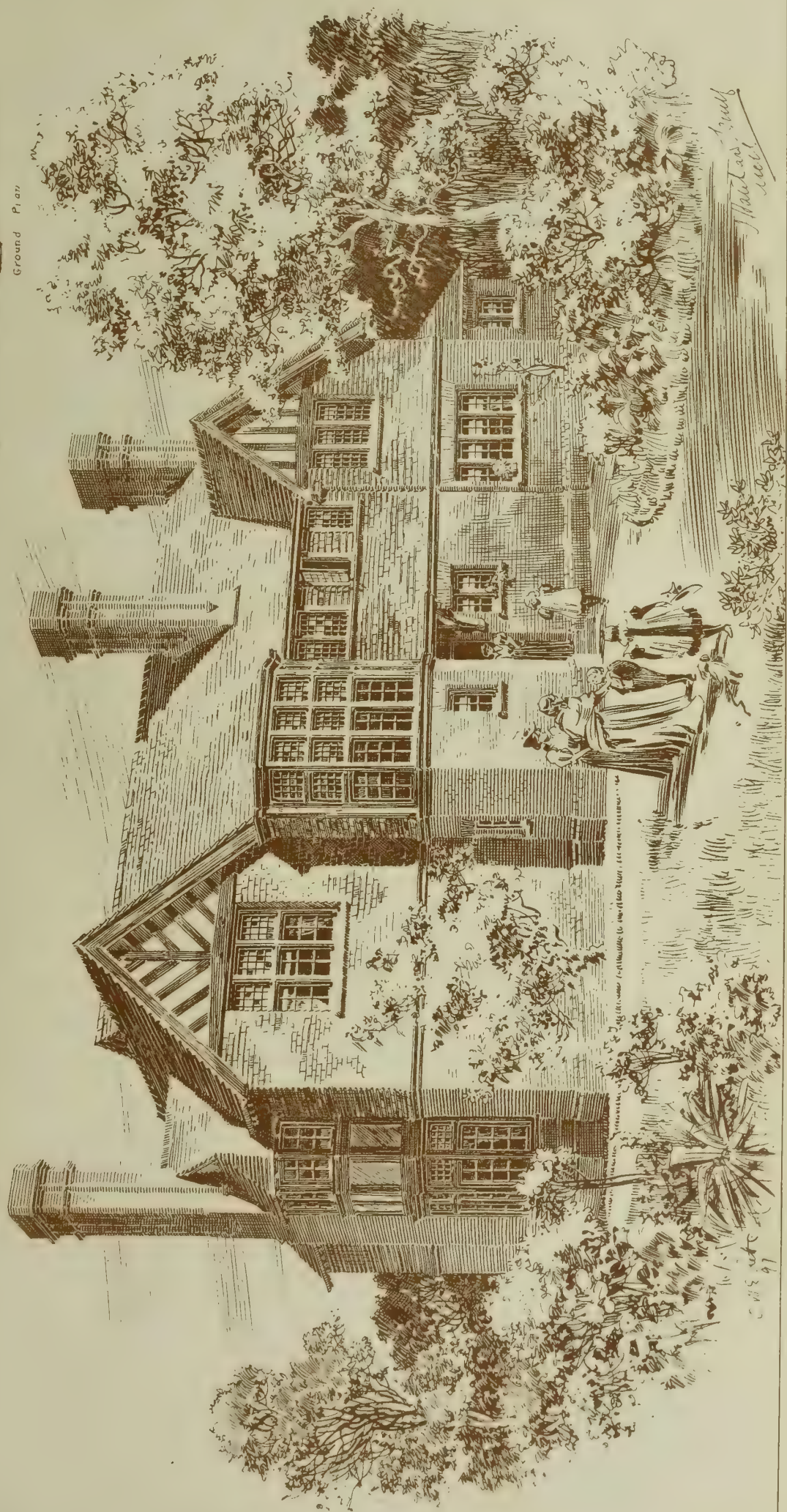



PLACED SECOND

BY BANTAM

DESIGN FOR:  
A GROUP OF STABLE BUILDINGS:  
SUITABLE TO A STONE DISTRICT:

TO COST \$1500:

DECEMBER 1897:

THE GROUND PLAN:

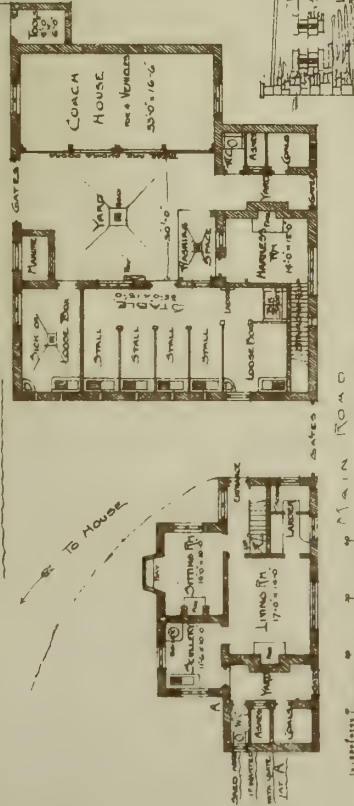

SCALE OF FEET TO THE ROAD:

THE FIRST FLOOR PLAN:

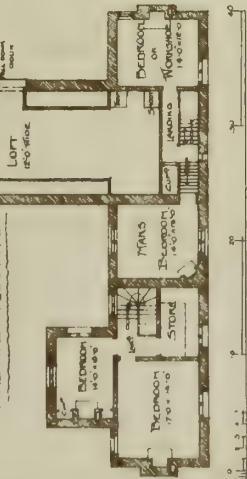

SCALE OF FEET TO THE ELEVATIONS AND SECTIONS:

ELEVATION AND SECTION THRO' HARNESS ROOM:

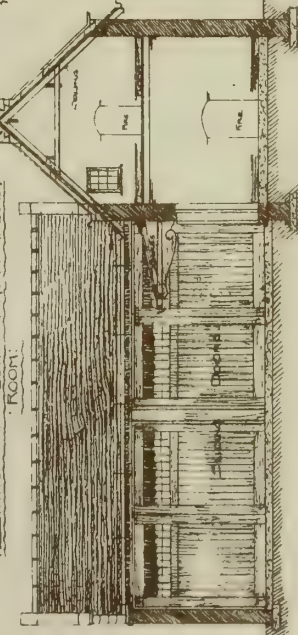

FRONT ELEVATION FROM THE MAIN ROAD:

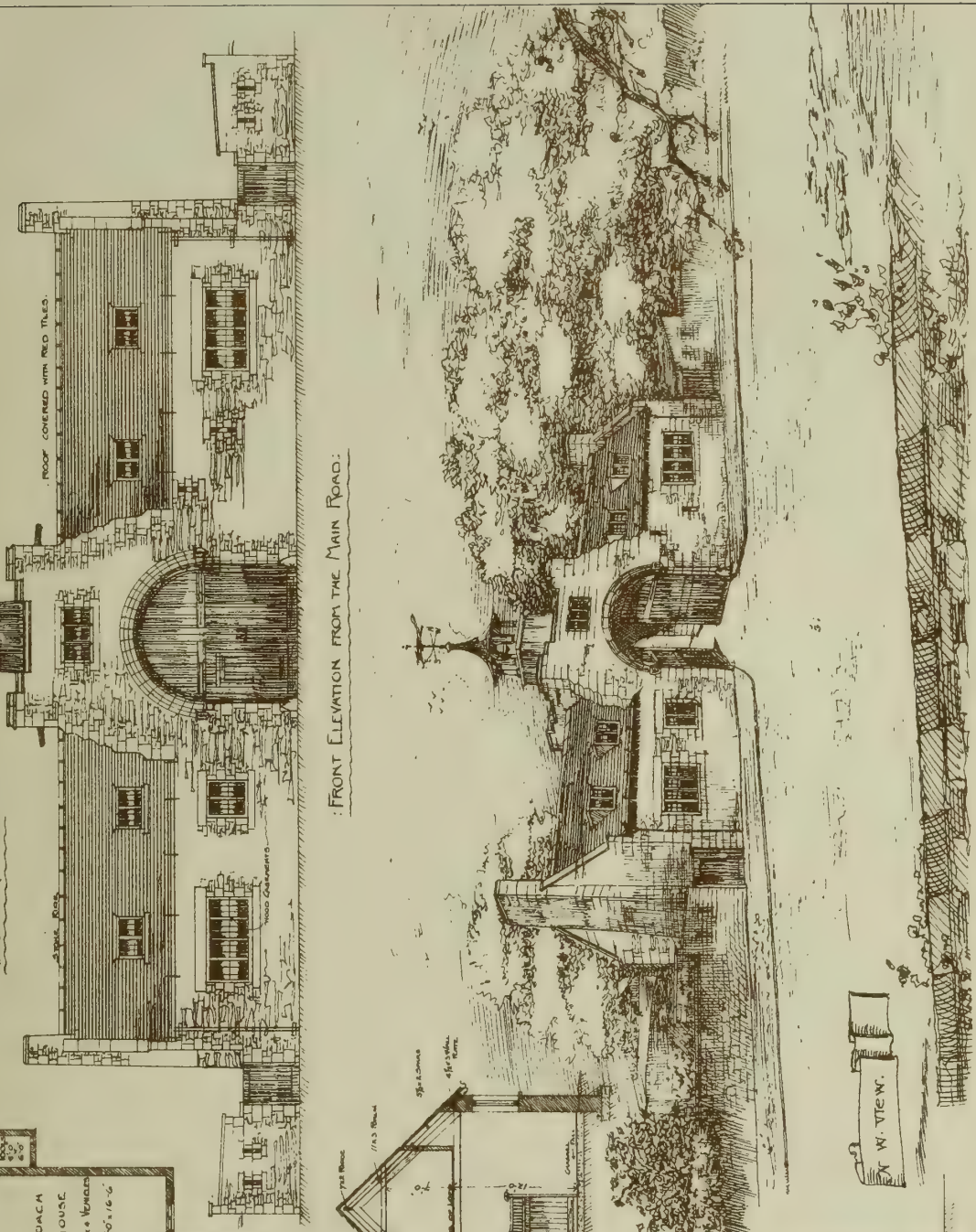

A W. VIEW.

THE  
LIBRARY OF THE  
MUSEUM OF COMPARATIVE ZOOLOGY  
AT HARVARD UNIVERSITY

**TO CORRESPONDENTS.**

[We do not hold ourselves responsible for the opinions of our correspondents. All communications should be drawn up as briefly as possible, as there are many claimants upon the space allotted to correspondents.]

It is particularly requested that all drawings and all communications respecting illustrations or literary matter should be addressed to the EDITOR of the BUILDING NEWS, 892, Strand, W.C., and not to members of the staff by name. Delay is not infrequently otherwise caused. All drawings and other communications are sent at contributors' risks, and the Editor will not undertake to pay for, or be liable for, unsought contributions.

Cheques and Post-office Orders to be made payable to THE STRAND NEWSPAPER COMPANY, LIMITED.

**TERMS OF SUBSCRIPTION.**

One Pound per annum (post free) on any part of the United Kingdom; for Canada, Nova Scotia, and the United States, £1 6s. 0d. (or 6dols. 30c. gold). To France or Belgium, £1 6s. 0d. (or 33fr. 30c.) To India, £1 6s. 0d. To any of the Australian Colonies or New Zealand, to the Cape, the West Indies, or Natal, £1 6s. 0d.

**ADVERTISEMENT CHARGES.**

The charge for Competition and Contract Advertisements, Public Companies, and all official advertisements is 1s. per line of eight words, the first line counting as two, the minimum charge being 5s. for four lines.

The charge for Auctions, Land Sales, and Miscellaneous and Trade Advertisements (except Situation advertisements) is 6d. per line of eight words (the first line counting as two), the minimum charge being 4s. 6d. for 40 words. Special terms for series of more than six insertions can be ascertained on application to the Publisher.

Front-page Advertisements 2s. per line, and Paragraph Advertisements 1s. per line. No Front-page or Paragraph Advertisement inserted for less than 5s.

Advertisements for the current week must reach the office not later than 3 p.m. on Thursday. Front-page Advertisements and alterations in serial advertisements must reach the office by Tuesday morning to secure insertion.

**SITUATIONS.**

The charge for advertisements for "Situations Vacant" or "Situations Wanted" is ONE SHILLING FOR TWENTY-FOUR WORDS, and Sixpence for every eight words after. All Situation Advertisements must be prepaid.

**NOTICE.**

Bound copies of Vol. LXXII. are now ready, and should be ordered early (price Twelve Shillings each), as only a limited number are done up. A few bound volumes of Vols. XXXIX., XL., XLI., XLII., XLIII., XLIV., XLV., XLVI., XLVII., XLVIII., XLIX., L., LI., LII., LIII., LIV., LV., LVI., LVII., LVIII., LIX., LXX., LXXI., LXXII. may still be had, price Twelve Shillings; all the other bound volumes are out of print. Most of the back numbers of former volumes are, however, to be had singly. Subscribers requiring any back numbers to complete volume just ended should order at once, as many of them soon run out of print.

RECEIVED.—S. M. C. and Son.—D. S. N. (Bristol).—H. G. B. and Co.—W. F. L.—A. S. C.

**Correspondence.**

**"A PARALLEL TO WALTHAMSTOW."**

To the Editor of the BUILDING NEWS.

SIR,—I have received from Messrs. Wontner and Sons (solicitors to Messrs. Spalding and Cross) a communication complaining, on behalf of their clients, of my letters on this subject in the BUILDING NEWS. The essential part of this communication is given in my reply to it, which I shall be glad if you will publish below.—I am, &c., JAMES CUBITT.

2, Broad-street Buildings, E.C.

To Messrs. Wontner and Sons.

GENTLEMEN,—I have to acknowledge the receipt of your letter of the 14th inst., complaining, on behalf of Messrs. Spalding and Cross, of two letters of mine in the BUILDING NEWS, and specifically of certain remarks in the first of these, which was published on December 17, 1897.

You say that in this letter I "commence by stating that 'it is the duty of every honest man to aid in letting daylight into the dark and dirty corners of architectural practices' [sic], and as an example of these 'dark and dirty practices,' that I "then proceed to quote certain doings of Messrs. Spalding and Cross." This complaint is entirely based on a serious, though doubtless inadvertent, misquotation of my words, which alters their meaning, and puts an erroneous construction on my whole letter.

I made no mention whatever of "practices." What I wrote about was architectural practice; and I meant by this phrase what it usually does mean—namely, architectural business, and the conduct of architectural matters, whether by architects or by the multitude of other persons who at one time or another have to do with them. It is with the architectural practice of these other persons, in appointing and removing architects, that my letter of December 17 mainly deals; and this is evident, even in the very next words which follow those you have quoted. I have never described any "doings" of Messrs. Spalding and Cross as "dark and dirty practices," and it is only through the serious misquotation which I have pointed out that it becomes possible

to make it appear I have done so.—I am, gentlemen, your obedient servant, JAMES CUBITT.

P.S.—As Messrs. Spalding and Cross thought well to announce in the last issue of the BUILDING NEWS that they had placed this matter in your hands, I am sending a copy of this letter to that journal for publication.—J. CUBITT.

**WALTHAMSTOW PUBLIC BATHS.**

SIR,—I think it is grossly unfair on the part of Messrs. Spalding and Cross to charge me with publishing "misleading and untrue statements" without supplying cases in confirmation thereof.

The quibble as to whether the £25 or guineas they received was accurately described as a "second premium" when there were only two competitors, requires no further comment.

Have they returned the money?

On looking over the correspondence, I find that many of my statements are supported by independent and reliable evidence, and in other cases I have asked Messrs. Spalding and Cross for the truth, and with what result?—they have deliberately ignored my requests.

To charge me with making "misleading and untrue statements" under such circumstances is simply scandalous.

Now, what is the reason which has induced Messrs. Spalding and Cross to reappear in this matter after deliberately stating that they could not continue the correspondence? It is not far to seek. I venture to submit that, having failed to justify their position from a professional point of view, they have unwittingly rendered it exceedingly difficult for their special pleader to justify his position at the forthcoming District Council election. The influence of this correspondence has been making itself felt in the district, and consequently we find Messrs. Spalding and Cross now being made the mouth-piece of the views of their special pleader, whose action has been so severely commented upon. I have nothing to suppress, and therefore will subject their one-sided semi-official statement, based, not on the action of the Council, but on the action of Committees, to as close an analysis as I hope I have hitherto treated their unofficial observations.

(1) Messrs. Spalding and Cross say that, "long before Mr. Dunford's name was suggested in connection with the proposed work, we were practically engaged by the council to prepare the necessary working drawings for the baths." You have already been informed how Mr. Spalding first came before the council, and, as the story has not been denied, but simply described as "inaccurate," it will bear repeating:—

"A member of a firm of architects hearing, quite by accident (of course), that baths were to be constructed at Walthamstow, armed himself with plans, came down to Walthamstow, and, by the merest chance, called upon one of the rank and file of the council, who was a perfect stranger to him; called, too, on the very night that the works committee were to meet, and through this 'chance' visit secured an interview that very night."

The Walthamstow Guardian (Dec. 10, 1897), commenting upon this, says:—"How very pretty; how entirely probable. Tell it to the marines, or to the youngest children in an infant-school, and just possibly it might be taken in." Once again I ask for the truth. The statement that they were "practically engaged" has been made before, and answered as follows at a council meeting:—

Mr. McSheedy: They had practically appointed Messrs. Spalding and Cross eighteen months ago. ("He was invited into the Committee, and picture-plans were submitted, which were so elaborate that the Committee actually appointed him."—Herald report.)

Mr. Good: I should like to see the resolution appointing them.

Mr. McSheedy: I say we had practically got to the appointment of these gentlemen.

Mr. Good: No.

Mr. Ogilvie: It was not true that Messrs. Spalding and Cross were appointed eighteen months ago. They never had been appointed.

Mr. Finch: You say you had practically appointed Messrs. Spalding and Cross, Mr. Spalding being introduced by Mr. McSheedy; but they never were appointed.—Guardian report, Nov. 19, 1897.

I believe it is perfectly true that the clerk to the council was instructed to write to the various public bodies for whom Messrs. Spalding and Cross had erected baths to ascertain what were the original estimated costs, and what was the final expenditure incurred, and I believe it is also perfectly true that the following statement was made at a council meeting:—

"It was admitted that the baths and washhouses erected in various parts of the country by Messrs. Spalding

and Cross had not, in several cases, been carried out for the sum named."—Guardian, April 9, 1897.

Whether this statement is correct or not I cannot say; but on receipt of the figures, when Mr. Spalding's friends were in a minority, they clamoured loudly and publicly for their publication. Since reaching the position of a majority they have displayed a curious and interesting reticence in connection therewith.

Messrs. Spalding and Cross appear to imagine, in conjunction with their special pleader, that the above instruction to the clerk ("They thought it a *bonâ fide* suggestion . . . so they voted for it."—Mr. McSheedy) was merely an electioneering move.

When did this view of the case first dawn upon them? Was it after the reception of Mr. Plumble's report?

Although builders as a rule are not averse to extras in their own business, you will generally find that on public bodies they are very severe on architects in this respect. The suggestion to apply to other authorities for information—emanating as it apparently did from gentlemen engaged in the building trade—does not surprise me, and certainly does not strike me as an electioneering move. However, let Mr. Spalding ask the gentleman who moved the resolution. He will have an early opportunity.

(2) It is true that after Mr. Plumble's report was received it was decided in committee—no doubt with the object of satisfying the impertinence of the special pleader—to ask Messrs. Spalding and Cross to appear before the next committee to pledge themselves to erect the baths for the sum named! The actual date of this meeting I do not know, but it must have been early in February (1897), and about the time of the Walthamstow Parliamentary Election. At this period the following telegram was published (Feb. 5):—"To J. J. McSheedy. Hearty congratulations on your (!) brilliant victory. Spalding." Did this telegram refer to the election, or did it refer to the victory gained in committee? However, telegram or no telegram, the majority altered their views before the council meeting. (Is it an unheard-of arrangement for a council to upset a clause in a committee's report?) The reasons were set forth at the time in a letter which appeared in the Guardian (March 5), and from which I take the following extract:—

At the special committee a prominent member of the opposition said there was no hurry for the baths. (Note.—Mr. Spalding's "chance" visit was eighteen months before.) In my opinion time enough has been wasted; obstruction has been well kept up, and now the prominent member, if I understand him, wishes to put the matter off, so that he may at election time misrepresent, and make it appear that the members on the other side have caused the delay.

Here we have direct evidence that Mr. Spalding's special pleader was endeavouring to bring about what they now complain (without the slightest justification) the other side did twelve months before—viz., to delay the selection of the architect until after the election.

I "do not know to what extent the machinations on the part of their principal supporter were approved or instigated" by Messrs. Spalding and Cross; but I "do know that they were prepared to benefit by the results calculated to be achieved."

(3) Messrs. Spalding and Cross further say:—"The third council at once rescinded the resolution carrying Mr. Dunford's appointment on the ground that it was obtained by a 'gross act of jobbery.'" I think it must be impossible for anyone who has carefully read the foregoing to avoid drawing the conclusion that Messrs. Spalding and Cross must have sunk very low indeed to prefer in your columns such a rash and hasty charge.

I venture to say that it is a deliberate insult not only to Mr. Rowland Plumble, but to every member of the Council who has confirmed that gentleman's decision.

What evidence have they cited in support of this charge?

(1) That the minority of the 1895 Council declined to take Messrs. Spalding and Cross at their own or at the valuation of their special pleader.

Has it come to this?—that one man out of twenty-two is to be allowed to select the architect of a public institution, and if he is not allowed to have his way, that the majority of his colleagues are to be described through his nominee as "jobbers."

(2) That the majority of the 1896 council refused to allow Messrs. Spalding and Cross to appear before them to state how they were going

to carry out their scheme for £7,000! (Since raised on their appointment to £8,500). I have no authority to defend the action of any particular section of the council, and, therefore, in dealing with this matter, shall chiefly confine myself to recorded evidence.

I shall submit that they were perfectly justified, apart from the approaching election, as explained above, for two reasons. First, they had already paid a heavy fee to Mr. Plumbe to advise them on the point, and he said it could not be done for anything like the money. Secondly, they had within their own ranks gentlemen possessing experience of the building trade who were quite able to gauge the fact for themselves; as will be seen from the following dialogue which took place at council meetings:—

Mr. Good: As a builder of many years' standing, said, when they referred the plans to M. Plumbe, they agreed to abide by that gentleman's decision as to plans for carrying out the work as near £7,000 as possible. Mr. Plumbe said in his report that Mr. Dunford's plans were best for the price, although those of Messrs. Spalding and Cross were better in other respects. He was afraid the latter firm had not considered the cost in preparing their plans. He went on to say that the plans of Spalding and Cross must involve a much heavier outlay.

Mr. Ogilvie: As a builder with over 40 years' experience, he had no hesitation in saying that the plans prepared by Messrs. Spalding and Cross could not be carried out for anything like £7,000. They had gone in for what he believed would be an expensive building. If they had plenty of money to spare, and could spend £12,000, he would support them in putting the matter back, for no doubt Mr. Dunford could give them a very different building for that amount. Mr. Dunford's plans had first place, and he should support sealing the contract.—*Guardian*, April 9, 1897.

Mr. Finch: If I had done in the case of Mr. Dunford what had been done in the other case, no doubt insinuations would have been made; but I make none against Mr. McSheedy. He says we have been guilty of trickery, and I say, if we had done what he has done with Messrs. Spalding and Cross there might be some foundation for it, but we have not done such a thing, and I have never discussed with Mr. Dunford the subject of the plans. Messrs. Spalding and Cross were said to be rattling good men, and no doubt they were; but they did not keep within the margin, and the arbitrator said their plans were not economical. Mr. Dunford did endeavour to keep to the price, and it was unfair to say there was jobbery. It was not right, honest, or fair, and it was immoral to rescind the appointment.—*Guardian*, Nov. 19, 1897.

The *Guardian* of the same date says, in the course of a leading article, "there is not a shadow of foundation for the accusations of trickery and jobbery made with reference to Mr. Dunford's appointment." In the face of these facts will Messrs. Spalding and Cross repeat their charge?

These gentlemen are anxious to know who said their design was placed second. The following is a copy of the official resolution. "That in accordance with the award of Mr. Rowland Plumbe, the author of the design under motto 'Hygiene' be appointed architect for the public baths, subject to the drawings being approved by the Local Government Board, and that the agreed sum of £25 be paid to the author of the design placed second under the motto 'Experience.'"

I have examined the article referred to by Messrs. Spalding and Cross in a local sheet edited by the special pleader, and find, first, that Messrs. Spalding and Cross's letter now under consideration incorporates all its salient points; and, secondly, that the letter and article are similarly constructed, thereby raising inferences of an obvious character.

In conclusion, permit me to say that I have had no communication whatever with any member of the late or present council as to the interpretation to be placed upon the acts of committees in contradistinction to the judgment of the late council.—I am, &c.,

J. WILLIAMS DUNFORD.

100c, Queen Victoria-street, E.C.

THE CARDIFF COMPETITION.

SIR,—Mr. Waterhouse's silence in regard to my charge of remissness in checking the cubic contents may be discreet, but is not what we, as competitors, are entitled to. Surely, if the profession rely on Mr. Waterhouse's judgment, they are entitled to some justification of his action in this matter.

I, for one, am not disposed to let the matter rest, having had to suffer once from a parallel case. Hence, I have had the cubic contents of the first and second prize designs carefully measured. The result is as follows:—

FIRST PRIZE DESIGN.

Town Hall, 3,006,935ft., at 11d. ....	£137,817 17 1
Law Courts, 2,334,750ft., at 10½d. ....	102,145 6 3
	£259,963 3 4

SECOND PRIZE DESIGN.

Town Hall, 2,991,396ft. at 11½d. ....	£146,459 12 9
Law Courts, 1,947,475ft., at 11d. ....	89,259 5 5
Basement of Town Hall (not shown on published drawings), say .....	5,000 0 0
	£240,718 18 2

NOTE.—The prices per cubic foot are competitors' own figures.

Outside the important question of ignoring the conditions (and you are entitled to our thanks for the trenchant remarks *re* this in this week's leading article, p. 51 *ante*), the profession is entitled to have the matter of exceeding the cost cleared up. It is time a stand was made when a mis-carriage of justice like this takes place, and I hope Mr. Waterhouse for his own credit's sake will not let the matter rest where it is, but "do justice, though the heavens fall."—I am, &c., NEMO.

Intercommunication.

QUESTIONS.

[11884].—"Red" and "Yellow" Deal.—Will a practical reader define these terms, and how they can be distinguished? Textbooks leave the student hopelessly in the dark: they merely distinguish the tree and the general uses, but give no information as to which kind is to be used for any particular sort of work. The Latin or botanical name for each of these building designations ought to be made clear, and I am glad that D. Forbes-Smith, in a letter in last week's "B.N.," has called attention to the subject. All architects would rejoice to see a better classification.—A LEARNER.

[11885].—"Foreign Slates."—What are the kinds of slates imported from America and other countries? Are they reliable and non-porous? I shall be glad of any information and prices.—COUNTRY BUILDER.

REPLIES.

[11882].—Brickwork Facing Measurement.—Facings are measured as extra per foot super, on the common brickwork. It is usual to take the gables by the width and half the height. The reveals of windows are measured the whole depth. For gauged walls, the face and soffit. There is an example given in Leaning's "Quantity Surveying." It is customary to deduct any facings of the stock brickwork, and then measure the facings if of red brick.—G. H.

[11882].—Brickwork Facing Measurement.—Collect the lengths of walling from plan, and put the total down as one dimension, and under it the height to, say, plate level. This will make one sum for the round of walls up to the gables. Then take the gables separately, height by width, and halve it in each case, and these sums are added. Describe the bricks, pointing, &c. It is best to take the gables separately, so as to be able to dissect the work if necessary.—A SURVEYOR.

At Friday's meeting of the Salford Board of Guardians, the building committee recommended the board to authorise them to make an offer of £14,000 for a plot of land at Hope, containing about twenty acres, adjoining land already in possession of the guardians, as the site for the proposed new workhouse for the union. The recommendation was adopted after a discussion.

The new operation rooms at the North Staffordshire Infirmary, at Stoke-on-Trent, were formally opened last week. All the old fittings are replaced by suites, wash-basins, and shelves made specially by Messrs. Twyford's, Limited, the flooring being of terrazzo, and the walls of specially-made tiles by Messrs. Wedgwood and Sons. The alterations have been carried out by Mr. T. Goodwin, builder, from the designs of Messrs. Lynam, Beckett, and Lynam, of Stoke-on-Trent, at an estimated cost of £1,000.

At the last meeting of the St. Olave's Guardians, ten tenders were opened for the erection of a new workhouse at Ladywell, Catford. The building is to accommodate 800 persons, and the architects' estimate was £156,000. The successful firm were Messrs. Shillitoe, of Bury St. Edmunds, whose tender was £158,785. A motion by Mr. Collins that the work should be confined to London firms was negatived; but a resolution was adopted requesting Messrs. Shillitoe to give consideration to the claims of London workmen, and especially to residents in St. Olave's Union.

Mr. J. Loughborough Pearson, R.A., of 13, Mansfield-street, who died on the 11th ult., leaving personal estate of the value of £51,943, left a will dated July 6, 1875. The sole executor of his will is his son, Mr. Frank L. Pearson, architect. The testator bequeathed to his valued and faithful assistant, John Codd, £300, and expressed the hope that his son would avail himself of the services of the said John Codd. Mr. Pearson directs his son, within six months after the testator's death, to purchase two annuities of £60 each, one for the testator's sister Sarah, widow of Mr. Hutman, of Amsterdam, and one for his sister-in-law, Sarah Christian. He gives the entire residue of his estate to his said son absolutely.

Our Office Table.

The result of the elections at the Royal Academy on Wednesday evening is that Mr. George Aitchison, who, since Mr. G. E. Street's death in January, 1882, has been the Professor of Architecture at the Academy Schools, and is now serving a second year of office as President of the Royal Institute of British Architects, is advanced from the rank of Associate to full Academician, thus taking the seat among the forty held since 1880 by Mr. Pearson. Professor Aitchison was elected as an A.R.A. nearly seventeen years ago, and, as the *Standard* says, as "an architect had to be chosen to the higher grade of the Academy, there was no reason to refuse him the distinction, though his claims may scarcely be said to have called loudly for it." The second associate promoted to full honours is Mr. Edward John Gregory, landscape and portrait painter, a brilliant colourist. Popular opinion had anticipated that the choice would fall on Mr. B. Williams Leader, who, like Mr. Gregory, became an associate in 1883; but his turn will probably come next month when two other academicians and an associate are to be chosen. The new associates are both *genre* painters.—Mr. Lionel P. Smythe and Mr. H. H. La Thangue.

A LECTURE on "Composition in Architectural Studies" was delivered before the Edinburgh Photographic Society on Friday by Mr. Hippolyte J. Blanc, R.S.A., architect; and by a coincidence Mr. F. T. Baggallay was at the same hour dealing with the topic of Composition in Architecture, regarded, however, from the view point of the designer, and not that of the photographer, before the members of the London Architectural Association, as fully reported on another page of our issue. Mr. James Patrick, the president of the society, occupied the chair. At the outset Mr. Blanc suggested a definition of composition to show the different conditions under which composition has to be considered by the painter, the sculptor, and the architect. The painter worked upon a surface of canvas which he could alter and treat according to his will, but which, when done, did not change. The sculptor did his work, like the architect, in his studio, but when brought out to the light of day and put in position, not one aspect of it only was viewed, but it was surveyed from all sides, and therefore, he said, the architect and the sculptor had to make their compositions pleasing from many points of view. He pointed out that the photographer of architectural studies was under the same disadvantage in that the group photographer could pose his subject in front of his camera, but the architectural photographer had to bring his camera round and round his building or group of buildings until he found out the best position from which he could obtain the most satisfactory picture.

DURING the demolition of St. Michael's Church, Wood-street, Cheapside, a small window, consisting of three quatrefoil lights arranged in a triangle, was discovered in the south wall. This, with some fragments of stained glass, exhibiting delicate tracery and foliate designs, some encaustic tiles, with cream-coloured patterns upon a red ground, and portions of an early stone coffin, have been secured for the Guildhall Museum. These remains date from about the 14th century, the window having probably been built up when the church, which suffered during the Great Fire, was re-erected by Sir Christopher Wren in 1673. The Old Bell Inn, Holborn, one of the last of the galleried hostelries, has also contributed a relic to the museum. It is a sculptured stone, bearing the arms of the Fowlers of Islington, who probably once owned the property. Other objects recently acquired for the museum include a little Roman scent-bottle, of a rare type, from Ivy-lane, Newgate; a tiny olla, decorated with raised bosses; a group of 17th-century pewter and pottery, from Great Chapel-street, Oxford-street; and several examples of pottery and glass, tobacco pipes, keys, &c., from the various City excavations. The library committee of the Corporation have presented to them a report announcing the completion, in manuscript, of a catalogue of the antiquities in the Museum. The committee suggested that the catalogue should be printed on demy quarto paper, that one section should be published first with good illustrations, and that one-half of the edition of 1,000 copies should be placed on sale. With that



view they asked for £100 to print as large a portion of the catalogue as that sum would allow, reserving for a future report the question of printing a smaller edition of the catalogue, without illustrations. The question came before the Corporation last week, with the result that the report was referred back for reconsideration, with especial reference to the ultimate cost of the catalogue as a whole, and having regard to the fact that over £1,000 has already been spent in arranging and cataloguing the antiquities. At the same meeting £700 was voted for general repairs to the building of the Guildhall Library and a rearrangement of the reading-room.

THE secretary to the Edinburgh Building Trades Exchange, Mr. John Nicoll, has sent the following letter to the chairman of the committee of contributors to the Royal Infirmary in that city with reference to the tenders for the new pavilion:—"The committee of the Building Exchange consider it their duty to the public to draw attention to the large increase in the tenders accepted over others before the board. My committee consider that the excess is so great as to call for inquiry and explanation. For example, the accepted tenders for mason and joiner work are £18,628. One lower offer at least, from responsible and well-known contractors who have carried out extensive works in this city and all over Scotland, was £17,008—excess, £1,620. Plumber—accepted, £3,188; rejected, £2,925—excess, £263. And there is a prevalent belief that the tenders for other work have been dealt with in the same manner. It is conceded that there was no obligation on the board to accept the lowest offers, but, on the other hand, when the funds involved relate to the building of a public charity, it is obvious that such exceptionally high offers should not be accepted without explanation, of which none has been vouchsafed. The difference in money is a serious matter, both to the institution and to the public. Moreover, there is no use inviting competitive offers if lower offers of equal, if not better, business standing than higher offers are rejected, and the higher offers accepted according to the whim of the board for the time being, or of those having influence with it."

A FEW days ago some experiments took place on the No. 6 section of the Birmingham Waterworks Scheme at Rubery Hill (Mr. A. Kellett's contract). The whole of a hillock, and some 20ft. below the ground level, in close proximity to Rubery Station, had to be blasted for the purpose of concreting the bottom of the new reservoir now being constructed at Frankley Lodge. The problem to be solved was how to blast the rock (which is of a very flinty nature, lying in beds with partings of clay between) without dispersing the same over the line and station. Any of the nitro-glycerine explosives, such as dynamite, gelignite, &c., would have been too quick in their action, and were discarded. Mr. Thomas Johnson, of Dudley, assisted by the shotfirers, conducted the experiments. The explosive selected was "tonite," which requires no thawing in cold weather. It was the principal blasting agent used on the Manchester Ship Canal, Severn Tunnel, Mersey Tunnel, Barry Docks, and many other large contracts. The one side of the hillock having been "peppered" with holes these were charged with 1 1/2 in. diameter 6oz. cartridges fitted with slow time fuses. These were lighted, and one after the other the whole of the charges exploded, simply lifting and toppling the stone and rubble down the hillside ready to be loaded up into trucks below, clearly demonstrating the slow action of the explosive. The experiments were, the *Birmingham Post* states, voted a thorough success.

THE sixth of the series of fortnightly lectures organised by the Glasgow Corporation on art subjects was delivered on Saturday evening, the lecturer being Mr. R. C. Graham, F.S.A., of Skipness, whose subject was "Notes on the Early Sculptures of Argyllshire." The chair was occupied by Bailie Shearer, chairman of the museums and galleries sub-committee. Mr. Graham referred to the well-known stones at Iona, and explained that they only form a portion of a very large collection, specimens of which still exist in most of the old Argyllshire churchyards. After showing what little interest was taken in this subject until about fifty years ago, the lecturer commented upon what had since been done by various writers in describing and illustrating a large number of specimens. Mr. Graham attributed the monuments to three

periods, showing in turn Celtic, Scandinavian, and Lombardic influence. A series of slides was exhibited, beginning with examples of pre-Norman sculptures, including the great standing crosses of Kildalton, of Kilmave, and St. Martin's cross at Iona. An example was next shown of a small class of stones of a Norwegian character. Then followed specimens attributed to the 13th, 14th, and 15th centuries, showing effigies of ecclesiastics and warriors, &c. Examples were also given of stones remarkable for the beauty or variety of their design. Views of many of the later crosses followed, and in describing a panel on the Kilchoman cross, the lecturer explained how plaited work was elaborated from a simple series of parallel bands, and to show how this was done reconstructed the one in question on the black board.

**MEETINGS FOR THE ENSUING WEEK.**

- MONDAY.—Royal Institute of British Architects. President's Address to Students. 8 p.m.  
 Surveyors' Institution. "Surveyors as Arbitrators," by A. A. Hudson. 8 p.m.  
 Liverpool Architectural Society. "Brass and Copper Work," by R. Ll. B. Rathbone.  
 Leeds and Yorkshire Architectural Society. "Ornamental Hand-Wrought Metalwork," by Nelson Dawson. 7.30 p.m.  
 TUESDAY.—Society of Arts. "Rennaissance Woodwork in England," by J. Hungerford Pollen. 8 p.m.  
 Auctioneers' Institute. Conversatione.  
 WEDNESDAY.—Society of Arts. "Fireproof Construction of Buildings," by Thomas Potter. 8 p.m.  
 THURSDAY.—Society of Architects. "Accounts for Architects," by Calder Marshall, F.C.A. St. James's Hall, Piccadilly, W. 8 p.m.

**The Society of Architects.**

Founded 1884. Incorporated 1893.

THE THIRD ORDINARY MEETING of the Society of Architects for the Session 1897-98 will be held at the Rooms of the Society, at St. James's Hall, Piccadilly, W., on THURSDAY, January 27th, 1898, at Eight p.m., when a Paper will be read by Mr. H. CALDER MARSHALL, F.C.A., entitled "ACCOUNTS FOR ARCHITECTS" by ELLIS MARSLAND, Hon. Sec. MONTAGU BALDWIN, M.A., Sec.

**Trade News.**

**WAGES MOVEMENTS.**

- BOLTON.—The plasterers of Bolton have just sent in an application for an advance in their wages by 1d. per hour and a reduction in their working hours from 52 to 49 1/2 per week in the summer. They are now rated at 9d. per hour, and ask for 10d. They also request to be allowed to start work half an hour later each summer morning except Monday.
- MANCHESTER.—As the result of an application by the members of the house painters' trade union in the Manchester district for an increase of wages, it has been agreed by the employers to make an advance of 1/2d. per hour above the present rate, to date from next May.
- LIVERPOOL.—At the town-hall, on Friday, the Lord Mayor (Alderman Houlding), sitting as arbitrator, took evidence regarding the points which are now in dispute in the plastering trade—namely, the apprentice rule, the country rule, and the time for giving notice of alteration of rules. There were present on behalf of the Liverpool Master Builders' Association Messrs. Thomas Jones, Charles Tanner, Ben H. Johnson, Robert Johnson, R. Bromley Gardner, J. Cothliffe, and J. A. S. Hassall (secretary); while the representatives of the National Association of Operative Plasterers in attendance were Messrs. W. W. Jackson, J. Griffin, W. Morgan, Richard King, J. Crute, John Kenny, and W. Baldwin (secretary). The award of the arbitrator will be delivered at the earliest date.

**PILKINGTON & CO.**

(ESTABLISHED 1833),

MONUMENT CHAMBERS,  
 KING WILLIAM STREET, LONDON, E.C.

Registered Trade Mark:

**POLONCEAU ASPHALTE**

Patent Asphalt and Felt Roofing.

ACID-RESISTING ASPHALTE.  
 WHITE SILICA PAVING.

SEYSEL ASPHALTE.

**LATEST PRICES.**

IRON, &c.		Per ton.	Per ton.
Rolled-Iron Joists, Belgian	.....	£6 0 0	to £6 10 0
Rolled-Steel Joists, English	.....	6 10 0	" 7 10 0
Wrought-Iron Girder Plates	.....	5 15 0	" 6 10 0
Bar Iron, good Staffs	.....	7 0 0	" 8 0 0
Do., Lowmoor, Flat, Round, or Square	.....	17 0 0	" 17 0 0
Do., Welsh	.....	5 15 0	" 5 17 6
Boiler Plates, Iron—			
South Staffs	.....	7 17 6	" 8 5 0
Best Suedhill	.....	10 0 0	" 10 10 0
Angles 10s., Tees 20s.	per ton extra.		
Builders' Hoop Iron, for bonding, &c.	£6 15s. 0d. per ton.		
Builders' Hoop Iron, galvanised	£15 10s. 0d. per ton.		
Galvanised Corrugated Sheet Iron—			
No. 18 to 20.	Per ton.	No. 22 to 24.	Per ton.
6ft. gauge	£10 15 0	11 10 0	11 10 0
Best ditto	11 5 0	11 10 0	11 10 0
Cast-Iron Columns	.....	£6 0 0	to £9 10 0
Cast-Iron Stanchions	.....	6 0 0	" 8 10 0
Cast-Iron Sash Weights	.....	—	" 4 2 6
Cast-Iron Socket Pipes—			
3in. diameter	.....	5 10 0	" 5 15 0
4in. to 6in.	.....	5 5 0	" 5 10 0
7in. to 24in. (all sizes)	.....	4 15 0	" 5 5 0
[Coated with composition, 2s. 6d. per ton extra; turned and bored joints, 5s. per ton extra.]			
Pig Iron—			
Cold Blast, Lilleshall	.....	105s. to 110s.	
Hot Blast, ditto	.....	57s. 6d. to 62s. 6d.	
Wrought-Iron Tubes—Discount off Standard Lists f.o.b.			
Gas-Tubes	.....	75p.c. Fittings	77p.c.
Water-Tubes	.....	70	" 72 1/2
Steam-Tubes	.....	62 1/2	" 65
Galvanised Gas-Tubes	.....	60	" 62 1/2
Galvanised Water-Tubes	.....	55	" 57 1/2
Galvanised Steam-Tubes	.....	45	" 47 1/2
Sheet Zinc, for roofing and working up	.....	£22 10 0	to £23 10 0
Sheet Lead, 3lb. per sq. ft. super.	.....	15 0 0	" 15 10 0
Pig Lead, in lewt. pigs	.....	13 15 0	" 14 15 0
Lead Shot, in 28lb. bags	.....	17 10 0	" 18 10 0
Copper Sheets, sheathing and rods	.....	53 10 0	" 59 10 0
Copper, British Cake and Ingots	.....	50 10 0	" 51 10 0
Tin, Straits	.....	64 3 9	" 65 3 9
Do., English Ingots	.....	67 10 0	" 68 0 0
Spelter, Silesian	.....	17 7 6	" 18 7 6
Cut Clasp Nails, 3in. to 6in.	.....	£8 15 0	" £9 15 0
Cut Floor Brads	.....	8 10 0	" 9 10 0
Wire Nails (Points de Paris)			
0 to 7	8	9	10
8 to 11	12	13	14
12 to 15	15	16	17
16 to 19	18	19	20
20 to 24	21	22	23
24 to 28	24	25	26
28 to 32	27	28	29
32 to 36	30	31	32
36 to 40	33	34	35
40 to 44	36	37	38
44 to 48	39	40	41
48 to 52	42	43	44
52 to 56	45	46	47
56 to 60	48	49	50
60 to 64	51	52	53
64 to 68	54	55	56
68 to 72	57	58	59
72 to 76	60	61	62
76 to 80	63	64	65
80 to 84	66	67	68
84 to 88	69	70	71
88 to 92	72	73	74
92 to 96	75	76	77
96 to 100	78	79	80
100 to 104	81	82	83
104 to 108	84	85	86
108 to 112	87	88	89
112 to 116	90	91	92
116 to 120	93	94	95
120 to 124	96	97	98
124 to 128	99	100	101
128 to 132	102	103	104
132 to 136	105	106	107
136 to 140	108	109	110
140 to 144	111	112	113
144 to 148	114	115	116
148 to 152	117	118	119
152 to 156	120	121	122
156 to 160	123	124	125
160 to 164	126	127	128
164 to 168	129	130	131
168 to 172	132	133	134
172 to 176	135	136	137
176 to 180	138	139	140
180 to 184	141	142	143
184 to 188	144	145	146
188 to 192	147	148	149
192 to 196	150	151	152
196 to 200	153	154	155
200 to 204	156	157	158
204 to 208	159	160	161
208 to 212	162	163	164
212 to 216	165	166	167
216 to 220	168	169	170
220 to 224	171	172	173
224 to 228	174	175	176
228 to 232	177	178	179
232 to 236	180	181	182
236 to 240	183	184	185
240 to 244	186	187	188
244 to 248	189	190	191
248 to 252	192	193	194
252 to 256	195	196	197
256 to 260	198	199	200
260 to 264	201	202	203
264 to 268	204	205	206
268 to 272	207	208	209
272 to 276	210	211	212
276 to 280	213	214	215
280 to 284	216	217	218
284 to 288	219	220	221
288 to 292	222	223	224
292 to 296	225	226	227
296 to 300	228	229	230
300 to 304	231	232	233
304 to 308	234	235	236
308 to 312	237	238	239
312 to 316	240	241	242
316 to 320	243	244	245
320 to 324	246	247	248
324 to 328	249	250	251
328 to 332	252	253	254
332 to 336	255	256	257
336 to 340	258	259	260
340 to 344	261	262	263
344 to 348	264	265	266
348 to 352	267	268	269
352 to 356	270	271	272
356 to 360	273	274	275
360 to 364	276	277	278
364 to 368	279	280	281
368 to 372	282	283	284
372 to 376	285	286	287
376 to 380	288	289	290
380 to 384	291	292	293
384 to 388	294	295	296
388 to 392	297	298	299
392 to 396	300	301	302
396 to 400	303	304	305
400 to 404	306	307	308
404 to 408	309	310	311
408 to 412	312	313	314
412 to 416	315	316	317
416 to 420	318	319	320
420 to 424	321	322	323
424 to 428	324	325	326
428 to 432	327	328	329
432 to 436	330	331	332
436 to 440	333	334	335
440 to 444	336	337	338
444 to 448	339	340	341
448 to 452	342	343	344
452 to 456	345	346	347
456 to 460	348	349	350
460 to 464	351	352	353
464 to 468	354	355	356
468 to 472	357	358	359
472 to 476	360	361	362
476 to 480	363	364	365
480 to 484	366	367	368
484 to 488	369	370	371
488 to 492	372	373	374
492 to 496	375	376	377
496 to 500	378	379	380
500 to 504	381	382	383
504 to 508	384	385	386
508 to 512	387	388	389
512 to 516	390	391	392
516 to 520	393	394	395
520 to 524	396	397	398
524 to 528	399	400	401
528 to 532	402	403	404
532 to 536	405	406	407
536 to 540	408	409	410
540 to 544	411	412	413
544 to 548	414	415	416
548 to 552	417	418	419
552 to 556	420	421	422
556 to 560	423	424	425
560 to 564	426	427	428
564 to 568	429	430	431
568 to 572	432	433	434
572 to 576	435	436	437
576 to 580	438		

LIST OF COMPETITIONS OPEN.

Carlton, Victoria—Children's Hospital	£100, £50, £25	J. Nicholson, Hon. Sec., Pelham-street, Carlton, Australia	Jan. 30
Leicester—Motor Refuse Carts	Corporation	E. G. Mawbey, Borough Engineer, Leicester	31
Rugby—Public Work, Cattle Market		T. M. Wralshaw, Clerk, Rugby	Feb. 1
Eastleigh—Public Offices	50zs. (merged), 20gs.	Hy. White, Clerk, U.D.C., 19, St. Peter's-street, Winchester	7
Wolverhampton—Motor Vans	Public Works Committee	J. W. Bradley, C.E., Borough Engineer, Town Hall, Wolverhampton	7
Barrow-in-Furness—Technical Schools	£50 (merged), £20	The Town Clerk, Town Hall, Barrow-in-Furness	14
Port Elizabeth—Free Library (Assessors, Sir F. Blaine and R. H. Hammersley-Hunan—£22,000 limit)	100 Guineas, 50 Guineas	G. Oettle, Librarian, Port Elizabeth, S.A.	15
New York—Sun Dial (Plaster Model)	500dol., 250dol.	Sec. National Sculpture Soc., 215, West 57th-street, New York	28
Newcastle-on-Tyne—New Infirmary (Local Architects)	(No first) £150, £100, £50	Secretary Building Committee, Newcastle	Mar. 1
Berwick-on-Tweed—Police-Station (£6,000 limit)	£200, £100	R. Weddell, Town Clerk, Berwick-on-Tweed	14
Singapore—Town Hall (300,000dol. limit)	£200, £100	Major Cameron, R.E., Colonial Offices, Downing-street, S.W.	31
Belper—Sewage Disposal Schemes	50 Guineas, 25 Guineas	Joseph Fynn, Clerk, Belper	May 1

LIST OF TENDERS OPEN.

BUILDINGS.

Halifax—Extension of Atlas Boiler Works	Managers	Geo. Buckley and Son, Architect, Town Chambers, Halifax	Jan. 22
Wickham Market—Additions to Schools	Magistrates and Council	Henry J. Wright, 4, Museum-street, Ipswich	22
Flushing, Cornwall—School Buildings	Guardians	F. F. Savage, Flushing Vicarage	22
Leith—Electric Light Station, Great Junction-street	Gas Commissioners	T. B. Laing, Town Clerk, Leith	22
Frizington—Alterations to Cottages, Moor-street		J. W. Drummond, Sec., Permanent Benefit Bldg. Soc., Cockermouth	22
Macroom—Drying-Chamber and Bath-Room at Workhouse		J. T. Murphy, Clerk, Macroom, Ireland	22
Long Lawford—House		T. W. Willard, Architect, Rugby	22
Perth—New Gasworks, Friarton		Wm. MacLeish, Clerk, City Chambers, Perth	22
Milton Buckland—Tea-Room		Rev. J. W. Simpson, Wesleyan Minister, Tavistock	22
Sheffield—Machine Shop		Edward Winder, jun., Architect, Wharfedale, Sheffield	22
Rainham, Kent—Two Houses		T. S. Wakeley, The Chestnuts, Rainham, Kent	22
Bournemouth—Additions to Glenbrook		D. Stewart, Architect, Richmond Chambers, Bournemouth	22
Boat of Garten—Villa		D. Macpherson, Boat of Garten	22
Rawdon—Alterations and Additions to Friends' School		Jackson and Priestman, The Exchange, Bradford	22
Guesting—Police Buildings		East Sussex County Council	22
Lochmaben—Alterations to Free Church		Henry Card, County Surveyor, County Hall, Lewes	22
Cork—Two Dwelling-Houses, Blair's Hill		T. E. Watson, National Bank, Lochmaben	22
Fairburn—Additions to School Board		School Board	22
Lockwood—Railway Waggon Works		James F. M'Mullen, M.S.A., Architect, 30, South Mall, Cork	22
Cullingworth—Thirteen Houses		A. Hardley, Architect and Surveyor, Carlton Chambers, Castleford	22
Epsom—Temporary Structures (for 700 patients and staff)		James Kenworthy and Son, Lockwood, York	22
Horton Manor Es'tate		David Weatherhead, Architect, 55, Devonshire-street, Keighley	22
Bristol—Infant School, Hotwells	London County Council	R. W. Partridge, Clerk Asylums Committee, 21, Whitehall-pl., S.W.	24
Godalming—Mortuary in Cemetery	Bristol School Board	William Avery Adams, Clerk, Guildhall, Bristol	24
Leeds—Eight Houses	Joint Burial Board	Welman and Street, Architects, Church-street, Godalming	24
Slathwaite—Residence, Lingards	Industrial Co-operative Society	W. S. Braithwaite, Architect, 6, South-parade, Leeds	24
Robin Hood—Rebuilding Old Half-Way House Hotel	City Brewery Company	J. Berry, Architect, 9, Queen-street, Huddersfield	24
Bristol—Premises, Wine-street	Harris and Sons	Thomas Winn, Architect, 90, Albion-street, Leeds	24
Chelmsford—Villas and Cottage, New London-road	Dr. Thresh	Henry Williams, Architect, 24, Clare-street, Bristol	24
Swindon—Washing Baths	G.W.R. Medical Fund Society	George E. Clare, Architect, 66, Duke-street, Chelmsford	24
Bristol—Repairing Public Baths	Corporation	The Secretary, Swindon	24
Llanwrst—School for Girls, and Alterations and Additions to Boys' Schools, at Llanwrst County School		T. H. Yabbcorn, City Engineer, 51, Prince-street, Bristol	24
Manchester—Thirty-two Two-Story Tenement Buildings, &c.	Sanitary Committee	Peter McIntyre, Clerk to the Governors, Llanwrst	25
Bideford—Kingsley Hotel, High-street	Commissioners of H.M. Works	The City Surveyor, Town Hall, Manchester	25
Winchester—Enlargement of Post Office	Corporation	R. T. Hookway, Architect, 12, Bridgeland-street, Bideford	25
Elton—Inn	Lancashire and Yorkshire Ry. Co.	Hon. Reginald B. Brett, Secretary, 12, Whitehall-place, S.W.	25
Bootle—Lodge, Derby Park	Captain F. T. Verschoye	Edw. A. Whipham, A.R.I.B.A., 59, High-street, Stockton-on-Tees	25
Batley—Eight Houses, George-street	Sanitary Committee	J. H. Farmer, Town Clerk, Bootle	25
Hoghton—Passenger Station and Footbridge	Markets Committee	B. Wilson, Architect, Bradford-road, Batley	25
Burley, Leeds—Sixteen Houses, Cardigan-lane	London County Council	C. W. Bayley, Secretary, Hunt's Bank, Manchester	25
Cashelshanagan—Villa	Sanitary Committee	C. F. Wilkinson, 35, Park-square, Leeds	25
Manchester—Thirteen Shops, Oldham-road	School Board	William Barker, Architect, 3, Richmond-street, Londonderry	25
Burnley—Extension of Electric Light Station	Sanitary Committee	The City Surveyor, Town Hall, Manchester	25
Manchester—Twenty-six Three-story Tenements and Two Shops, Pott-street, Ancoats	Sanitary Committee	G. H. Pickles, A.M.I.C.E., Town Hall, Burnley	25
Leeds—Dead Meat Market, New York-street	Sanitary Committee	The City Surveyor, Town Hall, Manchester	25
Lightcliffe—Stable and Coach-House, Lightcliffe	Markets Committee	Jno. Harrison, Town Clerk, Town Hall, Leeds	25
Bethnal Green, E.—Block of Dwellings on Boundary-st. Area	London County Council	Joseph F. Walsh, Architect, Bank Chambers, Halifax	25
Manchester—Thirty-six Two-Story Tenement Buildings	Sanitary Committee	T. Bell, Clerk, Council Offices, Spring-gardens, S.W.	25
Milford—Gate Lodge and Entrance at Cemetery	School Board	The City Surveyor, Town Hall, Manchester	25
Leeds—Repairs to Various Schools	Sanitary Committee	J. J. Phillips and Son, Architects, 61, Royal-avenue, Belfast	25
Manchester—Lodging-House, Harrison-street, Ancoats	School Board	W. Packer, Clerk, School Board Offices, Leeds	25
Keighley—Two Shops and Houses, Cooke-street	Sanitary Committee	The City Surveyor, Town Hall, Manchester	25
Hastings—Additions to Olive Vale School	School Board	W. and J. B. Bailey, Architects, 1, Scott-street, Keighley	26
Deesbury—Five Houses in Thornhill-road	Directors of the People's Palace	J. H. Tendall, Clerk, 4, Bank Buildings, Hastings	26
Bridlington Quay—Eleven Houses	Highland Railway Co.	H. H. Brearley, Architect, Hanover-street, Batley	26
Hull—New School Board Offices, Albion-street	Corporation	W. S. Walker, Architect, Central Chambers, Bridlington Quay	26
Aviemore Junction—Station Buildings	Guardians of Holborn Union	D. Jno. O'Donoghue, Clerk, Town Hall, Hull	26
Caton—Dwelling-House	Alfred Jernyn	Wm. Gowenlock, Secretary, Inverness	26
Middlesbrough—Cannon-street Police Station	J. W. and W. W. Walker	C. Leeson, Caton, near Lancaster	26
Mitcham—Visitors' Room and Engineer's House at Schools	School Board	Borough Engineer, Municipal Buildings, Middlesbrough	26
Ovenden—Two Semi-Detached Villas	Guardians	C. E. Vaughan, F.R.I.B.A., 25, Lowther Arcade, Strand, W.C.	26
King's Lynn—Shops, Paradise-road	Alfred Jernyn	Medley Hall, Architect, 29, Northgate, Halifax	26
Newbury—Additions to General Supply Stores	J. W. and W. W. Walker	Wm. Jarvis, Architect, Market-square, King's Lynn	27
Kidderminster—Rebuilding the Out-Offices, Hume-st. Schools	School Board	Samuel C. Johns, M.S.A., Architect, Wallingford	27
Bristolington—Additions to Schools	Guardians of Bromley Union	W. M. Roden, Clerk, St. Mary's-street, Kidderminster	27
Farnborough—Extension of Workhouse Infirmary	Corporation	W. V. Gough, Architect, 24, Bridge-street, Bristol	27
Bath—Terrace, Newmarket-row	Guardians	R. Gordon Mullen, Clerk, 96, High-street, Bromley	27
Stockport—Workhouse, Stepping Hill	Austin Longley	Chas. E. Davis, F.S.A., City Architect, Bath	27
Hebden Bridge—Forty-Eight Houses, Birchcliffe Estate	Billericay Rural District Council	Charles F. Johnson, Clerk, Union Offices, Shaw Heath, Stockport	27
East Ardsley—Two Through Houses	Metcalfe and Bradshaw	Sutcliffe and Sutcliffe, Architects, Todmorden	28
Morecambe—Front and Fittings to Bank Premises	John Kelleher	Buttery and Birds, Architects, Queen-street, Morley	28
Great Burnstead—Repairs to White Bridge	Mrs. Brook	Jas. Marshall, Architect, Back-crescent, Morecambe	29
Morley—Bakery and Stables, Fountain-street	Corporation	C. Edgar Lewis, Clerk, Brentwood	29
Pudsey—Sunday School	John Kelleher	Buttery and Birds, Architects, Morley	29
Cork—Nine Houses, College-road	Mrs. Brook	Hodgson and Farrar, Architects, Old Bank Chambers, Bradford	29
Pontefract—Shop Front, Beast Fair	Corporation	W. H. Hill and Son, Architects, 28, South Mall, Cork	29
Wolverhampton—Shelter, East Park	Whytehouse Estates Co.	Tennant and Bagley, Architects and Surveyors, Pontefract	29
Kirkcaldy—Six Shops and Fifteen Dwelling-Houses, Whytehouse Mansions	Shoreditch Vestry	J. W. Bradley, Board Engineer, Wolverhampton	29
Shoreditch—Transformer Sub-Station, Worship-street	London County Council	Robert Little, Architect, 4, St. Brycedale-avenue, Kirkcaldy	31
Londonderry—Three Houses, Nortland-road	School Board	H. Mansfield Robinson, Vestry Clerk, Town Hall, Old-street, E.C.	31
Crown—Additions to Schools	London County Council	Wm. Barker, Architect, 3, Richmond-street, Londonderry	31
Tooting Common—Refreshment House	County School Managers	Rollinson and Son, Architects, 3, Corporation-street, Chesterfield	31
Cork—Pair of Semi-Detached Villas	School Board	T. Bell, Clerk, Council Offices, Spring-gardens, S.W.	31
Tregaron—Intermediate School	London County Council	W. H. Hill and Son, Architects, 28, South Mall, Cork	31
East Ham—Schools (for 645 Children), White Horse-lane	Improvement Committee	M. Morgan, Clerk, Tregaron	31
Camberwell—Refreshment House, Myatt's Fields	Corporation	W. J. Brett, Clerk, Lichfield-terrace, Upton Park, E.	31
Glasgow—Steward's House, Lodges, Entrance Gateway, Water Tower, Storage Tanks, & Boundary Walls, Ruchill Hospital	Corporation	T. Bell, Clerk, Council Offices, Spring-gardens, S.W.	31
Manchester—Twenty-Six Cottages at Miles Platting	Improvement Committee	John Lindsay, Interim Clerk, City Chambers, Glasgow	Feb. 1
Southampton—Isolation Hospital, Mousehole-lane, Millbrook	Corporation	City Surveyor, Town Hall, Manchester	1
Bourne—Cattle Market	Warwick and Richardson	George B. Nalder, Town Clerk, Municipal Offices, Southampton	1
Paignton—New Buildings	Gas Company	F. G. Shilcock, Architect, West-street, Bourne, Lincs	1
Tullyallen—New Church	Rev. Thomas Taafe, P.P.	F. W. Puddicombe, Secretary, 5, Victoria-street, Paignton	1
		William H. Byrne, M.R.I.A., Architect, 21, Suffolk-street, Dublin	1

# THE BUILDING NEWS

## AND ENGINEERING JOURNAL.

VOL. LXXIV.—No. 2247.

FRIDAY, JANUARY 23, 1898.

### INSTRUCTIONS TO ARCHITECTS.

**A**UTHORITY in matters of building is not recognised. Many people fancy they can order what they like, and in their own way; that it is easy to make a building of any shape and style they please. Conditions of life, of social surroundings, of site, and climate are things of no account to such people;—all they have to do is to give instructions as they would for a dress or a coat, and then expect a fitting and agreeable garment. It is hard to convince some people that what they order will not answer—in short, that their own ideas will not give the result they anticipate from them. The ordinary client is so inclined to take his ideas from what others have done—to imagine that because Mr. A's house in the country is so commodious and pleasant, the same results will follow in a town suburb. Because a particular disposition of rooms or offices is suitable in one place, it does not follow that it will suit in another locality where the site is different, the aspects of windows changed, or the requirements not the same. With style and decoration, it is precisely the same. Not everyone can decide for himself whether Greek, or Italian, or Georgian, or any other modern style is best for his purpose, as the question depends entirely on plan and position. Second-hand ideas here also prevail; it is fashionable, or *chic*, or what not to affect a particular period of craze, and the architect is forced to comply with the client's taste. Now, all this confusion and ignorance on questions of architecture or building arise from the non-recognition of authority in those who practise the art, and because, instead of facts and definite principles, the average employer of architects thinks he can substitute his own whims.

Instructions given to a lawyer are generally precise statements of events; they are facts as far as they are known to the client. But the instructions the architect receives are often conditional on other things; in other words, the client says: "I want a building of such and such a kind, to accommodate a certain number of people, but I leave you to satisfy me with the result." In the ordinary competition it takes this form: "Certain instructions must be strictly obeyed, but their compliance will not be deemed sufficient for the award of a prize;" in other words, the author must use his own discretion or "give us something better if he can." Many recent competitions have confirmed this assumption. The architect has closely adhered to the programme; he has followed the dimensions and requirements of the leading departments; he has kept within the limit of cost; but his design has failed to gain acceptance. Another author, whose plan shows several departures from the instructions, succeeds in winning the first premium, even although an assessor has been appointed to examine the designs and report on the fulfilment of the conditions. Everybody is surprised at the result; those who have carefully observed the instructions express their astonishment and anger, the rest of the competitors are indignant, and the promoters are scandalised. One of two things is obvious: either the instructions issued to competitors were ignorantly framed, or the assessor has shown his incompetence, or strangely overlooked his duties as a referee. More often than not the committee or their official have blundered; they have drawn up conditions that are either impracticable or

defective. They have required something to be done which is physically impossible within the boundaries of site, a department or set of rooms to be placed on the ground floor when there is no room for them; or they have not considered the difficulty of lighting, or the requirements of some local authority. It is a hard case for the compliant competitor who has obeyed instructions, and the only just course for the committee to take is to admit their mistake, and compensate the most deserving, or award the premiums, and then ask a select few to compete again. But the course generally pursued is to stifle their errors, and award the author who has had the courage to use his better judgment by overthrowing the conditions. Of course, competitors naturally protest against a treatment which breaks the compact and gives the prize to the man who sets the instructions at defiance. It seems unfair. At the same time, a broader view of the issues appears more desirable than servile adherence to instructions that are imperfect or defective. Let us take the practical example of a man who seeks for professional advice of his doctor or lawyer. He gives instructions, but he does not bind his adviser down to follow them implicitly: to do so would be to deprive himself of the skill and experience of their profession; nor would a client be so unreasonable as to require his architect to follow closely to instructions—he desires the best plan or design he can obtain. So with the promoters of a competition: they advertise for the best interpretation of their requirements, and it is absurd to expect them to be bound hand and foot by their own conditions, if by so doing they deprive themselves of a better design. There will always be men who interpret *literally*, others who follow only the *spirit* of the instructions—in other words, followers of the *letter* and of the *spirit*. It is for the architect, as a responsible agent, to be guided by principle rather than be fettered by rules and instructions, even if, haply, thereby the weak suffer in the contest.

This view does not apply, of course, to certain instructions, such as those relating to lines of frontage, "ancient lights," or technical by-laws. The architect who ignores the frontage lines by trespassing beyond them, who obscures some neighbouring windows, or who does something contrary to the local by-laws, commits a breach of the contract which places him outside. On the other hand, any instructions which concern the arrangement or location of rooms or design ought not to have the force of obligation, as they are matters within the architect's special functions, and it would always be wiser if building committees and promoters only threw them out as suggestions to be followed or not, as the author saw fit. We think all our leading competitors adopt this distinction between those things which are obligatory and binding and those that are recommendatory only. In other words, we have a case of essentials and non-essentials. Much friction and misunderstanding would be saved if architects made it clear to clients and committees what the effect of certain instructions is, or, on the other hand, if the latter simply stated what were really essential points, and left the architect freedom to act as he saw fit. Take the plan of a building for a public purpose. It is perfectly impossible for a designer to say beforehand whether the conditions imposed by his employer can be carried out. Not until the disposal of the chief rooms or offices on the given site, when walls and areas are drawn to scale, can the architect determine whether a condition is practicable or not. A certain department is to be placed on the ground floor, but it is found impossible to comply, on account of room, and the author locates it on the next floor. If he shows a better arrangement of hall and corridors by so doing, there is no valid reason why this departure

should disqualify. Or something may transpire which calls for modification of the instructions, as in the requirements of a public department, a legal question of right of light, convenience of client, &c. Individual interpretation, too, will vary. One man takes an instruction in a literal sense, another in a general sense. What A thinks absolutely important, B may consider only of secondary account. Each man reflects the truth in his own way, and so it is that we find so many diverse constructions put upon seemingly simple instructions; so many different designs for one object. It is to select the best of them that we invite several architects to compete, for if an architectural design could be worked out like a mathematical problem, from certain data or terms, and the solution was the same in every case, there would be no need of competition—one qualified architect would do as well as another.

Less determinate matters of an artistic kind, although resting on principles, are often left alone by the client; but he has the provoking habit of discounting the taste of his architect, and taking the opinion of decorators and painters. He does not trouble so much about them, because he likes his friends to think he is not behind other people in these matters, and he is afraid to give instructions. Those are in a hopeless case who interfere, who have the audacity to decide on the designs and colours and shades of wall and ceiling decoration, or who think they are quite as competent as the architect to select their own style and to choose their own elevation. Is the architect to submit to such dictation, or what? A man who throws aside all authority and adopts his own political or religious creed does little harm to anybody else, for he has only himself to please; but a man who repudiates the education and professional authority of his architect, and defies the simplest elements of form, or of colour, or of style, does more harm, not only making himself ridiculous, but perpetrating a monstrosity or an eyesore for those who come after him. He is injuring himself and others, disseminating a pernicious taste, which, like a pernicious literature, is destructive to all purity and honesty of thought, not only of his own, but other generations. Who is to lead? The Church or the political organisation can excommunicate or cast off the so-called member who disobeys or ignores the principles of its society, and be rid of him; but the erring or schismatic builder who insists upon having his own way, or the perpetrator of a hideous structure or an artistic outrage, is free to perpetuate his monstrosities, and degrade the taste of the people. His work remains as a reproach to the age, and his influence lives after him.

### BUILDING NOMENCLATURE.

**V**AGUENESS of definition is one of the many obstacles in the way of the instruction of the young architect—we mean of sundry terms which practical men are in the habit of using to define certain materials and modes of construction, but which remain unintelligible to the student. The practical requirements of the architect and builder demand certain trade terms and phrases which are known to all those who write specifications, and their usage in this way has made it the more difficult to substitute other and more correct names. To take a few of these. The nomenclature of the bricklayer is not without pitfalls for the unwary. It takes some time for a novice to master the qualities of the various sorts of bricks—"clamps," "firsts" and "seconds" grey stocks, "place" bricks, "malms" of different qualities, kiln-burnt bricks. Now, some of these names explain themselves, like bricks burnt in kilns or clamps; but it is rather bewildering for the learner to have to

know the differences between "place" bricks, those which are not well burned, and those well burned, or "stocks." Then there are different sorts of malms, each having some name, like "facing pavours," "common stocks," &c. It would be more convenient to distinguish the qualities of each class by "first," "second," "third," or by some letter, A, B, C quality, than to give them different names which are not always clear. The mode of burning or manufacture ought certainly to suggest the generic name, and some distinguishing adjective or letter appended to determine its quality. But if we take up half a dozen specifications, we shall find as many different names given to the same brick, much to the confusion of the young architect who has not specially learned this particular trade. He wants, perhaps, to use the best stocks, the London "malm stock," but is not sure of the right name to describe it. One calls it "facing pavour"; another simply "malm." Colour is essential to him perhaps: he wants a bright yellow-coloured brick, or a stone-coloured brick. The practical builder would know at once that the London malm is the right description for the first kind and the Suffolk for the lighter hue. If the architect wishes to specify the right kind of brick for arches and dressings of uniform colour and texture, he may not be always sure to obtain it by some of the names used; or he may desire to specify the brick to be used for the chief fronts of his building. By using such a term as "best stocks," the evasive contractor may introduce a very different kind to that intended for each case. The terms "firsts" or "cutters" for the arches, &c., and "seconds" for the fronts generally, ought to indicate the sort to be used in each case; but these qualifying terms are not always used. There is equal confusion in the names adopted for red work, cutters and stocks being indifferently used. All this is attributable to the great diversity of terms. As there are only clamp and kiln-burnt bricks, and there are three kinds of clamps recognised according to their fitness and quality for cutters, facing interior walling, paving, &c., it would be easy to distinguish them by some definite name or number.

And it is so with other materials. Take timber. A correspondent, Mr. D. Forbes Smith, has very opportunely called attention to the very loose and indefinite meaning attached to the terms "red" and "yellow" deal, or the difference between them from the same tree. If there is no difference between them, "Why," he pertinently asks, "is the term 'yellow' deal almost exclusively applied to floor-boards? Why, again, is the term deal used in specifications instead of pine? Why the several names 'fir,' 'pine,' and 'deal' are used, when they are from the same tree, and how they can be distinguished by two colours, are puzzling at least to the student, if not to practical men. Mr. Stevenson's useful explanation is not generally known to either class, though, as he shows, the term "deal" implies a converted piece of wood or portion of a tree. As to the dual signification "yellow" and "red" applied to it, the explanation accounts for the terms, but is not satisfactory. As Mr. Stevenson says, these trade terms are an inheritance of the past and are not easily set aside, a reason which applies to other terms. Unfortunately for learners, the textbooks do not help them, as these explanations are not given.

Then there is some confusion in the nomenclature of masonry. How often are the terms misapplied. Every locality has its own special names for certain kinds of masonry. Look at the difference in the meaning applied to "ashlar." Squared stone masonry and ashlar are the same practically, but a difference lies in the closeness of the jointing. Then, the terms "pitched-faced," "range work," the different sorts of rubble

walling, are used in specifications without any very exact meaning. All students of stonework are acquainted with particular local names, as well as methods of measuring. On the whole, the classification of masonry terms is far from being satisfactory. Much, too, is wanted to simplify the nomenclature of building stones. The geological basis, of course, affords an important means of distinguishing between them; but the ordinary terms current are chiefly derived from the names of quarries or localities. Thus, under Bath stone, there are many varieties distinguished by certain qualities of hardness, texture, and colour, but named from the quarry. It seems desirable to classify, first, according to either geological formation or mineralogical character, and then as to texture, and colour. It is very bewildering to find there are two or more names given to the same kind of stone. As in timber and other materials, the names used have become associated with trade, and it is not very easy to introduce a simpler classification. In the matter of slates, much ambiguity exists. Many architects specify Bangor slates without any definite knowledge of the sizes. In the North of England, slates 16 by 10 are often specified, while in the South 20 by 10 and larger are asked for. Again, in specifying Westmoreland slates, which are of several sizes, architects are not sure of the kind they want. Then the terms "best" and "seconds" are exceedingly ambiguous; so are the names red, blue, or grey slates. What does the adjective "best" mean—thin, thick, or from what quarry? The word indeed is not definite, if it does not state the particular quarry or other quality, such as straightness, uniform cleavage thickness, freedom from spots, &c. So in other trades there is much uncertainty in the nomenclature used. Names and terms are employed which are not exact, and may mean diverse things to different tradesmen. There are many ambiguities in plumbing, and the terms employed do not always convey a definite meaning. Other ambiguous terms will occur to all our readers. The classification of building terms, whether relating to materials or technical qualities, is by no means so easy or scientific as it ought to be, and there is a redundancy of terms and phrases which do not convey any definite or important difference. A good dictionary of building nomenclature, based on a scientific classification, is a want of the profession and of the age.

#### ROYAL INSTITUTE OF BRITISH ARCHITECTS.

THE sixth ordinary meeting of the Institute for the present session was held on Monday evening. The president, Professor George Aitchison, R.A., occupied the chair, and delivered the annual

#### ADDRESS TO STUDENTS.

He remarked that he had the welfare of the students very much at heart, not only because he saw how many of his own youthful days were wasted from having no proper direction, but also because it was the one feature in all architectural epochs over which the elders could have the greatest influence. At present they knew not how to produce genius, nor how to turn the public mind to desire and take an interest in noble architecture. Symbolism had been abolished, so that the bulk of buildings did not tell their tale, and the public were ignorant of what was being done for them. If any statesman knew his business, every good sculptor in the kingdom would be fully employed in sculpturing buildings to tell the poor what was done for them: how they were taught, cured, looked after in their old age, and in their sickness and infirmities, and how law and order, peace and industry, were being taught to the savages who surrounded our Empire. It was in the interests of the students and the art that he had proposed to omit from the examinations all that was not purely architectural, for this now shut out those who had not received a good general schooling. They did not want to shut

out a genius, nor even a resolute and determined worker, because he had not learnt Greek, Latin, French, or German. He did not suppose Raffaele had much schooling when he was taught to draw at three years old, and yet he not only became the greatest painter of modern times, but a sculptor and an architect too. They were not surprised that a man with such inventive genius as Raffaele should have become skilful as an architectural designer when he had learnt the elements of architecture; but it was surprising that he should have been one of the great constructors of his age, for Bramante on his death-bed recommended him for the post of head architect to St. Peter's. He did not suppose that Palladio had much schooling when he was but a mason's boy, nor our own Ware when he was a chimney-sweep. The president added that he devoted twenty years in trying to gain an insight into the

#### CAUSES OF THE GREAT ARCHITECTURAL EPOCHS

of Europe, and this was the conclusion he had come to. They seemed to him to result from the set of the public mind towards enriching its age with monuments which embody the general aspirations. To accomplish this there must be hoarded wealth, noble desires, and architectural judgment. There must be, too, those endowed with the genius to express those aspirations architecturally, and highly skilled craftsmen to carry them out. Genius was the power of invention, and was mostly accomplished by that general capacity we called talent. This heavenly gift of genius and this general capacity were, however, only the raw material which had to be worked up. Genius had not only to learn what was necessary to express its conceptions, but to strive to do its best. Architecture was a structural art; and, therefore, the art of construction was the most necessary thing to be known. The science of construction was statics; consequently the elements of statics needed to be known. A knowledge of statics, too, gave us a true ratio between every part of a structure, and it gave the real shape that each part must take; if we were as clever as nature, it would in all probability give us a beautiful shape. Unfortunately, we were far from being so clever, and consequently we had to learn by other means how a beautiful shape can be made out of the necessary shape. For this purpose we must study deceased architecture and nature. Every piece of deceased architecture that we admired could be made to show us the æsthetic laws that governed it and produced its excellence, and these laws were as capable of being employed now as then. Every important portion of an ancient building might have the reason extorted from it as to why it pleased at its creation and pleased us now; but from our greater knowledge, and from the necessity of using other materials, we might see that the proportions then used are not now applicable; for instance, a Greek Doric column showed the statical knowledge of its day, but it certainly did not now. Our materials and climate were different; the emotion now wanted was probably different, and the æsthetic sentiment of our day was probably different too; so we had to get some of our hints and solutions from nature's works. Without the gifts of the mathematical and the artistic capacities, no man should become an architect; but there was another requirement, which we called planning—that was, how to make each room, hall, passage, and staircase answer its purpose, and how to pack them in the most convenient way. This might be called common planning; but there was artistic planning as well, which was the choice of forms which were not only appropriate for use, but were agreeable to the eye. He would by no means discourage anyone who loved architecture and would study it from being an architect, for there were various degrees of power and excellence in architectural works, all of which made up the realm of architecture. The smallest cottage, if properly arranged, perfectly constructed, and perfectly proportioned, might be as delightful to contemplate as the mansion, the palace, the town-hall, or the cathedral, though it did not require the same knowledge, the same daring, and the same invention. Nothing great was reached in fine arts without simplicity, but lovely simplicity was reached by great labour, and took about ten times as long to arrive at as ornateness. Just now there was a great inclination to get effects by exaggeration, or by ways that involved little thought or trouble, such as by the distortion of the Orders,

the sticking on bits of rustication all over a building, or by putting water-gates into the attics of buildings. They should not forget the proverb that "the human mind was greedy of novelty," so much deplored by William Morris and by Mr. Ruskin, though the desire for novelty was natural to man, and could not be overlooked or overcome, for each generation had not the same knowledge or desires as the preceding one. Let them, instead of deploring the taste for novelty, echo Tennyson's words:—"Let the great world spin for ever down the ringing grooves of change." True novelty was obtained by development. They saw how Nature developed her types, and if they had lived in the palmy days of Greece, they would have seen how the young clodhopper was developed into grace and beauty by training. It was rather nauseous and rather ridiculous to hear so much talked of

## A NEW STYLE,

particularly when it was supposed that a clever man could invent it. The real new style was to be attained by the improvements that came about by the altering of proportions through our greater knowledge of statics and the strength of materials, by making our buildings perfectly suitable to the new requirements of our age, by the suiting of our mouldings to the climate, by the greater cultivation of outline, and by a deeper knowledge of our own light and shade. It could not be too often impressed on the young that men could not always judge of what they were capable, so that if a student loved the art sincerely, but appeared to have no capacity for it, he could not be sure of this: his capacity might require much cultivation, and if he wooed the art in season and out of season he might find he had it. Etty, who eventually painted flesh so admirably, was the butt of his fellow-students; but by resolutely pursuing his labours and never losing a moment, he became excellent at his art after some twenty or thirty years of unremitting study. The President added:—"Moderate your wants, and be contented with the poor pecuniary rewards your industry can attain. Your ambition should be to create something that will charm and elevate your fellow-men through centuries. Those who look for money as the main thing should be surveyors or valuers. Nor am I going to treat architecture as a thing to be done in broken time, nor, to look on it as it is mostly looked on now, as a lower branch of the knowledge of the value of land and the price of bricks; nor as an antiquarian revival; but as a creation of the true and the beautiful as understood and felt in our own day. I mainly address myself

## TO THOSE WHO HAVE THE AMBITION

to be poets in marble, stone, brick, iron, and wood, who desire to endow their country with a building that may rival the Parthenon, the Erechtheum, the Propylæum, or the Choragic Monument, the Pantheon of Rome, or with one that may vie with the interior of St. Sophia and St. Mark's, with the Scuola di San Marco, with the Cornaro-Spinelli Palace, or with the Town Hall of Brescia. In some of the fine arts the mere exercise of them is its own reward. In the concord of sweet sounds this is certainly the case, and why should not the creation of the true and beautiful in architecture be its own reward. There have been those great and pure souls that asked for nothing; but were contented to help and raise their fellows without even a thought of fame. Surely such exist among us? Cannot some of us be content to endow our country with a priceless treasure, with a monument that all mankind must admire and be thankful for, without an afterthought of fortune or fame?

## NOTES ON THE COMPETITION DESIGNS AND DRAWINGS.

Mr. ERNEST GEORGE, vice-president, made some brief criticisms on the designs and drawings submitted for the prizes and studentships in the recent competitions. He remarked: With numerous well-executed drawings before us, we are bound to recognise the proficiency that obtains in the matter of draughtsmanship. I suppose when most of the noble monuments of the past were built, there were no such accomplished draughtsmen as many of you. It is a good thing to attain facility with the fingers and a ready method of expressing ideas, and I believe that it helps materially towards design. Yet original ideas are few, while pretty drawings are many, and a taking manner of drawing some-

times conceals the lack of anything to say. The art may become a snare. It is well to keep in mind the fact that architects' drawings are only a means, and not an end. The are not pictures, but they are documents of the architect's scheme. They should convey to his client an idea of the house he is to have; but their first object is to show the craftsman the work that is to be done. The architect who is head and shoulders above the rest of us confesses to the burning of his beautiful drawings after they have served their practical purpose. This is not a custom one would commend. In preparing these drawings some of you will have speculated on what the assessors desired to see. Taste is a varying quantity, and depends with each of us on the condition of the mind with regard to certain forms or colours that appear to us with freshness or with pleasant associations, or that we see after they have been too often played upon or travestied. Perhaps this is especially felt with certain so-called "Queen Anne" features that were pleasing when first introduced by good hands, but which we have seen done to death. In a street we commonly find the most ornate and richly-decorated building is a public-house, and we feel that a gentleman's house must be severely plain. Choice marbles, again, are so freely used in restaurants and in sanitary works that, from association, we become afraid to employ a beautiful material that Nature has placed in our hands. We are familiarised with so much commonplace and meaningless ornament that the eye rests with pleasure on any broad wall-surface, and we are conscious of a reaction in favour of utter simplicity. A cynic has said that life would be endurable but for its pleasures. We feel that the vernacular buildings around us could be tolerated if cleared of all ornaments and futile efforts to please. It requires an artist's hand to dispose and wisely restrain the sculpture or decoration, which becomes a source of delight when it finds its right position. Still, there is a fitness in all things, and if your subject for design be a concert-hall for a wealthy city, or a mansion for a nobleman, you must not apply to it the bare treatment that would be admirable for a barrack.

## THE MEASURED DRAWINGS.

For the measured drawings of "Ancient Buildings in the United Kingdom" six competitors for the medal put in a good appearance. The drawings of Clare College, Cambridge, by Mr. T. Tyrwhitt, have been awarded the prize. This interesting building has been portrayed with thoroughness. We are shown its street front, where stone mullions still obtain, though label mouldings have given place to cornices of Italian origin. The river front, though in harmony with the earlier work, has its fully-developed sash windows, with architraves and keystones. An admirable set of measured drawings of Thaxted Church, Essex, by Mr. Cyril Wontner Smith, receives a Medal of Merit. In "Kot" we have another careful set of drawings, the cloisters at Norwich. The four sides of these cloisters at first suggest repetition, till we note the interesting transition of styles from the Early Decorated to the Late Perpendicular. The mouldings of the various epochs are given with care, though the custom of crowding the paper with mouldings makes them not always legible. Other drawings show care, steady work, and ready draughtsmanship. I do not know whether my colleagues are with me, or whether I am right in making the suggestion that it is not desirable to fill up, with full detail, the whole of each elevation, repeating innumerable mouldings or cusps. I think the balance of the drawing can be kept without all parts being carried to the bitter end, to the weariness of the artist. Personally it distresses me to see mechanical repetition. Prize drawings must not be slovenly or sketchy, and it is, perhaps, difficult to draw the line at anything short of finish.

## THE SOANE MEDALLION.

Of the five designs submitted for the concert-hall, there are points to commend in each, although no one design is considered to reach the required standard for the Soane Medallion. The design "Pan" has style, and there is much that we like in the treatment of the exterior. The arcaded upper story is well conceived, though we think the small niches between the projecting columns are unnecessary, and it would be wasteful to put good sculpture in that shady retirement. Above the bold cornice and balustrade we should

like the building to cease. We think that a building of this type suffers by a show of roofs. These latter are formed to accommodate the secondary hall; but this smaller hall is worth a better position than it gets in this attic story. In the absence of these roofs, the auditorium might have become an imposing feature in the composition. The plan of this building is less satisfactory than the exterior. Probably the difficulty has been to provide the required seating accommodation, and the hall is injured by its three overgrown galleries; the passages would gain by greater width, both for convenience and safety. The design "34" South" has a well-studied plan. The two galleries are in just proportion to the hall, the passages are of fair width, and the smaller hall is treated with consideration. The elevations of the building are not satisfactory, the proportions and composition of the group are not happy, and the design suffers from many stripes, the eye wearying of rustications from the plinth to the cornice. "Quod erat Faciendum" is a design showing thought, and the elevations have a distinct interest. It is not, perhaps, a bad fault that it is very like a church. The square concert-room is not a satisfactory shape, and the aggressive projection in the middle of a side wall for a royal box would not be tolerated by the most loyal of subjects who cared for music. "Cornice" is a bold, rusticated block, after the manner of a Florentine palace. The treatment is daring and original, and is not without dignity. The long line of columns on the flank wall would look well but for the two tiers of openings between the columns, robbing the latter of their effect as a colonnade. An arcaded treatment of these balconies might have worked better. Of "Lyra" one feels that it is rather a theatre than a concert-hall, but the circular form has its advantages. The dome has an awkward shape, which is emphasised by the strongly-marked ribs upon it. There is simplicity in the general treatment, and we do not blame the design for its broad wall-spaces. With the latter, however, we feel the demand for bolder detail where mouldings and projects appear. There is too much equality about the three rows of cornices and the spaces between them, and we should like more interest about the doorways, which have each a glass shelter over them as their prominent feature. It has been decided that no design is sufficiently satisfactory, both inside and out, to merit the distinction of the Soane Medallion; there is, nevertheless, evidence before us of intelligent study and of good work done, and although unsuccessful for the medal, I am sure you will not look upon your work as wasted. Your time has been well spent on a subject of great interest, and the knowledge you have acquired will one day be turned to account. London is not yet provided with its fitting concert-hall.

## THE TITE PRIZE.

"An English Villa and Garden treated in the Italian Style" was, as you know, the subject given last year for the Tite Prize; but the works on that occasion were not considered of sufficient merit to justify the award. The same subject given again has called forth a better response this year from the nine competitors who have entered the lists. Of these schemes, "Andante," by Mr. John Stevens Lee, takes the prize. There is simplicity and propriety about the villa, which, in some designs, has too much the character of a large country house. The plan might in some respects be improved. The central hall with columns would have gained much if it had, in its height, included the first-floor gallery, which would have opened into it. At present this gallery looks out upon the lead flat and skylight—never a comely prospect. The two passages at the ends of the loggia are unnecessary, and might have been included in the loggia. There is art in the scheming of the garden, its features having interest without becoming obstructive. The drawing is incisive and clear, giving good expression to the design. To "Heather," by Mr. Thomas A. Pole, a second prize is awarded. It is a good drawing, showing a house with well-proportioned wings sheltering the upper terrace. The balustrade of this terrace is placed on the edge of a steep bank, where grass would not thrive happily, and I think a wall would have been more suitable in this position. A design distinguished by a device (a circle and triangle) has points of interest and quaint fancy, and there is good character in the house. The manner of the drawing, perhaps, gives it the feeling of being somewhat crowded

and wanting in repose. "Tiber" is one of the less ambitious schemes. It is pleasant and homely, with less effort after features than we find in some of these gardens. The design "White Star" departs from the horizontal and reposeful lines of the Italian treatment. The house is rather suburban in character, and is not quite in sympathy with a formal garden. The rooms are purposely unsymmetrical, the bay windows in each room being brought to a corner, and one end of each bay being cut off by the wall. The villa does not centre with the garden, and we think it desirable that it should do so, when the formal treatment is adopted. I think in devising these gardens a difficulty must have been present to you all; it is that of having no obstacles to surmount in your imaginary garden. In an architectural, or built garden, the incidents that please arise generally from difficulties of level and other problems that have to be fought with; these suggest forms that would hardly occur to one on a clean sheet of paper. There are, nevertheless, many happy devices and suggestions in your several proposals.

#### THE PUGIN STUDENTSHIP.

For this studentship there is a very creditable show, and the subjects are generally well chosen. The prize is awarded to Mr. de Gruchy, whose merit the Institute has had the opportunity of recognising before, and it is a pleasure to see such work as he sends us. A second prize is given to Mr. Bower, and I am glad to find among his studies the grand tower of St. Mary's, Newark. I do not doubt Mr. Bower has studied also the noble interior of this church. Seeing it again the other day, I was impressed by its dignity, unity, and proportion. It possesses those qualities that are attributed rather exclusively to fine Classic buildings. Mr. Fulton gives us good examples of his work. We like the way he has drawn the vigorous detail of the Scotch carver in the screen from Aberdeen. Whilst studying the old examples of carving, he looks also to the original types: his thistles and other foliage are well put in, as are the crucifix and figures. Mr. Fulton is the recipient of the Aldwinckle Prize, and we shall be interested to see the result of his Spanish campaign. Before leaving these various groups of sketches I would remark that they are nearly all honest and direct in their purpose of delineation, the architectural details being the points of interest. There is not the attempt we sometimes see to give a fictitious interest by dwelling on cracks in the masonry, or dots and spots suggesting rotten bricks. We have seen these incidents forced to give a meretricious prettiness to architectural drawings.

#### THE OWEN JONES STUDENTSHIP.

For the Owen Jones Studentship there are but two candidates, and the work does not quite reach the level that has been attained by the late winners of the prize. The studies of ceramic work, including the Arab Hall of the late Lord Leighton, are freely drawn and put in with good colour. There is, however, no range or variety of subject. The other competitor shows greater diversity, but there is a certain hardness and want of freedom about the work, and some lack of harmony and "quality" in the colour, which are drawbacks to the interest of the subjects portrayed.

#### THE GRISSELL GOLD MEDAL.

For the Grissell Gold Medal there are many entries, for the subject of a country church of timber is attractive, and should bring out original suggestions. The design marked "Stavekirke," by Mr. Harbottle Rees, receives this prize. A wall of timber is unsuited to take the thrust of a roof, so the architect helps it with an inner range of posts, forming an outside aisle or passage. There is not, however, much thrust from this roof, as, although the principal has an apparent arch, there is practically a tie-beam from plate to plate. I venture to think the arch is no help to the design. Several of the schemes show a tendency to form arches, sometimes cutting them out of exceptionally large balks of timber, instead of trusting to beams, posts, and struts, which are the natural forms of wood. There are features we like in the good drawing marked "Emce," but we object to the circular-headed windows with vousoirs, a direct following of stone forms. A second prize is awarded to the design "By Lamplight," the work of Mr. W. Stanley Bates. It is a good piece of timber construction, and well-proportioned. The internal design of the roof, with its rather finikin pierced work, is less

commendable. In the view of the exterior one feels that the timber and shingle are overlaid with lines, to the detriment of the drawing.

The President then proceeded to distribute the prizes in accordance with the list published by us last week, p. 85, and a vote of thanks to him having been proposed by Professor T. ROGER SMITH, he briefly replied thereto.

#### REFERENCE BOOKS ON ORNAMENT AND THE DECORATIVE ARTS.\*

(Concluded from page 90.)

**T**AKING, now, the special branches of decorative art in alphabetical order, to avoid invidious distinction, the first with which I have to deal is

##### ARCHITECTURAL ORNAMENT.

Under this head I intend mentioning a few works which it would be difficult to include elsewhere, and first I would call attention to Mr. J. K. Colling's "English Gothic Ornaments," 2 vols., 4to, issued in the fifties, containing over 200 lithographic plates drawn by the author, some being in colours. Some years later he issued a 4to volume under the title of "Art Foliage for Sculpture and Decoration," consisting entirely of his own designs, and after that, "Examples of English Mediæval Foliage and Colour Decoration," many of the plates in which had appeared in "English Gothic Ornaments." Augustus Pugin in 1821 had published a volume of illustrations of "Gothic Stone Ornaments," a work of great value, and the examples differ from those drawn by Mr. Colling. An exceedingly beautiful volume of "Architectural Ornament in Italy" was published a few years since. It consists of 100 permanent photographic plates selected by Prof. Nicolai, of Dresden, and, on account of the large scale of the details and the delicacy of the printing, it is of the greatest value for study, and is far preferable to the works which illustrate modern German examples, not unfrequently asked for. In the Trocadero Museum, Paris, is an unrivalled collection of casts of architectural sculpture of all countries and times, and of this a very comprehensive series of reproductions has recently been published in three small folio volumes, at moderate prices. The photographic reproductions now issued so reasonably, giving perfectly faithful representations of the minutest detail, are indispensable in the section of which I am treating, and a collection of such is far more valuable than a series of casts costing many pounds. Next we come to the books dealing with Arms and Armour. Here the authorities are Meyrick's "Illustrations Ancient Armour," 3 vols., small folio, issued in 1824, and two others, published in 1833, illustrating the celebrated collection at Goodrich Court in Herefordshire. The best smaller work is Hewett's "Ancient Arms and Weapons in Europe," 3 vols., 8vo, issued in 1860, while Mr. Starkie Gardner has just published a little volume, forming one of the "Portfolio" monographs, on "Armour in England." The Art of Bookbinding is now practised by so many students at art schools that the library should contain some standard textbook, and for this I recommend Mr. Zaehnsdorf's practical little work. The books with examples of old bindings are numerous; but I think the best are the two folio volumes recently issued by Mr. W. Y. Fletcher on "English and Foreign Bookbindings" respectively. There is also a small book on "English and French Bookbindings" by this gentleman, composed of two of the excellent monographs of the "Portfolio" series, which forms a good substitute for the larger works.

##### BOOK ILLUSTRATION.

The volumes which are best worthy of a place in our library for reference on this subject are Mr. Walter Crane's "Decorative Illustration of Books," Pennell's "Pen Drawing and Pen Draughtsmen," and Mr. C. G. Harper's "English Pen Artists." The first gives examples by old masters, and the two latter copious illustrations showing the styles of leading draughtsmen of to-day in all countries.

##### COLOUR DECORATION.

I have already mentioned the works of Owen Jones and Racinet under "General Reference Books," and these amply fill the need for ornamental detail in colour; but the special applica-

tion of ornament to the decoration of modern buildings requires separate elucidation, and for this purpose I would add Daly's "Décorations Intérieures Peintes," 2 vols., folio, the examples in which are beautifully printed in colours, and represent decorations carried out in Paris. This is a work of exceptional value to decorators, as it sets before them complete schemes of polychromatic decoration. A very fine work was issued some three years ago under the title of "La Peinture Décorative en France," by Gélis-Didot and Lafille, giving a fine series of reproductions of water-colour drawings made by the artists from the churches and cathedrals of France, and I know of nothing else so useful for church decoration. The only work of the kind illustrating English church decoration in colour is "Decorative Painting Applied to English Architecture," by E. L. Blackburne, which appeared so far back as 1847, and, though valuable, is fragmentary. One would like to see it replaced by a more important volume on the subject. Here I would add Louis Gruner's "Fresco Decorations and Stuccos of Palaces and Churches in Italy during the XVth and XVIIth Centuries." The plates in this folio are most minutely engraved, and some are fully coloured, while two coloured plates present a key to the colouring of the remainder. I should have mentioned that on the theory of colour the best little books to consult are Professor Church's "Colour," Field's "Chromotography," and that by the celebrated French chemist, Dr. Chevreul, who died some two years since, aged over 100. For Costume I have already referred to the works of Pugin and Racinet; but in addition to these I think the library should acquire Planche's "Encyclopædia of English Costume," two vols., 4to, published in 1876, Fairholt's "History of Costume in England," now reprinted, and forming two small volumes in Bohn's Library, and Henry Shaw's "Dresses and Decorations of the Middle Ages," collected from various authentic sources, two vols., issued in 1858, containing interesting plates, beautifully drawn and coloured.

##### FIGURE DRAWING AND SCULPTURE.

It goes without saying that before the artist can draw the figure he must have studied artistic anatomy, and the best textbooks on this subject are Duval's "Artistic Anatomy," a little book of principles, translated from the French, Marshall's "Anatomy for Artists," Sparkes' "Artistic Anatomy," and a work recently published by Professor Thompson on "Art Anatomy for Students," which is of great value, as it gives a number of photographs from nature as well as diagrams. The textbook on figure-drawing is by Mr. Hatton, of the Durham College of Science, entitled "Figure-Drawing and Composition." One must not overlook Walker's "Analysis and Classification of Beauty in Woman," with its fine plates from life by Howard, in 8vo, the first edition of which was issued in 1836. The most complete series of decorative figure studies ever published is in a fine book, known to some of you, by a celebrated French sculptor, M. A. Carrier-Belleuse, entitled "L'Application de la Figure Humaine à la Décoration," which in its 200 plates presents a wonderfully facile series of figure compositions. The fountain source for drawings of cupids, armours, &c., is the work of the celebrated French artist François Boucher, of the 18th century, and a book of a hundred plates of reproductions of his best designs, published in Paris some years since, is still obtainable. Some of the works referred to under "Architectural Ornament" contain examples of figure decoration. For ancient sculpture, I should refer to Miss Mitchell's large octavo "History of Ancient Sculpture," issued in 1883, and for larger illustrations to the two folio volumes issued by the Dilettanti Society in 1809 and 1835. The engravings in these volumes are choicely executed, and the subjects illustrated include examples from Egypt, Greece, and Rome, in marble, bronze, &c. Examples of Greek sculpture will also be found in Stuart and Revett's "Antiquities of Athens," which would be in the architectural section of the library. Flaxman's "Lectures on the Art of Sculpture," delivered at the Royal Academy between 1813 and 1826, were issued in an 8vo volume in 1829, and the illustrations and lectures on such subjects as composition, style, and drapery render it of special value. For a history of "Renaissance Sculpture" we must read Perkin's scarce and well-illustrated volumes on the Italian and Tuscan sculptors.

\* Read before the Twentieth Annual Meeting of the Library Association, by Mr. HERBERT BATSFORD.

## FLORAL DECORATION AND DESIGN.

This is, as you are aware, a very important division of decorative art. The textbooks may be set down as Lewis F. Day's "Nature in Ornament," Hugh Stannus's "Natural and Artificial Foliage," and Lilley and Midgley's "Book of Studies in Plant-Form." Professor Hulme in 1868 published his useful volume of "Sketches from Nature of Plant-Form," giving details of plants and their adaptability to decoration, and followed this in 1874 by a volume entitled "Plants, their Natural Growth and Ornamental Treatment." These are useful to the artist, but doubtless Professor Hulme would admit that they could be improved upon, could they be issued anew. Then there is the folio volume published by Mr. G. C. Haité, in 1886, dealing with "Plant-Studies," which gives to a good scale drawings of plants made for the decorative artist, with various structural and ornamental details. A very fine series of drawings has been published by a French artist, M. Lambert, consisting of 80 folio plates, printed in colour in imitation of water-colour drawings. A collection of 120 colotype illustrations has also been lately issued under the title of "L'Encyclopédie de la Fleur," giving nearly 300 groupings and artistic arrangements of flowers and fruit, photographed from nature, and I cannot but mention the grand volumes of Herr Gerlach, on "The Plant in Ornament." These are very costly, and many of the illustrations have, in my opinion, no permanent value. This brings us to the important section devoted to Furniture and Woodwork. The only histories are, first, the translation of M. Jaquemart's "Histoire du Mobilier," published in 1873, which deals mainly with French work, and Mr. Lichfield's "Illustrated History of Furniture," first published some five years since, and no doubt familiar to most of you. This is more general, but largely devoted to English work. Two excellent little volumes by M. de Champeaux in the "Bibliothèque de l'Enseignement des Beaux-Arts" deal with French furniture only. For good examples of Early English furniture we must turn to Shaw's "Specimens of Ancient Furniture," 4to, published in 1836; Marshall's "Antique Carved Furniture and Woodwork," issued in 1888; and the two volumes compiled by the late Mr. W. Bliss Sanders. For the later styles we must refer to the works of the celebrated furniture designers of the last century—Chippendale's "The Gentleman and Cabinet-Makers' Director," first published in 1754; Hepplewhite's "Cabinet-Makers' and Upholsterers' Guide," first edition 1791; and Sheraton's "Cabinet-Makers' and Upholsterers' Guide," 1793. Copies of the original editions are rare and costly; but reproductions of all have appeared, and are to be obtained at moderate prices. An interesting volume has just been written by a lady—Mrs. Warren Clouston—on the Chippendale period of furniture in England, telling us all that can be found by research and experience about these great designers. The volume has numerous interesting illustrations. There is a series of portfolios illustrating "Carvings in the South Kensington Museum," and more recently one devoted to "French Carvings in the National Museum" has been issued. The illustrations in these last three portfolios are collotypes from special photographs. For French furniture the designer will find much that is required in the works of Viollet-le-Duc and Havard already referred to; but some other works may be mentioned. Scottish woodwork has been very completely illustrated in a book entitled "Scottish Woodwork of the Sixteenth and Seventeenth Centuries," the examples being drawn by an architect, Mr. J. W. Small. A beautiful series of 60 photographic plates of Renaissance "Italian Woodwork" has been published by Herr Schütz. Perhaps in this section I had better include a few works on Interior Decoration, although the majority of these were touched upon in my former paper on architectural books. For old English work we cannot do better than consult Nash's "Mansions of England in the Olden Time," too well known to need description, and Richardson's "Studies of Old English Mansions," also in four vols., folio, issued between 1841-3, a work of great value, as its illustrations include not only views, but also details of furniture, woodwork, ceilings, plate, &c. There are some fine interiors in Mr. Gotch's more recent work on "The Architecture of the Renaissance in England," and a companion work on the later English styles is appearing under the editorship of two architects, Mr. J. Belcher and Mr. E. E.

Macartney. I have spoken of the multiplicity of works on French furniture and woodwork, and in addition to the standard volumes mentioned I should recommend the acquisition of Rouyer's "La Renaissance de François Ier à Louis XIII.—Décorations Intérieures," with engraved plates. There is no other work worthily illustrating the woodwork of the Early French Renaissance. The later periods are most adequately represented in M. César Daly's "Motifs Historiques d'Architecture et de Sculpture," which has 250 steel engravings executed with that extravagant care characteristic of so many French publications. For old German woodwork, the most complete book is Paukert's "Die Zimmergotik," a folio containing nearly 200 photo-lithographic plates, full of useful details. The library must of necessity have some authority on heraldry, and the most comprehensive work is the library edition of the Rev. C. Boutell's "Heraldry, Historical and Popular," the last edition of which was published in 1864. This can be supplemented by such works as Berry's "Encyclopædia of Heraldry," which, although it appeared as long since as 1828, is still a standard work. There should also be added Fox Davis's "Public Arms," 4to, first issued in 1891, and now obtainable at a reduced rate; Fairbairn's "Book of Family Crests," 2 vols., and Burke's "Heraldic Illustrations," 3 vols., 8vo. Burke's "General Armoury" is also a very useful book of reference. Alphabets and Illumination I propose to include under one head. Amongst books of alphabets is "A Handbook of Mediæval Alphabets," by Henry Shaw, whom I have before named. He was also the author of an excellent quarto volume on "Illuminated Ornaments from Manuscripts," with beautiful coloured plates, published by Pickering, and of "Alphabets, Numerals, and Devices of the Middle Ages." The "Art of Illumination as Practised in Europe from the Earliest Ages," by Tymms and Sir M. Digby Wyatt, published in 1860, contains 100 plates of alphabets and initial letters, and is a work of considerable scope and interest, quite encyclopædic in character. M. Sylvestre, author of the celebrated work on Palæography, published an "Alphabet Album" in 1843, which contains a number of examples copied from various sources. A little book by Mr. E. F. Strange (of the South Kensington Museum) is a valuable contribution to the subject; while for Renaissance alphabets one cannot do better than refer to M. Sylvestre's book, and to two octavo volumes recently issued by Signor Ongania, the great Italian publisher, entitled "L'Arte della Stampe del Rinascimento Italiano-Venezia." You will be glad to know that Mr. Lewis F. Day will shortly publish a collection of "Old and New Alphabets," specially selected by him. It should not be overlooked that Owen Jones published a folio entitled "1,001 Initial Letters," designed and illuminated by himself, most of which were incorporated in his "Victoria Psalter." On illumination, the books illustrating old examples, in addition to those I have mentioned, are Noel Humphrey's folio "The Illuminated Books of the Middle Ages," issued in 1849, and Westwood's "Facsimiles of Irish Manuscripts," also Westwood's "Paleographia Sacra Pictoria," or facsimiles of illuminated versions of the Bible, 4to, published in 1843-5; the two former are, however, somewhat expensive. For works giving examples of illumination executed in recent times I think the finest are Owen Jones's volume of designs illustrating the Psalms, and Audsley's "Sermon on the Mount," folios published some years ago at high price, but now to be met with at very low ones.

## JAPANESE ART.

Considering the important influence that Japanese art has exercised upon modern design, I think a separate place may well be given to it here. The most important English books on the subject are Audsley's and Bowes's "Ceramic Art of Japan," two vols., folio, issued in 1875, with very fine plates, and the same author's "Ornamental Arts of Japan," issued in four folio portfolios, containing 100 plates, most of which are beautifully printed in chromolithography. I should also mention Cutler's "Grammar of Japanese Ornament and Design," one of the first books to analyse Japanese Decorative work, while Dr. Anderson's "Pictorial Arts of Japan," 4 vols., folio, is an important and authoritative work, but, as its title proclaims, is chiefly devoted to the works of painters, not decorative artists. It must be borne in mind that the most

direct, and probably the best method of studying the Japanese design is from the native sketch and design-books, which are very numerous and mostly readily obtainable. I will content myself with enumerating the three or four small oblong geometric design-books, and the very clever studies of birds and flowers, each forming three volumes, by Bairei Kono and Watanehei Seitei, the two best-known living artists in Japan. A few specimens of the famous coloured prints, such as can be met with in albums, or in separate sheets, would make a very interesting addition to this part of the library; but they require some little care in selection in order to secure good colouring. Under the head of

## METAL WORK.

I will include works on iron and the precious metals; but on the latter I am only able to suggest to you the two octavos on "Old English and French Plate," by Mr. Cripps, and a large octavo, richly illustrated, by Mr. Havard, to whose "Dictionnaire de l'Ameublement" I have already referred. His new work is entitled "L'Histoire de l'Orfèvrerie," and it contains a splendid series of illustrations. A volume has also been published partly illustrating, by photo-gravure plates, a special exhibit of Old English Plate at Cambridge in 1895, and it is only to be regretted that more of the collection was not represented. No better history of metal-work as a whole has been published than Sir M. Digby Wyatt's folio, issued in 1852, which has a series of 50 good plates of choice examples from different countries. But for a sketch of the history of Artistic Ironwork we must refer to Mr. Starkie Gardner's two little volumes recently issued in the South Kensington Handbook series. I have not previously made individual reference to the volumes in this series, but I make an exception in this case, for they are of special value, and have only recently appeared. Professor Meyer, author of the "Handbook of Ornament," has also written a work on "Smiths'-work," translation of which has been brought out under the title of "Art Smithing." Some practical details of the craft are here dealt with, and many illustrations are included. English ironwork has hitherto been but sparsely illustrated, but an interesting series of examples of late work is shown in Ebbett's "Decorative Wrought Ironwork of the 17th and 18th Centuries," a small folio published some years since. Recently a reproduction of a scarce book of "Designs for Ironwork," by John Tijou, has been brought out. Mr. Starkie Gardner tells us that Tijou undoubtedly designed the iron gates of Hampton Court Palace and those of St. Paul's Cathedral, although some of the designs in the book are not exactly as executed. It is to be hoped that we may get a comprehensive work on English ironwork from Mr. Starkie Gardner before long, as such a work is much needed. A rare volume of Designs, by Fordrin, a French smith, contemporary with Tijou, has been reproduced; the designs are very graceful. The best works illustrating foreign ironwork are Heftner-Alteneck's two small folios, "Eisenwerke des Mittelalters." The first series was also issued under the title "Serrurerie du Moyen Age." The second series may not be known to you, as it was published many years after the first, and only under the German title. Herr F. Halselmann, an architect of Munich, formed a very remarkable collection of knockers, keys, finger-plates, &c., and this has been illustrated in a moderately-priced folio, the plates being reproduced from photographs taken from the objects as they hung upon the walls. I think I may say that this collection has a unique value. Another work of the greatest possible use, and of which I ought to have made earlier mention, is T. H. King's "L'Orfèvrerie et les Ouvrages en Metal du Moyen Age." Probably many of you know this author's remarkable "Study Book of the Architecture of the Middle Ages." In his book on metal-work he gives 200 folio plates of measured—one might almost say working—drawings of ecclesiastical metal-work, entirely Continental, and the whole of the measurements and drawings were made by Mr. King himself, occupying some twenty years of his life. A German folio, entitled "Schmiedekunst," has 100 plates illustrating old German ironwork, and is issued at a moderate price. Numerous examples of domestic ironwork are illustrated in this work. The fine specimens of Spanish ironwork are to be found the rich "Rejas" or screens in the churches and cathedrals. Many of these are illustrated in a recent folio volume of drawings of "Renaissance

Architecture and Ornament in Spain," by Mr. A. N. Prentice, a young architect who has twice visited Spain. The subject of

#### MOSAIC WORK

claims our attention, and here the authorities are not numerous. The best known is Sir M. Digby Wyatt's folio, entitled "Specimens of the Geometric Mosaics of the Middle Ages," with a brief historical account of the art. This has some plates printed in gold and colour, but it has been pointed out that the specimens do not show the tesserae of the mosaics. A young architect, Mr. A. T. Bolton, recently published a folio of rubbings of "Some Roman and Pompeian Mosaics," in the hope that they would be of special value to artists. In addition to this, we have Henry Shaw's "Specimens of Tile Pavements," another quarto by this versatile archaeologist, issued in 1858, with numerous coloured examples, and a French work, Amé's "Carrelages Emailés du Moyen-Age et de la Renaissance," a 4to published in 1859, but not often to be met with now. Another volume, the great value of which is not to be judged from its title, is "Nouveaux Mélanges d'Archéologie," by two celebrated French archaeologists, MM. Cahier and Martin. It contains 250 plates, printed in tints, of innumerable geometric tiles and pavings selected from foreign cathedrals and churches. Opportunity should be sought of obtaining some plates of William Fowler's fine folio coloured engravings of "Mosaic Pavements and Stained Glass in England," issued between the years 1796-1820. A complete set is scarce and costly. Turning our attention now to pottery and porcelain, and taking English pottery first, the best-known book is Jewitt's "Ceramic Art of Great Britain," 2 vols., 8vo. Further works on English pottery are Binn's "Two Centuries of Ceramic Art in Worcester" (be careful to have the second edition), Solon's "Art of the Old English Potter," Owen's "A Century of Potting at Bristol," Haslem's "Old Derby Pottery," and Miss Meteyard's "Life of Josiah Wedgwood." All these are octavos. Wedgwood's work has been more fully illustrated in three small folio volumes, containing autotyped reproductions from photographs, entitled "Choice Examples of Wedgwood Art," "Memorials of Wedgwood," and "Wedgwood and His Work." Mr. Birch's "History of Ancient Pottery" is the best authority on this period, and for a general survey of the subject we cannot do better than refer to Marryatt's "History," and Mrs. Palliser's translation of M. Jacquemart's "History of the Ceramic Art," issued in 1877, also to Chaffers' "Ceramic Gallery," 2 vols., large 8vo, containing 600 photographic plates of choice examples of the different wares. Of course, Chaffers' "Marks and Monograms on Pottery and Porcelain" should be in every library. To Japanese art I have previously referred, and have there mentioned the works on the pottery of that country. The library should try to secure the grand works of Delange, entitled "Euvres de Bernard Pallisy," "Faïence Italienne," and "Faïence de Henry II.," for quite irrespective of the worth of these books in the illustration of their subjects, the beautiful execution of their plates and the diversity of ornament shown in the examples render them invaluable as aids in design. There are numerous works on

#### STAINED GLASS,

and some fine folios illustrating the glass in certain Continental cathedrals; but we must content ourselves with works treating the subject more generally. I may remark that it is almost an impossibility to adequately represent a coloured window by means of chromo-lithography; but Lévy and Capronnier's "Histoire de la Peinture sur Verre," a 4to issued in Brussels in 1860, contains some of the best reproductions which have appeared. It has 37 plates, most of which are richly coloured. Then comes Winston's "Inquiry into the Different Styles Observable in Ancient Glass-Painting in England," 2 vols., 8vo, first issued in 1847, and one must not forget another book issued by him, not so well known, but of great value, entitled "Memoirs Illustrative of the Art of Glass-Painting," which is fully illustrated. The most exhaustive and valuable history is Mr. N. H. J. Westlake's "History of Design in Painted Glass," in all periods and countries, now completed in four volumes, small folio, profusely illustrated in black and white. I daresay many of you have already noticed that Mr. Lewis F. Day, who passed some of the early years of his art life with artists in

stained-glass, has just published a book, the result of 25 years' study of his subject, which he calls "Windows: a Book about Stained and Painted Glass," which I have reason to believe will prove as useful and instructive as his other works. Some good examples, particularly of Belgian work, are to be found in two folios, known as "Divers Works of Early Masters in Ecclesiastical Decoration," published in 1846, some plates of which were drawn by Owen Jones, and there are reliable historical accounts of the glass illustrated. For special details, such as lead-glazing, we must refer to an octavo issued in 1849 by the late Sir A. W. Franks, called "A Book of Ornamental Glazing Quarries," and to the reproduction of "A Book of Sundry Draughts, Principally Serving for Glaziers," a rare 8vo, first issued in 1615 by W. Geddes, and reproduced in 1848 by our oft-mentioned authority, Henry Shaw. On Domestic Glass I am sorry to say we have only an expensive book to refer to—namely, an illustrated catalogue of the collection formed by the late Mr. Felix Slade, and now in the British Museum. This catalogue is beautifully produced, and was published for private circulation only in 1871. The collection itself was valued at £20,000, so we may gather that the catalogue illustrates some beautiful work. There is an interesting little book by Pellatt, entitled "Curiosities of Glass-making," with coloured plates, published in 1949. For an exhaustive illustrative account of ancient glass, our guide must be Deville's "L'Art de la Verrerie dans l'Antiquité," a large 4to issued in 1873, which has 112 tinted and coloured plates of examples of historic glass. On Symbolism the library should have one or two authorities, and these should be Mrs. Jameson's beautiful volumes, "Sacred and Legendary Art," now issued at a reduced price, and Miss Louisa Twining's "Symbols and Emblems of Art," a 4to published in 1852, and on this subject, again, you will find Pugin's "Glossary" of great value for reference. Audsley's "Handbook of Christian Symbolism" is a concise little book on the subject, and is the only small one having coloured plates. With the books on Textile Design I will include those on Lace and Embroidery. The two most important works that have been published illustrating textile fabrics are Dupont-Auberville's "L'Ornement des Tissus," which is an encyclopaedia of textile design, showing about 2,000 examples chronologically arranged, and printed in colours, with historical notes, and Dr. Fischbach's "Ornamente der Gewebe," which illustrates on 160 plates about 1,000 designs compiled from important collections. Mention should particularly be made of the important series of permanent photographic reproductions, made by Professor Kumsch, of the remarkable collection of textile patterns in the Royal Museum at Dresden, issued in several portfolios. On lace-work, the best known authority is Mrs. Palliser's "History of Lace," an 8vo first issued in 1865, but this is not to be compared with the scarce folio by M. Sequin, entitled "Histoire de la Dentelle." One of Herr Kumsch's portfolios illustrates the lace and embroidery in the Dresden Museum, and other folios have been published illustrating special collections. For embroidery there are two scarce octavos issued by Mrs. Dolby on "Ecclesiastical Embroidery and Church Vestments"; this is also treated in Pugin's "Glossary of Ecclesiastical Costume," previously referred to. Lady Marion Alford's "Needlework as an Art," and Mrs. Barber's "Specimens of Old Embroidery," a small folio giving coloured illustrations of some 30 early examples, are important; but above all we must place a large folio, published some four years since at Angers, entitled "La Broderie," by M. D. Farcy. This has 160 plates, and forms the most valuable contribution to the illustration of the subject which has yet appeared.

#### WOOD-CARVING.

Many of the works I should have recommended as dealing with this subject have been mentioned under the heading of woodwork; but for good studies, in addition to those there referred to, I suggest Lessing's "Holschnitzereien," which contains over 50 colotype plates of the woodwork of the 15th and 16th centuries in the Berlin Museum, while for Gothic work a volume issued recently by Mr. Franklyn A. Crallan, entitled "Details of Gothic Wood-Carving from the 14th and 15th Centuries," may be commended. There are several small books of instruction by Bemrose, Leland, Phillips, and Miss Rowe, of the School of Art Wood-Carving, amongst others. It is important to refer to my list of books on Furni-

ture, Woodwork, and Architectural Ornament, as so many of the designs contained in the books referred to there are peculiarly adaptable to wood-carving of the more elaborate description. Very few works have been published which one can safely recommend as illustrating Modern Art. It is surmised that the library will contain some of the leading art magazines, and one must not forget the grand folio, illustrating the work of Alfred Stevens, the English Michael Angelo, prepared as a labour of love by Mr. Hugh Stannus, or Mr. Aymer Vallance's recent "Life of William Morris"; but both of these are costly. Some of Mr. Walter Crane's best designs have been published in book form, notably in such works as the "The First of May" and "The Echoes of Hellas." The lives of artists, such as Sir Edward Burne-Jones, Albert Moore, Sir Frederic Leighton, and many others, hardly come within the scope of my list, as although most of them applied some of their powers to decorative art, it is by their works as artists that they are chiefly remembered. Early in the preparation of my paper I found a difficulty in limiting the number of works on the various subjects, and I feel that I am speaking to many, who, in their professional capacity, are acquainted not only with a number of works to which I have directed attention, but also with many which I have not mentioned. Had time allowed, I should have felt tempted to speak of more volumes, but this might have led to a departure from the limits of my title.

#### FIREPROOF CONSTRUCTION OF DOMESTIC BUILDINGS.\*

IF a certain amount of timber were allotted to be used in the construction of a dwelling-house, and the instructions were that it was to be distributed in a way that, should the window curtains or carpets take fire from a spark, a lighted match, or the upsetting of a paraffin lamp, some portion of the timber would be fairly certain to catch alight and the fire to spread with the greatest rapidity, no better arrangement could be devised than the one usually adopted in house building. Wood joists, about 12in. apart, reaching from wall to wall, over the entire area of the buildings, and resting on wood wall plates, is the first step in this direction; wood floor-boards to form a walking surface cross these at right angles on top, and wood plastering laths pass at right angles beneath to form the ceilings of rooms below; a similar arrangement is adopted for lighting coal fires in ordinary grates, the crossing and recrossing and the space between affording excellent facilities for the fire to play round the wood, and air to circulate and to assist combustion. This arrangement, which begins with the ground floor, is repeated every three or four yards in height to the top of the building, where the roof, constructed with wood ceiling joists, wood rafters, and wood ceiling and slate laths is ready to supply its quota of combustible materials on the slightest provocation. Wood partitions for dividing the floor area into rooms are often formed of timber quarterings placed 12in. apart, cross-lathed on both sides, and affording unusual facilities for carrying the flames upwards from floor to floor. Bricks are sometimes built in between the wood uprights, and these to a great extent lessen the danger. Wood skirtings, dadoes, match-boarding, or wainscoting are fixed round rooms to wood battens nailed to wood plugs, driven into the mortar joints, and sometimes into the chimney-flues. A space is usually left between the back of this woodwork and the wall to prevent decay; the air having unchecked circulation through this space, a fire is rapidly communicated from room to room. Wood stairs commence at the lowest floor and finish at the highest, and, as a rule, there is practically no disconnection of wood between the bottom floor of a house and the top floor, and no severance or barrier to check ascending flames; a strong upward current of heated air is provided at the bottom by the well-hole of the stairs, and when once the latter are well alight all escape from the upper rooms is cut off. A startling statement is to be found in the London Fire Brigade's annual report—viz., that for the last thirty years the number of fires and the loss of life therefrom have gradually increased; the total number of fires in 1866 was 1,338, 44 lives being lost, as against 3,494 fires in

\* By THOMAS POTTER, of Alresford, Hants. A paper read at the Society of Arts on Wednesday evening, Jan. 26, 1898.



1896 and 106 lives lost. The expression "fireproof" has a conditional meaning; no building can be said to be absolutely fireproof; sufficient time and material for prolonged combustion are all that is necessary to reduce the most fire-resisting building to ruins. It has, however, become usual to designate those buildings fireproof where the materials used in construction are incombustible. Fire-resisting would be more appropriate, but, except in the Building Act, it is seldom used. The only explanation that can be given why fireproofing is comparatively so little adopted at the present time is that the great majority of houses are erected to sell, or to let at an annual rental; and, as buildings can be insured for their full value, the owner is secured from a monetary loss. A good deal of misconception exists as to which portions of a house should be rendered fire-resisting, and also an exaggerated notion as to the extra cost. The external walls of houses are almost without exception compelled to be built of incombustible materials; but the two factors in construction which are the main cause of loss of life by fire in domestic buildings are the wood stairs and the wood floors, and assuming these to be formed of materials that will resist a moderate fire for a couple of hours at most, the skirtings, doors, door surroundings, windows, fittings, carpets, curtains, and furniture combined would not in themselves be a source of much danger beyond the apartment containing them, and may, therefore, be considered as factors of secondary importance in connection with fire resistance. But so far as regards skirtings they would always be better if constructed with Portland, Keene's, or Parian cement. There is no objection to cement skirtings, except that they cost somewhat more than wood; they are far more durable, solid, not readily damaged, and non-absorbent, and even on sanitary grounds alone should become more general than is the case. Stairs should be of concrete—stone is unreliable. The cost of concrete stairs is more than wood stairs, but unless of intricate design by no means a serious item. Concrete stairs are constructed by casting each step in a mould, or casting the whole flight *in situ*, and the principle of construction is now well understood. The best materials for concrete stairs, both for strength and fire resistance, are Portland cement and crushed bricks—firebrick by preference—clinker from furnaces or slag from iron ore. Oak and other hardwood stairs of a defined thickness are classed as fire-resisting under the London Building Act, but given sufficient fire they add fuel to the flames. Wainscoting, dadoes, and wood cornices can be entirely dispensed with where protection from fire is of paramount importance, or if necessary formed with cement. Wood liftings and boxing shutters can well give way to revolving shutters of steel or hard wood. There is but trifling danger in the latter because the amount of wood required is so small that it need scarcely be taken into account. Considering the neatness and efficacy of revolving shutters, it is strange they should not be more generally adopted for houses where shutters are considered necessary, especially as the cost is less than the ponderous boxing shutters. The portions of sash-frames more exposed than others are the inside lining, pulley stiles, heads and sills, and if these were made of teak, which would resist any moderate fire after the paint on the surface had burned away, another element of danger would be avoided. The extra cost would be, possibly, from 8s. to 15s. per window, according to size. Architraves to doors and windows, and window-jambes or linings, can be formed of cement at a somewhat increased cost, where the use of wood is not desirable; but door-jambes, doors, windows, and fittings, such as cupboards, dressers, linen-presses, shelving, and the like, must apparently still be of wood, for there is no other material which serves the purposes equally as well for habitable buildings. The wood just named in an ordinary building is classed under the general term of joinery, and is mainly exposed to view. But the dangerous factor in a building is the hidden timber, which is of much greater proportion, and being practically out of sight, may smoulder and burst into flames without any previous warning whatever. Under this head we get floor-joists, partitions, wall-plates, templates, lintels, roof-timbers, occasionally wood battening fixed against brick walls for lathing thereto, or for matchboarding. It is common knowledge to everyone engaged in building operations that all

these can be dispensed with, and incombustible materials substituted with no more trouble, but at some increase of cost, and the latter is the crux of the whole matter. In place of partitions formed of wood and lath-and-plaster, they can now be constructed in various ways of materials that will not burn, such as iron uprights, metallic lathing and ordinary plaster, solid plaster with iron rods imbedded therein, fireproof blocks, breeze, concrete, and other materials, all of which are light and fire-resisting. Fireproof cokebreeze lintels, in which small metal tension-rods are imbedded, for use internally over doors and windows, are readily obtainable. Cokebreeze blocks or bricks to insert in walls for fixing joinery thereto are in every way preferable to, and better than, wood; and if new or old walls require to be battened for plastering, as is practised in external walls of some seaside houses to prevent rain from penetrating, metallic lathing can be fixed to metal lathing bars secured by galvanised wall-hooks. Externally, the roof is the dangerous factor in construction; where bargeboards, dormer windows, and skylight frames are in evidence, danger exists if a fire is in progress in the neighbourhood through sparks being carried by the wind. Under the old Building Act, windows had to be set back at least  $4\frac{1}{2}$  in. from the face of any wall, but now they may be flush therewith. All the outside wood window linings in this arrangement can now be exposed; under the old Act they were almost entirely out of harm's way in the brickwork reveal. Fireproof roofs are obviously more difficult to construct than the usual wood type, except a flat form is substituted, and although objections may be made to flat roofs for country houses and suburban villas on the ground of appearance, there can be but few reasons why they should not be adopted in streets in towns. In addition to safety from fire, flat roofs do away with the great danger in towns arising from tiles and slates being deposited on the heads of foot passengers during high winds; they also save the annual recurring cost of tile and slate repairs, and the danger of flooding from choked lead gutters and down pipes. They have other advantages in connection with workmen's flats and similar buildings where the laundry is on the top floor, in being available for drying-places, and there is no reason why flower-beds and gardens should not be established thereon. Flat roofs are usually constructed in much the same way as fireproof floors, but laid to a slight inclination to carry rain-water away into the stack-pipes, and covered with the best mineral asphalt; but concrete and cement alone, with the greatest care, will not form a watertight roof. A roof of this description should be more durable than others, and entirely avoid the necessity of repairs for almost an indefinite period. The cost, too, would in many positions not exceed that of the ordinary slate or tile roof, lead gutters and other accessories taken into account; while as regards security from fire, not a particle of wood need enter into their construction. Fireproof roofs are being adopted for some buildings, but by far the great minority; and but little difference of opinion exists as to what materials should be used, and how they should be applied. But a fireproof roof is of no avail if the floors are constructed of wood, and when we come to fireproof floors we have to deal with a factor in construction upon which opinion differs to a very great extent. As a result, except where Building Acts and by-laws compel their adoption, they are, comparatively speaking, but little used. The reasons for this are many. By some persons they are supposed to take up much more space than wood; that even if covered with wood flooring they are still cold to walk upon; that the weight is excessive; that they conduct sound more readily than wood; and other objections which do not, or need not, exist; but the principal one is, as in many other matters connected with the erection of new buildings—cost. They are regarded as a "luxury" in construction, and when estimates have to be reduced it is often the case that the first thing to go (if the Building Act permits) is the fireproof floors. We have heard of many wide estimates as to the cost of fireproof construction above that of ordinary construction, ranging from 10 to 50 per cent. There will always be a considerable difference in the ratio of cost, for a building with no pretensions to internal decoration or external architecture, such as workmen's flats, requires equally as much flooring as a mansion costing twice as much but of the same size. Taking

average buildings of moderate pretensions, it will be found that wood floors complete, including the wood lathing for ceilings, cost, on an average about 5 to  $7\frac{1}{2}$  per cent. of the total outlay, and that fireproof floors average about double that of wood floors. Assuming, therefore, that a house costs £2,000 to build, and is of the annual value of £150, the fireproof floors at the very utmost should work out at a cost not exceeding £150 in excess of wood floors, and this at 5 per cent. would increase the rent by £7 10s. a year. Fireproof roofs cost but little more than the usual kind, and the extra expenditure on stairs and all the other details of construction enumerated, except architraves to doors, which are not strictly necessary to be of cement, would be well covered by another £150; so that for £15 a year, at most, increase of rental on a house of the estimated annual value of £150, the owner would gain by having fewer repairs to pay for, and the tenant would gain by reason of its healthfulness, freedom from vermin, and security against fire. If a large reduction of fire insurance premium on both house and its contents was obtainable—and it ought to be through danger from fire being almost *nil*—there should be practically very little increased rental necessary. On hygienic grounds, fireproof floors have not received the consideration they should do. In external walls of buildings it is sometimes the practice to insert ventilating bricks to admit air to the floor timbers, with a view to prevent their decay. Where the floorboards have shrunk or been badly laid, an imperceptible current of air to the room above is the result, bringing with it a return of some portion of the palpable dust that has found its way beneath the floor, and the housewife wonders where all the dust on her furniture comes from. If the floor timbers acquire dry rot—by no means an uncommon occurrence, even in well-built houses, the initial stage often developing before wood leaves the docks—a rank fungus is the result, which spreads with alarming rapidity, and is in a high degree dangerous to health. It must be conceded that fireproof floors are to some extent a costly item in a building designed with a view to resist fire; on the other hand, it is my object to convince you that no building is reasonably safe which has wood floors and stairs, and that, on hygienic grounds alone, fireproof floors are worth the extra cost, even where cost is the paramount factor in construction. Very much less is known in a general way about fireproof floors than about most other details of building construction, and they do not possess any attractive features whatever. Nothing of a fireproof character, except brick arches, which were confined to basements and underground rooms where injury from outward thrust could be guarded against, was attempted in this country until quite modern times. This is to be accounted for by reason of suitable materials for the purpose being practically unknown a century ago. Portland cement had not been discovered, rolled iron and steel were unknown, and concrete itself—so well understood by the Romans—was not in use in this country even for foundations. In 1775 a patent was granted to Mr. Hartley for fireproofing wood in buildings by nailing thin iron sheets round floor joists and other timbers, and Parliament voted a sum of money to continue the experiments, but the result was a failure, and a little later Earl Stanhope proposed to fill in between wood joists with rough mortar laid on wood laths—what is known as pugging, and used at the present time not so much with the object of making floors fireproof as to prevent sound from passing through. Mr. Fairbairn, in his book, "The Application of Cast and Wrought Iron Work to Buildings," says the first instance of the successful application of cast-iron beams for the fireproof floors of a building was for a cotton-mill erected in 1801; the ironwork was designed by Messrs. Boulton and Watt, the cast-iron columns being entirely unprotected. Up to 1844, numerous patents had been taken out for fireproof floors, but none came to stay until Dr. Fox introduced what was afterwards known as Fox and Barrett's floor (Barrett being the business partner), and which was in use until quite recent years. Fox and Barrett's floor was very popular in London and elsewhere for many years. Mr. Wilkinson, of Newcastle, patented several varieties of floors in 1854 and later dates: one was formed with brick arches and concrete over; another was a flat arch section of Portland cement concrete, the latter possibly the forerunner of concrete arches of considerable span. Bunnett's floor, introduced in 1858, was at that

time of novel construction—viz., hollow interlocking burnt clay blocks or bricks joggling or keying each other at the joints. This principle has been practised in a variety of ways in America, but does not as yet find much favour in this country. The under side of the blocks had a dovetail groove to afford a key for the plaster, an idea which has since then been claimed as part of numerous floor patents. The floors of the Grosvenor Hotel at Pimlico are Bunnett's. Dennett's floor, introduced in 1857, is another that has been used to a very great extent. Originally it was made with plaster of Paris as the cementitious ingredient, and consisted of segmental arches up to 17ft. span, and cast-iron beams. Subsequently Dennett introduced various improvements. All the floors of St. Thomas's Hospital are Dennett's. Matthew Allen, a builder of Finsbury, brought out fireproof floors in 1862, consisting of bars of iron 3in. by 3/4in., laid edge-wise across the building from front to back, and 2ft. apart, and through which 1/2in. iron rods, also 2ft. apart, were passed and secured to the bars at the end. A temporary scaffold was fixed beneath and cement concrete was thrown in to a thickness of 4in. The floors of the Waterlow model dwellings in Finsbury are executed in this way. Mr. Hornblower, an architect of Liverpool, in 1873 recognised the danger of exposing iron beams to fire, and devised an ingenious arrangement of encasing them entirely with burnt clay or terracotta. Hornblower's floor was used for the Liverpool Corn Exchange and many other buildings. Previous to this Hornblower had employed clay tubes, or pipes, resting on the bottom flanges of the joists, and covering the latter on under side with an inch in thickness or more of concrete, a mistake which was soon rectified by others, as in Swarbrick's fireclay lintel floors. In Hornblower's tubes, Swarbrick's slotted lintols, and Bunnett's dovetail grooves we can trace the origin of tubular lintols for fire-resisting floors as used at the present time. But during the last twenty years many varieties of fireproof floors have been introduced, over 200 patents having been applied for in this country alone, but the comparatively few that have been used to any extent are divisible into not more than four types. I am not going to suggest that any floor mentioned here is superior to others; they are simply illustrations of floors in the early history of fireproof construction, and of types of others in use now. It was suggested at one time that solid wood floors would resist combustion and possess many advantages over steel and concrete. The principle proposed was to form them with deals and battens edgewise and fixed close together. This system has been practised in America, but in a paper read lately by Mr. W. L. B. Mudie, an architect, of Chicago, the author said that this principle of slow burning floors was not justified by experience, for when once a building got well alight they made a terribly intense fire. Oak is always assumed to be fire-resisting to a high degree, but Mr. E. C. Shankland, M.S.C.E., lately stated that 80,000ft.—superficial feet, probably—of oak timber was piled in a new building for the Chicago Athletic Club, and while the building was in progress a fire took place and the whole of the oak was destroyed. Silicate cotton and asbestos have both been suggested for packing between and around all hidden timbers, but the dangerous factor wood is still in existence, only waiting for a loophole to prove how difficult it is to make a building fire-resisting, yet there can be no doubt that silicate cotton and asbestos afford very great protection. But, with all their disadvantages it is pretty well agreed that steel beams and joints and Portland cement concrete, or clay tiles or lintols in combination, judiciously treated, are up to the present time the best materials we know of for forming fireproof floors, although in the United States steel beams and porous terracotta are more in favour. Flat slab floors of concrete, without beams of any kind, simply resting on the walls, have been advocated and adopted to a very limited extent; then we have steel joists fixed certain distances apart, 3ft. to 6ft. usually, and concrete filled in between level with the top flange and an inch or so below the bottom flange—other types of floors consist in imbedding iron or steel in the concrete when in a soft state; then we have arched formed floors and level ceilings, and lintol floors consisting of clay lintols resting on the bottom flanges of beams or joists, and concrete filled in over. But in selecting one or other of the systems named, or of any other form of construction, the properties of the

materials to be employed should be the first consideration. It is well known that steel beams and joists expand and buckle when exposed to heat, and that in a high temperature the loss of strength is also considerable. These are two disadvantages that can only be remedied in one way—and that is by so protecting them that it shall not be possible in domestic buildings for a fire of one or two hours' duration to injure them. By beams I mean deep single sections, or two or more sections of rolled steel forming compound beams, or riveted plate girders to carry smaller sections, which I call joists, the terms being synonymous with those used in wood-floor construction. Where beams are used, a portion usually projects below the ceiling line, and have a much larger superficial area needing protection than the joists. Moreover, they support a large portion of the entire floor, and should therefore have the greatest possible protection; but, instead of this, so far as my observation goes, the usual custom is to wedge light pieces of wood between the top and bottom flanges, about a foot apart, flush with the outside edges of the flanges, and to which metallic lathing is nailed, and this is plastered in the usual way. When the wood blocks become so hot that combustion ensues, the lathing and plastering must inevitably come away, and the beam being exposed, it is almost bound to collapse.

(To be concluded.)

HYDRAULIC v. ELECTRIC ELEVATORS.

THE relative advantages of hydraulic and electric elevators have been much discussed of late. The city engineer of Toronto, Canada (Mr. Ed. H. Keating, M.Am.Soc.C.E.), has reported on the question. As far as safety, reliability, facility of handling, and smoothness are concerned, Mr. Keating says there "is little room for choice between the most modern type of hydraulic machine and the latest improved electrical appliances—that is, the one is practically quite as safe, reliable, easily handled, and smooth in running as the other." Indeed, he seems to show that with the hydraulic elevator of the best type, operated by high duty pumps, there would be a slight advantage, as far as fuel consumption is concerned, in favour of the hydraulic system. As to which is cheaper, it is impossible to arrive at any decision until the conditions under which each is to be operated are known. As to repairs and maintenance, Mr. Keating thinks the advantage is on the side of the hydraulic plant. The question is a very important one for architects and engineers both here and in America; but it seems to us the difficulty in obtaining reliable evidence from those in charge of one system or the other precludes any satisfactory result being obtained.

ELECTRIC LIGHTING NOTES FOR ARCHITECTS.—XV.

By AN ASSOC. INST. ELECT. ENGS.

WIRING.

THE wiring of a building for electric-light purposes is a very important, and, to some extent, a distinct branch of electric-light work. It is also well within the province of the architect's work, and the following notes have been framed to assist him in this branch of his work. Having decided upon the details of distribution, the next problem is that of wiring, and it is important that the insulated conductors should be supported and fixed in a thoroughly neat and workmanlike manner, and at the same time be well protected from mechanical injury in one of the following ways:—

- (a) By being inclosed in wood casing.
- (b) By being supported in plain sight and at sufficiently frequent intervals by porcelain or wood cleats.
- (c) By being inclosed in damp-proof, fireproof, impenetrable tubes.

Whichever system is used, it will be well to remember (1) that where practicable all conductors in a building should be so placed as to be easily accessible, and capable of being thoroughly inspected whenever required. (2) That conductors should not be run out of sight, such as between floors and ceilings, inside roofs, behind skirting boards, wainscoting, &c., if it can be avoided. (3) That no conductor should be placed where it would be liable to injury of any kind, either mechanical or otherwise, nor where it

would be subjected to a temperature that might affect the insulation upon it. For interior work, no naked conductor or conductors should be allowed. Probably the most common method of protecting conductors is to use wood casing.

Wood Casing.—For high-class work the casing consists of continuous lengths of substantial hardwood (preferably the best American white-wood) 12ft. long, on one side of which two channels are grooved and separated by a fillet or width of wood not less than 1/4in. for small branch wires and 1in. for mains and principal branches. The width of the casing varies from 1 1/2in. to 6in., according to the cable used. The front is covered

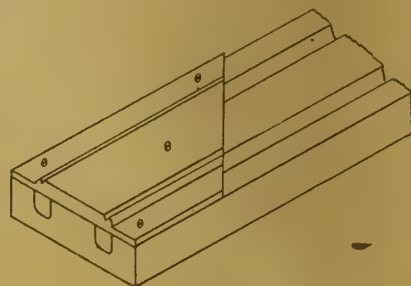

FIG. 36.

with a thin lid or covering of wood, which may be plain or ornamental, and by this means the wires are held in the grooves, and, in conjunction with the fillet, wires of opposite polarity, are prevented from coming into contact with each other. A sample of casing and covering is shown in Fig. 36. In all cases the capping of casing should be screwed on. This method is simple, and permits of the easy removal of the capping for inspection, repair, or removal of the wire if required, nails being more difficult to withdraw when it is desired to remove the capping. Both iron screws and nails should be prohibited because of the tendency to rust when placed in damp places, whilst brass screws and copper nails are not thus affected. For large casing the covers should be screwed on at the centre as well as at the sides, and for the smaller casing the capping should be screwed on at the sides only. As we have already mentioned, the width of the casing, size of grooves, and width of fillet vary according

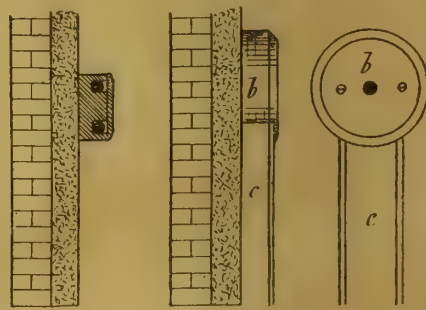

FIG. 37.

to conductor it has to carry, and we give here a short table as a guide to the size of casing to use for ordinary wires.

Size of Wire.	Casing.		
	Wire.	Size of Groove.	Width of Fillet.
18	1 1/4in.	3/16in.	1/4in.
16	1 1/2	3/16	1/4
7 20	1 3/4	5/16	1/4
7 18	2	1/2	1
7 16	2 1/4	1	1
7 14	3	1 1/2	1 1/4
19 16	3 1/2	2	1 1/2
19 14	4	2 1/2	1 3/4

In all cases it is a good plan to protect wood casing against moisture by coating it inside and out with paint, shellac varnish, or other waterproof covering. In damp places it is very essential that the wood casing be rendered waterproof, as the wood is liable to absorb moisture if this matter be not attended to. To fix the casing it is usual to mark out the run of the conductors and to plug the wall accordingly, the casing being screwed to the plugs or nailed by long French nails.

In practice there are three methods in which wood casing may be fixed. The first, known as surface work, is the cheapest, easiest to fix, and



FIG. 38.



FIG. 39.

most accessible, and may be carried out in new or old buildings. It is called *surface work*, because it is fixed on the surface of the wall as shown in Fig. 37. It is evident, therefore, that this is the

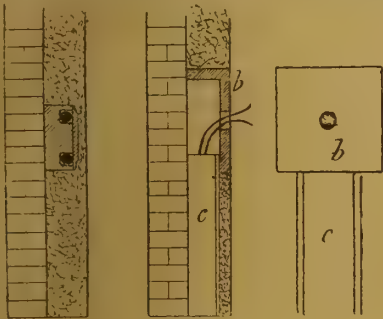

FIG. 40.

method which must be adopted when fitting premises in a finished condition, and in places such as warehouses, factories, &c., where the decoration of the rooms is not a question of importance.

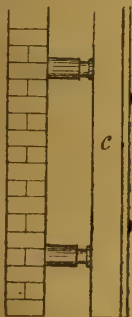

FIG. 41.

For other cases fancy moulded casing is used (see Fig. 38), and as this may be obtained to harmonise with the style of decoration, there is seldom little objection to its use.

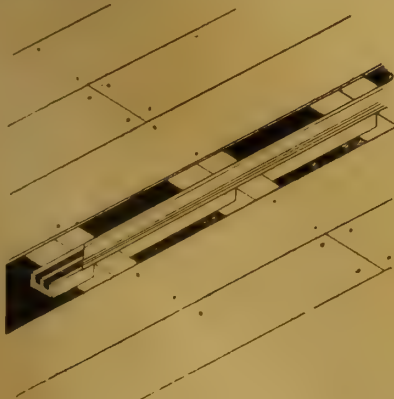

FIG. 42.

Should, however, a deep moulding be objectionable, the second method or *partially sunk work*, as shown in Fig. 39, may be employed.

In this method the casing is sunk into channels cut in the plaster, or with new premises the casing is fastened by means of plugs on to the walls, and, as will be observed, the capping or covering appears as a thin strip of moulding on the wall. This method possesses the advantage of concealing the casing, and has a neat appearance, without losing the advantages as to accessibility.

The third method, known as *concealed work*, is shown in Fig. 40, and, as will be observed, the casing is fixed to the wall before the plaster is

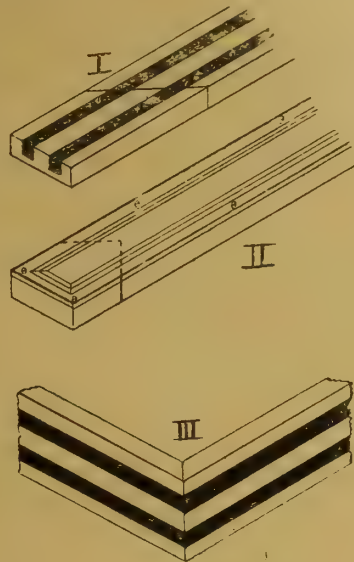

FIG. 43.

put on, the casing and capping being completely covered with the plaster. It is the method to be adopted where it is desirable to conceal the casing and covering, and can only be properly done during the construction of the premises. In some cases, such as the main branches, the size of the casing demands that the wall be grooved. The objections to concealed work are (1) the difficulty of inspecting the conductors or of making additions without disturbing the plaster, and (2) the necessity for using a larger size of casing, so that the wire may be readily drawn in or out when making repairs.

For premises in which work is done which gives rise to much dampness, as in breweries, for example, the casing is usually supported on insulators at a small distance from the walls, as

shown in Fig. 41, by which means the casing is preserved and the insulation of the circuits improved.

Whenever electroliers are fastened to the ceiling, or lamps are suspended from the ceilings by flexible conductors, it is advisable to run the casing under the floor above rather than on the ceiling itself, and in this way the casing is concealed. The method of running the casing under the floor is shown in Fig. 42. In the case shown, the casing runs across the joists, in which case the casing is sunk into the joists, and it will be observed that the casing is fixed so as to be under the centre of the floorboard which covers it. There is, then, room for the board to be screwed (not nailed, so as to permit of the board being readily taken up for inspection, repairs, &c.) on either side of the casing. If the casing be not placed under the centre, there is every possibility of wet reaching the casing during the washing of the floors. If the casing is so large that the joists would be weakened by sinking the casing, as shown, it is usual to run the casing between the joists, and to groove or bore the joists for the wires. When it is necessary to run the casing parallel to the joists, the casing should be screwed to the side of the joists. In Figs. 37 and 40, wood blocks (marked *b*) are shown; to these the switches and fittings are fastened.

It will not be necessary here to explain the methods of joining and finishing off the casing. Figs. 43, I. to VI., however, are given as a guide to those not accustomed to carpenter's work, and we may add that it is a good plan to employ carpenters to run the casing and experienced wiremen to run the conductors.

(To be continued.)

SQUARE MEASUREMENTS.\*

MUCH laborious calculation of an exceedingly irksome kind may be saved by Mr. Frank Trickey's "Tables of Square Measurements," just published by G. Pulman and Sons, of Thayer-street, Manchester Square, London, W. The volume is neatly bound, of a convenient pocket size, and is printed in clear type. Each page gives three columns of superficals, which show at a glance the number of square feet and inches in any given area from 2ft. 6in. by 1ft. 1in. to 35ft. by 25ft., advancing by inches. Mr. Trickey has found the value of such tables in the carpet trade, and others who deal in fabrics will welcome this useful ready reckoner, which will save time and insure accuracy. But the architect and surveyor, especially those who prepare quantities, will find Trickey's Tables of infinite value in the process of "squaring dimensions," by saving cross-multiplication, as well as in measuring surfaces of all kinds. For the manufacturer or salesman who wishes to make an estimate at short notice these tables will prove a great boon. Ordinary ready reckoners are only available for a few calculations; these tables of square measurement are absolutely necessary, not only to ordinary manufacturers and warehousemen, but to decorators, parquet-floor makers, and all trades in which square measurements have to be made. The price of the book is 2s. 6d.

SURVEYORS AS ARBITRATORS.

AT the ordinary general meeting of the Surveyors' Institution, held on Monday evening last, an interesting paper was read by Mr. A. A. Hudson (Associate) under the above title. The author began by saying that most surveyors were called upon at some period of their professional career to act either as witnesses in trials or arbitration for the settlement of disputes regarding building, surveying, or engineering operations. There was nowadays a strong feeling in favour of technical tribunals; but the advocates of such tribunals did not always pause to consider what would be the advantages and disadvantages of the tribunals which at present existed. Every litigant, unless he elected to go to arbitration, was entitled to have his case tried by a judge of the High Court and a jury; but when the action involved matters of accounts, it might be referred to an official referee. The very fairness of a trial before such a tribunal was frequently the cause of delay, for the judge felt bound to go into such details as would take a longer time than was

\* Tables of Square Measurement. By FRANK TRICKEY. London: G. Pulman and Sons, Thayer-street, Manchester-square.

at his disposal, and thus the case was often either compromised or curtailed. Again, a judge was bound to look upon every witness as, *prima facie*, a witness of truth, whereas, in an arbitration, the arbitrator often knew the value of a witness's evidence from personal knowledge of his practice. A judge disliked building cases because he had the task set him of reconciling what seemed to be inexplicable differences between expert witnesses, but a surveyor as arbitrator could soon resolve these discrepancies. It was for litigants to determine which procedure they preferred. If they chose arbitration, they must not complain that the relative value of their evidence could be easily weighed by the arbitrator; and if they chose trial in the High Court, they must be prepared to be cross-examined on points of credibility which the umpire would probably not have to inquire into. As to the expense, a judge received no fee from the litigants; but there were other expenses which did not occur in arbitrations. On the whole, the author thought the expenses of an arbitration were larger than those of a trial before the Court, or by an official referee. The most important element of expense and disadvantage of trials in the High Court was that parties could not arrange the trial at a date convenient to themselves, while an arbitrator was generally willing to meet their wishes in this matter. The expenses, especially in the case of country witnesses, were often very heavy when a case had to wait for the convenience of the Court, or was delayed from other causes. Again, it was frequently the case that in a matter of purely technical detail neither the judge nor the counsel concerned really understood the plans, sections, or any details of the work. These cases were in such conditions generally lost or won on small matters, due to the fact that those who had the trying of them could not, in the nature of things, have a technical knowledge of the details, and their broad bearing on the dispute. In the case of arbitrations before surveyors or architects, there could, in the first place be no question of knowledge of technicalities; but the question of the admissibility of evidence was sometimes a difficult one, and in some cases was only overcome by the appointment of a legal assessor. The converse method was for a barrister to sit as arbitrator with a surveyor or architect as assessor. There was, he thought, not much preference to be given to either method, for in effect arbitrator and assessor were really joint arbitrators. The Royal Institute of British Architects prescribed a form of contract by which, should occasion arise, an arbitrator was nominated by the President of that body, but he was not quite sure that an architect was the most suitable person to fill the position, for he was naturally a little biased in favour of his client's side. A professional man acting as often on one side as the other, seemed to be the ideal arbitrator, who would bring to the settlement of disputes the widest views and greatest impartiality. The surveyor also had a much nearer acquaintance with the value of work done than the architect, who often interested himself only in the artistic, as distinguished from the business, side of the work. As one who had, before adopting his present profession, been an architect himself, the author disclaimed any intention to reflect on the body to which he was proud to have belonged, and wished to be understood as approaching the matter from an academic point only. A building owner was very safe if he made his architect's decision final, but would be safer still if he provided that an arbitrator of his own naming should decide all matters as a condition precedent to any claim. Under the London Building Act (section 107, Dangerous Structures) the arbitrator had only to decide between two surveyors, and it would seem not to be necessary to examine witnesses on oath. Litigants wanted in the first place that their case should be understood by counsel, solicitors, and judge, or arbitrator. Next, they required a decision on their strict legal rights. Again, they wished the time of trial to be so fixed as to suit their convenience; and, lastly, they sought economy and a probability of getting their reasonable costs. The last point was often a serious one, and the costs in trials before the High Court were seldom adequately recovered. The party and party costs were taxed, with the result that at present the plaintiff generally had to pay from 2s. 6d. to 15s. to recover £1. In a case where a contractor, for example, claimed £1,000, the balance of £10,000, it was quite possible that the

quantity surveyor might have to measure the whole of the work, for which he must charge from £150 to £200. But the taxing masters did not recognise this. The Admiralty Court, which was a purely technical tribunal, fulfilled all the conditions necessary for the establishment, *mutatis mutandis*, of a court for the trial of building and engineering disputes. The procedure was simple: the date of the trial was fixed, the evidence was shortened, because experts could not give evidence on a matter within the knowledge of the assessors, and there was an opportunity, should occasion arise, of viewing the matter in dispute. This seemed to be the ideal to be aimed at in establishing a Court for the settlement of building disputes.

A discussion followed, in which Messrs. H. H. Collins, Howard Chatfield Clarke, J. Douglass Mathews, William Woodward, and J. G. Head took part, and, on the motion of Mr. P. E. Pilditch, the further consideration of the paper was deferred to the next meeting.

#### CHIPS.

The Treasury have agreed to bear the expense of casting in bronze the colossal equestrian statue, representing Energy, or Force, upon which Mr. Watts has been working for many years, and which he has expressed his wish to present to the nation. An admirable site for this has been found in Hyde Park, in the centre of the terrace at the foot of the Serpentine, and it is hoped that the statue will be placed in position with no unreasonable delay.

The directors of the Great Central Railway have let the contract for the construction of the branch railway, 8½ miles in length, from Woodford Junction on the new London line to a junction with the Great Western Railway near Banbury, and possession has been obtained of sufficient land to enable the contractors to make an active commencement at the north end of the branch.

The master builders of Selby and district have discussed the advisability of forming a Master Builders' Association and joining the Yorkshire Branch of the National Federation of Building Trade Employers. The meeting decided to form a branch of the association and to join the Federation.

A new Sunday-school and Assembly Hall in connection with the Trinity Presbyterian Church, Corporation-road, Middlesbrough, was opened by the Mayor of Middlesbrough last week. The work has been carried out by Messrs. Perks and Son, builders, Stockton.

Among the passengers on the steamship *Calabar* which left Liverpool last week for West Africa was Mr. H. B. H. Chapman, Director of the Public Works at Lagos. Mr. Chapman is to stay at Sierra Leone for a short period, to ascertain and report on the possibilities of a water supply in that colony. Captain G. H. Stone, Assistant-Director of Public Works, is also proceeding by the *Calabar* to Sierra Leone. A new gaol is being erected at Sierra Leone, at a cost of £20,000. It is situated on the Kissy road, about a mile and a half from Freetown. Waterworks are also to be constructed at Sierra Leone, and will cost that colony about £30,000. These works will be the first erected in any British colony on the West Coast.

Monifieth Dean of Guild Court has issued its decision on the petition presented by Mr. James Tullis in connection with the proposed erection of ten semidetached cottages on the part of the Golf Links recently feued by him. The Court has dismissed the petition on the ground that the provisions of the Burgh Police (Scotland) Act, 1892, in regard to the new streets have not been complied with, that the plans do not provide for the proper drainage of the buildings proposed to be erected, and that the petitioner declines to satisfy the Court in regard to these matters.

A movement is on foot for improving the western entrance of Manchester Cathedral. The object sought to be accomplished is the provision of a covered approach to the cathedral, to be used on State occasions by ecclesiastical and civil dignitaries and public bodies. It is proposed to provide a west or "Victoria" porch, and a niche has been prepared for the reception of a statue of her Majesty, to which will be added, as funds accrue, figures of notabilities in Church and State. The total outlay is estimated at £6,000, towards which Sir William Cunliffe Brooks has promised £2,000.

At the annual meeting of subscribers to the Midland Counties Home for Incurables, held on Saturday, at Leamington, it was resolved that the first section of the work of extending the institution be proceeded with, at a cost of about £3,500, by the erection of a block at the western side of the present building, whereby accommodation will be provided for 33 patients. The joint architects for the extension are Mr. W. Hawley Lloyd and Mr. W. Henman, both of Birmingham.

#### BOOKS RECEIVED.

Second editions are to hand of *Fixtures*, by SIDNEY WRIGHT; and *Dilapidations*, by A. T. MACER (London: Estates Gazette Office), both useful handbooks brought up to date.—Another volume of *Bell's Cathedral Series* is issued dealing with *Exeter Cathedral*. (London: George Bell and Son, York-street. 1s. 6d.) The compiler is Mr. Percy Adleshaw, B.A., who has produced a very readable monograph, and the illustrations are numerous and well printed.—*A History of Architecture for the Student, Craftsman, and Amateur*, by BANISTER FLETCHER, F.R.I.B.A., Professor of Architecture in King's College, &c., and BANISTER F. FLETCHER, A.R.I.B.A., Lect. on Architecture at King's College, &c. With 115 plates and other illustrations. Third edition; revised. (London: B. T. Batsford.)—We so recently noticed at some length this very useful textbook, which has already reached the third edition, that it will be sufficient to accord to it our welcome. The plan adopted by the authors, who are experienced instructors of the art, has been appreciated by those lecturers who have used the work: we mean the comparative and analytical method of treating the styles. Each style is analysed, and the parts and features contrasted, by which means the student is at once enabled to compare similar features in every style or period. Each of these is divided into five sections. The first deals with the influences which have been at work: geographical, geological, climatic, religious, &c. The second section deals with architectural character; the third gives the examples; the fourth treats comparatively of plan, walls, opening, roofs, columns, mouldings, and decoration, each of which is concisely stated, and the last section gives reference books. The plans, illustrations, colotype and others, are well selected. Professor Banister Fletcher and his son have compiled a most useful epitome of style in buildings treated scientifically, in which every important feature is taken account of, and in this respect it compares most favourably with those books which treat architecture in a more superficial manner, descriptive only of style. In this edition the authors have revised and added to the text, and given examples of Classic and Gothic mouldings. They intend to prepare a second volume treating of non-historical styles.—The last quarterly issue of the *Essex Review* (Chelmsford, E. Durrant and Co., and London, Simpkin, Marshall, and Co.), edited by Mr. E. A. Fitch, of Maldon, maintains its character as one of the best serial publications dealing with the history, antiquities, and current events of a county. Among the features of the number before us are a well-written article on the fine parish church of St. John the Baptist, Great Marton, illustrated with perspective, plans, and sketches by the author, Fred Chancellor, J.P., F.R.I.B.A., of Chelmsford; "Old Essex Deeds," by F. A. Blades; and "A Pleasant Holiday at Bradwell-on-Sea," by James Stewart.—*The Progress of Art in English Church Architecture*, by T. G. ROBERTSON, with illustrations (London: Gay and Bird). A popular and non-technical book on Gothic architecture is a worthy achievement, but one that has hitherto failed. We know of a few books of this kind; but we are not sure whether they are read. People who have a smattering of the subject, and are fond of visiting our great churches, are content with the ordinary guide-books, misleading as they are. The author of this little volume has attempted to lay before the amateur and general reader the rudiments of the subject. He deals first with the early plan of a Christian church and its symbolic signification as the very root of the subject, instead of talking about origin of Gothic art, external features, and so on, as most writers have done. The type of plan (cruciform), orientation, and the origin of the deflection of the choir are noticed, and the author refers to the Babylonish origin of orientation. The Roman worshipped facing the east, as the Greek before him did toward the west. The early Christians also always prayed facing the east, and the author repeats the tradition that some churches were built to point to the sunrise on the days of saints to which they were dedicated. Several typical plans, as those of Westminster, York, Wells, Amiens, are illustrated. The subsequent chapters deal with crypts, their origin as safe places for relics; the Revival of Gothic Art, in which Rickman's "Nomenclature of Styles" and Sharpe's "Classification into Seven Periods" are spoken of. The characteristics of the Norman, Early English, Decorated, and Perpendicular periods are described

by the aid of suitable diagrams and sketches, and chapters are added on "Notes on English Cathedrals," Scottish churches, also the difference of the Renaissance, and some remarks on a new style. The few notes on "Mason's Marks" are useful. The illustrations and sketches in some cases are scarcely up to the mark; but Mr. Robertson's manual will be found of service to the general student, who wishes to master the principles of the subject. There is a good index.

### CHIPS.

The Redruth Union Infirmary is being warmed and ventilated by means of Shorland's patent double-fronted Manchester stoves with descending smoke-flues, the same being supplied by Messrs. E. H. Shorland and Brother, of Manchester.

The Great Central Railway Company have deposited a Bill for next Session, by which powers are sought to construct 7 miles 2 furlongs of new railways in Middlesex, Nottinghamshire, and Derbyshire. Of these railways, over 6 miles are proposed to be constructed in Middlesex so as to enable the company to connect their line, now in course of construction through Willesden, with the Great Western Railway Company's line authorised last session through Ruislip. The remaining four projected lines are all under four furlongs in length, and form merely junction railways in Kirby-in-Ashfield, Worsop, and South Normanton.

The Old Kilpatrick School Board have just completed the erection of a public school in Elgin-street, Yoker, and it will be formally opened by Lord Overton next week. The school will accommodate about 1,200 scholars.

The Lerwick School Board received at their last meeting a report, with relative sketch plans, from Mr. Wilson, architect to the Edinburgh School Board, with reference to proposed enlargements of the present school accommodation in Lerwick. Some time ago Mr. Wilson visited Lerwick, and now submitted alternative plans. One of these provides for the erection of a new school on the site of the present central school, the whole buildings and teacher's house on which site would be demolished. The estimated cost is £4,300. It was also proposed to erect an addition at the back of the Anderson Institute at a cost of £1,400—in all, £5,700. The alternative plan provides for a smaller school on the central school site, and larger additions at the institute, the cost being the same. The meeting remitted the plans to a committee for report.

A Jubilee clock tower is about to be added to Kingswood Church, near Bristol, from plans by Mr. C. Mackay. The tower will rise from the ground, and will be of brick with stone dressings, and three dials, each 5ft. 6in. in diameter, will be provided.

It has been decided that the proposed memorial to the late Dean Montgomery, of Edinburgh, shall take the form of a recumbent effigy in marble, to be placed in St. Mary's Cathedral. The work is estimated to cost £1,000.

In addition to the £3,600,000 additional capital which the Midland Railway Company are seeking power to raise under a Bill for power to construct over thirty miles of new railways in Yorkshire, a second Bill has also been deposited by the same company for power to raise a further £2,000,000, which will be principally expended in the construction of over twenty-one miles of widenings on portions of their railway from Leeds to Skipton, Leeds to Bradford, Derby to Leeds, Sheffield to Leeds, Chesterfield to Sheffield, Birmingham to Derby, Leicester to Peterborough, and at East Wigston in Leicestershire. These widenings will include an enlargement of their station at Sheffield.

A mural family memorial tablet of a novel character in the north has recently been placed in Fyvie Church Aberdeenshire, by Miss Chalmers, of Monkshill. Wholly executed in champlevé enamel, the tablet is about 3ft. in length by 2ft. in breadth—a large size for firing in one piece. The ornamental border is in blue and green, the body of the tablet has a golden ground, on which the lettering of the inscription appears in blue, black, and red, and there are three decorative initial letters in different colours. The tablet was designed by Mr. Pittendrigh MacGillivray, A.R.S.A., of Edinburgh.

The extensions at Meadow-lane gasworks, Leeds, which have cost over £30,000, are now nearing completion, and the new inclined retorts, which represent a further expenditure of £22,463, are expected to be ready for use about May. These new retorts will enable the gas committee of the Leeds Corporation to increase the output from the Meadow-lane works from  $\frac{1}{2}$  million cubic feet a day to over seven million cubic feet. The introduction of these mechanical stoking appliances will also cheapen the production as well as relieve the workmen of much wearisome labour.

## Engineering Notes.

CITY AND SOUTH LONDON RAILWAY COMPANY.—The report for the half-year ended December 31 states that since the last report very satisfactory progress has been made with the extension to Finsbury-pavement, but the works necessary for upholding the fabric of the church of St. Mary Woolnoth have caused considerable delay at that point. The difficulties have, however, been nearly overcome, and more rapid progress there will now be possible. Considerable progress has been made in the acquisition of the sites for the stations on the Clapham extension, and it is hoped very shortly to let the contract for the completion of that portion of the line. In order to utilise the portion of the present line between the Borough Station and King William street, which will be thrown out of use by the construction of the new extension, arrangements have been made with a new company, the City and Brixton Railway, to continue this part of the line from the Borough, *via* St. George's-circus, and Kennington-road, to Brixton-hill, and it is proposed that the new line, when completed, should be leased to and worked by the City and South London Company in conjunction with its present system. Provisional arrangements have been made for the construction of a subway to connect the platforms of this company's station at Lombard-street with those of the Bank Station of the Central London Railway, at the joint cost of the two companies. A Bill has been deposited by the directors the principal purpose of which is to obtain an extension of time for the construction of the line to the Angel, at Islington, authorised by the Act of 1893, and to authorise a short additional siding at Clapham-common, rendered necessary in connection with the station there.

It is proposed to erect, by subscription, a statue of the late Duke of Devonshire at Eastbourne, of which as a fashionable watering-place he was the founder.

The new post-office, Forfar, is approaching completion. It has a frontage to Castle-street of 40ft. and extends back 116ft. On the street floor is the public office, 20ft. by 20ft., and behind it are the post-master's room and sorting office, the latter being 42ft. by 24ft. At the rear of the building the telegraph lineman's room and battery room are situated, together with the barrow shed and basket store. On the first floor are the telegraph instrument room, 20ft. by 16ft., telephone room, 12ft. by 11ft., and boy messengers' room. Mr. David Adamson, Yeaman-street, Forfar, is the principal contractor.

The Light Railway Commissioners have issued a draft order for the construction of a light railway from Postland, in Lincolnshire, to Peakirk, in Northamptonshire. The railway, which is for the benefit of the Crowland district, is to have a junction with the Great Eastern Railway at Postland, on the Spalding and March line, and with the Great Northern Railway at Peakirk, on the Peterborough and Spalding loop line. It is to be of the ordinary gauge. Hitherto, Crowland, famous for its abbey and unique triangular bridge, has had no direct railway communication, Postland, the nearest station, being five miles distant. The capital is fixed at £45,000.

A recent memoir of the Geographical Survey of England and Wales, dealing with soils and subsoils from a sanitary point of view, has been published by order of the Lords of the Treasury. Sir Archibald Geikie, Director General of the Survey, states that inquiries are constantly being made by the public for advice regarding the nature of the soils and subsoils of sites upon which house-building is contemplated. Accordingly, Mr. Horace B. Woodward, F.R.S., was instructed to prepare a treatise upon the subject, with especial reference to London and its suburbs.

The Mercers' Company and the Gresham Committee are having a niche prepared on the south wall of the ambulatory of the Royal Exchange for another mural decoration. This will make the fifth of the eight works which different donors have already promised. The subject of the new panel is an historical episode, "The Opening of the Royal Exchange by Queen Elizabeth, on horseback." The painting is the gift of the Mercers' Company, and the artist is Mr. Ernest Crofts, A.R.A. There are still twenty panels to be filled with subjects of historical events. The pictures are all painted in spirit fresco, a method invented by Messrs. Charles Roberson and Co. The colours ground in this medium are used in a similar manner to ordinary oil-colours on a specially prepared, highly-absorbent canvas which, when the picture is finished, is laid solidly on the wall.

## Building Intelligence.

BATTERSEA.—The new municipal workshops which have been erected by the Battersea Vestry were formally opened on Saturday afternoon. The principal block covers a space of 280ft. by 25ft., and is built in two stories. On the ground floor there are a joiners' machinery department, an engine-room, a wheelwrights' shop, a forge for smiths and farriers, a harness-makers' room, and a painters' room. On the upper floor there is a joiners' shop, which has 12 benches, and lantern lights in the roof as well as side windows; a vanbody-makers' shop, and also departments for plumbers and smiths and fitters. Connected with the vanbody-makers' shop there is a lift which raises 30cwt. from the ground floor. The machinery includes circular-saw benches, a band saw, a planing machine, a copying lathe, a buffing machine for sand-papering the spokes, and a general wheelwright. There is a turning-lathe 14ft. long, a metal-drilling machine, a saw-sharpening machine, a mortise and boring-machine, a screw-cutting lathe, and a variety of other machines as well. The forge is a shop 50ft. long by 22ft. wide, where one finds at each end a patent self-contained blacksmith's forge, with cast-iron hearth and hood forming one piece, while in place of the familiar bellows there is a blast produced by means of a fan. The motive power for working all this machinery is supplied by an Otto silent gas-engine of 25H.P. The total cost of workshops and machinery is £8,000, but it is estimated that henceforward a saving of 10 per cent. will be effected by the vestry on all the work it does. The workshops were designed by the vestry's surveyor, Mr. J. T. Pilditch, and they are now in charge of the superintendent of works, Mr. Thomas Sheppard, who also looks after the whole of the men employed by the department, some 800 in number.

BIRKENHEAD.—A new Liberal club in Duke-street was opened on Friday by Mr. Asquith, M.P. The building up to the first floor level is of grey bricks, relieved with red pressed Ruabon bricks, and terracotta. From the moulded string-course up to the eaves the walls are finished with hand-set spar in cement. To the right of main entrance-hall is the staircase to the assembly-room. On the left is the smokers' room and reading-room. Directly opposite the entrance are doors leading into the billiard-room, and at the rear, on the ground floor, are the lavatories, committee-room, and back entrance. In the basement are the kitchen and heating-chamber. A mezzanine floor contains a ladies' and gentlemen's cloakrooms, lavatories, &c. On the upper floor is a hall capable of accommodating 400 people—platform 20ft. by 13ft. 6in., and retiring rooms on each side of stage. The building will be heated by low-pressure hot-water pipes, and the incandescent light will be used. The sole contractor is Mr. George Snape, Birkenhead, and the designs are by Mr. T. Taliesin Rees, of the same town.

CHART SUTTON, KENT.—Upwards of a century has passed away since the parish church of Chart Sutton was destroyed by fire. In the year 1779, a thunderstorm, passing over the Weald of Kent, struck and ignited the spire of this church. Being of wood, the spire quickly fell on to the nave, and the church was all but demolished, the tower only remaining. The present inexpensive building was then erected, and hitherto had consisted of a nave only, the chancel and aisles of the old structure not having been rebuilt till the present time. The new chancel was dedicated on Saturday last. The work of restoration, which is being carried on by Messrs. James Wood and Son, of Boughton and Chart Sutton, comprises, in addition to the new chancel, vestry, and organ-chamber, several improvements to the nave. The internal walls are to be faced with stucco. The outlay will be £1,700.

KING'S HEATH.—The new Wesleyan church in Cambridge and School-roads, King's Heath, Birmingham, was opened on Friday last. The building, which is 80ft. long by 49ft. wide and 42ft. high, is divided into nave and aisles by three wide arches on each side, supported by red Aberdeen granite piers, with stone caps and bases. A transept projects on each side about 4ft. beyond the aisle walls, one transept being arranged for the organ and choir stalls, and a raised chancel, 18½ft. by 11½ft. deep extends beyond a moulded chancel arch, supported on

grey Aberdeen granite shafts, having moulded and carved caps and corbels. The floor is paved with encaustic tiles, and a high dado of glazed tiles covers the lower part of the walls. The east wall of the chancel has a five-light window, having a 12-light wheel in the upper part. This window has, at the sole cost of Alderman Bowen, who has carried out the building of the structure, been filled with stained glass from the studio of Messrs. Camm and Co., Smethwick. The pictures represent "The Last Supper," "The Nativity," and "The Ascension." The twelve lights of the "wheel" surmounting the three windows contain emblems of the twelve tribes of Israel, with a representation of angels attending the Saviour forming the centre. Below the window is an arcaded reredos, containing the Lord's Prayer, the Ten Commandments, and the Creed in letters of gold. These also are the gift of County Alderman Bowen. At the west end of the church is a gallery, backed by a window of tinted glass. The exterior is of red terracotta and brick, and the church has a spire. The general style adopted by Mr. William Hale, architect, is based on the Early English period. The woodwork generally is of pitchpine. The cost of altering the existing building and erecting the new structure has been £6,000.

**LEEDS.**—The Standard Life Assurance Company are about to erect a large block of buildings on the site of the old post-office in Leeds. The company recently purchased the site from the Corporation for £49,950, and acquired the property at the rear with a frontage to Wine-street for £11,000. The preparation of the plans of the new buildings has been intrusted to Mr. Archibald Neill, 18, Cookridge-street, Leeds, and the work will be carried out under his supervision. The design is Classic in character. The façade will be of stone, Bolton wood in the basement, and the remainder Portland. Internally, the accommodation will comprise between forty and fifty suites of offices. All of these, with the exception of about four suites, will be lighted from the front, which faces south. The main entrance to the building will be from City-square; the offices facing Park-row will have separate entrances. The basement will have an entrance at the lower side of the site. The various stories will be reached by an elevator as well as by staircases. Every apartment in the building will have its fireplace. Mr. Isaac Gould is executing the contract for the digging of the foundations, and building operations will ere long be commenced. The estimated cost of the structure is about £30,000.

**NEW BRIGHTON.**—The New Brighton Tower, the highest spire in the United Kingdom, has just been brought to completion. The height from ground level to the burnished copper ball on the top of the flagstaff is 567ft., whereas the next loftiest structure—the Tower at Blackpool—rises to a height of but 518ft. 9in. The chimney at the St. Rollox Chemical Works, Glasgow, is 486ft. high, and the spire of Salisbury 404ft. The loftiest, of course, falls far short of the Eiffel Tower at Paris, which, it will be remembered, is 984ft. from ground level to summit. The tower at New Brighton is octagonal on plan, standing on eight legs, the base being 150ft. across. It is constructed of British mild steel, the weight of materials being 1,760 tons. The setting-out of the tower site was fully illustrated in our last volume. The architects and engineers are Messrs. Maxwell and Tuke, of Manchester, Messrs. Handyside, of Derby, were the contractors, and Mr. John Ashley, who was employed on the Blackpool Tower, was the clerk of works. At the base of the structure is a block of buildings some 90ft. in height now approaching completion. In this block is a theatre seated for 3,000 persons, and over this a concert and ball-room, a third floor, which has a glass roof, being arranged as a winter garden. The lifts are worked by electrical power generated at a station in the grounds.

**PAISLEY ABBEY.**—An organised and determined effort is about to be made to restore the whole of Paisley Abbey. In 1862 the nave, which, though in a dilapidated state, had been used as a place of worship by the parishioners, was, after considerable expense, repaired and beautified. The transept and choir are partly ruinous. They are roofless with only their walls standing. Shortly before the Reformation the central tower, which had been built by the last Abbot of Paisley, also the last archbishop of the old church, fell from being insufficiently founded, and crushed in the

choir and transept in its fall. The present movement to build up the ruinous part of the church has been promoted, in the first instance, by the congregation worshipping in the western portion, who have offered to subscribe £10,000 towards the scheme of restoration. Large subscriptions have been promised, and the scheme often mooted is likely at last to be seriously undertaken. Dr. Rowand Anderson, of Edinburgh, is the architect.

#### CHIPS.

An appeal is issued by the Dean of Gloucester for funds to add a solo organ to the instrument in Gloucester Cathedral, and some necessary stops. When the organ was restored in 1839, space provision was made for the desired addition, which can be made without altering the appearance or position of the organ. A sum of £650 is required to carry out the work. The original organ was built by Renatus Harris in 1662, and some of the stops were included in the recent restoration.

It was reported at the last meeting of the town council for Burton-on-Trent that the late borough surveyor, Mr. Swindlehurst (now the Coventry city surveyor), had presented a claim for £150 for service rendered in connection with his superintendence and control of the corporation contracts between June 9 and August 3. This was referred to a committee, who now recommended the payment of £63 in full settlement of the claim. The recommendation was agreed to unanimously.

Another arcade is about to be constructed in Leeds. It will extend from Lands-lane into old property at the rear, a distance of 64ft., then branch at right angles towards Upperhead-row, a distance of 162ft. Thus a new way will be available from Woodhouse-lane into Briggate. On the right and left of the new avenue will be shops—25 in all. Most of them will have a workroom or showroom over. The architects are Messrs. Ambler and Bowman, of Park-place, Leeds.

Sunday-schools are about to be added to Christ Church, Waterloo, Liverpool, from plans prepared by Messrs. Fry, Liverpool. The schools will be built of brick, on a site between Crosby-road and Sandringham-road, at a cost of £3,000 or £3,500.

A new Wesleyan chapel is being built in Cardigan-lane, Burley, Leeds. The estimated cost is £5,500. It is intended in a year or two to erect a Sunday-school adjoining. The architect is Mr. G. F. Danby, of Great George-street. From designs by the same architect, another chapel is being erected in Ladypit-lane, Holbeck. The cost will be about £1,100.

St. Michael's Roman Catholic Church, Abergavenny, has recently been enriched at the cost of Mrs. Ralph Clutton. Some years ago four of the lights of the large east window were filled with figures of the Blessed Virgin Mary, St. Joseph, St. Benedict, and St. Scholastica, the two outer lights and the tracery being left in the ordinary glass. Mrs. Clutton determined to complete the lights by the addition of the figures of St. Thomas of Canterbury and St. Margaret of Scotland, and as, since the original lights were erected, a stone reredos had been put into the church which destroyed the arrangement of the design of the glass, she has met the cost of altering the existing glass to suit the circumstances, as well as to defray the cost of the two new lights. The execution of these additions and changes was intrusted to Messrs. John Hardman and Co., of London and Birmingham.

The third extension, just finished, of the Southport Corporation Electric Works, brings up the capacity to fivefold what it was when, but three years since, the works were inaugurated. A fourth extension has been already set afoot, but even this will hardly overtake the estimated demand for next winter. The recent addition to the plant is a dynamo of the "ironclad" type, the alternators being placed on the periphery of the flywheel. The new dynamo is driven by a 500H.P. engine, and can supply 10,000 8c.p. lamps at one time, thus raising the total of the installation to 22,750 8c.p. lamps. The cost to date of the electric works has been £60,000, and the extension just commencing involves £21,000 more.

The experiments for the bacteriological treatment of the sewage of Oswestry, initiated some months ago by the borough surveyor (Mr. R. O. Wynne Roberts, C.E.), have attracted visits to that town by representatives of the sanitary authorities of Tarvin, Harrow, Wrexham, Lincoln, Hexham (urban and rural), Congleton, Nantwich, Chester (rural), Malpas, Morecambe, Aitcham (rural), Hereford (county), Brooklyn, N.Y., &c.; and deputations from West Kirby, Wakefield, and Hamburg are expected to visit the works in a few days. The deputation from Hamburg, which will visit the works to-morrow (Saturday), will consist of the chief engineer, the assistant engineer, the chief M.O.H., the Port M.O.H., and Mr. H. A. Roehling, of Leicester.

#### COMPETITIONS.

**BUSHEY.**—A limited competition was held for the Royal Masonic Centenary Schools for boys about to be built at Bushey, and on the award of Mr. Rowland Plumbe, has been settled in favour of Messrs. Gordon, Lowther, and Gunton, architects, Finsbury, E.C. The cost will be about £100,000. Designs were submitted, we understand, by Mr. Alfred Waterhouse, R.A., Mr. Aston Webb, F.S.A., Mr. Basil Champneys, M.A., and Mr. John Morley, of Cambridge. Sir Arthur Blomfield, A.R.A., was invited, we are told, but declined, and the late Mr. C. J. Shoppee died before the competition came off.

**GILLINGHAM.**—Plans by Mr. Fredk. Smith, architect, Bank Chambers, High-street, New Brompton, Kent, have been adopted by the Gillingham Urban District Council, in a limited competition for extensions to their present Technical Institute. The estimated outlay is £1,600, the additions consisting of new cookery school, manual instruction-room, and three large class rooms.

**WEST BANGOUR.**—The Edinburgh District Lunacy Board have invited architects to submit competitive designs in connection with the establishment of a lunatic asylum which they propose to build on the estate of West Bangour, in the parish of Ecclesmachan, Linlithgowshire, about two miles west of Uphall. It is intended, in the mean time, that accommodation will be provided for 600 patients, though suitable provision will be made for extensions whereby 1,000 will be accommodated. Only architects in Scotland who have been in practice on their own account for not less than two years will be permitted to compete. The architect selected by the board will be employed to carry out the work at the rates of remuneration and under the conditions contained in the schedule sanctioned by the Royal Institute of British Architects. If from any cause the buildings are not proceeded with, and no drawings other than the competitive drawings have been prepared, the selected architect shall receive a payment of £500 in full of all claims. In respect of the other competitive designs, four premiums will be paid in the following order:—£250 to the author of the design adjudged to be best by the architectural assessor; £200 to the author of the design placed second; £150 to the author of the design placed third; and £100 to the author of the design placed fourth. The board desire that the buildings should be of the most substantial description, and pleasing in character, but they do not wish that any considerable expense should be incurred in mere ornamentation.

At the Congregational Church, Shaw, Lancs, a new organ of 652 pipes, built by Messrs. A. Young and Sons, of Manchester, was opened on Wednesday week.

The new cemetery, which is to be purchased by the Huddersfield Corporation at Lockwood, will cover an area of over 22 acres. The land has been known as the Woodfield House Estate, and the purchase price is £4,750, including the buildings thereon, or 10d. per freehold yard.

According to the directors' last half-yearly report, work on the Bengal-Nagpur Railway extensions has been carried on vigorously. The rails have been laid from Sini, on the open line, to Midnapur, 99 miles, and from Kola, on the right bank of the Roopnarain, to the Subanarika river, 82 miles. The important bridges over these rivers are being pushed on as fast as possible.

A meeting of employers connected with the building trade was held in the Albert Hall, Morecambe, on Tuesday in last week, for the purpose of considering the advisability of forming a masters' association with a view of protecting their interests. Addresses on the advantages of federation were given by Mr. Tomlinson (Fleeton), secretary of the Lancashire Federation; Mr. Gartside (Chorley), and Messrs. Parker, Kidd, and Sharples (Longridge). After some discussion, it was decided that an association be formed, and a committee, consisting of Councillors J. Scott, J. H. Brear, J. Gardener, and Messrs. J. Euolme and A. Woodhouse was appointed to draw up rules.

About £14,000 is being spent on the rebuilding of Oxford-place Wesleyan Chapel and Sunday-school, Leeds. The front and one side of the old chapel have been taken down and replaced by more attractive elevations. This work has been carried out without closing the chapel. Not so the old Sunday-school, which has been demolished. The new school is nearing completion, and will be ready for occupation about May. Mr. G. F. Danby, of Great George-street, and Mr. W. H. Thorp, of Albion-street, both of Leeds, are the joint architects.

CONTENTS.

Instructions to Architects .....	115
Building Nomenclature .....	115
Royal Institute of British Architects .....	116
Reference Books on Ornament and the Decorative Arts .....	118
Fireproof Construction of Domestic Buildings .....	120
Hydraulic v. Electric Elevators .....	122
Electric Lighting Notes for Architects.—XV. ....	122
Square Measurements .....	123
Surveyors as Arbitrators .....	123
Books Received .....	124
Engineering Notes .....	125
Building Intelligence .....	125
Competitions .....	126
The BUILDING NEWS Directory .....	ix.
Our Illustrations .....	127
Architectural and Archaeological Societies .....	146
Correspondence .....	147
Intercommunication .....	147
Legal Intelligence .....	148
Statues, Memorials, &c. ....	148
Water Supply and Sanitary Matters .....	148
Our Office Table .....	149
Meetings for the Ensuing Week .....	149
Trade News .....	149
List of Competitions Open .....	150
List of Tenders Open .....	150
Latest Prices .....	153
Tenders .....	153

ILLUSTRATIONS.

NEW OFFICES FOR MESSRS. RECKITT AND SONS, LIMITED, AT HULL.—CHAPEL, SEDBERGH SCHOOL.—NEW CHURCH, FLOCKBURGH.—THE FABLE OF "THE FOX AND THE CROW."—HOUSE NEAR HAWICK, N.B.—BUCKINGHAM PALACE MANSIONS, S.W.—BROMLEY COLLEGE, KENT.

Our Illustrations.

NEW OFFICES FOR MESSRS. RECKITT AND SONS, LIMITED, HULL.

THIS new block of offices, &c., is now in course of erection in Danson's-lane, Hull, adjoining the extensive starch and blue works of Messrs. Reckitt and Sons, Limited, having a frontage of 140ft. to Danson's-lane and 80ft. to Starchhouse-lane and New Parade respectively. The ground plan shows principal entrance from Danson's-lane leading into a spacious waiting-hall and a general office, 89ft. by 32ft. and 18ft. 6in. high, surrounded by the boardroom, private offices, cashiers' offices, auditors' room, travellers' waiting-room, type-writing-room, and clerks' dining-room, the latter arranged so that it can be added to general office accommodation when required. The strong-room, 31ft. by 14ft., and stationery-room, 14ft. by 10ft., are connected with general office by a short corridor. There is an entrance at the rear giving easy access to general office from the works. On the first floor a large dining-hall, 90ft. by 48ft., 13ft. high, is arranged for the use of the workpeople, with the necessary kitchens, &c., and is approached by separate staircase for men and women from the back road. The second floor, also the attic floor, is to be used for warehouse purposes. The buildings will be faced with red Ruabon bricks and Howley Park and Ancaster stone dressings, and roofed with green slates. The walls of strong-room will be faced inside with white glazed bricks. The inside lavatory walls will be tiled in plain tiles, while the walls of waiting-hall will be faced with faience. The inside joiners' work will be executed in pitch-pine, but the entrance-hall and boardroom will be fitted up in mahogany. The floor of general office will be in wood blocks, while the waiting-hall and lavatory floors will be laid in mosaic. The back staircases will be built of solid stone steps and landings. The buildings will be lighted by electricity. The work is being carried out by the following contractors:—Brickwork, Mr. Benjamin Nicholson; masonry, Mr. G. H. Panton; carpenter and joiners' work, Messrs. Darneley and Son; slating, Messrs. Wilde and Son; plumbing and glazing, Mr. F. Oldfield; painting, Mr. G. Porter—all of Hull. The whole under the supervision of the architects, Messrs. Gelder and Kitchen, of 76, Lowgate, Hull.

THE SCHOOL CHAPEL, SEDBERGH, YORKS.

THIS chapel is designed with a continuous nave and chancel without a chancel arch, which is somewhat a feature of the churches of Craven. The long line of roof is broken by a bell-turret of oak covered with lead, and the roofs are covered with stone slates. The nave is 82ft. long and 25ft. wide, and chancel 33ft. by 25ft. The arcades are low, with segmental arches, and fine square-headed windows in clerestory over;

narrow aisle passages give access to seats at sides. The fine organ is contained in the north transept and aisle, there being a similar transept on south side seated for masters' families, &c., with choir and clergy vestries on east side. Local stone, with Prudham stone dressings externally, has been used, the interior facing being of flecked red Runcorn; pitch-pine roofs, and oak seats and fittings; wood block floors, flagged passages, and porches; chancel floor tiled. The sole contractors are Messrs. Brassington Bros. and Corney, of Settle. The architects are Messrs. Austin and Paley, of Lancaster.

FLOCKBURGH CHURCH

Is in the Early English style. It will consist of nave, 69ft. long by 22ft. 10in. wide; tower at west end, 26ft. 6in. by 25ft. externally, and 53ft. high, top of parapet. North and south aisles and organ transepts; at the east end of chancel will be a semicircular apse with stone groined roof. Advantage has been taken of the sloping site to form a vestry and heating cell under the apse and transept; access to chancel by north and south tower doors. Materials are for walling of local stone with Prudham dressings, in broken courses inside and out, except inside of apse, which will be ashlar. Roofs covered with stone slates, except aisles and apse, of lead. Roofs of pitchpine and seats of oak, wood block floors, and passages flagged; chancel tiled. Contractors: Masonry, A. Blair, of Allithwaite; carpentry and joinery, Messrs. Gradwell and Co., of Barrow-in-Furness; slater, J. Chippendale, of Grange; plumber and glazier, A. Moorhouse, of Kirkby Lonsdale. The architects are Messrs. Austin and Paley, of Lancaster, who are doing the work for Mr. Victor Cavendish, M.P., of Holker Hall.

STUDIES OF ANIMAL LIFE TREATED FOR DESIGN: "THE FOX AND THE CROW."

LIKE the previous illustration, given on Jan. 7, these studies were made with a view to decorative design. They assist in the ornamental rendering of "The Fox and the Crow" in linen damask. The drawings were made from the magnificent collection in the Natural History Museum at South Kensington. While it probably would have been more correct to have studied the Jackal as being the animal intended in the original fable, the common English fox was thought more in accord with the prevailing conception of the tale. Not only has the general outline in the different positions and the colour been rendered with a view to this purpose, but close attention has been given to the details, as will be seen in the drawings of the eyes, feet, &c., as well as the varying direction of the hair of the fox. These studies were awarded a silver medal in the national competition at South Kensington in 1897. They are examples of studies intended solely for use in designs, and not in any sense paintings of the animals, &c.; the contours and interior markings are distinctly defined, and the peculiarities of colour laid on in flat washes to diagrammatically represent the delimitations of each tint, and not to exhibit the light and shade.

HOUSE NEAR HAWICK, N.B.

THIS house is situated about three miles above the town, on the right bank of the River Slitrig. The house, which stands considerably above the river, and commands fine views both up and down the valley, is built of whinstone, rough-cast on the exterior, with red Moat stone dressings to the windows, doors, gables, &c., while the roofs are covered with Tilberthwaite green slates. In accordance with the hilly nature of the site, the kitchen and offices are placed in the basement, with entrance on the north side, while the main floor (of which a plan is annexed), enters from the more level ground to the south. The upper floors are devoted entirely to bedroom accommodation: besides the usual fireplaces, the house is heated throughout with radiators. A lodge has also been erected at the entrance to the grounds, together with stabling and coachhouses, and a bridge over the river. The architect is Mr. James P. Alison, of Hawick.

BUCKINGHAM PALACE MANSIONS.

The illustration shows the perspective view of this block of residential flats and shops, which occupies a very magnificent position with a frontage to James-street, Buckingham Gate, Westminster. The building is faced with T. L. Laurence's red bricks, and Portland stone dressings. The carved brickwork (by Mr.

Gilbert Seale) and the roofs are covered with green slates, and the dormers are in copper. The contract for the building (exclusive of the decorating and electric lighting), has been let to Mr. J. J. Hall, contractor, of Dover, for £21,000, and Mr. Charles James Chirney Pawley, of Westminster, is the architect.

BROMLEY COLLEGE, KENT.

THIS is a charitable institution, founded by John Warner, Bishop of Rochester, in 1666, for twenty poor widows of clergy. The original building (as shown on the sketch plan) consists of rooms arranged round a quadrangle with a covered way. A second quadrangle was added in 1794—1805, providing accommodation for twenty more widows, thus bringing the total number up to forty. The chapel in the central part was rebuilt about thirty years ago, and has no architectural interest. The main front, forming the subject of these drawings, is the only part that contains much detail. The wings projecting forward form residences for the treasurer and chaplain, and the stone archway in the centre gives access to the quadrangle, although there are side entrances as well. It is said that the bricks used in the old buildings were brought from London (8½ miles distant) after the Great Fire, and they have weathered a deep red; they run about four courses to the foot. All roofs are tiled. The dormer windows are modern; the other windows are casements with transoms and mullions, and are extremely plain in detail. The buttresses, an unusual feature in buildirgs of this style, are only used in the old college. Tops and set-offs are moulded. The eaves-course is continued round the outside of the whole building, but dentils occur only along the front and for 40ft. on each side. It is of wood, covered with lead, and has a modern iron gutter partially hiding the top members. The front doors and windows, on the return of the wings to the chaplain's and treasurer's houses, have external wooden painted architraves, with stone steps and projecting wooden hoods. The central archway is of Portland stone, and the entrance gate, of iron with stone piers, opens on to Bromley High-street. The inscription over the archway in centre is as follows:—

DEO ET ECCLESIE

This College for Twenty poore Widdowes (of Orthodoxe & Loyall Clergymen) & a Chaplin was Given by John Warner late Ld Bishop of Rochester 1666.

—R. H. ERNEST HILL.

The widening of the London and South-Western Railway main line from Woking to Basingstoke has commenced, and the first section of the work from Short Lane to Farnborough is now in hand.

A stained-glass window has been placed in the west end of Yarpole Church, Herefordshire. The subject of the central light is "The Good Shepherd," and in the side lights are depicted "St. Cecilia" and "Charity." The artists are Messrs. Jones and Willis, of London and Birmingham.

The Young Men's Christian Association Institute in Gateside-street, Hamilton, N.B., was opened last week. The institute, which is a three-story building, and erected to plans by Mr. Alexander Cullen, F.S.A., Hamilton and Motherwell, contains on ground floor a hall, committee-room, and cloakrooms; and on the first floor reading-room, library, and caretaker's house; while the upper flat is to be let as dwelling-houses, disconnected with the Association rooms. The cost has been £1,600, not including furnishings.

The Bishop of London has expressed his readiness to preach at the dedication of the Monk Memorial Chapel, St. Matthias, Stoke Newington. The south chancel aisle is now in process of embellishment by Mr. D. Bell, and will, it is hoped, be finished by the anniversary of Dr. Monk's death. The cost of this memorial is borne mainly by one generous layman, who also presents a costly reredos.

Last week a new spire to the parish church of Greatham, Hants, was dedicated by the Bishop of Winchester. This addition is the gift of the owner of Le Court, Mr. Heath Harrison, in order to perpetuate the Diamond Jubilee of the Queen. The new spire represents an addition of about 70ft. to the tower at the eastern end of the church, which is now rather more than 100ft. high. There are four two-light belfry windows, with slate lappers, Gothic heads, carved bosses and columns, and the masonry has been built of Selborne stone with Bath stone dressings. The spire is built entirely of English oak covered with oak boardings and shingles. The plans were prepared by Mr. F. Chancellor, of Finsbury Circus.

BROMLEY COLLEGE: KENT.

PRINCIPAL FRONT: 1666

SCALE OF FEET

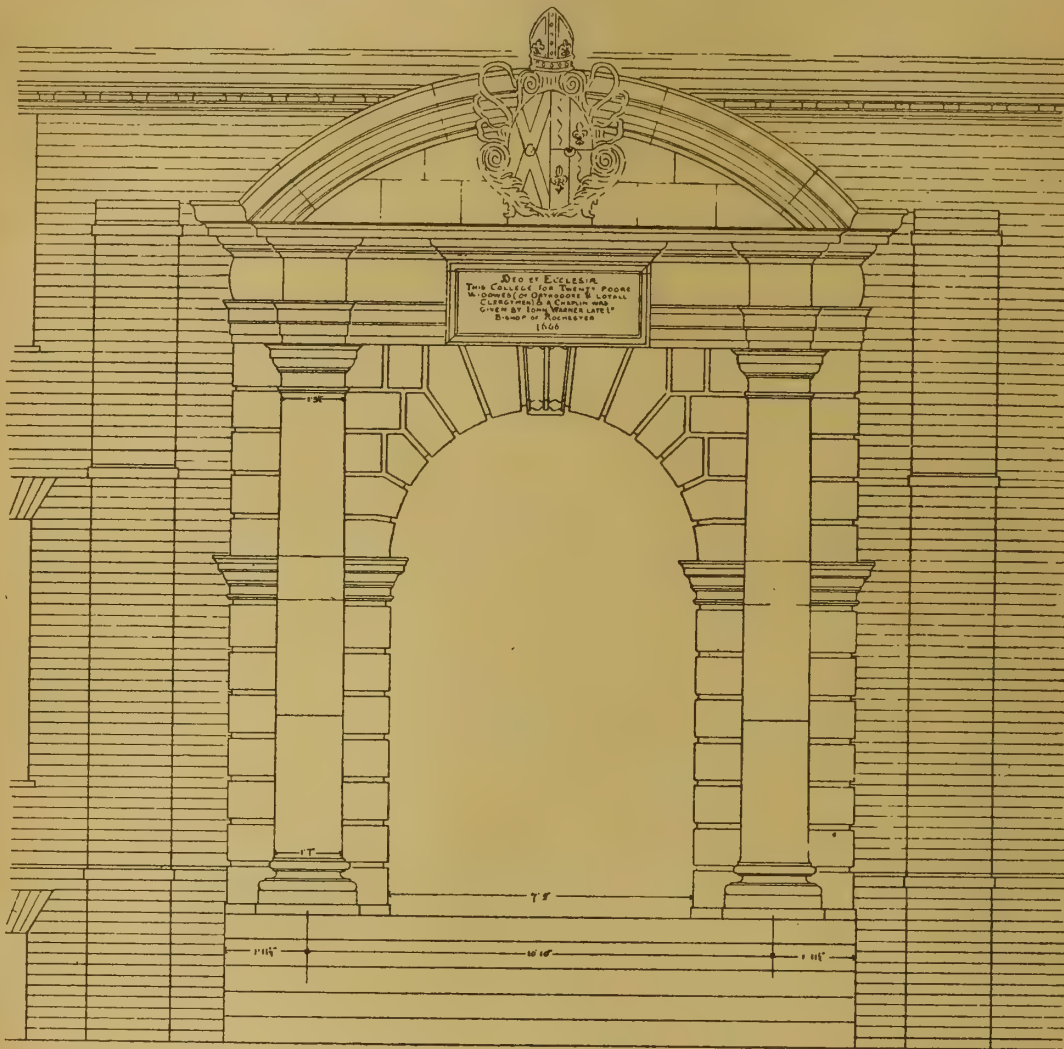
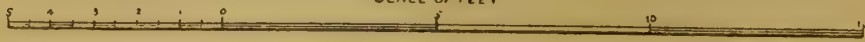

DEO ET ECCLESIAE  
THIS COLLEGE FOR THOMAS POORE  
WIDOWES OF OXFORDS & LUTHER  
CLERKES & A CHAPLAIN WAS  
GIVEN BY JOHN BAKER LATE  
BISHOP OF ROCHESTER  
1666

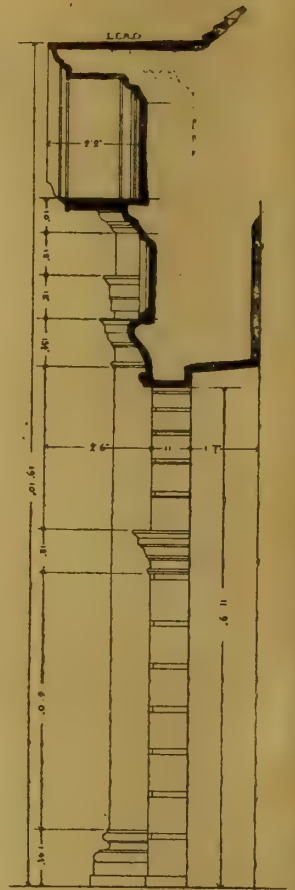

SECTION THRO ARCHWAY

PORTLAND-STONE ARCHWAY IN CENTRE

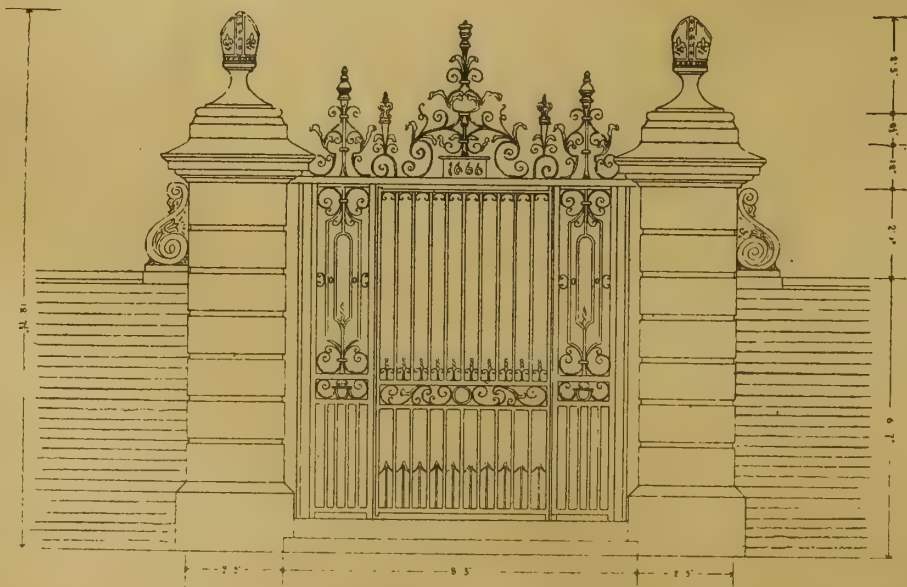

MEASURED  
AND DRAWN BY  
R. ERNEST HILLARIBA

ENTRANCE FROM STREET







# THE HOUSE BY HENRY HAWWICK, F.R.S.

James F. Alison Archt.

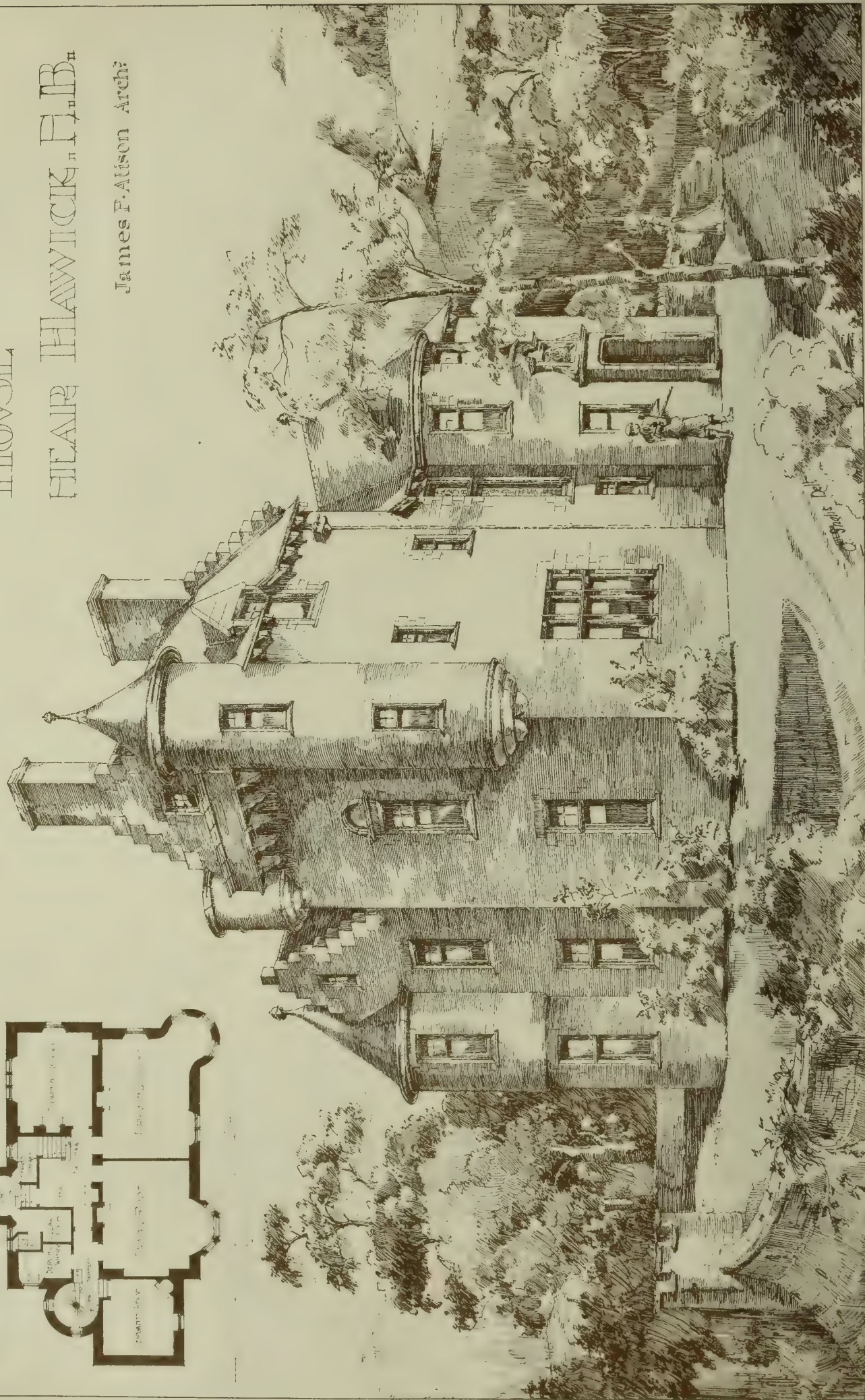

Fig. 1. — The "Pembroke" Residence, James F. Alison, Esq., Queen's Square, W.

THE BUILDING DEWES, JAN. 28, 1898.

BUCKINGHAM PALACE MANSIONS.

WESTMINSTER.

Charles J. C. Pawley Archt.

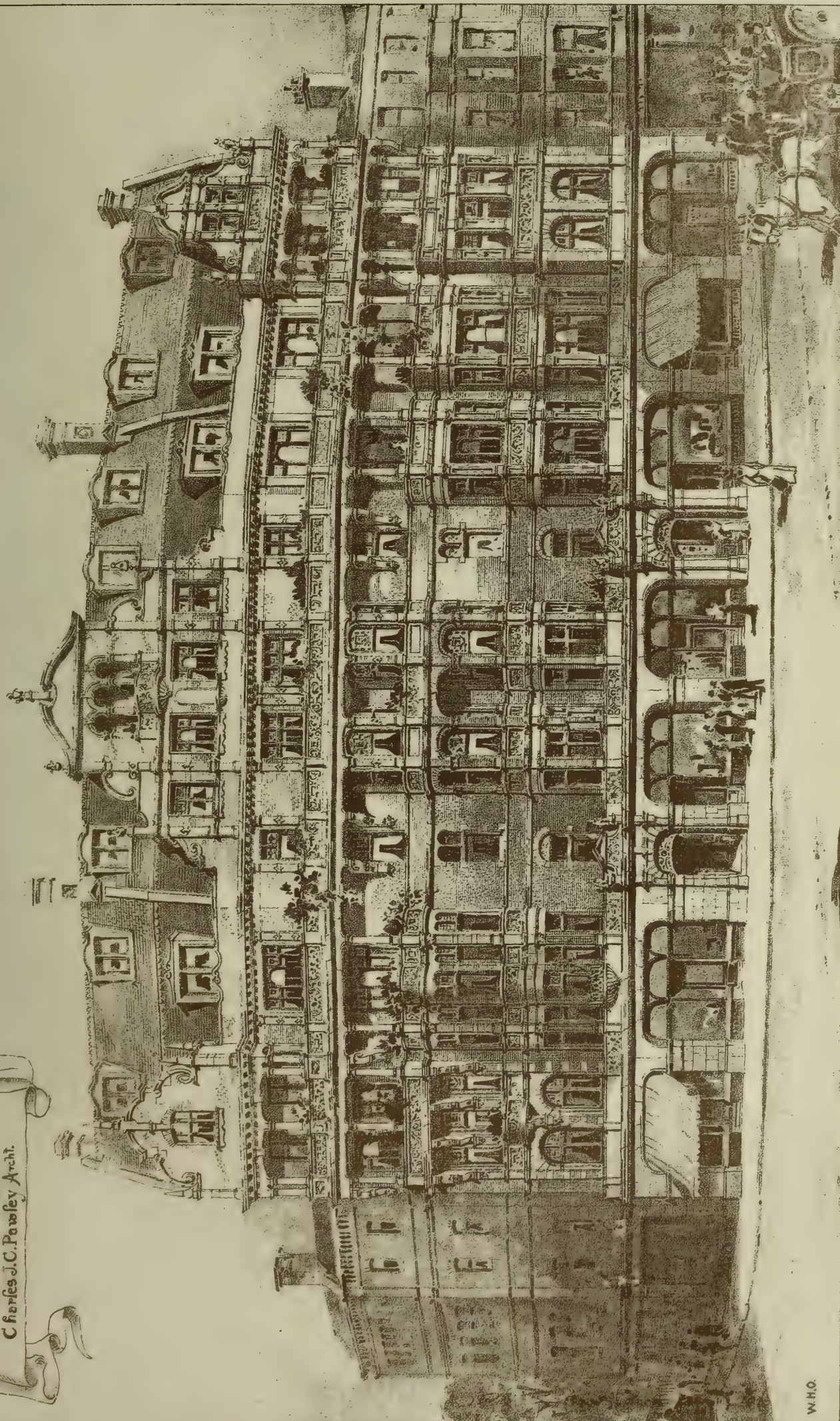

W.H.O.

"Photo-Typr" by James Akerman, 6 Queen Square London, W.C.



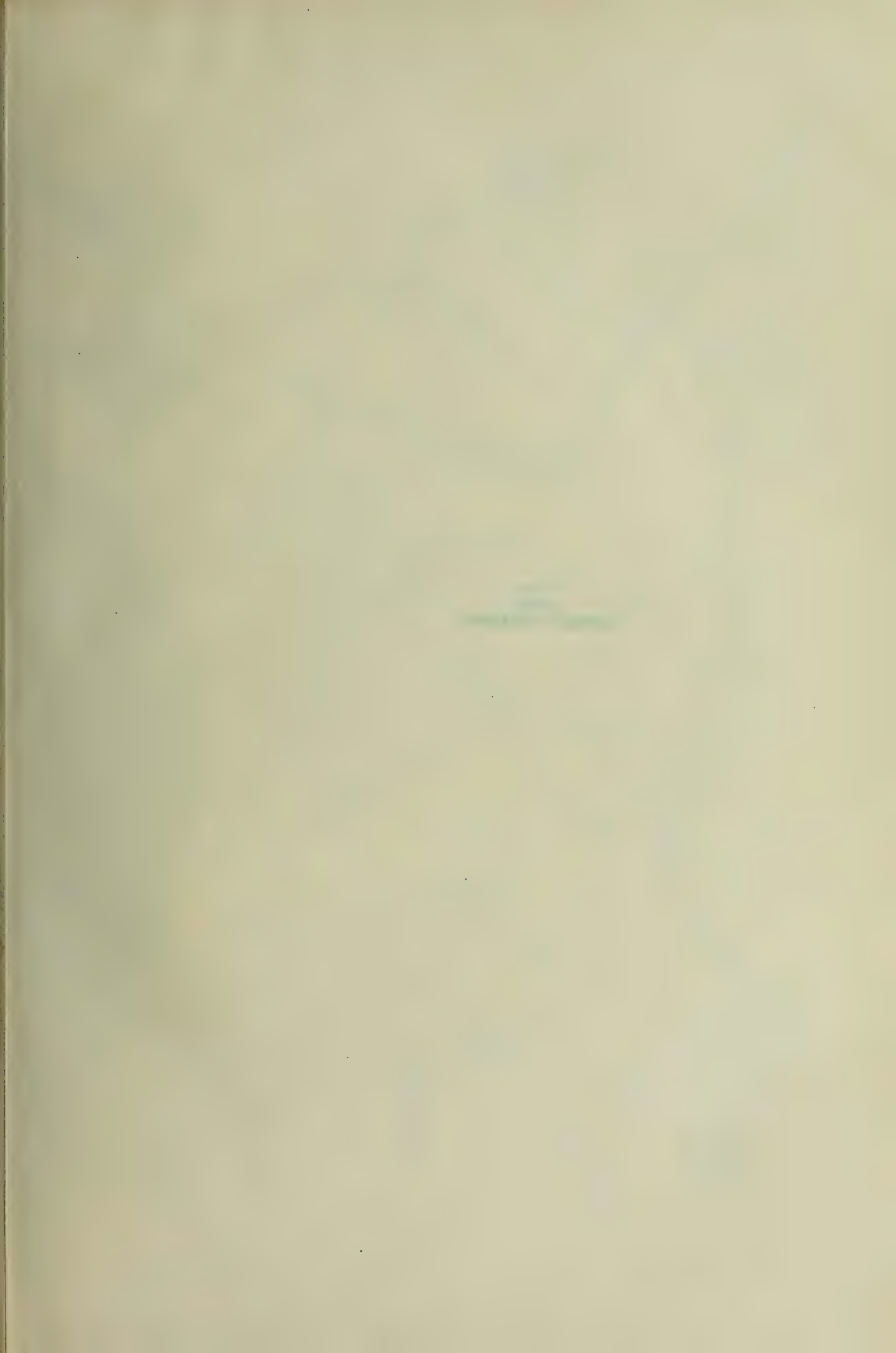

STUDIES OF ANIMAL LIFE TREATED FOR DESIGN

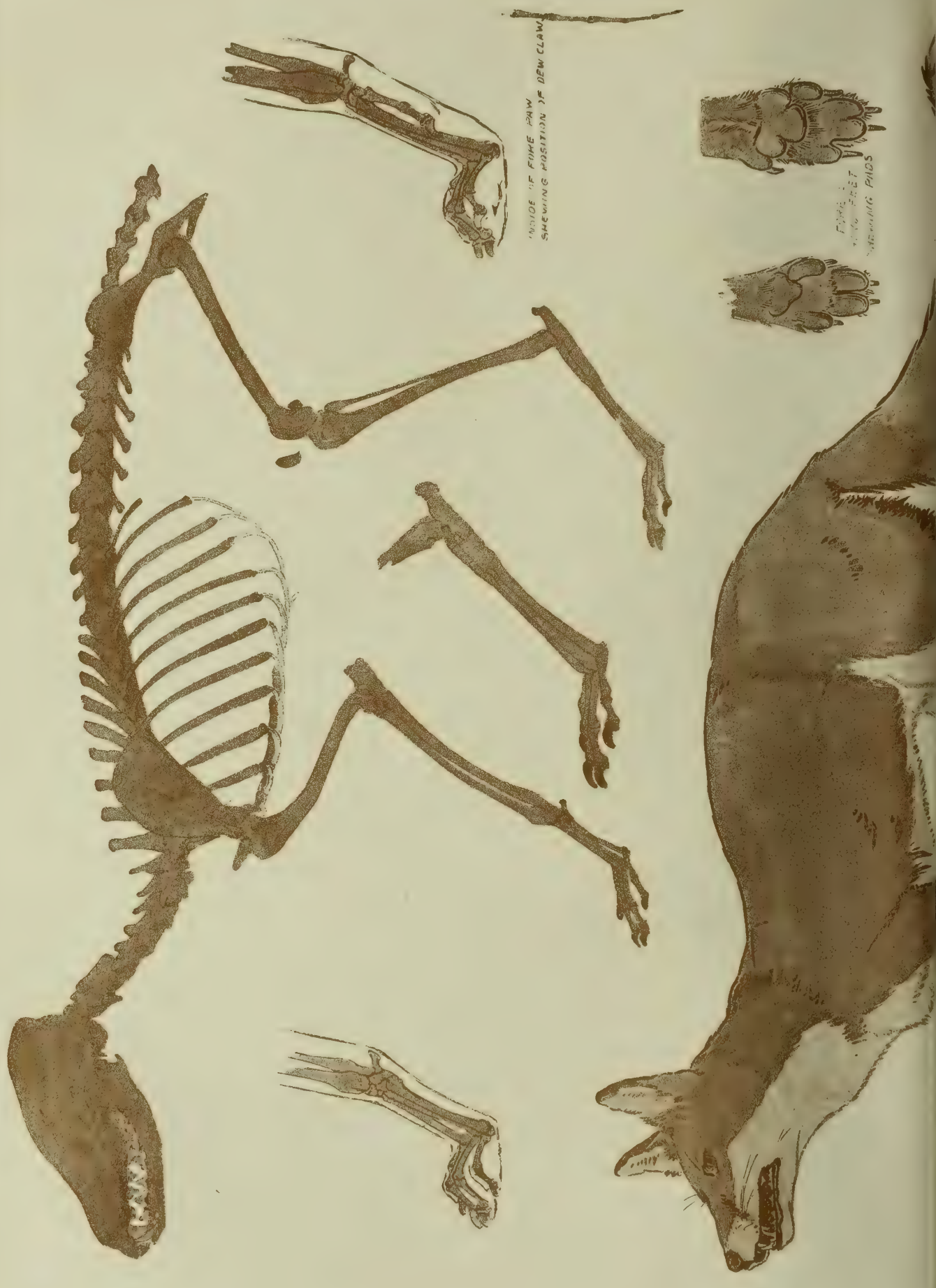



DIAGRAM  
TO SHOW THE  
DIRECTION OF  
THE HAIR

"PHOTO-TINT" by James Abernethy, Queen Square, London, W.C.

NATIONAL SILVER MEDAL AWARDED GEORGE MARPLES

STUDIES FOR ILLUSTRATING THE FABLE OF "THE FOX AND THE CROW"







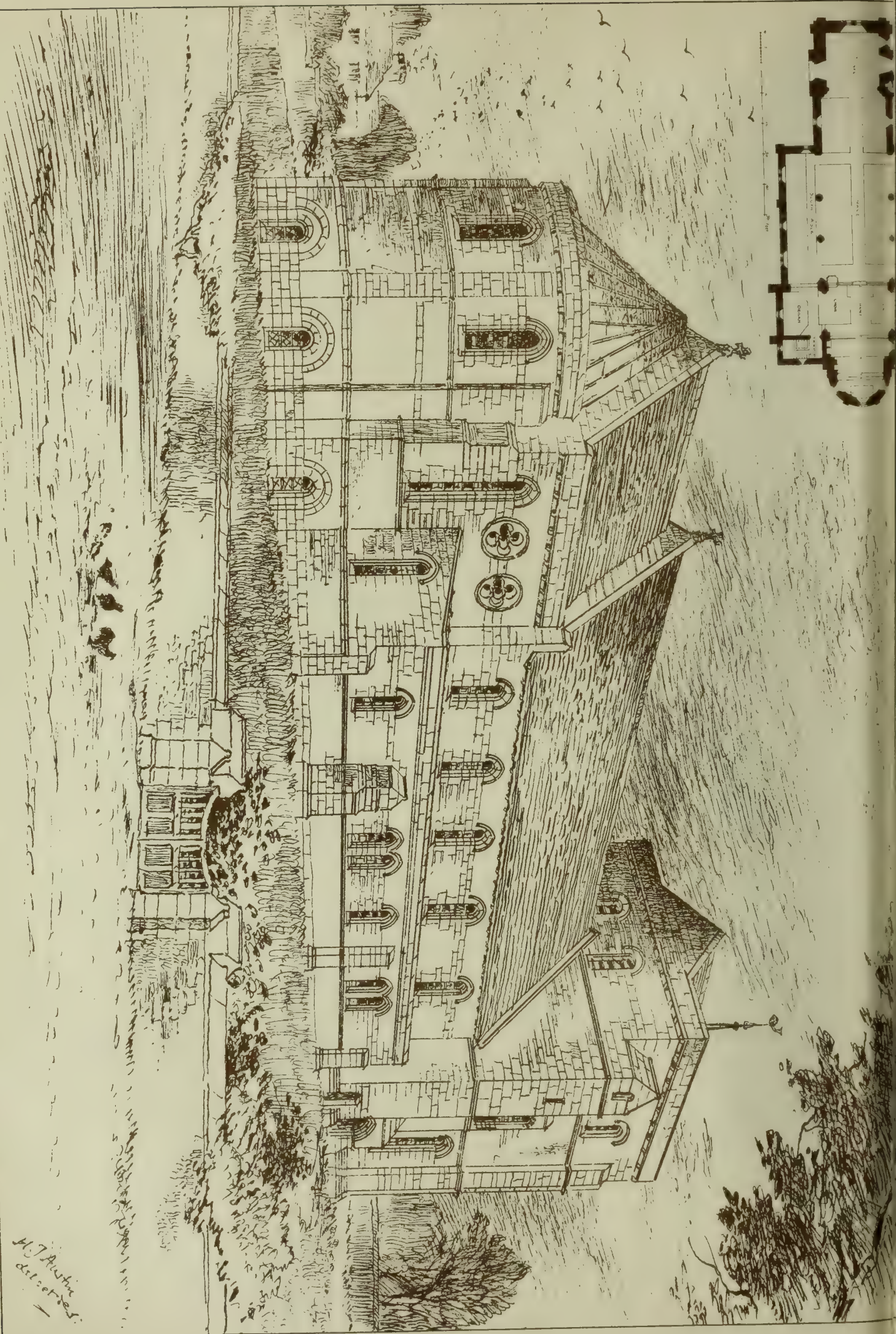
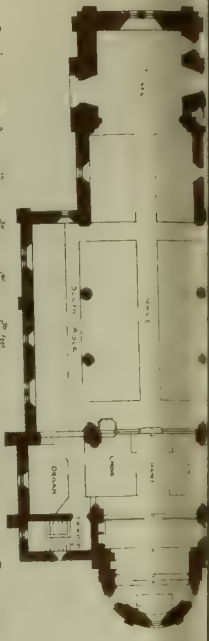

Photo Lithographed & Printed by James Aiseman, 6 Queen Square, W.C.

New Church Tloockburgh.

W. J. Austin & F. J. Riley - Architects

W. J. Austin  
del. & sculp.

THE BUILDING PEWS, JAN. 28, 1898.

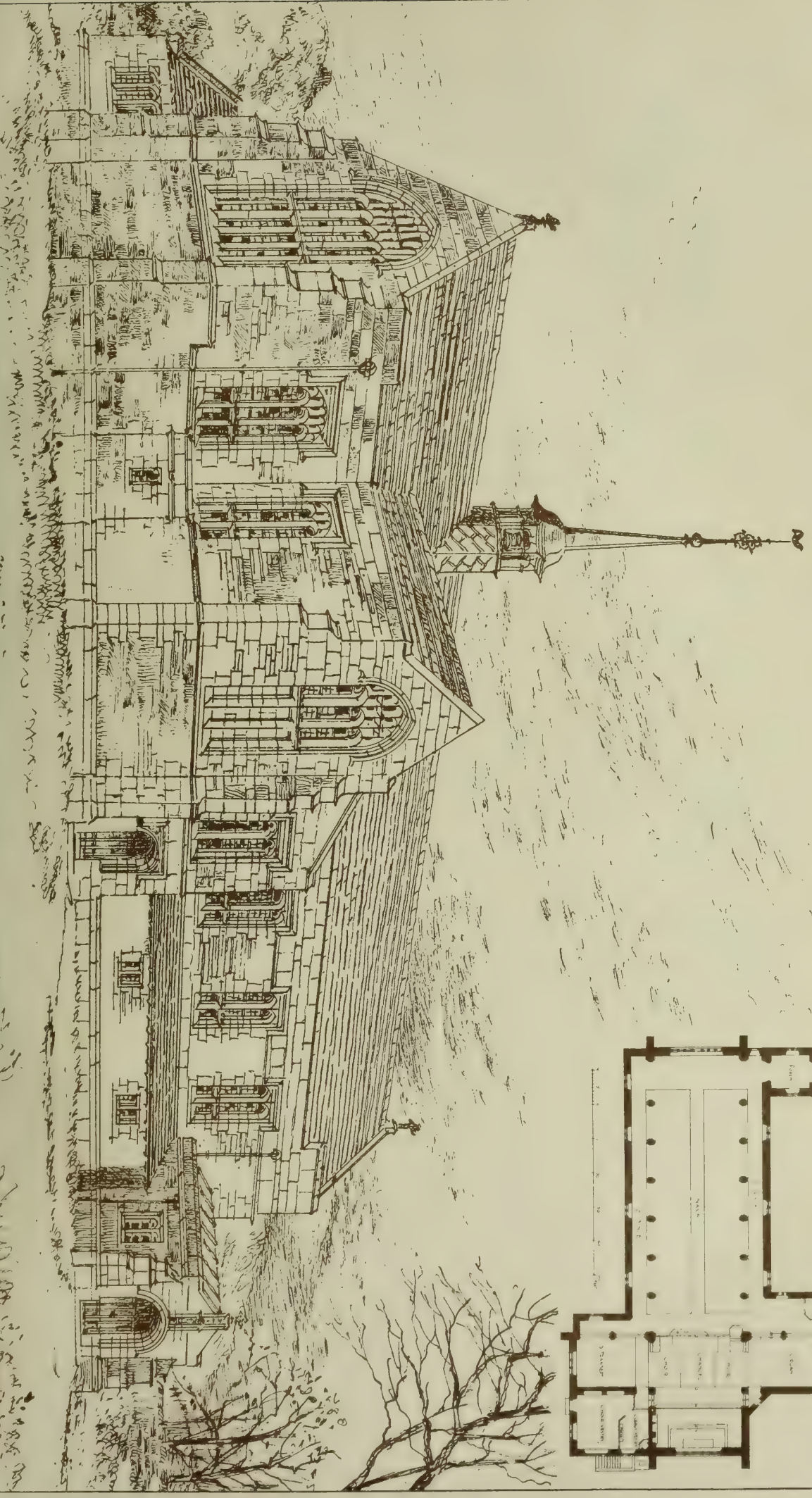
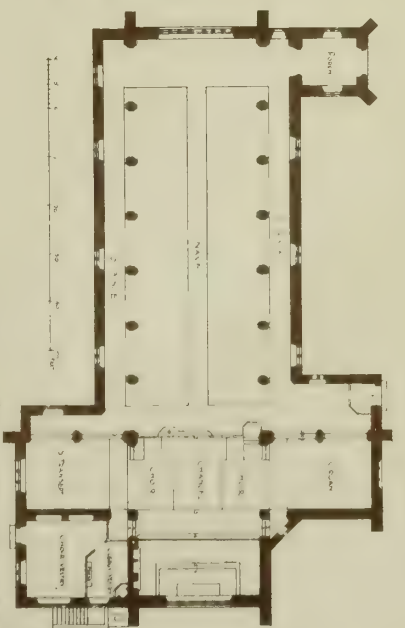

CHAPEL SEDBERGH SCHOOL.





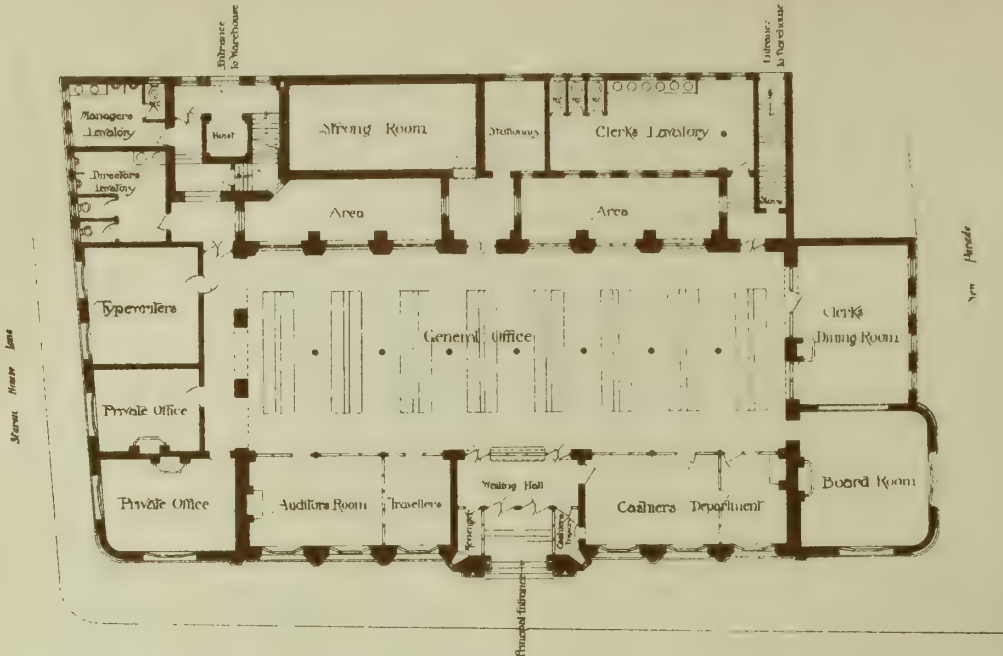

Gelder & Kitchen  
Architects, Lowgate  
HULL.

JAN. 28, 1898.

NEW OFFICES FOR MESS<sup>RS</sup> RECKITT & SONS LD HULL MESS<sup>RS</sup> GELDER & KITCHEN ARCH<sup>T</sup>S



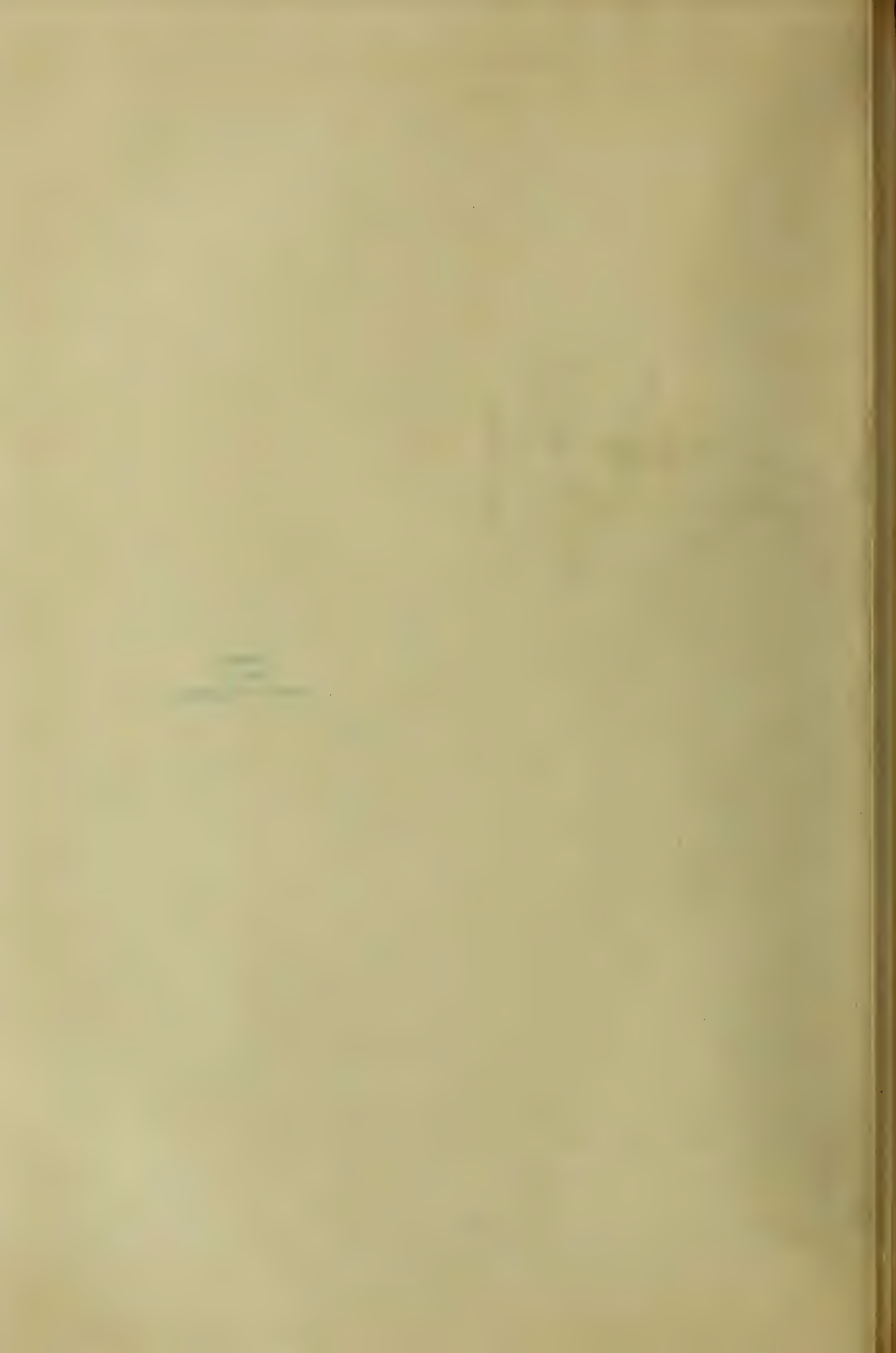



# THE BUILDING NEWS, JAN. 28, 1898.

PRINCIPAL FRONT: 1666.

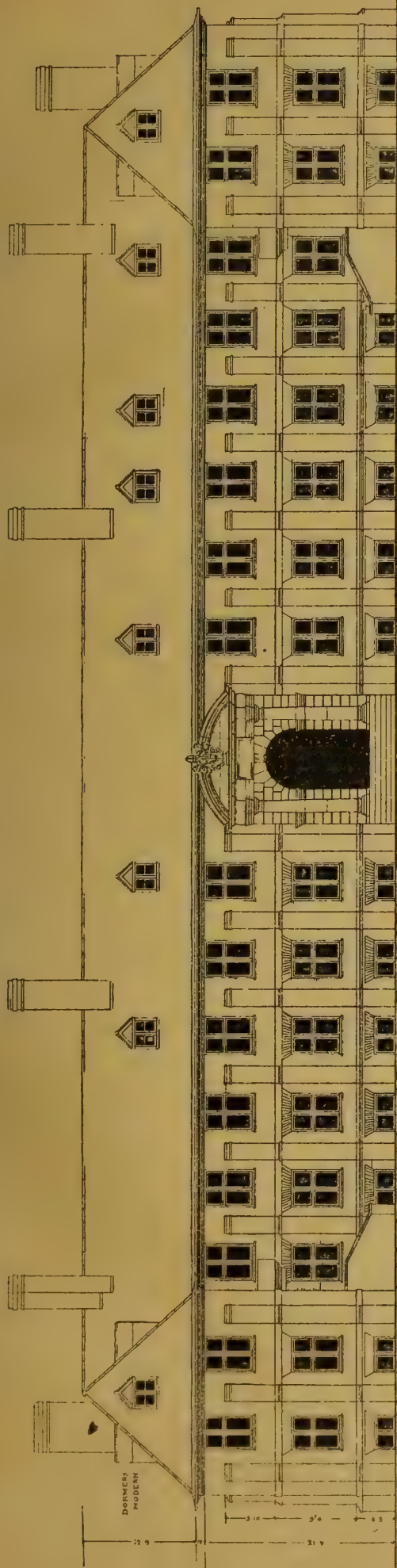

DORMERS MODERN

## BROMLEY COLLEGE KENT

PRINCIPAL FRONT 1666

DRAWN BY RHEGNEST MILL ARIBA



SKETCH PLAN

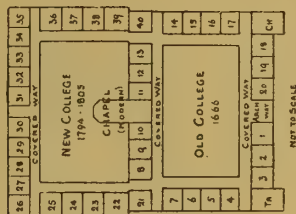

THIS CHARITY WAS FOUNDED BY JOHN WARNER Bp OF ROCHESTER IN AD 1666 FOR TWENTY POOR WIDOWS OF CLERGYMEN. THE ORIGINAL BUILDINGS ARE OF RED BRICKS SAID TO HAVE BEEN BROUGHT FROM LONDON AFTER THE GREAT FIRE, AND THE ARCADEY IN CENTRE IS OF PORTLAND STONE. A SECOND QUADRANGLE WAS ADDED IN 1794-1805 PROVIDING ROOMS FOR TWENTY MORE WIDOWS. THE WOODEN EAVES-CORNICE IS CARRIED ROUND THE WHOLE BUILDING, BUT THE DENTILS EXTEND ONLY 40 FT ALONG THE SIDE ELEVATIONS, AND ONLY THE OLD PORTION HAS BUTTRESSES WITH THE EXCEPTION OF THE PRINCIPAL FRONT. THE BUILDINGS ARE QUITE PLAIN ROOFS ALL TILED, WITH NARROW LEAD FLASHING AT EAVES

SCALE OF FEET

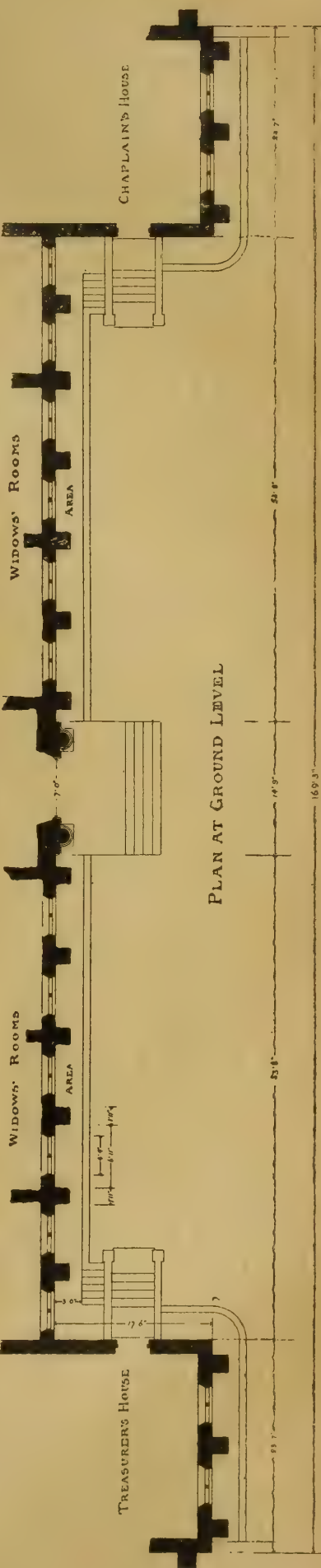

PLAN AT GROUND LEVEL

160 3'

## ARCHITECTURAL & ARCHÆOLOGICAL SOCIETIES.

**THE ARCHITECTURAL ASSOCIATION OF IRELAND.**  
—A meeting of this association was held in the Grosvenor Hotel on the 18th inst, Mr. J. Howard Pentland, R.H.A., F.R.I.B.A., in the chair. Mr. Anthony Scott, M.S.A., delivered a lecture on Mellifont Abbey. The lecturer dealt most exhaustively with the subject of this Cistercian foundation. He illustrated his remarks with numerous sketches and measured drawings by Mr. Scott, jun. Mr. Scott entered on a comparison and analysis of the plans of Mellifont and contemporary Cistercian Abbeys of France. Mellifont boasts a remarkable feature in the shape of an octagonal detached building, generally supposed to be a lavabo or a baptistery. The lecture was also illustrated by a large number of lantern views from photographs taken by the members on the annual excursion.

**THE EDINBURGH ARCHITECTURAL ASSOCIATION.**  
—The members of this association visited Glasgow Cathedral on Saturday afternoon on the invitation of Mr. T. L. Watson, architect, Glasgow, who had asked the members to join others interested in the visit, which was made with a view of examining the lower church by the aid of artificial light. On arrival the party proceeded to the sacristy, where Mr. Thomas Ross, president of the association, took the chair. Mr. Watson read a paper, illustrated by sheets of mouldings and plans, expressing in full manner his views on the date and design of the vaulting of the lower church. In introducing his subject Mr. Watson said he was surprised to read in the preface to the third volume of Messrs. MacGibbon and Ross' valuable work on "The Ecclesiastical Architecture of Scotland" as follows:—"Reference is made in Vol. II. to Mr. T. L. Watson's theory regarding the vaulting of the lower church in St. Mungo's Cathedral, Glasgow. Having recently had the privilege, on the invitation of Mr. P. Macgregor Chalmers, of attending a meeting on the spot, when the usually obscure edifice was well lit up, and when it was shown by Mr. Chalmers that the points on which Mr. Watson based his opinion were untenable, we see no reason to believe that the beautiful design of the vaulting and the plan of the shrine were ever intended to be carried out in a mode different from that in which they are executed." Mr. Watson pointed out that the vaulting of the choir and lower church was of five distinct dates, and these were marked by five different sections of vaulting ribs. As the vaulting ribs of the middle compartment of the lower church were of a later section than those used in the choir vaulting, Mr. Watson urged that the design of the middle compartment vaulting must have been altered, and proceeded to bring forward further detailed proof in support of his contention. The exposition of Mr. Watson's views was followed with much interest, and at the conclusion the party descended to the lower church, which was well lighted by lamps. Mr. P. Macgregor Chalmers, who holds the vaulting to be generally all of one date, vigorously supported his opinion that the original design had been carried out. An animated discussion followed, which was taken part in by Messrs. Ross, MacGibbon, Keppie, John Watson, and Professor Baldwin Brown. At the conclusion of the examination Mr. MacGibbon said he saw no reason to alter the views expressed in the preface already quoted. Mr. Ross moved a vote of thanks to Mr. Watson for the trouble he had taken in this matter, and this was seconded by Mr. Chalmers.

**NOTTINGHAM MASTER BUILDERS' ASSOCIATION.**  
—The seventh annual meeting of the above association was held on Tuesday week at the chambers of the association, Bentinck-buildings, Wheeler-gate, when Mr. James Wright, the vice-president, presided. Mr. Frank Hodson, honorary secretary, and Mr. J. W. Woodsend, the treasurer, respectively presented their reports of the past year's work and finances, both of which showed that the association was in a progressive and solvent state. The hon. secretary, while congratulating the members on the continued activity in the building trade, regretted the restless state of the labour market, and stated that notices had been received of further demands from the masons and labourers for an increased wage and shorter hours. The following gentlemen were unanimously elected as officers for the ensuing year:—Mr. James Wright, president; Mr. William Edgar, vice-president; Mr. J. W. Woodsend, treasurer; Mr. Frank Hodson, hon. secretary.

**ST. PAUL'S ECCLESIOLOGICAL SOCIETY.**—The nineteenth annual report of this society, to be submitted at the meeting of members to be held in St. Paul's Chapter House, E.C., to-morrow (Saturday) afternoon, states that during the past twelve months eight meetings have been held at the Chapter House, and papers have been read by Mr. J. T. Micklethwaite, Mr. W. H. St. John Hope, Mr. J. Ninian Comper, the Rev. Canon Benham, Dr. J. Wickham Legg, the Rev. T. Olden, Mr. Cuthbert Atchley, the Rev. Fr. Robinson, and the Rev. Duncan MacGregor. An exhibition of objects of ecclesiastical interest occupied one evening. Afternoon visits were made to the Charterhouse; to the churches of St. Stephen, Walbrook; St. Swithin, London Stone; St. Mary, Abchurch, and St. Saviour's, Southwark; to Hampton Court Palace, and to Pulborough Church, Sussex, and the neighbouring Hardham Priory. During the past year the society has had occasion to deplore the loss by death of several vice-presidents, including Dr. Walsham How, late Bishop of Wakefield, and Dr. Sparrow Simpson, who in the early days of the society took an active part in forwarding its interests. The council offer their congratulations to the newly-appointed Bishop of Bristol, and tender him their thanks for the services which he has rendered to the society during his residence at St. Paul's. The balance-sheet is of a satisfactory character.

## CHIPS.

The first annual snapper of the recently formed Master Builders' Association of Peteshead was held in the Palace Hotel on Thursday evening in last week. Mr. William Stuart presided, and Mr. John Ferguson, plumber, acted as croupier. Ex-Bailie Fraser, architect, and Mr. Geils, burgh surveyor, were present as guests of the association.

The Duke and Duchess of Fife will perform the ceremony of reopening the Hackney Town-hall on February 9. The building has recently been enlarged by the addition of two wings.

The new Liberal Unionist Club in Edleston-road, Crewe, was formally opened on Saturday last by Lord Arthur Grosvenor. The club is erected on the site of the old building, the foundations of which gave way in the autumn of 1896. Some structural alterations were in progress at that time, when, without any warning, about 5.30 in the morning, the whole building collapsed. It has now been rebuilt from plans by Mr. Joseph Cawley, of Northwich, the contractors being Messrs. Ryland and Sons, of the same town.

An inquiry was held at the Audit House, Southampton, on Tuesday in last week by Col. H. C. Luard, relative to an application by the Southampton Corporation for powers to borrow the sum of £1,080 for the purpose of erecting public conveniences in the High-street and Chantry-road. The borough engineer, Mr. W. D. G. Bennett, and Mr. Killick, assistant engineer, explained the plans and specifications.

A public inquiry was held at the town-hall, Warminster, on Friday, into the application made by the urban district council to the Local Government Board for sanction to the borrowing of a loan of £5,000 for sewage works and sewage disposal on the septic tank system for the town. Colonel Coke conducted the inquiry. Mr. A. F. Long, surveyor to the council, produced the plans and estimates, which were supported by Mr. Martin, one of the patentees of the septic tank system. Evidence in opposition to the scheme was given by Mr. A. P. I. Cotterell, A.M.I.C.E., of Bristol.

The urban district council of Sevenoaks have received from Col. Bevington a valuable collection of prehistoric implements found in the district during the past seven-and-twenty years.

Mr. A. E. Sandford Fawcett, C.E., F.G.S., of 1, Victoria-street, S.W., has been appointed a temporary engineer inspector at the Local Government Board, and Messrs. John Taylor, Sons, and Santo Crimp, of 27, Great George-street, S.W., have taken over the practice.

Work has been commenced this week on the new sea wall and beach gardens at Great Yarmouth.

The markets committee of the Newcastle Corporation have recommended the town council to spend £7,000 for the purpose of building a new roof in the wide alley of the market, and to renovate the present stalls in the book and poultry department.

At the town hall, Burnham, Somerset, on the 20th inst. Colonel Slacke, R.E., held an inquiry into a proposal by the urban district council to borrow £7,000 for the erection of a new sea wall, the provision of shelters, and erection of public conveniences at Burnham. Mr. W. J. Press, surveyor to the urban authority, explained the plans.

A Wesleyan church has been erected at Acrefair—a mining village midway between Llangollen and Ruabon—at a cost of £1,000, and the opening ceremony took place on Saturday. Mr. J. W. Jones, Brooklea, Acrefair, was the architect.

The Bill for powers to construct, at a cost of £1,225,734, an electric underground railway, connecting Charing Cross, *via* Knightsbridge, with Paddington terminus, has been officially marked dead at the Houses of Parliament.

Mr. A. Harry Heron, A.R.I.B.A., of 27, Fitzroy-street, Fitzroy-square, London, W., has taken Mr. Clifford Bellairs into partnership as from Jan. 1, 1898, and the style of the firm will be Heron and Bellairs.

A new hall in connection with the Presbyterian Church of England, Armstrong-road, New Benwell, was opened for public worship on the 20th inst. It is seated for 450 persons, and has been built from plans by Messrs. Badenoch and Bruce, of Newcastle-on-Tyne.

The city engineership of Liverpool, the salary for which will commence at £1,000 per annum, is being eagerly sought for by engineers of the country, says the *Liverpool Mercury*, as is evidenced by the fact that between 50 and 60 applications have been received for the post, which has been rendered vacant by the resignation of Mr. H. Percy Boulnois, now an inspector under the Local Government Board. These are to be tabulated, and will shortly be considered by a committee of the corporation.

The Keene Memorial Tablet at Hammersmith Public Library, which we illustrated a fortnight since, was erected by public subscription, Mrs. Edwards, of Golden-square, acting as hon. secretary. Mr. Passmore Edwards gave the twin tablet to the memory of Leigh Hunt.

The Maidstone Town Council resolved, at their meeting on Wednesday, to apply for an Act of Parliament for the purchase of the Waterworks. Counsel's opinion was read to the effect that the corporation had no right of action against the water company, but that persons whose illness was directly caused by polluted water had that right. Several fresh cases of typhoid have been notified in the past fortnight, this increasing the aggregate to 1,910.

The town council of Haddington resolved on Tuesday to instruct Messrs. Carfrae and Belfrage, engineers, of Edinburgh, to prepare plans and advise them on the construction of a new bridge across the Tyne between Haddington and Nungate.

The Islington Vestry have decided to spend £8,500 in laying out the land at the Islington Cattle Market, recently purchased from the Corporation of the City of London for the purpose of a public park.

Mr. William Fletcher, brick manufacturer, Carlton-villa, Lostock, was driving home on Friday night, and upon getting off his trap the reins became entangled about his legs, and he ran forward. The horse backed in an opposite direction, and Mr. Fletcher was thrown to the ground. He was picked up in an unconscious condition, and expired at midnight. He was 47 years of age, married, and leaves a family.

The annual meeting of the Aberdeen Master Plasterers' Association was held in the office of the secretary, Mr. Thomas A. Coats. The chair was occupied by Mr. Alexander Baxter, president of the association. The following appointments for the current year were made—viz., president, Mr. A. Baxter; vice-president, Mr. David Scott; secretary and treasurer, Mr. Thomas A. Coats, S.S.C.; finance committee, Messrs. A. Baxter, David Scott, and David Stephen.

The temporary church of St. Margaret is now in course of erection on a site adjoining Cardigan Villas, on the east side of Cardigan-road, Leeds. The building is 70ft. long by 32ft., and will accommodate about 300 people. Clergy and choir vestries are provided. Messrs. Smith and Tweedale, of Leeds, are the architects.

The Main Drainage Committee of the London County Council report that during the year ended December 31 last 46,494 and 33,373 million gallons of crude sewage were treated at the Barking and Crossness outfall works respectively, together making a total quantity of 79,867 million gallons, or an average of nearly 219 million gallons per day. During the same period 1,408,000 and 697,000 tons of sludge were sent to sea from the respective stations.

At the special memorial service for the late Prince Henry of Battenberg, held on Thursday in last week at Whippingham Church, the Florentine screen, designed by Mr. Alfred Gilbert, R.A., M.C.V.O., was unveiled. It is of wrought iron, and is placed between the chancel and memorial chapel. It is decorated with four Royal shields, bearing the arms of the Queen, the Prince Consort, Prince Henry of Battenberg, and Princess Henry of Battenberg; the shields are in silver, and the metals and tinctures are in enamel.

**TO CORRESPONDENTS.**

[We do not hold ourselves responsible for the opinions of our correspondents. All communications should be drawn up as briefly as possible, as there are many claimants upon the space allotted to correspondents.]

It is particularly requested that all drawings and all communications respecting illustrations or literary matter should be addressed to the EDITOR of the BUILDING NEWS, 392, Strand, W.C., and not to members of the staff by name. Delay is not infrequently otherwise caused. All drawings and other communications are sent at contributors' risks, and the Editor will not undertake to pay for, or be liable for, unsought contributions.

Cheques and Post-office Orders to be made payable to THE STRAND NEWSPAPER COMPANY, LIMITED.

**TERMS OF SUBSCRIPTION.**

One Pound per annum (post free) to any part of the United Kingdom; for Canada, Nova Scotia, and the United States, £1 6s. 0d. (or 6dols. 30c. gold). To France or Belgium, £1 6s. 0d. (or 3fr. 30c.). To India, £1 6s. 0d. To any of the Australian Colonies or New Zealand, to the Cape, the West Indies, or Natal, £1 6s. 0d.

**ADVERTISEMENT CHARGES.**

The charge for Competition and Contract Advertisements, Public Companies, and all official advertisements is 1s. per line of Eight words, the first line counting as two, the minimum charge being 6s. for four lines.

The charge for Auctions, Land Sales, and Miscellaneous and Trade Advertisements (except Situation advertisements) is 6d. per line of Eight words (the first line counting as two), the minimum charge being 4s. 6d. for 40 words. Special terms for series of more than six insertions can be ascertained on application to the Publisher.

Front-page Advertisements 2s. per line, and Paragraph Advertisements 1s. per line. No Front-page or Paragraph Advertisement inserted for less than 5s.

Advertisements for the current week must reach the office not later than 3 p.m. on Thursday. Front-page Advertisements and alterations in serial advertisements must reach the office by Tuesday morning to secure insertion.

**SITUATIONS.**

The charge for advertisements for "Situations Vacant" or "Situations Wanted" is ONE SHILLING FOR TWENTY-FOUR WORDS, and Sixpence for every eight words after. All Situation Advertisements must be prepaid.

**NOTICE.**

Bound copies of Vol. LXXII. are now ready, and should be ordered early (price Twelve Shillings each), as only a limited number are done up. A few bound volumes of Vols. XXXIX., XL., XLI., XLII., XLIII., XLIV., XLV., XLVI., XLVII., XLVIII., XLIX., L., LI., LII., LIII., LIV., LV., LVI., LVII., LVIII., LIX., LX., LXI., LXII., LXIII., LXIV., LXV., LXVI., LXVII., LXVIII., LXIX., LXX., LXXI., LXXII. may still be had, price Twelve Shillings; all the other bound volumes are out of print. Most of the back numbers of former volumes are, however, to be had singly. Subscribers requiring any back numbers to complete volume just ended should order at once, as many of them soon run out of print.

ROLLERS FOR GRANOLITHIC WORK.—A subscriber wants the address of makers of above. Says he has seen an advt. of such in our pages some time, but fails to find it. If makers write to us, we will send him on name and address. We may point out that there is scarcely a week in which we are not thus asked for addresses, and wonder very much that more do not avail themselves of our "Directory," which was intended to give the help thus sought.

RECEIVED.—M. G. R.—H. T. T.—F. H.—O. G. and Co.—L. T.—W. T. F.—N. G. (Salford).

**Correspondence.**

**SINGAPORE TOWN HALL COMPETITION—A DISCLAIMER.**

To the Editor of the BUILDING NEWS.

SIR,—My attention has been called to a notice under "Prize Competitions" in your issue of 21st inst., giving my name in connection with a Singapore town hall competition.

I write to say that I am not in any way connected with this competition, and cannot undertake to answer inquiries, and I shall be much obliged if you will give every publicity to this fact in your next number.

The notice in your paper should not be repeated, as it has been inserted without my knowledge or consent—in fact, early in November I declined to associate myself with this concern owing to the, in my opinion, incomplete and unsatisfactory nature of the competition arrangements made by the local committee.—I am, &c.,

M. A. CAMERON.

Downing-street, S.W., Jan. 26.

**THE INTERNATIONAL BUILDING TRADES EXHIBITION.**

SIR,—I am constantly receiving inquiries as to the Building Trades Exhibition, which your readers presumably think is to be held in March of this year.

Will you kindly allow me to state that this exhibition will not be revived until March, 1892?—I am, &c., H. GREVILLE MONTGOMERY, 43, Essex-street, Strand, W.C., Jan. 24.

**A CORRECTION.**

SIR,—I have only just noticed that in your report (in last week's issue) of the case of "Brooks' Trustees v. the St. Pancras Guardians," I am described as a partner in this firm. This is not so, nor, in my evidence, did I so describe myself; I am a manager and buyer—not partner.—I am, &c., W. J. RENSHAW, Warren-lane Works, Woolwich, Jan. 22.

**CHIPS.**

The president of the Local Government Board has appointed Major-General C. P. Carey, R.E., Chief Engineering Inspector, in the place of Major Tulloch, C.B., R.E., who has retired. Colonel J. O. Hasted, R.E., has been appointed Deputy Chief Engineering Inspector.

The sixth annual dinner of the Shrewsbury and District Master Builders' Association was held on Wednesday evening in last week at the Lion Hotel, Shrewsbury. Mr. H. Farmer, the president for the year, occupied the chair, and Mr. W. T. Williams, the vice-president, was in the vice-chair.

The Birmingham Board of Guardians adopted at their last meeting plans for an additional building to accommodate female epileptics at an estimated cost of £4,485, and for adopting the cell system in the tramp wards at a further estimated cost of £2,235.

Business was again very quiet last week at the London Auction Mart, the returns falling below those of the corresponding week not only in last year, but also in 1896. This was due to the small supply of properties, for otherwise there was a tendency towards improvement in the demand for houses and land generally. The principal transaction of the week was in regard to a freehold public-house on the main Haverstock-hill, which realised £4,800. Altogether the returns amounted to £16,000, which falls short of the corresponding week in last year by £1,450.

The Bramley parish church organ, which has been entirely rebuilt by Mr. J. J. Binns, of Bramley, was reopened on Friday. Additional bellows have been added, also a new hydraulic engine, and a new system of heating apparatus. The pipes have all been revoiced, and new stops added. A new oak screen (to the west arch) has been presented by Mr. Binns as a Jubilee memorial.

The Primitive Methodist chapel in West-street, Boston, Lincolnshire, which was destroyed by fire on January 28 in last year, having been thoroughly rebuilt and restored, has been reopened for public service. The contract for the exterior work and for the painting and plastering was entrusted to Mr. W. Greenfield, and for the woodwork in the interior to Mr. C. Jessop. Mr. T. Howdill, of Leeds, was the architect. A new organ has also been supplied at a cost of £250 by Messrs. Hewitt, of Leicester. The chapel provides seating accommodation for 800 persons.

New British schools at Truro were opened last week. They occupy a site on Chapel Hill, and accommodate 450 children. Mr. Silvanus Trevail, of Truro, was the architect, and Messrs. Clemens and Battershill took the contract at £1,632, exclusive of fittings and fences.

Messrs. Hill and Co., contractors, of Gosport and Portsmouth, have this week taken over from the Admiralty the work of completing the construction of a new breakwater, extending from Binclaves, at Weymouth, to the existing one at Portland, thus forming a complete basin for ironclads to anchor within. The work will extend over a period of 4½ years, and the contract price is something like half a million of money. There are two entrances to the new breakwater.

Sixty applications were received for the post of assistant chief engineer to the Bristol Docks Committee. Mr. Thomas Arthur Pearce, whom the committee have decided to recommend to the council for appointment, is 33 years of age. His first training was as a mechanical engineer to the firm of Messrs. W. Collier and Co., formerly carrying on business at Salford. He was afterwards engaged on the Manchester Ship Canal works.

At Southampton, on Monday evening in last week, the members of the firm of Messrs. F. and J. Young, builders and contractors, on the occasion of the completion of the new offices and building works, Upper Clovelly-road, invited several friends and the whole of their employes to a dinner. A large company assembled in the principal workshop, which had been tastefully decorated for the occasion. The chair was taken by Mr. Councillor C. Thomas, J.P., who was supported by Messrs. F. and J. Young.

**Intercommunication.**

**QUESTIONS.**

[1886].—Board of Trade Appointments.—Can any of your correspondents say what are the functions of those private practitioners whom one now and then sees announced as "having been appointed surveyors and arbitrators to the Board of Trade"?—INQUISITIVE READER.

**REPLIES.**

[1884].—"Red" and "Yellow" Deal.—These are different names for the wood of the same description of tree—viz., the Scotch fir or *Pinus sylvestris*. Some classes of people—as timber merchants, and some builders, carpenters, and joiners—call the wood red; others, mostly of the latter class, but in other parts of this country, call it yellow. It varies much in quality, according to age of tree, latitude of country of growth, soil level, and aspect of place of origin, and many other local circumstances. Some of it is coarse, thick-grained, dense, and heavy, and fit for timbering; some is fine, straight-grained, and mild, suitable for joinery. And there is every intermediate variety of quality. The timbering quality may be obtained from Memel, Riga and Dantzic and the Northern ports of Sweden, that from the first three ports being the best. In the balk state it is generally called "fir," but it is from the same botanical tree. The best mild joinery deals are obtained from the White Sea ports—from Petersburg, from Finland, and some of the Swedish ports. As to the use to which any particular quality may be adapted, that is a matter of judgment. Almost all the qualities have their particular defects—as cross grain, sapwood, "heart," "cup," and "star" shakes, "decayed" and "ring-galled" knots. Why not read Stevenson's "Wood and its Constructive Uses" (London: Batsford), as recommended by a correspondent in reply to Mr. D. Forbes Smith's letter? The subject is too large and complicated to be further pursued in these columns.—A. H.

A memorial obelisk has been placed over the grave of Coventry Patmore, the author of "The Angel and the House," in the cemetery at Lyminster.

Colonel A. Smith, of the Local Government Board, held an inquiry at Doncaster, on Friday, as to the corporation borrowing £1,250 for the purchase of land for street improvements, the corporation proposing to sell consols for the amount, and to repay the money by instalments in fifty years. The town clerk explained that the street proposed to be widened was one used as the return route from the course to the station during the races. There was no opposition.

The watching and lighting committee of Glasgow Corporation passed plans, on Friday, for the new fire brigade station, which is to be erected on the site of Newsome's old circus in Ingram-street. The building is estimated to cost £40,000.

In response to an application by the Northwich Rural District Council for sanction to borrow £520 for works of water-supply for the townships of Cuddington, Hartford, and Weaverham, Mr. Robt. H. Bicknell, inspector under the Local Government Board, held an inquiry at the Sandiway Hotel, near Northwich, on Friday.

The ceremony of opening the new swing bridge at Swansea was performed on Thursday in last week by Lady Jenkins, wife of Sir John Jones Jenkins, chairman of the Harbour Trust. The bridge, which crosses the River Tawe to St. Thomas and Prince's Dock, has been constructed at a cost of £30,000. The Harbour Trustees afterwards paid an official visit to the new works in connection with the extension of Prince's Dock, which cost £100,000, and the new works of the extensive dry dock, costing £60,000.

At a Consistory Court held in York Minster on the 20th inst. a faculty was granted to the vicar and churchwardens of Whitgift to take down the chancel and schoolroom beyond, to build a new chancel, to re-floor, re-seat, and re-fit the nave and aisles, to re-fix the present pulpit and font, to form a vestry at the west end, and to make other alterations.

Beech Grove Congregational Church, Newcastle-on-Tyne, was opened by the Rev. Dr. Joseph Parker on Tuesday. It has been built by Mr. G. H. Mauchlen, contractor, from designs by Mr. Stephen Piper, architect, Newcastle, selected in open competition. The foundation-stones were laid on Oct. 14, 1896. The contract price of the building was £8,000, and the church provides accommodation for 750 adults, allowing 20in. to each person. The fittings are of pitch-pine. The lecture-hall, which was erected before the church was begun, is at the north end of the site, and there are also classrooms and caretaker's apartments, &c. The contractors were: masonry, carpentry, joinery, and plastering, Mr. Mauchen; slating, Messrs. Beck and Sons; painting, Mr. John Campbell; plumbing, Mr. John Rowell; heating and hardware, Messrs. Emley and Sons; and electric lighting, Mr. S. Bury, all of Newcastle. The glazing was by the Gateshead Stained Glass Co., and the wood block flooring by Mr. Roger L. Lowe, of Farnworth, near Bolton.

## LEGAL INTELLIGENCE.

**ROYDON BRICK AND TILE CO., LTD.**—A winding-up order having been made against this company on December 8 last, meetings of creditors and contributories were held last week at the Board of Trade Offices, Carey-street, Lincoln's Inn-fields. Mr. Warley, Assistant Official Receiver, presided, and stated that the company was incorporated on May 28, 1896, with a nominal capital of £25,000, and was formed to acquire and carry on a brick and tile manufacturing business at Roydon, Essex, owned by Mr. Thomas Quinn, now deceased. The company acquired the property for £10,250, a lease for fifty years being also granted, the rent being fixed at £200, with a royalty of £500 per annum. No prospectus was issued, and it was stated that one of the objects of the promotion was to raise money on debentures, and altogether £4,000 had been issued. The purchase money was satisfied by the payment of £250 in cash, and £10,000 shares were allotted to Mr. Quinn as fully paid. The failure of the company was ascribed to the want of proper management, which resulted in the manufacture of defective bricks. The heavy cost of cartage also contributed to the failure, the estate (which covered 68 acres) being some distance from a railway station. The unsecured liabilities were estimated at £2,874, and £4,000 was due upon debentures. The assets were estimated to produce £1,107, and, as regards contributories, there was a deficiency of £15,773. The estate was now in the possession of Mr. T. Garman, who was appointed receiver under an administration order of the late Thomas Quinn, but his claim to the property was not acknowledged by the Official Receiver. So far as could be ascertained, there was no prospect of the unsecured creditors receiving anything. The contributories resolved to leave the matter in the hands of the Official Receiver as liquidator, and the meeting of creditors was adjourned *pro forma*.

**IMPORTANT ARBITRATION.**—**JOHN DICKESON, JUN., v. HEPBURN AND GALE, LIMITED.**—In this case, J. Dickeson, jun., builder and contractor, 11, Lintwood-road, Balham, referred to arbitration his claim for £300, balance of a building contract executed for Messrs. Hepburn and Gale, Ltd., leather dressers, of 239, Long-lane, Bermondsey. Mr. Henry Currey, architect, of 37, Norfolk-street, Strand, was the arbitrator. Mr. E. M. Bray, Q.C., appeared for Mr. Dickeson, and Mr. Glen appeared for Messrs. Hepburn and Gale. Mr. Dickeson, jun., entered into a contract to erect an addition to Messrs. Hepburn and Gale's factory within three months from April 11, 1896, failing which he was to incur a penalty of £5 per day for every day beyond that time. The works in question were not completed until Oct. 1, 1896, or 80 days beyond the specified time, for which the employers claimed £400 as liquidated damages; but upon the certificate of their architect, Mr. Joseph Gale, dated Nov. 11, 1897, that the works could not have been reasonably completed before Aug. 22, 1896, they modified their claim accordingly. The contractor repudiated the claim on the grounds that he was delayed by extra works occurring in the excavation of the foundations; also in the supply by other contractors to the employers of the constructional ironwork and iron sashes in connection with the building. Messrs. Hepburn and Gale had entered into contracts with two other firms for the supply of this ironwork, and the contractor's specification provided only that he should build in the ironwork as supplied. It appeared from the correspondence between the various parties in connection with the work, that Messrs. Hepburn and Gale had already obtained payment of fines from these firms for non-delivery within the contract time. Mr. Bray, for the contractor, also contended that the wording of the contract provided that if the work be delayed by any causes not under the contractor's control, due allowance should be made by the architect, and then the contractor should complete the work within such time as the architect should consider reasonable, and should, from time to time, in writing appoint; but no time had been appointed by the architect during the progress of the work for completion, nor had he appointed any date until he gave his certificate of the 11th of November, 1897, nearly fourteen months after the works were finished, when he certified in writing they could reasonably have been completed by the 22nd of August, 1896—i.e., six weeks after the original contract time. He also said that, as no time had been appointed during the progress of the work, the employers had no claim on the contractor for damages. Mr. Glen, for the employers, said this was a legal point on the construction of the contract which could not be decided by the arbitrator without legal advice, or being taken before a Judge of the High Court; but after some argument, counsel agreed that the arbitrator should have a legal adviser to sit with him, to give his opinion. This course was adopted, and Mr. Currey awarded, on the 22nd Jan., 1898, that the sum of £300, balance of the contract, is to be paid forthwith by the employers to Mr. John Dickeson, jun.; also that the employers should

forthwith pay the sum of £37 11s. 6d., being the arbitrator's charges for the reference; and, moreover, the employers were to pay the whole of Mr. John Dickeson, jun.'s costs of the reference to arbitration upon taxation of same. The above case was heard on Dec. 20, 1897, at Room 521, Law Courts, Strand, and adjourned to Dec. 23, 1897, at Mr. Currey's office. He gave his award on Jan. 22 inst. Messrs. Hoggoods and Dawson, solicitors, 17, Whitehall-place, acted for Mr. J. Dickeson, jun. Messrs. Benson and Co., solicitors, acted for Messrs. Hepburn and Gale.

**OLD CHURCHES AND THE BUILDING ACT.**—At Southwark Police-court on Wednesday, John Bullers, builder, of Dockhead, was summoned by Mr. Bernard Dicksee, district surveyor, for fees amounting to £7 17s. 6d., in connection with certain alterations at St. Matthew's Church, New Kent-road. Mr. Wallace, barrister, defended. The complainant said he claimed, under the London Building Acts, to have jurisdiction over the alterations, which comprised an extension and raising of the chancel and an encroachment upon the passage in the nave. He admitted that these works did not affect the structure. Mr. Wallace contended that the church, being an old building, the complainant would have no jurisdiction over works which did not affect the building, and which did not increase the accommodation. Some limit must be placed to the powers of district surveyors, and some liberty of the subject must be allowed in such matters. After a lengthy argument, Mr. Fenwick reserved his decision.

**A SUCCESSFUL APPEAL.**—In the Court of Appeal, London, on Friday, Mr. W. N. Brims, contractor, Newcastle-on-Tyne, was successful in his appeal from Mr. Registrar Brougham, setting aside an order to serve a notice in bankruptcy under the Act of 1890 upon Sir C. M. Palmer, Bart., M.P. The appellant had done certain contract work in the construction of docks at Bilbao for the Spanish Government, Sir Charles Palmer and Mr. Martinez Rivas, a Spanish gentleman, being in partnership over the undertaking. Mr. Brims had obtained a judgment for £16,723 against the partners, and as a considerable portion of that sum still remained unpaid, he desired to serve notice of bankruptcy upon Sir Charles Palmer. Lords Justices Smith, Chitty, and Collins concurred in holding that the judgment debtor was entitled to do so, and allowed the appeal with costs.

**BLACKPOOL BUILDING LAWS.**—In the Chancery Division, on Friday, Mr. Justice Kekewich resumed the hearing of the case of the Attorney-General, at the relation of the Mayor, Aldermen, and Burgesses of Blackpool v. Siddall, by which the plaintiffs seek to restrain the defendant from bringing forward or permitting to remain erected certain buildings without the corporation's written consent in New-road, Blackpool, which was alleged to be a street within the Public Health Act, beyond the front main walls or buildings on the east side of the New-road. Mr. Wolstenholme, borough surveyor, Blackpool, gave evidence in support of the plaintiff's case, and in cross-examination asserted that what defendant proposed to do was illegal, and must be injurious to the inhabitants. New-road was a public highway, and led from Blackpool to Poulton. Mr. Bramber, building inspector to the corporation, and Councillor Heap having corroborated, this closed the plaintiffs' case. Counsel for the defence maintained that New-road was not a street within the meaning of the Act. The defendant's old buildings at Clifton Bank were not in New-road at all, and to enforce the building line as asked in this case would mean the confiscation of a large amount of property. His lordship, in giving judgment, held that New-road was a street within the meaning of the Act, and granted the injunction asked, ordering the defendant to pull down the buildings, the mandatory part of the injunction, however, not to take effect for three months.

The Prestwich board of guardians have adopted plans for adding casual wards to the workhouse at an estimated cost of £12,000.

The new nurses' home which is being erected behind the Leeds infirmary is expected to be completed before the close of the year. The new building will provide accommodation for 52 nurses. In addition to bedrooms, there will be a recreation-room, a sisters' room, a visitors' room, and a study. Mr. W. H. Thorp, of Albion-street, is the architect.

A meeting of employers connected with the building trade was held in the Albert Hall, Morecambe, on Tuesday week, to consider the advisability of forming a masters' association. Addresses on the advantages of federation were given by Mr. Tomlinson, Preston, the secretary of the Lancashire Federation; Mr. Gartsdale, Chorley; and Messrs. Parker, Ridd, and Sharples, Longridge. After some discussion, it was decided that an association be formed, and that Messrs. J. Scott, J. H. Brear, J. Gardner, J. Escolme, and A. Woodhouse be a committee to draw up the necessary rules. Mr. J. Edmondson was elected chairman, Mr. F. J. Baxter treasurer, and Mr. J. Willis secretary.

## STATUES, MEMORIALS, &amp;c.

**CAEDMON MEMORIAL.**—At a meeting of the Executive Committee held at Whitby on Saturday, Canon Rawnsley presented the design for the cross to be erected in the churchyard of St. Mary's, which had been prepared by Mr. Hodges, F.S.A., of Hexham. The design is based in scale and treatment upon the Ruthwell, Rothbury, Acca, and Bewcastle crosses. On one side appear in four panels, Christ, David, Hilda, and Caedmon; on the obverse the double vine. Within its spandril are figures of the six bishops trained in Whitby Abbey and Cuthbert and Bede. Below is carved an English rendering of the famous nine lines of Caedmon's Creation poem. The two sides of the cross are filled with a scroll of wild rose and apple, with birds and animals, symbolising the care for all life taught by the spirit of Christ. The design, with the estimate of the stone-carvers, Messrs. Beall, of Newcastle, was provisionally accepted.

## WATER SUPPLY AND SANITARY MATTERS.

**JOINT SCHEME OF WATER SUPPLY FOR DERBY-SHIRE VILLAGES.**—A meeting of representatives of the New Mills and Whaley Bridge Urban District Councils, and the Rural District Councils of Disley and Chapel-en-le-Frith, was held at Whaley Bridge on Friday for the purpose of adopting a joint scheme of water supply. Mr. Stirling, of Messrs. Stirling and Swann, engineers, described a scheme. It is proposed to make a large reservoir at Taxal with a storage capacity capable of supplying a population of 7,000 with 25 gallons per head per day, and capable also, with little extra cost, of being made to give double that population the required quantity. About nine acres of land would be required for the reservoir. Without branches the cost of the joint scheme, with mains, &c., would be £22,696 18s. 7d., or with the necessary branches £26,033 5s. Taxal would pay £1,224 0s. 1d., Fernilee £4,858 1s. 9d., Chapel-en-le-Frith £1,745 1s. 10d., Whaley Bridge £6,747 8s., Disley £1,361 6s., and New Mills £10,096 19s. 3d. Colonel Jodrell, M.P., had agreed to let a company or the joint councils have the water free until the scheme became a paying one for the districts served. A lesser scheme excluding New Mills was also submitted. The scheme was discussed at considerable length, and finally the meeting was adjourned.

**METROPOLITAN WATER COMMISSION.**—Sir Alexander R. Binnie, the chief engineer of the County Council, gave further evidence on Monday before the Royal Commission appointed to inquire into the supply of water to the Metropolis. He expressed his strong preference, in respect to the increased supply that would shortly be required, for the works being carried out by some public body rather than by commercial companies. Such a system would put an end to constant inquiries, such as had been going on since 1811, and would enable the public authority to carry out the suggestions of various commissions and committees. In the next place it would put London in a similar position to that which was at present occupied by most of the important towns of the kingdom. Again, according to all the authorities on the subject, London must have its present supply more than doubled in the next thirty or forty years. The present supply of water might be taken for the year 1896 at 198,000,000 of gallons per day. Its cost in capital expenditure had been £16,531,346, or at the rate of £83,492 per 1,000,000 gallons per day. If water were brought from Wales, it would be pumped into the present high-service reservoirs of the companies, and would thence gravitate to different parts of London. He did not think the expense of making the necessary connections between the works of the existing companies, if they should be purchased by the London County Council, would be very large. The Commission adjourned to Monday next.

The final audit of the account for the restoration of the fabric of Gloucester Cathedral was published on Saturday. The total sum raised, including the Freemasons' gift and a grant from the Ecclesiastical Commissioners, is £9,789.

The Finance Committee of Aberdeen Town Council had under consideration on Monday the question of the office and duties of the city architect. A report showing the amount of remuneration received by Mr. Rust, the present city architect, since he was appointed to the office, was submitted. Councillor Fleming moved that the committee recommend that a new official be appointed, to be called city architect and clerk of works, who will have charge of all the works promoted by the town council, and that he devote the whole of his time to the duties of the office. He suggested that the salary should not exceed £300. The previous question—that the office and duties of the city architect remain as at present—was moved, and this was carried by eight votes to two for Councillor Fleming's motion.

## Our Office Table.

Two new pictures have just been added to the collection in the National Gallery at Trafalgar-square. Both are portraits, one being that of Madame Vigée le Brun, painted by herself at the age of 27; it was hung on Friday in Room XVII.; the other has been given by the Rev. Alfred Gurney, and is by Mr. G. F. Watts, R.A. It represents the late Mr. Russell Gurney, Recorder of London, and long the member for Southampton. It will shortly be placed in Room XXI. in the English wing. To the Tate Gallery of British Art at Millbank two pictures have also been added during the past week. A body of subscribers have presented to the National Gallery through their hon. treasurer, Sir James Blyth, a picture by Mr. Frederick Goodall, R.A., entitled "The Ploughman and Shepherdess," exhibited last summer in the Royal Academy. The second is the portrait of Mr. G. F. Watts, R.A., by himself, which was bequeathed under certain conditions to the nation in 1892 by the late Sir William Bowman. The picture, which until recently has been on exhibition at Stockholm, has now been handed over by Mr. J. Fred Bowman to the trustees.

At Tuesday's meeting of the London County Council a special return was issued by the Finance Committee on the Works Department, being a statement of the whole of the estimated works commenced, completed, and certified, and of jobbing works certified since the change in management in December, 1896. It showed revised estimates amounting to £14,347, actual cost £10,681, amount of saving £3,665, or 25½ per cent. On jobbing works the schedule value was £25,308, and actual cost £23,150, a saving of £2,158, or 8½ per cent. The total saving was 14½ per cent. With regard to the Boundary-street works, where the difference of cost below the estimate was £2,995, the chief causes which enabled so large a saving to be effected were that, in consequence of other works being carried on within the same area, they were able to employ the same foreman, timekeeper, watchman, &c., on these as on other works, and by that means to save largely in wages each week, and they had the further advantages of retaining the services of men who had become accustomed to their requirements. The same advantages operated in the provision of water supply, lighting, and watching. The other works which this department was carrying out formed a partial protection, and they already had a quantity of hoarding on the ground, so that very little expense was incurred in this respect. On the other hand, had a contractor been employed for this work, the Council would not have benefited by these advantages. The department purchased some of the principal materials required at a much lower price than the current market rates. The Council would effect considerable economy if works were carried on continuously, keeping the staff, plant, and men uninterruptedly employed. After some discussion, the report was accepted without a division.

SOME progress is being made by the officials of the London County Council towards the preparation of a ground plan of London. The Corporate Property Committee stated on Tuesday that at the present moment no fewer than 2,276 estates, representing two-thirds of the area of the county, had been scheduled, and that a further 116 were waiting to be defined. This work had been accomplished for £1,972. On the last occasion when they reported, but three-fifths, or 1,804 estates had been defined. The average cost of doing the work had been 9½d. per acre.

A DINNER was given by the Central Association of Master Builders of London in the Blue Salon of the Trocadero Restaurant, Piccadilly-circus, on Tuesday evening, to entertain the President and Council of the National Association of Master Builders of Great Britain. Mr. William Shepherd, the president of the Central Association, occupied the chair, and was supported by Professor George Aitchison, R.A., P.R.I.B.A., Mr. J. Stevenson Jones, the president of the National Association, Messrs. Hampton W. Pratt, P.A.A., T. Blashill, F.R.I.B.A., Frank May, J.P., J. Bowen, J.P. (Birmingham), W. Holdsworth, J.P., W. Jessop, H. H. Bartlett, A. Krauss (Bristol), G. H. Barnsley, T. F. Rider, J. Howard Colls, F. J. Dove, J. C. White, Howell J. Williams, H. Seth-Smith, Henry Holloway, Stanley G. Bird, Charles Wall, Joseph Randall, L. J. Maton, E. Hind, J. A. S. Hassall,

R. S. Henshaw (secretary Central Association), &c. A selection of music was performed under the direction of Mr. Herbert Schartau. The principal toasts were: "The Royal Institute of British Architects," proposed by Mr. F. J. Dove, and acknowledged by Professor Aitchison, the president; "The Architectural Association," proposed by Mr. J. H. Colls, and responded to by Mr. Pratt, the president; and "The National Association of Master Builders," proposed by the Chairman, and also acknowledged by the President, Mr. Stevenson Jones, and by Mr. Rider, past-president. Mr. Charles Wall, of Chelsea, then gave the toast of "The Provincial Associations," Aldermen Holdsworth and Bowen replying. The health of "The Chairman" was proposed by Mr. J. C. White, and that of "The Visitors," proposed by Mr. Holloway and acknowledged by Mr. Blashill, the architect to the London County Council, brought the proceedings to a close.

ACCORDING to the *City Press*, owners of burnt-out property in the area affected by the Cripple-gate fire find that the provisions of the new Building Act will materially affect their net returns. On comparatively small warehouses they are called upon to incur a large additional expenditure, amounting in many cases to 25 per cent. extra upon the original cost, for which, owing to the fact that the obligations under the leases are running, they will receive no return for a dozen years or more. Another grievance is that the district surveyor orders them to do one thing, and the officer who represents the London County Council acts in quite a contrary manner, and insists on an entirely different course being taken. How to please both is a problem they have hitherto failed to solve.

THE mixtures, greases, and oils usually employed as a lubricant for plaster moulds have the disadvantage of being sticky or of easily attracting dust. According to Puscher, this drawback is avoided if stearic acid is used instead. Melt one part stearic acid in a glass by immersing the same in boiling water and add four to five parts alcohol (95 per cent.). Agitate the clear solution until cold, whereby a thin paste of very finely distributed stearic acid is formed, with which the moulds are coated by means of a painting brush. The spirit evaporates at once and leaves a thin layer of stearic acid, which admits of readily freeing the cast from the mould.

The London and North-Western Railway Company have decided to proceed immediately with the construction of the new station at Lancaster, the cost of which will be from £50,000 to £70,000. Negotiations for the land have been concluded, the corporation having arranged a transfer which will enable them to proceed with an important street improvement. The new station will be upon and slightly north of the present Castle Station.

The proposed Builders' Exchange for Halifax has now been successfully launched, the officers for the ensuing year having been appointed as follows:—President, Mr. Edwin Naylor; vice-presidents, Messrs. Schedeur Hartley, Isaac Firth, and William Oates; treasurer, Mr. W. Jelley; secretary, Mr. Alfred E. Dalzell.

The public library, Neath, is being warmed and ventilated by means of Shorland's patent Manchester grates, Shorland's patent exhaust roof ventilators, and special vertical inlet tubes, the same being supplied by Messrs. E. H. Shorland and Brother, of Manchester.

The hoarding which now hides City-square, Leeds, from public view is expected to be removed in about six weeks. The granite balustrade, which forms a circle 100ft. in diameter around the space where the equestrian statue of Edward the Black Prince is to stand, is almost completed. The concreting of the circle is finished, but the flagging outside the balustrade remains to be done. Around the balustrade eight small figures, representing alternately Night and Morning, are to be placed. Each figure will hold a 500-candle-power electric lamp. These figures are expected to be ready before the close of the present year. The plans for laying out the square were prepared by Mr. Bakewell, architect, of Leeds.

At the Railway Hotel, Weston-super-Mare, on Friday, the annual dinner in connection with the Master Builders' Association was held, the chair being occupied by the president, Mr. W. Dyer. The principal toast was "The President, Officers, and Association," proposed by Mr. W. H. Wooler, and acknowledged by the chairman, Mr. C. Addicott (vice-president), and Mr. W. H. Shorney (secretary).

## MEETINGS FOR THE ENSUING WEEK.

**SATURDAY (TO-MORROW).**—St. Paul's Ecclesiastical Society. Annual Meeting at St. Paul's Chapter House. 2.30 p.m.

**MONDAY.**—Society of Arts. "Decorative Bookbinding." Cantor Lecture No. 2, by Cyril Davenport. 8 p.m.

**TUESDAY.**—Institution of Civil Engineers. "Reservoirs with High Earthen Dams in Western India," by W. L. Strange. 8 p.m.

**WEDNESDAY.**—Society of Arts. "The Cinematograph," by Jules Fuerst. 8 p.m.

**FRIDAY.**—Architectural Association. "Hampton Court Palace," by John Belcher, F.R.I.B.A. 7.30 p.m.

Birmingham Architectural Association. "House Decoration," by L. A. Shuffrey. 6.45 p.m.

## THE ARCHITECTURAL ASSOCIATION.

FEBRUARY 4th. ORDINARY GENERAL MEETING. 7.30 p.m., Mr. JOHN BELCHER on "HAMPTON COURT PALACE" (Lantern Views).  
FEBRUARY 5th. FIRST SPRING VISIT. Members to meet at Lord Ribblesdale's house, corner of Norfolk-street and Green-street, Park-lane, W., 2.30 p.m.

E. HOWLEY SIM, } Hon. Secs.  
G. B. CARVILL, }

## Trade News.

### WAGES MOVEMENTS.

**ASHFORD, KENT.**—A movement is being made on the part of the men engaged in the local building trade to secure an increase of one penny per hour in their wages. The masters have been interviewed by the representatives of the men, and the result is that they have offered an increase of a half-penny per hour all round. It is not considered likely that the offer will be accepted, as the men still hold out for the penny advance.

**TAVISTOCK.**—As the result of a meeting at Tavistock on Saturday between representatives of the Amalgamated Society of Carpenters and Joiners from Plymouth and the master builders and carpenters in Tavistock, it was agreed that the men should work 5½ hours instead of 56 in the summer, and 51 in winter, and that the minimum rate of wages should be 6d. per hour, instead of 5d. This puts an end to anything that remained in the form of a strike, which originated on April 1 last.

### CHIPS.

At Friday's meeting of the town council of Stockport it was decided, after a long discussion, to erect a new and more adequate town hall, and the questions of a site and the probable cost were referred to a committee. It was also decided to erect a new fire-station on a portion of the Mersey Mill site, Heaton-lane, from plans and drawings prepared by Mr. John Atkinson, borough surveyor.

Mr. H. H. Law, Local Government Board inspector, sat in the Council Chamber, Birmingham, on Friday, to inquire into applications by the city council for sanction to borrow £10,000 for lunatic asylum purposes, and £12,510 for the erection of a refuse destructor at the Montgomery-street Wharf. Referring to the application for sanction to borrow £10,000 for lunatic asylum purposes, the town clerk said that the money was required for the purchase of 99 acres of land, which was destined to be the site of the new lunatic asylum.

A meeting of the harbour committee of the Weymouth Town Council was held on Friday, when the scheme for the erection by the Great Western Railway of new harbour and railway works at a cost of £200,000 was considered. Unsatisfactory features in connection with the new scheme were pointed out. The loss to the town by the diversion of the present harbour dues will be very heavy, and a strong effort will be made to secure compensating advantages. The company's Bill in Parliament will probably be opposed.

The Queen, it is stated, meditates making some improvements at Osborne. Her Majesty's architect has been in consultation with her, and has placed certain plans before the Queen in harmony with her suggestions. As a result the work will, in all probability, be proceeded with as soon as her Majesty has vacated the mansion for her next visit to Scotland.

The Local Government Board have issued an order sanctioning the application of the Portland District Council for power to borrow the sum of £35,000 for completing a scheme for supplying the island with water from Upwey.

It has transpired that at the election of Royal Academicians on Wednesday in last week there was a tie for the filling of the second vacancy, Professor Aitchison and Mr. Seymour Lucas gaining the same number of votes each—27. In accordance with traditional usage the president awarded his casting vote to the senior associate, thus electing Mr. Aitchison.

LIST OF COMPETITIONS OPEN.

Carlton, Victoria—Children's Hospital	£100, £50, £25	J. Nicholson, Hon. Sec, Pelham-street, Carlton, Australia	Jan. 30
Leicester—Motor Refuse Carts	Corporation	E. G. Mawbey, Borough Engineer, Leicester	31
Rugby—Public Work, Cattle Market		T. M. Wratlsey, Clerk, Rugby	Feb. 1
Eastleigh—Public Offices	50gs. (merged), 20gs.	Hy. White, Clerk, U.D.C., 19, St. Peter's-street, Winchester	7
Wolverhampton—Motor Vans	Public Works Committee	J. W. Bradley, C.E., Borough Engineer, Town Hall, Wolverhampton	7
Barrow-in-Furness—Technical Schools	£50 (merged), £20	The Town Clerk, Town Hall, Barrow-in-Furness	14
Port Elizabeth—Free Library (Assessors, Sir F. Blaine and R. H. Hammersley-Hunan—£22,000 limit)	100 Guineas, 50 Guineas	G. Oettle, Librarian, Port Elizabeth, S.A.	15
Winchester—Public Baths	£25, £15	Walter Bailey, Town Clerk, Guildhall, Winchester	23
New York—Sun Dial (Plaster Model)	500dol., 250dol.	Sec. National Sculpture Soc., 215, West 57th-street, New York	24
Newcastle-on-Tyne—New Infirmary (local Architects)	(No first) £150, £100, £50	Secretary Building Committee, Newcastle	Mar. 1
Berwick-on-Tweed—Police-Station (£5,000 limit)	Commission or £50, £25	R. Weddell, Town Clerk, Berwick-on-Tweed	14
Belper—Sewage Disposal Schemes	50 Guineas, 25 Guineas	Joseph Pym, Clerk, Belper	May 1
Stockholm—City Railway Stations and Junctions	£656, £498, £219	Consulate General, 27, Great Winchester-street, E.C.	Aug. 31
West Bangour, Linlithgowshire—Lunatic Asylum (limited to Scotch Architects)	£250, £200, £150, £100	Secretary, District Lunacy Board	—
Southampton—Fireproof Flooring, Warming, &c., Municipal Lodging Houses		W. B. G. Bennett, Borough Surveyor, Southampton	—
Royal Aquarium—Design for Poster	10 Guineas	Edgar S. Shrubsole, Royal Aquarium, London	—

LIST OF TENDERS OPEN.

BUILDINGS.

Great Burstead—Repairs to White Bridge	Billericay Rural District Council	C. Edgar Lewis, Clerk, Brentwood	Jan. 29
Long Ridge—Five Houses, Pitt-street	Co-operative Society	William Munford, 33, Guildhall-street, Preston	29
Killeter—Creamery		Charles Clarke, J.P., Auzheyarron, Castlederg	29
Burnley—Alteration of Premises at Central Club	G.U.O.F. Building Committee	Jas. Kippax, Secretary, Central Club, Burnley	29
Morley—Bakery and Stables, Fountain-street	Metcalfe and Bradshaw	Buttery and Birds, Architects, Morley	29
Pusey—Sunday School		Hodgson and Farrar, Architects, Old Bank Chambers, Bradford	29
Kidderminster—Rebuilding Out-Offices, Hume-street Schools	School Board	W. M. Roden, Clerk, Kidderminster	29
Hull—Play-Shed and Gymnasium at Grammar School	Corporation	A. E. White, City Engineer, Town Hall, Hull	29
Branderburgh, N.B.—Cottage		R. B. Pratt, Architect, County Bank House, Elgin	29
Cork—Nine Houses, College-road	John Kelleher	W. H. Hill and Son, Architects, 28, South Mall, Cork	29
Bath—Terrace, Newmarket-row	Markets Committee	C. E. Davis, F.S.A., City Architect, Bath	29
North Berwick—Additions, Free Church Manse		Geo. Nelson, Clerk, Quadrant, North Berwick	29
Paisley—Masons' Work (till May 15, 1899)	Commissioners	M. Moncur, Master of Works, Municipal Buildings, Paisley	29
Pontefract—Shop Front, Beast Fair	Mrs. Brook	Tennant and Bagley, Architects and Surveyors, Pontefract	29
Wolverhampton—Shelter, East Park	Corporation	J. W. Bradley, Board Engineer, Wolverhampton	29
Kirkcaldy—Six Shops and Fifteen Dwelling-Houses, Whytehouse Mansions		Robert Little, Architect, 4, St. Brycedale-avenue, Kirkcaldy	31
Hull—Rebuilding Swan Inn, Beverley-row	Whytehouse Estates Co.	Freeman, Son, and Gaskell, Architects, Carr-lane, Hull	31
Anfield Plain—Mineral Water Factory	Moss and Robson	D. M. Spence, Architect, Front-street, Anfield Plain	31
Port Glasgow—Story on Jean-street School		John Hood, Clerk, Port Glasgow	31
Shoreditch—Transformer Sub-Station, Worship-street	School Board	H. Mansfield Robinson, Vestry Clerk, Town Hall, Old-street, E.C.	31
London-derry—Three Houses, Nortland-road	Shoreditch Vestry	Wm. Barker, Architect, 3, Richmond-street, Londonderry	31
Clown—Additions to Schools	School Board	Rollinson and Son, Architects, 3, Corporation-street, Chesterfield	31
Tooting Common—Refreshment House	London County Council	T. Bell, Clerk, Council Offices, Spring-gardens, S.W.	31
Hull—Rebuilding Duke of Cumberland Inn	Moss and Robson	Freeman, Son, and Gaskell, Architects, Carr-lane, Hull	31
Cork—Pair of Semi-Detached Villas		W. H. Hill and Son, Architects, 28, South Mall, Cork	31
Tregaron—Intermediate School	County School Managers	M. Morgan, Clerk, Tregaron	31
East Han—Schools (for 1,645 Children), White Horse-lane	School Board	W. J. Brett, Clerk, Lichfield-terrace, Upton Park, E.	31
Camberwell—Refreshment House, Myatt's Fields	London County Council	T. Bell, Clerk, Council Offices, Spring-gardens, S.W.	31
Sutton-on-Hull—Bungalow and Villa		Freeman, Son, and Gaskell, Architects, Carr-lane, Hull	31
Ford—Re-seating Board-Room	Guardians of Stoke Damerel	Albert Gard, Clerk, 19, St. Aubyn-street, Devonport	31
Glasgow—Steward's House, Lodges, Entrance Gateway, Wat.r Tower, Storage Tanks, & Boundary Walls, Ruchill Hospital	Corporation	John Lindsay, Interim Clerk, City Chambers, Glasgow	Feb. 1
Manchester—Twenty-Six Cottages at Miles Platting	Improvement Committee	City Surveyor, Town Hall, Manchester	1
Southampton—Isolation Hospital, Mousehole-lane, Millbrook	Corporation	George B. Nalder, Town Clerk, Municipal Offices, Southampton	1
Bourne—Cattle Market	Warwick and Richardson	F. G. Shilcock, Architect, West-street, Bourne, Lincs	1
Paignton—New Buildings	Gas Company	F. W. Puddicombe, Secretary, 5, Victoria-street, Paignton	1
Market Bosworth—Iron Hospital	Rural District Council	W. M. Sykes, Surveyor, Market Bosworth	1
Llantrisant—Calvinistic Methodist Chapel and Vestry		The Crown Shop, Llantrisant	1
Tullyallen—New Church	Rev. Thomas Taafe, P.P.	William H. Byrne, M.R.I.A., Architect, 29, Suffolk-street, Dublin	1
Manchester—Thirty-Four Cottages at Miles Platting	Improvement Committee	City Surveyor, Town Hall, Manchester	1
King's Lynn—Purifying House	Gas Co.	E. G. Smith, Engineer, Gasworks, King's Lynn	1
Isle of Grain—Thirteen Dwelling-Houses	Coastguard	Director of Works Department, Admiralty, Northumberland-avenue	1
Manchester—Offices, Whitworth-street	Improvement Committee	The City Surveyor's Office, Manchester	1
Dudley—Grammar School and Master's House, St. James's-rd.	Governors of Grammar School	Albert Morton, Clerk to the Governors, 15, Birmingham-rd., Dudley	1
Liverpool—Padded-Room and Lavatories, Smithdown-road Workhouse	Guardians of Toxteth Park	J. Moulding, Clerk, 15, High Park-street, Liverpool	2
New Cross, S.E.—Alterations to North Lodge Stores	Metropolitan Asylums Board	T. Doucombe Mann, Clerk, Norfolk House, Norfolk-street, Strand	2
Bourne—Cattle Market		J. Clare, Architect, Sleaford	2
Dorling—Pumping-Station Buildings	Dorling Waterworks Co.	The Secretary, Dorling Waterworks Co., 72, High-st., Dorling	2
Sheffield—School at Daniel Hill	School Board	Hensoll and Paterson, Architects, 18, Norfolk-row, Sheffield	2
Bourne—Blacksmith's Shop	Bourne Brewery Co.	J. Clare, Architect, Sleaford	2
Ascot—Additions, Station Hotel		S. C. Johns, M.S.A., Wallingford	3
Bristol—Alterations to Premises, Wine-street	L. Packham	Henry Williams Architect, 24, Clare-street, Bristol	3
Skegness—Laundry Buildings	Urban District Council	Thimbleby and Sons, Secretaries, Spilsby	3
Sandbach—Brick Tank at Pumping Station		W. Wyatt, Engineer, Bryndwr, Shrewsbury	3
Boston, Lincs—Wesleyan Sunday Schools		Gelder and Kitchen, Architects, 76, Lowgate, Hull	3
Mitchelstown—Medical Officer's Residence, near Galbally	Mitchelstown Guardians	Richard Fitzgibbon, Clerk, Mitchelstown	3
Halifax—Pair of Semi-Detached Villas, Savile Park		Medley Hall, Architect and Surveyor, 29, Northgate, Halifax	4
Penryn-neudraeth—Vagrant Wards at Workhouse	Festiniog Board of Guardians	Thomas Roberts, Clerk, Portmadoc	4
Keighley—Two Houses, Fell-lane		Barber Hopkinson and Co., Archts, Craven Bank Chmbrs, Keighley	4
Dewsbury—Two Shops in Northgate	Margam School Board	Holtom and Fox, Architects, Westgate, Dewsbury	4
Port Talbot—Schools for 800 Children	Guardians of Ateham Union	Frank B. Smith, Architect, Port Talbot	5
Cross Houses—Wards and Porter's Lodge at Workhouse		J. R. Withers, Architect, St. Mary's-court, Shrewsbury	5
Raphoe—Teachers' Residence	Industrial Co-operative Society	P. Gillespie, Schoolmaster, Raphoe	5
Earlestown—Premises, Crow-lane	Thos. Pattinson	P. M. Beesley, Architect, 2, Bridge-street, Earlestown	5
Broadley—Vicarage		T. H. Farrar, Architect, Fountain Chambers, Halifax	5
Crawcrook—Shop, House, and Cottage	James Pulsford	Michael Westgarth, 1, Barmoor-terrace, Ryton-on-Tyne	5
Marykirk—Napiet School	Industrial Co-operative Society	Burness and Dickson, Solicitors, Montrose	5
Exmouth—Additions to 15, The Parade		R. M. Challice, Architect, 9, Bedford-circus, Exeter	5
Sandbach—Alterations to House and Shop in Bond-street	Urban District Council	Alfred Price, Architect, Sandbach	7
Lochlea—Servants' Room at Invermark Lodge		Jenkins and Marr, Architects, 16, Bridge-street, Aberdeen	7
Cwmbran—Police Station	Standing Joint Committee	William Tanner, F.S.I., County Surveyor, Monmouth	7
South Acton—House and Laundries, Park-road North	Henry Hawkes	Edward Monson, F.R.I.B.A., 22, Buckingham-st., Adelphi, W.C.	7
London—Shop and House, Mid-street	Urban District Council	John Alcock, Architect, Keith	7
Hipperholme—Offices, House, Store-Sheds, &c.		J. E. and E. H. Hill, Solicitors, 4, Harrison-road, Halifax	7
London—Enlargement of Fire-Engine Stations in Heath-street	London County Council	C. J. Stewart, Clerk, Spring-gardens, S.W.	8
Hampstead, and Simpson-street, Battersea	Coastguard	Director of Works Department, Admiralty, Northumberland-avenue	8
Hove—Three Dwelling Houses	Urban District Council	W. H. Whitfield, Clerk, Broadway, Wimbledon	8
Wimbledon—Electric-Lighting Station and Chimney Shaft		James Young and Co., Architects, 62, Market-street, Bradford	9
Saltire—Four Houses	Guardians of Sunderland Union	J. W. Hodgson, Clerk to Trustees, 17, John-street, Sunderland	9
Sunderland—Infirmary Buildings at Workhouse, Hylton-road		William H. Byrne, Architect, 20, Suffolk-street, Dublin	10
Kilbeggs—St. Columba's Industrial School	St. Mary Islington Guardians	Edwin Davey, Clerk, St. John's-road, Upper Holloway, N.	10
Highbate Hill, N. Infirmary (for 800 patients), &c.	Coastguard	Director of Works Department, Admiralty, Northumberland-avenue	11
Dungness—Eleven Houses, &c.		John Forrest, Architect, 120, High-street, Forres	11
Findhorn—Villa	Carmarthen County Council	Thomas Jones, Clerk, County Council Offices, Llandovery	14
Llangathen—Stone Bridge, Dryslwyn Ford	School Board	J. T. Meredith, Kidderminster	14
Rowley Regis—Alterations at Tidvale Board School	Edmonton School Board	John Moule, Clerk, School Board Offices, Upper Edmonton	15
Lower Edmonton—Eldon-road Schools	John Binns and Sons, Ltd.	James Hartley, Architect, Exchange Buildings, Skipton	15
Cowling—Warehouse to Croft Mills			

# THE BUILDING NEWS

AND ENGINEERING JOURNAL.

VOL. LXXIV.—No. 2248.

FRIDAY, FEBRUARY 4, 1898.

## NEW SITES AND BUILDINGS.

IN a short time many of the old landmarks in the Metropolis will have disappeared, or will assume such new faces as hardly to be recognisable. The formation of a new street, the reclamation of a waste site, or one cleared by fire, are processes that have gradually robbed us of many historic sites and buildings, which in some cases might have been saved or snatched from the building speculator. A slight detour in the line of a new route might often save an historic building. An old square or courtyard like Staple Inn is worth preserving for the picturesque character or quaintness of its own which cannot be substituted by anything new, any more than an old oak can be replaced by a sapling. By some fatality or spirit of mischievous interference, the line taken for a new route is made to intersect an old property because something is to be made out of the ground that will largely help to float the scheme, or to remunerate the promoters. It is a little Klondyke to them. The same sort of enthusiasm which is prompting the Canadian Government to open up a route through the Dominion to the Yukon Goldfields, is the motive power in making new routes to centres where an open space like a little gold mine is to be found. This is the fever that is just now raging amongst property holders and company promoters in London. Wherever there is an historic site or old inn which has long been a source of pleasure to the lover of "picturesque London," there the vultures for easy gain are found to gather. No reserved site or historical point of vantage is safe from the greed of these speculators. Happily for the inhabitants of London, and those who value old sites and buildings, we have philanthropic bodies and individuals who, by agitating against these schemes for plunder, have helped to secure the much-prized public spaces or gardens for future generations, or have laid them out for recreation. How many sites and buildings would have disappeared during the last decade or so if the City Commissioners and London County Council had not secured them, it would have been sad to relate. These remarks are not without significance when so many schemes for rebuilding are contemplated. The General Purposes Committee of the London County Council are instructed, we believe, to keep a register of buildings of historic or architectural interest. A committee for the Registration of Old Memorials, including members of societies interested in the subject, have been engaged for some time in registering and collecting drawings of old buildings. Whether the results have been printed or not, with plans and drawings of old and interesting buildings, we cannot say; but these are absolutely necessary, and the Council ought not to lose the opportunity that at present exists. The Council ought to have power to purchase or contribute towards the cost of preserving any important site or historic building. The object they should have in view is the maintenance, at least, of any architectural or historical character that attaches to a locality, and in rebuilding old premises and neighbourhoods some regard ought to be given to the aspect and associations, if possible. Probably, in a few instances, it may be an advantage to change the old environment; but this ought to be done with some care, and without shocking the feelings and sympathies of old inhabitants. How many have cause to complain of

the orders for demolition and rebuilding in the Metropolis. Old tenants, who have expended large amounts in alterations and improvements to their premises, have been refused a renewal of their lease; in other cases, buildings of an offensive kind, huge dwellings in flats, have been erected close to dwellings, and suburbs once residential have been turned into places of business. We may mention many suburbs in the West-end and South which have been thus degraded. Let us take a few instances.

The London County Council lately agreed to an expenditure of over £200,000 for widening Long-lane and Tabard-street, Southwark, and the continuation of the latter through St. George's Churchyard into Borough High-street. Here we have a locality associated with Marshalsea Prison and "Little Dorrit." The site has undergone many changes, though not long ago a pedestrian might have seen a block of houses back to back, part of the male debtors' side, and the chapel of the later Marshalsea gaol. It is hardly pleasing to think of this ancient part of Southwark so completely changed as not to be recognisable, and the style of the buildings painfully modernised. Another large sum is to be expended, we believe, in widening Southampton-row, whenever that scheme comes off.

What will be done with the large area, now a mere waste of demolished houses, extending from Drury-lane to Catherine-street? Why should hundreds of working men and women have been turned adrift months before new buildings are erected? At present this wasted area is rather a danger to the neighbourhood, where all kinds of refuse can be thrown. Not long ago the Parks Committee of the County Council reported upon the part of this site a churchyard described by Dickens in "Bleak House." This ground is on the north side of Russell-court, and south of Drury-lane Theatre or Vinegar-yard, and was laid out as a playground by the Public Gardens Association, and kept up till lately by the London County Council. The owner of the fee is the Rector of St. Mary-le-Strand, and the County Council has no option in the matter. The Duke of Bedford, we believe, has acquired the land for the purpose of making a road from Drury-lane. The loss of the old playground will be felt. Why the delay in turning the area to useful account—say as a ground for recreation, or, at least, some portion of it? We should be sorry to see it all built over. Between Long-acre and Bow-street Police-court important new buildings have been erected for offices and business premises, much improving a very crowded and unsavoury neighbourhood. The buildings are broadly and picturesquely treated in red brick and stone. A gabled end faces Bow-street, and an arcaded basement in stone for shops is built. The main frontage extends eastwards and ends in Drury-lane, facing the police-court buildings. This elevation is broken by a corner octagon with flat cupola and by lofty gables and roofs with dormers. The brickwork is quite plain, with gauged brick arches over windows, and dressings; bold projecting door-heads, with inserted shell tympana resting on stone corbels, are over the doorways; the windows are plain sashes, divided into panes, and a strict Georgian character is given to the buildings—quite a pleasant relief to the many other instances in which the old character has been replaced by modernised ornamental buildings of a purely commercial kind. Other opportunities present themselves of preserving a little quaintness and picturesque character to new building on sites of historic interest, if only the architect can be found for the emergency.

Then we have the Parliament-street improvement, already commenced by the pulling-down of old houses on the north side. Here a splendid site for new build-

ings will be presented—or one suitable for London's Municipal offices. The question as to style seems one that ought to have consideration. On the same line of thoroughfare we have a range of palatial buildings like the Home and Foreign Offices, Treasury, Admiralty, &c.—all in some phase of Italian Renaissance. These ought to give the key-note if we wished to preserve any homogeneity. We know what the municipal authorities of Paris or any other Continental city would do in the circumstances. Having the opportunity of continuing the same width, they would bring into unison the whole frontage, the extreme ends or junctions being accentuated by features. But this is not the way our London County Council or their predecessors work. They do not acquire a whole block of old premises, but leave them to drop in one by one; instead of a general plan, elevation, or scheme of frontage being laid down beforehand, every purchaser or lessee can build as he likes, so long as he does not transgress the Building Act. We do not get a perfect scheme, but a patchwork reconstruction—here a little, and there a little, but without any unity.

A very important scheme for the rebuilding of a squalid and densely-built area in Westminster has been proposed by a private company. The site lies to the south of the Houses of Parliament. The boundaries are Great College-street and Little Smith-street on the north, Horseferry-road on the south, and Marsham-street and the Thames on the west and east. The company propose to remodel the whole area—the old warehouses and wharves next the river will be swept away and a portion of the foreshore taken in for the continuation of the Victoria Embankment from Victoria Tower Gardens to Lambeth Bridge. A broad avenue 90ft. wide from Abingdon-street will run in a direction parallel to the Embankment, and replace Millbank-street in a continuation with Grosvenor-road, and another cross street at right angles will be made from Great Peter-street to the avenue. Smith-square, with its curious church of St. John's, will be made a feature in this scheme. Here we have a grand opportunity for a river boulevard. The County Council workmen's dwellings scheme on the site of Millbank Prison is important. The remodelled area ought to be worthy of the traditions of the neighbourhood, with Lambeth Palace on the opposite side of the river. A great deal will depend on the design and construction of the blocks which are laid down in the scheme—an element often sadly overlooked.

Other sites will shortly be transformed. Leicester-square is undergoing the process on the north side, and the approach from Charing Cross-road has been widened and rebuilt. Much remains to make this centre worthy of its position. Cripplegate, the area demolished by the late fire, may, perhaps, be reconstructed with wide east and west thoroughfares, connecting London-wall with Smithfield. Jewin-street may be widened to 60ft., and other streets remodelled. The Elephant and Castle site is being demolished, to be rebuilt as we have lately shown. The widening of Tottenham Court-road at the Oxford-street end is proposed under the Improvements Act. A block of houses on the east side of Bozier-court is to be swept away to widen this part of the road, and prevent the block of traffic. The widening of the Strand by the removal of the island of houses between St. Mary-le-Strand and St. Clement Danes is also authorised. Other improvements are contemplated, such as the widening of Southampton-row between High Holborn and Theobald's-road, to a width of 80ft.—a very important route. These widening schemes are absolutely necessary, from the growth of traffic.

There appears to be a mania for demolition among many of the City wards, under the

doubtful name of "improvements." When a fire devastates a large area of buildings, as it did in Cripplegate, there is a good excuse for rebuilding and improving by widening the streets; but it is not so when a City authority, like the Bridge House Estates Committee, propose a wholesale demolition of houses in Finsbury Circus and London Wall, merely for the purpose of increasing the income of the estate, disregarding the interests of old tenants, and the outlay they have made on their premises. Large sums of money are spent by tenants who reasonably look for a renewal of their leases; but the ground owners often take no notice of those improvements, and rebuild simply with the object of securing larger rents.

Not only are new sites being opened up, but many of the older streets are beginning to wear quite a new aspect. The old haunts are disappearing, making place for loftier and larger buildings. These are not always improvements. Pretentious-looking buildings are elbowing out quiet and unostentatious structures, which had the merit at least of being comfortable within and substantial. In the old squares and streets of Bloomsbury and Mayfair the dull Classic exterior is gradually being superseded, and in some cases remasked, by more pleasing brick façades. At Harrington Gardens and Bayswater, several new brick houses have been erected from the designs, amongst others, of Messrs. Ernest George and Peto, Mr. Norman Shaw, and Mr. F. B. Wade, and at Queen's Gate and Sloane-street we find a few exceedingly well-treated red-brick designs, in which the architects have produced an effective brick style from simple Classic features. Could we insure this class of architecture in our business thoroughfares instead of the obtrusive and bizarre of the modern commercial builder, we should have less cause to grumble at so called street improvement.

#### AMENDMENTS TO THE LONDON BUILDING ACT.

NUMEROUS decisions have been given by the High Court upon the London Building Act which have seriously hindered the administration of the law, and have encouraged the proceedings of those who wish to evade the spirit of the Act. District surveyors have found it very difficult and hazardous to administer certain provisions, especially those relating to dangerous structures. We lately referred to one case of this kind, in which the appeal against the magistrate's decision was dismissed, and in which the High Court declared the summons taken by the Council was wrong, and that they had not made reasonable inquiry to discover the owner. These adverse decisions have made it urgent for the L.C.C. to propose amendments to the Act, and the committee entrusted with this business have lately reported upon the subject. They refer to certain decisions which have rendered the working of the Act very difficult. One of these decisions we have noticed in a recent article *re* Mead, a Metropolitan magistrate, when he appeared to show cause against a rule for a *mandamus* why he should not hear and determine a summons under the Act with regard to a dangerous structure, the question being whether a summons under section 107 could be properly served by being affixed to the premises only. The summons was addressed to the "owner" of the premises merely, who did not appear. The authorities then proposed to proceed in his absence, on proof that the summons had been affixed to premises. The owner was unknown, but it appears no steps were taken to discover him, and the Council thought that service under section 188 (1) was sufficient. The magistrate thought the service of summons addressed to the "owner" was a notice the service of which is provided for

by the Summary Jurisdiction Act, and must be served personally—even if not, he said reasonable diligence had to be exercised in discovering the owner, and therefore he held there had been no valid service of the summons. Mr. Justice Wright thought if, after reasonable inquiry, the owner could not be found, the procedure under section 188 was applicable; but in this case they had not made sufficient inquiry, therefore the application against the magistrate failed. The Council had first to prove inquiry, then the failure to find the owner, and that the premises were empty. As the report of the committee says, this decision materially affects the proceedings against the owner of a dangerous structure. For section 188 is clear: it states that "If no person be found on the premises, then by fixing a copy thereof (notice) on some conspicuous part of the building to which it relates." Sub-section (3) provides that a "Notice to the owner or occupier of any premises may be addressed by the description of the 'owner' or 'occupier' of the premises (naming them) without further name or description." No wonder the Council refer to this decision, which is practically this: that if the Council made reasonable inquiry, and could not discover the owner, a summons could be served under section 188; but if they could show no evidence of such inquiry, their summons was invalid. How, it may be asked, can "reasonable inquiry" be proved? Is it necessary to establish documentary proof as to the ownership? The committee think that for the purpose of these proceedings as to who is owner, a search in each case for documentary proof is necessary to be made before a summons can be taken out. Imagine the trouble involved in such a search.

In the case of a dangerous structure, it should be dealt with promptly, which cannot be done if these inquiries have to be made. Under the old Act no such difficulty arose, as in all cases of dangerous structures, all documents in proceedings could be served on some person on the premises, or otherwise by affixing them thereto. The importance of expeditious action in these cases has been proved over and over again; and the committee mention a case where, owing to a magistrate refusing to adjudicate in consequence of some informality in the service of the summons, two men narrowly escaped being crushed through the falling down of a part of a structure certified to be dangerous.

Then we have other sections called into question. The report refers to a case in which the magistrate dismissed a summons taken out against a builder for erecting a building in Moscow-road having the boundary of the forecourt at less than the prescribed distance from centre of road, because he held that, as the building itself was at the prescribed distance, no power to proceed was given by section 14, which merely applied to a building or structure erected within such distance. As the report says, this and the preceding section (13) make it clear that no part of the forecourt, boundary fence, or wall in front should be at less than the prescribed distance from centre of road; but the High Court dismissed the Council's appeal, and the magistrate's decision was confirmed. The Court admitted the intention of the section, but that in section 14 it was not expressed, and it was a slip which should be amended. Section 14 certainly does not read very clearly; it states that "any new building or new structure is erected at a distance, &c.," but it does not clearly apply to the forecourt or space in front, or to any boundary fence or wall. Section 200 is also desired to be amended. The report states that sub-paragraphs (a) (d) and (e) of sub-section 3 of section 200 should be taken out of that sub-section, and themselves be placed in a separate sub-section providing a penalty for offences which these paragraphs deal with. One

relates to the general line of buildings, and the other to wooden and other structures. These sub-sections should not have been included in the sub-section of which they now form part. Section 13 (5) is also taken exception to. It provides that no dwelling-house to be inhabited by the working class shall, without consent, be erected or re-erected within the prescribed distance to a height exceeding the distance of the front of, or nearest external wall of, such building from the opposite side of such street, &c." The amendment proposed is that no working-class dwelling shall be erected within 20ft. from the centre of the street or way on which it abuts, which was clearly intended, although the section does not set out the intention. Other sections which we have noted from time to time in the Act are ambiguously worded, and may often be turned to the disadvantage of the Act by unscrupulous builders; but those we have mentioned have been fruitful of litigation, and the London County Council have prudently taken the course they have in the interests of justice.

#### THE SOCIETY OF ARCHITECTS.

THE ordinary monthly meeting of the Society of Architects was held at St. James's Hall, Piccadilly, W., on Thursday evening in last week, Mr. T. Walter L. Emden, J.P., L.C.C., the President, in the chair.

##### ACCOUNTS FOR ARCHITECTS.

The following paper on this subject was read by Mr. HENRY CALDER MARSHALL, F.C.A.:—When my friend Mr. Henry Adams wrote to me asking if I would read a paper to the members of the Society of Architects, I felt very much inclined to refuse the invitation, wondering what there could be of mutual interest to the two professions, so I asked myself the question, and the answer was suggested: "As accountants live in houses designed by architects, so surely architects must or should keep their accounts on lines drawn up by an accountant," and in lively hope of gathering some useful material upon which to build up the fabric of accounts, I called upon two architects of my acquaintance. In reply to my questions as to how they kept their accounts, and what books they made use of, Architect No. 1 replied, "Accounts! books! Oh, yes! I have my bank pass-book and keep a letter-book: now, what more can I want?" Said architect No. 2, "I keep a letter-book and have my bank pass-book, and they are quite enough for me." I feel sure that there are very many professional men who keep no accounts at all, or who have a system of accounts somewhat similar to my friends', consisting of a banker's pass-book and a letter-book, totally inadequate either to the requirements of their business or even as a record of their household and personal expenditure. I would, therefore, call your attention firstly to the necessity and advantage of keeping proper accounts; and, secondly, to a simple system of accounts, suitable for the profession of an architect. Firstly, then, as to the

##### NECESSITY AND ADVANTAGE OF KEEPING PROPER ACCOUNTS.

Amongst other purposes, accounts, proper and correct, may be required for the following:—(a) Showing the amount of business done, for the purpose of admitting a new partner or for partnership adjustments; (b) showing the profits for the purpose of Income-tax, or for production to the assessors or commissioners; (c) for production to bankers or others in the case of requiring a temporary loan; (d) for production (if necessity requires it) in the law courts; (e) for showing profits, in order to arrive at the value of the goodwill, and for ascertaining the amount of outstandings, for the preparation of the accounts for probate, or for the administration of an estate in the case of intestacy; (f) and last, though not least—but let us hope it will never be required by anyone here this evening—for the purpose of the deficiency account under the Bankruptcy Act. Let us now deal with each of these questions *seriatim*.

##### PARTNERSHIP ADJUSTMENT.

(a) Suppose an architect in practice finds his business increase in such a way that the work becomes too much for him. He requires a



partner to bring in a certain amount of capital, and to relieve him of some part of the work. The architect, knowing that he has a good and well-established connection, is not particularly anxious to let anyone come in and take a share of his hard-earned business for nothing, so decides to make the incoming partner pay a good round sum for the goodwill, and arbitrarily fixes an amount. The incoming man demurs at the figure asked, and inquires how it has been arrived at. "Oh!" says the architect, who, like my friends, relies on his bank pass-book, "look at what my takings have been." And so he takes the total of the "payments in" side of the pass-book, quite oblivious to the fact that there might be items received in the business that have not been paid into the bank, and, *vice versa*, there might be sums paid into the bank that do not pertain to the business; there might also be loans which would go to swell the total, without really, of course, being takings of the business; there might, also, be amounts of cheques returned for re-endorsement and paid in a second time, and above all the pass-book might be wrong; bankers' clerks, like other men, are not infallible. On the other side there might be loans repaid and cheques paid in but returned for endorsement, and certainly, any cheques that have been drawn, but not presented, would not appear in the pass-book at all. The banker's pass-book is all very well and useful for showing the state of your banking account at any given date, but for no other purpose. It cannot take the place of a properly drawn up and correctly kept cash-book. The incoming partner objects to taking only the pass-book figures, so an accountant is called in, who with a great deal of perseverance and at a considerable expenditure of time, and at the expense of the architect, produces an account by analysing the pass-book and writing up a proper cash-book therefrom, and from the counterfoils of the paying-in book and cheque-book, and going carefully and systematically through the letter-book, and writing up commission-book, &c., from it. This account shows the profit to be considerably less than it was thought to be, and, much to the chagrin of the architect, the negotiations fall through. Now had there been an adequate system of accounts showing properly the takings and the net profits of the business, correct figures would have been submitted in the first place to the proposed incoming partner, and the negotiations would probably have been carried through to the satisfaction of all concerned. Of course, where a partnership has already been entered into, it is more than ever a necessity to keep true and correct accounts, and to have a proper system of bookkeeping. Do we not often hear of disputes and disagreements between partners, and of final adjustments of partnership accounts? You will quite see that with only the pass-book before us we get no information on the following points essential to the making up of a correct balance sheet and profit and loss account:—(1) Money owed and owing at the commencement of the financial year. (2) Money owed and owing at the close of the financial year. (3) Business in hand, both at the commencement and end of the year. (4) The separation of capital and revenue accounts, and the raising of accounts for the depreciation of leases, furniture, &c., also the reserve for bad debts. It is clear, therefore, that the pass-book does not have a very prominent place in a system of bookkeeping. It is a useful book, but only in a subsidiary way, as a means of showing the state of your banking account, and for reconciling therewith the balance of cash as shown in your cash-book, but it does not show either the gross takings or net profits of your business.

#### INCOME-TAX ASSESSMENT.

(b) Accounts may be required for the purpose of showing the profits for Income-tax or for production to the assessors or commissioners. How many complaints we hear on all sides of the iniquity of the Income-tax and the unreasonableness of the assessors and commissioners. Of the iniquity of the tax I have nothing to say—it has been imposed and we must submit, cheerfully if we can. There is not a single individual who would not rather be in a position to pay the Income-tax collector a larger sum than he already does. With only a pass-book I do not see how the Income-tax return can be properly filled up, and the ratepayer stands a chance of cheating either himself or the Government, if he relies upon getting his information from that source alone. The pass-book might contain dividends from

which the tax has already been deducted, and he would be paying twice over—a thing nobody ever wishes to do. If you have a properly drawn-up balance sheet and profit-and-loss account before you, the matter becomes much easier, and should you be called upon to appear before the Income-tax authorities you will have some reliable data to go upon, especially if your accounts have been made up or audited by a duly qualified accountant.

#### TEMPORARY LOANS.

(c) Accounts may be needed for production to bankers or others in the case of requiring a temporary loan. It may be that a time comes when financial assistance is required to tide over some temporary difficulty—the architect naturally turns to his bankers for such assistance. The first question that will probably be asked is: "Where are your accounts?" If the answer is "Oh, I keep none, I rely on my pass-book," there is every likelihood that he will be politely told that the money cannot be advanced. See in how much better a position the man is who can produce a properly drawn-up balance sheet and accounts, especially if the figures have been verified by a chartered accountant; even if the profit and loss account only show a small margin of profit. The banker sees that his client is a careful man. In the balance-sheet he finds a statement of his client's liabilities and of his assets, and can judge therefrom as to his solvency, and consider whether or no it would be prudent to make the loan. (d) Accounts may be required for production as evidence in the law courts. In such a case how awkward it would be if you had only a bank pass-book to produce, as nothing satisfactory can be got from it. You may, through not having proper books, lose your case, and retire from the court a wiser and a sadder man, determined, perhaps, to keep your books on some proper system, and not to rely any longer on the broken reed of a pass-book.

#### PROBATE.

(e) Accounts may be required for showing profits in order to arrive at the value of the goodwill, and for ascertaining the amount of outstanding for the preparation of the accounts for probate or for the administration of an estate in the case of intestacy. We appoint our friends executors of our wills; but do we, at the same time, try to ease their work by having our accounts in such order that, when we are called to "join the great majority," the work we leave our executors to do is comparatively easy and straightforward? Not if we only leave them a bank pass-book and letter-book, together with a chaotic mass of vouchers and papers to wade through. Poor executors! ill requited by the legacy of twenty-five or even fifty guineas mentioned in the will.

#### BANKRUPTCY.

(f) Accounts may be required for the purpose of the Deficiency Account under the Bankruptcy Act. The Deficiency Account is to the perplexed and harassed bankrupt the most unsatisfactory of all the forms he has to fill up. It is so difficult to account for the disposal not only of your income but of your deficiency—that is, the difference between your assets and your liabilities; even with properly-kept books it is no easy task, and woe betide you when you appear before the Official Receiver with an unsatisfactory deficiency account. Then there is the penalty attached to the neglect of keeping a proper system of accounts. The Act provides that under certain conditions, and on proof of certain facts, the Court shall suspend the discharge of the bankrupt. One of the facts reads as follows:—"That the bankrupt has omitted to keep such books of account as are usual and proper in the business carried on by him, and as sufficiently to disclose his business transactions and financial position within the three years immediately preceding his bankruptcy." The meaning of this is that his books must be kept in such a way as to show at once, without the necessity of investigation by a skilled accountant, the state of his business. So far I have been trying to prove by a negative argument, if I may so term it, the advantages of keeping proper accounts, or I should say, the disadvantages of not keeping them—let us in a few words try to prove the same by a positive argument. We all like, I take it, to know how we are going along, what profits we have made during the year, so that we may perchance be able to launch out a bit, or put by something for a rainy day, or indulge in some extra luxury. How much

more we enjoy these things when we know the money is really earned and that our accounts are all correct! Besides, without an adequate system of bookkeeping, how can we look after our business efficiently, or know all the necessary details? Should, however, fortune frown on us, and our accounts show a loss instead of a profit, how much better it is to face the difficulty and to know the worst at once. In France and other countries where the Code Napoléon prevails, it is obligatory for everyone in business to keep proper books, and not only so, but in the case of one book, "the journal," each page is numbered and stamped as *visé* by the President of the Tribunal of Commerce, the mayor or other authority. No blanks, erasures, tearings out, or additions of pages are allowed, and you are only permitted to have one journal at a time, which when finished is so marked before a new one is allowed to be commenced.

#### ARCHITECTS' BOOKKEEPING.

Let us now turn to the second part of our subject—"A simple System of Accounts suitable for the Profession of Architects"; but before doing so, I would very briefly say a little on the rudimentary principles of bookkeeping. What is bookkeeping? It may be defined as the art, science, or method of recording the financial transactions of a business or person so as to show at a glance, at all times, the value of the whole estate or capital, and each of its component parts, in a clear and concise manner. It shows whether capital has been increased or diminished, and by what means such gain or loss has been effected, and also the state of the account between the professional or business man and the person or persons with whom he has transactions. The component parts of an architect's business may be summed up as follows:—Cash (either at bank or in hand), fees (commission or otherwise), perhaps bills and debtors, lease, furniture, &c. These, after deducting creditors and other liabilities, form the capital or estate—and it is to show how these can be exhibited in a way that shall be at one and the same time both comprehensive and concise that I am here this evening. There are two systems of bookkeeping, one named "single entry," and the other "double entry." We will leave the first or "single entry" alone altogether, as being incomplete and unsatisfactory, and deal only with the system called "double entry." But do not run away with the idea that "double entry" means double work. It does certainly entail a little extra work, but this is far more than compensated by the "double entry" being both correct and in every way more satisfactory. There are two sayings or axioms in connection with bookkeeping by "double entry" which cannot be too strongly reiterated. These are: "Every debit requires a credit" (and consequently "Every credit requires a debit") and "In debit out credit." The first is the foundation of the system, and the second is a short and trite way of explaining that a man should debit himself with all he receives, and credit himself with all he gives out. The page to your left hand in a ledger is called the debit side, and that on the right the credit side; and it must not be forgotten that every entry on the one side must have a corresponding entry on the other side, either in a single amount or in an amount made up of the several items. The totals of all the entries on the debit side should agree with the totals of all the entries on the credit side. In one of our ablest works on bookkeeping, the writer says: "Bookkeeping creates nothing, it merely records transactions as between a giver and a receiver, the giver (as an individual or an aggregate) being credited with what he gives, while at the same time the receiver (as an individual or an aggregate) is debited with what he receives, and thus the balance is always kept equal" (Gérard van de Lindes' "Bookkeeping," page 2). And so we come back to our quotation, "In debit out credit." Let me give you an example. Our architect renders a bill of costs; what goes out and what comes in? The architect has given out his services, therefore the amount at which he values his work is placed to the credit of fee account, and the client to whom the bill is sent becomes the debtor, so we debit his account with the amount. Now, what happens when the account is paid? The money comes in to cash, therefore cash is debited, it goes out of the client's account, therefore the client is credited with the amount. Again, you buy some goods; what comes in? The goods. Therefore you debit goods or purchases account

What goes out? Why, your indebtedness to the seller of the goods; therefore you credit his account with the amount. When you pay for the goods, what happens? You take the money out of your bank; therefore you credit cash and you put it to the seller's account, therefore you debit him. Take the case of bills receivable. A man owes you money; he is debtor in your books for the amount. He gives you a bill, at say one month: that bill is a bill receivable. You say he has given me the bill in discharge of the debt, and until the bill becomes due he is no longer my debtor, therefore you credit his account with the amount, and as every credit must have a debit, you debit, what?—bills receivable, for it is this account that now owes you the money. When the bill is paid, you debit cash and credit bills receivable. Take the converse: you owe money and give a bill at, say, one month. This bill is a bill payable. The client to whom you gave the bill was a creditor in your books, but directly you gave the bill he ceases to be a creditor until the bill becomes due. So you debit his account and credit bills payable, and when you pay the bill you debit bills payable and credit cash. Bear in mind that there is always a *raison d'être* in all these entries. Leaving the matter of bookkeeping in the abstract, for the time being, we will turn our attention to what I would consider a satisfactory system for an architect's office, and, in doing so, will you kindly imagine that I have been called in by a firm of architects (who up to this time have only had a letter-book and bank pass-book) to arrange a scheme of bookkeeping for use in their office. They wish me to provide for all contingencies, and to frame for them a very complete system. They are not frightened at detail, being accustomed to that in the work of their own profession. I can find no book dealing with this special work on the shelves of our library, so I and my partners put our heads together to do the best we can for our clients, keeping the work as simple as possible, and remembering that we shall have to audit the accounts at the close of the year. We have already been in and analysed the pass-book, and have gone through their letter-book, and have been able, with the aid of various vouchers, invoices, &c., to draw up a statement of assets and liabilities to form the basis of the new system. There are

FOUR IMPORTANT MATTERS

taken into consideration in arranging the books:— (1) Bookkeeping as between the work or commission and the client. (2) Bookkeeping as between the work or commission and the architect. (3) Bookkeeping as between the client and the architect. (4) Bookkeeping as between the architect and his partners, or the internal work of the architect's office. I will now give you a list of books, and I hope you will not be staggered at the number. I do not say that they are all absolutely necessary; but, as you will remember, I was called in to prepare a scheme for a very complete system. Special books: 1, instructions book; 2, register of plans and drawings; 3, specifications, estimates, and sub-contract book; 4, certificate book; 5, contract book. Financial books: 1, commissions book; 2, cash book; 3, petty cash book; 4, journal; 5, ledger—clients; 6, ledger—private. Subsidiary books: 1, register of letter—inwards; 2, postage book; 3, press-copy account book; 4, press-copy letter book; 5, wages book. Before entering upon particulars of each of these books, I would ask you to bear in mind the following

FUNDAMENTAL RULES,

which the firm of architects, at my suggestion, willingly acceded to:—(1) Every commission work or job to bear a distinctive name or number, corresponding to the number given to it in the instructions book. (2) Every penny of cash received in the business to be paid into the bank and not used for petty cash purposes. (3) All books to be closely written up—say daily. This is most important in the case of books of initial entry, such as instructions books, &c. (4) No account or letter to go out of the office without being press-copied in the book provided for that purpose. (5) No payment to be made out of petty cash without having a voucher for the same. (6) All vouchers, both for cash payments and petty cash payments, to be filed in numerical order. (7) No posting allowed from one ledger account to another, except through the journal. A plainly ruled foolscap book is all that is necessary for an instructions book. It should have an index, so that any entry can be easily referred to. In this

book are entered up under a distinctive number all the particulars of each work or commission that comes into the office, with rough sketches, notes, &c., from the client's instructions. It is not necessary to restrict each entry to one page, as, if the work is considerable, the particulars would occupy more space; thus, the particulars of building a church or town hall would occupy more space than those pertaining to alterations in a private house.

EXAMPLE OF ENTRY. No. 1.

CHURCH OF ST. ANDREW'S. Slumpton.

1st January, 1898. Called by request on the Rev. Robert Spalding, and received instructions to make plans and drawings for a new church, cost not to exceed £5,000. Viewed the site, and made rough ground-plan.

5th March, 1898. Submitted plans and drawings, met the committee, and arranged to make an alteration by the addition of a side chapel—and so on.

EXAMPLE. No. 2.

W. JOHNSON. Klondyke House, Goldborough.

4th February, 1898. Received instructions from Mr. Johnson that he wished to construct a billiard-room to Klondyke House, drawing plans and meeting surveyor and builder, &c.

This book is, as it were, a complete history of each commission, the closing entry being account sent in such and such a date, the want of such an entry showing that the commission is still open, and that it has not come into the financial books. The instructions book should be under the continuous inspection of the principal, and I would also advise that the architect have small memorandum books—one for each job, for facility in carrying about. In these would be jotted down

Dr. CASH BOOK. Cr.

Date.	Particulars.	Folio.	Discount.	Details.	Paid into Bank.

roughly notes, &c., for transcription into the instructions book.

REGISTER OF DRAWINGS.

No.	Date.	Name of Job.	Description.	No. of Drawing.	Date sent out.	Date Returned.	Remarks.

This is a very useful book, as by its aid the working-drawings of any building can readily be referred to without the necessity of turning over a pile of plans to search for the one wanted. A place for every drawing, and every drawing in its place, would be a good motto for an architect's office. A column is given in which to note the date and number of copies supplied to builder, as if more than one drawing is required an extra charge may be made. Specification, estimate, and sub-contract book: An ordinary guard-book (with an index), for gumming in the various specification and quantity sheets, which form the basis on which the estimates are prepared and contracts fixed; also for estimates and contracts themselves. If closely kept up and indexed, this book will be found most valuable. Certificate book: This is a counterfoil book containing the usual certificates, with builders' receipt form on the back. On the counterfoil should be noted the distinctive number of the commission, with details, showing amount of contract, amount certified, and balance.

CONTRACT BOOK.

Contract No.  
Name.  
Description of Building.  
Builder's Name.  
Contract Date.

Accepted Tender.	Name of Contractor.	Certified Instalment.		Commission.		Remarks.
		Date.	No.	Amount.	Rate.	

This will be found a useful book for showing the state of the work as between the contractor and the client. It is posted up from the instructions and certificate books—a page being given for each commission. It contains particulars of contract number, name, description, contractor's name, contract date, amount of accepted tender, instalments as per certificates, number, date, amount, commission. By adding the last columns it will be seen what the work has cost the client up to a given date.

COMMISSIONS BOOK.

Date.	Particulars.	Folio Account Book.	Folio Ledger.	Detail.	Total.

When an account is about to be rendered to a client, the architect ascertains from the contract book the amount of commission chargeable, or, if the work has never reached that stage, he refers to the instructions book, and ascertains from it what work has been done, and charges accordingly; the account is then copied in the press-copy account book, which thus becomes a book of initial entry. From there the accounts are entered periodically into the commissions book, giving the date, the name of the client, the folio from the account book, detail of amount, and total. From this book it is posted to the debit of the client in the client's ledger. At the end of the month the commissions book is added up, and the total placed to the credit of fee account, thus completing the "double entry."

In giving a ruling of this book, I remember the rule that every penny received is to be paid into the bank. The columns provided are, on the debit side, date, particulars, folio, discount, details of cash, paid into bank, and on the credit side, date, particulars, number of voucher, folio, discount, details, cheques drawn. All the items on the debit side are posted to the credit side of the ledger, and all the items on the credit side are posted to the debit side of the ledger. In the case of any discount being allowed to the client, it is entered in the discount column and the net amount entered in the details of cash column, the discount being posted to the client's credit along with the cash. At the end of the month, the total of discount allowed column is posted to the debit of discount account, and the total of the discount received column to the credit of discount account. It is not generally considered necessary to have an account in the ledger for "cash," as the cash-book itself serves for a ledger account, so that the total of the debit balances of the ledger plus the balance of the cash-book, if representing cash in hand and at the bank, should agree with the total of the credit balances of the ledgers plus the balance of the cash-book in the event of the banking account being overdrawn. To reconcile the cash-book with the pass-book we take the balance of the latter, and if in our favour we add any amounts paid into the bank, but not yet placed to our credit by the bankers, and deduct the amount of any cheques drawn but not yet presented. The balance should agree with the balance of the bank column in the cash-book, the balance of the details column representing cash in hand not yet paid into bank. If the rule is maintained that every penny received must be paid into the bank, it follows that the only way that money can be obtained for petty cash purposes is by drawing it out of the bank specially. It is as well to do this in round sums—say, sufficient to last a week. The ruling for this book shows cheques from bank, date, particulars, voucher number, total paid, and a number of columns for collating payments under different heads, such as drawing materials and stationery, office expenses and postages, wages and travelling, and special ledger accounts, this last having columns for folio and amount. The balance between cheques from bank and total paid columns shows cash in hand, the other

PETTY CASH BOOK.

Cheques.	Date.	Particulars.	Voucher No.	Total Paid.	Drawing Materials and Stationery.	Office Expenses and Postages.	Wages and Travelling.	Ledger Accounts.	
								Folio.	Amount.

columns are added, and the totals posted to the debit of the various accounts in the private ledger, except the special ledger account column, where the items are posted separately.

JOURNAL.

Date.	Particulars.	Folio.	Debit.	Credit.
-------	--------------	--------	--------	---------

This book is most useful, and yet it is one of the best abused books, perhaps because not thoroughly understood. Fundamental rule 7 states: No posting allowed from one ledger account to another except through the journal. Supposing an error had been made, and J. Smith debited with £100 instead of T. Brown, the journal comes in, and an entry is made:—

T. Brown, Dr. £100 0 0  
To J. Smith £100 0 0

For this amount posted to latter's account in error.

But it is not only in cases of error that this book is useful, but also in the analysis of accounts, and at the close of the financial year for making up the profit and loss accounts. In days gone-by it was customary for every transaction to pass through the journal, and well do I remember the time—now some 30 or more years ago—being seated at a desk in a merchant's office, journalising every item from the cash-book, petty cash-book, invoice book, account sales book, &c. Those were good old times—when every letter inwards and letter outwards were copied by hand into large and ponderous tomes. I don't know if this was all necessary, or whether it was arranged to provide work for us juniors to keep us out of mischief, or as a means for the improvement of our handwriting. We none of us liked it, but it had to be done, and I don't think any of us were the worse for the discipline.

Dr. LEDGERS. Cr.

Date.	Particulars.	Folio.	Amount.	Date.	Particulars.	Folio.	Amount.
-------	--------------	--------	---------	-------	--------------	--------	---------

I would advise two ledgers being used: the clients' ledger for all accounts with clients, and the private ledger for all accounts pertaining to the internal work of the office. The clients are debited with amount of bills from the commissions book, and any special amounts paid on their account, and are credited with amounts received and any discount allowed from the cash-book. The private ledger should contain such accounts as partners' capital and drawing accounts, fee accounts, the various accounts for expenses, profit and loss accounts, &c. This book is of a strictly private nature, and might well have a lock and key. In very large businesses it would be possible, and perhaps desirable, to have a system, where the books could be balanced from the private ledger alone, by having "sundry debtors" and "sundry creditors" accounts. The other books I suggest do not require much explanation. They are:—Register of letters inwards: giving columns for date received, from whom, on what subject, and date answered; to be posted into the instructions book as required. Postage book: columns for date, to whom, address, postage. Press-copy account book: no account to be sent out without being press-copied; entries to be made from this book to the commissions book, to be kept closely indexed. Press-copy letter book: every letter sent out to be press-copied; this book to be carefully indexed. Wages book: this book should have columns for date, name, amount of wages, the total to be drawn from the bank periodically. I have refrained from giving a set of *pro forma* accounts, as they are never very satisfactory, but have contented myself by showing the ruling of the various books and referring to the working in the letterpress, leaving you to fill in any imaginary figures you fell inclined to supply. I might have given a ruling for a bills-receivable and bills-payable

book. You will find them in every work on book-keeping. They are, however, little luxuries that should hardly come in the way of a professional man, and the more you in your profession as architects, and I in my profession as accountant, can steer clear of them, the better: they always have a peculiar knack of becoming due just when you are least prepared for them. If what I have written induces any of you to discard the bankers' pass-book and letter-book system and adopt something better, I do not think you will regret it, and I shall feel more than amply repaid for any time I have given in the preparation of this paper. Gentlemen, yours is an honourable profession, and so is mine. Our duties are towards our clients, and we must always endeavour to put them first, and ourselves second. And herein we both have the same difficulty to contend against. I refer to the sending in of accounts. You charge a commission on amounts expended, and so the more expended the larger the commission. In my profession we charge by time occupied; therefore the longer the time occupied, the larger our fee. But we are honourable members of honourable professions, and I feel sure that while I would not take longer over my work than necessary to do it well and thoroughly, so I am convinced that you would not cause your clients to spend their money in order to increase your commission. Until someone finds out a better way of arranging our charges, there is no help for it but for us to follow the old paths.

The PRESIDENT said he considered that well kept accounts were very necessary for architects in their business. The lecturer had put his subject in a very pleasant manner, but it was possible that the books suggested were more elaborate than would be required, and would entail the employment of at least another clerk. One of the difficulties the architect had to fear was that they would estimate the cost to clients of work but not to themselves. It was not easy to apprise the value of their own services and abilities except on the unsatisfactory system of percentage commission.

Mr. S. A. MIDDLETON proposed and Mr. G. H. GUILLAUME seconded a vote of thanks to the lecturer, the latter remarking that the system proposed was, he feared, too elaborate for the ordinary architect, who was satisfied with the entries in his diary, letter-book, and passbook.

Mr. SYLVANUS TREVAIL, of Truro, remarked that architects were not as a rule strict accountants, but such a system as had been suggested was suitable for men with gigantic practices, such as Mr. Waterhouse. Mr. Marshall had named a formidable list of books as necessary, and he should like to know if some of those could not be dispensed with. In a provincial business the accounts could be methodically kept in three or four small books. He must admit, however, that architects frequently lost small items, such as travelling expenses, and postage, and telegrams, through not booking them at the right time to the particular client. He thought the 5 per cent. commission plus actual out-of-pocket expenses fairly met most cases; but in some instances—as where an architect had to face an infuriated mob of a thousand to twelve hundred men who contested a right-of-way over the site—this might seem inadequate.

Mr. W. COOPER, of Hastings, also thought that, while the plan suggested might be the ideal one, it was too elaborate for any except large London practices.

The vote of thanks having been passed by acclamation, Mr. CALDER MARSHALL acknowledged it, remarking that if architects complained that correct book-keeping would compel them to employ an extra clerk, he should say, by all means employ the additional man.

SURVEYORS' INSTITUTION STUDENTS' PRELIMINARY EXAMINATION.

OF the candidates who presented themselves at the preliminary examination of this institution, held concurrently in London, Manchester,

and Dublin on the 19th and 20th ultimo, the following satisfied the examiners:—

Rowland William Alderson, Royal Agricultural College, Cirencester; Fred Tregarthen Allen, 6, Lawn Villas, Wisteria-road, Lewisham, S.E.; Charles Edward Amore, 53, Gresham-road, Brixton, S.W.; Algernon Lawrence Berry, 1, Spencer-road, South Croydon, Surrey; Ernest Witton Booth, The Grove, Ilkley, Yorkshire; Cecil Gustave Bradley, 103, Tettenhall-road, Wolverhampton; Thomas Brent, Fairlight, Shrewsbury-lane, Shooter's Hill, Kent; Hubert Brooker, Elinback, Steyning, Sussex; Eustace Montague Browne, Court House, Kingsthorpe, near Northampton; George Joseph Bruzard, The Vicarage, Addleston, Surrey; Alfred Eustace Buckley, South Field, Halifax, Yorkshire; William Burman, Kiveton Park, near Sheffield; Thomas Lingfield Caton, 82, Acre-lane, Brixton, S.W.; Charles Vyvyan Chilwell, 6, Weymouth-street, W.; Robert Cobb, Mockbeggar, Higham, Rochester; Arthur George Steuart Cooke, Ashbourne, Derbyshire; George Frederick Cotching, West Lodge, Horsham, Sussex; Adolph Henrich Dallschaft, 21, Drayton Park, Highbury, N.; Thomas Dann, Gwynant, Overcliffe, Gravesend, Kent; William John Dixon, Codicote Vicarage, Welwyn, Herts; Cyril Henry Donne, Leek Wootton, Warwick; John Wilfrid Earle, Allerton Tower, Wootton, Lancashire; Charles William Eastwood, 38, Yorkersgate, Malton, Yorks; Charles John Elgar, Crookshard, Wingham, Kent; Henry Etlinger, care of Mr. J. S. Kincaid, 7, Leinster-street, Dublin; Frederic Fletcher, Myddelton Lodge, Whetstone, N.; Walter Foster, Armaside, Hampton Hill, Middlesex; William Fox, 15, Holdenhurst-road, Bournemouth, Hants; Cecil George French, 6, Bedford-terrace, Bedford-road, East Finchley, N.; Kenneth Graeme Gairdner, 24, West-hill, Highgate, N.; Allen Gimson, 32, Fitzroy-square, W.; Edward Brougham Glazier, Edgecombe Hall, Wimbledon Park, S.W.; James Caulfield Goff, Agricultural College, Aspatia, Carlisle; Frederic Allen Sturge Goodbody, 35, Paradise-street, Birmingham; Alfred Goodman, 4, Clapton Common, N.E.; Ronald George Gurney, Brook-street, Aylesbury, Bucks; Clement Arthur Hall, 36, Gordon-place, Kensington, W.; Graham Harding, 66, Cannon-street, E.C.; Cecil Pryce Harrison, Caerhowel, Montgomeryshire; Ernest Harrison, "Westbrook," Bolton-le-Sands, near Carnforth, Lancashire; Sydney William Hider, 80, Upper Tollington Park, N.; Eric Cecil Hill-Whitson, 14, Agnew-street, Lytham, Lancs; Joseph Henry Hinchcliff, 13, Brudenell-avenue, Hyde Park, Leeds; Michael Anselm Hindmarsh, Cray View, Alawick, Northumberland; Robert Thomas Hodge, Kelvin, Cottenham-park, Wimbledon, Surrey; Charles James Hudson, Armlay House, Bridlington Quay, Yorkshire; Alfred Colin Hughes, 393, Moseley-road, Birmingham; Harry Hunt, 71, Parliament Hill, N.W.; Percival Hurlbutt, College of Agriculture, Downton, Wilts; Cecil Walter Ingram, 2, St. Andrew's-place, Lewes, Sussex; Frederic Johnson, London House, High-street, Erith, Kent; Arthur Bayly Jones, 6, Hatherley-road, Kew Gardens, Surrey; Herbert Davies Kelleway, 24, Bateman-street, Cambridge; Philip Reginald Kemp, care of G. E. Gregson, 11, Chapel-street, Preston, Lancs; Frederick Charles Knibb, 34, Honeywell-road, Wandsworth Common, S.W.; Harry Lisney, 11, Sydenham-road, Sydenham, S.E.; Charles Living, jun., 125, Broadway, Plaistow, E.; Philip John May, 25, Compton-avenue, Brighton, Sussex; Thomas James Mercer, 15, Warwick-row, Coventry, Warwickshire; Herbert Arthur Mitchell, 105, Western-road, Brighton, Sussex; Charles Evelyn John Monson, The Avenue, London-road, Newark-on-Trent; Charles Percy Moss, 58, Ashley-road, Crouch Hill, N.; Alfred Edward Oaten, Glenthorpe, Fairfield-road, Montpellier, Bristol; Hugh Earl Perks, 2, St. Paul's-square, Bedford; George Louis Pottier, 2, St. George's Villas, Whipp's Cross, Walthamstow, N.E.; Charles Edward Rawlins, 13, Grove Park, Liverpool; Harold Thomas Richardson, 52, Southbrook-road, Lee, S.E.; Henry Hubert Riddle, 139, Trinity-road, Tooting, S.W.; Gilbert Charles Rowe, Beechwood, Langley Park-road, Sutton; Wiloughby John Shaw, Yorkshire College, Leeds; Leighton Edward Shone, Woodhouses, Whitechurch, Salop; John Henry Simpson, Middleton Stoney, Bicester, Oxon; Walter John Slipper, 16, Duke's-street, Chelmsford, Essex; Cyril Herbert Smith, Buckhill, Calne, Wilts; Quentin Cullen Smith, 7, Grosvenor Gardens, Muswell Hill, N.; Harold Soper, 43, Buckingham-place, Brighton; Frank Ewart Spalding, 3, Lyndhurst-road, Hampstead, N.W.; Percy Abel Stanley, Newton-road, Burton-on-Trent, Staffordshire; Frank Edward Strudwick, 41, Park-road, Bromley, Kent; Gerald Drysdale Sweetman, Windsor House, 13, St. Thomas's-street, Ryde, Isle of Wight; Henry John Tilley, Barnhouse, Watlington, Oxon; John Reginald Tonson-Rye, Agricultural College, Aspatia, Carlisle; Ernest Davey Tredinnick, Penln House, Craven Arms, Shropshire; Jabez Tennyson Turner, 108, Greenwood-road, Dalston, N.E.; Robert Parsons Vale, Church House, Hartlebury, near Kidderminster; Clement Harwood Vince, The Tower House, Halton, near Lancaster; Gerald Douglas Wadham, Millwood, Dalton-in-Furness, Lancashire; Gilbert Russell Walker, The Chestnuts, Long Ashton, Somerset; Leon Maitland Walton, Ingleside, Manor Way, Bexley, Kent; William Henry James Weston, Gloucester House, Ashford, Middlesex; Francis West Wheeler, 159, Fulham-road, S.W.; Lancelot Elce Wilson, 47, Monks-road, Lincoln; Walter Alfred Wilshire, Fairfield, Reigate, Surrey; Leonard Wrang, Loxley, near Sheffield; Kenneth James Young, 167, Brixton-road, S.W. (\* Passed at head of List.)

FIREPROOF CONSTRUCTION OF DOMESTIC BUILDINGS.\*

(Concluded from page 122.)

UNDER the London Building Act concrete is sometimes filled in between the top and bottom flanges and metallic lathing fixed thereto and under the bottom flange; but it is seldom practical to employ concrete in this way

\* By THOMAS POTTER, of Alresford, Hants. A paper read at the Society of Arts on Wednesday evening, Jan. 26, 1898.

more than 3in. thick; it is difficult to apply in a soft state, and is, moreover, a moderately good conductor of heat, and, more important than all, the bottom flange of beam is either insufficiently protected or not protected at all. On the other hand, plastering mortar possesses little more than one-third the conductivity of brick or tile, and if applied so as to leave a hollow space behind, 1½ in. in thickness of plaster is more effective than 2½ in. of concrete. I am told that asbestos plaster has much less conductivity than common plaster. Captain Shaw, a former chief of the Metropolitan Fire Brigade, wrote some years since in reply to an inquiry on this point, "Very little plaster will suffice to prevent iron work from melting, softening, or cracking, if only it remains on, but this is the difficulty. Some key is absolutely necessary, and hoop iron or wire netting would probably be found the cheapest and best; with a really trustworthy key about half an inch of plaster would insure safety." When Captain Shaw wrote this, metallic lathing had not come into use. To ascertain for myself the capability of common plastering to resist fire, I built a small brick inclosure 7ft. square and 6ft. high, upon the top of which I laid steel joists and attached thereto a suspended ceiling on expanded metal lathing. When the plaster was thoroughly dry, I made a larger fire under than would be likely to occur in an ordinary room, and after two hours of fierce combustion and repeated quenching the upper side of the ceiling with buckets of water, the plastering remained sound, although pieces of wood an inch thick thrown on the top of the ceiling were ablaze in a few seconds from the heat conveyed through the plaster. I am bound to say the result was quite a surprise to me. The steel joists, although unprotected, were not injured to an extent that would cause them to buckle or expand to any degree, and nearly one hour after the fire was lighted were but moderately hot. A further protection may be practised by plastering the flanges and exposed portions of the beam with asbestos plaster, which adheres better to unpainted metal than to painted. I am unable to speak from experience as to the merits of asbestos; but if the reports concerning it are true, it has some marvellous properties in connection with fireproofing, as regards its resistance both to fire and water. Protected in this form, beams would withstand greater heat than if incased with concrete or terracotta or fireclay tiles, say 2in. thick, as the outer plaster incasement is everywhere disconnected from the beam itself, and forms a valuable and almost invulnerable first line of defence. Doubt has been expressed whether the heated air between the plastering and the beam would not expand and burst the incasement. This can be avoided by fixing an air-brick or tube in the walls upon which the beams rest; anyway, it should not be a difficult point to deal with. Joists in almost every system have their webs incased by the floor materials; the top flanges are much less liable to become overheated than any other portions, but the bottom flanges require greater protection than any other part, as they are at all times subject to a severe tensile strain, and in case of fire the heat is directed full against them. No floor is absolutely safe unless the bottom flanges are efficiently safeguarded. Sir Nathaniel Barnaby, in making experiments in connection with iron ships, found that iron and steel beams gained in strength up to between 490° and 550° Fahr.; beyond this their strength rapidly diminished. The moral to be derived is that if the steel beams and joists used in fireproof floors can be so far protected that they do not attain much over 500° of heat, they take no harm either from loss of strength, from heat, or expansion. Where beams have to be employed it is only reasonable they should be no longer than is absolutely necessary—i.e., they should be disconnected at every bearing where possible. Divided opinions prevail as to whether concrete is reliable as a fire-resisting material or the reverse; this depends mainly upon the materials of which the concrete is made. Thames ballast is one of the worst, and being used at one time for fireproof floors in London, many failures took place, and firemen were cautioned not to enter burning buildings which possessed fireproof floors. The most reliable fire-resisting materials are crushed bricks, coke, breeze, clinker from furnaces, slag from iron ore, pumice, and similar substances which have passed through fire. Mr. Webster's experiments proved that slag made the strongest concrete, broken firebrick came next, and then pumice, while coke breeze was the

weakest; but after being heated to a red heat, and quenched with water, the order of things was reversed, for it was found that slag had lost two-thirds of its strength, broken firebrick nearly as much, pumice about the same, but coke breeze less than one-half, and that the latter was then stronger than the other three materials. Neat cement was only about one-fifth its original strength after being heated and quenched; but it was clear that when diffused among other materials to form concrete, its strength from some cause or other was not diminished in the same ratio. But good concrete increases its strength with age, and assuming that a concrete floor will sustain the specified load required at a month, it should carry double that at a year, and from this we gather that if a concrete floor made of coke breeze is exposed to a fire, and becomes nearly red hot—say 1,000° Fahr.—it ought to be still capable when cold of supporting its original specified load, subject to not being weakened from other causes—and here another contingency arises: expansion from heat and subsequent contraction. This appears to be a substantial objection to the use of floors formed of a single slab without joists, or of large self-supporting areas of concrete for floors, whether flat or arched. So far as regards strength, first-class concrete requires no steel beams or joists whatever for floors up to 15ft. between supports, nor any iron imbedded therein. I have, many years since, executed 12ft. spans of a uniform thickness of 4½ in. only; but the effect of a fire would be to cause them to expand, and as they cooled to contract, and probably, through being tied into the walls and unable to adjust themselves to circumstances, break up into fragments. Concrete paths in public streets expand and contract with ordinary variation of temperature, and to avoid irregular cracks, are executed, as we know, in sections of about 9ft. square. But as the temperature in a house-fire scarcely exceeds, we are told, 1,000°, there should be no difficulty in so protecting the beams, the joists, and the concrete that neither should, in an ordinary house, be exposed to a temperature of more than 500° one hour or longer after a fire has got well alight. Cement concrete has some peculiar properties: for instance, it is not considered by any means an elastic material, but I have seen a slab 10ft. in length and 4½ in. in thickness deflect over an inch in the centre under a heavy load, and resume its original shape within a quarter of an inch, after having been weighted for several days. So that any perceptible movement or deflection of a concrete floor in walking over or jumping upon, does not necessarily imply danger. This is, however, not a pleasant sensation when the floor is known to be of concrete, and to avoid this a flat floor has to be thicker than is absolutely necessary for strength. A segmental arch-shaped floor has an advantage in this respect, for no matter how light it may be, it is practically rigid. A flat slab floor without joists has another disadvantage—viz., the effect of ordinary changes of temperature, as before described. The difference of temperature in the rooms of a dwelling is never very great, but combined with the tensile strain on the lower half of the floor, it is sufficient to cause slight cracks in the concrete on the under side, as the result of a change from heat to cold, and, although I have never known an accident result therefrom, cracks are naturally looked upon, and with good cause, as elements of danger. These cracks may not develop for a year or more after the floor has been completed, and if covered on the top with a wood casing, and the under side is plastered, they may never be visible. Then another objection to slab floors is that the lower half, or half below the neutral axis, is undergoing a tensile strain, a strain which concrete is least liable to resist, and these combined disadvantages go to prove that although flat floors of concrete without any joists are economical in cost and space, they are not adapted for rooms of domestic buildings. They may do very well for corridors, passages, lavatories, and the like, always remembering that concrete conveys sound more readily than any other building material; as an instance, conversation carried on in an ordinary tone in a room divided from another by a 6in. concrete partition, plastered on both sides, can be heard in the adjoining room; this I state from experience. Another type of floor is the same as the one just described, but has steel or iron rods, wire netting, expanding metal, or any other form of steel or iron imbedded in the concrete below the neutral axis, for the purpose of

counteracting the tensile strain. Floors of this character have been advocated for years, more especially those of Hyatt, Brammon, Monier, Edwards, the Expanded Metal Company, and several others. The main point is to prevent shearing of the imbedded material, and this is usually obtained by securing the ends of the metal ties in the concrete. The strength of concrete floors is largely increased this way; but the general disadvantages of the slab floor just described are still the same, and if large areas of concrete have to be divided into smaller by means of steel joists, I fail to see much advantage in the use of imbedded metal. The so-called solid concrete floor is more largely used than any other, principally because it costs less, can be executed by the builder, and came into use at a time previous to the general introduction of better systems. Joists are usually fixed 2ft. to 6ft. apart according to circumstances, and the concrete kept an inch below the bottom flange with the object of protecting the beam from fire, and a plaster ceiling is formed on the concrete. The objections to this form of floor, from my point of view, are—(1) that the one-half portion of concrete below the neutral axis is of little use so far as regards strength; (2) it conveys sound very distinctly; (3) the concrete having to be of a thickness equal to the depth of joist, plus the inch below, is very heavy; (4) the cost is thereby enhanced; (5) in case of fire, the under portion may become very hot before the heat reaches the upper portion; owing to the thickness it has to permeate, expansion in some places and none in others creates rupture of the particles, and, cohesion being weakened, masses may fall away, or if expansion occurred from heat, rupture of the concrete will take place at its weakest point, and that is where it incases the bottom flanges of the joists, which is only 1in. in thickness; should this happen, and the fire is extensive, the fate of the floor is settled, although in an ordinary way it should scarcely be sufficient for this; (6) plastering on concrete surfaces of this character to form ceilings has scarcely any key, the concrete surface being simply jagged or indented with a pointed tool, and in case of fire the plastering will possibly soon fall away—indeed, it often occurs without a fire. The weight of a concrete floor of this kind, as shown, 9in. in thickness, is about 40lb. to 50lb. per superficial foot, without the joists, whilst the greatest live load necessary to be provided for floors of domestic buildings is said to be only between 20lb. and 30lb. at most. A modification of this floor so as to reduce the weight of concrete was adopted some years ago, but can scarcely be called a fireproof floor; a better title would be an improved wood floor. These are a description of floors usually performed by any kind of labourers. My experience is that workmen who have acquired an intimate knowledge of concrete floors, and take an interest in their work, perform it in a superior way, produce better work, and are more reliable. Concrete floors which have collapsed have been done by men of no experience. There is an impression that concrete floors of an arch form exercise considerable thrust, and must necessarily be held together by tie-rods and bolts, but, except in large spans, this is not so. Indeed, arch-shaped concrete assumes more the character of a cantilever than an arch. But level ceilings are necessary for rooms of dwelling-houses. This can be obtained by forming them of metallic lathing suspended to the joists, while the vacant space that intervenes creates a barrier to the transmission of sound. Fawcett's floor and Homan's floors are too well known to require any description; they are types of the lintel form of construction, with a portion going under to protect the bottom flanges. Concrete is filled in up to the level of top of joists, and the under sides of the lintels are plastered in the usual way. There are numerous floors of the lintel type—Willis and Astley's, Pickering's, Fergusson's, and others. I offer no opinion as to the relative merits of any patent floors in use. Were I to do so impartially, I could only say that probably they will all safely support any reasonable load; that their cost is very much the same; that each may possibly possess some advantage, more or less, over others; but until a series of tests have been made as to fire-resisting and other desirable properties of some of the best types of floors by independent authority under similar conditions, and upon areas of suitable dimensions, no comparative results are possible. The patentee of every floor can bring ample evidence, without a doubt, to prove that

his system is far better than any other, and also that the severe trial it has withstood against fire in a small test-place 7ft. or 8ft. square, arranged for the purpose, has beaten all previous records; all the same, it is quite a different thing to a fire in an apartment 18ft. or 20ft. each way, and not specially constructed to be tested. My views as to fireproof floors for domestic buildings are:—

(1) Steel beams should be avoided as far as possible; up to 24ft. span, or between bearings, they can be dispensed with altogether, and joists of moderate size substituted at but little increase of cost. (2) Where, however, steel beams are necessary, the greatest care should be given to protect them from fire. (3) Steel joists to divide floors, whether flat or arched, should not be more than 6ft. apart, and should also be well protected, more especially the bottom flanges, which, as a rule, are less cared for than other portions; the top flanges are not so important. (4) A better quality of concrete, and less of it than is usual, should be employed to lessen the enormous weight thrown upon walls and foundations. (5) The plastered ceilings should, if possible, be of a character that will not fall or come away as the immediate result of a fire beneath. The properties aimed at in fire-resisting floors of domestic buildings should be as follows: (1) Resistance to fire, (2) non-conductivity of sound, (3) lightness compatible with safety, (4) economy of space, and (5) economy of cost. I have endeavoured to carry out these principles in a floor shown; but although highly successful on a small scale, like everyone else's patents, I am unfortunately unable to say what the result would be in a genuine big fire. The bottom flanges are incased with burnt-clay shields, an air-space intervening, and a metallic lath-suspender ceiling is fixed to the shields by iron hangers and lathing bars; permanent iron centres are used for forming the floor, and the bottom flanges of joists have a double air-space protection. The best covering for a concrete floor is wood in narrow widths, nailed direct on the concrete itself. Obviously the floor must be first made quite straight, and the materials of a consistency that will enable nails driven therein to hold equally as well as if driven into wood. It has been said that the wood will rot; but I have done floors in this way for 16 years and found no decay yet, and for some reasons they are preferable to wood block floors and cost less. Dovetailed strips of wood imbedded in concrete for nailing boards thereto I found acquire dry rot and decay more or less in from three to four years. Wood laid on concrete direct will not burn except through the strongest provocation; it will smoulder and become charred. Small wood joists laid on the concrete and floor-boards fixed thereto in the usual way will burn rapidly. It is worthy of being more generally known that cement used for making concrete parts with as much water as is unnecessary for hydration, and clear water can always be seen dripping from concrete newly laid on temporary centring or wood platform formed to uphold it. This is often supposed to be a case of too much water having been used in mixing; but it is not so, unless it is coloured with cement, in which case it is evidence of the latter having been carried through the concrete owing to the use of an excess of water, and the floor is obviously weakened therefrom. As a matter of fact, concrete for any purpose is assumed to be such a commonplace thing that it is difficult to evoke any interest in connection therewith, so far as building matters are concerned. But the large fires which have taken place will, it is hoped, be the means of inducing the London County Council or the Government, or some other independent authority, to make a series of independent tests of various kinds of fireproof floors, partitions, beam incasements, &c., that architects and the public in general may be put in possession of some reliable data relative to so-called fireproof buildings, and if a building was set apart for specimens and exhibits of fireproof floors, partitions, cements, and inventions, and products relating to fireproofing, architects and others would be able to see and judge for themselves as to what would be likely to fulfil their requirements instead of having to rely entirely upon pamphlets, advertisements, or circulars.

TILE AND CONCRETE FLOOR TESTS.

WE are not great believers in public tests of materials, but our American cousins seem to place great faith in them. If the conditions are fair, and the experiments are conducted in a natural manner under guaranteed supervision, these trials would be of value; but for some reason or other these conditions do not often prevail. There have been several tests lately in New York city, under the auspices of the New York Building Department, on concrete and tile arches and floors. We lately recorded those conducted by that department, in which the Roebling arch was tested with others. A large firm of manufacturers (Messrs. Maurer and Sons) in New York lately challenged other firms of manufacturers of fireproofing materials to take part in a 24 hour test, and the Roeblings, at the instance of a superintendent of the Building Department, accepted the challenge with certain provisos—one that the conditions should be the same as those before accepted; but Messrs. Maurer declined those modified terms, and issued an injunction restraining the superintendent from taking part in the test. Several engineers and architects, on behalf of Messrs. Roebling, made the test, however, which resulted, after firing for three hours, in a deflection of 1.4in. for the Roebling arch, and of 3.65in. for the tile arch. The latter gave way between two tie-rods, and an area of 5ft. by 5ft. fell with its load, whereas the Roebling arch is declared to have remained intact, with shreds of the skim coat hanging to the ceiling. The temperature reached 2,000° uniformly applied. The tile construction, however, has established its value as a fireproof construction, from what we hear.

CONSTRUCTION OF ARCHES IN CONCRETE.—XVI.

(Concluded.)

IT only remains for us to sum up in a terse and compact form, the salient results of the experiments, tests, and observations which have been described and illustrated in our preceding articles. In instituting comparisons, discussing merits, and drawing our conclusions with respect to the behaviour of the five large arches of 76ft. in span, we shall not include the last, that is the fifth, on the list of examples, which is wholly constructed of wrought-iron. Our reason is that it is impossible to institute any real or fair comparison between a purely metallic arch and any one of the four other structures submitted to the same trial. The practical conditions between an iron flanged rib and a solid concrete one, or one of concrete strengthened by iron or steel, or between the wholly metal type and arches of brick and stone, are too diverse and wide apart to admit of any useful investigation or discussion with a view to establishing even an approximate similarity of features and properties. In all the four arches there was particular attention bestowed upon two especial cases of loading. One was when the "critical load," as it was termed, was imposed, and the other when the actual breaking load came into active operation. The critical charge was also the load, the application of which gave rise to the incipient cracks and "threads," which subsequently augmented in both size and number, although in indirect proportion, with corresponding additions to successive loads. As has been stated, both the critical and breaking loads varied for each different arch; but it may be remarked that the ratio between these two loads for each individual arch obeyed no law. Table I. has been calculated so as to exhibit the amount of the two loads and the ratio between them. Under column 1 are the loads which produced deformation of the longitudinal axis in the different arches; in columns 2 and 3 are recorded the critical and breaking loads, and the difference between these last two are given in the fourth column. The values are all in tons, with the exception of those in column 4, which are percentages. An inspection of Table I. points out that arches of stone and brick do not vary much in the amount of their ultimate powers of resistance; but so far as the critical load is regarded, the latter is considerably weaker than the former. The concrete arch shows increased strength under both loads, but the three are far surpassed by the Monier cement-and-steel type. It is important to notice here the different causes which led not only to the primary deformation of the longitudinal axis of the arches, but also to the formation of the cracks and fissures. In the structures of stone and brickwork these defects,

which manifested themselves after the loads in column 3 of Table I. were superimposed, were due solely to the want of a proper grip of the mortar upon the masonry and bricks at the joints. But in the case of both the simple and compound concrete or cement arches, the cracks were the

TABLE I.

Description of Arch.	1	2	3	4
Stone .....	35.123	57.014	73.489	30
Brick .....	34.927	41.798	68.123	58
Concrete .....	57.147	62.314	83.342	32
Cement and Steel..	58.711	79.614	145.959	57

result of the action of stresses of a tensile character, and were not developed in the Monier cement-and-steel example until the critical load assumed proportions a good deal in excess of what was sufficient to render them distinctly visible on both faces of the other two experimental specimens. If, therefore, the adherence or grip of the mortar in the stone and brick bridges had been equal to the resistance of the materials of the other two arches against the tensile stresses to which they were exposed, the difference between their respective ultimate breaking weights and critical loads would not have been by any means so great. In order to arrive at a satisfactory conclusion on this point, a series of experiments were instituted to accurately determine what the adherence of the mortar was, and what was the actual resistance of the concrete and cement-and-steel bridges. Let A = the average strength or adherence of the mortar, M the maximum, and m the minimum, values; then—

$$A = \frac{M + m}{2}$$

But adopting the square inch as the unit, the actual tests proved that the values of M and m were respectively in pounds—

$$M = 124. \quad m = 83;$$

from which we find for A that it becomes—

$$A = \frac{124 + 83}{2} = 103.5 \text{ lb. per square inch.}$$

Comparing this with the resistance of the simple concrete arch to the stresses of tension, we find that the value of A in the latter case rose to—

$$A = 233.78 \text{ lb. per square inch.}$$

It is when we take into consideration the result obtained in the Monier arch, built on the combined or compound principle of cement-and-steel, that the advantage of the combination becomes apparent beyond any reasonable doubt. Solving for A we have—

$$A = \frac{830.24 + 555.37}{2},$$

and finally—

$$A = 717.855 \text{ lb. per square inch.}$$

These different values of A in the arches may be compared thus:—Put A<sub>1</sub> for the value obtained for A in the brick and stone arches, A<sub>2</sub> for that in the plain concrete arch, and A<sub>3</sub> for the same in the compound Monier arch; their respective relations will be given by the following equations:—

$$A_3 = 3.07; \quad A_2 = 6.93; \quad A_1 \text{ and } A_3 = 2.25 A_1.$$

The manner in which, and the points along the elevation of the arches at which, the fissures appeared; their disappearance or closing up after the partial removal of the load, and their subsequent reappearance upon the reimposition of it, and other details, have been fully described in previous articles; so we shall not further recapitulate. By observing the deflections and also the vertical deformations of the arches at the various points where the loads were placed, it was not a very difficult matter to compute the coefficients of elasticity for each; but as the calculations are complex and tedious, we shall give the results only. Thus, for stone, the value of the coefficient was 830,500lb. per square inch, for brick 382,250, for simple concrete 3,382,500, and for the steel-and-cement construction 4,585,625, all in the same units. The importance of the coefficients of elasticity of the different materials in the structures under consideration is evident from the fact that the stiffness or resistance to deformation and distortion is proportional to the amount of these coefficients. It should be borne in mind that in order to render a road or railway bridge unfit for its duty it is not necessary to actually break it down. After it has suffered a certain amount of deflection and deformation, it is placed practically *hors de combat*.

The Salford Board of Guardians decided on Friday to purchase twenty acres of land on the Weaste estate, near the Union Infirmary, for £14,000 as a site for the proposed new workhouse.

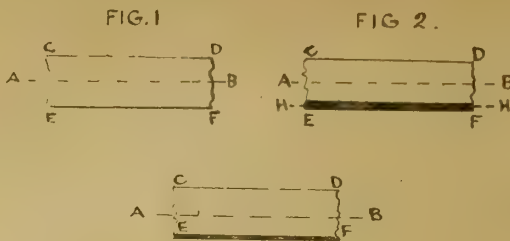

FIG. 3.

The proof of the statement that the stresses in the two materials—namely, the concrete and the steel—in the compound system of construction are dependent also, as well as the rigidity of the arch, upon their module of elasticity, may be thus expressed mathematically. Let  $S$  equal the tensile stress in the concrete at or near the region, where the rod, beam, or other section of steel is imbedded, and put  $S_1$  to represent the stress of the same character in the steel or other metal as the case may be. Put  $M$  for the modulus of elasticity of the metallic material, and  $M_1$  for that of the concrete; then the tensile stress on the steel will be given by the equation—

$$S_1 = \frac{M \times S}{M_1}$$

The symbol  $S_1$  will give the value of the tensile stress in pounds per square inch. In thus deducing the stress upon the metallic part of the arch—or, as in the present case, the steel—it is assumed that it and the other material, the concrete, both stretch to the same extent. This assumption is theoretically not quite correct, but sufficiently so for all practical purposes.

The influence which the addition of steel bars or plates have upon the depth of the girder must be taken into account, and the extent to which they will modify that most important dimension in all bridge structures will depend upon their position. Three examples here present themselves which are shown in Figs. 1, 2, and 3. Let Fig. 1 be a short length of a portion of a simple concrete arch, and, for the sake of simplicity, supposed to be straight; then its neutral axis will be represented by the line  $A B$ . Put  $d$  for the total depth of the concrete rib; then its position will be at a distance from either the top or bottom

of the arched rib equal to  $\frac{d}{2}$ —that is, at the centre of the rib. In the second case, let a plate shown by the dark line in Fig. 2 be bedded in the concrete, and make  $d$ , as before, equal to the total depth of the compound rib, and put  $d_1$  to equal the depth of the concrete part: then it can be proved that the distance of the line  $A B$  from the line  $H H$  is always equal to  $\frac{d}{2}$ , when the line  $H H$  is placed at the centre of the imbedded steel plate or bar. Make  $t$  equal to the thickness of the metal, and put  $d_2$  equal to the vertical distance between the two parallel lines  $A B$  and  $H H$ . The statement to be proved is that—

$$d_2 = \frac{d}{2} \dots \dots \dots (1)$$

But we have also—

$$d_2 = \left\{ \frac{d_1}{2} + \frac{t}{2} \right\} \dots \dots \dots (2)$$

Consequently, from equation (1)—

$$\left\{ \frac{d_1}{2} + \frac{t}{2} \right\} = \frac{d}{2} \dots \dots \dots (3)$$

from which, by reducing, we obtain—

$$d_1 + t = d \dots \dots \dots (4)$$

But from the nature of the question—

$$d_1 = (d - t) \dots \dots \dots (5)$$

so that we finally find—

$$(d - t) + t = d \dots \dots \dots (6)$$

from which the identity of the two sides of the equation or  $d = d$  becomes apparent. As a practical example, let  $d = 12$  in. and  $t = 1\frac{1}{2}$  in. The value of  $d_2$  should be equal to  $\frac{d}{2} = 6$  inches.

From equation (2) and (4), substituting the numerical values of  $d_1$  and  $t$ , the equation becomes—

$$d_2 = \left\{ \frac{10.5 + 1.5}{2} \right\} = \frac{12}{2} = 6 \text{ in.}$$

If the same method of calculation be pursued in the case represented in Fig. 3, in which the steel plate, shown by the black line, is fixed outside the lower part of the concrete portion of the

rib, it will be always found that the expression for the value of  $D_2$  will be—

$$D_2 > \frac{D}{2}$$

A comparison of the breaking weights, which, it will be remembered, were distributed over one-half of the span, or over the half-arch, gave the result set forth in Table II. The breaking weights were the weights reduced to the unit of area—that is, the weight in pounds per square foot. In the table, the breaking weight of the brick arch, which was the weakest of the whole five, is taken equal to unity. The

TABLE II.

Description of Arch.	Breaking Weight.	Cause of Failure.
Brickwork ..	1.0000	Cracks in the joints
Stonework ..	1.0963	Cracks in the joints
Concrete .....	1.2359	Cracks at dangerous sections
Concrete and steel .....	2.1594	Cracks on loaded and unloaded half-span
Iron .....	2.7641	Buckling of plates at haunching

superior strength of the compound system is again manifest as compared with the other three types of the simple principle. Although the arch is included in this table, the remarks previously applied to it hold good.\* It may be stated that, generally speaking, all the arches failed at or near the points dictated by theory. Obviously in building bridges belonging to any one of the four classes specified, the structure must have a minimum width at the crown which must be maintained constant to each springing, though it is preferable, especially when the span is comparatively large, to increase this dimension towards the points of supports. The percentage of increase may vary between 0.05 and 0.075 of the central width. We have given in Table III. a list of the minimum widths which experiments have demonstrated to be most suitable for the spans correspondingly annexed. It will be observed that the ratio of the depth to the width follows very nearly a constant proportion, the average proportion being  $\frac{1}{3}$ . We may deduce, therefore, as a general rule, that the minimum width for bridges of the classes under notice should not be less than  $\frac{1}{3}$  of the span. In spite of the marked superiority of the compound system of constructing arches in concrete, as

TABLE III.

Span in feet.	Width in feet.	Ratio between depth and width.
100	7.92	$\frac{1}{12}$
130	9.94	$\frac{1}{13}$
220	14.35	$\frac{1}{11}$
330	22.16	$\frac{1}{15}$
400	28.38	$\frac{1}{14}$

shown by the actual practical tests carried out, the engineers in charge of the experiments did not report in favour of it. They appear not to have been quite satisfied exactly how the separate materials in the compound type performed the respectively different duties assigned them; and this is a weak point, as must be admitted, in all combinations of a similar nature. Briefly, the conclusions arrived at were: (1) that for arches under 130ft. in span rough stonework would answer well, and (2) that for arches of spans above that dimension, either ashlar masonry or concrete might be advantageously employed. Be that as it may, we have placed before our readers all the information there is on the subject, and they are perfectly competent to judge for themselves.

T. C.

\* Apropos to our subject, though not exactly in a constructive sense, few people are probably aware that the compound principle has been adopted by dentists in the manufacture of artificial teeth, but so it is. A very finely close-meshed network of aluminium is interwoven with the vulcanite "plate" at its surface, very much after the pattern of the "expanded metal" process. The application is decidedly ingenious and a little curious as well.

WARDLEY HALL, LANCASHIRE.

[WITH PHOTOLITHOGRAPHIC ILLUSTRATIONS.]

THIS most interesting old Hall, which has recently been very carefully restored, was originally part of the inheritance of the Worsleys of Worsley. The Wardley estate passed to Thurstan Tildesley (a member of the family who were Lords of Tyldesley) by marriage with Margaret, daughter and heiress of Jordan Worsley, in the beginning of the 15th century, from the Tildesleys to the Sheringtons, from them to the Downes, who were probably a branch of the Cheshire family of that name, and who seem to have acquired the Wardley estates by purchase. Roger, the first of the Wardley Downes, died about 1538, and was succeeded by his son John, who married a daughter of Sir Cecil de Trafford, from whom he probably obtained the Barton portion of the property. By her he had two children, Roger and Penelope. Roger died without issue in the year 1675, leaving his sister sole heiress to his property. Miss Downes married Richard, third Earl Rivers, of Rock Savage, Cheshire. Their only daughter and heiress, Elizabeth, married the Earl of Barrymore. Lady Barrymore's only child and heiress, Penelope, married the Hon. James Cholmondeley, second son of the Earl of Cholmondeley. By arrangement with her husband (from whom she was divorced *à mensa et thoro*) she obtained power to dispose of the Lancashire estates, which belonged to her maternal grandfather, Earl Rivers. She sold the estates in 1760 to Francis, third and last Duke of Bridgewater, to the trustees of whose will they now belong. A peculiar interest has long been attached to the house on account of a human skull being kept there, as regards which there are several traditions. It seems, however, that the true story is shortly as follows. The skull is that of a Benedictine monk, Dom Edward Ambrose Barlow, called Father Ambrose, fourth son of Sir Alexander Barlow, Kt., of Barlow Hall, near Manchester. He was born there in 1585. In or about 1617 he was sent from the English monastery at Douay to labour in his native country. He devoted his services almost exclusively to the southern parts of Lancashire, ministering chiefly in the secret chapels at the halls at Wardley, Worsley, and Morleys, the latter being the seat of the Tyldesleys. On Easter Sunday, April 25, 1641, he was preaching to his congregation in the domestic chapel at Morleys Hall, when the house was besieged by "a neighbouring minister" at the head of a fanatical mob. The priest was arrested and carried before a neighbouring Justice of the Peace named Risley; by him he was sent under an escort of 60 armed men to Lancaster, and at the next assizes was tried and condemned to death. On September 10 the martyr was drawn on a hurdle to the place of execution at Lancaster, and there hanged, cut down, butchered, and his quarters parboiled in the tar cauldron, as customary in such cases, in the fifty-fifth year of his age, and the twenty-fourth of his priesthood. His head, having been impaled either on the castle at Lancaster, or on the old church in Manchester, as was frequently done, was secretly secured by Mr. Francis Downes, and reverently preserved in his mansion at Wardley. There it remains to this day, an object of wonder, and a speaking illustration of times now happily changed. It is about twenty years since Wardley Hall was last occupied, excepting only the portion now used as stables, which had been made into three cottages, and they were usually occupied by colliers, who worked at the great Bridgewater Colliery close by. During that period it has only been so far repaired from time to time as to be kept weather-proof, and it has suffered some damage on account of the coal-workings beneath it. In 1894 it was decided to restore the house, with a view to it being used by one of the principal officials of the Bridgewater trustees, and, thanks to the interest taken in the matter by the Earl of Ellesmere, the proprietor of Worsley, no pains have been spared to carry out the restoration in as perfect a manner as possible. Messrs. Douglas and Fordham, architects, of Chester, were engaged to design the details of the work, and though it was necessary to rebuild some portion entirely, there is no appearance of newness about the place anywhere, and the architects deserve much credit for the skilful and artistic manner in which they have dealt with a difficult problem. The work itself was done by the Bridgewater Trustees' own workmen, under the direction of their engineer,



Chamber Floor Plan

WARDLEY HALL, LANCASHIRE.

Mr. Frederick E. Cairns, who is now the occupant of the house. It proved to be quite impossible to discover what had been precisely the original form and arrangements of the house, but one thing is quite certain—viz., that the suppositions in this respect of those persons, who before the restoration ventured their opinions, and in some cases published them, are all, more or less, erroneous. When the work was commenced the only two living rooms were those which are now designated the drawing-room and dining-room. The principal entrance, such as it was—in fact, the only entrance to the main part of the house—was the main staircase and the kitchen. The present lower hall was a washhouse, the smoking-room a place for firewood and sundry rubbish, and its upper part a dovecote; the cloak-room was a coal-hole. There was no kitchen entrance or back stairs. On the upper floor there was no semblance of the large upper hall, the space being occupied with several very dark and ill-arranged rooms. The house has suffered severely from the ex-cruciatingly bad taste and Vandalism of a period now fortunately past, and has been mutilated in the most wanton manner. When the work of restoration was commenced, it soon became apparent that there was much more interest in the house than was at first supposed. In all cases where there were beautifully panelled ceilings formed of massive and richly-moulded oak beams, the most prominent members of the mouldings had been roughly chopped off—apparently with an adze, and on to them, or below them, had been nailed laths, and the whole were hidden by plastered ceilings. Where the larger beams projected, all of them being oak, they had been hacked over and covered with plaster, their sections being converted into plain rectangles with chamfered edges; and, to add insult to

injury, these improved (!) beams had been painted and grained in imitation of oak. The fine old staircase had been similarly treated, and so numerous were the coats of yellow paint that it took many days of arduous labour to remove it. When it was discovered that the ceiling of the upper hall extended so far as it does, it was decided not to divide the space, as was at first intended, but to leave the whole open, as it evidently had been originally. The fireplaces here and in the hall below were discoveries, being quite invisible when the work commenced. The wide stone arches had been built up, and ordinary cast-iron "register" grates inserted. In the upper hall the old arch is reinstated after having been repaired, the same stones being used; but in the lower hall the stones had been so much damaged that a new arch was necessary. In the dining-room, too, there is an old stone arch; but it is entirely past restoration. In the room over the pantry there was found some old oak panelling lathed and plastered over, and above this, above the ceiling, some ornamental plaster-work. This panelling has been repaired and placed at the end of the upper hall, and it is proposed to attempt to restore the plaster-work and place it again above the panelling. A good deal had to be done in order to make the house dry and healthy. Water was lying a few inches below the floor level, and consequently the whole site had to be carefully drained, the walls under-pinned, and a damp course inserted, and a bed of concrete was laid under all the floors. In the lower hall and entrance lobby the floor is laid with oak blocks, mostly made of bits of old timber, which had to be replaced in the course of the work. The roof was found to be remarkably sound, scarcely needing any repair. Visitors to Wardley will probably miss some of the black

and white work with which they were so familiar; but as all that on the north front was sham, being painted plaster, and not timber work at all, it was thought best not to replace it, but to restore the old brick walls which it covered. New windows were required throughout the whole house, those in the brick walls being made of red Runcorn stone, and those in the half-timbered portion, of oak, and the whole are fitted with wrought-iron casements made by Messrs. Wragge, of Manchester, the lead work being simple and very pretty. The firegrates are, with very few exceptions, of the front hob or economiser patterns. The restoration, though a costly matter, has resulted in the saving from ruin of one of the most interesting old houses in Lancashire, and, moreover, in making it as quaint and comfortable a home as could be wished for. The skull, which during the progress of the work was placed in an iron safe, is now reinstated in a niche in the wall of the staircase, where for many years past it has lain carefully protected with glazed doors.

Plans are being prepared by Messrs. Austin and Paley, of Lancaster, for a new church in the parish of St. Anne, Hindsford, near Atherton, and the ceremony of laying the foundation-stone will shortly take place. The estimated cost of the building is about £6,000, and there is in hand over £3,700.

Through the munificence of Mr. Thomas Sutton Timmis, of Allerton, Liverpool, the tower and nave of Acton Church, Nantwich, has just been completely restored. Mr. Timmis's mother many years ago resided at Acton, and the work of restoration was undertaken by Mr. Timmis in commemoration of her memory at a cost of nearly £5,000. The chancel of the church is being restored by Lord Tollemache, and Mr. H. J. Tollemache, M.P., has undertaken to erect an organ loft at a cost of £600.

## OBITUARY.

Mr. WILLIAM C. T. DOBSON, an honorary retired Academician, of Petworth, died at Ventnor on Saturday in his 81st year. He was born in 1817 at Hamburg, where his father was an English merchant. He began to study from the antique at the British Museum when 14 years old, and became a student of the Academy at the age of 19. In 1843 he was appointed head master of the Government School of Design at Birmingham, but relinquishing that post two years later, he travelled in Italy and Germany. Mr. Dobson was elected an Associate of the Royal Academy in 1860, and an Academician in 1872, when he painted "St. Paul at Philippi" as his diploma picture. In 1875 he was elected a member of the Royal Society of Painters in Water-Colours. Among Mr. Dobson's principal pictures are "The Alms Deeds of Dorcas," painted in 1855 by command of the Queen; the "Child Jesus going to Nazareth," 1857, which, with another early work, is in the possession of the Baroness Burdett-Coutts. These were followed by a number of groups of children, of religious pictures, and other *genre* works, some of which were executed in oils and others in water-colours. Many of his works, which were delicate in execution and sentimental in character, have been engraved. His last exhibited works were portraits shown at Burlington House in 1894.

By the death of Mr. JAMES O'BYRNE, architect, Liverpool, the Roman Catholic Church of the Liverpool diocese has benefited to a considerable extent. The testator's unique collection of books, coins, arms, pictures, mezzotints, engravings, photographs, curiosities, and art furniture is bequeathed to the Roman Catholic Bishop of the Diocese of Liverpool (Dr. Whiteside), so that it may form a nucleus for a museum at the Roman Catholic seminary of St. Joseph, at Walthew Park, near Upholland, in the county of Lancaster. The total value of the collection is said to be about £20,000. The residue of his estate Mr. O'Byrne has left to Bishop Whiteside absolutely. The personal estate, inclusive of the historical collection, is expected to amount to something like £105,000; and the residue, with the freehold property will, it is believed, be between £40,000 and £50,000. Although the last-named amount is left to the Roman Catholic bishop absolutely, it is understood that it will be devoted to the advancement of the church of which he is the head in the diocese.

## CHIPS.

The bells in the parish church of Chediston, Suffolk, have been reframed, refitted, and rehung, and another has been added to the peal. The work has been done by Messrs. Day and Son, of Eye. The Bishop of Norwich dedicated the peal on Wednesday in last week.

At the annual meeting of the Royal Cambrian Academy of Arts, on Saturday, a letter was read from Sir. E. J. Poynter, P.R.A., consenting to become a hon. member of the Cambrian Academy. It was resolved to throw the Cambrian Exhibition this summer open to all artists in the United Kingdom. Mr. C. Boydell and Mr. H. Hughes were elected full members, and Mr. E. Bottomley, Mr. T. Clough, Mr. R. E. Morrison, Mr. G. H. Swinstead, and Mr. Brint Turner were elected associates.

Colonel A. G. Durnford, R.E., an inspector from the Local Government Board, held an inquiry at the Reading-room, B shopstoke, on Friday, with reference to the application by the Winchester Rural District Council to borrow £5,000 for the purpose of carrying out a system of drainage for Bishopstoke, from plans by Mr. Berrington.

The annual dinner of the Leeds Builders' Exchange Club was held on Friday evening in the Grand Restaurant, Leeds. Mr. W. Lolley presided, and over 100 sat down. After dinner a short toast-list and musical programme was gone through.

The corporation of Southampton have raised the salary of Mr. W. Matthews, who has been the waterworks engineer since 1884, from £410 to £450 per annum.

At the Manchester Consistory Court on Friday, a faculty was granted for rebuilding St. Peter's Church, Oldham, and also to the vicar of Holy Trinity, Coldhurst, Oldham, to remove all plain glass windows and replace them with stained glass, six being memorial windows, to replace the present font with one of alabaster, to take down the gallery at the west end, to convert the north and south doors into windows, to open a new doorway at the west end, to build a porch at the west end, and to place a brass tablet in the chancel.

## ARCHITECTURAL &amp; ARCHÆOLOGICAL SOCIETIES.

BRISTOL MASTER BUILDERS' ASSOCIATION.—The annual meeting of this association was held on Monday at the Guildhall, under the presidency of Mr. August Krauss. There were also present Messrs. G. Humphreys (treasurer), F. N. Cowlin, J. E. Jones, G. Downs, E. F. Woodward, J. James, E. Walters, C. Cowlin, C. A. Hayes, W. Podger, A. S. Scull, and H. J. Spear (secretary). The president moved the adoption of the report and accounts, and said that they were pleased to know the building trade was good in Bristol last year, and, what was still better, they had no disputes with their men. They had formed that year their West of England and South Wales Federation, which consisted of builders in Bath, Bridgwater, Cardiff, Newport, Taunton, Plymouth, and Weston-super-Mare. The federation had been formed for the purpose of doing justice to their men and themselves. The federation had taken steps as regards the Employers' Liability Act, and approached the architects to have a clause inserted in quantities similar to a fire insurance clause, so as to relieve the builders of heavy responsibility, and other federations had also taken that step, which would certainly be favourably considered by the architects. The Bristol Channel Timber Importers' Association had reduced their terms for credit, and the builders were fully justified in asking that the percentage of retention money should be reduced on contracts. Mr. Downs seconded the resolution, and dwelt upon the importance of enrolling new members. He was pleased to observe from the treasurer's account that the membership had been augmented considerably during the past year. The resolution having been adopted, the president announced their vice-president, Mr. William Church, was unable to accept the office of president in consequence of indisposition. Mr. G. Wilkins moved a resolution expressing their appreciation of the long and valued services of Mr. Church. Mr. C. A. Hayes seconded the resolution, which was carried by acclamation. Mr. Walters proposed, Mr. J. E. Jones seconded, and it was carried by acclamation, that Mr. August Krauss be re-elected president for the ensuing year. Mr. F. N. Cowlin was elected as vice-president, and Mr. A. S. Scull moved, and Mr. Podger seconded, that Mr. George Humphreys be re-elected treasurer for the current year. Messrs. Hayes, Downs, Wilkins, Scull, and Eastabrook were added to the committee. The annual dinner of Association was afterwards held at the Royal Hotel, under the presidency of Mr. A. Krauss.

GLASGOW ARCHITECTURAL ASSOCIATION.—At the usual monthly meeting—the president, Mr. W. T. Conner, in the chair—Mr. Wm. Brooks Sayers, member of the Institute of Electrical Engineers, delivered a lecture entitled "Electric Light, Heat, and Power—their efficient Installation and Cost." The lecturer opened his subject by drawing a picture of what electricity could do to lighten the burden of existence. With electric light, heat, and power, we would have no smoke, filth, or suffocating fogs, thus leaving everything fresh and clean without and within; we could pave our streets with asphalt, over which the rubber-tired motor vehicles would skim noiselessly. A descent, however, to the practical showed that much progress had yet to be made, which Mr. Sayers demonstrated by tables and figures, comparing the cost of electricity, gas, and water, supplemented by a description of the different systems and apparatus for electric lighting, illustrated by examples. At the close, a hearty vote of thanks was accorded the lecturer.

LEEDS AND YORKSHIRE ARCHITECTURAL SOCIETY.—A dinner in commemoration of the 21st anniversary of the founding of this Society was held at the Queen's Hotel, Leeds, on Monday evening. Mr. George Carson, president, was in the chair, and amongst those present were the Lord Mayor of Leeds (Alderman Tetley), Mr. W. S. Braithwaite (vice-president), Mr. W. M. Fawcett (vice-president of the Royal Institute of British Architects), Mr. W. B. Woodhead (president of the Bradford Society of Architects), Mr. E. Matheson (president of the Leeds Chamber of Commerce), Mr. A. T. Walker (president of the Association of Yorkshire Students, Institution of Civil Engineers), Dr. Bodington (Principal of the Yorkshire College), Alderman Gordon, Mr. T. Riach, Mr. H. J. Palmer, the Rev. Canon Wood, Mr. John Ely (president of the Manchester Society of Architects), Mr. G. Benson (president of the

York Architectural Society), Dr. Scattergood (Dean of the Medical Department of the Yorkshire College), Mr. E. W. Batley (chairman of the Building Clauses Committee of the Leeds Corporation), Mr. H. Perkin, Mr. G. Atkinson, Mr. H. S. Chorley, Mr. J. N. Barran, Mr. Sydney Kitson, Mr. J. E. Bedford, Mr. J. H. Wicksteed, Mr. L. Cooper, Mr. R. Wilson, Mr. A. Smithells, Mr. W. H. Thorp, Mr. W. E. Barry, Mr. A. E. Kirk, Mr. H. Thompson, Mr. W. Carby Hall, Mr. G. F. Bowman, Mr. G. B. Bulmer, Mr. T. B. Wilson, Mr. E. T. Dodgshun, and Mr. F. W. Bedford (hon. secretary). After the loyal toasts had been honoured, "The Lord Mayor and City Council" was proposed by Mr. W. H. Thorp. The Lord Mayor in responding, said that there was plenty of work for the city council to look forward to. Not many of the streets in the city were straight, and most of them ended at a short distance in a row of houses. One of the things upon which the council would be most congratulated, if they accomplished it, was the making of streets direct from the centre to the outskirts of the city. There were means of communication in some directions; but the city sorely required cross streets. He drew a comparison between the cities of Buda-Pesth and Berlin. He held that the system of small, low, back-to-back houses was not in every way to be condemned, and had a great advantage over tenement houses in crowded cities, inadequately supplied with light and air. Much as they might despise and wish to do away with back-to-back houses, there was something to be said for them. Leeds must look to the architects to assist not only in arranging the streets, but, if possible, in raising the standard of beauty and proportion to something like that of Paris. The first thing to be done was to make the streets sufficiently wide, and insist that the houses put up should be of a certain height. If the architects of Leeds could induce the building clauses committee of the city council to form a scheme which would secure that buildings of one kind were erected in one street, and buildings of another kind in another street, Leeds in the future might be admired not only for its commercial enterprise, but also for its beauty. Mr. E. Wilson gave "The Royal Institution of British Architects and Allied Societies." Mr. W. M. Fawcett and Mr. John Ely responded. "The President and the Leeds and Yorkshire Architectural Society" was given by Ald. Gordon. The Chairman responded. Mr. H. Perkin proposed "Art, Science, and Literature." The toast was responded to by Mr. M. C. W. Flower. Mr. A. T. Walker and Dr. Bodington also responded.

A builder of Lansdowne-road, East Ham, named John Jolly, aged 46, was taken to the local police-station on the evening of January 24, charged with being drunk. The next morning he met two of the constables who had been concerned in arresting him, and fired at one, whom he wounded seriously behind the right ear. An attempt to discharge his revolver a second time was frustrated. Jolly was taken before the magistrate at West Ham on Wednesday, when it was stated that the injured constable, named Hill, was still in the hospital. Jolly was remanded.

The Senatus Academicus of Edinburgh University have passed a unanimous resolution expressing in appreciative terms their sense of the value to the University of the services rendered by Dr. Rowand Anderson during a long period of years as architect of the University New Buildings, now completed by the M'Ewan Hall. They state that: "While considerations of convenience have not been sacrificed to appearance, the planning of the interior arrangements has resulted in that effective external grouping which has made the New Medical School, as a whole, an acknowledged adornment to a city famous for its architectural monuments." They add that, "the Senatus Academicus recognise that the merits of the design of the Hill entitle the architect to the lasting gratitude of the University."

At the half-yearly meeting of the Central London Railway Company, held on Wednesday, the engineers reported that good progress had been made by the Electric Traction Company with the works during the past six months, no serious hindrance to the operations having occurred. Three-fourths of the main-line tunnel had been completed, as well as one-half of the station tunnels, and nearly the whole of the lift and staircase shafts had been constructed. A very difficult work had to be undertaken—namely, the diversion of the sewers, and gas and water and other pipes, underneath the pavement at the Bank station, which was proceeding satisfactorily. Part of it was practically complete, and the public subways were well advanced. The total expenditure so far has been £1,600,000.



CONTENTS.

New Sites and Buildings ... 151  
 Amendments to the London Building Act ... 152  
 The Society of Architects ... 152  
 Surveyors' Institution Students' Preliminary Examination ... 155  
 Fireproof Construction of Domestic Buildings ... 155  
 Tile and Concrete Floor Tests ... 157  
 Construction of Arches in Concrete.—XVI ... 157  
 Wardley Hall, Lancashire ... 158  
 Obituary ... 160  
 Architectural and Archaeological Societies ... 160  
 The Building News Directory ... xi.  
 Our Illustrations ... 161  
 Competitions ... 161  
 Building Intelligence ... 180  
 Water Supply and Sanitary Matters ... 180  
 Correspondence ... 181  
 Intercommunication ... 181  
 Legal Intelligence ... 182  
 Our Office Table ... 183  
 Meetings for the Ensuing Week ... 184  
 Trade News ... 184  
 Latest Prices ... 184  
 List of Competitions Open ... 185  
 List of Tenders Open ... 185  
 Tenders ... 188

ILLUSTRATIONS.

WARDLEY HALL, LANCASHIRE.—QUEEN'S THEATRE, LEEDS.  
 —THE CHURCH OF OUR LADY, HALBERSTADT.—CHURCH OF ST. PETER AND ST. PAUL, KÖNIGSLUTTER, NEAR BRUNSWICK.—NATIONAL GOLD MEDAL DRAWING FOR STENCILLED PRIZE.—STAIRCASE IN VILLA, BERLIN.—SKETCHES OF FURNITURE.

Our Illustrations.

WARDLEY HALL, LANCASHIRE.

For description and floor plan, see page 158.

QUEEN'S THEATRE, LEEDS.

THIS new theatre at Leeds is being erected for Messrs. Morell and Mouillot and Messrs. Dottridge and Longden. The builder is Mr. S. F. Davidson, of Newcastle-on-Tyne. The building now in course of erection is situate at the corner of Meadow-road and Jack-lane, and will be faced with red bricks and stone dressings. The accompanying plan shows the arrangement of the building. The dimensions are as follows:—From curtain to back wall of pit, 72ft.; width of auditorium, 78ft.; stage, from curtain to back wall of stage, 41ft.; four exits are provided from the pit; three from the gallery, and two from the dress circle. The plan has been arranged so that one pay-office serves for the whole of the house, and the theatre will hold about 4,000. The contrivance of the frontage, so as to provide for shops, is very ingeniously managed. Messrs. W. Hope and J. C. Maxwell, of Newcastle-on-Tyne, are the architects.

CHURCH OF OUR LADY, HALBERSTADT.

THE exterior photographic view, which we are enabled to give to-day of this interesting and very ancient North German church, shows the fine western towers as seen from the adjoining gardens looking from the south east. They are thoroughly typical, and have almost a Rhinish look in their general grouping and outline. There is an extremely rich screen filled with sculpture on the north and south sides of the choir. The church itself was long disused as a place of worship during the early half of this century; it dates from 1005 A.D., and is of a Byzantine character with a vaulted chancel. It has been restored throughout, and decorated in the choir, which is separated from the nave by an iron fence.

CHURCH OF ST. PETER AND ST. PAUL, KÖNIGSLUTTER.

THE interior of the Benedictine church at Königsutter has lately been very elaborately decorated, and the view herewith published shows how the ancient sanctuary has been renovated and painted throughout. The fabric is of about the same period as its neighbour above mentioned. The church contains monuments of the Emperor Lothario and his Empress and of Henry the Proud—all ancestors of the family of Brunswick. There is a fine cloister attached to the precincts. We are indebted for these illustrations to Herr von Wasmuth's excellent

folio of photographs "Der Mittelalterlichen Baukunst in Deutschland," a work of value and interest sent us for review, and now in course of publication.

NATIONAL GOLD MEDAL DESIGN FOR A STENCILLED PRIZE AND FILLING.

THIS design, herewith reproduced, is by Mr. Geoffrey Alan Baker, of Canterbury School of Art, and in the words of the official report of the judges who awarded the medals and prizes it is described as "an extremely clever and workman-like design, which goes rather beyond what is generally advisable to attempt in stencilling; but the designer is so successful that the examiners gladly recognise the merits of his work by the award of a Gold Medal." The judges were Messrs. Lewis F. Day, Walter Crane, and Maurice B. Adams. The suggestion in the band closing off the foreground, so to speak, of the frieze proper, of rabbits in the grass, is nicely managed. There is enough delineation about them to imply more than is actually drawn, and the effect is satisfactory without the common fault of hardness. This monochrome reproduction has not the advantage of colour which constitutes so marked a feature in the original, but it gives a capital idea of the design.

STAIRCASE IN VILLA, BERLIN.

WE give, amongst our block illustrations this week, some useful details of a staircase in a Berlin residence, including a portion on the rake, with a newel surmounted by a carved eagle, and moulded and shaped circular ends to steps, also alternative newel; whilst a detail of arcade and balustrade to larger scale, with small plan, are likewise shown on the same sheet. Herr Hans Grisebach is the architect of the work.

OLD ENGLISH CLOTHES CHESTS, AND OTHER FURNITURE.

THIS sheet of sketches shows some very interesting types of furniture. The Chest of Drawers, of the William and Mary period, consists of four long drawers, each being subdivided into two panels, with a drop-handle to each. A point worthy of observation is the treatment of these panelled drawers, the panels being unshaped plain oblongs in top and third drawers, but having mitred breakings in the alternate ones. The beadings between drawers and to end stiles add to the appearance. The Dwarf Chest is of earlier date, and has lift-up top, while below is one long drawer. The half-balusters planted on, the plain arcading, and central group of panels, are ingeniously contrived, and combine to excite interest. The turned Chair is an admirable example of such work, executed with restraint, and looking thoroughly serviceable; the seat is of rushwork. The little Oak Table with the sloping legs could not easily be improved upon for "occasional" uses.

Mr. G. T. Clark, F.S.A., died on Monday night, at the age of 88 years, at his residence, Talgarn, Glamorganshire. He was a well-known antiquarian and author; an authority on earthworks and castellated structures, and also on the Roman occupation of Glamorganshire, and had for many years been manager and resident trustee of the Great Dowlais Works.

Of the 52 candidates from various parts of the country who applied for the post of city engineer to the Corporation of Liverpool, the special committee having the matter in hand selected on Monday 13 to appear before them. This committee, which will meet again on Thursday in next week, were deputed to select ten gentlemen, and when the list has been reduced to that number those applicants will be invited to go before the members of the Health Committee, who will have to make the final selection of one name for recommendation to the city council.

The half-yearly report of the directors of the London and South-Western Railway Company states that the plans for the works of the Meon Valley Railway (Alton to Fareham) are in the course of preparation and tenders for the construction of the line will now be invited. The Holsworthy and Bude Railway is approaching completion, and will be ready for traffic in July next. The order of the Light Railway Commissioners for the Basingstoke and Alton Light Railway has been confirmed by the Board of Trade, and the construction of this new line will be commenced without delay. Further widenings of the line from Nine Elms to Clapham Junction and from Woking to Basingstoke are making good progress, and the additional lines of rail between Basingstoke and Woking Junction have been brought into use.

COMPETITIONS.

WESTON-SUPER-MARE.—In a limited competition for a new Wesleyan Chapel to be built at Weston-super-Mare, the design of Mr. W. J. Morley, F.R.I.B.A., of Bradford, was accepted. The building is designed in the Decorated Gothic style, with tower and spire, and will cost about £5,000.

CHIPS.

The Brynisiencyn Board Schools, North Wales, are being warmed and ventilated by means of Shorland's patent Manchester grates, the same being supplied by Messrs. Shorland and Brother, of Manchester.

The Local Government Board has approved of the plans of the Milton Valley water scheme for the supply of Pembroke Dock and the Government Dockyard, and authorising the council to borrow £23,000 for the purpose of carrying out the works in connection with the same.

Mr. Walter A. Ducat, one of the inspectors of the Local Government Board, conducted an inquiry at the Town Hall, Bolton, on Friday, respecting an application by the town council to the Local Government Board for sanction to borrow sums of £10,255 for refuse disposal and £3,000 for technical instruction.

The new free library for Hoxton will be opened by Sir John Lubbock on March 25. It has cost £20,000, faces Pitfield-street, and has been erected from plans by Mr. H. T. Hare, selected in competition. Messrs. Dearing and Son are the builders.

The vacancy in the office of burgh surveyor in St. Andrew's caused by the appointment of Mr. Lumsden to the surveyorship of Edinburgh Suburban District, was filled up on Monday, by the election of Mr. Drummond, Master of Works, Springfield.

The Watch Committee of the Halifax Corporation have passed a resolution to be submitted to the council recommending the adoption of the plans submitted for a police-station and court-house. The various tenders amount to £13,060 8s. 6d., including £561 16s. for certain additional alterations, the total cost of the building, after deducting the sum of £326 5s. for old materials, being £12,734 3s. 6d.

The proposal to restore Brechin Cathedral at an estimated cost of £10,000 is reported to be meeting with liberal support. The committee state that already about half the required sum has been subscribed.

The widening of Davies-street at its juncture with Oxford-street, an improvement resulting from the erection of a station for the Central London Railway at that point, has just been commenced, and the existing houses are in course of demolition.

The gas committee of the corporation of Birmingham are proposing a very large scheme of capital expenditure. They contemplate the outlay of £336,000, to be spread over five years, for the reconstruction of existing works and the provision of additional works, capable, when the alterations and extensions are finished, of providing an extra supply of 10,000,000 cubic feet of gas per day. The proposals were, after some discussion, adopted by the Birmingham Corporation on Tuesday.

The Stoke-on-Trent Board of Guardians considered at their last meeting plans prepared by Mr. Charles Lynam, F.R.I.B.A., of that town, for building a new administrative block for the workhouse on the site now occupied by the infirmary, and the utilisation of the schools and site for new wards for men. There was a general expression of opinion against interfering with the schools, and ultimately Mr. Lynam was instructed to prepare a general scheme providing such accommodation as would relieve the present overcrowding and meet the requirements of the union for the next ten years, on the land at the rear of the workhouse.

The organ in Winchester Cathedral was dedicated on Thursday in last week, after reconstruction and enlargement. The instrument was originally built by Mr. Henry Willis for the Great Exhibition of 1851, where it obtained the prize; and on the recommendation of Dr. Wesley, organist of Winchester Cathedral at that time, it was bought by the Dean and Chapter in 1852. Their purchase, however, did not include the whole of the organ as it stood, and consequently there has hitherto been a want of balance in the parts. Meanwhile the daily use for forty-five years brought about a large amount of wear and tear. In 1896 Dean Stephens consulted Mr. Willis with a view to having the organ repaired, remodelled, and brought up to date. Mr. Willis, in consideration of the special interest which he felt in the organ, offered to undertake the work for the very moderate sum of £1,000. The offer was accepted, and the work has now been completed. The instrument now consists of four complete manuals from CC to G, 56 notes and 2½ octaves of concave and radiating pedals, from C C C to F, 30 notes.

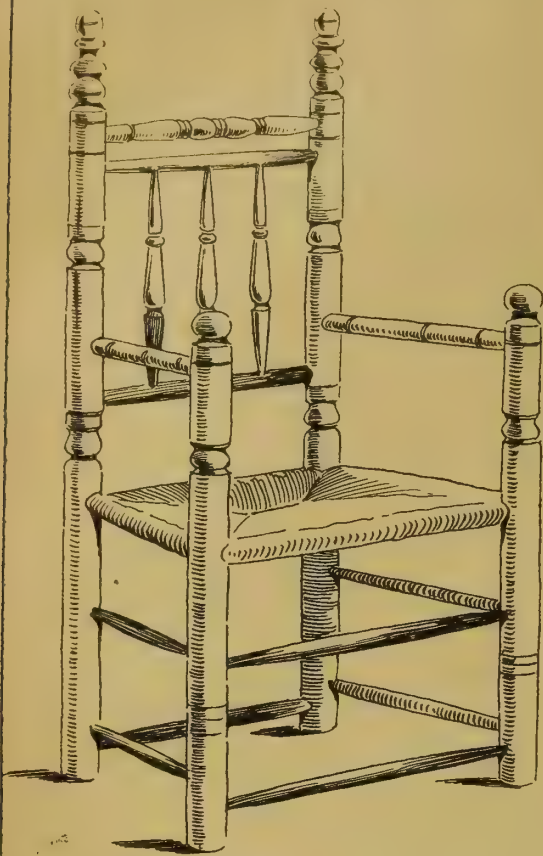

CHAIR WITH TURNED-WORK  
EARLY-SEVENTEENTH CENTURY



CHEST OF DRAWERS (TEMP. W<sup>M</sup> & MARY)

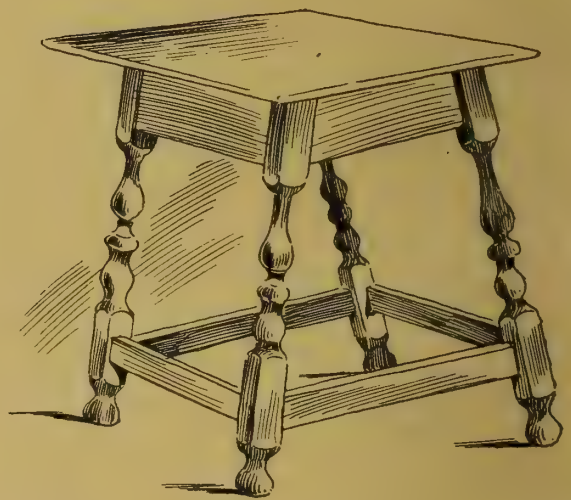

OAK TABLE  
LATE 17<sup>TH</sup> CENTURY

OLD ENGLISH  
CLOTHES-CHESTS  
AND  
OTHER FURNITURE

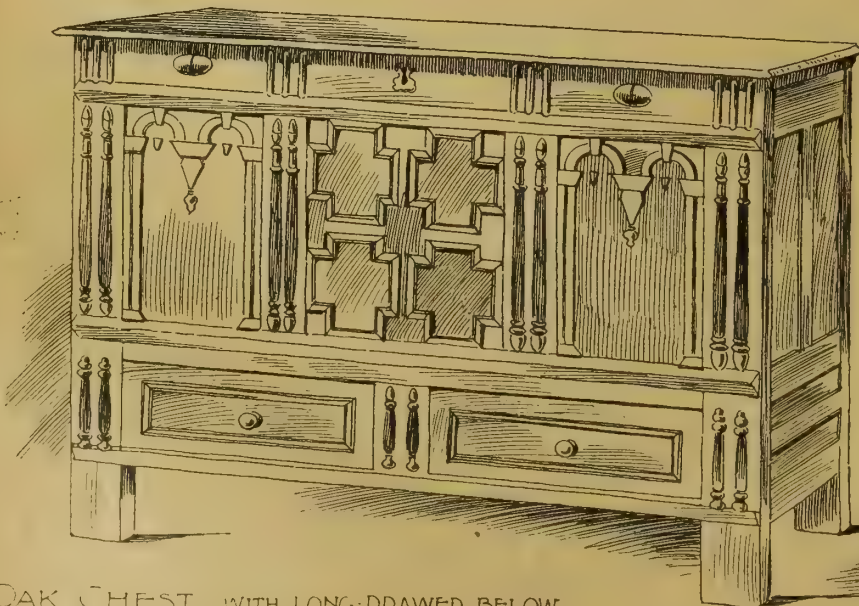

OAK CHEST WITH LONG-DRAWER BELOW





WARDLEY-HALL · LANCASHIRE · AS · RESTORED · JOHN · DOUGLAS · ARCHT

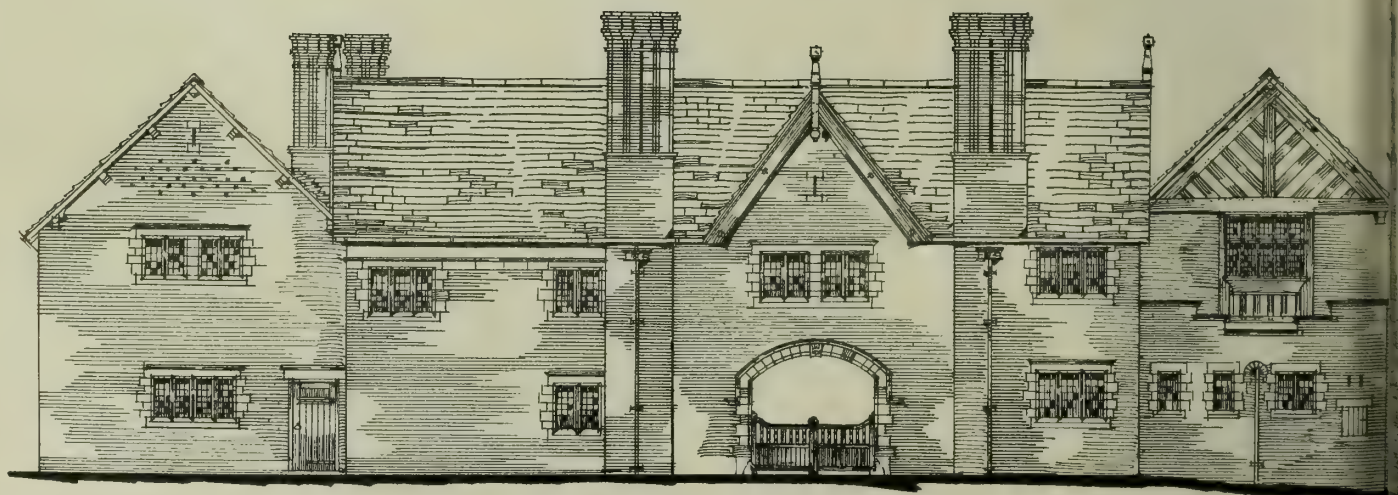

North Elevation.

Scale 30 feet.

Wardley Hall: Lancashire

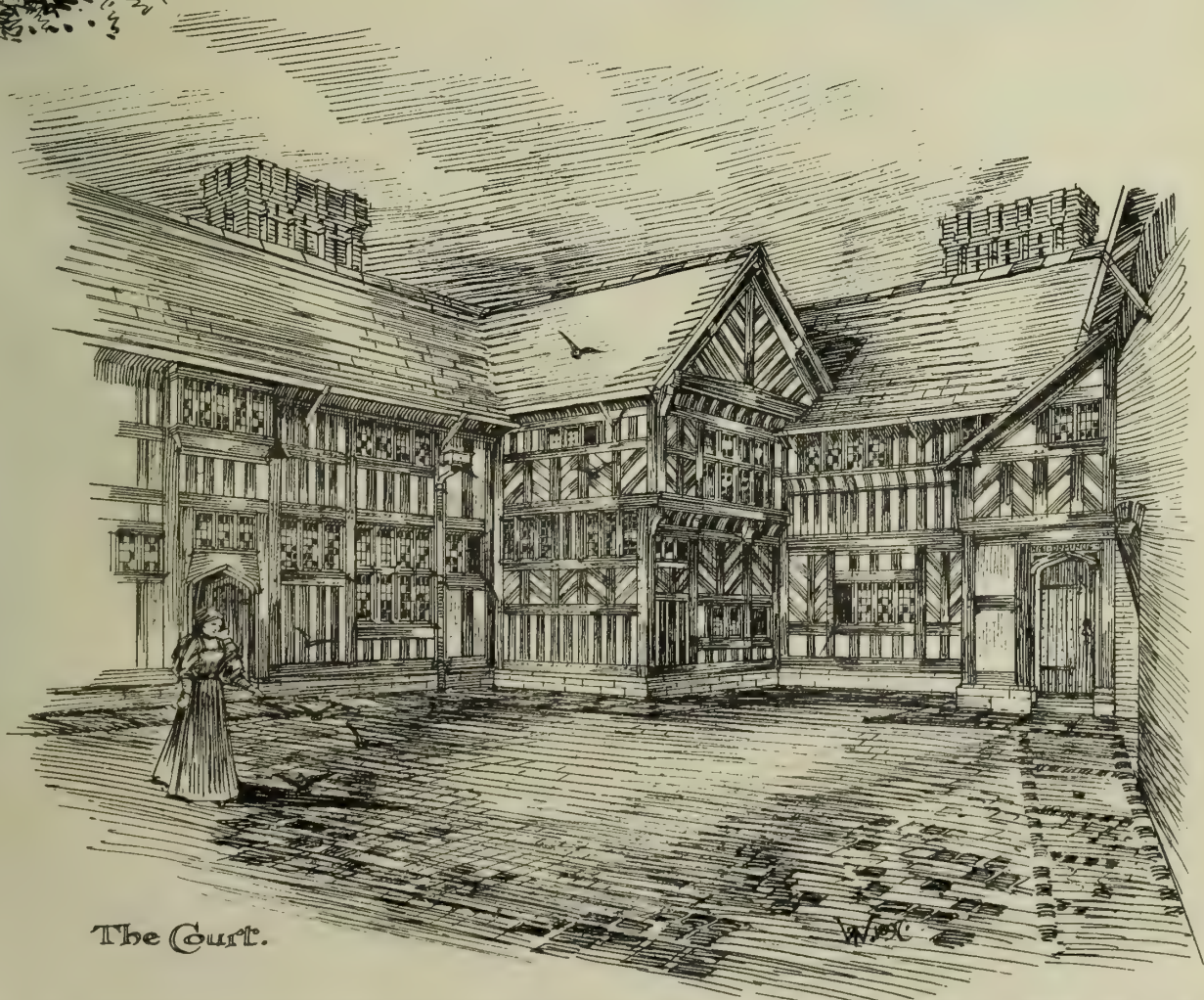
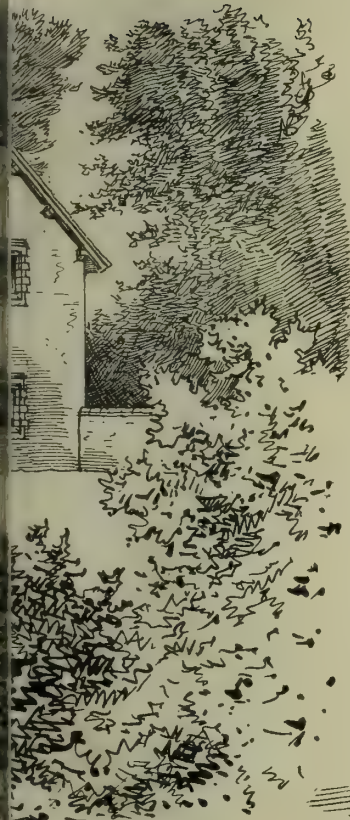







THE CHURCH OF OUR LADY · HALBERSTADT ·



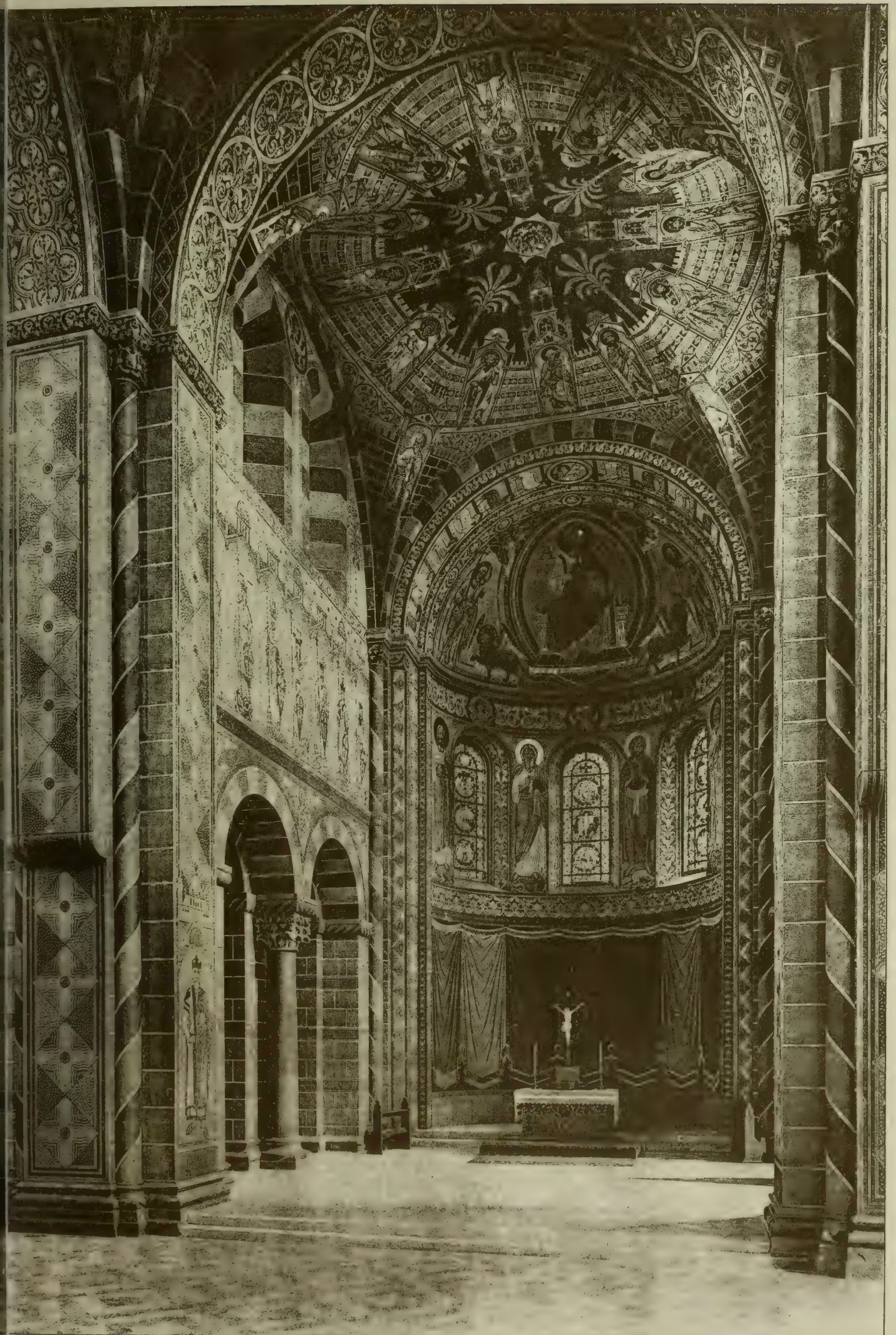

"PHOTO-TINT" by James Akerman 6, Queen Square London W.

CHURCH OF ST. PETER & ST. PAUL. KÖNIGSLUTTER. NR BRUNSWICK.

INTERIOR OF CHURCH.





QUEEN'S THEATRE, LEEDS,  
for Messrs DODDGE & LONGDEN,  
Messrs FRORELL & TRUILLIST.

W. HOPC.  
J. C. T. OSWELL, ARCHT.  
NEWCASTLE on Tyne.

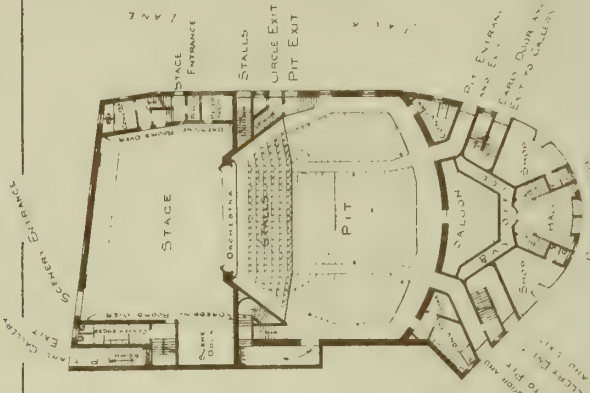

PLAN AT PIT LEVEL

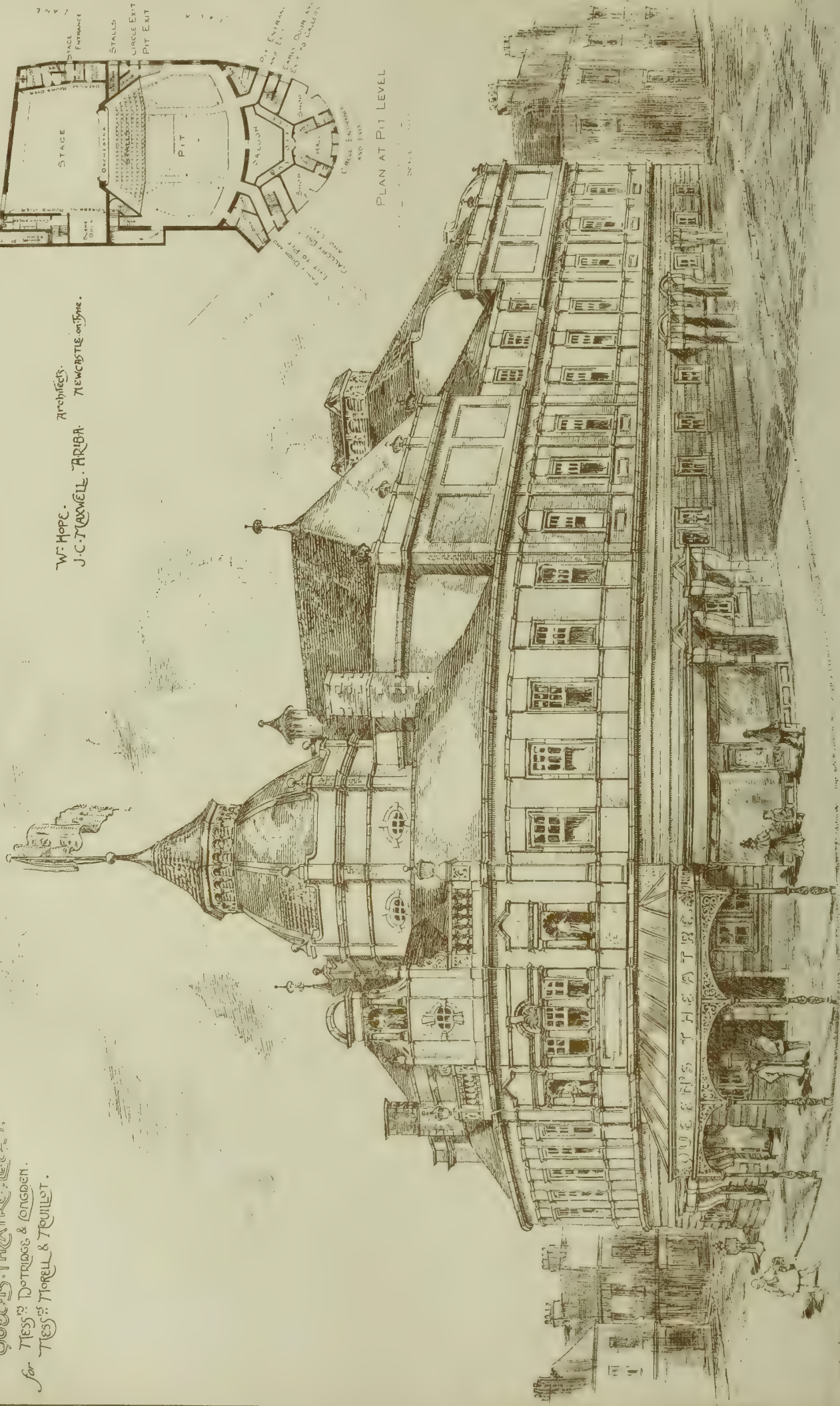





Section thro' Stables.

North Elevation: Court.

Section thro' Kitchen.

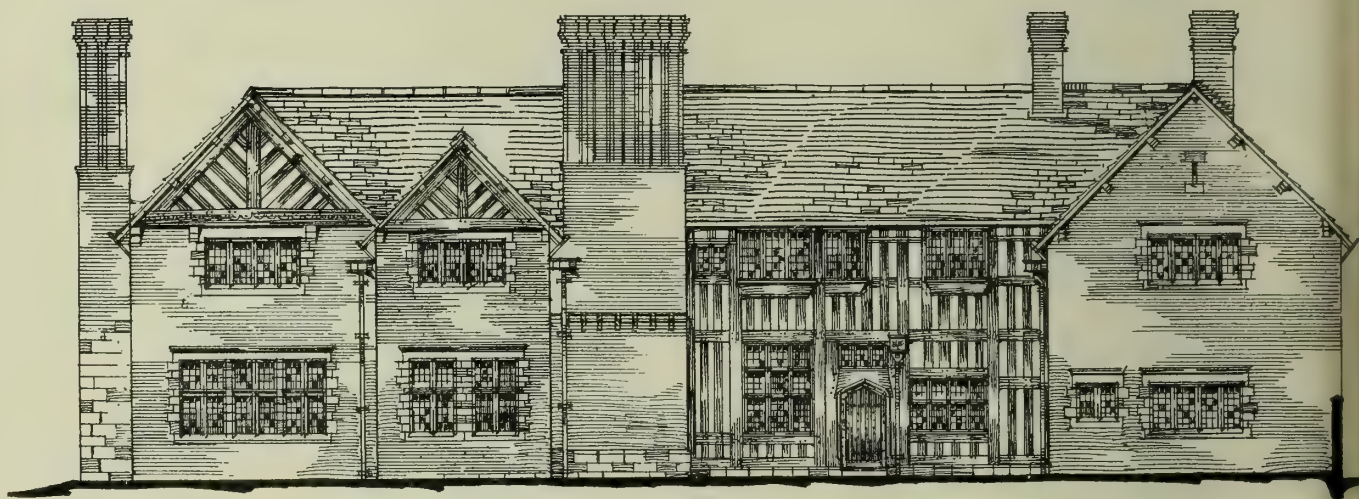

South Elevation.



Section thro' Hall.

East Elevation: Court.

Section thro' Gallery.

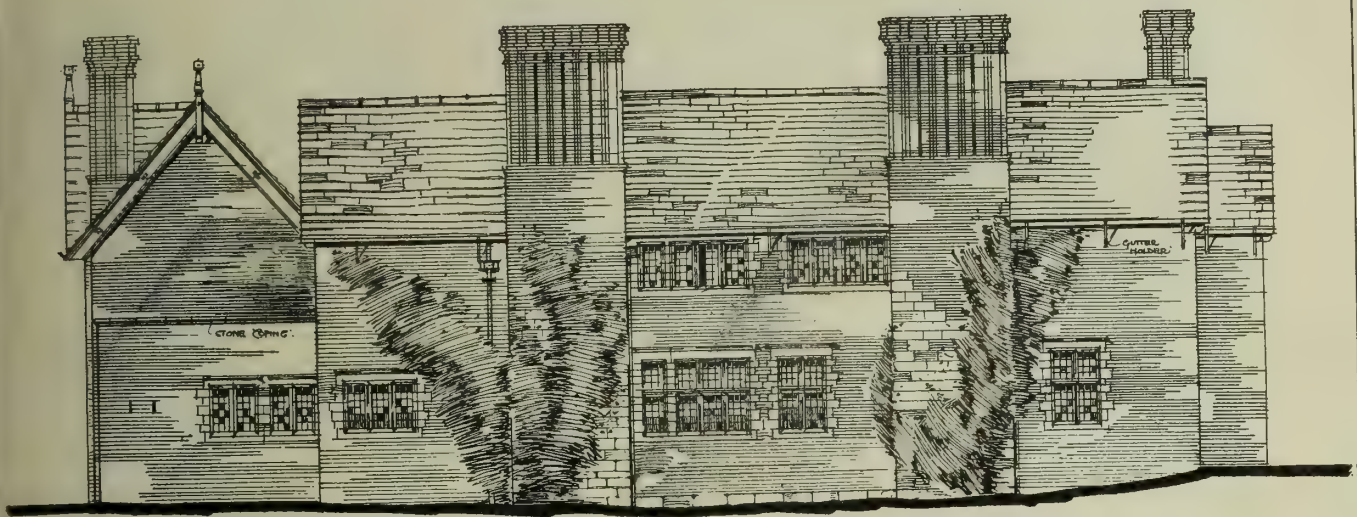

West Elevation.

Scale  feet.



WARDLEY HALL · LANCASHIRE · AS RESTORED · JOHN DOUGLAS ARCHT

North Elevation.

 feet.

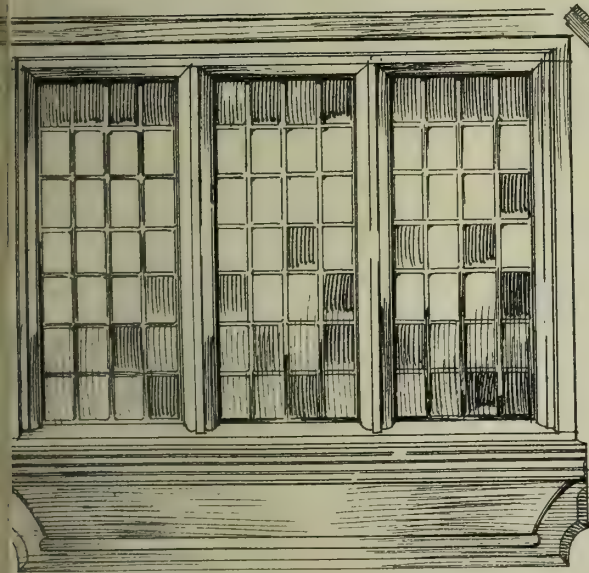

Window in Framing: Garden Front.  
Elevation

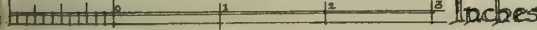
 Inches.

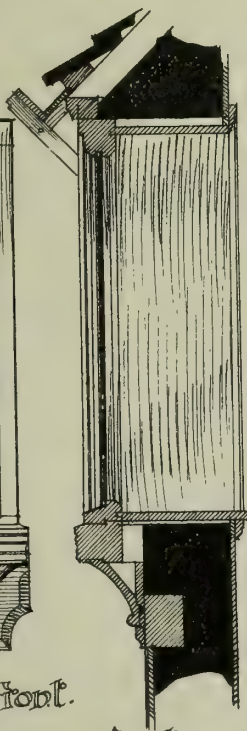

Section.

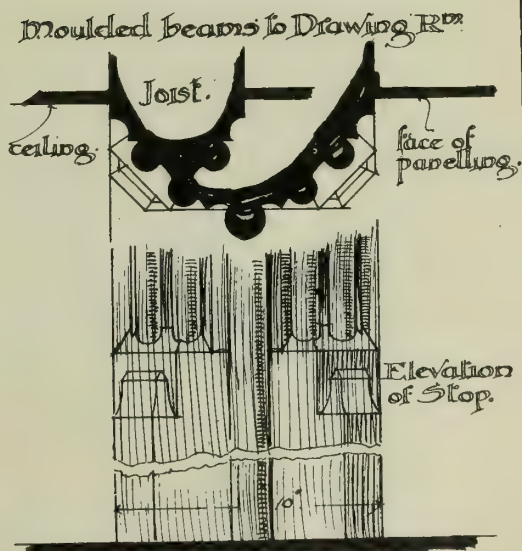

Moulded beams to Drawing Rm.  
Jost.  
ceiling.  
face of panelling.

Elevation of Stop.



Josts.

Moulded beams to Hall.

Wardley Hall: Lancashire.





THE BUILDING DEWS. FEB. 4. 1898.

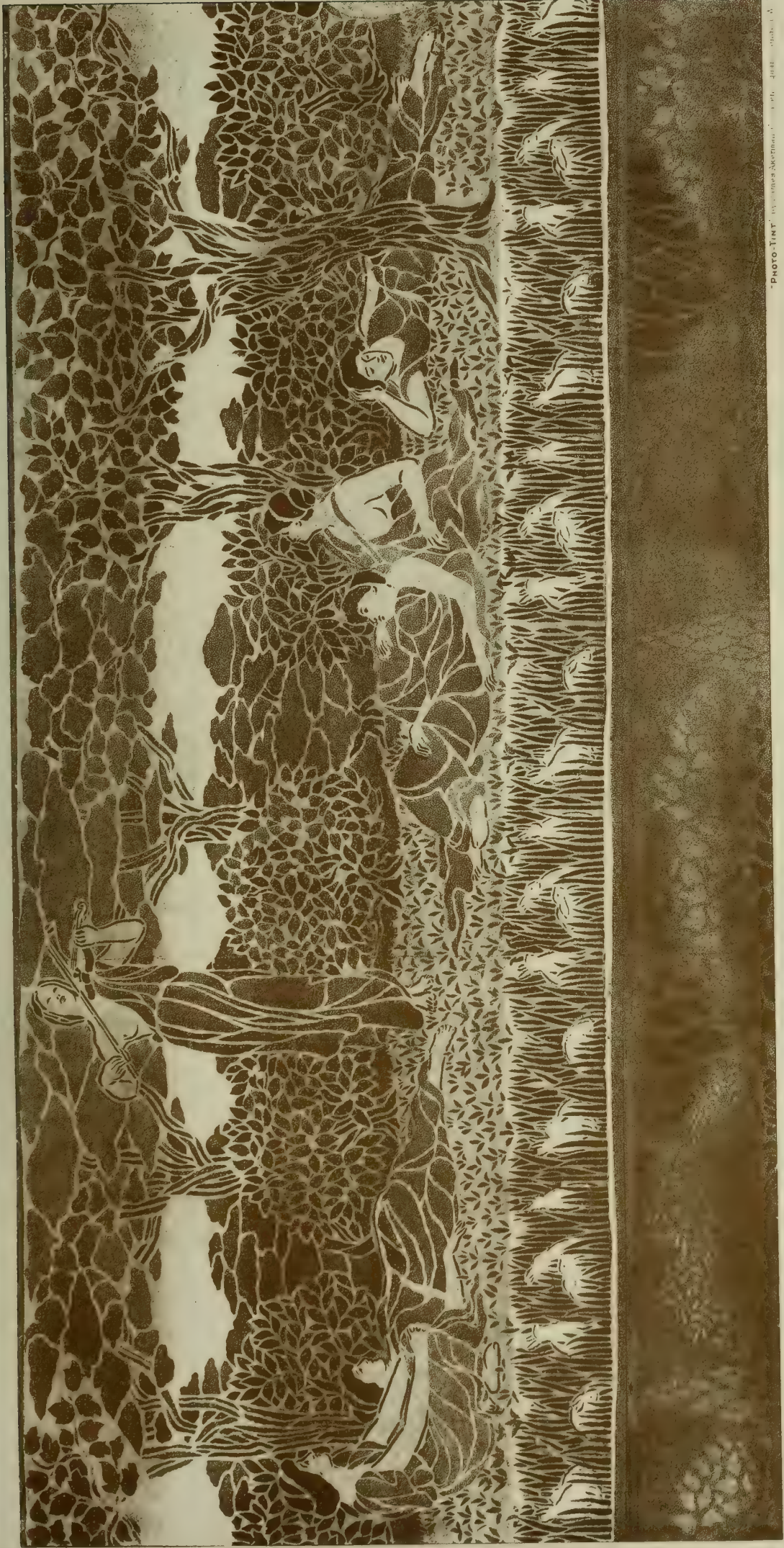

"PHOTO-TINT" by the Messrs. Skelton, 11, 13, 15, 17, 19, 21, 23, 25, 27, 29, 31, 33, 35, 37, 39, 41, 43, 45, 47, 49, 51, 53, 55, 57, 59, 61, 63, 65, 67, 69, 71, 73, 75, 77, 79, 81, 83, 85, 87, 89, 91, 93, 95, 97, 99, 101, 103, 105, 107, 109, 111, 113, 115, 117, 119, 121, 123, 125, 127, 129, 131, 133, 135, 137, 139, 141, 143, 145, 147, 149, 151, 153, 155, 157, 159, 161, 163, 165, 167, 169, 171, 173, 175, 177, 179, 181, 183, 185, 187, 189, 191, 193, 195, 197, 199, 201, 203, 205, 207, 209, 211, 213, 215, 217, 219, 221, 223, 225, 227, 229, 231, 233, 235, 237, 239, 241, 243, 245, 247, 249, 251, 253, 255, 257, 259, 261, 263, 265, 267, 269, 271, 273, 275, 277, 279, 281, 283, 285, 287, 289, 291, 293, 295, 297, 299, 301, 303, 305, 307, 309, 311, 313, 315, 317, 319, 321, 323, 325, 327, 329, 331, 333, 335, 337, 339, 341, 343, 345, 347, 349, 351, 353, 355, 357, 359, 361, 363, 365, 367, 369, 371, 373, 375, 377, 379, 381, 383, 385, 387, 389, 391, 393, 395, 397, 399, 401, 403, 405, 407, 409, 411, 413, 415, 417, 419, 421, 423, 425, 427, 429, 431, 433, 435, 437, 439, 441, 443, 445, 447, 449, 451, 453, 455, 457, 459, 461, 463, 465, 467, 469, 471, 473, 475, 477, 479, 481, 483, 485, 487, 489, 491, 493, 495, 497, 499, 501, 503, 505, 507, 509, 511, 513, 515, 517, 519, 521, 523, 525, 527, 529, 531, 533, 535, 537, 539, 541, 543, 545, 547, 549, 551, 553, 555, 557, 559, 561, 563, 565, 567, 569, 571, 573, 575, 577, 579, 581, 583, 585, 587, 589, 591, 593, 595, 597, 599, 601, 603, 605, 607, 609, 611, 613, 615, 617, 619, 621, 623, 625, 627, 629, 631, 633, 635, 637, 639, 641, 643, 645, 647, 649, 651, 653, 655, 657, 659, 661, 663, 665, 667, 669, 671, 673, 675, 677, 679, 681, 683, 685, 687, 689, 691, 693, 695, 697, 699, 701, 703, 705, 707, 709, 711, 713, 715, 717, 719, 721, 723, 725, 727, 729, 731, 733, 735, 737, 739, 741, 743, 745, 747, 749, 751, 753, 755, 757, 759, 761, 763, 765, 767, 769, 771, 773, 775, 777, 779, 781, 783, 785, 787, 789, 791, 793, 795, 797, 799, 801, 803, 805, 807, 809, 811, 813, 815, 817, 819, 821, 823, 825, 827, 829, 831, 833, 835, 837, 839, 841, 843, 845, 847, 849, 851, 853, 855, 857, 859, 861, 863, 865, 867, 869, 871, 873, 875, 877, 879, 881, 883, 885, 887, 889, 891, 893, 895, 897, 899, 901, 903, 905, 907, 909, 911, 913, 915, 917, 919, 921, 923, 925, 927, 929, 931, 933, 935, 937, 939, 941, 943, 945, 947, 949, 951, 953, 955, 957, 959, 961, 963, 965, 967, 969, 971, 973, 975, 977, 979, 981, 983, 985, 987, 989, 991, 993, 995, 997, 999, 1001, 1003, 1005, 1007, 1009, 1011, 1013, 1015, 1017, 1019, 1021, 1023, 1025, 1027, 1029, 1031, 1033, 1035, 1037, 1039, 1041, 1043, 1045, 1047, 1049, 1051, 1053, 1055, 1057, 1059, 1061, 1063, 1065, 1067, 1069, 1071, 1073, 1075, 1077, 1079, 1081, 1083, 1085, 1087, 1089, 1091, 1093, 1095, 1097, 1099, 1101, 1103, 1105, 1107, 1109, 1111, 1113, 1115, 1117, 1119, 1121, 1123, 1125, 1127, 1129, 1131, 1133, 1135, 1137, 1139, 1141, 1143, 1145, 1147, 1149, 1151, 1153, 1155, 1157, 1159, 1161, 1163, 1165, 1167, 1169, 1171, 1173, 1175, 1177, 1179, 1181, 1183, 1185, 1187, 1189, 1191, 1193, 1195, 1197, 1199, 1201, 1203, 1205, 1207, 1209, 1211, 1213, 1215, 1217, 1219, 1221, 1223, 1225, 1227, 1229, 1231, 1233, 1235, 1237, 1239, 1241, 1243, 1245, 1247, 1249, 1251, 1253, 1255, 1257, 1259, 1261, 1263, 1265, 1267, 1269, 1271, 1273, 1275, 1277, 1279, 1281, 1283, 1285, 1287, 1289, 1291, 1293, 1295, 1297, 1299, 1301, 1303, 1305, 1307, 1309, 1311, 1313, 1315, 1317, 1319, 1321, 1323, 1325, 1327, 1329, 1331, 1333, 1335, 1337, 1339, 1341, 1343, 1345, 1347, 1349, 1351, 1353, 1355, 1357, 1359, 1361, 1363, 1365, 1367, 1369, 1371, 1373, 1375, 1377, 1379, 1381, 1383, 1385, 1387, 1389, 1391, 1393, 1395, 1397, 1399, 1401, 1403, 1405, 1407, 1409, 1411, 1413, 1415, 1417, 1419, 1421, 1423, 1425, 1427, 1429, 1431, 1433, 1435, 1437, 1439, 1441, 1443, 1445, 1447, 1449, 1451, 1453, 1455, 1457, 1459, 1461, 1463, 1465, 1467, 1469, 1471, 1473, 1475, 1477, 1479, 1481, 1483, 1485, 1487, 1489, 1491, 1493, 1495, 1497, 1499, 1501, 1503, 1505, 1507, 1509, 1511, 1513, 1515, 1517, 1519, 1521, 1523, 1525, 1527, 1529, 1531, 1533, 1535, 1537, 1539, 1541, 1543, 1545, 1547, 1549, 1551, 1553, 1555, 1557, 1559, 1561, 1563, 1565, 1567, 1569, 1571, 1573, 1575, 1577, 1579, 1581, 1583, 1585, 1587, 1589, 1591, 1593, 1595, 1597, 1599, 1601, 1603, 1605, 1607, 1609, 1611, 1613, 1615, 1617, 1619, 1621, 1623, 1625, 1627, 1629, 1631, 1633, 1635, 1637, 1639, 1641, 1643, 1645, 1647, 1649, 1651, 1653, 1655, 1657, 1659, 1661, 1663, 1665, 1667, 1669, 1671, 1673, 1675, 1677, 1679, 1681, 1683, 1685, 1687, 1689, 1691, 1693, 1695, 1697, 1699, 1701, 1703, 1705, 1707, 1709, 1711, 1713, 1715, 1717, 1719, 1721, 1723, 1725, 1727, 1729, 1731, 1733, 1735, 1737, 1739, 1741, 1743, 1745, 1747, 1749, 1751, 1753, 1755, 1757, 1759, 1761, 1763, 1765, 1767, 1769, 1771, 1773, 1775, 1777, 1779, 1781, 1783, 1785, 1787, 1789, 1791, 1793, 1795, 1797, 1799, 1801, 1803, 1805, 1807, 1809, 1811, 1813, 1815, 1817, 1819, 1821, 1823, 1825, 1827, 1829, 1831, 1833, 1835, 1837, 1839, 1841, 1843, 1845, 1847, 1849, 1851, 1853, 1855, 1857, 1859, 1861, 1863, 1865, 1867, 1869, 1871, 1873, 1875, 1877, 1879, 1881, 1883, 1885, 1887, 1889, 1891, 1893, 1895, 1897, 1899, 1901, 1903, 1905, 1907, 1909, 1911, 1913, 1915, 1917, 1919, 1921, 1923, 1925, 1927, 1929, 1931, 1933, 1935, 1937, 1939, 1941, 1943, 1945, 1947, 1949, 1951, 1953, 1955, 1957, 1959, 1961, 1963, 1965, 1967, 1969, 1971, 1973, 1975, 1977, 1979, 1981, 1983, 1985, 1987, 1989, 1991, 1993, 1995, 1997, 1999, 2001, 2003, 2005, 2007, 2009, 2011, 2013, 2015, 2017, 2019, 2021, 2023, 2025, 2027, 2029, 2031, 2033, 2035, 2037, 2039, 2041, 2043, 2045, 2047, 2049, 2051, 2053, 2055, 2057, 2059, 2061, 2063, 2065, 2067, 2069, 2071, 2073, 2075, 2077, 2079, 2081, 2083, 2085, 2087, 2089, 2091, 2093, 2095, 2097, 2099, 2101, 2103, 2105, 2107, 2109, 2111, 2113, 2115, 2117, 2119, 2121, 2123, 2125, 2127, 2129, 2131, 2133, 2135, 2137, 2139, 2141, 2143, 2145, 2147, 2149, 2151, 2153, 2155, 2157, 2159, 2161, 2163, 2165, 2167, 2169, 2171, 2173, 2175, 2177, 2179, 2181, 2183, 2185, 2187, 2189, 2191, 2193, 2195, 2197, 2199, 2201, 2203, 2205, 2207, 2209, 2211, 2213, 2215, 2217, 2219, 2221, 2223, 2225, 2227, 2229, 2231, 2233, 2235, 2237, 2239, 2241, 2243, 2245, 2247, 2249, 2251, 2253, 2255, 2257, 2259, 2261, 2263, 2265, 2267, 2269, 2271, 2273, 2275, 2277, 2279, 2281, 2283, 2285, 2287, 2289, 2291, 2293, 2295, 2297, 2299, 2301, 2303, 2305, 2307, 2309, 2311, 2313, 2315, 2317, 2319, 2321, 2323, 2325, 2327, 2329, 2331, 2333, 2335, 2337, 2339, 2341, 2343, 2345, 2347, 2349, 2351, 2353, 2355, 2357, 2359, 2361, 2363, 2365, 2367, 2369, 2371, 2373, 2375, 2377, 2379, 2381, 2383, 2385, 2387, 2389, 2391, 2393, 2395, 2397, 2399, 2401, 2403, 2405, 2407, 2409, 2411, 2413, 2415, 2417, 2419, 2421, 2423, 2425, 2427, 2429, 2431, 2433, 2435, 2437, 2439, 2441, 2443, 2445, 2447, 2449, 2451, 2453, 2455, 2457, 2459, 2461, 2463, 2465, 2467, 2469, 2471, 2473, 2475, 2477, 2479, 2481, 2483, 2485, 2487, 2489, 2491, 2493, 2495, 2497, 2499, 2501, 2503, 2505, 2507, 2509, 2511, 2513, 2515, 2517, 2519, 2521, 2523, 2525, 2527, 2529, 2531, 2533, 2535, 2537, 2539, 2541, 2543, 2545, 2547, 2549, 2551, 2553, 2555, 2557, 2559, 2561, 2563, 2565, 2567, 2569, 2571, 2573, 2575, 2577, 2579, 2581, 2583, 2585, 2587, 2589, 2591, 2593, 2595, 2597, 2599, 2601, 2603, 2605, 2607, 2609, 2611, 2613, 2615, 2617, 2619, 2621, 2623, 2625, 2627, 2629, 2631, 2633, 2635, 2637, 2639, 2641, 2643, 2645, 2647, 2649, 2651, 2653, 2655, 2657, 2659, 2661, 2663, 2665, 2667, 2669, 2671, 2673, 2675, 2677, 2679, 2681, 2683, 2685, 2687, 2689, 2691, 2693, 2695, 2697, 2699, 2701, 2703, 2705, 2707, 2709, 2711, 2713, 2715, 2717, 2719, 2721, 2723, 2725, 2727, 2729, 2731, 2733, 2735, 2737, 2739, 2741, 2743, 2745, 2747, 2749, 2751, 2753, 2755, 2757, 2759, 2761, 2763, 2765, 2767, 2769, 2771, 2773, 2775, 2777, 2779, 2781, 2783, 2785, 2787, 2789, 2791, 2793, 2795, 2797, 2799, 2801, 2803, 2805, 2807, 2809, 2811, 2813, 2815, 2817, 2819, 2821, 2823, 2825, 2827, 2829, 2831, 2833, 2835, 2837, 2839, 2841, 2843, 2845, 2847, 2849, 2851, 2853, 2855, 2857, 2859, 2861, 2863, 2865, 2867, 2869, 2871, 2873, 2875, 2877, 2879, 2881, 2883, 2885, 2887, 2889, 2891, 2893, 2895, 2897, 2899, 2901, 2903, 2905, 2907, 2909, 2911, 2913, 2915, 2917, 2919, 2921, 2923, 2925, 2927, 2929, 2931, 2933, 2935, 2937, 2939, 2941, 2943, 2945, 2947, 2949, 2951, 2953, 2955, 2957, 2959, 2961, 2963, 2965, 2967, 2969, 2971, 2973, 2975, 2977, 2979, 2981, 2983, 2985, 2987, 2989, 2991, 2993, 2995, 2997, 2999, 3001, 3003, 3005, 3007, 3009, 3011, 3013, 3015, 3017, 3019, 3021, 3023, 3025, 3027, 3029, 3031, 3033, 3035, 3037, 3039, 3041, 3043, 3045, 3047, 3049, 3051, 3053, 3055, 3057, 3059, 3061, 3063, 3065, 3067, 3069, 3071, 3073, 3075, 3077, 3079, 3081, 3083, 3085, 3087, 3089, 3091, 3093, 3095, 3097, 3099, 3101, 3103, 3105, 3107, 3109, 3111, 3113, 3115, 3117, 3119, 3121, 3123, 3125, 3127, 3129, 3131, 3133, 3135, 3137, 3139, 3141, 3143, 3145, 3147, 3149, 3151, 3153, 3155, 3157, 3159, 3161, 3163, 3165, 3167, 3169, 3171, 3173, 3175, 3177, 3179, 3181, 3183, 3185, 3187, 3189, 3191, 3193, 3195, 3197, 3199, 3201, 3203, 3205, 3207, 3209, 3211, 3213, 3215, 3217, 3219, 3221, 3223, 3225, 3227, 3229, 3231, 3233, 3235, 3237, 3239, 3241, 3243, 3245, 3247, 3249, 3251, 3253, 3255, 3257, 3259, 3261, 3263, 3265, 3267, 3269, 3271, 3273, 3275, 3277, 3279, 3281, 3283, 3285, 3287, 3289, 3291, 3293, 3295, 3297, 3299, 3301, 3303, 3305, 3307, 3309, 3311, 3313, 3315, 3317, 3319, 3321, 3323, 3325, 3327, 3329, 3331, 3333, 3335, 3337, 3339, 3341, 3343, 3345, 3347, 3349, 3351, 3353, 3355, 3357, 3359, 3361, 3363, 3365, 3367, 3369, 3371, 3373, 3375, 3377, 3379, 3381, 3383, 3385, 3387, 3389, 3391, 3393, 3395, 3397, 3399, 3401, 3403, 3405, 3407, 3409, 3411, 3413, 3415, 3417, 3419, 3421, 3423, 3425, 3427, 3429, 3431, 3433, 3435, 3437, 3439, 3441, 3443, 3445, 3447, 3449, 3451, 3453, 3455, 3457, 3459, 3461, 3463, 3465, 3467, 3469, 3471, 3473, 3475, 3477, 3479, 3481, 3483, 3485, 3487, 3489, 3491, 3493, 3495, 3497, 3499, 3501, 3503, 3505, 3507, 3509, 3511, 3513, 3515, 3517, 3519, 3521, 3523, 3525, 3527, 3529, 3531, 3533, 3535, 3537, 3539, 3541, 3543, 3545, 3547, 3549, 3551, 3553, 3555, 3557, 3559, 3561, 3563, 3565, 3567, 3569, 3571, 3573, 3575, 3577, 3579, 3581, 3583, 3585, 3587, 3589, 3591, 3593, 3595, 3597, 3599, 3601, 3603, 3605, 3607, 3609, 3611, 3613, 3615, 3617, 3619, 3621, 3623, 3625, 3627, 3629, 3631, 3633, 3635, 3637, 3639, 3641, 3643, 3645, 3647, 3649, 3651, 3653, 3655, 3657, 3659, 3661, 3663, 3665, 3667, 3669, 3671, 3673, 3675, 3677, 3679, 3681, 3683, 3685, 3687, 3689, 3691, 3693, 3695, 3697, 3699, 3701, 3703, 3705, 3707, 3709, 3711, 3713, 3715, 3717, 3719, 3721, 3723, 3725, 3727, 3729, 3731, 3733, 3735, 3737, 3739, 3741, 3743, 3745, 3747, 3749, 3751, 3753, 3755, 3757, 3759, 3761, 3763, 3765, 3767, 3769, 3771, 3773, 3775, 3777, 3779, 3781, 3783, 3785, 3787, 3789, 3791, 3793, 3795, 3797, 3799, 3801, 3803, 3805, 3807, 3809, 3811, 3813, 3815, 3817, 3819, 3821, 3823, 3825, 3827, 3829, 3831, 3833, 3835, 3837, 3839, 3841, 3843, 3845, 3847, 3849, 3851, 3853, 3855, 3857, 3859, 3861, 3863, 3865, 3867, 3869, 3871, 3873, 3875, 3877, 3879, 3881, 3883, 3885, 3887, 3889, 3891, 3893, 3895, 3897, 3899, 3901, 3903, 3905, 3907, 3909, 3911, 3913, 3915, 3917, 3919, 3921, 3923, 3925, 3927, 3929, 3931, 3933, 3935, 3937, 3939, 3941, 3943, 3945, 3947, 3949, 3951, 3953, 3955, 3957, 3959, 3961, 3963, 3965, 3967, 3969, 3971, 3973, 3975, 3977, 3979, 3981, 3983, 3985, 3987, 3989, 3991, 3993, 3995, 3997, 3999, 4001, 4003, 4005, 4007, 4009, 4011, 4013, 4015, 4017, 4019, 4021, 4023, 4025, 4027, 4029, 4031, 4033, 4035, 4037, 4039, 4041, 4043, 4045, 4047, 4049, 4051, 4053, 4055, 4057, 4059, 4061, 4063, 4065, 4067, 4069, 4071, 4073, 4075, 4077, 4079, 4081, 4083, 4085, 4087, 4089, 4091, 4093, 4095, 4097, 4099, 4101, 4103, 4105, 4107, 4109, 4111, 4113, 4115, 4117, 4119, 4121, 4123, 4125, 4127, 4129, 4131, 4133, 4135, 4137, 4139, 4141, 4143, 4145, 4147, 4149, 4151, 4153, 4155, 4157, 4159, 4161, 4163, 4165, 4167, 4169, 4171, 4173, 4175, 4177, 4179, 4181, 4183, 4185, 4187, 4189, 4191, 4193, 4195, 4197, 4199, 4201, 4203, 4205, 4207, 4209, 4211, 4213, 4215, 4217, 4219, 4221, 4223, 4225, 4227, 4229,



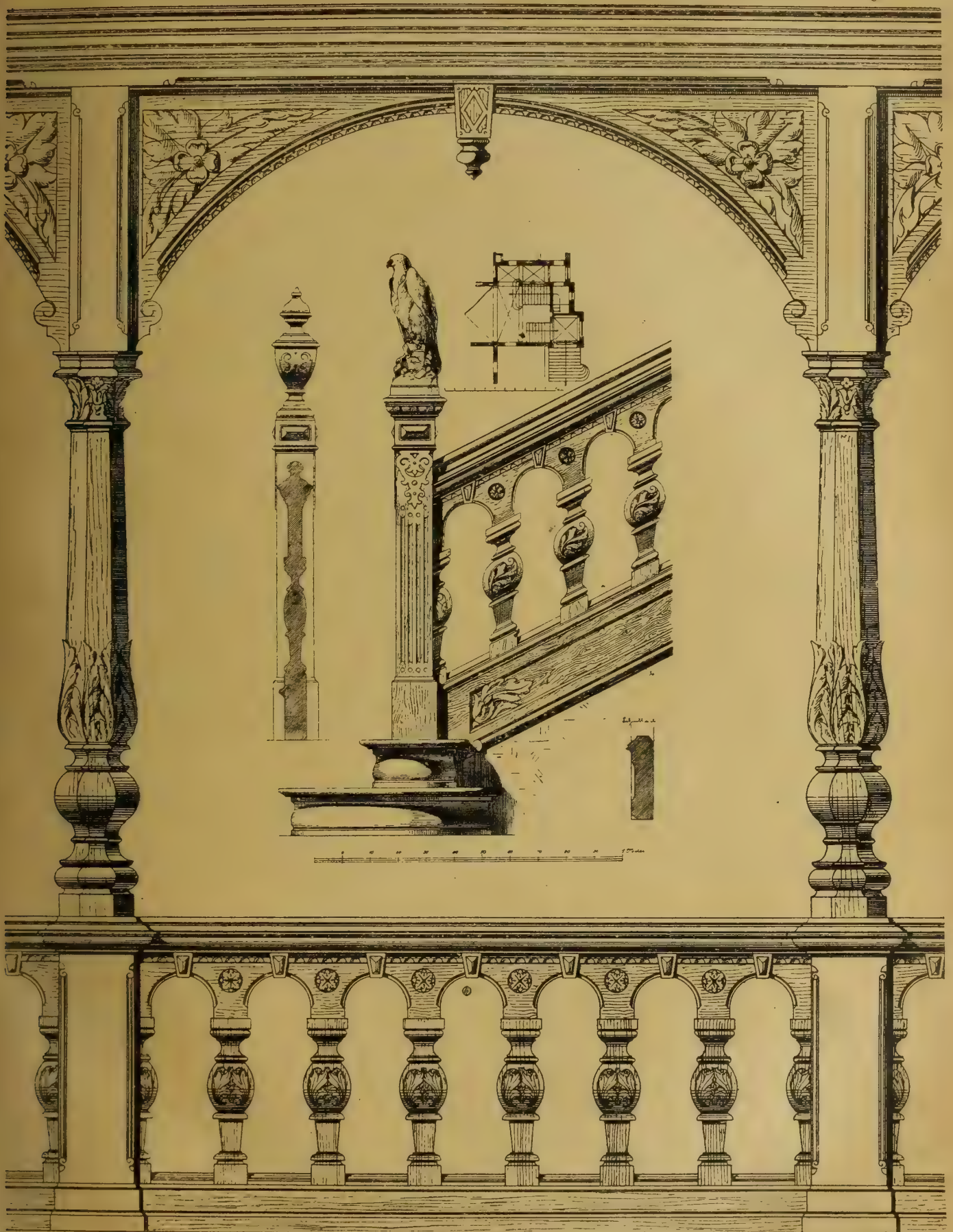

STAIRCASE IN VILLA, BERLIN.

## Building Intelligence.

**BARRY.**—The opening services of the new Wesleyan Chapel, which has been erected on the brow of the hill overlooking Barry, were commenced last week. The structure has been built at a cost of about £3,400 by Messrs. E. R. Evans Bros., of Cardiff, from plans prepared by Mr. Budgeon, of the firm of Jones, Richards, and Budgeon, architects, Cardiff. The elevations are of Newbridge stone, with Bath stone dressings, the style adopted being Early Perpendicular. The ornamentation, however, is almost limited to the treatment of the central part of the front elevation. The width of the chapel at the transepts is greater than the length of the building from lobby to choir. Sitting accommodation is provided for 624 persons upon the ground floor, and when the galleries are erected the accommodation will be increased to about 1,100. The choir seats are behind the rostrum, and will accommodate 46, with space for organ in addition. There are two vestries for the choir and minister, both rooms having access to a large parlour. There are no gallery supports and columns from the same to help to carry the roof, which is in one span, light Bath stone pilasters carrying the ends of roof trusses. A feature in the chapel is that Jarrahdale Jarrah wood has been introduced as wood-block flooring in the passages and elsewhere.

**CLECKHEATON.**—The new Liberal Club at Cleckheaton, in the Spen Valley Division, was opened by Sir Henry Fowler, M.P., on Friday. The club is a building of two stories, in the Renaissance style, and, exclusive of site and furniture, has cost £2,500. The site cost about £1,100. There is a ashlar stone frontage to the main elevation near Northgate, and which has millioned and transomed windows. Above the entrance is a balcony, to which access is obtained from one of the upper rooms. To the right of the entrance is a reading-room, 28ft. by 17½ft., with a floor of wood blocks; opposite is the committee-room, 17½ft. by 15½ft. The assembly-room, on the same floor, is 36ft. by 28ft., and accommodates 180 persons. On the second floor there are two billiard-rooms, a bar, card-room, and lavatories. The building has been erected from the designs of Mr. Reuben Castle, architect, Cleckheaton.

**EDINBURGH.**—The North British Railway Company recently resolved that the whole of the large building now rising at the corner of North Bridge-street and Princes-street should be devoted to hotel purposes. When the plans were first drawn they showed part of the building allocated as offices for the manager, secretary, superintendent, engineer, and their respective staffs. The change has been made in order that the architect, Mr. W. Beattie Hamilton, might have a free hand to arrange the interior of the building in a symmetrical fashion, and provide for more bedrooms for visitors. The Dean of Guild Court and the railway directors have now finally sanctioned the plans, and the work will now be proceeded with. The whole of the street level on the south side of the building overlooking the station will now be appropriated for ball-room accommodation. The principal ballroom will be 120ft. by 36ft.; there is another 72ft. by 30ft., and a third 42ft. by 25ft. Associated with these will be a series of cloak and retiring rooms, and service and other rooms necessary for carrying on the entertainment part of the business. On the first floor of the building, which is 185ft. square, there is a corridor on each side, which, at the angles, breaks out into a circular connecting hall. It has also been determined that the whole building shall be of fireproof construction from top to basement. Originally the plan of the hotel showed 370 bedrooms for visitors. By the arrangements now made there will be 400 bedrooms of this description, and about 150 bedrooms more for the hotel staff. There will be no alteration on the elevations. The property facing Princes-street will be pulled down after Whitsuntide, and the hotel will proceed simultaneously on all sides at once. The North British staff will by that time have taken up their quarters in the Waterloo Hotel, which will be adapted to their wants.

**IPSWICH.**—A new hall in connection with, and adjoining the Social Settlement Buildings in Fore-street, Ipswich, was opened on Tuesday by the Dean of Norwich, Dr. Lefroy. The hall has been built at the sole cost of Mr. D. Ford

Goddard, M.P., and seats 650 persons. It is 69ft. long (exclusive of a platform recess and an organ-chamber), 41ft. broad, and 30ft. high to the ridge of the roof. The latter is shaped hexagonally, and starts 17ft. from the floor. It is supported by a series of principals, made by Messrs. Cockedge, of Stowmarket, and from the centre depend two ventilating sunlight gas-lights, fitted by Messrs. J. H. Pickup and Co., London and Bury. The platform occupies an arched recess 24ft. 6in. across by 9ft. deep, behind which is an organ-chamber, 4ft. 6in. by 11ft., containing an instrument built by Messrs. A. Hunter and Son, of Clapham, S.W. Messrs. Eade and Johns, of Ipswich, were the contractors, and Mr. E. Catchpole, of the same town, was the builder.

**MANCHESTER.**—The Local Government Board have signified their approval of the specifications, plans, and sections for new streets in the Chester-street and Pott-street areas, and the plans of the labourers' dwellings to be erected on those areas. The Board have authorised the city council to carry out their new proposals in regard to the erection of dwellings on the Oldham-road area and a lodging-house for men on the Harrison-street area. In regard to a further loan required for the completion of the rehousing and reconstruction schemes, the total expenditure already incurred and the estimated cost of the works now to be carried out amount to £276,314, towards which the Board have sanctioned loans amounting to £253,375. The amount now required is therefore £22,939, and formal sanction to the borrowing of that sum is now given.

**NEW CROSS.**—New public baths in New Cross-road are approaching completion. The elevation is of red brick and Portland stone, and the buildings are being erected from designs by Mr. Dinwiddy, of Greenwich, and 5, Whitehall, S.W., selected in open competition. A feature of the building is the first-class swimming-bath, with a water area of 110ft. by 35ft., surrounded by a gallery. There is a second-class swimming-bath of somewhat smaller dimensions. There are 69 private baths in four departments, divided into first and second class for men and women. A public washhouse and laundry (containing 23 separate washing cubicles), together with a smaller and separate establishment laundry, are planned at the rear. A well has been sunk to a depth of 250ft., yielding a good supply of water, the quantity being estimated at 40,000 gallons an hour. The total contract sum, including the engines, electric lighting, and well plant, is £37,492.

**SEALAND, CHESTER.**—The foundation-stone of the proposed Infectious Diseases Isolation Hospital at Sealand was laid on Tuesday week by the Mayor. The site forms part of the Sealand estate purchased by the Corporation. The buildings, designed by Mr. H. Beswick, and contracted for by Mr. W. W. Freeman at £14,000, are to be constructed in wire-cut Ruabon bricks with dressings of terracotta. The foundations are to be built on Portland cement concrete footings, and all the ground under the building is to be covered with a bed of Portland cement 6in. thick. The hospital will provide beds for 48 patients, and an administrative block of sufficient size to meet a future extension to 80 patients. It is proposed to provide one isolation pavilion containing four wards of two beds each for undeveloped cases or for paying patients—8; two ward pavilions containing two wards of six beds each—24; one ward pavilion containing one ward for four acute cases and one ward for ten convalescent cases—14. All these buildings will be of one story in height. In order to obtain a south aspect to the wards, the buildings are placed diagonally and in échelon. The space allowed between the ward buildings is 40ft. The administrative block and the laundry blocks are separated from the wards by the main drive, 21ft. wide. The isolated pavilion will be divided by a wall carried through the entire width. Each pair of wards is separated by a nurses' room, with inspection windows into each ward. All doors open out on to a roofed-in verandah. A capacity of 2,000c.ft. is allowed for each patient, and a wall space of 12ft. line for each bed. The wood floors of the wards and nurses' rooms will be of pitch-pine, grooved and tongued, the walls to be plastered and finished in adamant. The administrative block will be a three-story building, with kitchen department one story in height in the rear. The building will be lighted with electricity.

**WESTON-SUPER-MARE.**—The building fund in connection with the proposed new church for the district of All Saints', Weston-super-Mare, has been started, the whole of the £1,310 required for the purchase of the site having been raised before the close of 1897. Mr. G. F. Bodley, A.R.A., has arranged to meet the building committee very shortly, with a view to preparing plans for a new church, the foundation-stone of which it is proposed to lay about Midsummer Day next. The new church will cost at least £6,000; but only the chancel will be proceeded with as a first instalment, and the cost of this will be about £2,000.

## WATER SUPPLY AND SANITARY MATTERS.

**MAIDSTONE.**—The Local Government Board inquiry into the outbreak of typhoid fever at Maidstone was opened on Monday. Mr. Percy Adams, deputy medical officer, said that the inquiries he made after the outbreak led him to believe that it arose from the Farleigh water supply; but he admitted that people had been attacked in streets which did not have water from that source. He did not think the epidemic was caused by the drainage of the town, though it probably accounted for some of the secondary cases. Mr. M. A. Adams, the medical officer, said he considered the organisation for combating with the fever was most complete. The inquiry was adjourned. On Tuesday Mr. Adams, the medical officer of health for the borough, was further examined, and asserted that the state of the drains was certainly not the cause of the outbreak. On Wednesday the evidence of Mr. Adams, medical officer of health, was concluded, and Dr. Washbourn, of Guy's Hospital, and Dr. Sims Woodhead, director of the laboratories of the Royal College of Physicians and Surgeons, were examined.

**THE METROPOLITAN WATER SUPPLY.**—The Royal Commission on this subject sat again on Monday. Sir A. R. Binnie, chief engineer to the London County Council, in cross-examination by Mr. Pope, Q.C., on behalf of the water companies, said that his suggestion was that the undertakings of the water companies should be purchased by a central water authority, preferably by the London County Council; that the existing supply should be maintained as long as might be reasonable; and that any supplemental supply should be drawn, not from the Thames, but from some other source. His idea of a central authority was one upon which the London County Council should be represented to the extent of 80 per cent. The price paid to the water companies should be ascertained, failing agreement, by arbitration under a special clause of an Act to be obtained by the Council. Mr. H. E. Haward, comptroller of the London County Council, was under examination when the commission adjourned. At Tuesday's sitting of the commission, Mr. Haward was further examined. He contended that the water companies' shareholders have received premiums in addition to their dividends, and that the reduction of the water rates of some of them has been unduly postponed in consequence of the creation of unnecessary capital. He supplied statistics in support of these contentions. The witness was still under examination when the commission adjourned.

## CHIPS.

Additions are being made to the Board School, Napier-street, Hoxton, and special consideration has been given to the ventilation, which will be carried out on the Boyle system.

A new tower is about to be added to St. Chad's Church, Chadwell Heath, from designs by Messrs. Chancellor and Son, Chelmsford and London. The work is to be commenced at once by Mr. Joseph Grimes, of North Gate Works, Colchester, who built the church thirteen years ago.

A memorial to the late Mr. Walter Charles Rand, of the Indian Civil Service, who was assassinated at Poona last summer, was unveiled at St. Peter's Church, Lordship-lane, on Saturday afternoon. It is situated at the west end of the church, and consists of a mural tablet of alabaster, with a brass plate bearing an inscription.

A fatal accident happened on the Great Northern Railway at Fletton, near Peterborough, on Wednesday evening. A night-shift gang of men employed at the No. 1 yard of the Peterborough Brick Company were walking up the line, on their way to work, just before six o'clock, when they saw an express approaching. They moved on to the slow road, and had only just got into the four-foot way when they were run into by a light engine engaged in shunting in the brick-yard siding. Four of the men were cut to pieces, and a fifth, Walter Fairchild, was seriously injured. The names of the killed are John Thompson, William Spring, Richard Ripney, and John Woolley. All are single men.

**TO CORRESPONDENTS.**

[We do not hold ourselves responsible for the opinions of our correspondents. All communications should be drawn up as briefly as possible, as there are many claimants upon the space allotted to correspondents.]

7 It is particularly requested that all drawings and all communications respecting illustrations or literary matter should be addressed to the EDITOR of the BUILDING NEWS, 332, Strand, W.C., and not to members of the staff by name. Delay is not unfrequently otherwise caused. All drawings and other communications are sent at contributors' risks, and the Editor will not undertake to pay for, or be liable for, unsought contributions.

Cheques and Post-office Orders to be made payable to THE STRAND NEWSPAPER COMPANY, LIMITED.

**TERMS OF SUBSCRIPTION.**

One Pound per annum (post free) to any part of the United Kingdom; for Canada, Nova Scotia, and the United States, £1 6s. 0d. (or 6dols. 30c. gold). To France or Belgium, £1 6s. 0d. (or 33fr. 30c.) To India, £1 6s. 0d. To any of the Australian Colonies or New Zealand, to the Cape, the West Indies, or Natal, £1 6s. 0d.

**ADVERTISEMENT CHARGES.**

The charge for Competition and Contract Advertisements, Public Companies, and all official advertisements is 1s. per line of Eight words, the first line counting as two, the minimum charge being 5s. for four lines.

The charge for Auctions, Land Sales, and Miscellaneous and Trade Advertisements (except Situation advertisements) is 6d. per line of Eight words (the first line counting as two), the minimum charge being 4s. 6d. for 40 words. Special terms for series of more than six insertions can be ascertained on application to the Publisher.

Front-page Advertisements 2s. per line, and Paragraph Advertisements 1s. per line. No Front-page or Paragraph Advertisement inserted for less than 6s.

Advertisements for the current week must reach the office not later than 3 p.m. on Thursday. Front-page Advertisements and alterations in serial advertisements must reach the office by Tuesday morning to secure insertion.

**SITUATIONS.**

The charge for advertisements for "Situations Vacant" or "Situations Wanted" is ONE SHILLING FOR TWENTY-FOUR WORDS, and SIXPENCE for every eight words after. All Situation Advertisements must be prepaid.

**NOTICE.**

Bound copies of Vol. LXXII. are now ready, and should be ordered early (price Twelve Shillings each), as only a limited number are done up. A few bound volumes of Vols. XXXIX., XL., XLI., XLVI., XLIX., LI., LIII., LVIII., LIX., LXI., LXII., LXIII., LXIV., LXV., LXVI., LXVII., LXVIII., LXIX., LXX., LXXI., LXXII. may still be had, price Twelve Shillings; all the other bound volumes are out of print. Most of the back numbers of former volumes are, however, to be had singly. Subscribers requiring any back numbers to complete volume just ended should order at once, as many of them soon run out of print.

ROLLERS FOR GRANOLITHIC WORK.—A subscriber wants the address of makers of above. Says he has seen an advt. of such in our pages some time, but fails to find it. If makers write to us, we will send him on name and address. We may point out that there is scarcely a week in which we are not thus asked for addresses, and wonder very much that more do not avail themselves of our "Directory," which was intended to give the help thus sought.

RECEIVED.—D. R. and G. R.—F. G.—K. J. and Co.—D. (Ipswich).—F. N. P.

**Correspondence.**

**THE CARDIFF COMPETITION.**

To the Editor of the BUILDING NEWS.

SIR,—As I have failed to get a response from Mr. Waterhouse, I suppose I must now leave the matter to the judgment of the profession, and to the conscience of that gentleman. After that long struggle of three or four months (much of it by "midnight oil"), all we, as competitors, get are: broken conditions of competition; a scant quarter of an hour or so of consideration; and—silence. Surely Mr. Waterhouse's appeal to us to be "up and doing" our best (*vide* his letter to the BUILDING NEWS heralding the competition) promised better treatment from him than we have received. It must be admitted that, of all the unsatisfactory competitions that have taken place, this, the last, will pass down to history as the most unsatisfactory.

An esteemed F.R.I.B.A. has suggested to me that we competitors have a legal claim on the Cardiff Corporation for damages in respect to non-compliance with the conditions. This, however, I leave to other initiative, being more concerned with the moral of this most unfortunate competition.—I am, &c., NEMO.

[We feel ourselves uncomfortably convinced that this competition has somehow miscarried. Mr. Waterhouse is so far above reproach that we should have liked some explanation of the points

raised by "Nemo," which seem to us serious ones, and we think it should have been forthcoming.—ED. B.N.]

**SKETCHES BY CHARLES KEENE.**

SIR,—It will probably interest you to know that the drawing by the late Chas. Keene which was reproduced in your issue of the BUILDING NEWS for Jan. 21, entitled "A Sketch of Turnham Green," is really a view of the Cathedral yard, Exeter, from the "Little Stile," looking eastward. The building in the foreground is occupied by Mr. F. Drake, stained glass artist, that adjoining is still, as it was in Keene's time, a tailor's shop. The view of the church of St. Mary Major is especially interesting as a record, for, since this sketch was made, the fabric has been rebuilt from designs prepared, I think, by the late Mr. Ashworth, architect, of Exeter. In the middle distance appear a portion of the west front and one of the towers of the venerable cathedral, and in the far distance are suggested the houses surrounding the close. The posts in the foreground have been replaced by prim iron railings, and the saplings Keene saw are now mighty trees.—I am, &c., W. T. MARTYN MEAR.

Wadebridge, Cornwall, Jan. 27.

**CHIPS.**

At a well-attended meeting of former scholars at Christ's Hospital School held on Monday, it was decided that a fund should be raised by "Old Blues" to furnish and decorate the chapel of the new school buildings at Horsham. Towards the cost, estimated by the architects, Messrs. Aston Webb and Ingress Bell, at £10,000, £900 was subscribed in the room.

The baptistry at the Holy Name Church, Manchester, was opened on Sunday. It has cost nearly £1,000. The baptistry is placed at the south-west of the church, and is an octagonal building, about 50ft. high. Terracotta tracery has entered largely into its construction and design. It is highly decorated, and the whole treatment, both of the baptistry and the marble font, is on the lines and in harmony with the general style of the church.

The Eyres Trustees are making application to the Court of Chancery for a grant of moneys to be expended in the preservation of the ruins of Dunstanburgh Castle, by pointing and underpinning. The works, if sanctioned, will be carried out under the supervision of Mr. George Reavell, jun., of Alnwick.

An inquest was held at the Royal Albert Hospital, Devonport, on Friday, on Henry Heath Symons, builder, 34 years of age, who died at the hospital two days previously, from the result of injuries to his head. On the previous Friday deceased, who resided at 2, Bridewell-terrace, St. Beaudaux, was in his garden, and was struck by a piece of rock that came from a quarry where blasting was going on. He was conveyed to the Royal Albert Hospital, suffering from a fractured skull. The quarry in question is 77 yards distant from the spot where deceased was struck. The inquest was adjourned until Tuesday, February 8.

The corporation of Carnarvon have been considering ways and means to enable them to give practical effect to the Housing of the Working Classes Act. An important scheme of town improvement is now under consideration, by which a new main thoroughfare will be cut through the worst slum district in Carnarvon, where the sanitary authorities have already condemned a number of houses as unfit for habitation. Colonel Brown, of Chester, has consented to sell an adjoining plot of ground to the municipality for the erection of a number of workmen's model dwellings, and the plans provide for the laying out of three new streets of such model dwellings. The corporation will require to obtain borrowing powers to the extent of £10,000 to carry out the scheme.

An unusually large and varied assortment of properties were offered at the Auction Mart last week, including a tea estate in Assam, a great industrial concern, a suburban building estate, and City and West-end freeholds. The results on the whole were highly satisfactory, although in several cases high reserves proved an obstacle to business. The gross realisation was £238,803—quite a record figure for the first month of the year.

By the General Powers Bill for next session of the London and North-Western Railway Company, power is sought to construct nearly nine miles of new railways in the county of Westmoreland in substitution for the steep gradients at Shap, to widen over two and a half miles in the same county, and also to widen about half a mile of their lines in the city of Manchester. Power is sought to raise £1,500,000 additional ordinary stock, and £500,000 by the issue of debenture stock.

**Intercommunication.**

**QUESTIONS.**

[11887].—Load on Girder.—I should be obliged if one of your able correspondents would give me the formula for ascertaining the load that would be brought

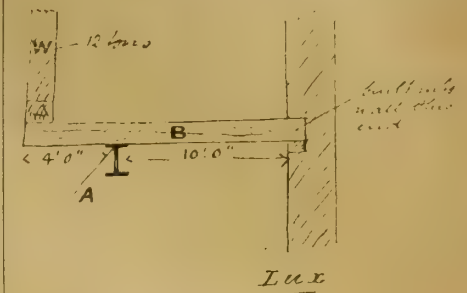

to bear upon the girder A, irrespective of weight on floor, in consequence of the girder B cantilevering over, as shown on sketch, W being the weight at end of girder B.—M. S. R.

[11888].—Light.—I have had built a warehouse, the gable end of which has four windows in (each about 6ft. 6in. by 4ft.), and overlooks land owned by another person. He has now sent me a letter asking for a yearly payment of 5s., as an acknowledgment for the enjoyment of such light. Would some reader acquainted with the right of light question inform me as to how to proceed in the matter? Am I enforced to make a payment at all? MACKENZIE.

[11889].—Protection of Iron.—I should like to be informed if there is any paint or coating for ironwork that can be relied upon? Most of the common paints used peel off the iron. Is there not some new process recently introduced that prevents oxidation?—A. C. D.

[11890].—Cement Tests.—Where can I find records of any recent experiments on Portland cement? Has there been any lately published in the "B.N."? I shall be glad with the date.—G

[11891].—Payments under Contract.—Will some practical reader tell me what is the usual percentage of payment made on goods delivered on site and the time at which they are made from date of delivery? The goods are castings of columns, caps and bases, &c. Also when the remaining percentage ought to be paid? The usual condition as to these points would be of service.—INEXPERIENCED.

[11892].—Ventilators.—Which of those in the market have the largest extracting power? If we can extract the foul air fast enough, the fresh air is bound to follow. Draughts can be discounted by properly devised inlets. I should like some information.—PERPLEXED.

[11893].—Artificial Stone.—I have been told that there is a kind of stone manufactured which is much more durable than Portland stone, and is well suited for window-sills, copings, cemetery monuments, &c. If any of your readers will kindly give me any information as to the same I shall feel obliged, also the price in London?—A. M.

[11894].—Fire-Grate.—Can any of your readers tell me of a good grate, with warm-air chamber fed by inlet from outside, and provided with means of warming the room above? There are plenty in the market; but they are of the ordinary construction.—S.

[11895].—Norwegian Houses.—Can any reader tell me where I could obtain information regarding the construction of Norwegian timber houses?—DESIGNER.

[11896].—French Gothic Architecture.—Where can I obtain information about the classification of French Gothic, corresponding to our own division into styles, and what are the best books to consult? The distinguishing features and mouldings are, of course, important.—S. T. W.

**REPLIES.**

[11884].—"Red" and "Yellow" Deal.—I am obliged to "A. H." for his concise reply to my query; but still the terms are misleading to the trade, whether builders, carpenters, or joiners. Mr. Stevenson's remarks the other day confirm "A. H." and I am glad to be reminded of the work he mentions. These are the technical points a student looks in vain for in the ordinary hand-book.—A LEARNER.

[11886].—Board of Trade Appointments.—Apply by letter to the Secretary of this department.—G. H.

Mr. Norman R. Wilson has been appointed assistant surveyor to the North Riding County Council.

Herr Rudolf Alt, the leading water-colour painter in Austria, has been knighted by the Emperor. The new knight is eighty-six years old, and, being too feeble to work, lives on a pension of one thousand florins a year, granted him last year by the town of Vienna. He painted by preference architectural subjects, mostly the interior or exterior of Gothic churches, and in this line he has no living rival. He has executed several hundred architectural water-colour drawings, each of which commands thousands of florins when on the market, but he has remained poor throughout. His younger brother, Franz Alt, aged seventy-seven, is also a celebrated water-colour artist, his speciality being landscape.

## LEGAL INTELLIGENCE.

**CURIOUS DISPUTE BETWEEN BUILDER AND BUILDING OWNER.**—The case of Seager v. Wigglesworth came before Mr. Justice Darling at the Kent Winter Assizes on Saturday, and was an action brought by Mr. Laurence Seager, builder and contractor, of Sittingbourne and Sheerness, to recover £156 17s. 6d. damages for breach of contract and expenses incurred thereby, against Mrs. Charlotte Wigglesworth, a lady of independent means, residing at Queenborough. In March, 1896, defendant asked plaintiff to build four houses for her in Queenborough. While these houses were in course of erection, defendant approached plaintiff's manager with a view to plaintiff building her nine more houses and a shop. Plaintiff in consequence had interviews with defendant on the subject. He visited her at Queenborough, and plans were drawn up. To these the lady would not agree, and eventually she said she would have the new houses built on the same plan as the previous four. On the 20th of May a decisive conversation took place, when plaintiff went down to Queenborough, faking with him the plans for the nine houses and shop. The price agreed on was £1,325. For various reasons plaintiff did not commence building the houses for some time afterwards, but eventually he did start. The ground was stumped out, the site cleared, and scaffolding erected; but a misunderstanding occurred between the contracting parties, with reference to the first four cottages, and defendant lost her temper. She told plaintiff to stop the building, and remove all his articles from the building site. Considerable correspondence passed between defendant's solicitor and plaintiff, and eventually plaintiff agreed to remove his scaffolding, &c., from the ground, but when he sent down appliances to do this he was stopped by defendant. Some of his goods he had removed, but the scaffolding was left, worth about £33, and the defendant now told plaintiff that he could have this if he paid her £8 17s. 6d. for cartage and storage. There the matter rested. For the defence it was emphatically stated that no contract was entered into, and that plaintiff was told on various occasions in May, June, July, and finally in August, by defendant, that she would not enter into contract with him, looking at the delay which had occurred in the building of the previous four cottages, the time for carrying out their erection being lengthened to twice the period agreed upon. Defendant was willing to pay £7 7s., which it was agreed was a fair price as remuneration for getting out the plans which were sent to the Queenborough Town Council for approval. His Lordship having summed up, the jury found that no contract had been entered into; that £10 10s. was a fair sum for the drawing up of the plans for presentation to the town council, and that the goods belonging to the plaintiff were not wrongfully detained. With regard to the counterclaim for the carting and storage of the plaintiff's goods by the defendant, the jury awarded Mrs. Wigglesworth £10 10s. Judgment was entered for plaintiff for £10 10s. on the claim, and for defendant for a similar amount on the counterclaim, and plaintiff was ordered to pay the costs.

**ARBITRATION CASE AT RHYL.**—Mr. Baldwin Latham, C.E., concluded on Friday his arbitration at Rhyll with respect to a claim of £3,500, made by Mr. Jacob Biggs against the Rhyll Urban District Council for extras and for damages for delays in connection with the carrying out of the new sewerage works at Rhyll, of which he was the contractor. The council counterclaimed against Mr. Biggs the sum of £3,507, for penalties and for non-completion of the contract within the specified time. The arbitrator will make his award in due course.

**THE PURCHASE OF HARROGATE WATERWORKS.**—On Saturday, at the Westminster Palace Hotel, an arbitration involving a sum of between £180,000 and £240,000 was brought to a termination. It was a case in which the corporation of Harrogate are acquiring, under an Act of last Session, the undertaking of the local Waterworks Company. Mr. Shirell Will, Q.C., sat as umpire, with Mr. J. Mansergh and Mr. Fenwick as arbitrators, the former for the corporation and the latter for the company. It appeared that the company was formed in 1846, and that its share capital stood at £76,000 and the loan capital at £19,000. It paid no dividend till 1857, when some interest was paid on the 10 per cent. stock; in 1884 full dividends on all classes of stock were paid; and after a while so much profit was earned that the arrears of dividend were cleared off, this operation being completed a year ago. So sound was the position of the company that between 1886 and 1896 the net profits increased from £4,450 to £3,790. The company's valuers assessed the maximum dividend payable at 36·36 years' purchase, taking the ordinary stock to be of equal value to that of the preference. Some 4½ per cent. debenture stock they capitalised at 40 years' purchase. The total of the company's valuation was about £220,727, on which the usual allowance of 10 per cent. for compulsory sale was put, making £242,800. For the corporation it was stated that the proper basis to test waterworks was to take

their capacity over a period of three dry years, such as 1887, 1888, and 1889. On that basis it was held that the available quantity would be insufficient for the requirements of the town, and the already large consumption was likely to increase by the further use of baths and lavatories. The valuations of the corporation witnesses ranged from £170,000 to over £180,000. Expert witnesses stated that in case of another very dry year they should anticipate a water famine. Eventually the umpire reserved his award.

**IN RE JOSEPH WHALE, BUILDER, PORTHILL, BURSLEM.**—At Hanley, on Friday, the public examination of this debtor was held. The debtor's statement showed gross liabilities £7,287 1s. 7d., of which £1,266 2s. 2d. was expected to rank. The assets were estimated to produce £633 4s. 11d., leaving a deficiency of £582 17s. 3d. The debtor attributed his failure to losses on various properties. In answer to Mr. T. Bullock (official receiver), the debtor said that since 1894 he had been engaged as a speculative builder, having previously worked as a foreman builder for Colonel Chambers, of Eccleshall. He commenced building with a capital of £150, and during the last two years he had erected about 46 houses. He borrowed money from various societies on security of the properties, and had an overdraft at the bank. He had suffered losses through untenanted houses, through law costs, and through auction expenses. The examination was adjourned, the debtor being ordered to file a cash account from January, 1895.

**APPEAL UNDER THE PUBLIC HEALTH ACT.**—E. WOOD V. THE MAYOR AND CORPORATION OF WIDNES. —The Court of Appeal, composed of the Lord Chancellor and Lords Justices A. L. Smith and Collins, had before them on Friday this appeal of the respondents from the judgment of a divisional court (Mr. Justice Lawrence and Mr. Justice Ridley), holding that the plaintiff was not liable, under the Public Health Act, to pay for private improvements carried out on his behalf by the mayor and corporation, the sanitary authority for the borough of Widnes. It appeared that Mr. Wood was the owner of Nos. 52 to 63, Terrace-road, Widnes; and on the 22nd March, 1895, the sanitary inspector served notice upon him, stating that there was a nuisance at the houses referred to, and requiring the erection of water-closets. Non-compliance with the usual notices having been reported to the corporation, their officers did the work, and summoned Mr. Wood to recover for the "private improvement" made, the first instalment of the cost—namely, £6 8s. The magistrates made an order for payment of this sum, with 9s. 6d. costs. The divisional court held that the resolution passed by the corporation requiring the work to be done was not valid, and set aside the order of the justices. Hence this appeal of the corporation. The Lord Chancellor, in giving judgment, said there was no doubt that the notice given to the appellant in this case was quite sufficient as indicating the houses alluded to. But the notice went farther, and stated that a certain system of closet must be provided, and that was going beyond the powers of the local sanitary authority. The effect of the order was that unless a certain system was adopted there would be no compliance with the requirements of the corporation. It was not merely an intimation to the owner of the house property as to how the work should be done; it was part of the order itself, and therefore it was impossible to contend that this was a sufficient compliance with the statute. Therefore the appeal would be dismissed, with costs. Lord Justice Smith said he quite agreed with the Divisional Court in holding that the notice was bad in law, and Lord Justice Collins concurred, and for the reasons already expressed.

**PARTY-WALLS AND FOOTINGS UNDER THE LONDON BUILDING ACT.**—THORNTON V. HUNTER.—In the Chancery Court last week Mr. Justice Romer heard this case from Clapham, in which the plaintiffs were Percy Thornton, M.P., and five others—namely, John Harris Tyers, Charles William Munslow, Frank S. Harnett, Thomas Ravenhill, and Charles Farley Trenerry, leaseholder of the premises, 63, High-street, Clapham. The defendants were Alfred Hunter, organ builder, of 65, High-street, Clapham, and Henry Somerford and Son, builders, of 133, Manor-street, Clapham. Proceedings arose on a claim made by the plaintiffs for an injunction to restrain the defendants from erecting, or allowing to remain erected, any wall or any footing upon the land of the plaintiffs known as No. 63, High-street, Clapham, and for damages sustained by them. The defendants contended that the London Building Act of 1894 gave them the right in the circumstances to place footings upon plaintiff's land for the purpose of rebuilding or building a new wall. The pulling down of a portion of the house, No. 63, resulted in the falling of the southern flank wall of the said house, which in its fall damaged the northern flank wall of the house, No. 65, High-street, Clapham, occupied for many years by Mr. William Baldwin, proprietor of the *Clapham Observer*. The plaintiffs called Professor Banister Fletcher, F.R.I.B.A., who had made a personal examination of the premises. He gave evidence that he saw the

hole in the side wall of No. 65, caused by the falling down of the wall of No. 63 on Sunday evening, November 8th, 1896. The plaintiffs' wall and defendants' wall formed a party-wall, belonging to the joint parties—one-half to each. Defendants' counsel here claimed that the whole of the wall was built on their property. Witness continued that the wall was distinctly of a party character by requirement, and also under the Act. In the lower portion there were two walls about equal thicknesses, bonded together so far as the portion visible could be examined. Mr. Wilfred John Hardcastle, architect, and district surveyor for the central division of Battersea, agreed generally with Mr. Fletcher as to the inference of the age of the house. He went round to inspect, to see whether the wall appeared to be a party-wall, or two external walls, and he came to the conclusion that it was not a building inclosure. To the defendants' house there was not sufficient wall to protect from plaintiffs' house in certain circumstances. The 4½ in. wall existent at defendant's house was not a sufficient inclosure. It could not have stood. It was a structure consisting of many pieces of wall put together, a piece of patchwork, with no distinct bonding. Charles Holland, foreman to Mr. Haydon, builder, of Hackney-road, said he was in charge of the workmen employed to clear the site of No. 63, High-street. He did not notice any mortar between the two walls. He pulled down the wall which abutted on the plaintiffs' house. He left it on Saturday afternoon, and then it was all right. It was all standing then perfectly, as high as defendants' wall. He left it standing shored up against the defendants' premises. The walls were not bonded together in any way. It did not fall down, it "blowed" down. Defendants' counsel then read numerous letters which passed between the solicitors, also particulars of a similar case, "Knight v. Perceval," and the Judge said that it was quite clear that if you had two external walls you do not make them a party-wall, even if they touched. It was a question whether by usage they became a party-wall. Mr. W. Baldwin, tenant of the premises, 65, High-street, Clapham, then gave evidence of the fall of the wall on Sunday night, Nov. 8, and of the damage thereby occasioned. The witness showed to the satisfaction of the learned judge that the walls were perfectly distinct, a cupboard on his own premises designed by the architect having its own brickwork at the back. Evidence was also given by Mr. Walter Henry Woodroff as to the measurement of the premises, and the walls, also by Mr. Alfred Conder, F.S.I., district surveyor, who accompanied Mr. Woodroff when he measured the premises. In summing up, the Judge said that he found as a fact that plaintiffs and defendants had each an external wall built on their own premises respectively. As a matter of fact, the defendants had an external wall on the defendants' own land, though they had committed a trespass in placing footings and foundations upon plaintiffs' land; that plaintiffs were at liberty to remove them; and he awarded damages £15, including costs of removal of said footings. He added that in the main point defendants were right, and he gave defendants general costs of the action, except so far as those costs had been increased by the question as to the footings. On the suggestion of the learned judge, defendants withdrew their counterclaim for damages to their house caused by the falling of the wall. The plaintiffs desired the erection of the party-wall in place of the two walls, whereas the defendants had erected an independent wall as a structure to repair the house. The Judge held that the defendants were right in the main, in the defence of the action; but he further held that the London Building Act did not give the defendants a right to put their footings upon the plaintiffs' land.

The Leicester Town Council have decided to raise the salary of their town clerk from £1,000 to £1,250 a year.

Mr. E. J. Hughes, the surveyor to the Newhaven Urban District Council, has tendered his resignation to that body after 14 years' service.

The Princess Christian visited Chatham on Wednesday, and laid the foundation-stone of the new town-hall in course of erection from plans by Mr. G. E. Bond, M.S.A., of High-street, Rochester, at a cost of about £30,000, and also formally opened the Victoria Tower, which has been added to the parish church, under the direction of Sir Arthur W. Blomfield, A.R.A. The tower has cost £3,300, and contains a peal of eight bells, cast by Messrs. John Warner and Sons. It is proposed to rebuild the nave of the church as early as possible.

In the Plymouth Guildhall on Monday evening a meeting of the townspeople was asked to express approval of the proposal of the corporation to apply to Parliament for a Bill in connection with the expenditure of £669,000, chiefly in connection with improving the Cattedwater. By an overwhelming majority the meeting approved of the town council's action. A poll was, however, demanded.

## Our Office Table.

THE elections to the three remaining vacancies at the Royal Academy, for the choice of two Academicians and one Associate, took place on Wednesday evening, and aroused much curiosity and interest in artistic circles. Fifty-one Academicians and Associates met at the sculpture gallery of Burlington House, an unusually large muster. As had been generally anticipated, the vacancies in the ranks of Academicians were filled by Mr. B. Williams Leader, the landscapist, and Mr. Seymour Lucas, the historical and portrait painter. Mr. Leader, who is 67 years of age, is brother to Sir E. Leader Williams, the engineer of the Manchester Ship Canal; his fellow Academician, Mr. Lucas, is 49. The voting list for the Associateship contained the names of about 160 painters, architects, and sculptors. In the preliminary ballot, Mr. Alfred East headed the list with 9 votes, Mr. Joseph Farquharson received 7, Mr. Napier Hemy and Sir George Reid, P.R.S.A., 6 each, and Mr. John Belcher, F.R.I.B.A., Mr. Aston Webb, F.R.I.B.A., and Mr. A. S. Cope 4 each. In the next ballot 10 votes were given to Mr. East, 9 to Mr. Napier Hemy, 7 to Mr. Farquharson, 6 to Sir George Reid, and 5 each to Messrs. Cope and Corbett. In the end, Mr. Napier Hemy defeated Mr. Alfred East by the narrow majority of two votes—26 to 24. Mr. Napier Hemy, the new A.R.A., who lives and works at Falmouth, is widely known as a painter of sea and ships; his picture "Pilchards," was purchased by the Chantry Trustees, from last year's exhibition at the Royal Academy, and now hangs at the Tate Gallery.

It is stated that Mr. Aston Webb's designs, selected more than half a dozen years ago in the competition for the reconstruction of South Kensington Museum, have at last been adopted by the Government, although in a modified form. It is now proposed by the Treasury that a sum of £400,000 shall be expended upon the works, to be spread over a period of ten years. We illustrated Mr. Aston Webb's designs in our issues of August 7 and 14, September 11, and November 20, 1891.

THE annual dinner of the architectural staff of H.M. Office of Works, 15, Whitehall-place, was held on Wednesday, January 26th, at the Commodore's Salon, Holborn Restaurant. The chairman, Mr. Henry Tanner, F.R.I.B.A., was supported by Mr. W. T. Oldrieve. The toast of the "Queen" having been drunk, a musical programme was gone through, the performers being members of the staff. The songs by Messrs. Reavell, Hault, and Neubronner, and the violin solos by Mr. H. B. Creswell were especially applauded. The toast of the "Chairman," proposed by Mr. W. J. H. Leverton in a witty speech, was enthusiastically received; Mr. Tanner's reply meeting with a similar reception. The toast of "Mr. Oldrieve and the Dinner Committee," proposed by Mr. Reavell, concluded the list.

THE London County Council have under consideration some alterations in the conditions of building contracts, and recently forwarded the new draft form to the London Institute of Builders for their observation. In returning the draft, Mr. R. S. Henshaw, the secretary of the Institute, states that his council "acknowledge that the proposed modifications are satisfactory so far as they go, though they leave the conditions still very onerous and stringent. The proposed arbitration clause would be more acceptable if modifications were made in several of the other clauses. . . . The contract form might be much more concise, and there is in it so much that gives a possibility of petty disputes that it is doubtful whether builders who can find sufficient work in other directions will trouble to compete under such conditions. The Council would be much better served were they only to invite selected builders, and adopt a simple form of contract. . . . The whole of the stipulations in regard to securing that contractors shall pay the standard rate of wages and observe the customary hours of working is altogether unnecessary, as it would be quite impossible for a contractor to carry on his business unless he conformed to the agreements in all these respects."

At the quarterly meeting of the Glasgow Master Wrights' Association in the Building Trades Exchange, Gordon-street, Glasgow, on Friday night Mr. Ninian Macwhannell, architect,

delivered an address on "The Modern Tenement—Constructive and Artistic." He submitted a number of plans of buildings recently erected in Glasgow, which he criticised, and stated that the first consideration in planning was the comfort and health of the incoming tenants, and that could only be secured by seeing that light and air penetrated every corner of the house. Dark recesses meant dirt, and it might safely be assumed that where light did not penetrate air did not circulate. There must be no stagnation of air. Every house should be so planned as to facilitate a change of air. He classified the modern tenement under two distinct plans—the internal staircase plan and the balcony plan—and favoured the internal staircase plan, because the balcony, projecting as it did 4ft. from the building, interfered with the light (this was not noticeable if the windows faced the north); it also interfered with the circulation of air. Balconies did not give the same amount of privacy that was afforded by the internal staircase. The planning of single-apartment houses in the same tenement with room and kitchen houses was to be commended and encouraged. Every house, not including the single-apartment house, should have its own water-closet; the system of providing one w.c. for two or four houses in new tenements was condemned. All gas-pipes should be exposed, and iron substituted for the usual block tin. Better glass might be adopted to glaze windows, as the amount of light was considerably modified by the quality of the glass. The tenement of to-day was well built, and for this Glasgow was indebted to the Buildings Regulations Act, and to the Master of Works Department. Speaking of cost, he pointed out that the tenements of room and kitchen houses built on the balcony plan for the Improvement Trust were about £40 per foot of frontage, as against £35 for those built by the speculative builder. The two-room and kitchen house, with scullery and bath-room, cost about £45 per foot of frontage. All over, tenements might safely be estimated at from 4½d. to 5d. per cubic foot.

THE Marquis of Bute has for some time past been reconstructing the old castle wall at Cardiff, from a point at the rear of Duke-street, for a distance of 100 yards parallel with the North-road. The wall has now been erected to within 30 yards of the corner, at which it will meet the other and older wall at right angles. A large multangular tower will be erected at the N.E. angle at which the walls will meet. For centuries the earth at this corner has sloped upward from the canal bank to a height of about 30ft. The excavations of the past few days have brought to light the fact that in the very heart of the earthwork there has laid buried for many centuries what appears to be the rubble foundation of an angle tower of undoubted Roman origin. Writing in his work upon Medieval military architecture in 1884, the late Mr. G. T. Clark expressed his opinion that the castle is of Roman origin, but said that his "opinion is but moderately supported by scanty discoveries of Roman remains." This supposition is now amply confirmed.

THE excavations which are being made in connection with the rebuilding of the premises of Messrs. Berrill, in the Minories, at Birmingham, have once more revealed a portion of the foundation of the Priory of St. Thomas. The foundations were discovered on the occasion of alterations made a few years ago. They were the foundation-stones of an irregular wall, but what part of the original priory could not be determined, although from the discovery of the skeleton of a female within the wall it was presumably the wall of the chapel dedicated to the Blessed Mary. Interest was aroused by this discovery, and, by the care of the architect and builder, Mr. William Jenkins and Mr. Twigg, the remaining stones were again buried. They have not had much rest, for the building is now being finally removed preparatory to the entire re-erection of the whole block—a proceeding which necessarily will entirely remove the last possible vestige of the priory. The date of the priory foundation was about 1280; but the chapel was probably enlarged or rebuilt by Fulk Byrmingham about 1340. The whole was surrounded by the burial-place or cemetery by the fraternity, the Augustinian Friars. In 1547 the friars and their prior were removed, and the Crown seized upon the whole estate, including the chapel. The reappearance of the foundation-stones of the priory has been looked for with some interest, and, by the direction of the archi-

itects, Messrs. Essex, Nicol, and Goodman, every care has been taken by the foreman and clerk of the works in having the ground reopened. Some of the stones give evidence of having been previously used, several of them having the colouring and whitened sides still preserved, and traces of colour still perceptible.

THE Cheshire County Council have adopted a plan prepared by Mr. H. Beswick, the county surveyor, for dealing with the law and old prison buildings of Chester Castle. A portion of the site will be handed over to the corporation of Chester free of charge, on condition that the corporation construct a new public carriage drive through this land, with grass verge on each side and one footpath; the grass verge on each side of the road to be planted with trees, and the space between the drive and the city walls to be fenced in and planted with ornamental trees and shrubs. The corporation are also to cut through the city walls and construct a bridge at least 25ft. span and 15ft. high at their own expense, and to continue the carriage drive across that part of the Little Roodee belonging to the county, and connect this drive with that now being made by the corporation across their part of the Little Roodee to the Grosvenor-road. The remainder of the land will be resold by the council for the erection of houses of £25 to £30 annual rental, to be erected to designs in harmony with the county buildings, and to be approved by the county. The land contains about 3,200 square yards.

THE London County Council discussed on Tuesday at great length two subjects, adjourning the debate in each case. The first related to a scheme to be laid before the Royal Commission for the taxation of site values in the County of London. The second referred to a project propounded by the Fire Brigade Committee for such an extension of the brigade as will secure the better protection of London from fire. Most of the recommendations of the committee were adopted unanimously. They included a large increase in the number of stations and appliances for the extinction of fires and of 61 in the number of men employed, the estimated capital outlay being £197,000 and the increased annual expenditure on maintenance being £26,000. It was stated that the new works would occupy 10 years for their execution, and that the cost for the first year would be equal to a rate of about one-third of a penny in the pound.

THE Carpenters' Company hold three courses of lectures in their hall during the year, and are issuing the programme of that series which appeals to a larger and more general audience than the highly technical courses given in the early summer and autumn. These lectures, which begin on February 21st, and are, of course, more especially addressed to those engaged in architecture and building, will be fully illustrated by experiments and lantern slides. The names of the lecturers are so well known that they require no comment from us. They are Professors Silvanus Thompson, Banister Fletcher, and T. Roger Smith, Mr. Lewis F. Day, and Dr. Longstaff. Sir John Lubbock and Sir Arthur Blomfield are among the gentlemen who have promised to preside. The subjects, &c., will be announced in our advertisement columns next week.

THE work sent in for competition at the annual exhibition of the Border Counties Master Painters' Association, which opened at Galashiels on Saturday, was judged on the previous day in the Burns Hall, Galashiels, by Mr. C. Charlton and Mr. R. J. Bennett, Glasgow. The judges state that they found a marked improvement in the work from former years. The apprentices' work was very good, the writing and decorative panels being excellent in drawing, execution, and colour. The following were the first prize winners in the respective classes:—Apprentices: First year, C. F. Howieson, Hawick; second year, James Macintosh, Galashiels; third year, James Hill, Hawick; fourth year, Robert Revilly, Galashiels; fifth year, Ebenezer Vannan, Galashiels; sixth year, James Hill, Hawick. A special prize of a silver medal for the best panel was won by James Hill, Hawick. Journeyman's Class: Robert Douglas, A. D. Clark, and Phil Dodds, Galashiels; and C. F. Howieson, Hawick.

The fifteenth annual dinner of the Clerks of Works' Association will take place at the King's Hall, (Holborn Restaurant, on Monday week, the 14th inst. Mr. W. Howard Seth-Smith, F.R.I.B.A., will occupy the chair.

MEETINGS FOR THE ENSUING WEEK.

SATURDAY (TO-MORROW). — Architectural Association. First Spring Visit to Five Houses near Park-lane, W. Meet at Lord Ribblesdale's House, corner of Norfolk-street and Green-street. 2.30 p.m.
MONDAY. — Royal Institute of British Architects. "Housing of the Drama," by E. O. Sachs. 8 p.m.
Society of Arts. "Decorative Woodwork." Cantor Lecture No. 3, by Cyril Davenport. 8 p.m.
Society of Engineers. 7.30 p.m.
Liverpool Architectural Association. "The Quality of Strength in Architecture," by W. H. Bidlake, F.R.I.B.A. 8 p.m.
Surveyors' Institution. Adjourned discussion on "Technical Tribunals and Surveyors as Arbitrators." 8 p.m.
TUESDAY. — Institution of Civil Engineers. 8 p.m.
Leeds and Yorkshire Architectural Society. "Early Renaissance Sculpture in Tuscany," by W. H. Thorp, F.R.I.B.A.
WEDNESDAY. — Surveyors' Institution. Annual Dinner at the King's Hall, Holborn Restaurant. 6.30 p.m.
Society of Arts. "Compensation to Workmen," by A. D. Proband, M.P. 8 p.m.
Edinburgh Architectural Association. "The Vernacular of the Wren School," by J. A. Williamson, A.R.I.B.A. 8 p.m.
THURSDAY. — Royal Institution. "Some Italian Pictures at the National Gallery" (first of three lectures), by Dr. Jean Paul Richter.

CHIPS.

The treasurer of Guy's Hospital has received from Mr. Henry Lewis Raphael the sum of £20,000, to be devoted to the building of the "Henriette Raphael Nurses' Home," in memory of the late Mrs. Raphael.

A reredos of polished oak and a font have been placed in Great Baddow parish church as memorials of the late Mrs. Finch.

The work of renovating the organ of St. George's Hall, Liverpool, is now almost finished, and the instrument is to be reopened next week. Mr. Henry Willis, the builder of the instrument, has superintended the present alterations.

Mrs. William Bell Scott, widow of the well-known architect, painter, etcher, poet, and critic, the friend of Carlyle and Ruskin, has just died in Chelsea. She had reached an advanced age.

The Corporation of Leamington are about to build a technical institute and free library, at an estimated cost of £14,000, exclusive of site.

The plans for the arrangement of the town's yard, prepared by the borough surveyor (Mr. J. Ainsworth Settle, A.M.I.C.E.), have been adopted by the town council of Heywood. The fire-station is to face Hind Hill-street, and adjoining will be the firemen's dwellings, a dozen in number. Behind the fire-station there will be stables for the horses of the brigade, and also stables for 16 horses for the health and surveyor's department. Masons' sheds, store-rooms, &c., will likewise be built.

Mr. Walter A. Ducat, an inspector under the Local Government Board, held an inquiry on Friday in reference to an application of the Swinton and Pendlebury Urban District Council to borrow £26,155 for works of sewage disposal, and for private and public street improvements.

After a long discussion on Friday the General Purposes Committee of the Blackpool Corporation sanctioned the expenditure of £40,000 upon the extension of the electricity works.

Mr. T. H. Nesbitt, town clerk of Douglas, Isle of Man, has been appointed vestry clerk of St. George's, Hanover-square, London, in succession to the late Mr. Smith, at a salary of £600. There were seventy-two applicants.

A large discovery of old English coins was made on Saturday at Penicuik, near Edinburgh, and the Crown authorities are taking precautions that the collection be preserved in toto. So far 270 coins of the period of Edward I. have been unearthed. The coins were in rouleaux. The greater number consist of silver pennies and half-pennies minted between 1272 and 1307. The majority bear the London impress, Canterbury comes second, while the Bristol, Newcastle, and Durham marks also occur. A few bear the stamp of the Dublin Mint. Two of the coins are of Alexander III.

The new organ which Messrs. Hele and Co., of Plymouth, have built for use at the Bishopston Wesleyan Chapel, Bristol, was opened on Sunday.

The first sod was cut at Llandudno on Tuesday for the erection of extensive convalescent homes, in accordance with the will of the late Lady Forrester. The site is about a mile east of the town, commands charming views, and the buildings are to cost £50,000.

Trade News.

WAGES MOVEMENTS.

BELFAST.—Notices, terminable in three months, were served on Tuesday upon the Belfast building trade employers on behalf of the local carpenters and joiners, bricklayers, plasterers, and stonecutters, for an advance of wages and the cessation of work on Saturdays at 12 o'clock. The bricklayers, joiners, and plasterers ask for a halfpenny per hour increase, and the stonecutters three farthings. About 8,000 men are involved in the demand. Employes contend that the trade is extra good just now.

Schemes are afloat for extensive building operations at Tuxford, the opening of the new railway having created a great demand for dwellings. The Great Northern Company have acquired land adjacent to their station, where forty houses are to be erected. A private company has purchased the St. John's College site, on the Eglington-road, close to the L. D. and E. C. station, where two rows of houses will be put up. The L. D. and E. C. Railway Company will erect houses for their staff on two sites of the Duke of Newcastle's land on the east side of the Great North-road, on a point where the new railway crosses the Newark-road.

The Muir Hall of Residence in George-square, associated with the University of Edinburgh, was opened by the Duchess of Buccleuch. It is intended to rent the bedrooms to the lady students. The alterations required to adapt the building to its new use have been extensive, and include the addition of two new stories and the entire remodelling of the interior. On the upper floors sleeping accommodation is provided for twenty-three students and the lady superintendent, while the ground floor is given up to a dining-hall to the back, and a drawing-room to the front. The kitchen and servants' bedrooms are placed in the basement. The architects are Messrs. Dunn and Findlay, of Edinburgh.



BILLS OF QUANTITIES, PLANS, &c. Lithographed in best style and with great expedition by PARTRIDGE & COOPER, ARCHITECTS' AND SURVEYORS' LITHOGRAPHERS, 191 & 192, Fleet St., and 1 & 2, Chancery Lane, London, E.C. Special Prices quoted for Large Jobs. LIBERAL DISCOUNTS ACCORDING TO ARRANGEMENT.

PILKINGTON & CO. (ESTABLISHED 1838), MONUMENT CHAMBERS, KING WILLIAM STREET, LONDON, E.C.

Registered Trade Mark: POLONCEAU ASPHALTE

Patent Asphalte and Felt Roofing. ACID-RESISTING ASPHALTE. WHITE SILICA PAVING. SEYSSSEL ASPHALTE.

FAMBRINI & DANIELS, MANUFACTURERS OF IMPERISHABLE CONCRETE MASONRY FOR CORNICES, STRING-COURSES, MODELLED PANELS, AND EVERY STONE-WORK REQUISITE. LANDINGS and Plain or Moulded and Mitre STEPS, durable throughout. WORKS AND OFFICES: LINCOLN.

HAM HILL STONE. DOULTING STONE. THE HAM HILL & DOULTING STONE CO. Incorporating THE HAM HILL STONE CO. and C. TRASK and SONS (THE DOULTING STONE CO.) Chief Office: NORTON, STOKE-UNDER-HAM, SOMERSET. London Agent: Mr. E. A. WILLIAMS, 16, CRAVEN STREET, STRAND.

LATEST PRICES.

Table with multiple columns listing prices for IRON, &c., TIMBER, and OILS. Includes items like Rolled-Iron Joists, Cast-Iron Columns, Sheet Zinc, Teak, and various oils with their respective prices per ton or per load.



LIST OF COMPETITIONS OPEN.

Kastleigh—Public Offices	50gs. (merged), 20gs.	Hy. White, Clerk, U.D.C., 19, St. Peter's-street, Winchester	Feb. 7
Wolverhampton Motor Vans	Public Works Committee	J. W. Bradley, C.E., Borough Engineer, Town Hall, Wolverhampton	" 7
Tullamore—Houses for Working Class		C. Quirke, Town Clerk, Tullamore	" 7
Barrow-in-Furness—Technical Schools	£50 (merged), £20	The Town Clerk, Town Hall, Barrow-in-Furness	" 14
Port Elizabeth—Free Library (Assessors, Sir F. Blaine and R. H. Hammersley-Hunan—£22,000 limit)	100 Guineas, 50 Guineas	G. Oettle, Librarian, Port Elizabeth, S.A.	" 15
Winchester—Public Baths	£25, £15	Walter Bailey, Town Clerk, Guildhall, Winchester	" 23
New York—Sun Dial (Plaster Model)	500dol., 250dol.	Sec. National Sculpture Soc., 215, West 57th-street, New York	" 23
Newcastle-on-Tyne—New Infirmary (local Architects)	(No first) £150, £100, £50	Secretary Building Committee, Newcastle	Mar. 1
Berwick-on-Tweed—Police-Station (£5,000 limit)	Commission or £50, £25	R. Weddell, Town Clerk, Berwick-on-Tweed	" 14
Belper—Sewage Disposal Schemes	50 Guineas, 25 Guineas	Joseph Pym, Clerk, Belper	May 1
Stockholm—City Railway Stations and Junctions	£656, £438, £219	Consulate General, 27, Great Winchester-street, E.C.	Aug. 31
West Bangour, Linlithgowshire—Lunatic Asylum (limited to Scotch Architects)	£250, £200, £150, £100	Secretary, District Lunacy Board	—
Southampton—Fireproof Flooring, Warming, &c., Municipal Lodging Houses	10 Guineas	W. B. G. Bennett, Borough Surveyor, Southampton	—
Royal Aquarium—Design for Poster		Edgar S. Shrubsole, Royal Aquarium, London	—

LIST OF TENDERS OPEN.

BUILDINGS.

Port Talbot—Schools for 800 Children	Margam School Board	Frank B. Smith, Architect, Port Talbot	Feb. 5
Pontefract—Alterations, Conservative Club	Guardians of Atcham Union	Greaves and Sidebottom, Architects, Ropergate, Pontefract	" 5
Cross Houses—Wards and Porter's Lodge at Workhouse		J. R. Withers, Architect, St. Mary's-court, Shrewsbury	" 5
Raphoe—Teachers' Residence		P. Gillespie, Schoolmaster, Raphoe	" 5
Earlestown—Premises, Crow-lane	Industrial Co-operative Society	P. M. Beesley, Architect, 2, Bridge-street, Earlestown	" 5
Darfield—Four Houses		Jno. Robinson, Wombwell	" 5
South Shields—Rebuilding Britannia Hotel	Rowell and Son	J. Wardle Donald, A.R.I.B.A., South Shields	" 5
Broadley—Vicarage		T. H. Farrar, Architect, Fountain Chambers, Halifax	" 5
Crawcrook—Shop, House, and Cottage	Thos. Pattinson	Michael Westgarth, 1, Barmoor-terrace, Ryton-on-Tyne	" 5
Marykirk—Napier School		Burness and Dickson, Solicitors, Montrrose	" 5
Exmouth—Additions to 15, The Parade	James Pulsford	R. M. Challice, Architect, 9, Bedford-circus, Exeter	" 7
Kelvedon—Brewery Store	John Fuller	Geo. E. Clare, Architect, Chelmsford	" 7
Sandbach—Alterations to House and Shop in Bond-street	Industrial Co-operative Society	Alfred Price, Architect, Sandbach	" 7
Lochee—Servants' Room at Invermark Lodge		Jenkins and Marr, Architects, 16, Bridge-street, Aberdeen	" 7
Cwmbran—Police Station	Standing Joint Committee	William Tanner, F.S.I., County Surveyor, Monmouth	" 7
South Acton—House and Laundries, Park-road North	Henry Hawkes	Edward Monson, F.R.I.B.A., 22, Buckingham-st., Adelphi, W.C.	" 7
Keith—Shop and House, Mid-street	Corporation	John Alcock, Architect, Keith	" 7
Liverpool—Repairs to St. George's Baths	Urban District Council	W. R. Court, 15, Great George-square, Liverpool	" 7
Hipperholme—Offices, House, Store-Sheds, &c.		J. E. and E. H. Hill, Solicitors, 4, Harrison-road, Halifax	" 7
London—Enlargement of Fire-Engine Stations in Heath-street, Hampstead, and Simpson-street, Battersea	London County Council	C. J. Stewart, Clerk, Spring-gardens, S.W.	" 8
Belfast—Hardware Store and Sample Room	Guardians	Young and Mackenzie, Engineers, Donegal-square East, Belfast	" 8
Catcliffe—Three Houses and Saleshop	Dr. Donaldson	J. Platts, Architect, Old Bank Buildings, High-street, Rotherham	" 8
Dunning—Dwelling-House	School Board	David Smart, Architect, Perth	" 8
Monk Bretton—Additions, Smithies School		Wade and Turner, Architects, 10, Pitt-street, Barnsley	" 8
Ilkley—House, Eaton-road	Coastguard	E. B. Johnson, Architect, Ilkley	" 8
Hove—Three Dwelling Houses	Director of Works Department, Admiralty, Northumberland-avenue	Director of Works Department, Admiralty, Northumberland-avenue	" 8
Stowmarket—Villa, Bridge-st., & Two Cottages, Lime Tree-lane	Co. Diaper	H. G. Bishop, M.S.A., Market Place, Stowmarket	" 9
Wimbleton—Electric-Lighting Station and Chimney Shaft	Urban District Council	W. H. Whitfield, Clerk, Broadway, Wimbledon	" 9
Saltaire—Four Houses		James Young and Co., Architects, 62, Market-street, Bradford	" 9
Hull—Alterations to Technical School, Park-street	Corporation	E. Laverack, Town Clerk, Town Hall, Hull	" 9
Corbridge-on-Tyne—Additions to Sandhoe House	Colonel Hornby	Joseph Potts and Sons, Architects, 51, John-street, Sunderland	" 9
Waterfoot—Eight Cottages, Millerbarn-lane		Chairman, Industrial Co-op. Soc., Waterfoot, Lanes	" 9
Keighley—Warehouse, Low-street Mile	Sugden and Keighley	W. and J. Bailey, Architects, 1, Scott-street, Keighley	" 9
Sunderland—Infirmary Buildings at Workhouse, Hylton-road	Guardians of Sunderland Union	J. W. Hodgson, Clerk to Trustees, 17, John-street, Sunderland	" 9
Killberg—St. Columbia's Industrial School	Municipal Charity Trustees	William H. Byrne, Architect, 20, Suffolk-street, Dublin	" 10
Salisbury—Two Houses in Brown-st. and Three in Gigant-st.		H. Fulton, Clerk, Salisbury	" 10
Halifax—Pair of Semi-detached Villas, Saville Park	Corporation	Medley Hall, Architect, 29, Northgate, Halifax	" 10
Plymouth—Blocks of Dwellings		Jas. Paton, Borough Surveyor, Plymouth	" 10
Berwick—Dwelling House, Tweed-street	St. Mary Islington Guardians	Wm. Gray, Architect, 2, Ivy-place, Berwick-on-Tweed	" 10
Highgate Hill, N.—Infirmary (for 800 patients), &c.		Edwin Davey, Clerk, St. John's-road, Upper Holloway, N.	" 10
Plymouth—Rebuilding Boot Inn	Corporation	B. P. Shires, A.R.I.B.A., Central Exchange, Plymouth	" 10
Kingston-on-Thames—Market Stalls	Co-operative Provision Society	H. A. Winsor, Town Clerk, Kingston-on-Thames	" 10
Carrigans—Teachers' Residence	Guardians	R. Eccles Buchanan, Architect, 33, Shipquay-street, Derry	" 10
Bury—Stables, Knowsley-street		Thomas Nuttall, Architect, 20, Market-street, Bury, Lanes	" 10
Cardigan—Alterations at Workhouse	Coastguard	D. Davies, Clerk, Cardigan	" 10
Hayle—Nine-roomed House	Workmen's Doctor's Fund	John Lane, Riviere Cottage, Hayle	" 11
Gwersyllt—Enlargement of National Schools	Lyric Company, Limited	J. Bradshaw, Glanllyn, Gwersyllt	" 11
Dungeness—Eleven Houses, &c.	Guardians	Director of Works Department, Admiralty, Northumberland-avenue	" 11
Halifax—Additions to West Vale Mills	Infirmary and Asylum Corporation	C. L. F. Horsfall and Sons, Architects, Lord-st. Chambers, Halifax	" 12
Ebbw Vale—Surgery	Corporation	Thomas Evans, Secretary, Estate Office, Ebbw Vale Works	" 12
Wrexham—Three Houses, Empress-road	Very Rev. Matthew Ryan, PP.	Thos. Breeze, 24, Empress-road, Wrexham	" 12
Findhorn—Villa	Trustees of the Clyde Navigation	John Forrest, Architect, 120, High-street, Forres	" 12
Aberdare—Theatre	Theatre Royal Company	T. Roderick, Architect, Clifton-street, Aberdare	" 12
Penycraig—Renovating C.M. Chapel	School Board	T. D. Evans, Architect, Hendrecafan-road, Penycraig	" 12
Halifax—Two Houses, Mile Cross Estate	Guardians	F. L. Horsfall and Son, Architects, Lord-street, Halifax	" 12
Uckfield—Casual Wards at Workhouse	Infirmary and Asylum Corporation	F. Holman, Clerk, Lewes	" 14
Aberdeen—Additions to Daviot Branch Lunatic Asylum	Corporation	Geo. Taylor, Clerk of Works, Aberdeen Asylum	" 14
Buckley—Extension of Schools	Very Rev. Matthew Ryan, PP.	J. H. Davies and Sons, 24, Newgate-street, Chester	" 14
Hastings—Five Ornamental Covered Seats, Sea Front	Trustees of the Clyde Navigation	P. H. Palmer, Engineer, Town Hall, Hastings	" 14
Doneskae—Parish Church	Theatre Royal Company	Walter G. Doolin, M.A., Architect, Dawson Chambers, Dublin	" 14
Halifax—Corn Warehouse, Stabling, &c.	School Board	J. F. Walsh, Architect, Halifax	" 14
Glasgow—Timber Depot, &c.	Guardians	James Deas, Clyde Navigation Chambers, 16, Robertson-st., Glasgow	" 14
Barnsley—Reconstruction of Theatre	Edmonton School Board	Herbert Crawshaw, Architect, 13, Regent-street, Barnsley	" 14
Rowley Regis—Alterations at Tidivale Board School	John Binns and Sons, Ltd.	J. T. Meredith, Kidderminster	" 14
Boston, Spa—Alteration of Shop Premises	Town Council	Buttery and Birds, Architects, Queen-street, Morley	" 14
Blackburn—Probationer House for Pauper Children	John Binns and Sons, Ltd.	Robt. C. Radcliffe, Clerk, Cardwell-place, Blackburn	" 15
Lower Edmonton—Eldon-road Schools	Town Council	John Moule, Clerk, School Board Offices, Upper Edmonton	" 15
Notting Hill—New Vestries, All Saint's Church	John Binns and Sons, Ltd.	C. Hodgson Fowler, F.S.A., Durham	" 15
Cowling—Warehouse to Croft Mills	Town Council	James Hartley, Architect, Exchange Buildings, Skipton	" 15
Dover—Cart-shed at Union-road	Fawley School Board	E. Wollaston Knocker, Town Clerk, Castle Hill House, Dover	" 15
Halifax—Toolworks and Showrooms, Fenton-road	School Board	T. Lister Patchett, Architect, George Street Chambers, Halifax	" 15
Ipswich—Higher-Grade School, Tower Ramparts	Wils County Council	D. Davy, Clerk, Cadland, Southampton	" 15
Devises—Additional Story to Infectious Hospital	Board of Guardians	J. Hepburn Hume, Clerk, Tower House, Tower-street, Ipswich	" 15
Notting Hill, W.—Vestries, All Saint's Church	Schultz Gunpowder Co.	Chas. S. Ayle, County Surveyor, County Offices, Trowbridge	" 16
Stoke-on-Trent—Vagrant and Receiving Wards	Town Council	Boreham and Morton, Surveyors, Sunderland	" 16
Redbridge—Factory Buildings	Northern Co-operative Co.	C. Lynham, Architect, Stoke-on-Trent	" 16
Gravesend—Market and Fire-Engine Station, Steam-Roller House, Mortuary, and Weights and Measures Offices	School Board	Lemon and Blizard, Engineers, Castle-lane, Southampton	" 16
Aberdeen—Warehouse, Berryden-road	Corporation	Chas. E. Hatten, Town Clerk, Court House, Gravesend	" 17
Frinton-on-Sea—School (to accommodate 150 children)	School Board	R. G. Wilson, Architect, 181A, Union-street, Aberdeen	" 17
Avonmouth—Granary	Bristol Docks Committee	A. R. Chamberlayne, Clerk, Station-road, Clacton-on-Sea	" 18
Halifax—House, Rhodes-street	Standing Joint Committee	The Secretary of the Docks Committee, 19, Queen-square, Bristol	" 18
Hereford—Repairs to Front of Shire Hall	School Board	F. L. Horsfall and Son, Architects, Lord-street, Halifax	" 19
Findhorn—Villa	Corporation	J. F. Symonds, Clerk of the Peace, Shire Hall, Hereford	" 19
Bath—Enlargement of Oak Street Schools	School Board	John Forrest, Architect, 129, High-street, Forth	" 19
Plymouth—Refuse Destructor	Committee of St. Ives M.N.C. Chapel	William J. Wilcox, Architect, 1, Belmont, Bath	" 21
Neath—Schools, Gnoil Park-road (for 950 children)		Jas. Paton, Borough Surveyor, Plymouth	" 21
Leeds—Four Shops, Central-road		J. Cook Rees, St. Thomas's Chambers, Neath	" 21
St. Ives—Chapel and Schoolroom		The Town Clerk, Town Hall, Leeds	" 21
Paulton—Wesleyan Day School		Rev. S. Wright, St. Ives, Cornwall	" 22
		W. F. Bird, Architect, Midsomer, Norton	" 24

BUILDINGS—continued.

Llanrwst—Alterations to Court House	Sunderland—Bridge, Station Buildings, and Approaches at Palfion Station	Middlesbrough—Extension of Dock	Rugby—Additions to Graziers' Arms Inn	Ramsgate—Altering No. 34, Westcliffe	Folkestone—Factory Chimney (150ft. high), Electricity Supply Works	Weston-super-Mare—Rebuilding Pavilion	Hereford—Three Villas, White Cross-road	Harrogate—Additions to Harlow Inn, Harrogate	Llanely—Stables and Out-Buildings, Maesardafan	Brixham—New Roof, St. Mary's Church	Annam—Station Hotel	Finodon—Six Houses, Banks-road	Cheadle Hulme—Additions to All Saints' Church	Ightenhill—Farmhouse and Homestead, Hill Farm	Leeds—Victoria Arcade, Lands-lane and Upperhead-row	Harrogate—House	Killinure—Rebuilding Mansion and Building Farm Offices	Kirkstall—Sixteen Houses	Leeds—Sunday School, Ventnor-street	Manchester—Two Shops and House at Fairfield	Halifax—Converting Two Shops into Bathrooms	Ilkley—Steam Laundry, Cottages, and Stables	Borstal, Kent—Four Cement Kilns and Chimney	Newlay—Additions to House	Hull—Additions to Shop, Hessele-road	Cork—House, Douglas-road	Dersingham—Additions to Public-House	Newcastle-on-Tyne—Villa, Rowland's Gill	Llanely—Three Villas and Residences, New-road	Clifton—Free Methodist Chapel, Jacob's Well	Harrogate—House	Newark—Six Residences, Spital Estate	Euxton—Farm Buildings at Runshaw Moor	Filey—Pair of Villas	Haslingden—Workmen's Club	Garforth Colliery—Eight Cottages	Bangor, Co. Down—Presbyterian Church	Ramsgate—Wing to Grammar School	Devonport—Rebuilding the Shades Inn	Bramley—Two Terrace Houses, Victoria Park Estate	Barrow-in-Furness—Alterations to House	Abertillery—134 Colliery Houses at Six Bells	Chingford—Block of Shops	Clones—Creamery	Buxton—Twelve Cottages, Harpur Hill	Derrygonnelly—Creamery	Burley-in-Wharfedale—Ten Workmen's Houses	Denbighshire County Council	North-Eastern Railway	North-Eastern Railway	Northampton Brewery Company	Pier Company	Mrs. Griffiths	Charles Lilley	F. W. Dawson	A. Bell	Hyde's Brewery Co., Rusholme	Sanitary Steam Laundry Co.	William Braithwaite	J. Wolfe	Wm. Dixon	Trustees	Miss Stevens	Major C. J. Russel, Malton	Owners of Garforth Colliery	Headmaster	W. Postlethwaite	Co-operative Creamery	J. Gordon Black, Harrogate	Ll. Adams, Clerk of Peace, 5, Castle-street, Ruthen	C. N. Wilkinson, Secretary, York	C. N. Wilkinson, Secretary, York	T. W. Willard, Architect, Rugby	J. Buckhouse, 15, Rising-street, Ramsgate	Reginald Pope, Architect, Folkestone	Price and Wooler, Architects, Waterloo-st., Weston-super-Mare	W. W. Robinson, Architect, 10, King-street, Hereford	H. E. and A. Bown, Architects, Harrogate	W. Griffiths, Architect, Falcon Chambers, Llanely	J. C. Martin, Luzon, Brixham, Devon	F. J. C. Carruthers, Architect, 25, Buccleugh-street, Dumfries	Mosley & Anderson, Architects, Goodyear Chambers, Northampton	Frank Bindloss, Architect, 4, Chapel-walks, Manchester	Kay-Shuttleworth Estate Office, Gawthorpe Hall, Burnley	Ambler and Bowman, Architects, 9, Park-place, Leeds	William Squires, Architect, Royal Exchange Chambers, Leeds	F. P. Metge, C.E., 9, Hartcourt-terrace, Dublin	Percy Robinson, Architect, 340, Burley-hill, Leeds	W. F. Braithwaite, Architect, 6, South-parade, Leeds	Tom Cook, M.S.A., Architect, 39, Victoria Buildings, Manchester	Wm. Bennett, Superintendent, Royal Baths, Harrogate	Baxendall and Critchley, Architects, The Grove, Ilkley	The Secretary, Borstal Manor Cement Co., Borstal	J. Peakman, Architect, Hopwood Bank, Horforth	E. Whitlock, Architect, 26, Scale-road, Hull	Arthur Hill, B.E., M.R.I.A., 22, George's-street, Cork	Louis F. Eagleton, Architect, Bank Chambers, King's Lynn	W. Routhwaite, A.R.I.B.A., Archt., Mosley-st., Newtyle-on-Tyne	W. Griffiths, Architect, Falcon Chambers, Llanely	A. R. F. Trew, M.S.A., 22, Broad-street, Bristol	William Squires, Royal Exchange Chambers, Leeds	Abraham Friend, Architect, 50, Bowbridge-road, Newark	Jolly and Buckley, Architects, High-street, Chorley, Lancs	C. H. Channon, Architect, Malton	The Secretary, Station-road, Haslingden	R. Routledge, Manager, Garforth Colliery	Wm. J. W. Roome, M.S.A., Whitehall Buildings, Ann-st., Belfast	Jas. Emes, Architect, 151, Ebury-street, S.W.	B. Priestley Shires, Architect, Central Exchange, Plymouth	A. E. Dixon, A.R.I.B.A., Architect, 5, Park-lane, Leeds	E. M. Young, Architect, 90, Duke-street, Barrow	C. Telford Evans, Architect, 8, Queen-street, Cardiff	J. Edward Still, Architect, 82, Queen-street, Cheapside, E.C.	Geo. F. Graham, President, Clones	The Buxton Lime Firms Company, Limited, 8, Quadrant, Buxton	D. Donaldson and S. G. Linton, Hon. Secretaries, Derrygonnelly	Whitehead and Smetham, Architects, Albert Chambers, Harrogate
-------------------------------------	-------------------------------------------------------------------------	---------------------------------	---------------------------------------	--------------------------------------	--------------------------------------------------------------------	---------------------------------------	-----------------------------------------	----------------------------------------------	------------------------------------------------	-------------------------------------	---------------------	--------------------------------	-----------------------------------------------	-----------------------------------------------	-----------------------------------------------------	-----------------	--------------------------------------------------------	--------------------------	-------------------------------------	---------------------------------------------	---------------------------------------------	---------------------------------------------	---------------------------------------------	---------------------------	--------------------------------------	--------------------------	--------------------------------------	-----------------------------------------	-----------------------------------------------	---------------------------------------------	-----------------	--------------------------------------	---------------------------------------	----------------------	---------------------------	----------------------------------	--------------------------------------	---------------------------------	-------------------------------------	--------------------------------------------------	----------------------------------------	----------------------------------------------	--------------------------	-----------------	-------------------------------------	------------------------	-------------------------------------------	-----------------------------	-----------------------	-----------------------	-----------------------------	--------------	----------------	----------------	--------------	---------	------------------------------	----------------------------	---------------------	----------	-----------	----------	--------------	----------------------------	-----------------------------	------------	------------------	-----------------------	----------------------------	-----------------------------------------------------	----------------------------------	----------------------------------	---------------------------------	-------------------------------------------	--------------------------------------	---------------------------------------------------------------	------------------------------------------------------	------------------------------------------	---------------------------------------------------	-------------------------------------	----------------------------------------------------------------	---------------------------------------------------------------	--------------------------------------------------------	---------------------------------------------------------	-----------------------------------------------------	------------------------------------------------------------	-------------------------------------------------	----------------------------------------------------	------------------------------------------------------	-----------------------------------------------------------------	-----------------------------------------------------	--------------------------------------------------------	--------------------------------------------------	-----------------------------------------------	----------------------------------------------	--------------------------------------------------------	----------------------------------------------------------	----------------------------------------------------------------	---------------------------------------------------	--------------------------------------------------	-------------------------------------------------	-------------------------------------------------------	------------------------------------------------------------	----------------------------------	-----------------------------------------	------------------------------------------	----------------------------------------------------------------	-----------------------------------------------	------------------------------------------------------------	---------------------------------------------------------	-------------------------------------------------	-------------------------------------------------------	---------------------------------------------------------------	-----------------------------------	-------------------------------------------------------------	----------------------------------------------------------------	---------------------------------------------------------------

ENGINEERING.

Radcliffe—Tanks, Filter Beds, &c.	Newport—Steam Travelling Crane	Buckfastleigh—Outfall and Purification Works	Swansea—Reconstruction of Storm Water Overflow	Belfast—Locomotive Steam Crane	Hexham—Gasholder Tank	Rhyl—Extension of West Promenade	Appleton Wishe—Masonry of Iron Bridge	Teignmouth—Covering Landscore Reservoir, &c.	St. Andrew's—Extension of Harbour	Holmside Village—Sewage Tanks, Bacteria Beds, &c.	Teignmouth—Relining Hazeldown Reservoir, &c.	Hamilton—Pipelining (about 13 miles of cast-iron pipes)	Barton-on-Humber—Tank and Gasholder	Hamilton—Boilers and Pumping Engines	Warkworth—Improving Houdean Bridge	Clietheroe—Water-Main, &c.	Redditch—Electric Lighting Works	Leeds—Laundry Machinery at Workhouse	Sheerness—Pier (1,294ft. in length)	Wednesbury—Widening Bridge over Canal	Dezives—Two Steel Lancashire Boilers	Middleton—Purifiers at Gasworks	Balsall Heath—C.I. Well Cylinders, Moseley-road Baths	Balsall Heath—Well Sinking	Uppermill—Rebuilding Bridge	Portland—Waterworks	Bridgnorth—Provision and Laying of a 7in. Main (1,800 yards in length)	Plymouth—Dock Entrance	Martley—Water Supply Works	Denbigh—Cooking Apparatus at North Wales Lunatic Asylum	Guipuzcoa, Bilboa—Electric Tramway (30 miles) from Zumarrago to Zumaya	Pernambuco—Port Works	Dorstone—Carriage Bridge across the Dore	Llangathen—Stone Bridge, Dryslwyn Ford	Sophia—Electric Lighting of Town	Madras—Utilisation of Water of Periyar Lake	Leeds—Settling Tank, Meanwood Tannery	Northampton—Water Main, &c. (two miles)	Brindisi—Works to Harbour	Roscommon—Drying Apparatus in Workhouse	Urban District Council	Corporation	Urban District Council	Urban Sanitary Authority	Harbour Commissioners	Gas Company	Urban District Council	Northallerton Rural District Council	Urban District Council	Fishery Board for Scotland	Lanchester Rural District Council	Urban District Council	District Committee of Middle Ward	Gas Company	District Committee of Middle Ward	Alnwick Rural District Council	Corporation	Urban District Council	Guardians	Urban District Council	Corporation	Visiting Com. Wilts County Asylum	Corporation	Birmingham Corporation	Birmingham Corporation	West Riding County Council	Urban District Council	Corporation	Great Western Railway Company	Rural District Council	Commercial Department of Foreign Office, Whitehall, S.W.	Brazilian Ministry of Public Works, Rio de Janeiro	J. F. Symonds, Clerk, Shire Hall, Dorstone	Thomas Jones, Clerk, County Council Offices, Llandovery	The Mayor, Sophia, Bulgaria	Chief Engineer for Irrigation, Madras	Thomas Winn, Architect, 90, Albion-street, Leeds	Wm. Hull, Architect, 12, St. Giles's-street, Northampton	Commercial Department, Foreign Office, Whitehall, S.W.	Ty. O'Keeffe, Clerk, Union Office, Roscommon	J. Sharples, Clerk, Radcliffe	Albert A. Newman, Town Clerk, Newport	Edward Windeatt, Clerk, 19, High-street, Totnes	John Thomas, Town Clerk, Guildhall, Swansea	W. A. Currie, Secretary, Harbour Office, Belfast	Herbert Lees, A.M.I.C.E., Secretary, Gasworks, Hexham	Robert Hughes, Town Surveyor, Clwyd-street, Rhyl	W. Fowle, Clerk, Northallerton	W. R. Hall Jordan, Clerk, Town Hall, Teignmouth	D. and C. Stevenson, Civil Engineers, 84, George-street, Edinburgh	W. H. Ritson, Clerk, Lanchester, Durham	W. E. Hall Jordan, Clerk, Town Hall, Teignmouth	Leslie and Reid, 72, Great George-street, Edinburgh	W. H. Goy, Secretary, Barton-on-Humber	Leslie and Reid, 72, Great George-street, Edinburgh	H. W. Walton, Clerk, Alnwick	J. E. Sharpe, Borough Surveyor, Clitheroe	J. A. McMullen, M.I.E.E., Hornchurch, Essex	James H. Ford, Clerk, East Parade, Leeds	Vincent H. Stallon, Clerk, Trinity-road, Sheerness	E. Martin Scott, Borough Engineer, Town Hall, Wednesbury	Joseph T. Jackson, Clerk, Dezives	Timothy Duxbury, Gas Engineer, Gasworks, Middleton	J. F. Cox, Superintendent Engineer, Kent-street, Birmingham	J. Cox, Superintendent Engineer, Kent-street, Birmingham	J. Vickers Edwards, County Surveyor, Wakefield	Ernest J. Eilford, C.E., Engineer, Council Offices, New-rd, Portland	J. Taylor, Sons, & Santo Crimp, C.E., 27, Gt. George-st., Westminster	G. K. Mills, Secretary, Paddington Station, London	A. W. Knott, Clerk, 14, Foregate-street, Worcester	Wm. Barker, Clerk to the Visitors, Denbigh
-----------------------------------	--------------------------------	----------------------------------------------	------------------------------------------------	--------------------------------	-----------------------	----------------------------------	---------------------------------------	----------------------------------------------	-----------------------------------	---------------------------------------------------	----------------------------------------------	---------------------------------------------------------	-------------------------------------	--------------------------------------	------------------------------------	----------------------------	----------------------------------	--------------------------------------	-------------------------------------	---------------------------------------	--------------------------------------	---------------------------------	-------------------------------------------------------	----------------------------	-----------------------------	---------------------	------------------------------------------------------------------------	------------------------	----------------------------	---------------------------------------------------------	------------------------------------------------------------------------	-----------------------	------------------------------------------	----------------------------------------	----------------------------------	---------------------------------------------	---------------------------------------	-----------------------------------------	---------------------------	-----------------------------------------	------------------------	-------------	------------------------	--------------------------	-----------------------	-------------	------------------------	--------------------------------------	------------------------	----------------------------	-----------------------------------	------------------------	-----------------------------------	-------------	-----------------------------------	--------------------------------	-------------	------------------------	-----------	------------------------	-------------	-----------------------------------	-------------	------------------------	------------------------	----------------------------	------------------------	-------------	-------------------------------	------------------------	----------------------------------------------------------	----------------------------------------------------	--------------------------------------------	---------------------------------------------------------	-----------------------------	---------------------------------------	--------------------------------------------------	----------------------------------------------------------	--------------------------------------------------------	----------------------------------------------	-------------------------------	---------------------------------------	-------------------------------------------------	---------------------------------------------	--------------------------------------------------	-------------------------------------------------------	--------------------------------------------------	--------------------------------	-------------------------------------------------	--------------------------------------------------------------------	-----------------------------------------	-------------------------------------------------	-----------------------------------------------------	----------------------------------------	-----------------------------------------------------	------------------------------	-------------------------------------------	---------------------------------------------	------------------------------------------	----------------------------------------------------	----------------------------------------------------------	-----------------------------------	----------------------------------------------------	-------------------------------------------------------------	----------------------------------------------------------	------------------------------------------------	----------------------------------------------------------------------	-----------------------------------------------------------------------	----------------------------------------------------	----------------------------------------------------	--------------------------------------------

FENCING AND WALLS.

Faughawale—Boundary Walls and Rails	East Ham—Wrought-Iron and Oak Fencing	Bakewell—Boundary Wall at Oakhouse	Plaitow—Dwarf Wall & Fence, Hermit Road Recreation Ground	Dalston, Cumberland—Brick Wall, Barras-lane	Morley—Retaining Wall and Culvert, The Bottoms	Hastings—Boundary Walls, Clarification Works, Bulverhythe	Committee of Presbyterian Church	Urban District Council	Guardians	West Ham Town Council	Carlisle Rural District Council	Corporation	Corporation	W. Barker, Architect, 3, Richmond-street, Londonderry	W. H. Savage, Surveyor, Public Offices, East Ham	A. Howes, Clerk, Union Offices, Bakewell	F. E. Hilleary, Town Clerk, Town Hall, West Ham	J. Bell, Surveyor, 1, Aglionby-street, Carlisle	M. H. Sykes, Borough Surveyor, Town Hall, Morley	P. H. Palmer, M.I.C.E., Borough Engineer, Town Hall, Hastings
-------------------------------------	---------------------------------------	------------------------------------	-----------------------------------------------------------	---------------------------------------------	------------------------------------------------	-----------------------------------------------------------	----------------------------------	------------------------	-----------	-----------------------	---------------------------------	-------------	-------------	-------------------------------------------------------	--------------------------------------------------	------------------------------------------	-------------------------------------------------	-------------------------------------------------	--------------------------------------------------	---------------------------------------------------------------

FURNITURE AND FITTINGS.

Scarborough—Wards of New Wing of Infirmary	Dewsbury—Furniture, &c., for New Cottage Homes	Guardians	Guardians	W. O. Woodall, Clerk, 32, Queen-street, Scarborough	Joseph Peace, Clerk, Union Offices, Wellington-street, Dewsbury
--------------------------------------------	------------------------------------------------	-----------	-----------	-----------------------------------------------------	-----------------------------------------------------------------

PAINTING.

Halifax—Chapels, Stony Royd Cemetery	Southend-on-Sea—Sanatorium, Balmoral-road	Bourne, Sleaford—Sessions House, Bourne, and Court of Sessions House	Stockport—Painting, &c., Market Hall and Cellars	Manchester—Various Stations	Rochdale—Board-room and Offices, Townhead	Blackburn—Fever Hospital, Longshaw-lane	Prestwich—Outside Works at the County Asylum	Nottingham—Cleaning and Decoration of Bulwell Wesleyan Chapel	Parks Committee	Corporation	Memorial Tolls Committee	Lancashire and Yorkshire Ry. Co.	Guardians	Health Committee	Committee of Visitors	Edward R. S. Escott, C.E., Borough Engineer, Town Hall, Halifax	Alfred Fidler, A.M.I.C.E., Borough Surveyor, Southend	Herbert Kirk, County Surveyor, Sleaford	John Atkinson, Borough Surveyor, St. Petersgate, Stockport	C. W. Bayley, Secretary, Hunt's Bank, Manchester	R. A. Leach, Clerk, Union Offices, Townhead	William Stubbs, Borough Engineer, Municipal Offices, Blackburn	Superintendent, County Asylum, Prestwich	Arthur Marshall, A.R.I.B.A., Architect, King-street, Nottingham
--------------------------------------	-------------------------------------------	----------------------------------------------------------------------	--------------------------------------------------	-----------------------------	-------------------------------------------	-----------------------------------------	----------------------------------------------	---------------------------------------------------------------	-----------------	-------------	--------------------------	----------------------------------	-----------	------------------	-----------------------	-----------------------------------------------------------------	-------------------------------------------------------	-----------------------------------------	------------------------------------------------------------	--------------------------------------------------	---------------------------------------------	----------------------------------------------------------------	------------------------------------------	-----------------------------------------------------------------

# THE BUILDING NEWS

## AND ENGINEERING JOURNAL.

VOL. LXXIV.—No. 2249.

FRIDAY, FEBRUARY 11, 1898.

### SOLIDITY AND STRAW.

**S**OLIDITY as a quality in building has something to do with the temperament and moral character of the builder. We cannot expect it from a man who is accustomed to look only on the outside of things, who has been used to study showy elevations or materials. Cost often lies at the bottom. The desire to build cheaply and ostentatiously lends itself fatally to shallowness of building and shams. Cheapness in building has favoured all sorts of artificial substitutes for real material, veneered walls of ashlar, or terracotta or slabs of faience, cased columns and beams, tolerable in their way if used within certain limitations, but grievously deceptive if made to represent structure. And has not the education of the younger generation of architects suffered from this low ideal of building? We think it has. The present generation is more superficial in many things. They know more trades, but not any one trade well. Take brickwork or masonry. Bond and masonry construction is taught in the technical school, but not practically. It would be hardly fair to say that our "up-to-date" student who "crams" for the examinations of any of the technical colleges, at the Institute, or for the exams. of the Science and Art Department at Kensington is so well up in practical carpentry or masonry as his predecessors. The young architect of the last generation may not have known so many methods and applications of graphic statics as the youth of to-day, but we suspect he was better acquainted with carpentry as a trade, and could design a roof truss with greater ease. Does it not also appear that this superficial tendency in the architect's education has something to do with the flippancy and shallowness of architectural taste, that it corresponds with the pretentiousness of modern buildings? If we take any dozen of the many business and commercial premises in our streets, what do they show but mere "skin-deep" ornamentation, and that of a very poor kind? Of depth, of modelling, of light and shade there is nothing—the designer has merely studied his elevation as a flat surface, and the work is either of ornamental terracotta, or faience, or brickwork. In the details of the shop-fronts, the beauty of stained glass and metalwork is sought to be reproduced by the modern manufacturer. The "pattern book" is brought into requisition, for we may see the same design in the next street; but all is flat or coarse, and in a few months the front loses its freshness, and it all looks tame and commercial. Inside, various fabrics represent solid oak or plaster, solid marble or metal; but there is no solidity or substance behind, except rough stock brick walls, iron stanchions, and wooden partitions.

In no other profession is shallowness so soon discovered as in that of the architect. The man of shallow legal knowledge who undertakes to prosecute or defend in an action may fairly survive his weak law; a man of superficial knowledge, as a professor or a lecturer, may even be rewarded; but the shallow architect, who knows only his profession from books, or who has learned only the rudiments of the art, quickly comes to grief whenever he attempts to put his ideas into practice. An accomplished and captivating draughtsman, unless he knows the technicalities of building, has seldom, single-handed, been able to achieve success, because he has not the ability to translate

his ideas into brick, stone, timber, or metal. Thoroughly competent as an artistic draughtsman, he has still only learned one side, and that the most attractive one of the solid fact we call building. He deals with surfaces and elevations, and can even make taking perspectives representing the solid building in its other dimensions; but he knows little of what underlies the several surfaces. His work, so to speak, is the mere envelope of the solid; his perspective is not modelling, but drawing in the "flat."

Nor does the man who has studied the theory only of his profession get on much better. His attainments languish or desert him when they are brought to the test of practical work, and he finds that, in spite of his theoretical knowledge, the practical "rule-of-thumb"—and often ignorant—workman has the best of him. In Sir John Wolfe Barry's remarks addressed to students at the Institute of Civil Engineers, these very trite but applicable words appear:—"Practical training can only be secured in the old-fashioned way by a young man seeing work done and learning from it the lessons of experience. In the engineer's office, in the workshops, and on works of construction, and these only, can a young engineer learn by experience what he can usefully assimilate and what he ought to reject, and then only will he be brought face to face with the demonstration of how largely the conclusions of theory have to be modified and discounted by practical considerations and the limits of the attainable." These last words contain in a nutshell the gist of the whole disagreement between theory and practice. The "limits of the attainable," or the limitations of the material, constantly make it very difficult to reconcile theory with the practical in building.

We presume many things in theory that do not practically exist. In dealing with masonry or brickwork construction, cement or mortar is often neglected, the wall is considered as a homogeneous mass exercising a uniform weight over a beam, whereas, in fact, it is a rigid coherent mass, and the weight on the beam would be more of a concentrated load on the centre; in other words, the effect of the bond or cohesion of mortar is not taken into account. Again, in our theoretical treatises on the arch, the voussoirs are often regarded as loose stones without friction or cement, or as a fluid pressure, instead of which, in actual failure of the arch, we find segments of it slipping down, or the crushing of certain stones. We talk of a thrust overturning a mass of masonry, or its sliding on a bed; the real fact is, the abutment gives way at a weak joint, or by yielding at the foundation. The breaking of an iron girder is not so often due to the want of flange section as to some flaw in the iron; and iron columns designed on strictly mathematical principles are found to fail from imperfect bedding throwing the line of pressure on one side of the real axis, or through some flaw in the casting. And it is the same with structures like roofs or bridges; their failure often arises from a defective connection or bolt, rather than from any fault in the design. All practical builders know how much is attributable to bad workmanship, which theory ignores altogether, and in this way theory has to be discounted by practical defects of execution. Hence we find that the mere draughtsman and the mere theorist have scarcely realised the ideal of an artistic building, though they go a long way towards the professional attainment necessary. Skill in modelling, so valued by the great sculptor-architects of the Renaissance, is lost sight of. We should like to see the art of modelling again take the position it once did. We do not mean to say it should take the place of construction or drawing, but it may very usefully be studied in connection with both these subjects in our designing classes. Solidity of

effect can scarcely be said to be learned by perspective; but the study of models would greatly aid the student of perspective. The modelling of a building or group of buildings has an educative use, which cannot be supplanted by mere plan and elevation drawing. Only the man of imaginative power can arrange his building or masses in such a way as to produce an effective grouping; we have instances in our leading architects of this power. The value of retiring planes of building, quadrangular masses, and open courts can only be learned by modelling. Unfortunately, we have now few opportunities. Buildings like the Louvre, our Somerset House, and many of the colleges at Oxford are not erected every day, though now and then, as at Sheffield and Cardiff Town Hall, and in other modern institutions, the quadrangle arrangement is made a feature. Mr. F. T. Baggalay's remarks on the exhibition of depth or the third dimension are to the point in this connection. The French suggest solidity by showing the roofs of their great buildings over and beyond the walls, but we are apt to neglect this effect.

Modern substitutes for older materials have seriously effected the solidity of buildings. Take, as one example, a wall faced or veneered with stone or marble. It is constructed of rough brickwork with large mortar joints, and is faced with stone ashlar. The backing settles as the mortar dries, while the facing of stone, with fewer and narrow joints, takes the whole weight or pressure, and the consequence is, the face-work bulges or separates from the backing or core, or the wall has a tendency to buckle on the side of the brick. The settlement and crushing of stone-faced piers or pillars supporting great weights, as some of our cathedral towers, is an instance of a pillar veneered externally by wrought stone. Owing to the subsidence of the rubble core, the external shell of stone receives all the weight, and crushing takes place. There is another aspect of the veneered wall and pier. It affects solidity. The external appearance of the veneer of wrought stone deceives the eye. We assume the wall or pillar is solid throughout, that the external facing represents solid stones bonded throughout, but it is not so. Take, as another instance, a deep jamb or "reveal"; the facing has to be returned round the angle of opening to produce the effect of solidness. It costs labour to build in this way, and it may be often worth while to consider whether the extra expense of returning a more expensive material round the corner is not quite as costly as using solid "through" stones of an inferior kind? Again, we often see the angle of a building returned over the roof of a lower block, like a wing, and it is usual to face the triangular-shaped piece of walling with the more expensive material of the front, to give the effect of solidity; but the plan has this disadvantage—viz., that it is shirked where possible, and costly facing materials are generally confined to flat surfaces. The architect, in short, begins to shirk return sides, and hence it is that the custom of using facing materials has led to superficial treatment. Veneering has much value as a decorative expedient. What are our mosaics, frescoes, marble, and faience linings but veneers to give beauty and colour to our brick and stone walls? But it has this danger—that it is often regarded as a substitute for solid buildings and materials of less value. The modernist, or the commercial man, says "Let us build a rough brick wall and line it with marble or faience." Instead of giving solidity or internal relief by pilasters and piers, the effect is obtained by tiles or panels in marble, or decorations of plaster or embossed material. Modern substitutes for internal decoration has, we must admit, lent a great temptation to superficial treatment, and made it less possible in these days to

build solidly. Let us look, for instance, at the architecture, if we can so dignify the application, of our great hotels and restaurants. Large capitals have been expended on these often lavish undertakings, but, with few exceptions, we can hardly say they are examples of design worthy the expense. Have not our public-houses vulgarised all that we esteem in stained glass, art faience, veneers, ceiling decoration, and metalwork. Many beautiful crafts and styles and materials have been applied indiscriminately to the decoration of bars, buffets, and restaurants, till we see Classical legends, Elizabethan and Tudor ornament, heraldic badges and details dragged from halls like Little Moreton, Bursleigh, and Longleat to adorn bars and coffee-rooms. To "such base uses" are these originals put, burlesqued, as they are, by the attenuated imitations of the manufacturer. *Sic transit* indeed may be inscribed on all such misappropriations.

#### PARTY-WALLS AND FOOTINGS.

WHEN a wall between two buildings forms a party-wall belonging one half to each, or when it is to be taken as two external walls, is a nice question often arising in cases brought into court. Architects, surveyors, and builders often stumble over the meaning, and the framers of Building Acts have found it difficult to make a definition that is entirely satisfactory. The definition of the term "party wall" in the London Building Act seems to have been drawn up with reference to ownership and occupation, as well as to user. There are two distinct meanings attached to the term in the Act—first, as a wall forming part of a building used, or constructed to be used, for separation of adjoining buildings belonging to different owners; second, as a wall "standing to a greater extent than the projection of the footings on lands of different owners." The latter of these seems to depend more on ownership, the former on user. Whether two "external" walls close together become a party-wall by usage is a moot question. A case of some interest came before the Chancery Court lately, and was reported in our last issue. Proceedings arose on a claim by certain plaintiffs for an injunction to restrain the defendants from erecting or allowing to remain erected any wall or any footing upon the land of the plaintiffs at No. 63, High-street, Clapham, and for damages sustained by them. The defendants contended that the London Building Act gave them the right in the circumstances to place footings upon plaintiffs' land, for the purpose of rebuilding a new wall. While a part of the house 63 was being pulled down, the southern flank wall of the said house fell, and, in its fall, damaged the northern flank wall of house No. 65. Evidence on one side was adduced to show that plaintiffs' and defendants' wall formed a party-wall belonging to the joint parties, one-half to each; but the defendants alleged that the whole of the wall was built on their property. The evidence as reported is not very clear as to the circumstances or construction of the wall. One witness spoke of a 4½ in. wall as not a sufficient inclosure. It could not have stood, and was a patchwork, not bonded. The defendants pleaded that the walls were distinct, in fact, two external walls, and evidence was brought in support of this opinion. We may confine ourselves to the summing-up of the Judge, who "found as a fact that plaintiffs and defendants had each an external wall built on their own premises respectively." As a matter of fact, the defendants' wall was an external one on their own land, "though they had committed a trespass in placing footings and foundations upon plaintiffs' land; that plaintiffs were at liberty to remove them, and

he awarded damages £15, including costs of removal of said footings." On the Judge's suggestion, defendants withdrew their counterclaim for damages to their house caused by the falling of the wall. "The plaintiffs desired the erection of the party-wall in place of the two walls, whereas the defendants had erected an independent wall as a structure to repair the house. The judge held that the defendants were right in the defence of the action; but he added that the Act did not give them a right to put their footings upon the plaintiffs' land."

The facts, as far as we can gather them, go to show how often so-called "party-walls," or walls of separation, are built or tampered with; this decision is against the assumption of the defendants to place footings upon their neighbours' land for the purpose of building a new wall. The Act does not, in short, give any right to put footings upon the adjoining owners' land. Had the wall not fallen and damaged the defendants' premises, this case would probably not have been heard of. We believe there are hundreds of houses in London separated by walls of this character built by both parties, where one party has built a thin wall on the footings of the adjoining owner. In the enlargement or extension of premises an independent wall is often constructed, but without any bond with the old wall. The consequence of this construction is that if A. happens to pull down his premises, or clear the site for rebuilding, B.'s independent wall is directly in peril, especially if the footings are touched. One may see numerous walls of this kind—a kind of piecemeal wall built against an older party-wall. Here and there the wall bulges, and very uneven and rough kind of brickwork is put up against it without any bond whatever.

Under the London Building Act, 1894, the rights of building and adjoining owners are set forth, so that in the future such instances as we have mentioned are less likely to happen. Thus, if a building owner desires to build a party-wall on the line of junction of the two lands, he has simply to serve notice on the "adjoining owner," describing the wall, and if the said adjoining owner consent, the wall is to be "built half on the land of each of the two owners," or in some other way as may be agreed, and the expense is to be defrayed by the two owners in due proportion, regard being had to the use which may be made of the wall by the two respectively. But if the adjoining owner does not consent to the building of a party-wall, the "building owner" may build the wall wholly on his own land as an "external wall," and he has also the right, at his own expense, a month after the service of notice to his neighbour, to place "on the land of the adjoining owner, below the level of the lowest floor, the projecting footings of the external wall with concrete," on making compensation for any damage caused thereby. When one external wall is built against another wall, the surveyor may allow the footing next thereto to be omitted. These regulations are just and reasonable. Sections 87 and 88 describe the rights of building owners to underpin, repair, or rebuild any party structure, to cut away footings or jambs from any parts or external wall in order to erect a wall against such party or external wall. If these rules were strictly observed, it would hardly be possible to find any disagreement between the owners of party and external walls. For although a building owner can do these things, the adjoining owner can require him to do certain other things for his own protection and convenience—to build chimney jambs, breasts, flues, copings, piers, &c. Unfortunately, these rules are not strictly observed; there is often a good deal of tension between the two owners, and each acts on his own responsibility. The decision of the Court refers particularly to the footings, the Judge held, as we

have seen, that the Act did not give the defendants a right to place their footings on the plaintiffs' land—a ruling that seems to be in conflict with subsection (6) of section 87, where it is provided that the building owner has, after notice, a right to place footings below the level of the lowest floor on the land of adjoining owner, making compensation for any damage. The point is certainly doubtful as regards an external wall, unless the footing on the side of the other external wall be omitted, as suggested by the last clause of the section. Subsection 6 and this clause are, doubtless, rather conflicting.

#### ROYAL INSTITUTE OF BRITISH ARCHITECTS.

THE seventh fortnightly meeting of the Institute of Architects for the present session was held on Monday evening at 9, Conduit-street, W., Mr. H. Louis Florence, Vice-President, in the chair. The secretary, Mr. W. J. Locke, announced that the Architectural Union Company had voted the sum of £30 as a donation towards the purchase of additional books for the library. On the motion of the Chairman, a vote of thanks was passed to the company for their generous gift, not the first of the kind made by the lessors of the premises in which the Institute have for so long had their habitat.

#### THE APOTHEOSIS OF AMIABILITY: A PROTEST.

The CHAIRMAN said it was his privilege that evening to make an announcement which was yearly awaited by members with some amount of curiosity and even excitement—namely, the name which, subject to the approval of the members, the Council unanimously decided to submit to Her Majesty the Queen as a fitting recipient for the Royal Gold Medal in Architecture for 1898. Under the peculiar circumstances of the nomination he felt it would be scarcely sufficient to make the bare statement of the name to be submitted. He could confidently say that no name was more familiar to the members of the institute, than the one the council proposed to recommend, that of their President, Professor Aitchison, R.A. (some applause), and not only was he well known to his professional brethren in the United Kingdom, the Colonies, and on the Continent, but the President was also the representative of the literary side of the art, of that culture and erudition which were less usual among architects of the present day than of the immediate past. He should like to explain that this name was selected by the Council before they learned that Professor Aitchison had been chosen as a full Academician—a position which they were glad he had attained after undergoing the ordeal of a close election. Members were acquainted with their President's work in architecture and decoration, and many of them longed to see his Academy lectures collected in a series of volumes.

Mr. WILLIAM WOODWARD said he rose with considerable reluctance to make a few observations on the announcement which had just been made—a reluctance which was increased by the hearty appreciation with which the nomination had been received, and in which he personally concurred. In making these remarks he did not intend the slightest reflection on the gentleman who had occupied the Presidential chair for the past two years. Personally, he yielded to no one in admiration for their President—his courtesy, geniality, good-nature, and perfect fairness in that chair were beyond praise, and the interest and charm of his addresses were gladly acknowledged by all. These very tributes to the President only formed the *raison d'être* of the observations he was about to make, and in which, he felt quite sure, he should have the meeting with him. Unless the award of this Medal was accompanied with the unanimous approval of the members, its bestowal became but a worthless bauble; but was their choice unfettered? If they referred to the wording of the Royal Charter, they would see that the Queen agreed to confer the Medal "at the recommendation of the Institute," and under By-law XI., section 63, it was provided that any twelve Fellows desiring to substitute any other name for the one recommended by the council, might sign a proposal addressed to the secretary containing the name to be substituted, at least fourteen days before the day of election. These extracts showed that the electorate was intended to be as wide as it was



"LESSING" THEATRE, BERLIN.

possible to make it within the ranks of the Institute. Now, what was the position of the members when the occupant of the Presidential chair was nominated by the Council for the Medal? It was almost impossible for members, however much they might feel the claims of some other architect had been overlooked, to vote for him in opposition to the President, and even should such

vious, moreover, that rarely would a dozen Fellows be found to lend their names to such a candidature. The nomination of any former occupant of the chair was obviously not open to the same objection. The proposal of Mr. Aitchison's name was premature, and would have come with far more grace after he had vacated the chair. He would close by offering

The CHAIRMAN: In reply to Mr. Woodward, I may say, firstly, that this is not an unprecedented action, a former president having been awarded the Royal Gold Medal during his term of office. (Mr. Woodward: Name.) I refer to Mr. Charles Barry; and, secondly, I may add that it seemed to us, as the Council generally, that in the year of Jubilee, in which architecture had not been specially recognised, some fitting honour should be bestowed on a leading architect. I think it will be felt by all that in this recommendation the Council have done well.

THE HOUSING OF THE DRAMA.

Mr. EDWIN O. SACHS then read a paper on this subject, illustrating his remarks with a very large collection of drawings, some of which we reproduce. In his introductory remarks the lecturer explained that he did not propose to deal with questions of constructions or planning. His endeavour was to treat some of the aspects under which a playhouse devoted to the production of drama could be constructed, not only as a temple of art, but also as the pride of the nation or community to which it belonged. These aspects, he considered, demanded the attention of the architectural and allied professions; for, without the assistance of the architect of to-day and his co-workers, the successful issue of any movement for a better class of building was almost impossible. He asked: How was the drama, in its highest sense, housed to-day? How was it housed in the Metropolis, how in the provinces, how abroad? What principle guided the constitution of the home of the drama? What was the basis on which buildings devoted to the presentation of plays are erected? The answers to these questions the author held to be all-important when considering whether a playhouse fulfilled the function for which it was provided. They were also essential, if we wished to know the line on which a modern playhouse ought to be built.

LONDON PRIVATE THEATRES.

The author proceeded to show that London had no other form of playhouse than what was termed the private theatre. However high a standard might be reached by productions associated with individual examples, private theatres could not be considered otherwise than having their basis in commercial enterprise. This commercial spirit was but rarely shaken off, even by a management of the highest order. It was important to define the distinction as to when a playhouse formed part and parcel of a theatrical business, and when it could simply be classed as an investment, the building being leased at its market value. It was shown, too, how for a theatre—whether built for direct management or as an investment—the site, the building, and the equipment were plain questions of rent-roll and £. s. d. What was more, the London playhouse was but seldom erected by the man who could sail an easy course with a large banking account at his back. With few exceptions, they

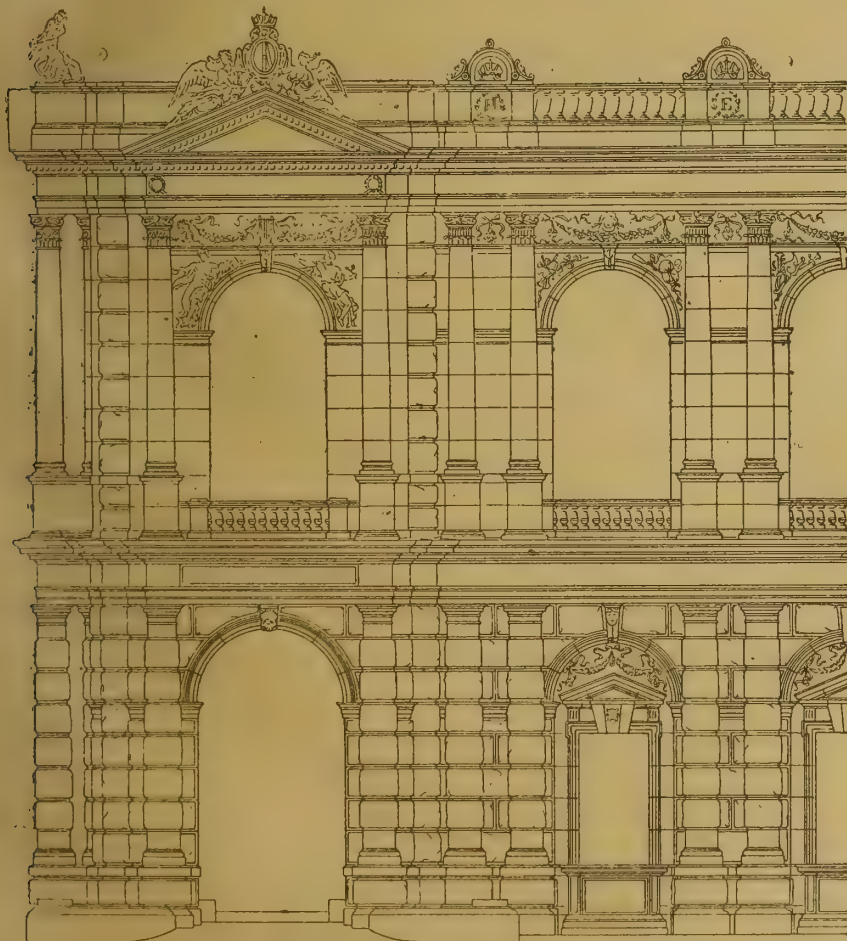

PART ELEVATION, COURT THEATRE, VIENNA.

a substituted name be generally accepted, it would detract very much from the value of an honour so conferred—indeed, the nominee so elected in opposition to the nomination of the Council would not be able to accept, at the hands of the President, the Medal with any degree of grace or self-respect. It was ob-

his most respectful protest against the principle in the proposal, and would ask that steps be taken to prevent such a nomination from being taken as a precedent. [The close of Mr. Woodward's remarks, which had been listened to in silence, was greeted with some applause from the younger members at the back of the room.]

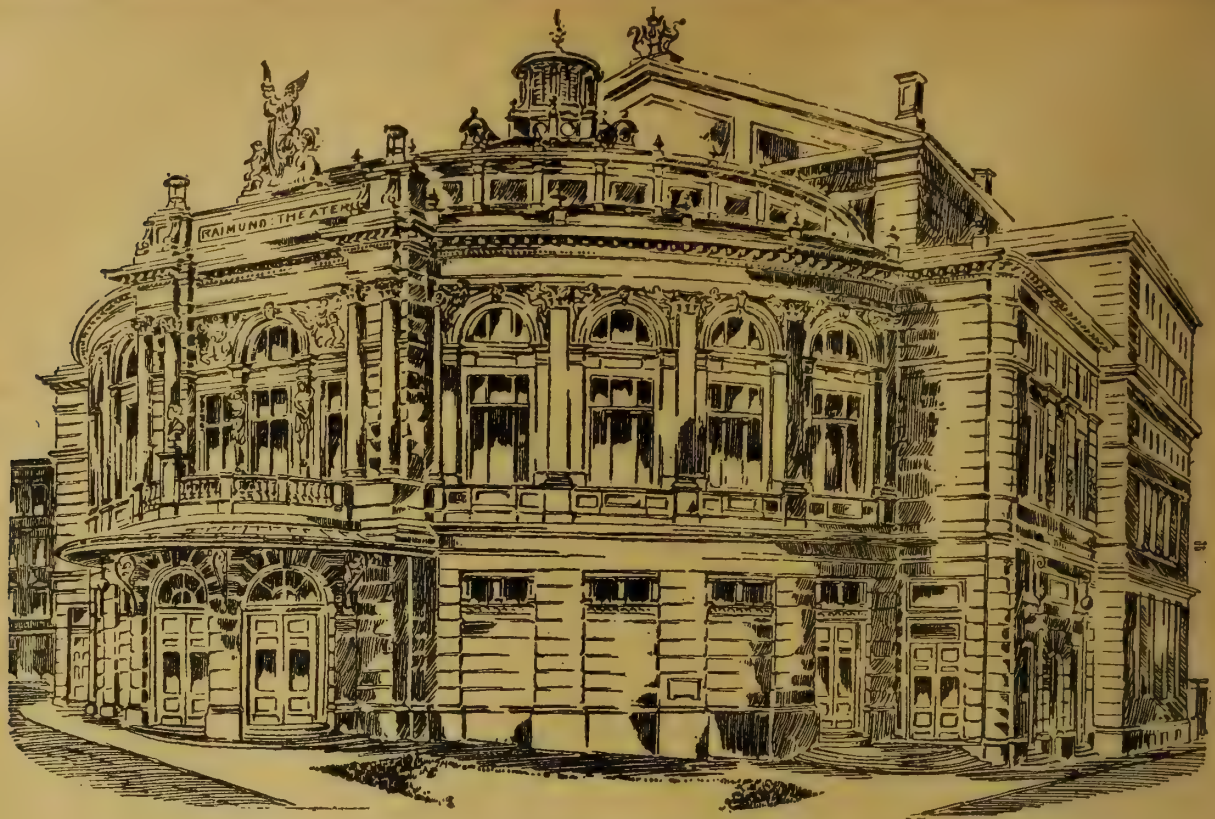

RAIMUND THEATRE, VIENNA.

found a most complicated financial basis, where questions of option, of mortgage, and the like predominated. The same held good for our provincial centres, with the one exception, that of the Memorial Theatre at Stratford-on-Avon, which had a special building fund, voluntarily subscribed, with the view of erecting a monument to Shakespeare. A like state of affairs also existed in our Colonies, and, with one or two exceptions, in the United States.

#### CONTINENTAL THEATRES.

But on the Continent we found a very different state of things. Among Latin countries in the South of Europe the private theatre was met with to a considerable extent. We also found the private theatre in large capitals of the Teutonic countries in Northern Europe. We, further, had the private theatre, which was subsidised by the State or otherwise, notably in Paris and Northern Italy. The private theatre, however, he argued, was not the typical home of the drama for the Continent. Principally the Municipal, the subscription, or endowed theatres prevailed, and also, to a certain extent, court and national theatres. Commencing with the Municipal theatre, Mr. Sachs pointed out that its object was generally educational and recreative, the low price of admission enabling all classes to witness the performance. Beyond the original outlay on the building, the ratepayers either allowed some annual vote towards maintenance, or they simply guaranteed to meet any deficit, should there be one. It was merely a question of good stage management and the pricing of admission; for, as there were no profits to be made, the plays were practically presented at cost price. Next, the subscription theatre was a gift presented to the town, sometimes by one or more of their wealthy citizens, at other times by a large section of the community, who voluntarily desired to participate in providing the city with a suitable playhouse, and who contribute from a few pence to some thousand pounds, according to their respective circumstances. Finally, the endowed theatre was shown to be an institution for which land and building were presented, together with a sufficient sum put in trust to cover the maintenance of the block, and any reasonable deficit on the productions. It is the *bond-fide* endowed theatre of this description that rightly ranked with some of those generous gifts of endowed picture galleries, public libraries, and artisans' dwellings for which this country was distinguished. The most recent form of the subscription theatre was the "People's" Playhouse,

voluntarily subscribed for by every class of the community, and conducted on co-operative lines, while a particular form of the endowed institution was the playhouse which had been provided for on philanthropic lines for the entertainment and elevation of the working-classes in the same way as many of our free libraries were established. Now, each of these—the municipal theatre, the subscription theatre, and the endowed theatre—was essentially a public institution. The standard of its founders was a high one, and where this was the case it followed that the conception and rendering of both interior and exterior—in other words, the architectural lines—ought to attain an equally high standard. The municipal theatre practically always stood as a monument to the prosperity and culture of a locality, and the architecture of the subscription theatre was intended to give a similar impression. It was further shown that national, Government, and Court theatres were primarily luxuries not so much intended to afford suitable homes for the drama as to serve as places of entertainment and ceremony for monarchs or state officials. Being the outcome of luxury, however, these buildings frequently became veritable palaces of luxury, for nowhere was the play more sumptuously housed than in these establishments.

#### THEATRE DESIGN.

Mr. Sachs then referred to the circumstances which governed the design of a theatre, and explained how, in the private theatre, we had only a problem of economy to solve, and the only regard that had to be given to the architectural rendering was whether the individual holder or lessee considered that his audience required a little more gilt, a little more York stone, art in its best meaning, a semblance of art, or the gaudy treatment of an advertisement. A few managers, though risking their money, had thought of the suitable housing of the drama, independently of the absolute restrictions of £ s. d. Sir Henry Irving was an exception when he first put the old Lyceum in order in 1878. As a rule, the architectural merit of the playhouse was considered a matter of minor importance, as long as there was the customary supply of velvet and gilding in the auditorium. The London manager and his provincial colleague had only to cater for the pleasure of a sensation seeker practically devoid of any feeling for architecture, and with little reverence for dramatic art. The British public cared very little for architecture. It was otherwise outside our isles. With a genuine reverence for dramatic art, there was also on the

Continent a genuine interest in architectural work, with the result that the play mostly found a worthy home amid appropriate and dignified surroundings.

#### THE THEATRE ARCHITECT.

The London playhouse was generally placed in the hands of architects who were merely good planners, good constructors, and business men, with a qualification of being able to provide for a maximum audience at a minimum outlay. With but few exceptions, it was of little importance if the so-called theatrical architect had the true feeling of art, if only he could secure the latest trick of the plaster manufacturer to catch popular taste. What counted more than any repute for architectural design was that the architect should have the talents and facilities of a financial agent, and be able to find money for the enterprise. The late Mr. Phipps told the lecturer that he would have frightened away his clients if he had spoken of architecture with a big "A." They would have thought him expensive, a faddist, or anything else but what they wanted. He purposely avoided trying even to make his façades or decorations presentable, for fear of being thought an art architect, and losing his theatrical *clientèle*. Of the many private playhouses that he designed, Her Majesty's theatre was the only one where there was any serious attempt made at architecture, and this was mainly due to Mr. Tree having indicated that he wished to have something above the commonplace. Of private theatres by other so-called "theatrical architects," the lecturer did not know of any that could boast of architectural pretensions. At present, the only theatre that deserved serious attention on account of its rendering was a small one at Cambridge, the work of Mr. Ernest Rüntz. The same architect's new playhouse at Peckham promised, however, to show an architectural rendering of a much higher order. His variety theatres, by the bye, showed yet better work. Mr. Darbyshire, of Manchester, had also conceived some excellent plans, on true art lines, in connection with the variety theatre, and Messrs. Colcutt, D'Oyly Carte, and Holloway similarly did excellent work at what was now the Palace Theatre of Varieties. Abroad, the architect of a playhouse had to be an architect in the very highest sense of the term. Where a municipal monument, the gift of a subscriber, or a Court or Government theatre had to be dealt with, it was only natural that every effort should be made to obtain a good building, and even in the private theatre the necessity for

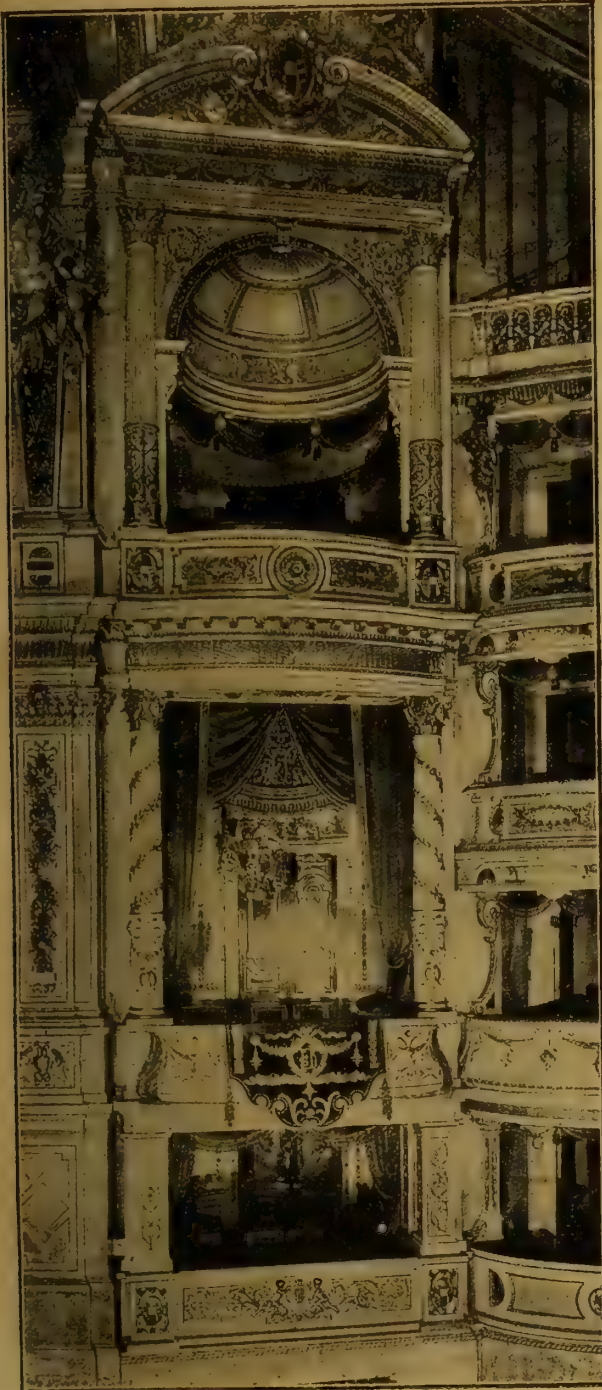

PROSCENIUM BOX, COURT THEATRE, VIENNA.



DETAIL, PARIS OPERA HOUSE.

catering for people who took an interest in architecture and respected the drama compelled the architect to be something more than a mere constructor. There was, in fact, no class of architectural work which put forward more numerous, complex, and essentially technical demands, and required at the same time that the rendering should not fall below the highest standard of taste, than that of the theatre.

EXAMPLES OF PRIVATE THEATRES.

Views and drawings of a very large number of theatres were shown and described with the object of illustrating Mr. Sachs's arguments. The collection embraced playhouses from all parts of Europe, including Russia, Scandinavia, Roumania, and other countries not popularly associated with the drama. The great superiority of design in the Court, national, municipal, and subscription theatres was indicated, particular emphasis being laid on the fact that of our own playhouses the Shakespeare Memorial was one of the few exceptions where considerable architectural merit was observable, and this was practically an instance of a subscription theatre. In London the late Mr. C. J. Phipps's Her Majesty's Theatre stood head and shoulders above the other West-End playhouses, Daly's came

next, then followed several somewhat above the average, like the Duke of York's Theatre, and the Shaftesbury, and the Lyric; but none of these could be confused with a suitable home for the drama. If they glanced round the suburban theatres, they found a similar state of affairs. Turning next to the Continental playhouses built under almost identical conditions—i.e., those of a financial enterprise, with the one exception that the general public demanded that the play should be suitably housed and had some interest in architecture. In conception, in outline, and in planning some of these buildings took a very high position, and even in their architectural treatment merited considerable attention. The Lessing Theatre at Berlin was an excellent example of a private playhouse; but in every private institution it was evident that the architect had been cramped, even where the excellence of his intentions was obvious.

MUNICIPAL, SUBSCRIPTION, AND ENDOWED THEATRES.

The author next dealt in detail with examples of this class of playhouse, remarking that the only subscription theatre in this country was the one at Stratford-on-Avon, built at a cost of £20,000, where every possible care had been

taken to invest a building with due dignity, and with due regard to its association. On the same basis we found so many interesting playhouses abroad, among which he had singled out Heinrich Seeling's three municipal theatres at Halle, Bromberg, and Rostock, the small municipal theatres of Salzburg in Austria, erected by Messrs. Fellner and Helmer, and their municipal theatre in Zurich. In these and in the subscription theatres they saw that freedom from monetary anxieties, reverence for the drama, and the demand on the part of the general public for the suitable housing of that art, as well as for good architecture, resulted in playhouses which fulfilled both ideal and practical requirements in every way.

COURT AND GOVERNMENT THEATRES.

It is among the court theatres that we had the most magnificent home of the drama extant. The Vienna Court Theatre, better known as the Hofburg, took the leading place among all dramatic houses. It was the greatest monument that has ever been erected in this direction. Erected at a cost of nearly £350,000, it was planned to hold an audience of 1,475 persons. It could be entered for the low price of sixpence. As an example of technical skill brought to high perfection, it was

the foremost home of the drama that had yet been created, both from the artist's, the architect's, and the actor's point of view. The structure was the outcome of the combined efforts of Gottfried Semper and Baron Hasenauer. The plan and the general lines of the design embodied the results of Semper's long study on the question of so-called radial planning, whilst the decoration and equipment gave expression to that wonderful delight in characteristic detail and ornament in which Baron Hasenauer excelled. Semper's experience at the Dresden theatres formed the stepping-stone for the general conception, and Baron Hasenauer's experience in the decoration of the great Vienna Court Museums also stood him in good stead. Apart from the ideal surroundings of this structure, which was situated on one of the most beautiful boulevards of the Austrian capital, it was the segmental treatment of the façade and its two wings which at once struck the eye, and gave this playhouse its individuality. The wings were due to the special requirements of the site and the desire to add to the importance of the block; but the segmental treatment was solely the outcome of the system of radial planning. The general grouping of the block was remarkable for the rational manner in which the exterior expressed every part of the interior arrangements. This characteristic was likewise very evident in the rendering of the principal façade. In the interior, the segmental foyer was certainly the chief feature, and the same formation was given to the grand vestibule and also to the minor lounge attached to the third and fourth tiers. As regarded the conception of the grand foyer, with its simple grouping of tiers of plasters, its exquisite colour study and decoration, it was impossible for him to say more than that, with the aid of brilliant workmanship, perfection had been very nearly achieved. He also called attention to the manner in which the two grand staircases rose from the street level to the first tier in one broad flight, and in the auditorium, again, alluded to the great prominence given to the Royal boxes in the proscenium, and the central State box. The careful and varied decoration of the box divisions was remarkable, and in the ceiling there was a skilful blending of semi-relief work with painted surfaces which had a note of originality. In its construction the building was remarkable for the extensive use of iron and steel in the containing walls of the auditorium, which were practically composed entirely of metal plates so fitted together that the intermediate spaces were used as ducts for ventilation and warming. Having also described the Paris Opera House, designed by M. Charles Garnier, and the Raimund Theatre at Vienna, the lecturer closed with an

#### APPEAL TO THE BENEVOLENT MILLIONAIRE.

He argued that we could not expect from the private theatre what the other classes of structure gave us, while our national institutions were such as to make it highly improbable that we should, within reasonable time, have either a Court theatre or a State theatre; and, with the few exceptions in our most go-ahead cities in the North, he considered it unlikely that we should even soon see the municipal theatre. He asked if it was not time to consider the question of subscription and endowed theatres seriously. Why, if we subscribed to the erection of picture galleries and the homes of other arts, could we not subscribe to the theatre? If we endowed museums and libraries, why could we not similarly endow the theatre? If we wished to erect monuments to mark the culture and prosperity of our times, why should they not take the form of playhouses? And if it was the universal desire that facilities for education should be given, why limit our gift to the collection and distribution of books, or the collection and presentation of art treasures? Calling attention to the many institutions by which England had become great, Mr. Sachs advocated that the citizen should take the initiative himself, and, either by subscription or through endowment by the wealthier members of the community, give us that high standard of playhouse which we should rightly long have had. He concluded by urging that the architect should advocate the subscription and endowed theatre as the only practical road at the present time towards the drama being suitably housed with due dignity and full regard to the possibilities of architectural design.

In opening a discussion on the paper, Mr. BERNARD SHAW said, speaking both as a dramatic critic and as a member of a London vestry, he

could see considerable and, indeed, almost insurmountable difficulties in the way of obtaining a municipal theatre. The multiplication of suburban theatres showed that private enterprise was taking good care of itself so far as the provision of houses for the drama was concerned. Nothing would, he believed, be expended upon theatres in England which were not directly remunerative, and he warmly sympathised with Mr. Sachs's endeavour to stimulate a demand for a better architectural treatment of the buildings.

Mr. WILLIAM ARCHER could not say he was entirely in sympathy with the author, but he felt that better surroundings for the drama would raise the general conception of the art. The drama suffered enormously from the fact that most of its temples were disguised as gin-palaces, or sandwiched in between them. He referred to the practical difficulties which beset subscription theatres, and protested against the supposed necessity for more Ibsenism in our theatres; while he was also certain that managers and actors could not live on Shakespeare or any other exclusive revival of old plays.

Mr. ALFRED DARBYSHIRE said that in Manchester some enthusiastic idiots, of whom he happened to be one, were endeavouring to take steps for the establishment of a municipal theatre. He paid a tribute of respect to the memory of Mr. C. J. Phipps, remarking that his best work was his last one, Her Majesty's Theatre.

Mr. CECIL RALEIGH humorously remarked that, as a working dramatic author, depending on royalties for a livelihood, he had been shocked to find that Mr. Sachs held up for admiration as the ideal theatre the Court at Vienna, which held an audience of less than 1,500, with sixpence as the rate of admission. He would ask what did it matter what the outside of a theatre—or, for the matter of that, the inside—was like? The play was the thing people went to see, and if they were only inclosed in four square brick walls, it would not matter a cent. to the spectators.

A vote of thanks to the lecturer was heartily accorded on the motion of Mr. E. A. GRUNING, seconded by Mr. THOMAS BLASHILL, and was acknowledged by Mr. Sachs.

#### THE ARCHITECTURAL ASSOCIATION.

THE seventh ordinary meeting for the present session of the Association was held on Friday evening, the President, Mr. Hampden W. Pratt, F.R.I.B.A., in the chair. Messrs. E. S. Curran, A. H. Longhurst, H. E. Sabej, and D. Stewart were elected as members. The President announced that the class of elementary physics would begin on Thursday, the 10th inst. (yesterday), and that for specifications and estimates on Friday, the 18th inst.

#### HAMPTON COURT.

A full and interesting paper on this palace, illustrated by a series of drawings and plans—some from the author's forthcoming work on the "Later Renaissance"—others executed by Mr. H. P. C. Maule\*, and to which the R.I.B.A. silver medal was awarded two years ago, also by plans of Wren's period, lent by H.M. Office of Works, and by some excellent lantern views, was read by Mr. JOHN BELCHER, F.R.I.B.A. The lecturer explained that he should treat his subject from the architectural standpoint, and then endeavour to trace the architectural developments found necessary to meet advanced requirements. Most palaces came under the category of "Public Buildings," but Hampton Court had the further distinction of being a combination of domestic and public building. Its beginnings probably imparted to it the homely character it still retained. Before it became a Royal palace there was a country mansion on the site, and to this Wolsey probably added his palace. It belonged after the Conquest to the De St. Valery family, who in 1217 handed it over to the Knights of St. John of Jerusalem. About three hundred years later, this estate, with the Manor House which had always been known as "Hampton Court," was leased for 99 years to Cardinal Wolsey, at a rent of £50 a year. From this time, its history as a palace commenced, and building operations on an extensive scale were proceeded with. But it is not very clear whether there was any architect, for such works were most frequently carried out by a combination of artists who worked together on traditional lines

\* These drawings were reproduced in the BUILDING NEWS for Oct. 9, Nov. 6 and 20, 1896.

in perfect harmony—the architect, the master mason, the master carpenter, and all the several artificers keeping within the limitations of their respective crafts. No doubt there was a leader or supervisor, whether called surveyor of works or clerks of works or (later) architect. He was "first amongst equals." Seventeen years later, when the work was carried on by Henry VIII., there were two names mentioned in the Hampton Court bills—Henry Williams, a priest, "Surveyor of Works" at Hampton Court, who would appear to have supervised all the details, and Eustace Mascall, who was "Clerk of Accounts." The latter was sometimes spoken of as the "Clerk of the Works," and was also clerk of the works under the Cardinal for his college at Oxford, where the details were similar to those at Hampton Court. These titles were still kept up at Hampton Court—there were still the "Clerk of the Works," the "Master Mason," the "Master Carpenter," and so on. These and the traditional methods had been passed down from the 16th century without any break. Mr. Law, the able historian of Hampton Court, had found, after an examination of the carefully preserved accounts for the several works during the reign of Henry VIII., that the workmen were all Englishmen. Mr. Belcher pointed out, however, that both Wolsey and Henry VIII. had part in bringing about the Renaissance; they both imported Italian workmen, and they both employed them at Hampton Court on decorative work. These foreigners were not builders, but only carvers and decorators, and we could trace their influence in the work of the Englishmen. Another example is in the plaque containing Wolsey's arms,\* also in terracotta. These and the roundels had well-developed Renaissance details, which were evidently not regarded as in any way incongruous by Wolsey or Henry VIII. On the other hand, the great pendants of the hammer-beam roof of the Great Hall, which were Italian in character and feeling, were the work of a Londoner, Richard Ridgo, who had come under the refining influence of the Renaissance. It was not improbable that the old Manor House, which he found on the site, was incorporated by Wolsey in his new building, but no trace of this was left. Wolsey's palace was evidently quite up to date in its arrangements and appointments. It was natural that the plan should partake of the collegiate quadrangular form. Yet on the west front there was a new departure, for at the western entrance two projecting wings formed a three-sided court, each wing, however, containing smaller internal courts. Hampton Court soon became a Royal palace, and from Henry VIII. to George IV. alterations and additions were in frequent progress. Those made by Henry VIII. considerably added to its attractiveness and importance. His work consisted largely in decorating and beautifying the existing structure and in remodelling certain parts to make these suitable to the Royal requirements. He affixed the Royal Arms and added badges and heraldic devices to the buildings. Parapets and pinnacles were added, and the whole building "restored" quite in the modern manner. It was this treatment which increased the enjoyment of the archaeologists, who were apt to look coldly upon the subsequent additions by Sir C. Wren, about which no mistake could be made, and where there was nothing to argue about on the score of date. Perhaps the first thing that strikes us in the earlier work of the Tudor period is, Mr. Belcher continued, the beautiful colour effects, partly due to age and atmosphere, but partly also to deliberate design. No doubt it was convenient to use local materials as far as practicable. The bricks came from Brouxham, Taplow, and other adjacent localities. Some of the stone came from quarries in Reigate, Barrington, and similar places; but Caen stone was also used where these were unsuitable. The oak was brought in large quantities from Dorking, Holmwood, Leatherhead, Banstead, Berewood, and St. John's Wood. With regard to the external effects, the beautiful texture was obtained by the inequality of the bricks, and the use of vitrified bricks in squares and lozenges. It is this which imparts to the whole that purple tone which is so admired. I am inclined to believe that Henry VIII. did not rebuild Wolsey's Hall, as has been thought; but that he merely put on a new roof or otherwise finished it. The use of chimneys, especially of shafts or terminals, was recent, and attention was drawn

\* Illustrated in the BUILDING NEWS for Aug. 16, 1897.



to this aristocratic novelty by the elaborate and varied treatment of the shafts. It is this frank treatment of a new feature or requirement which we do well to note. Its purpose is recognised, while it is used as a decorative feature. Most, if not all, of these cut brick chimney terminals have had to be rebuilt, and pipes have been introduced to make them more operative. As a picturesque feature they are so successful that they have been imitated, though not rivalled, during the Gothic revival, whereas the men of the Later Renaissance, such as Wren, discarded the separated shafts for the practical reason that by grouping or combining several flues in a square mass they gained in effectiveness. In the "Clock Court" are the entrances to the Royal apartments. Opposite to the Clock Tower is the entrance to the Queen's Great Staircase. This has been disfigured by some Gothic revivalist in the reign of George II., who has somewhat needlessly affixed the date 1732 to his work. On the south side is the entrance to the King's Great Staircase, and here we have our first taste of the Later Renaissance work. The magnificence of that colonnade in scale and proportion impresses us at once. It is the exquisite proportion, the subtle setting out of the spaces, which entrances the beholder. That trick of coupling the columns, which Wren learnt of Bernini in Paris, and which he employed at Chelsea and Greenwich Hospitals, is effectively made use of here. But instead of what is known as "Wren's favourite Doric," just look at those Ionic caps! You must go and sketch them carefully to appreciate them. The irregular setting out of the ceiling is the only thing I have never quite liked. Standing in this court you can take in the condition and progress of architecture from Wolsey's time in 1514 to George II.'s in 1732. If at Hampton Court the transition to the Renaissance may seem sudden, we have to remember that no structural additions of any importance were made from Henry VIII.'s time until William and Mary's reign—i.e., 1530 to 1690. Only in the internal fittings and decorations is there any indication of the Early Renaissance. Little was done in Elizabeth's reign, except in the garden; only a few rain-water heads have her initials on them, and these are decidedly Renaissance in character. In James I.'s reign, Inigo Jones was appointed surveyor in 1615, but I cannot discover any work of his in existence. His time was probably taken up in arranging the masques in the Great Hall for the Queen, and his imagination was exercised in wonderful architectural vistas and scenic effects. It was fortunate for William and Mary that with the occasion for additions, there was the man at hand. Wren was set to work, and fortunately for him there was no society for the preservation of ancient buildings in his time, and not being a sentimental person, and having no great sympathy for Tudor work, or for that part of it which was irregular and broken up, he did away with the irregular and inconvenient south and east fronts. Wren's plan was determined by the long canal on the east side. A centre line drawn from this to a point cutting the lines of the converging avenues would, to the mathematically-minded Wren, give the centre and building line of the new front, and this front would be at right angles with the centre line. Behind these fronts was an old court, called "Cloyster Green Court." The position of this court could not be altered by Wren in his reconstruction, and he therefore built on the old lines the new court known as Fountain Court, without reference to the centres of the new south and east fronts. The court is 116ft. 10in. on the north and south sides. The east side is 110ft. lin., but the west is 11ft. lin. shorter. This arises, as we may gather from the plans, in effecting a junction with the old and irregular walls. These works, commenced in 1689, were left unfinished at the death of Queen Mary in 1694, and little further was done until 1698, when the destruction of the palace at Whitehall by fire determined the King to complete his palace at Hampton Court. From Wren's estimate for "Finishing Part of Hampton Court," dated April 28, 1699, we gather that the east and south sides were externally completed, and the upper rooms, but that the State rooms and staircases were not. But the King contemplated further extensions, and there is a plan, belonging to H.M.'s Office of Works, showing what had been a part of Wren's scheme from the first—the formation of a new and grand approach on the north side. Such new entrance was to be made commensurate with the

grandeur of the new buildings then in hand. Its stateliness was to be enhanced by a 60ft. drive through the park, a mile in length. And in contrast to the straight piece of water on the east side, a circular basin of water, 400ft. in diameter, 5ft. deep, was to be formed at the palace end of the avenue, which at this point widened out so as to embrace a view of the whole palace. The chestnut avenue in Bushey Park and the Diana Basin are the only parts of this great scheme which were carried out. Like many another scheme of Wren's, it was set aside. In carrying out the work at Hampton Court, Wren was hampered for want of funds. As the work proceeded, the funds ran short, and the Portland stone he loved was not forthcoming, so that he was compelled to use Bath stone dressings in many places—for instance, in the Fountain Court windows and on the south front. The upper range of windows on the east side of the court have all been renewed in Portland stone during the last few years. Sir John Taylor, in whose excellent hands the care of the structure is now placed, is also at work on the south front. To such a strait was Wren reduced that, until a few years ago, the central part of the south front was in cement. Now it is in Portland, as originally intended. The work at Hampton Court may be said to be after the Dutch manner. It is lighter and less severe in treatment than many of Wren's other works, though without any loss of dignity or of monumental effect. Through it all, however, he has retained the English tradition. Whatever he assimilated he beautified. Mr. Maule, who has kindly lent the beautiful drawings and studies he has made of Hampton Court, has pointed out a curious, and, to me, unaccountable, difference on the east front. On the south-east angle there are twelve stone quoins, and only eleven on the north-east corner. You will see this on Wren's original elevation, so it would appear to be intentional. There are other variations. The width of the windows does not always correspond on the outside and on the inside, as you will find in the rooms at the south-east corner. They are divided into four divisions by sash-bars, but inside there are only three divisions. Here Wren sought to reconcile the need for uniformity in the exterior with that for proportion in the interior. Mr. Law severely criticises the pediment on the east front as being more or less a sham; but his opinion as to what Wren should have done I do not think will commend itself to an architect. He considers the pediment should rise above the balustrade, and stand out with only the sky as a background! No; Wren was quite right, and I might cite numerous good examples of this decorative treatment. The carving on the pediment of the east front is by Caius Gabriel Cibber, and represents "The Triumph of Hercules over Envy." The master carver was Grinling Gibbons; but he was not a figure sculptor. Grinling Gibbons is responsible for the rest of the carving, though William Emmett did some of it. Gibbons was excellent as a wood-carver; but these heads and keystones on the arches of the ground-floor windows in stone are so undercut, especially those with the initials of William and Mary in monogram, that most of the latter, at least, have had to be recarved—and, what is somewhat unusual, they have been quite as well done as the original. Beautiful as they are, however, the material has not been recognised, but has been treated as wood. There were originally metal figures above the columns on the south front; but these were removed to Windsor by George IV. Lately two figures have been sent from Windsor by the Queen to occupy what is said to have been their old position against the central piers on the south front. The stone pedestals are there, and the figures appear to fit them. They represent Hercules and Mars. These figures are found reproduced on a small scale as supporting the firedogs in one of the fireplaces of the State apartment. Mr. Law has brought to light the important fact that the ironwork of Hampton Court was designed by Jean Tijou, a Frenchman. It was carried out in England, and Huntington Shaw, who has hitherto enjoyed the sole credit, most probably worked on it. Passing through the King's Guard Chamber, we can only stop to notice the carved architraves and beautiful panelling in Norway oak, with garlands in limewood by Gibbons, and the large panels of excellent detail and proportions, which are characteristic of Wren's work. The chimney-pieces have bold and varying architraves. The

King's rooms, which occupy the south block, lead one into the other. The Queen's apartments are on the eastern side, which is in the principal front. The Queen's Gallery is hung with tapestry, which looks remarkably clean and new. This tapestry was discovered thirty-five years ago by the present courteous superintendent at Hampton Court, Mr. W. H. Pleasants. A picture having been removed, a defect in the woodwork behind made it apparent that some material was at the back like tapestry. Mr. Pleasants reported his suspicion to Lord Mount Temple, who at once sent word that he would make an inspection of the Palace, and that some of the woodwork was to be removed. The woodwork was removed, and although dust and cobwebs abounded, the tapestry was in good order, and, after a good brushing, it looks now as fresh as ever. It may have been covered up by Queen Caroline in 1735, for in Hervey's memoirs it is stated that she (the Queen) was very fond of pictures, and brought a number from Kensington Palace. The private rooms are interesting. The private chapel, being without external windows, is lighted by a pretty dome. The public dining-rooms, the Queen's private rooms in the rear, and the Presence Chamber and Guard Chamber were only finished in the reign of George II. The details of the large rooms are rather coarse and lacking the refinement which is to be found in Wren's work. Mr. Law demonstrates that it is the work of Kent. If we draw a centre line through the Chapel, pew, and Great Hall, we can see that they have been planned in relation to each other. Unless Henry VIII. destroyed Wolsey's Chapel, &c., as well as the Great Hall, this is additional evidence that the Hall was not enlarged by him. The Chapel was refitted and altered by Wren, and its carving by Gibbons and inlaid wood reared reminds us of Trinity Chapel, Oxford. The kitchens are well worth a visit. Notice the double arches over the chimney openings, the single keystone serving for the relieving arch as well as the stone arch under with its joggle joints. In conclusion, Mr. Belcher observed: In Hampton Court the student has a great storehouse of architectural treasures. Let me advise you to make separate studies of the chimney-pieces, the fire-backs, and fire-dogs, the old furniture, consisting of bedsteads, chairs, curtains, and needlework, old card-tables, and a perfect collection of silvered looking-glasses and old china. Then there is the ironwork, wrought and cast, which is a subject worthy of special notice. And, further, the gardens, with their inclosing walls, piers, gates, steps, and terraces, might form the subjects of many papers. All these treasures are so accessible, and sketching orders so easily obtained, that Hampton Court should long remain a prolific mine to the student. A short discussion followed, in which Messrs. ERNEST LAW, H. H. STATHAM, W. H. SETH-SMITH, PERCY HUNTER, and the PRESIDENT took part, and a vote of thanks was accorded Mr. Belcher.

#### SURVEYORS AS ARBITRATORS.

AT the ordinary general meeting of the Surveyors' Institution held on Monday evening last, the discussion was resumed on Mr. A. A. Hudson's paper, read at the last meeting, and bearing the above title (see our issue of the 28th ult., p. 123), by Mr. P. E. Pilditch, who thought that Mr. Hudson might well have extended the title of his paper, for there were many cases other than building ones which came before surveyors as arbitrators; for instance, that large class of cases in which the valuation of property other than buildings was concerned. Under the Building Act there arose a class of cases in connection with party-wall disputes, for which a very simple procedure was laid down, and one which answered, he thought, all the four requirements which Mr. Hudson had mentioned as prominent in the minds of litigants. A surveyor acted on each side, and a third was nominated to settle any differences between them which might arise. The were also the large number of cases (to which Mr. Hudson in his modesty had not referred) which were simply, economically, and satisfactorily settled by the Tribunal of Appeal created by the Act of 1894. The scale of costs authorised by the Tribunal were certainly most moderate, and cases coming before it need not, unless the litigants chose to employ counsel and solicitors, involve any very great expense. Four desiderata were laid down by the author as those to which litigants attached importance.

They were, briefly: An intelligent understanding of their case by the Tribunal trying it; next, strict legal rights, then prompt hearing, and, lastly, economy. Bearing in mind these points, it seemed that a building case could best be settled by an arbitration before a surveyor who was also an architect.

Mr. T. Rickman said he could hardly agree with the author's view of the question under discussion. He thought he had hardly laid sufficient stress on the importance of an arbitrator having the fullest possible opportunity of inspecting the work, and the necessity that the Court should sit within a reasonable distance of the building which was the matter of arbitration. He was not quite sure whether the author had made it clear that the R.I.B.A. conditions stipulated that the arbitrator to be nominated by the president should be a Fellow (and not merely a member) of that body. The arguments in favour of the architect of a building being the sole arbitrator in case of dispute arising were cogent, although there were cases in which an independent arbitrator should be a man accustomed to act for one side or the other in the matter of a contract; but building surveyors were so used to acting sometimes for one party and sometimes for the other, that he thought they might well be relied on to judge fairly in any dispute submitted to them. He did not think it quite fair that where, by the terms of a contract, certain matters were left to the decision of an arbitrator, the owner should have power to nominate him after the dispute arose. The arbitrator's name should be inserted in the contract before it was signed. With reference to accounts, in the old days, when a builder made out his own estimates, it was his business to make out his own costs; but the quantities were now almost invariably supplied to the builder, who tendered for each item at a particular price, and added the quantity surveyor's fees. Where there had been omissions and substituted extras, the charge for valuing them should be added to the amount in fairness to the contractor. A Technical Court such as had been proposed would, he imagined, have to decide cases of dispute as to the value of work done, and of intermixed property and party-walls. The London Building Act of 1894 had rendered the settlement of some of these matters much easier; but in the country there was still much difficulty in deciding them. How the ideal court should be constituted he was not sure, or what should be its powers of inspection or of calling evidence. His own view was that in building disputes the building itself was the principal witness, and parole evidence was only useful to explain the circumstances.

Mr. H. Northcroft was of opinion that it did not so much matter whether an arbitrator were a surveyor or an architect, so long as he was a strong man, and well acquainted with the technical matters in dispute. He supposed that three-fourths of the building disputes in the country came before arbitrators for decision; but the remaining fourth kept the Courts well supplied with business. A trial of a professional case before a judge was, to a professional man, a hopeless matter. Everyone concerned was ignorant, in the nature of things, of the technical details, and the result often depended on a mere side issue. Every surveyor who had experience of technical cases before the Courts would heartily agree with Mr. Hudson's proposal for the establishment of a professional tribunal, which should, he thought, not confine its jurisdiction to London, where the Building Act fairly provided for such matters, but should take cognisance of building disputes throughout the country.

Mr. A. Vernon said he did not know of any tribunal which had more satisfactory methods of settling points of law and of fact than the High Court; but, in dealing with technical matters, the judges were necessarily at a disadvantage. There could not be insuperable difficulties in the way of establishing a satisfactory system of arbitration in professional cases. The question of costs had been mentioned, and it was possible that these were often not much more satisfactory in an arbitration case than if the matter had been before the Courts.

Mr. W. H. Strudwick said he thought that for the settlement of building questions the mode at present in vogue was as satisfactory as any that could be suggested, and he quite agreed that a surveyor who, in the course of his ordinary business, was accustomed to act first on one side and then on another, was the most suitable person to select for an umpire.

Mr. C. J. Mann said that, while he agreed that an umpire might attach weight to the evidence of witnesses in proportion to what he knew of their experience and practice, he believed that every umpire would most carefully consider the facts as stated in evidence as the true basis of his decision. If, as he understood Mr. Hudson to say, the only power which the High Court had in cases involving accounts was to refer the action to an official referee; the matter was on a rather unsatisfactory basis. It would seem to be much better that the Court should be able to refer to an arbitrator or a technical tribunal. He was afraid that cases were now very often decided on a side issue; witnesses finding it very difficult to bring out important points when once the referee and counsel on both sides had got hold of what seemed to them a test point. He, of course, spoke with all respect. If an arbitrator could be named in a contract before it was signed, many disputes would be settled.

Mr. H. T. Steward said that no doubt the best way of settling building disputes was to bring them before a professional man as arbitrator—whether with or without counsel must depend on the nature of each case. In disputes under contracts with the Office of Works it was specially agreed that there should be no counsel employed in the arbitration. Of course, if points of law arose, it was advisable that counsel should appear. He was sorry to say that he must endorse the statement that counsel did sometimes add to the time occupied in an arbitration. He, when acting as arbitrator, rather preferred to have counsel present, for they were in the habit of arguing points without developing any undue heat, which the litigants themselves were not always capable of doing. He was pleased to notice, in many contracts with which he had to do, that the president of that institution was appointed to nominate an umpire in case of dispute.

Mr. Arnold Statham said that one of the difficulties to be faced by surveyors acting as arbitrators was that they had often been employed in other cases by one party or the other to the dispute brought before them to arbitrate upon; but he was glad to believe that in such cases they did their utmost to preserve an unbiassed mind, and he was sure that no member would accept a reference where there could be any suggestion of doubt as to his impartiality. Mr. Statham went on to quote a case where an umpire, acting for a railway company in one case, was held not to be biassed in deciding another case to which the same company was a party ("Haigh v. L.N.W.R.," 1896, 1 Q.B.) As to quantity surveyors, they were generally valuers, and the distinction between a valuer and an arbitrator could not be too clearly accentuated. As to allowing assistance to either side in a reference, it was generally better for the arbitrator to allow than to exclude any assistance that might be material. Such assistance had been held by the High Court to be allowable.

Mr. Hudson having replied on the whole discussion, and thanked the members for the patient way in which they had listened to his paper and the friendly criticisms which they had passed upon it, the chairman (Mr. Robert Vigers, vice-president) briefly summed up the discussion, and the meeting then adjourned.

#### THE SURVEYORS' INSTITUTION ANNUAL DINNER.

THE dinner of this admirable society was an unqualified success on Wednesday evening last, at the King's Hall, Holborn. Mr. Christopher Oakley, the able and ever-courteous President, was fittingly supported by the Earl of Jersey, Sir Richard Webster, the Attorney-General; Mr. Jesse Collings, M.P.; Judge Meadows White, Q.C.; Sir John Wolfe Barry, President of the Institute of Civil Engineers; Sir I. F. L. Rolleston, Mr. R. Vigers, Sir Ernest Clarke, Sir A. R. Binnie, Mr. A. Chancellor, the Mayor of Richmond, and many others well known in the legal, architectural, and surveying professions. The Royal Institute of British Architects was not, however, officially represented, and the President, Mr. George Aitchison, R.A., himself a leading district surveyor, was conspicuous by his absence. The following particulars were incorporated in the speech of Mr. Wheeler, Q.C., who proposed the toast of the evening, "Success to the Surveyors' Institution":—The institution was founded in 1868, and incorporated by Royal Charter in 1881. The

first ordinary general meeting of the institution was held in November, 1868. The society then numbered 150 Members and Associates. It now numbers about 3,000 of all classes, representing a growth from 150 to 3,000 in 30 years. In 1868 two gentlemen shared between them the honours of the students' class, and Mr. Wheeler stated that he himself was one of those two. There are now nearly 300 students on the roll. From the numerical standpoint the institution now occupies the second place among professional societies, omitting, of course, from this comparison those ancient corporations, the Law societies and the two branches of the medical profession. In the same 30 years the institution has endowed the profession with a literature comprising some 40 substantial volumes. It has introduced a system of professional examinations of a most practical character carefully adapted to the requirements of the various branches of the profession, and has actually examined 3,228 candidates in the last 16 years. It has accumulated funds sufficient for the construction of a handsome building, now in course of erection in Great George-street, at a cost of some £30,000, from designs by Mr. Alfred Waterhouse, R.A. The Institution has a large branch in Ireland, comprising all the leading land agents in that country, and another branch in Scotland. It possesses a valuable library of about 8,000 volumes, and various collections, including a forestry museum, for which ample accommodation will be provided in the new building, which was illustrated in the BUILDING NEWS for Jan. 1 and June 4, 1897.

#### ELECTRIC LIGHTING NOTES FOR ARCHITECTS.—XVI.

By AN ASSOC. INST. ELECT. ENGS.

WIRING (continued).

THE *Cleat System*.—In this system the conductors are supported by means of hardwood cleats, grooved, as shown in Fig. 44 I,

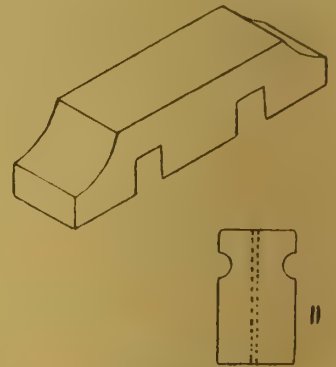

FIG. 44.

varying in length from 1½ in. to 6 in., and from ½ in. to ¾ in. in width, according to the conductors supported. These cleats are fastened to the walls or ceilings by means of a screw passing through the centre of the cleat. The cleats are placed about 1 ft. apart at a high level, and in running the circuits it is customary to strain the conductors like telegraph wires; and since the size of the grooves are such as will grip the conductor when the cleats are screwed up, there is no difficulty in keeping the wires stretched and in producing a neat appearance.

This system is more especially adaptable for temporary work, and for factories and workshops, although it is not recommended for permanent work in any case, as it is deficient in mechanical protection. As an example of open work it is inferior to the method shown in Fig. 44 II, in which a wire is shown secured from the wall by means of porcelain knobs or cleats. In some "fire rules" in which the cleat system is allowed, the rules state "that the continuous and permanent separation of the + and - conductors from each other must be secured by a space of at least 2 in., and from walls or the like by a space of at least ½ in., or by a porcelain or wood backing at least ¾ in. thick."

*Damp-proof, Fireproof, and Impenetrable Tubes Systems*.—The third system of supporting conductors includes a number of special systems, two of which demand more than passing notice, both on account of their specific characteristics and

the advance they make in the quality of the protection and insulation introduced. The first which we shall consider is known as the *conduit system*—has already been largely adopted in America and in Germany. This method of wiring originated with Mr. E. H. Johnson, who was connected with the Edison Companies of America, and consists essentially of a tube of insulating material through which the cables are afterwards drawn, and which displaces the

smooth, frictionless surface, over which conductors can be easily drawn, and thus makes possible any alteration or extension without fear of mutilating valuable decorations. A lined conduit can be guaranteed free from the internal "fins" and "burrs" incident to plain pipe-work, both before and after erection.

*Economy.*—Steel-armoured insulating-lined conduit provides absolute protection for the conductors, mechanical and electrical; immunity from fire risks: convenience for alteration and extension; and doubles the life, whilst greatly

cable being laid directly in the plaster, so that the outer conductor forming the return wire is completely earthed, and it is therefore evident that, by earthing this conductor, it is always at zero potential—i.e., earth potential—and there cannot be any risk whatever of shock or spark being experienced from it. A section of this cable is shown in Fig. 46, and as there is only one vulnerable conductor—and this, with its insulation, being incased throughout its entire length in the metallic sheathing formed by the outer conductor—it is well protected against injury.

In the case of the concentric conductor, if it should be crushed, or a nail be driven into it, the instantaneous result is a dead short-circuit, and the melting of the fuse. If the insulation should be punctured and moisture gain access, the distance across the insulation between the conductors is so small that the fault immediately develops into a short-circuit, and the spark passes from the centre conductor to the inner surface of the metallic sheathing, and being entirely within the sheathing, it cannot communicate fire to its surroundings. Concentric conductors are thus self-testing. Faults cannot endure. They cut themselves out automatically. Probably the most conspicuous advantage of concentric wiring is that it may be so easily and so effectually made waterproof. The cables may be inclosed in lead sheathing, laid under or over the outer conductor, and hermetically sealed to the various apparatus into which the cables are led. As this is a special system of wiring, special fittings and junction boxes have been designed. Whenever a joint is to be made, or the cable led into a switch or fitting base, the centre wire is soldered to its contacts, and the outer conductor and its lead sheathing are received and terminate in a jointing pocket cast upon the switch-box or junction. The central wire and its insulation are thus inclosed throughout their length in a hermetically-sealed metallic sheathing. The switches and fuses should be in the central wire and inclosed in the metal case.

As a means of showing the different systems of wiring, we give in Fig. 47, examples of the following:—

- (a) Wires secured on the surface by metal staples.
- (b) Wires directly imbedded in plaster.
- (c) Wires secured on surface by wood cleats.
- (d) Wires secured on surface within wood casings.
- (e) Wires secured on surface by means of porcelain knobs or cleats.
- (f) Conduit-wiring beneath surface with twin (concentric) conductors.
- (g) Armoured conduit wiring beneath surface with twin (parallel) conductors.

We may now compare wood-casing with the newer and special system. Wood-casing no doubt owes its extensive use to two desirable attributes—*ease with which it is installed* and *accessibility* (when not concealed). Compared with the newer systems of protecting cables, it is cheap, and lends itself fairly well for surface work. At the same time, the cost of labour in fixing the cables is greater, and as a mechanical protection for the wires it is imperfect; and it is as deficient in insulating protection, because it is neither fireproof nor damp-proof. It also expands, contracts, and warps, and may possibly cause the plaster to crack, and it is altogether unsuitable for use in damp places.

*Fittings.*—As an introduction to that part of our subject termed "fittings," we give here the good and bad points of some of the chief materials used as insulators. The bases and supports for switches and other fittings should possess high insulation properties, and it is essential that they should be non-combustible, not readily breakable, nor affected by atmospheric changes. Wood, porcelain, slate, marble, and red vulcanised fibre possess the following properties:—

*Wood* is easily worked, but is soon affected by moisture, and is liable to expand, contract, or warp. It is also combustible and readily chars, unless covered with some unflammable substance, in which case it may be used for the bases of cut-outs, although it is not recommended in any case. It is a fairly good insulator when thoroughly dry.

*Porcelain* is an excellent substance for bases, and is a thoroughly good insulator. It is, however, brittle, and if subjected to much strain is easily broken; consequently care is required in fixing porcelain bases. It is non-combustible.



FIG. 45.



FIG. 46.

wooder casing. A variety of materials have been used for making the tubes; but we shall only refer to those introduced by the Interior Conduit Company. The insulating material employed is a specially prepared hydrocarbon of the bitumen class. The necessary strength in tube form is obtained by using a peculiar grade of fireproof paper material which admits of impregnation. The result is that these tubes are very light, easily manipulated, smooth, damp-proof, fireproof, and very tough. This type is known as *plain tubing*, and there are two other varieties, the brass-covered and iron-armoured. These coverings give additional mechanical strength, and render them more impenetrable. In each of the three types the tubes are made in 10ft. lengths, and suitable couplings and junction-boxes have been designed for rendering the system as perfect as possible. The method of drawing the wires in is simple and interesting. "The wires or cords for drawing them in when required are drawn in by a fishing wire consisting of a narrow band of steel about 60ft. long, with brass balls at the ends, the interior of the tubes being lubricated by blowing in powdered soapstone. It is found that this lubrication, combined with the smoothness of the tube, affords complete immunity from the abrasion to which insulated wires are liable on being drawn into ordinary iron piping." A section of an insulated steel tube is shown in Fig. 45.

In connection with the use of iron pipes without interior insulation, it may be remarked that the tendency to rust inside tends to diminish the insulation of the cables, and that burrs and other internal roughnesses may cause serious mechanical damage to the insulating material as the wires are being drawn in. The following are the essential advantages claimed for the conduit system of wiring:—

*Durability.*—The insulating lining, being a non-conductor of heat, prevents any temperature changes from promoting internal condensation within, and deterioration of, the steel pipe. It preserves also the insulated conductors contained within the pipe, under the least changeable conditions, and is, therefore, conducive to their greatly-increased durability.

*Safety.*—The insulating lining provides smooth cushioning interior surface, which will not abrade the insulating covering on the conductors, and resisting the effect of an internal "arc," prevents danger from fire risk due to any "short-circuiting" or "fusion" of the conducting wires. The lining proves more trustworthy than "fuses," and provides a "safety factor" which no method of testing can insure. Also the insulating properties of these tubes is such as to provide (approximately) an additional "300 megohms per mile" insulation resistance to the wire. The bituminous material used in the insulating tubes is inert in its nature, and exercises no deleterious influence on the insulating material of the wires themselves.

*Convenience.*—The waterproof insulating lining being "steel-armoured," cannot be damaged, and therefore guarantees a certain standard of insulation resistance under all accidents of material or workmanship. The insulating conduit method of wiring provides a system of electrical installation analogous to that of gas or water, and checkmates the ignorance or carelessness of unskilled workmen.

*Accessibility.*—The insulating lining gives a

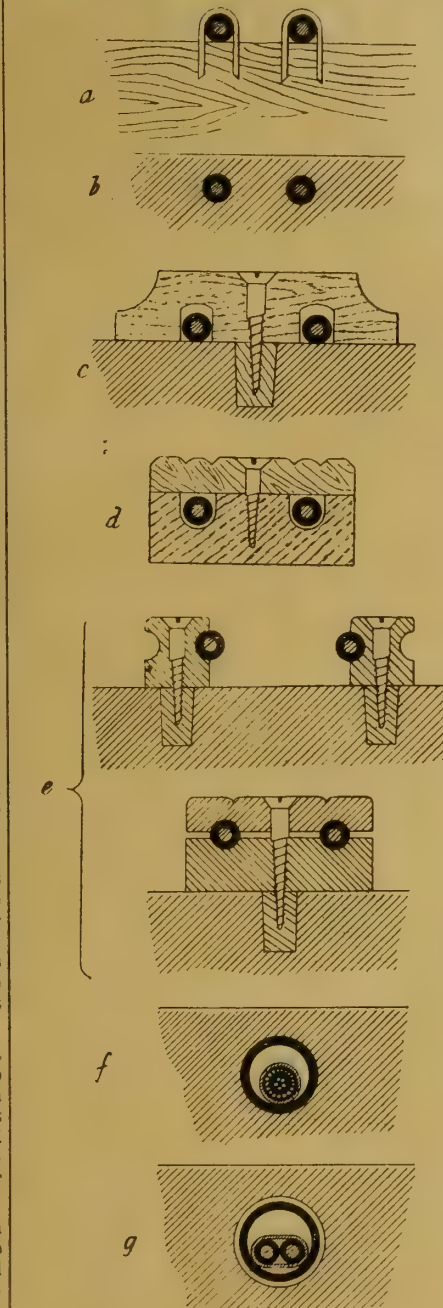

FIG. 47.

increasing the efficiency of the lighting system, with an increased cost of but 5 per cent. upon the total expenditure for complete installation.

The second system to which we must refer is that known as *concentric wiring*. Several varieties of this system have been introduced by different inventors; but we shall only deal with general principles. In this system of wiring a central conductor or strand of wires is thoroughly insulated by vulcanised indiarubber, which is everywhere surrounded by an uninsulated outer conductor or metallic sheathing of conductivity equal to or greater than that of the core. The inner conductor consists of copper wire or wires, whilst the outer, which has a much larger area than the inner, consists of galvanised iron wires, and forms the armouring of the cable. As in the conduit system, no casing is used, the armoured

*Slate* is a very good insulating substance, and is tougher than porcelain. Unless varnished, it is liable to absorb moisture, which diminishes its insulating qualities. It is non-combustible.

*Marble* is an excellent insulating substance and is tougher than slate, and is not liable to be affected by moisture. It is non-combustible.

*Red vulcanised fibre* is a very good insulating substance, and is specially adapted for insulating handles, being easily worked, mechanically strong, and tougher than wood. It is not brittle, and, although charred by fire, it is not inflammable, and, if varnished, is not affected by moisture. Its insulating qualities are somewhat diminished if subjected to variations of temperature.

#### STABLE FITTINGS.

**MESRS. HAYWARD BROTHERS AND ECKSTEIN**, Limited, of Union-street, Borough, London, S.E., have published a new catalogue of stable and cow-house fittings. The old-established "Cottams" fittings, so favourably known to stable-builders and architects, now made by this firm, have been supplemented by the addition of many improved patterns which experience has suggested. In looking through the illustrated catalogue on our desk, we notice several of these improved fittings. Some practical hints are given on the planning of stables, and suggestive plans for fittings are shown well worth the architect's attention. The cubic space per horse is given as 1,500ft., and the height should not be less than 12ft.; stalls 6ft. wide, and 9ft. or 9ft. 6in. from wall to outside of post. Loose-boxes should be about 12ft. by 10ft., with doors opening outwards. The stall divisions show a space below bottom rail for ventilation, with straight and curved ramp-rails. The stall division, for converting loose-box into two stalls, is a good arrangement. Several patterns of ventilating ramps of wrought-iron bars are illustrated. These have cast-iron heel-post 10ft. high, iron halter rings, guard-bar, bottom sill with shifting piece. The woodwork is 1½ in. to 2in., and the prices are moderate, and suit every stable. The loose-boxes illustrated show many improvements. We note a capital arrangement for ventilating stalls and loose-boxes by a patent ventilating iron sill, perforated, with the top flange formed with a groove for receiving the woodwork of division. Several pages are devoted to self-fixing cast-iron bases for heel-posts and manger sets. The new safety manger fittings of Messrs. Hayward Brothers and Eckstein are excellent; they avoid all sharp angles, the top plate is "barrel-fronted," there is a manger-pot, tip-up gruel-pot, hay-rack, patent silent tying apparatus, &c. We advise the profession to take note of these improved mangers and fittings which this company have introduced into the stables of Lord Dudley, Messrs. Maple and Co., Ltd., J. Andrews, and others. We recommend our readers to send for the catalogue.

#### A COAT OF PAINT.

A COAT of paint is an object familiar to all of us; but how few—even those persons who lay on a "coat" of paint—know much about the constitution or composition of such coat. Painters all their lives may have been laying on coats of paint on all sorts of materials, which have been subjected to all kinds of influences—heat, cold (internal and external), air, &c.; but, although the process of producing the "coat" is practically the same in all cases, the conditions of permanency, durability, or wearing qualities are materially affected by the conditions under which the paint is laid on, and by the nature of the material overlaid with such paint. In this and subsequent articles it is the writer's intention to expose the reactions that occur in a coat of paint. In a former article the vagaries of a paint were laid bare as regards the phenomenon technically known as the "sinking-in" of colours; in that article the chemical reactions producing this optical effect was given and advice also for the prevention of same. In the present article it is the writer's intention to consider the nature and cause of

#### BLEISTERING OF A PAINT.

And in subsequent articles to consider the cause of peeling, cracking, wearing away, &c., of a coat of paint. The primary operations are best detailed, so that a clear conception of what is to follow will be obtained. These preliminary

operations will, in a great measure, be controlled by the quality of the painting to be done. For the purpose of our present paper we will consider the question of painting a superior job on wood, one which has to be painted to perfection. The quality of the finished work depends on the preparatory work of laying on the priming coat. The first operation should consist in rubbing down the rough places in the wood by means of sand or glass-paper wrapped round a block of wood. For the mounding, a stick can be used, or the sandpaper rolled into a cylindrical form.

After smoothing the surface of the wood, carefully inspect it and remove all traces of resinous or gummy matter that exudes from the knots or cracks in the wood. If a long slit-like crack shows itself in the wood, scoop or scrape out any resinous matter and carefully fill in same with hard putty. It will be noticed that the knots are apparently full of resinous matter. This matter cannot be forced out of the knot, and although what is on the surface may be removed, that which is retained in the fibre by the knots will eventually come to the surface by the contortions caused by alterations of temperature to which the wood will be subjected, and as a consequence these later exudations of resinous matter will dislodge the paint that is laid over them, and either cause the paint to remain soft and sticky, or else cause it to peel off. Now the usual method to prevent disaster of this kind in the future is to lay over these knots a compound called "knotting." These knotting compounds usually consist of shellac varnish for best quality work (*vide infra*, for formula for preparing these knotting compounds), white or bleached shellac being used for wood that is to be painted in light colours or varnished, and orange or ruby (sometimes called black shellac) used for wood that is to be painted dark. In any case, the writer has found that the knotting will, in course of time, show itself in some undesirable form, either by causing the paint over it to shrink or shrivel up, exposing wide cracks or fissures in the paint, or else causing a discoloration in the paint or varnish itself by reason of the confined resinous matter in the paint, in its endeavours to exude from the surface of the paint, causing chemical and physical reactions with the knotting compound. Now the writer, from what attention he has given to this subject, has found that it is far better to extract all possible quantities of the resinous matter before laying on the knotting compound, than it is to imprison the resinous matter under a hard, unyielding, but brittle, coat of shellac. The resinous matter may be extracted by brushing the parts over with benzine repeatedly, or sulphuric ether; these fluids will penetrate the fibre of the knot and combine with the resinous matter contained therein, and by diluting the gummy matter allow it to come to the surface freely, and thus easily removed. The operation takes some little time; but by repeated application of these solvents all the free resinous matter may be removed, and then, when the "knotting" is laid over the knot, it will be on a hard solid surface, from which no exudation in future will occur. Another substance that will combine with the confined resinous matter is a strong solution of caustic soda, which will form a resinate (*i.e.*, resin soap) in the fibre of the knot, whereby the soft expanding resinous matter becomes converted into a solid, hard-drying body, which will not exude in the future. Formula for knotty compounds:—

No. 1.—Ingredients: 1 gallon of methylated spirit, 24oz. of amber resin powder, 56oz. of shellac.

No. 2.—Ingredients: (a) 87oz. of shellac, 30 fluid ounces of methylated spirit, 1 fluid ounce of water. Mix the spirit and water, after having dissolved the shellac in the spirit.

(b) Ingredients: 32oz. of Kauri copal powder, 3oz. of methylated spirit, 1oz. of turpentine. Dissolve by slow digestion.

For use, mix 3 parts of *b* with 1 part of *a*\*. After covering over the knots in the wood, the next step is to putty up all holes and cracks. If the painting is to be done in two coats only, the putty used should be composed of common whiting and white lead ground in oil, the mixture being prepared of the right consistency. To putty up nail-heads, it is best to apply the putty after laying on the first coat. If the painting is to be done in three coats, the putty used should be

\* The above is known as patent putty. The older form of such compound was composed of red-lead, litharge, and boiled oil or spirits of turpentine.

composed of linseed-oil and whiting—*i.e.*, pure linseed-oil putty, and the puttying should be done between laying on first and second coats. After allowing for the knotting to dry, the next step is to lay on the priming coat; this is generally white lead which has been just tinged with red lead to give the priming coat a pink hue. This priming coat is always laid on very thin (it is mixed of almost a fluid consistency), and after laying it on, the puttying is done. Instead of a pure white or a pink being used for a priming coat, it is better to tinge the colour of this coat with the same colour pigment as the finishing coat is to be. Thus, if green is to be the colour of the finished coat of paint, a small quantity of some green pigment should be mixed with the white-lead used in the priming coat, and it is a good practice to make the early coats darker than what the finished coat of paint is to be. This will give a solid appearance or "good-quality" finish to the painted surface. Where the coat of paint consists of three or four layers of paint, it is not an infrequent practice to colour the first or second one a slate grey by mixing lampblack with the white-lead. It is, however, better to use each coat of above similar to what the finishing one is to be. If by any means the previously laid-on coats become greasy, smoke-begrimed, or otherwise soiled, it should be sponged over with turpentine. This will remove the grease, and is better than soap, potash, or soda-and-water. These last bodies will remove the grease; but they will also partially unite with the oil in the paint, and convert some into a soap. Such soap will show itself by making the surface of the coat of paint slippery, and as a consequence the next coat of paint will not firmly adhere or combine with the previous one. Of course, in the case of repainting old work, this does not apply, as the oil in the old paint has become so hardened as to be unacted on by the alkali, and then soft soap or soda is the best body to use for cutting and removing the grease. The proportions of the ingredients of each part vary according to the nature of the pigment to be used. This is necessary because the chemical composition of pigments are very diverse, some being sulphides, others oxides, others carbonates, &c., and although oxides as a rule require less oil vehicle than most other pigments, yet the nature of even those of the same chemical classes are so different that no general hard-and-fast rule can be laid down for the proportions of oil and pigment when mixing into a paint. Thus, oxide of zinc is a very light amorphous powder, while oxide of lead is a very dense heavy one; and while the latter pigment readily combines with the oil used in grinding it up into a paint to form a homogeneous compound, yet excessive grinding of zinc oxide and oil will not cause them to combine in the manner lead oxide does. In small shops it would not pay to grind up one's own colours into paint, except by the aid of a hand-mill; but in large concerns, where an enormous amount of paint is used weekly, it would pay to do so, as then the user of the paint would be able to guard against fraudulent adulteration. The actual process of grinding up the dry pigment in the oil vehicle is done by first roughly mixing the pigment with sufficient oil to form it into a stiff paste or dough, and then put this through the mill with the remainder of the oil. The compound will require to be put through more than once—until, in fact, it is of the desired workable consistency.

The superficial area covered by any paint will depend on the nature of the paint, as some colours spread over a larger area than others when taken weight for weight, or bulk for bulk. In the following tables are given the approximate amount of each ingredient for compounding paint for first, second, third, and fourth coats to cover 100sq. yds.

In addition to these, there will be required for the same area 5lb. of putty, 2½ lb. of white-lead, and for exterior work exposed to the atmosphere, where only two coats of paint are required, 1 pint of turpentine and 4 pints of boiled oil should be given on both coats in excess of what is named in the table. When the paint is required to dry quickly, more turpentine than stated is required in all the coats. It should be mentioned that the estimated quantities in the table below are for freshly worked up pine; on other materials the superficial area might be larger or smaller, according to its roughness, porosity, &c. The area covered also depends on the state of the

weather when the paint is being laid on, whether warm or cold, wet or dry, or hot.

No. 1. For interior work not flatted. Priming coat: Red-lead, 1lb.; white-lead, 16lb.; driers, 1lb.; raw linseed oil, 6 pints. (More red-lead and less driers may be used.)

Second coat: White-lead, 15lb.; driers, 1lb.; raw linseed oil, 3½ pints; turpentine, 1½ pint.

Third coat: White-lead, 13lb.; driers, 1lb.; raw linseed oil, 2½ pints; turpentine, 1½ pint.

Fourth coat: White-lead, 13lb.; driers, 1lb.; raw linseed oil, 2½ pints; turpentine, 1½ pint.

INSIDE WORK AND FLATTING.

	1st coat.	2nd coat.	3rd coat.	4th coat.
Red-lead	1½lb.	12lb.	12lb.	12lb.
White-lead	16lb.	12lb.	12lb.	12lb.
Driers	2oz.	1/10 lb.	1/10 lb.	1/10 lb.
Raw linsd. oil	6 pints	4 pints	4 pints	4 pints
Turpentine	½ pint	1½	1½	1½

The flatting consists of 9lb. white-lead, 15lb. driers, 3½ pints of turpentine.

OUTSIDE WORK NOT FLATTED.

	1st coat.	2nd coat.	3rd coat.	4th coat.
Red-lead	2lb.	—	—	—
White-lead	18½lb.	15lb.	15lb.	15lb.
Driers	1½lb.	1/10 lb.	1/10 lb.	1/10 lb.
Raw linsd. oil	2 pints	2 pints	2 pints	3 pints
Turpentine	2 "	2 "	2 "	2 "
Boiled oil	2 "	2 "	2 "	2½ pints

APPROXIMATE QUANTITIES OF PIGMENTS FOR ORDINARY PAINTS.

Pigments in lbs.	Pigments in lbs.						
	White.	Black.	Green.	Red.	Umber-late.	Stone.	Lead Grey.
White-lead	100	...	...	...	...	...	...
Lampblack	...	100	...	...	...	...	...
White-lead	...	25	...	...	...	...	...
Verdigris	...	75	...	...	...	...	...
Red-lead	...	50	...	...	...	...	...
Red ochre	...	50	...	...	...	...	...
Lampblack	...	...	...	4	...	...	...
Spanish brown	...	...	...	96	...	...	...
Burnt ochre	...	...	...	1	...	...	...
White-lead	...	...	...	99	...	...	...
Lampblack	...	...	...	...	...	...	...
White lead.	...	...	...	...	...	...	93

The priming coat for walnut or dark colours is best prepared by using a mixture of Venetian red and lampblack ground up in boiled oil, and the compound used very thin, so as to stain, rather than paint, the wood. For mahogany, a priming of a paint composed of red ochre, stained with a little red-lead, may be used, while for oak, maple, and other light colours yellow ochre should be used. The object of using a dark priming, or one which is similar to the finished colour, is to avoid showing a white surface beneath the paint should it be scratched, chipped, or cracked.

After the priming coat is laid on and dry, fill up all indentations, nail-head holes, &c., with pure linseed-oil putty, and then smooth the surface by rubbing with fine sandpaper. This rubbing should be carried out with each coat when dry enough, before proceeding to lay on the next one. After the second coat is dry, inspect the work to see if there are any soft parts under the knotty compound. The third coat should not be put on until the second one is sufficiently dry, and the same remark applies to the fourth coat, and the last or finishing coat should not be at all soft or tacky if it is to be varnished. The varnishing should never be done in a moist or damp atmosphere, neither should a draught of cold air strike the varnish after laying it on, for if it does, the resins in the varnish will be more or less deposited, and show their presence by imparting a bloom or milky appearance to the varnish, or, in technical language, the varnish becomes chilled.

H. C. STANDAGE.

(To be concluded.)

The Stonehaven Harbour Board are contemplating making a considerable extension of the harbour area. The Loan Commissioners have offered to advance £13,000 on comparatively easy terms.

The docks committee of the Bristol Corporation have appointed Mr. Thomas A. Pearce, M.Sc., as chief assistant to the docks engineer, at a salary of £400 a year, and have raised the salary of Mr. H. C. Parkinson, mechanical engineering assistant engineer, from £250 to £300 a year.

"BUILDING NEWS" DESIGNING CLUB.

A SMALL PUBLIC LIBRARY.

THE Christmas holidays seem to have interfered with the work of the members of our Designing Club, unless it be that the problem of designing a Public Library on outline instructions proved too great a task for some of our usual contributors, seeing that some of the best of them are conspicuous by their absence on this occasion. We intentionally left the competition particulars somewhat vague as to the relative sizes and location of the several rooms, because it seemed to us best to give a wider scope to the designers, and, moreover, it appeared desirable in their own interest that they should study up the subject for themselves, and not always be fettered by too many leading-strings.

It cannot be said that any of the designs realise a model type to be followed. We did not expect the plans would do so, and we admit the apparent tiresomeness of criticism which sometimes is taken to be little better than fault-finding. If, however, we do find fault, our intention is not limited by any such narrowness of idea. Indeed, we wish to help the members to improve, and we always heartily welcome, therefore, any good points in their work. "Centaur," on the whole, is the best, "By Go" comes second; and the third position is taken by "Maggot," though we do not consider his design calls for illustration. The following are the conditions, which ought to be read somewhat carefully in judging as to how far the competitors have carried out the scheme therein indicated. Where a lead was necessary it was given, though such aids were by no means always acted upon.

"Third List of Subjects.—C. A Small Public Library for a suburban district, the site being a corner one in a main thoroughfare, with a frontage of 110ft. and a depth of 80ft. The return road is on the left-hand side of the frontage which faces north, and main façade is to be set back 5ft. A porch or bays may project. No rights of light can be obtained on the right hand of the site. The accommodation required is to comprise a large newsroom, a magazine room, a reference room, and a lending library, all on the ground floor. A ladies' room and a boys' room, as may be contrived, and a librarian's room is necessary. Upstairs, a flat for his accommodation is to be provided, befitting an educated man with a limited income and small family. A filing space and workroom for the staff is necessary, and in the basement a heating-chamber, and lavatory, &c., for staff. The problem is to properly appropriate the relative sizes ordinarily required for the respective departments in a library of this class, remembering that ample counter-space for the lending library is essential. Style left to the taste of designer. Cost, £5,000. Materials, red brick and stone. Scale, 8ft. to the inch for elevations and sections. Plans, 16ft. to the inch. A sketch view wanted."

"Centaur" is the best; but there is an absence of central control which in a small library such as this is a great fault, making extra supervision absolutely necessary. The librarian is too publicly placed, for he is not a janitor, and needs quiet to do his work, much of which is of a clerical kind. The borrowers' counter is too restricted and confined, and the attendants are needlessly shut off from the rest of the public rooms, which do not include a boys' room on the ground-floor room. The public w.c.'s are not wanted, and are best left out, particularly in conjunction with a ladies' room. The contrivance of the plan is ingenious and well thought out; but there is a want of connection between the parts. The boys' room upstairs isolated from control would never do, and the author does not seem to have thought at all about the need of supplying boy readers with books. A big staircase is contrived to lead up practically to the one room, and the lifts shown from the book-store in the basement do not rise higher than the ground floor. The filing room and mending room are cut off too much from the public rooms, as well as stack rooms, to make a convenient arrangement. The librarian's house is situated on the first floor, as required, with a separate entrance up the return-street, and he has a garden too. The provisions are ample; but the scullery difficulty has not been overcome, neither do we like the top light for the servants' bedroom, or the long dark corridor connecting the landing with what is called the hall. Externally, the building is not very attractive, though it is well defined and not unsuitable in style. Anyway, it is the most

satisfactory of those before us. The author has done his best thoroughly, and undoubtedly deserves no little commendation.

"By Go" has made a more compact type of plan, and his scheme is much more to the purpose taken as a whole. The officials are in the centre of things. The great defect is the shortness of counter-space, and the small area in front of it; the borrowers' hall is all doors and windows and no room to move. Fancy several persons waiting at the counter and several others going in and out of the news-room. Nothing could be more inconvenient, not to mention the additional traffic in progress to the other rooms, all leading out of this circumscribed hall. The reference room, instead of occupying the most retired position available, is thrust to the front, overlooking the main thoroughfare, and the news-room, where the larger number of casual readers assemble to look at the papers, instead of being situate close to the entrance, is put at the back of the block. The librarian's house, which was specified to take the form of a flat on the first floor, is made an adjunct, and hardly carries out our intention. It is much more difficult to plan a house as "Centaur" has done than to make a separate tenement such as "By Go" has shown. The elevation is poor, and suggests a regulation Post-office sorting department rather than a suburban public library.

"Maggot's" plan is very compact, but the arrangement is disjointed, with parts out of proportion in area. The elevation shows ability, though the external façade does not emphasise as it should do the interior requirements. The librarian's rooms, lighted by big dormers, would not be very comfortable apartments. The central hall is too small, and the counter is not long enough. The boys' room is cut off from the library books department, and the reference-room is not in a quiet position as it should be.

"Gossip" does not do himself justice. He draws so roughly and carelessly. The lending library has a good counter, but the reference-room has no connection with the stack space, while the librarian is put meaninglessly at the end of a corridor in a sort of watch-box between the reference-room and the newspaper room. The ladies' room is on the first floor. The public rooms are warmed by open fireplaces—a most objectionable mode to adopt, even though they are supplemented by a heating chamber in the basement. Architecturally, the design is one of the best. "Pantile" adopts what may be called the fashionable style of sprawling curved pediments and curiously proportioned other features. This he does with some cleverness; but he has little knowledge of library arrangement, and less concern as to the comfort of the librarian, if we may judge by the height and shape of the windows in the big dining-room, which is, if anything, too large. "Bernard" puts too many walls in his library, and, by wedging the hall of the librarian's house between the reference-room and the lending library, renders two stack-rooms or bookcase spaces necessary, leaving the librarian's room as the only means of communication between the two. The newspaper-room and magazine department are treated regardless of central control. The elevations are bald in the extreme. "Derige" is better in this respect, and in some ways has a good plan, though it is open to some of the faults already mentioned. The windows to the house are out of all proportion and quite inadequate. The author, who draws well, ought to have done much better than this. "Orb" is most careful. His entrance is too narrow, and has little public w.c.'s and lavatories on either side of it. The big public rooms are all at the back, connected one with the other. The plan, in fact, has many merits, both upstairs as well as down, and the elevations, though commonplace, are suitable. We recognise the author's care and painstaking, so that we regret not to be able to place him higher. "Dachs" shows originality and an endeavour to be up to date. His plan is worked out seriously, with not a few items deserving of praise; but he has not made an attractive design or drawn it particularly well. "Hotspur" is very inky in his perspective, which shows a tasteful design in spite of the paltry shafts at the main entrance. The rooms are nicely connected for supervision, but the borrowers' space is far too restricted. The house for the librarian is placed on the first floor. Domed lights occur over the public rooms in some cases. "Stone" sends a brick design badly drawn. His plan has a spacious central area surrounded by

the public rooms. The arrangement is rather good and on the right lines. The author has not worked it out sufficiently in detail, and his elevations we do not admire. "Phantom" is more crude still, and not so satisfactory. "Gib" has a great idea of a balance. Without it his elevation would be nothing, and with it his plan is very badly contrived. Isolation dominates everywhere, and supervision would be most expensive and inconvenient. "Gib" is by no means devoid, however, of architectural notions. We hope he will do better another time. "Check-mate" sends a plan with a notion, but he has not properly worked it out. His elevation is excessively poor. His staircases are very bad. "Suburb" is neat to a fault, and gives a big lending library. This is disconnected from the reference room, and the news-room is much too small. The elevation is commonplace, and there is no view given. The other designs are ranked in following order: "Wessex," "Klondyke," "Tee-Square," "Eric," "Excelsior," "Don," and "Don't Know," who has left his in pencil. He never will know unless he works better, though we do see some improvement in his present attempt. This should inspire him to make more effort another time, in spite of other attractions.

#### PAVEMENT AND OTHER LIGHTS.

WE have received from Messrs. Wilson and Co., pavement-light engineers, and makers of Wilson's patent dioptrical and other pavement-lights, of 24, Harrison-street, Gray's Inn-road, W.C., a new catalogue of their valuable "Dioptrical" and other pavement-lights for transmission of daylight to basements and underground premises. Wilson's "New Dioptric" lens is the latest improvement in this direction, and it is the result of many years' experience and study of optical principles. The inventors claim for this lens the dioptrical effect of the concave lens in diffusing light over a larger area than the semi-prism. Several illustrations show the application of this lens to pavement and floor lights, also to corridors, landings, stair-treads, inside floor-lights. They are made to prevent slipping, the upper part of the frames being of lead. Wilson's improved illuminating stallboards are made in several patterns, plain and ornamental, and of different sizes, to suit all requirements. The section of the bars under the lights enables the moisture of condensation to be carried away harmlessly. Several designs and sections are shown for floor and roof-lights worth the attention of the architect and builder of city business premises.

#### CHIPS.

The rebuilding and widening of Howford Bridge over the river Cart, near Paisley, has just been completed at a total cost of £2,630.

An important scheme which is being pushed forward by the Liverpool Corporation is that known as the Hood-street improvements. The demolition of property is being proceeded with; and when the undertaking is completed, Hood-street, which is now somewhat narrow, will be converted into a wide thoroughfare, and thus greatly facilitate vehicular traffic.

On Wednesday week, services were held in the church of All Hallows, London-wall, E.C., to celebrate the completion of the main features of the work of renovation. The church has been cleaned, repaired, and restored; the electric light has been installed; and a gilded cross, designed by Sir A. W. Blomfield, A.R.A., has been placed upon the top of the tower. The work has been in progress for seven years, and has cost £1,700.

The work of preparing for the erection of the new technical school, to adjoin the museum in William-Brown-street, Liverpool, is going on apace. The site has now been cleared of all the old buildings, and men are busily engaged in making the excavations necessary for the foundations for the building, to be erected from the plans of Mr. E. W. Mountford, F.R.I.B.A., of London.

In order to make future provision for the constantly growing traffic, the Directors of the Great Northern Railway Company have deemed it advisable, instead of doubling the three tunnels on the main line between Barnet and Potter's Bar, and duplicating the expensive viaduct and two tunnels at Welwyn, to seek Parliamentary powers next session to construct a loop line twenty miles long from Enfield to Stevenage Station, which will give an alternative route between Wood Green (about five miles from London), and the main line, a short distance south of Stevenage Station, where it will connect with lines already widened.

#### OBITUARY.

Mr. MICHAEL DAINTRY HOLLINS, late of Whitmore Hall, died at Springfield Hall, near Newcastle-under-Lyme, on Tuesday. The deceased was the fourth son of the late Mr. Thomas Hollins, of Manchester, was born in 1815, and in 1844 he married Elizabeth, the daughter of the late Thomas Mackenzie, M.D., of Newcastle-under-Lyme, by whom he had a family of four sons and four daughters. His wife and sons predeceased him, but the daughters and several grandchildren survive. Mr. Hollins for some time practised as a surgeon; but in 1839 he came to Stoke to assist his uncle, the late Mr. Herbert Minton, the potter, taking charge of the manufacturing departments, while Mr. Minton retained the control of the commercial department. In 1849 the late Mr. Colin Minton Campbell became a partner in the firm, and in 1853 Mr. Herbert Minton died, and the business was subsequently carried on by Mr. Campbell and Mr. Hollins. In 1868 the partnership was dissolved, Mr. Campbell carrying on the manufacture of china and earthenware under the style of Minton's, while Mr. Hollins took over the encaustic tile branch. This business he afterwards carried on at the Cliffe Vale Works, under the style of Minton, Hollins, and Company, and obtained a wide reputation for the productions of his manufactory. The deceased gentleman was a D.L. and J.P. for Staffordshire, and for some years discharged the duties of chairman of the Newcastle Petty Sessional Division. Mr. Hollins was the first captain of the Stoke Company of what is now the 1st Volunteer Battalion North Staffordshire Regiment.

Mr. ROBERT HOWE, who for a quarter of a century has been clerk of the works in the Office of Works Department at Windsor Castle, died suddenly on Saturday morning at his residence, within the Palace precincts. Mr. Howe, who was 68 years of age, formerly held a similar position at Kew, and since his appointment to Windsor Castle in 1873 had charge of all the alterations and improvements at the Royal residence and the buildings in the Home Park. He also supervised the reconstruction of the Lord Chamberlain's stores next the Winchester Tower, the arrangements for an improved water service for the Castle, and other works.

The death occurred on Tuesday, at Broomlands, Hatherton, Cheshire, of Mr. C. J. MARE, ship and bridge builder. He owned shipbuilding yards at Blackwall, Millwall, and Northfleet, and constructed the Britannia tubular bridge over the Menai Straits, Saltash Bridge, and Westminster Bridge. He married the eldest daughter of the late Mr. Peter Rolt, once member for Greenwich. Mr. Mare was elected as Conservative member of Parliament for Plymouth in 1852, but was unseated on petition in the following year.

The death occurred on Saturday morning of Mr. JOSEPH LEES, of Lytham View, Ashton-on-Ribble, Preston, aged 52. The deceased was an ex-Mayor of Bacup, which town he left in 1889. He was articled to Mr. Dawson, late of Newchurch, as architect and surveyor. Before the term for which he was articled had expired, Mr. Dawson gave up business, and Mr. Lees was transferred to Mr. Bell, of Accrington, where he remained until his articles expired, and then became an assistant surveyor to the Over Darwen Local Board, and afterwards was appointed surveyor to the Middleton Commissioners. For 4½ years he held this position, and then succeeded, in conjunction with his eldest brother, Mr. B. Lees, to the proprietary of collieries long held by their father, the late Mr. Robert Lees. Mr. Joseph Lees was a member of the local board and afterwards of the Corporation of Bacup, becoming mayor for 1887-8. Shortly after retiring from the chair he removed to Ashton-on-Ribble, as managing director of the Oxheys Spinning Company, Preston.

The town council of Birkenhead have decided to erect public baths at the north end of the town, at a cost of £13,000.

The Earl of Jersey presided over a Board of Trade inquiry held at Grimsby, on Friday, into the proposed light railway from Saltfleetby to Cleethorpes and Grimsby. On behalf of the promoter, it was stated that the scheme was estimated to cost £53,212, of which £2,000 had been left for incidental expenses. No objection was raised to the scheme as a whole, and the Commissioners decided to recommend the order to be made.

#### ARCHITECTURAL & ARCHÆOLOGICAL SOCIETIES.

BATH MASTER BUILDERS' ASSOCIATION.—The annual dinner of this association was held on Tuesday night at Fort's Restaurant, Bath, under the presidency of Mr. Geo. J. Long. The toast of the "National Association of Master Builders of Great Britain and the Federation of the West of England and South Wales" was given by Mr. G. Parrin, of Bristol. Mr. A. Krauss, of Bristol, responded. Mr. E. W. Wood gave "Architects and Surveyors." Messrs. T. B. Silcock and H. W. Matthews responded. Mr. F. N. Cowlin, of Bristol, proposed "The Bath Master Builders' Association," and the president replied. Mr. W. Dyer, of the Weston-super-Mare Association, responded to the toast of "Kindred Associations."

EDINBURGH ARCHITECTURAL SOCIETY.—The first meeting of the session in connection with this society was held on the evening of Feb. 2nd in Dowell's Rooms, George-street, when there was a large turn-out of members. Mr. W. N. Cumming, the president, occupied the chair. The awards in the various prize competitions held during the past session were announced. These were as follows:—Hon. president's prizes for "A design for a branch free library, museum, and picture gallery"—first, Mr. W. A. Mellon; second, Mr. W. Fairbairn. President's prize for "Six sheets of measured work," Mr. J. H. Rutherford. Vice-president's prize for "Design for reredos and altar frontal for a country church," Mr. Percy E. Nobbs. Mr. Cumming announced that Mr. John Kinross, A.R.S.A., had consented to accept the honorary presidency, and then proceeded to sketch briefly the work proposed to be undertaken by the society during the session upon which it had entered.

LEEDS AND YORKSHIRE ARCHITECTURAL SOCIETY.—Mr. Wm. H. Thorp, F.R.I.B.A., lectured before this society in the Leeds Institute on Monday evening on "Early Renaissance Sculpture in Tuscany." Mr. Thorp gave a sketch of the chief characteristics of the three great schools of sculpture—the Greek of the time of Pericles, the early Renaissance of the 15th century, and the culminating period of the Renaissance.

NOTTINGHAM MASTER BUILDERS' ASSOCIATION.—The annual dinner of this association took place on the 3rd inst. at the Albert Hotel, Derby-road. Mr. J. Wright, president of the association, occupied the chair, and Mr. W. Edgar, vice-president, the vice-chair. Mr. J. Woodsend submitted "The Mayor and Corporation of Nottingham," and Councillor A. Pyatt replied. The chairman next proposed "Success to the Master Builders' Association." He congratulated the members upon the activity of the past year. Another source of congratulation was the fact that they had had very little trouble with the workmen during the past year. Last year they announced that they had reconstructed the Master Builders' Association, by which a committee representing every trade undertook the matters relating to the different sections. A very voluminous report prepared by Mr. Hodson, their energetic secretary, recounted the work done by those various committees, upon which they had to congratulate themselves. As an association, they were on satisfactory terms with the Architects' Association, and they had recently had a meeting with members of the Architects' Association, at which they put before them various points which they wanted them to consider in framing and drawing up future contracts, and the association received them in a very cordial and business-like manner. Mr. Henry Vickers and Mr. Frank Hodson responded to the toast. The vice-president proposed "The Visitors," to which Mr. Starkey (Leicester) and Mr. Belcher replied; and Mr. F. Fish gave "The Chairman." The speeches were interspersed with songs.

SHEFFIELD SOCIETY OF ARCHITECTS AND SURVEYORS.—The monthly meeting of this society was held on Tuesday evening. The chair was occupied by Mr. Joseph Smith (vice-president). Mr. Hugh Stannus, F.R.I.B.A., of the Royal College of Art, delivered a most interesting and useful lecture on "Proportion."

The Bishop of Rochester dedicated the new church of St. Hugh, Southwark, on Saturday afternoon. The church, which is situated in Crosby-row, Tabard-street, one of the narrow and old-fashioned streets at the rear of the site once occupied by the Marshalsea Prison, is in connection with the Charterhouse Mission.

CONTENTS.

Solidity and Straw	187
Party-Walls and Footings	188
Royal Institute of British Architects	188
Architectural Association	192
Surveyors as Arbitrators	193
The Surveyors' Institution Annual Dinner	194
Electric Lighting Notes for Architects.—XVI.	194
Stable Fittings	196
A Coat of Paint	197
BUILDING NEWS DESIGNING CLUB	198
Pavement and Other Lights	198
Obituary	198
Architectural and Archaeological Societies	198
THE BUILDING NEWS DIRECTORY	199
Our Illustrations	199
Royal Academy Drawings, 1898	199
Building Intelligence	218
Engineering Notes	218
Competitions	218
Correspondence	219
Intercommunication	220
Legal Intelligence	220
Our Office Table	221
Meetings for the Ensuing Week	222
Trade News	222
Latest Prices	222
List of Competitions Open	223
List of Tenders Open	223
Tenders	225

ILLUSTRATIONS.

"THE QUEST OF SIR PARSIFAL."—NATIONAL SILVER MEDAL DESIGN FOR A SMALL ART DEPARTMENT.—READING ROOM, HOTEL MARQUARDT, STUTTGART.—TECHNICAL SCHOOLS AND LECTURE HALL, WEST HARTLEPOOL.—DESIGNS FOR A PUBLIC LIBRARY.—CHAPEL AND SCHOOLS, WAYERLEY PARK, NUNHEAD.—OLD AND NEW DECORATIVE METAL WORK.

Our Illustrations.

"THE QUEST OF SIR PARSIFAL": NATIONAL SILVER MEDAL DESIGN.

AFTER five years' wandering in search of the Castle of Carbonek, where he must go to fulfil the quest of the Sangreal, Sir Parsifal comes at length to a tree in which he sees a vision of two children. They give him news of the road he must travel, and vanish. The cartoon illustrating this incident, which we publish to-day, was awarded a National Silver Medal last year, and has since been bought by Sir William B. Richmond, R.A., who gave his permission for its publication here. Miss Violet M. Holden, of Knowle, is the author of the design.

NATIONAL SILVER MEDAL DESIGN FOR A SMALL ART DEPARTMENT.

THIS design, for a small art department, is in the Early Roman style. On the ground floor there is a large central hall, lighted from the central dome above, which is also intended to be used as a sculpture gallery. To the right of the hall on entering is a library and librarian's room; on the left a large gallery for paintings. A hoist from the basement is provided for taking pictures to this gallery. There is also a lecture theatre on this floor to seat about 40 or 50 students, also ample cloak room and lavatory accommodation. The basement is used for picture stores and heating-chamber, &c. D. MCKAY STODDART.

HOTEL MARQUARDT, INTERIOR OF READING ROOM, STUTTGART.

MESSERS. EISENLOHR AND WEIGLE are the architects of this somewhat sumptuous building, which is furnished throughout in accordance with the style displayed by this apartment, wherein cabinetwork of a refined type is made to play an important part. The heating radiator is located in a sort of sideboard, after the fashion of a buffet, the sides of the lower part or body being filled with a metal grille. The newspaper-holders on the table give, of course, a singular effect in the picture, but are handy enough for use when the habit has been acquired. The photograph given by us to-day was sent us by Herr Ernst Wasmuth, the well-known architectural publisher, of Berlin, and it forms one of the plates appearing in his excellent folio publication, entitled, "Architektur der Gegenwart."

TECHNICAL SCHOOLS AND PUBLIC HALL, WEST HARTLEPOOL.

THESE buildings are an extensive range erected by the Town Council of West Hartlepool for mechanical science and art instruction, and are an attempt to give a large amount of accom-

modation at a minimum of expenditure, the contract having been let for £11,230 to Mr. Thos. Dickinson, of Middlesbrough, by whom the buildings have been erected, the cost per cube of contents not reaching the sum of 4d. per foot as measured in the ordinary way. The buildings have been extended beyond the accommodation provided by the competition plans, and as they occupy in length the whole site from front to back, the plan had to be accommodated to the awkward angle formed by the building-line of the Hart-road front with the square of the side streets, and seating having to be provided for 1,400 people in the large hall to this front, it necessitated every inch of space being utilised to the best advantage. The several fronts are faced with the best Accrington red pressed bricks with dressings of Dunhouse stone. Inside the walls are plastered and distempered suitable tints. All the halls, vestibules, and corridors, with lavatories, &c., on each floor, are of fireproof construction, and paved with marble mosaic to former, and granolithic cement paving, with border in colour, to latter items. The staircases are of hard York stone, with spandrel soffits, and the floors of classroom, lavatory, &c., of wood-block construction, and all the fittings internally are specially designed to be in character with the building, while keeping in view the required limitation of cost. The whole of the ranges are heated by hot-water pipes on the low-pressure system, with radiators and air-valves of the latest pattern. The drawing from which this view is taken is a hurried sketch in colour by the architect to explain the general idea of the block of buildings to the committee, made by their desire at a day or two's notice from immature plans, before the working drawing were elaborated; but it shows the scheme generally as carried out, and from lack of time is all that is available. Mr. H. A. Cheers is the architect.

"BUILDING NEWS" DESIGNING CLUB: A SMALL PUBLIC LIBRARY.

(For description and awards, see page 197.)

NEW CHAPEL AND SCHOOL, NUNHEAD.

THIS block of buildings has recently been erected in the Ivydale-road, Nunhead (a district known as Waverley Park), for the Methodist New Connexion. The site was given by the adjoining owner, and measures 100ft. frontage with a depth of 90ft., none too large for the accommodation required—viz., a chapel to seat not less than 400, and a hall or schoolroom to accommodate the same number, besides accessories. By uniting the two in one block, as shown, space has been economised, whilst ample light is secured to the chapel by clerestory windows above the roof of the hall, which is kept at a lower level. There are no galleries; but provision is made for such in future when required. The walls are of brick, with dressings of Monk's Park stone. The upper part of turret is of oak. The design is the result of a limited competition, Mr. R. Clamp, of Woking, being the architect. Mr. E. Jones, of Nunhead, is the builder, and the cost was under £3,000.

DECORATIVE METALWORK, OLD AND NEW.

THE sheet of sketches which we publish amongst this week's illustrations contains an elaborate and beautiful design in scroll ironwork, which forms the top of a reading-desk in a church near Mantua. The long arm to the left is for the purpose of suspending a lantern to light the lectern. The door-handle from Ulm is decorated with a couple of freely-treated dolphins, joined at the snouts and tails. C and D are suggestive examples of door furniture from a house in Wertheim-on-the-Maine, whilst A and B are modern designs by Professor Ohmann for the palace of the Hradschin at Prague.

Mr. J. Palfreman, late of the Royal Courts of Justice, commenced his duties on Tuesday as works resident engineer at the Houses of Parliament, having been appointed in succession to Mr. W. J. Prim, who has retired upon a pension.

At Newhailes House, N.B., on Friday afternoon, Sir Charles Dalrymple, Bart., M.P., was presented with his bust in marble from the Grand Lodge of Freemasons. Sir Charles has been Grand Master for three years, and the gift was in recognition of his craft. The bust, which stands on a marble pillar, has been executed by Mr. W. Grant Stevenson, R.S.A., of Edinburgh, and after exhibition at the Royal Scottish Academy will be placed in the Freemasons' Hall.

ROYAL ACADEMY DRAWINGS, 1898.

THE last day this year for sending in architectural and decorative drawings to the Royal Academy is Monday, March 28th next.

We have to acknowledge many promises to lend us drawings for reproduction before they are sent in, to be illustrated in our pages after the exhibition opens as in former years. We shall be glad to receive other offers of drawings intended for the Royal Academy, and they should reach us as early as possible, not later than March 24th. Contributors who may wish us to receive and deliver their drawings for them to Burlington House (and we are willing to undertake this free of charge for contributors) must fix a label on the back of the picture and attach another by means of a string. These labels must give the title of the subject, and also the name and address of the sender. The labels can be obtained from the secretary of the Royal Academy of Arts, Burlington House, Piccadilly.

CHIPS.

The Bishop of Ely has presented an altar frontal to his cathedral as a thank-offering for the escape of himself and a party of friends, who were in the gallery of the episcopal palace when the floor gave way. The frontal has been worked by the Wantage Sisters, after a design taken from a fifteenth-century vestment in Rheims Cathedral, and the gold material was brought from Moscow.

A meeting of the Hartlepool timber merchants was held the other day, presided over by the mayor, to consider the regulations submitted by the railway company for working the timber trade, whose leading members have recently expressed complaints respecting the very inefficient accommodation provided for the discharging of cargoes. The general opinion expressed respecting the proposals of the company was that the trade would be seriously harassed thereby, and a committee was appointed to ascertain the feeling of the trade upon the subject, and to report thereupon.

Mr. George Bradbury, the surveyor to the Diocese of Liverpool, has been engaged for several months in collecting information with reference to St. George's Church, Liverpool. The present building is not in any part, except the internal columns and fittings, the original erection, as the outside walls were at one time pulled down separately and rebuilt as they are to-day. Furthermore, the present spire was only erected by the municipal authorities in 1818, the original spire having been demolished some nine years previously.

At the last meeting of the town council of Salford the salary of Mr. Wilson, principal of the technical institute, was raised from £350 to £450 per annum; and that of Mr. Turner, the borough electrical engineer, was increased from £260 to £300 per annum.

Works of heating and of hot and cold water-supply have just been completed at the workhouse at Northallerton. Mr. F. Graham Fairbank, of York, was the engineer, and Mr. Bedford, of Northallerton, the contractor. The cost was £540.

The demolition of the Elephant and Castle and adjoining buildings forming an island block of properties facing Newington-causeway, Walworth-road, and Short-street, is in progress. The London County Council have voted £9,550 towards the contribution by the Newington vestry for the widening of the thoroughfare at this important centre. We illustrated the new hotel and premises, which are to be built from designs by Mr. John Farrer, of Finsbury-pavement, in our issue of the 21st ult. The contract has been taken by Mr. H. L. Holloway, of Deptford, at £35,000.

The Wolverhampton Board of Guardians have finally decided to purchase, as the site for the proposed new workhouse, the New Cross estate of 50½ acres, the price paid being £11,128.

In St. Mark's Church, Noel Park, London, a pulpit has been dedicated in memory of the late Bishop of Wakefield. A carved Litany desk, the gift of the Boys' Guild, was also used for the first time on Sunday morning. The design of the pulpit, which is of Caen stone, has been given by the architect of the church, Mr. Rowland Plumble. In the central niche is a figure of St. Mark bearing the patriarchal cross of Alexandria, and it is proposed, when funds allow, to fill the other niches with figures of Bishop Walsham How and St. Chad, Bishop of Lichfield.

A new hall is in course of erection at Murieston-road, Dalry, N.B., for the Salvation Army. For adult work the building will accommodate 350, and for juvenile services 200. Officers' quarters are also provided. Site and premises will cost nearly £1,000. The foundation-stone-laying ceremony took place on Saturday.

# DECORATIVE METALWORK OLD & NEW

TOP OF A READING DESK  
IN S. BENEDETTO - NB MANTUA

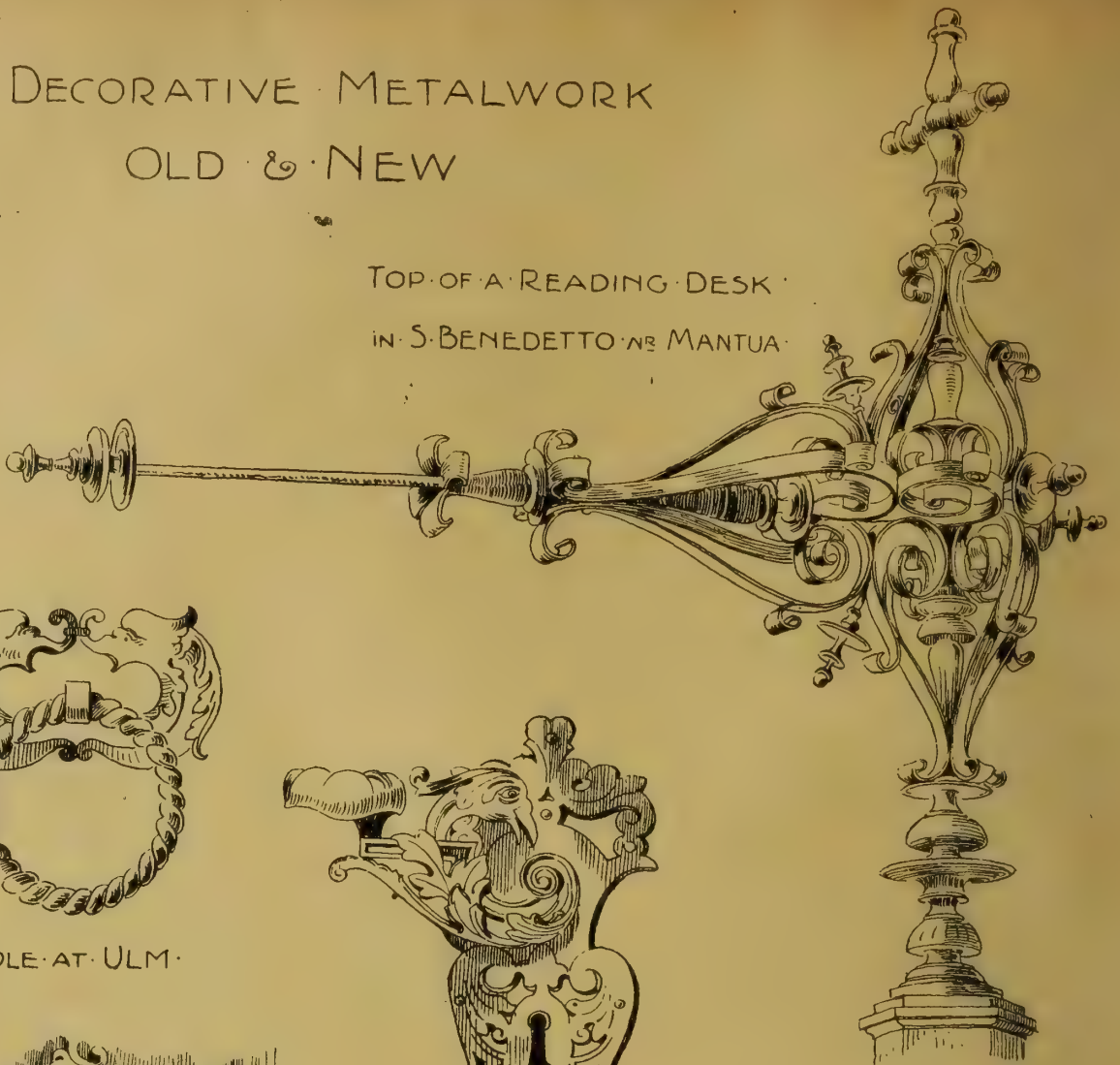

HANDLE AT ULM



C & D - DOOR FURNITURE  
IN WERTHEIM - ON THE MAINE

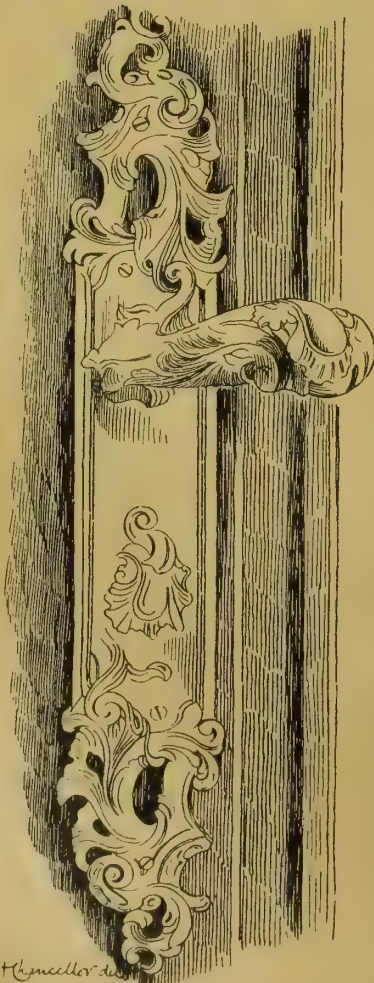

A

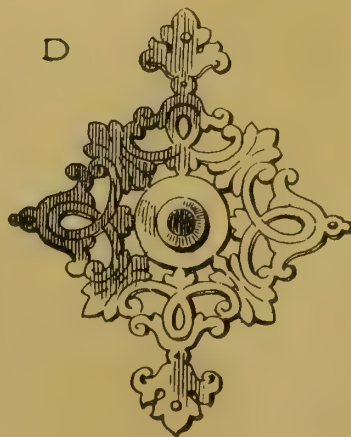

D

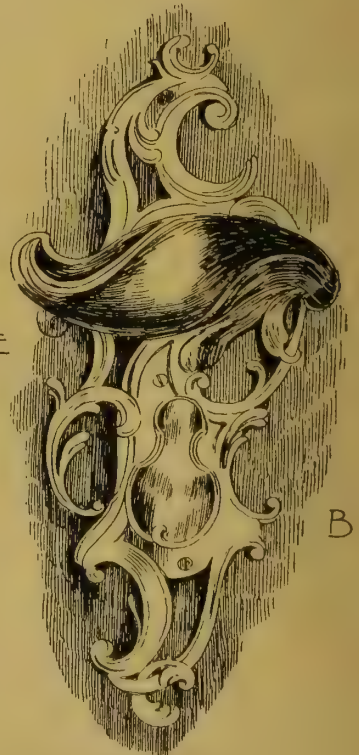

B

A & B - DOOR FURNITURE  
PALACE OF THE HRADSCHIN  
PRAGUE  
PROF F OHMANN ARCHT





B.N.D.C. A PUBLIC LIBRARY.  
BY "CENTAUR".

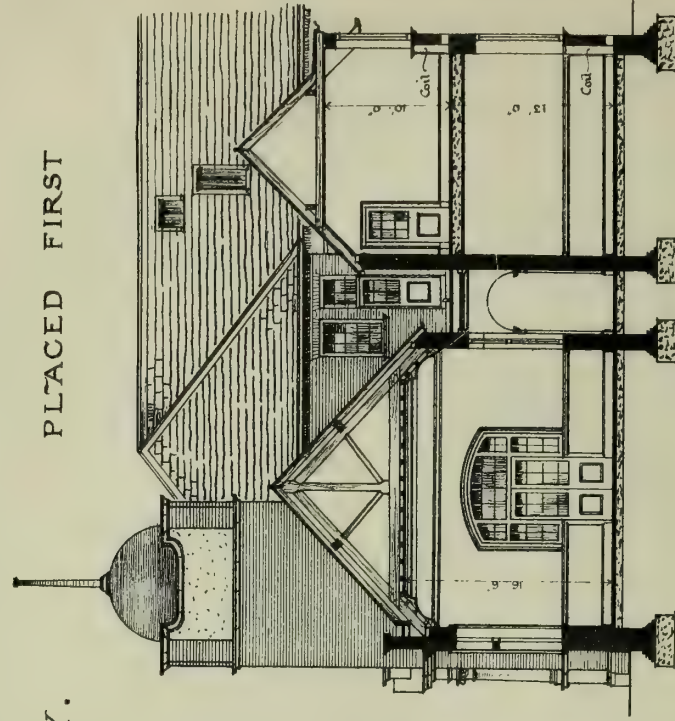
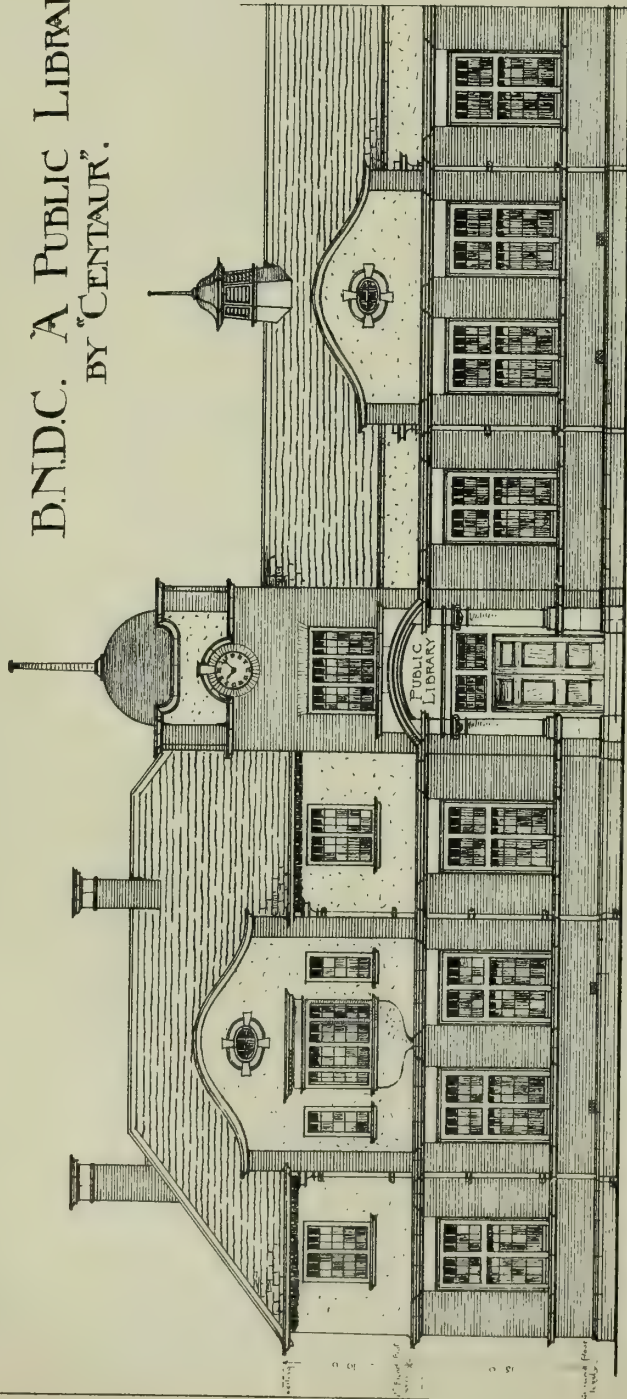

Section at A.B.

Front Elevation.

Scale of 1" = 10 Feet.

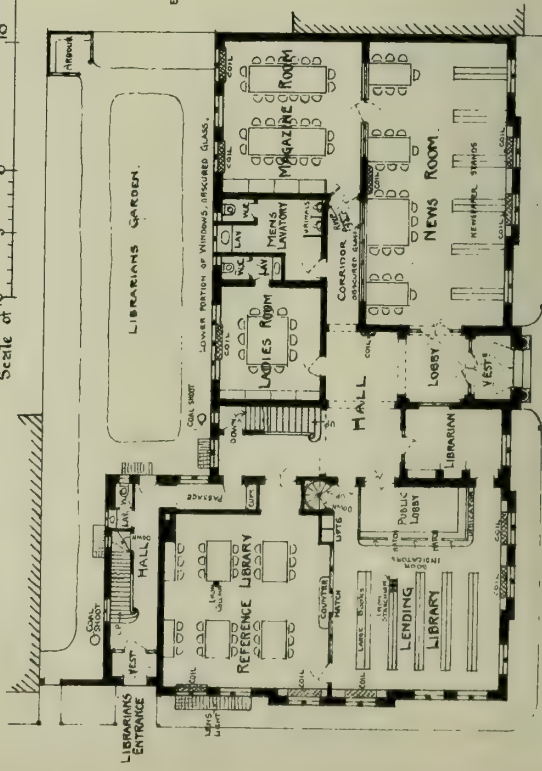

Plan of Ground Floor.

Scale of 1" = 10 Feet.

Note. Glass in upper part of all doors on ground floor.

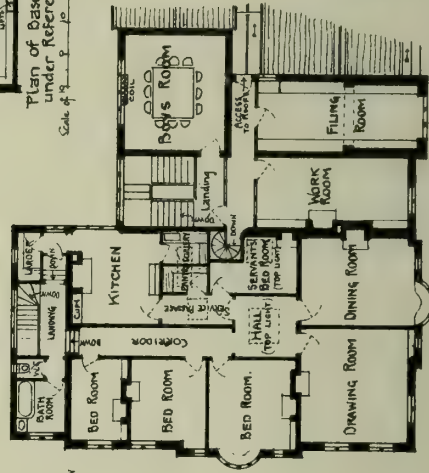

Plan of 1st Floor.

Scale of 1" = 10 Feet.

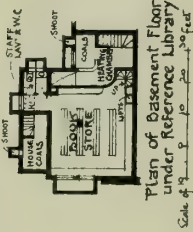

Plan of Basement Floor under Reference Library.

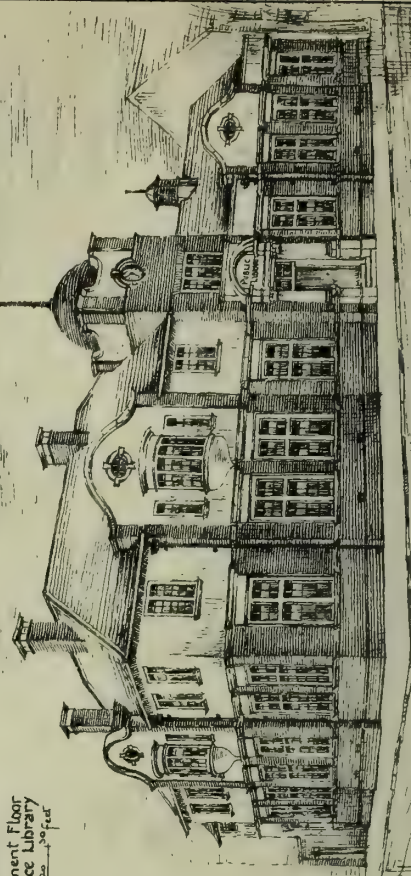

N.E. View



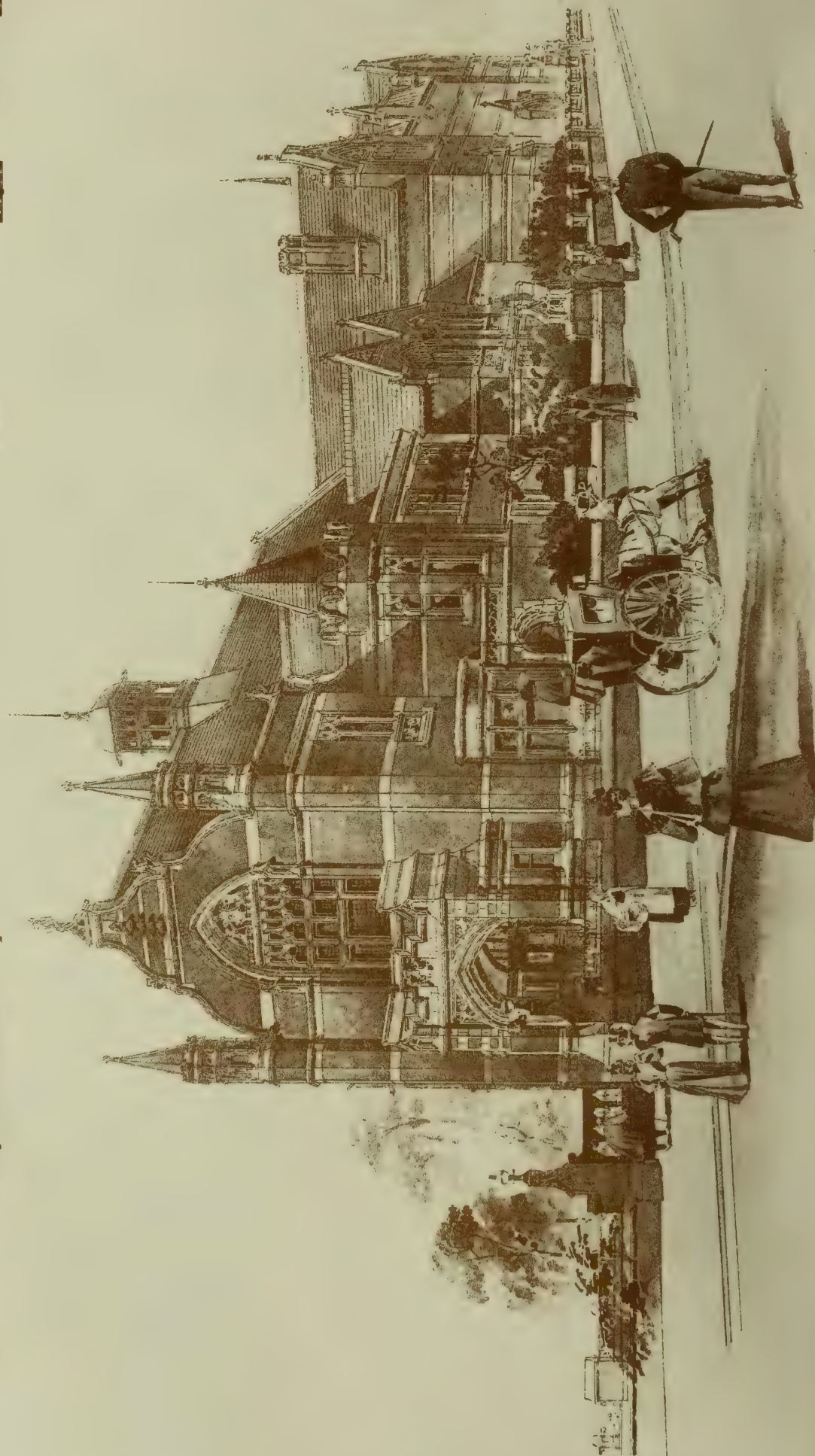

"PHOTO-TINT" BY JAMES AKERMAN & SONS, 2, BURY ST. MARKET, LONDON, W.

THE BUILDING PEWS, FEB. 11, 1898.

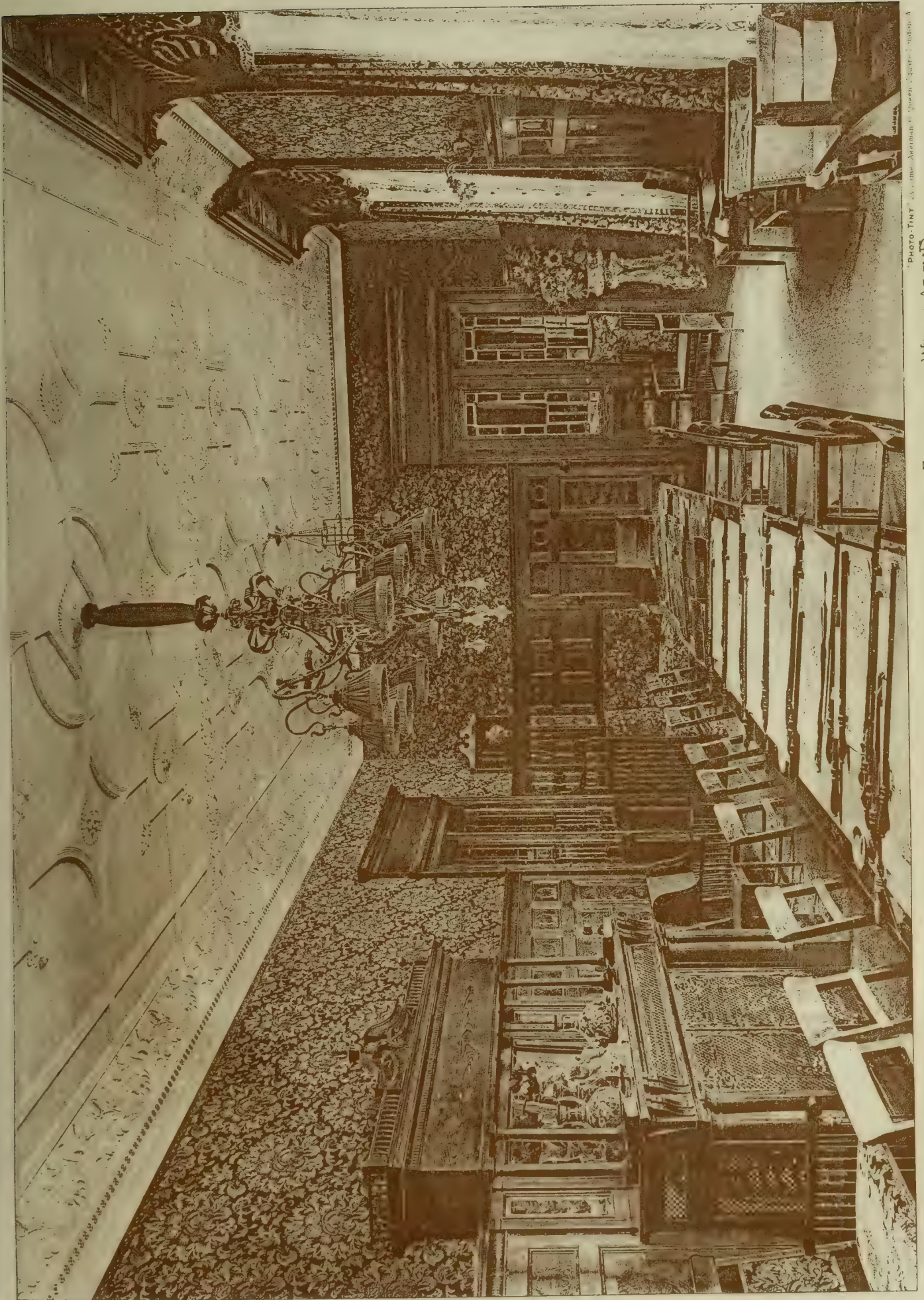

PHOTO. TINT. BY THE AGENCY OF THE PHOTO. TINT. STUDIO. A.

READING ROOM HOTEL MARQUARDT STUTTGART · EISENLOHR & WEGLE ARCHT<sup>DS</sup>













THE QUEST OF SIR PARSIFAL

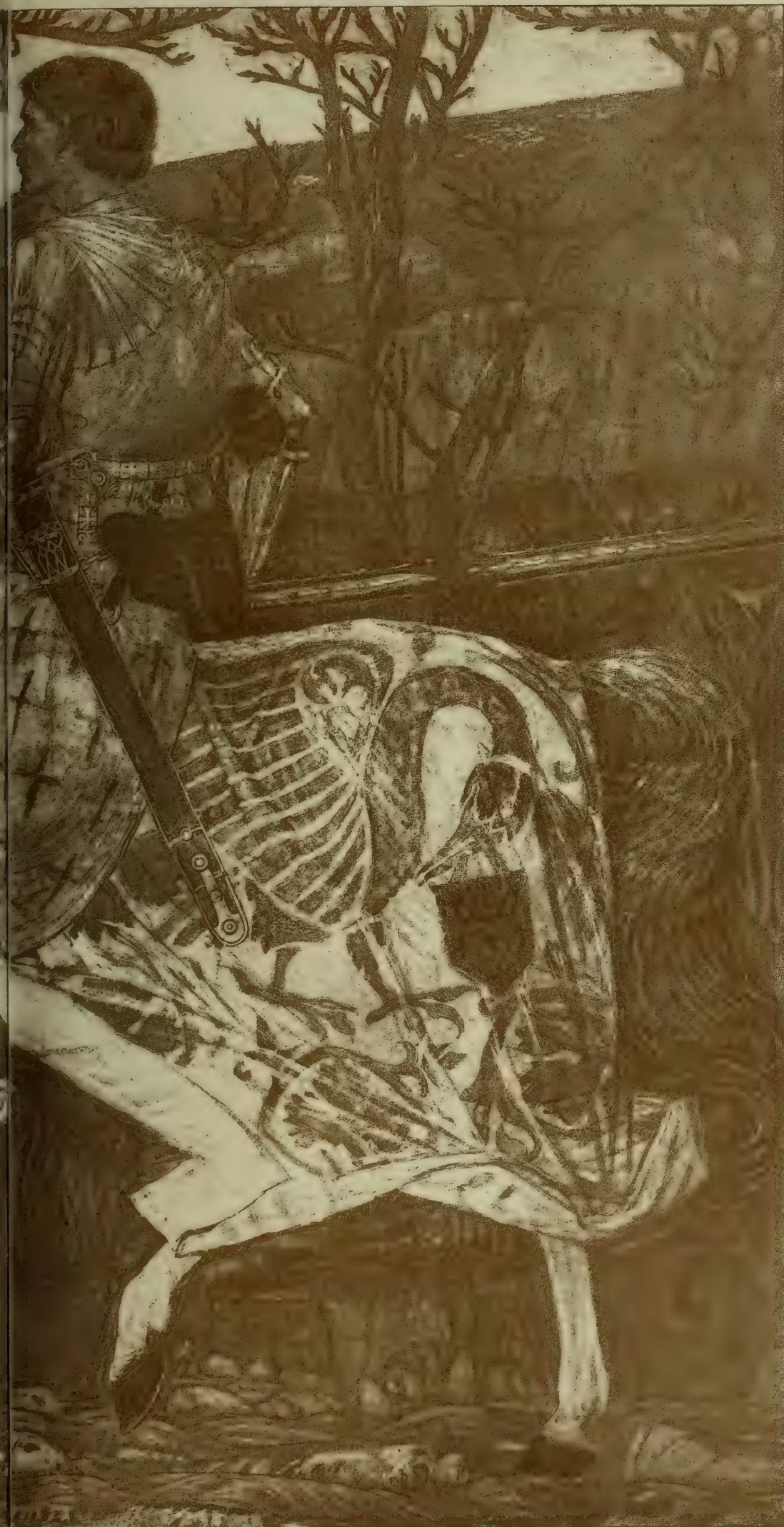

"PHOTO-TINT" by James Akerman. 6, Queen Square, London, W.C.





BACK ELEVATION

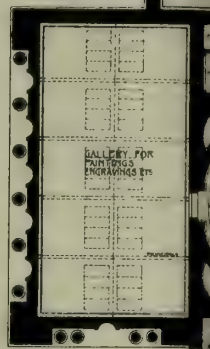
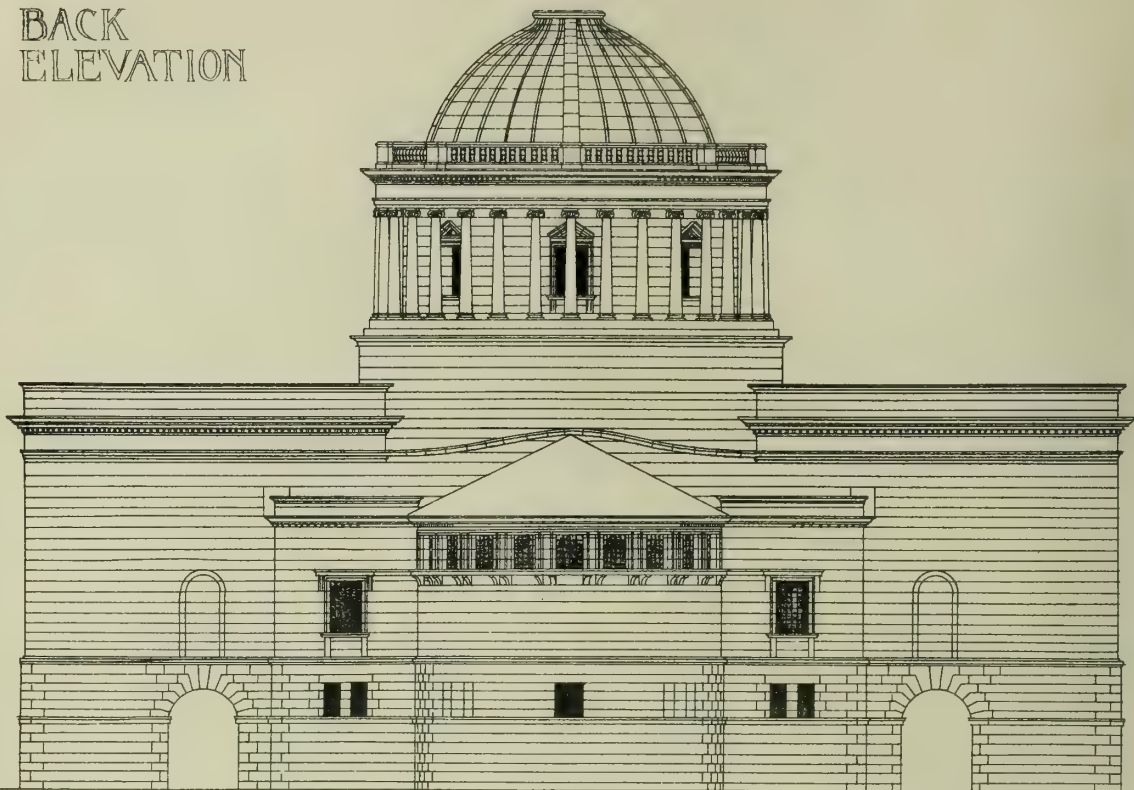

PLAN OF GALLERY AND LIBRARY BY FLOOR ROOM

PLAN OF GROUND FLOOR

DESIGN FOR A SMALL ART DEPARTMENT

FRONT ELEVATION

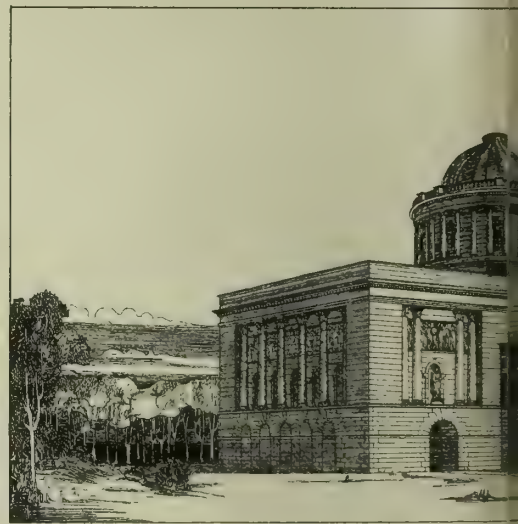
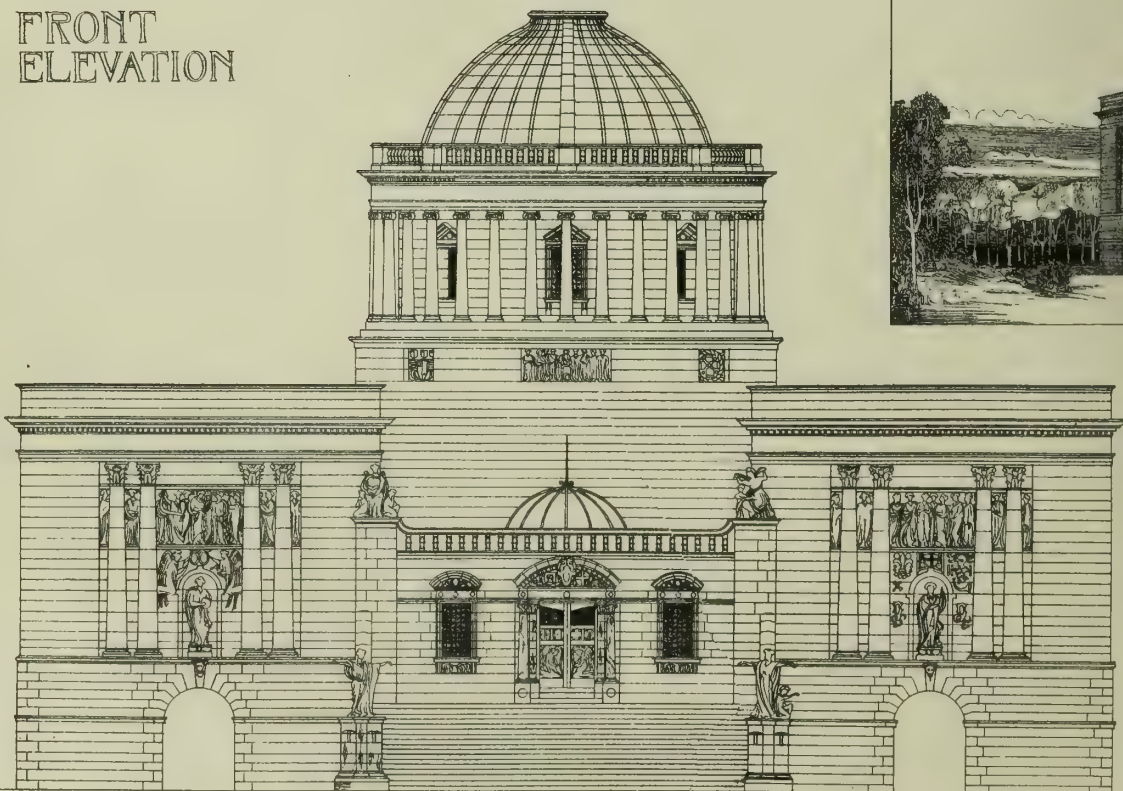

NATIONAL SCHOOL

D. MCK

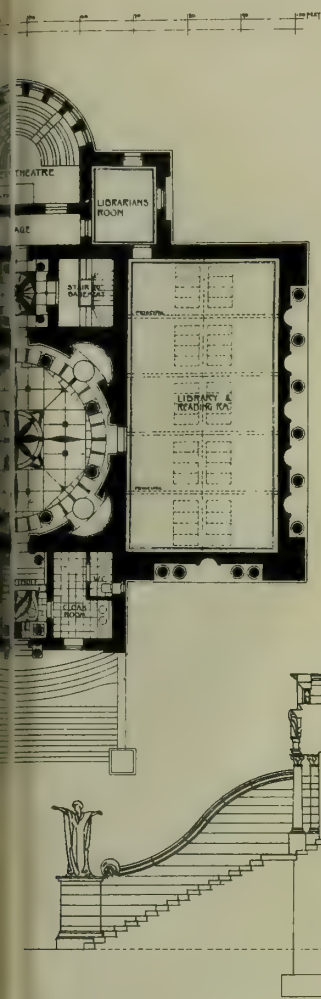

SECTION

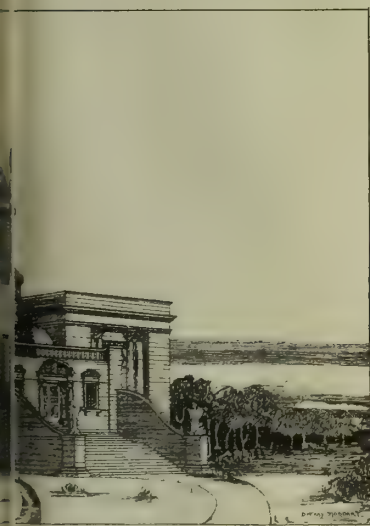
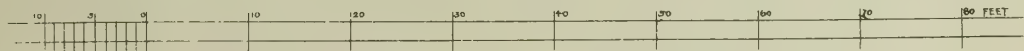
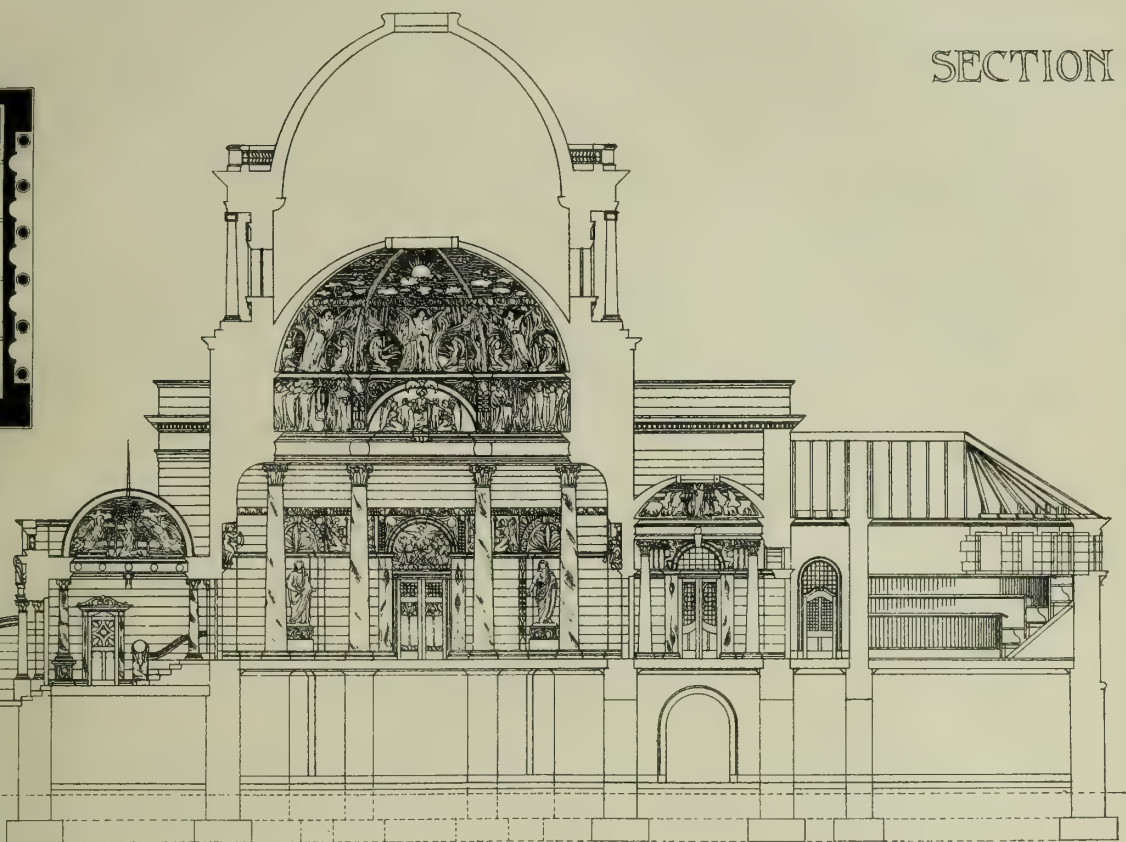

SIDE ELEVATION

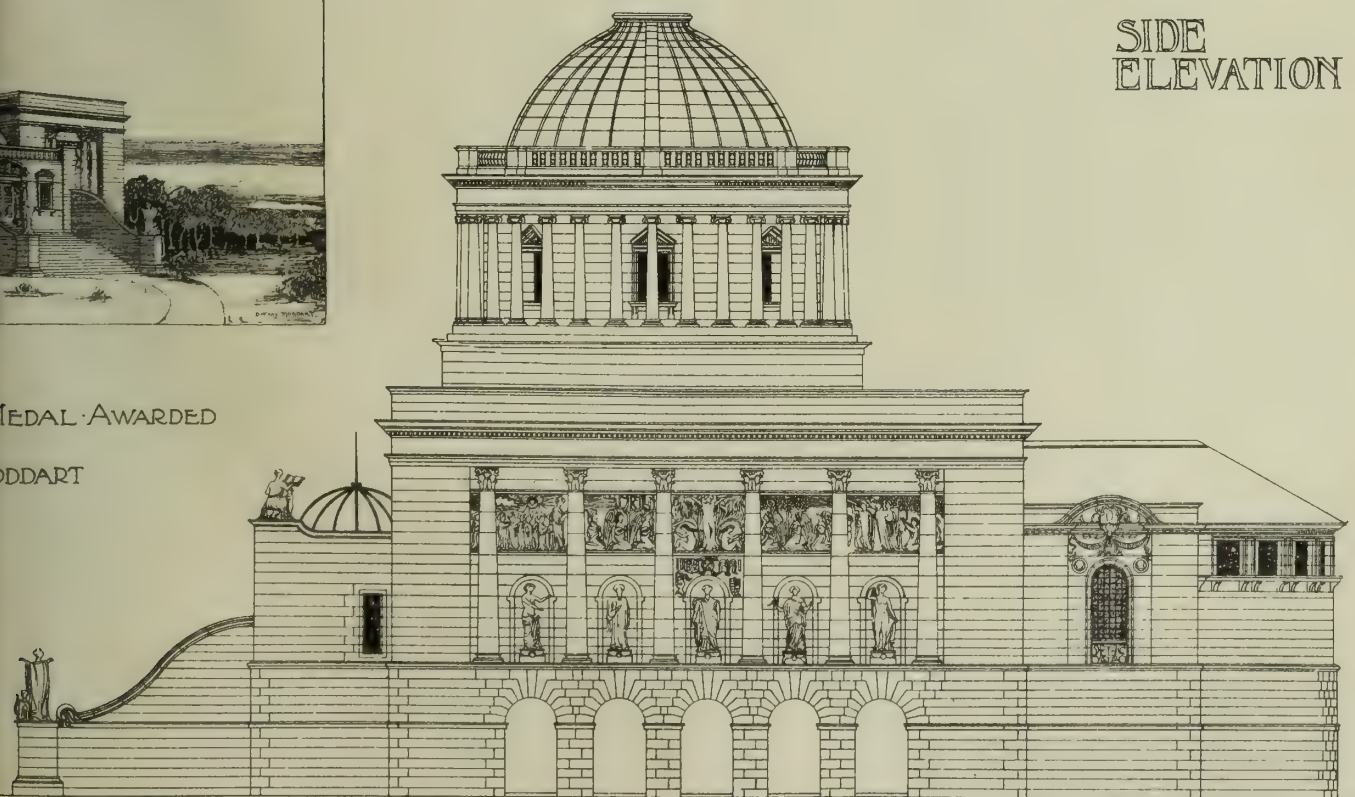

...MEDAL AWARDED

...TODDART





CHAPEL & SCHOOLS  
WAVERLEY PARK · NUNHEAD · SE.  
ROBERT CLAMP ARIBA ARCHT

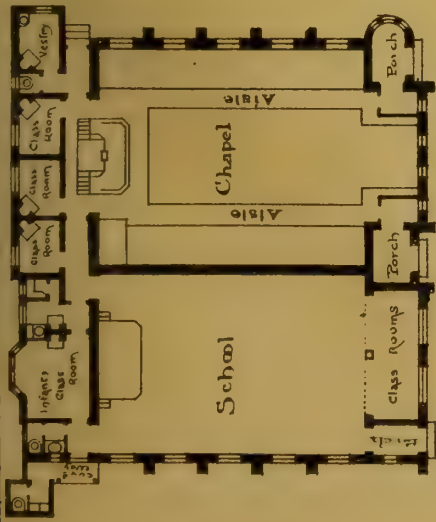

Plan

Scale 0 5 10 20 Feet

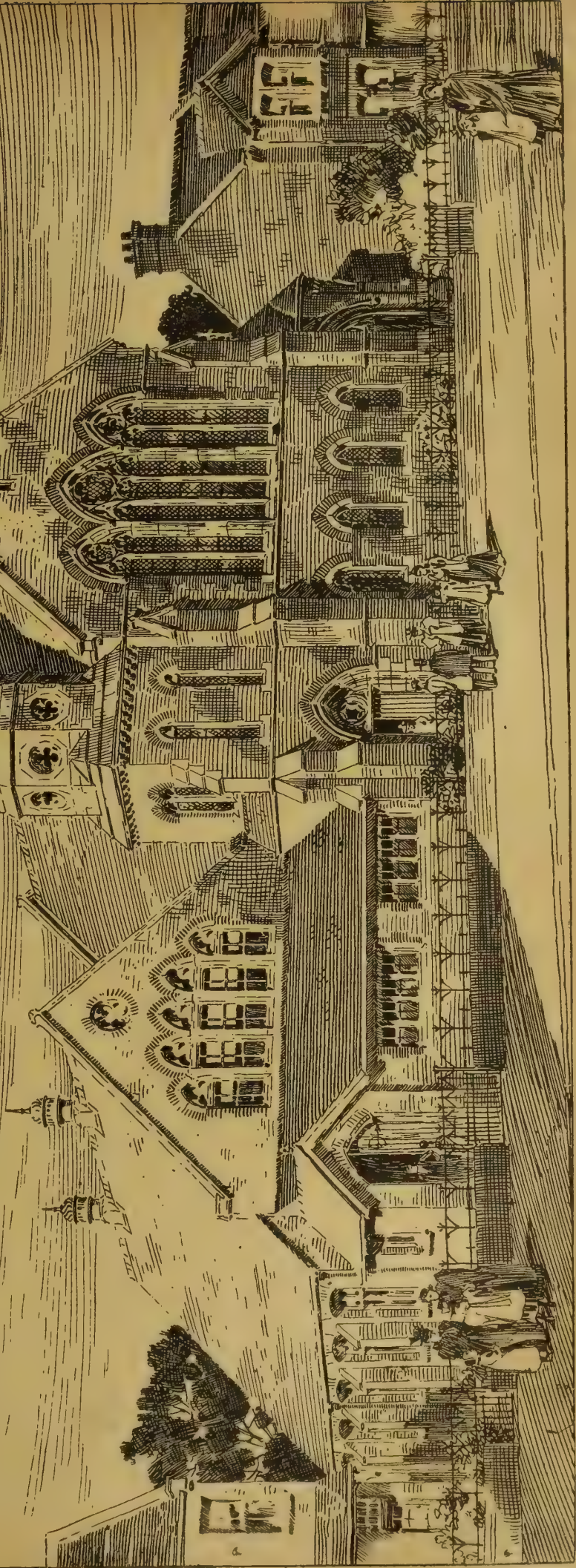

## Building Intelligence.

**HOYLAKE, CHESHIRE.**—The new town-hall was opened by Colonel Cotton-Todrell, M.P., on the 2nd inst. The council offices are all situated on the ground floor, and are approached from Market-street by a central porch. The council chamber, which measures 38ft. by 22ft., stands at the right of the main entrance, and possesses a lofty coved and recessed ceiling, filled with enriched panelling. By pilasters the walls are formed into panels, the lower portion having an oak dado. The public-hall, which is on the first floor, provides accommodation for 500 persons. The stage has been provided with a movable proscenium, and there are also ladies' and gentlemen's dressing-rooms, lavatories, refreshment-rooms, promenades, and a caretaker's residence. The remaining departments included in the scheme are the fire-station, and the technical classrooms. Heat is supplied to the buildings by means of hot-water pipes, open fires, and a ventilating radiator. The general contract has been carried out by Mr. W. H. Forde, from the designs, and under the superintendence, of the architect, Mr. T. W. Cubbon, of Birkenhead, who was placed first in open competition by a professional assessor. The total cost, including furnishing, has been about £6,500.

**LEEDS.**—The business of the National Provincial Bank in Leeds was transferred on Friday from the old premises at the junction of Albion-street and Bond-street to the new structure in Park-row, opposite the site of the old post-office. Messrs. Perkin and Bulmer, of Leeds, are the architects for the new bank, which is two stories in height, and in the Renaissance style. The lower half of the elevation is faced with grey granite beneath and black Labrador granite above. The upper half is a mixture of scarlet bricks from Berkshire and Yorkshire stone. Light green Westmoreland slates cover the roof. The back of the building has a frontage to Basinghall-street, and here salt-glazed Leeds bricks and timber-framed windows, painted white, are used. The bank-chamber is 70ft. by 42ft.; the walls being panelled in teak to a height of 12ft.; above this there is a lining of marble, and the frieze and ceiling are wrought in fibrous plaster. The counter is of teak, and has a highly-wrought aluminium grill. The floor in front of the counter is of marble mosaic, and behind of oak blocks. The electric-light fittings are of aluminium. A strong-room of steel is provided, and close to it is a lift. On the second floor accommodation has been provided for the clerks, including a luncheon-room; and rooms for the porter are situated above the second floor. The general contract has been carried out by Messrs. Armitage and Hodgson, of Leeds.

**MELTHAM.**—A town-hall, which has been presented to the growing district of Meltham, near Huddersfield, by Mr. Edward Brook, was formally opened on Saturday. In style the building is semi-Gothic, and the shell is constructed of Yorkshire rock-faced wall stones, relieved with ashlar dressings. The entrance opens into a vestibule and corridor, the clerk's, surveyor's, and other offices being on the first floor. It was thought unnecessary to provide accommodation for an assembly-room, and accordingly the council chamber and committee-room have been allocated to the first floor. Both apartments are furnished in solid mahogany, and upholstered in tapestry and plush. A four-dial turret-clock surmounts the building, and, exclusive of the site, which was also given by Mr. Brook, the cost of the building and furnishings is £2,882.

The death of Mr. Robert Chapman Garland, of Potternewton-lane, Leeds, took place on Saturday afternoon. Mr. Garland, who was in his 73rd year, died from heart-disease, after ten days' illness. For many years he carried on business in Leeds as a builder.

At a meeting of the subscribers of the Royal Alexandra Children's Hospital held at Rhyl last week, it was reported that the committee had selected a tender of £15,689 for the erection of the new hospital block and one of £12,041 for the administrative block, making a total of £27,730. The total assets at present amounted to £17,757, and the committee thought it desirable to proceed only with the erection of the hospital block, and to defer the other work until the funds had been augmented. The report was adopted.

## Engineering Notes.

**LEITH AND NEWHAVEN EXTENSION RAILWAY.**—Messrs. William Beattie and Sons, Edinburgh, who have secured the contract for the first section of the extension of the Caledonian Railway Company's Newhaven and Leith extension, have already begun operations. Although this section of the work is scarcely a mile in length, the contract price is about £50,000. The portion of the extension now commenced leaves the present Leith line at two places, the one at Lixmount, near Newhaven Station, and the other at a point a little nearer Leith. These two short lines unite at a short distance, and following a south-easterly course, the new line passes through Blair Park and beneath Ferry-road, after which it crosses by heavy bridges first the North British Railway, and then the Water of Leith. The line proceeds on a brickwork viaduct. The Bonnington-road is crossed diagonally by a skew bridge, and the contract terminates in the grounds of Pilrig. In the short mile described there is not only a good deal of heavy cutting, but seven bridges, a viaduct, and three foot bridges over the line have to be erected. The other contracts, which have not yet been let, will carry the line in an easterly direction, by way of Craigenlenny, to a terminal fork, the one branch ending to the east of the Edinburgh Dock at Leith, and the other branch ending at a proposed goods station on the site of the Bath-street soapworks.

A stained-glass window, in memory of the late rector, the Rev. W. H. E. McKnight, has been placed at the east end of Silk Willoughby church, near Sleaford. It has been designed and executed by Mr. C. Whall, at a cost of £300.

Mr. Thomas J. Brady has been appointed as superintendent of buildings for the boroughs of Manhattan and Bronx, near New York. Mr. Brady was for six years in charge of the Building Department of New York.

A Local Government inquiry was held at St. Austell on Thursday last week by Col. Hepper, relative to the application by the urban district council for sanction to borrow £1,275 for the acquisition of public offices and a fire station.

New business premises have been erected on the sites of three houses in Fore-street, Ipswich, for a firm of ironmongers. The buildings are three stories in height, and have been erected by Messrs. Thomas Parkington and Son, from designs by Mr. Thomas V. Cotman, also of Ipswich. A supper to the workmen engaged on the job was given on Wednesday week.

The town council of Godalming have decided to purchase the Public Hall and Stone House for £3,525, as a site for proposed municipal buildings to be erected at an estimated cost of £10,000. They have also determined to advertise for competitive plans from architects, offering a premium of fifty guineas for the design should it not be carried out. A letter was received from Mr. S. Welman, of Godalming, stating that in 1887 he was instructed by the council to obtain particulars for municipal buildings, and he did so, preparing plans, designs, estimates, and reports for several sites. None of that work had ever been paid for, and the only compensation he had had was the expectation that when the buildings were proceeded with, he should be allowed to continue the work upon which he had already bestowed so much thought. No action was taken.

The whole of the work to be carried out in connection with the restoration of Wesley's House, including the outfit, the new roof, and the entire reconstruction of the basement in concrete, with underpinning of foundations, will cost £1,080, or £480 in excess of the original estimates. The Wesley's House Committee, however, have unanimously resolved to face the entire outlay. The contract has been entrusted to Messrs. Holloway Brothers, of Battersea, and the works, including the decorative sections, which will be in 18th-century style, are to be carried out under the direction of Messrs. Gordon, Lowther, and Gunton, architects, of Blomfield-street, E.C.

A Bill will be introduced into Parliament next session to incorporate a company with powers to construct an underground electric railway at Brighton, from a point near the terminal station of the London, Brighton, and South Coast Railway Company to a point under King's-road, but with openings under the parade communicating with the beach. The total length of this railway will be five furlongs 7-25 chains, and the capital proposed to be raised for its construction is £120,000. The maximum fare proposed to be charged is 2d. for the whole distance.

## COMPETITIONS.

**SOUTH KIRKBY.**—In a limited competition for a new Wesleyan church and Sunday-schools at South Kirkby, near Pontefract, the design of Mr. Geo. F. Pennington, M.S.A., of Central Chambers, Castleford, has been accepted. The building is designed in the Late Gothic style, and has accommodation on the ground floor for 250 and an end gallery for 100. The school will also seat 200. Also choir and preacher's vestries are provided. The cost will be about £1,500.

**WESTMINSTER.**—For the Poster Competition in connection with the forthcoming Art Metal Work Exhibition at the Royal Aquarium, Westminster, the following members of the Council of the Exhibition have been elected judges:—Messrs. George Frampton, A.R.A., Lewis F. Day, George C. Haité, Maurice B. Adams, Ellis Marsland, and Josiah Ritchie. Professor Banister Fletcher, the chairman, is ex-officio a member of this committee of judges. The designs are to be received on Feb. 28.

## CHIPS.

The restoration of the parish church of Wellington, Salop, has been decided upon. The church will be closed after Easter Sunday. The architect will be Mr. C. R. Dalgleish, of Wellington, who will carry out the work, with Sir Arthur W. Blomfield, A.R.A., as consulting architect.

Professor Francis W. Chandler, of the Massachusetts Institute of Technology, has been appointed as the chief architectural supervisor of Boston, Mass. The architectural division is taken from the buildings department and attached to the engineering department of the city. During the past year Professor Chandler has been architectural adviser to the mayor.

A new academy, erected by the Leith School Board on the site of the old Leith High School at the south-west corner of the Links, was opened for teaching about a week ago. Mr. Craig is the architect.

Admission will be by ticket only on the occasion of the opening of the new building of the Passmore Edwards Settlement, Tavistock-place, to-morrow (Saturday), at 8 p.m. Applications for tickets should be made by letter to the Warden.

In the case of Joseph Goode, of Fernlea-villas, Palmerston-road, Walthamstow, E., builder, the order of discharge from bankruptcy has been suspended for two years ending Jan. 13, 1900. In that of Joseph Edwards and Robert John Edwards (trading as Edwards Brothers), of Lingfield, Surrey, builders, the order of discharge has been suspended for three years ending Jan. 19, 1901.

The vicar of St. James the Great, Bethnal Green, is appealing for £4,000 with which to carry out the necessary works of restoration. "The church," he says, "is practically unfit for service. There are great holes in the roof—the stonework will have to be renewed—and such things as lead-work, pipes, gutters, &c., are either gone or broken. Internally the plaster has fallen down from the ceilings—damp and mould disfigure the walls—and a heating apparatus must be supplied."

The London Technical Education Board has made a special grant of £1,000 towards the erection of the new workshops for masons' and plasterers' classes which are to form part of the buildings associated with the great hall of the Battersea Polytechnic. A donation of £100 has also been made by the Cloth-workers' Company towards the building fund for the hall. The buildings are to be proceeded with at once; but £1,400 is still required to meet the cost, so that the new building may be opened free from debt. The hall is designed to seat about 1,000 persons, and the estimated cost is £6,500.

Colonel W. R. Slacke, R.E., Local Government Board Inspector, held an inquiry at the Public Offices, Egremont, on Friday, into an application by the Wallasey District Council for power to borrow £930 for public pleasure-grounds.

A new wing is being added to Cardiff Castle for the Marquis of Bute, to contain a suite of state apartments. The plans have been prepared by Mr. Frame, and the contractors are Messrs. W. Thomas and Co., of Cardiff.

The partnership hitherto subsisting between T. S. Tilley, E. J. Tilley, and G. C. Tilley, general contractors and artisan well engineers, Walbrook, E.C., and Walbrook Works, Cambridge-road, E., under the style of Thomas Tilley and Sons, has been dissolved so far as regards T. S. Tilley.

The school board for Dundee have raised the salary of their architect, Mr. Langlands, from £30 to £100 a year. This is to cover the work of general superintendence and attention to repairs and alterations, he being paid, as hitherto, a commission on new works.

**TO CORRESPONDENTS.**

[We do not hold ourselves responsible for the opinions of our correspondents. All communications should be drawn up as briefly as possible, as there are many claimants upon the space allotted to correspondents.]

It is particularly requested that all drawings and all communications respecting illustrations or literary matter should be addressed to the EDITOR of the BUILDING NEWS, 382, Strand, W.C., and not to members of the staff by name. Delay is not unfrequently otherwise caused. All drawings and other communications are sent at contributors' risks, and the Editor will not undertake to pay for, or be liable for, unsought contributions.

Cheques and Post-office Orders to be made payable to THE STRAND NEWSPAPER COMPANY, LIMITED.

**TERMS OF SUBSCRIPTION.**

One Pound per annum (post free) on any part of the United Kingdom; for Canada, Nova Scotia, and the United States, £1 6s. 0d. (or 6dols. 90c. gold). To France or Belgium, £1 6s. 0d. (or 93fr. 90c.). To India, £1 6s. 0d. To any of the Australian Colonies or New Zealand, to the Cape, the West Indies, or Natal, £1 6s. 0d.

**ADVERTISEMENT CHARGES.**

The charge for Competition and Contract Advertisements, Public Companies, and all official advertisements is 1s. per line of eight words, the first line counting as two, the minimum charge being 5s. for four lines.

The charge for Auctions, Land Sales, and Miscellaneous and Trade Advertisements (except Situation advertisements) is 6d. per line of eight words (the first line counting as two), the minimum charge being 4s. 6d. for 40 words. Special terms for series of more than six insertions can be ascertained on application to the Publisher.

Front-page Advertisements 2s. per line, and Paragraph Advertisements 1s. per line. No Front-page or Paragraph Advertisement inserted for less than 6s.

Advertisements for the current week must reach the office not later than 3 p.m. on Thursday. Front-page Advertisements and alterations in serial advertisements must reach the office by Tuesday morning to secure insertion.

**SITUATIONS.**

The charge for advertisements for "Situations Vacant" or "Situations Wanted" is ONE SHILLING FOR TWENTY-FOUR WORDS, and SIXPENCE for every eight words after. All Situation Advertisements must be prepaid.

**NOTICE.**

Bound copies of Vol. LXXII. are now ready, and should be ordered early (price Twelve Shillings each), as only a limited number are done up. A few bound volumes of Vols. XXXIX., XL., XLI., XLVI., XLIX., LI., LIII., LVIII., LIX., LXI., LXII., LXIII., LXIV., LXV., LXVI., LXVII., LXVIII., LXIX., LXX., LXXI., LXXII. may still be had, price Twelve Shillings; all the other bound volumes are out of print. Most of the back numbers of former volumes are, however, to be had singly. Subscribers requiring any back numbers to complete volume just ended should order at once, as many of them soon run out of print.

LANDLORD. (The obvious way is to consult a respectable architect.)

RECEIVED.—D. R. and Co.—N. O.—L. F.—M. and Son.—A. S. C.—P. B.—L. H.

**"BUILDING NEWS" DESIGNING CLUB.**

**FIFTH LIST OF SUBJECTS.**

E.—A Small Convalescent Home for 24 men, by the seaside, on a site overlooking the shore at the head of the cliff, where the land is practically level. The position is exposed, and the building, which is to be built in local coursed stone, must be planned accordingly. The aspect is south-west on the sea-front side. The accommodation is to provide a dining-room, recreation-room, small writing-room or library, two dormitories, a superintendent's residence, comprising parlour, adaptable as an official room, a living-room 14 by 14, or of that area, a kitchen, scullery, and offices. A bath-room with two baths, lavatory with 12 basins; five w.c.'s and urinals, for the use of the inmates; also a boot-room, cloak-room, and box-room. The whole of the accommodation is to be provided on the ground floor, excepting one dormitory and the superintendent's two bed-rooms and two bed-rooms for the female servants. A house-yard and small laundry, well separated from the patients' departments, to be provided. The building is to be suitable for 24 men, exclusive of the staff. The roofs to be covered with tiles. The style is to be suitable for stone. Two plans, two elevations, one section, and a view. Scale, 8ft. to the inch for elevations. Plans and section may be drawn to 16ft. to the inch.

DRAWINGS RECEIVED FOR MOUNTAIN CHURCH.—"Lany," "Hotspur," "Chuckle," "Olliwops" (no name and address), "Tee Square," "Phantom."

**Correspondence.**

**CALIFORNIA UNIVERSITY COMPETITION.**

To the Editor of the BUILDING NEWS.

SIR,—The Royal Institute of British Architects has been desired by the Marquess of Salisbury to give publicity to the international competition for the Phebe Hurst Architectural Plan of the University of California.

In consequence of this request, I should esteem

it a favour if you would give me the opportunity of stating in your columns that programmes of the competition, together with maps of the site, can be obtained on application to the Secretary of the Royal Institute of British Architects, and that further photographs and a plaster relief map of the site are on view in the library of the Royal Institute.—I am, &c.,

W. J. LOCKE, Secretary.

9, Conduit-street, London, W., Feb. 9.

**QUANTITIES AND TENDERS.**

SIR—The inclosed correspondence is of such vital interest to architects who take out their own quantities, to the public whom they serve, and especially to public bodies who must by law advertise for tenders, that I venture to send it to you for publication.—I am, &c.,

ROBERT WILLIAMS.

17, Effingham-road, Lee, London, S.E., Feb. 3, 1898.

(I.)

17, Effingham-road, Lee, London, S.E., Sept. 17, 1897. DEAR SIR,—May I ask you to be so kind as to draw the attention of some of your members to the inclosed advertisement for tenders for the new wards at the Lewisham Infirmary?

May I also ask you to kindly let me know whether your Association has any rule with regard to advertised tenders? My reason for this is that some of the best London builders have written to me that (a) they have "found it necessary to make it a rule not to tender for advertised work"; and (b) "that the forms of tender are generally such as we cannot agree to."

Do you issue reports and lists of members as the R.I.B.A. does? And if so, and I might, I would be glad, by payment, of course, to obtain a copy.—Yours faithfully,

ROBERT WILLIAMS.

R. S. Henshaw, Esq., Secretary to the Builders' Institute, 31 and 32, Bedford-street, Strand, W.C.

(II.)

31 and 32, Bedford-street, Strand, W.C., Sept. 18, 1897. DEAR SIR,—I am obliged by your letter of the 17th inst., which shall be laid before my council at their next meeting. The Institute does not issue lists of members and reports, therefore I regret I cannot supply you with one.—Yours faithfully,

R. S. HENSHAW, Secretary.

Robert Williams, Esq., 17, Effingham-road, Lee, S.E.

(III.)

Oct. 20, 1897. DEAR SIR,—Your letter of the 17th inst. [September R.W.] was laid before the council of this Institute at their last meeting, and I am desired to say in reply to your first inquiry as to whether the Institute has any rule with regard to advertised tenders, that they have not.

There is no doubt but that as a rule leading builders in London do not tender for works which are publicly advertised, for this reason: that they do not consider the competition equal, as it is open to anyone to tender, and there is consequently a great deal of reckless tendering, and substantial men in very many instances find it a mere waste of time.

In reply to the last paragraph of your letter, the reports and lists of the Institute, and also of the Central Association, are private, and confined to its members.

In reference to the advertisement itself (no responsibility for which they conclude rests with yourself), they desire to say that the terms are not such as to induce responsible builders to take any trouble in reference to the matter.

It is impossible to express any opinion as to the form of tender, as it is not before them; but they consider there is the greatest objection to tendering upon bills of quantities prepared by the architect, and though there is no rule in the Institute, there is a general understanding that bills of quantities should be prepared by a properly qualified independent surveyor.—Yours, &c.,

Robert Williams, Esq., R. S. HENSHAW, Secretary.

[\* See copy at end.]

(IV.)

Oct. 20, 1897. DEAR SIR,—Allow me to thank you for your reply to my letter of September the 17th. I note your remarks about the advertisement for tenders for the Lunatic Pavilion at Lewisham, and beg to say that the copy was shown to me for approval, and, as I could see nothing in it of which I could not approve, I would be extremely glad (for future guidance) if you would kindly ask your Association to point out specifically what the objectionable terms were.

The last paragraph in your letter contains a statement of the most serious moment to architects who take out their own quantities. Would you, therefore, kindly ask your Association to be so kind as to inform me why "they consider there is the greatest objection to tendering upon bills of quantities prepared by the architect"? The paragraph ends by stating that "there is a general understanding that bills of quantities should be prepared by a properly qualified independent surveyor." Am I to understand from this that there are no architects "properly qualified" for taking out quantities?

I beg to inclose a copy of the form of tender,† to which reference has been made, and would be very thankful for your Association's remarks thereupon. Hoping you will convey my thanks to your Association,—I am, &c.,

R. S. Henshaw, Esq. ROBERT WILLIAMS.

[† See copy at end.]

(V.)

Oct. 25, 1897. DEAR SIR,—I must apologise for not having previously acknowledged your letter of the 20th inst. It shall be placed before my council at their next meeting.—I am, &c.,

Robert Williams, Esq. R. S. HENSHAW, Secretary.

(VI.)

Nov. 8, 1897. DEAR SIR,—In reply to your letter of the 20th ultimo, I am directed to say that in reference to the first part of your letter, the observation was intended to apply in a general way to such advertisements, and not particularly to the one in question.

Replying to the other part of your letter, the objections to an architect acting as quantity surveyor and architect on the same work must be obvious, and does not involve the question of qualification at all. The practice, if not against any rule of the Royal Institute of British Architects, is certainly disapproved by its leading members—in the London district, at any rate. There is nothing in the form of tender except so far as it contains reprints previously referred to as objectionable.—I am, &c.,

Robert Williams, Esq. R. S. HENSHAW, Secretary.

[† Every graduate—i.e., certificated by examination, member of the R.I.B.A.—is examined in taking off quantities, measuring, and estimating. Clause 15 of "Professional Practice" specifically mentions quantities as part of the architect's work.—R. W.]

(VII.)

Nov. 9, 1897.

DEAR SIR,—Allow me to acknowledge with thanks, your letter of yesterday's date in reply to mine of Oct. 20th. May I point out to you that you do not answer my earnest request to know why "they (the builders) consider there is the greatest objection to tendering upon bills of quantities prepared by the architect"?

You only tell me now that "the objections to an architect acting as quantity surveyor and architect on the same work must be obvious."

Now, a "grave objection," I confess, ought to be obvious; but to me it is not, and I still, respectfully, ask that the grave objection might be pointed out.

As an architect properly qualified to take out his own quantities, and who does so, I am, as far as I can gather, precluded from receiving tenders from members of your society. To be ostracised in this way seems to me to be a grave matter indeed, and I would be glad if you would kindly see your way to furnish me with a definite reason for this action.—Yours,

R. S. Henshaw, Esq.

ROBERT WILLIAMS.

(VIII.)—RE TENDERS, ETC.

Jan. 28, 1898.

DEAR SIR,—May I point out to you that I have not yet received a reply to my letter to you of Nov. 9, 1897?

It is very important that I should have a reply, because it appears to me, from your letter to me of Oct. 20, that, as regards the mode of my carrying out my professional practice, I have the choice of two alternatives—cease from taking out my own quantities, or, have my jobs boycotted by the members of your society.

As this subject and this position is of great moment to practising architects (and I am sure you will admit this), it is my intention to publish these letters, and I would, therefore, esteem it a kindness if you favoured me with a reply as soon as possible.—I am, &c.,

R. S. Henshaw, Esq.

ROBERT WILLIAMS.

(IX.)

Feb. 2, 1898.

DEAR SIR,—Your letter of the 28th ultimo was laid before my council yesterday, and I was directed to say that when they replied to your first communication on the 20th October last, they had no idea or intention of engaging in a controversial correspondence extending over a considerable period. You asked them for information in reference to a difficulty you had experienced, which they presumed was a practical difficulty, and to the best of their ability they gave you information upon the points involved. Your letters of Nov. 9 and Jan. 28 being so controversial, my council prefer leaving them unanswered.—Yours, &c.,

Robert Williams, Esq.

R. S. HENSHAW, Secretary.

(X.)

Feb. 3, 1898.

DEAR SIR,—Thank you for your letter of yesterday's date. A reference to your former letters and to the dates thereof will show you that neither the "controversial" nor the "extending over a considerable period" character of the correspondence was caused by any question raised by me or delay of mine.

In publishing these letters, I must express strongly my regret that your Council is unable to give me a reason for stating that "there is the gravest objection to tendering upon bills of quantities prepared by the architect, and though there is no rule in the Institute, there is a general understanding that bills of quantities should be prepared by a properly qualified surveyor."

Although I pointed out to you that architects were properly qualified (none ought to be more so), you were unable to give me a reason, but said that the grave objection was "obvious." The matter was thus shown to be not altogether one of qualification, as you, indeed, admit. This question of quantity-taking affects hundreds, probably thousands, of architects, and the question of not tendering affects all public bodies, who have to advertise if the contract be above 50.

Personally, as the correspondence shows, I have been refused tenders, and, so far as I can see, I must conform with the "general understanding" of your Institute, or my practice and living come to an end, so far as your Institute is concerned.

R. S. Henshaw, Esq.

ROBERT WILLIAMS.

**LEWISHAM UNION. ERECTION OF LUNATIC WARDS. TO BUILDERS AND CONTRACTORS.**

Notice is hereby given that the Guardians of the Poor of the Lewisham Union will meet at the Union Offices, Lewisham, on MONDAY, the 27th day of September, 1897, at 4.30 p.m., to consider TENDERS from persons willing to CONTRACT for the ERECTION OF LUNATIC WARDS at the Infirmary, High-street, Lewisham, according to plans and specification to be seen at the office of the Guardians' Architect, Mr. Robert Williams, 17, Effingham-road, Lee, S.E., on any week-day, except Saturday, between 10 a.m. and 4 p.m.

No tender will be received unless made out on one of the lithographed forms, which, together with a copy of the bills of quantities (prepared by the said architect), may be obtained at the office of the said architect, upon depositing with him the sum of £1 1s., which will be returned upon the receipt of a bona-fide tender for the works.

The Guardians do not bind themselves to accept the lowest or any tender.

Tenders must be signed and inclosed in envelopes duly sealed with sealing-wax, and endorsed "Tender for Lunatic Wards," and delivered at the Union Offices, Lewisham, not later than 4 p.m., on the said 27th day of September.

The person who may be accepted as the contractor must be prepared to enter into a bond with two sureties (to be named by him for approval) for the performance of

his contract in such an amount as the Guardians may determine.—By order,  
H. C. MOTT,  
Union Offices, Clerk to the Guardians.  
286, High-street, Lewisham, S.E., Aug. 10, 1897.

#### A TENDER +

For erecting the proposed Lunatic Wards at the Lewisham Union Infirmary in the High-street, Lewisham, S.E.  
To the Guardians of the Poor of the Lewisham Union in the County of Kent.

Ladies and gentlemen, willing to carry out the above works in accordance with the Drawings, Conditions, Specification and Quantities prepared by the Guardians' architect, Mr. Robert Williams, F.R.I.B.A., and to complete the same to his entire satisfaction within a period of ..... months from the date of signing of the contract, if not prevented by unforeseen circumstances, for the sum of ..... (£ ..).

And ..... submit the following names as Sureties for the due performance of the contract.  
Name ..... Name .....  
Address ..... Address .....

This Tender is delivered with the knowledge that the Guardians do not bind themselves to accept the lowest or any Tender.

(Signed) .....  
(Address) .....

Date September ..... 1897.

N.B.—Sealed Tenders endorsed "Tender for Lunatic Wards" are to be delivered at the Union Offices, 286, High Street, Lewisham, S.E., on or before the 27th day of September, 1897, at 4 p.m.

## Intercommunication.

### QUESTIONS.

[1897].—**Penalties for Delay.—Liquidated Damages.**—Can anyone inform me what instances there may be of penalties for delay having been enforced? I have a case in hand. Considerable delay in finishing work has been incurred, and the builder smiles at the idea of the penalty clause, saying such is never enforced. If any of your readers can give instances, naming amount for week or day, total amount deducted, name of building, locality, architect, &c., I shall feel greatly obliged?—NEMO.

[1898].—**Paint for Oak Joinery Work.**—A client of ours wishes his oak joinery work left natural off plane irons—viz. without any stain, polish, or filling in. We think oak joinery should be protected by something artificial, even if only filled in; but this will not be allowed. Can any reader suggest a treatment that will leave the oak to all appearances natural, and at the same time protect it?—A BUILDER.

[1899].—**Damp-proof Course.**—In a villa which has been built nine years the internal plastering is breaking off up to about 2ft. from the floor, owing to the damp rising. I find the damp-course is of blue bricks set in cement. Can anyone advise me what is the best thing to do to put a stop to this?—A. S. C.

[1900].—**Waterproofing Rough-Cast.**—A west random rubble-stone wall (18in. thick) rough-cast, in a most exposed position, is penetrated, in patches, during continuous drifting rain. Is there any solution which would not materially change the colour of the rough-cast which will render it rain-proof under all conditions?—ENQUIRER.

[1901].—**Damp Wall.**—The 9in. walls of a house built some three years since, and facing south-west, are very wet, doubtless due to the porosity of the facing-bricks, for the dampness only occurs where these have been used. The brickwork has been treated with a patent solution, but without any benefit. Can any reader suggest a practical remedy? The tenant objects to have the outside plastered.—P.

### REPLIES.

[1898].—**Light.**—If the building erected be at the extremity of your land, the owner of the adjoining land can then demand a yearly payment for the enjoyment of such light and his own protection. Should there be any air space, such as a roadway or footpath, between your building and his land, which be yours, then you are not bound to pay him anything. Should your building be at the extremity of your land, as before mentioned, and you refuse to make yearly payment, he can then take steps to force you to block the light up, as it would depreciate the value of his land.—A. C. F.

[1898].—**Light.**—If the owner of adjoining land has enjoyed an undisputed freedom from windows overlooking his land, I should advise "Mackenzie" to pay the 5s. as acknowledgment for the enjoyment of such light. Were there any windows overlooking the land before the warehouse was built? If so, you have probably a prescriptive right (if more than 20 years), and your neighbour cannot interfere with your lights; but if there were no windows overlooking, your neighbour is right in asking for a payment, or otherwise in blocking out your light, because should your warehouse acquire a 20 years' right, you should your neighbour acquire a 20 years' right, because of light over his land, you can prevent him from building to obstruct your light. He is only acting in self-defence. You do not state how long the land adjoining has been vacant, or whether there were windows overlooking it, or how long.—AN ARCHITECT.

[1889].—**Protection of Iron.**—I should recommend "A. C. D." to use the "Angus" process, if possible. This is applied to the iron casting on all sides while hot. If it is an iron pipe, both the inside and outside should be coated. There are several new kinds of paint used for ironwork, but experience is wanted in estimating the value of them. Engineers now largely employ Dr. Angus Smith's process. For stable fittings, iron pipes, it has been used with good results. The ironwork is thoroughly scraped or cleansed from rust, and then it is dipped at a high temperature in a mixture of coal-tar, pitch, and linseed oil. This admixture coats the surface with a tough, bituminous, and firmly adherent substance, which

does not peel off if the heat of the iron is maintained.—G. H.

[1889].—**Protection of Iron.**—The cause of paint peeling off iron is due to the oxidation of the iron surface. Such oxidation, unless it occurs under a coat of paint, is due to the elimination of glycerine from the oil vehicle which has been used in grinding up the pigment. Glycerine is the part to which the fatty acids of the oil are united; these fatty acids combine more or less with the pigment, and the glycerine is set free. This free glycerine cannot escape through the dry skin of paint, so it is driven to the posterior surface of the coat of paint, and then comes in immediate contact with the metallic iron. As a consequence, instead of the coat of paint being firmly attached to the iron (like paint is when laid on wood), there is a layer of fluid glycerine beneath, which prevents the paint adhering. Hence, when the coat of paint has dried and hardened, it readily flakes or peels off. Besides this mischief, the glycerine causes the metallic iron to rust (*i.e.*, becomes oxidised), and, as a result, there is a film of pulverulent iron rust beneath the coat of paint, which also decreases the adherence of the paint to the metallic surface. Red-lead paint is considered to be the best for painting iron surfaces, and, from a chemical point of view, it is so, because red lead, when ground up in linseed oil, combines with about 7ths of the glycerine which is eliminated, and thus decreases the amount of mischievous glycerine beneath the skin of paint. The nearest approach to a perfect paint for iron surfaces the writer ever came across is "Ferronor." This paint will adhere to any metal, and as a proof of its indurability by chemical agents, the makers coat sheets of zinc with the paint, then steep the zinc in acids until the zinc is dissolved away, when the skin of "Ferronor" paint is left in a thin leaf or layer of paint, pure and simple.—H. C. S.

[1890].—**Cement Tests.**—The results, published in the *Journal* of the Clerk of Works' Association of Jan. 28, that have been obtained from Portland cement mortar briquettes, may perhaps be of interest to your inquirer. The briquettes were made while the Portsmouth sewage outfall works were in progress to a specification by Sir Frederick Bramwell, Bart., F.R.S., and Mr. H. Graham Harris, M.Inst.C.E., the work of making them being intrusted to my care.—WILLIAM BAKER, 1, Chetwynd-road, Southsea.

[1890].—**Cement Tests.**—"G." will find notices of recent tests in the *Building News* of the last year; but a good Portland cement of the requisite fineness, weight, and time of setting will be sufficient to insure strength or hydraulic properties. Consult Fajja's or any modern handbook.—PRACTICE.

[1891].—**Payments under Contracts.**—In some contracts payments are made at the rate of 75 per cent. from the date of delivery of goods, and the remaining 25 per cent. within, say, two months of the completion and delivery of the goods. The clause of conditions ought to state further that the castings and all bolts and fittings be supplied in accordance with the drawings and details and to the architect's satisfaction, who is to have power to reject any unsound casting or faulty material; all such defective materials and work so condemned to be replaced by the contractor to the architect's satisfaction. In default, the architect is to be at liberty to terminate contract, and to enter into any new contract for the completion of the work, and for the manufacture and supply of other castings, patterns, &c., without prejudice to any right of action by the employer against the contractor in respect of his default, and any amount due to him, or any material and plant on the site, shall be forfeited by him. These are the principal conditions required in any clause of the kind.—G. H. G.

[1891].—**Fire grate.**—Our patent Manchester grates are just what your correspondent requires, having a warm-air chamber fed by inlet from inside, and provided with means for warming the room above. These grates have a firebox lined with firebricks. They are in use in buildings of every class throughout the country, and are the best grate of the kind we know of.—E. H. SHORLAND AND SON.

### CHIPS.

The bust of Lord Randolph Churchill, subscribed for by members of the House of Commons, is now ready to be placed on its pedestal at Westminster.

A new high altar was opened at St. Alexander's Roman Catholic Church, Bootle, last Sunday. The altar, which is very elaborate, has been erected from the design of Messrs. Pugin and Pugin, at a cost of over £1,200.

An oak pulpit was dedicated, on Friday evening, in the church of St. Mary, Bickington. It has been erected to the memory of the late Mr. John Bickford, of Wrigwell, Newton Abbot, for many years churchwarden, and is the work of Messrs. Harry Hems and Sons, of Exeter.

At the meeting of the Colne Town Council on Tuesday the chairman of the technical instruction committee stated that it was practically settled that the provision of new technical schools and a public library should now be undertaken with the corporation's consent upon the amended plans submitted by Messrs. Woodhouse and Willoughby, Manchester, at a cost of £10,000. The site selected was in Albert-road. The minutes were confirmed.

The first new buildings erected for intermediate school purposes in the county of Montgomery have been opened at Llanidloes. The new school, which is situated on the banks of the Severn, in ample recreation ground, provides accommodation for 78 students. It includes an assembly-hall, an art-room with top light, large laboratory, cooking and laundry-room, &c. The contractor was a local builder, Mr. W. J. Jones-Meredith, of Llanidloes, the cost of the erection being £2,150, and the architect was Mr. H. Teather, of Cardiff.

### LEGAL INTELLIGENCE.

RE DREW-BEAR V. GUARDIANS OF ST. PANCRAS.—The Hon. Mr. Justice Ridley has sent an intimation that he will give judgment in this case on Friday, the 11th inst. (to-day), at 10.30 a.m., at No. 2 Court, Queen's Bench Division.

A BUILDING ACT PROBLEM.—At Guildhall Police-court on Tuesday, before Mr. Alderman Truscott, Mr. Edmund Woodthorpe, district surveyor of the northern division of the City, appeared to a summons at the instance of Messrs. Mason and Co., of the Barbican, the building owners of premises at 19, Australian-avenue and 1, Cotton-street, who were dissatisfied with his decision as to certain work to be done upon the premises, which was alleged to be in contravention of the London Building Act, 1894. Mr. J. R. Atkin appeared for the appellants and Mr. Woodthorpe conducted his own case. Mr. Atkin said that Messrs. J. B. Coates (the Central Agency) were the occupiers of the basement and the first and second floors of 1 and 3, Cotton-street, and as the business expanded they wanted to take the ground-floor of No. 18, Australian-avenue, and, in order to do so, though these were originally separate buildings, they were desirous of having only one ground-floor. To this Mr. Woodthorpe had given notice of objection, arguing that the place was not fit for one occupation. Now, the only object of this particular section of the Act was protection against fire. He submitted that the taking of a room at 18, Australian-avenue would in no way increase the danger in case of fire, and the premises were adapted for one occupation, thus meeting the construction of the Act. Mr. Flint, A.R.I.B.A., was called, and said these premises could be made to connect, and were adapted for one occupation. The risk by fire would be no greater, with the iron door it was proposed to place in the room. Mr. Woodthorpe held to his original notice. The Alderman remarked that he had paid great attention to this matter. He had visited the premises, and had left nothing undone that would assist him in arriving at a right decision. He came to the conclusion that he must uphold the notice of the district surveyor, but did so with considerable regret. He would be glad to state a case on the point, as the Building Act seemed to him a difficult problem.

A BUILDER HEAVILY FINED.—At the Ipswich Police-court on Monday, Thomas Parkinson, jun., builder, Crown-street, was summoned for omitting to lay drains as required by the by-laws. Mr. W. Bantoff, town clerk, prosecuted on behalf of the corporation, while Mr. S. A. Notcutt appeared for the defendant. Mr. Bantoff said that the sanitary inspector, finding a nuisance existed at St. Margaret's Coffee House, directed certain alterations in the drainage of the premises. The carrying out of these alterations were intrusted to the defendant, who was to put down watertight drains in a bed of 6in. of cement. When the drainage inspector visited the premises on January 27, he was somewhat suspicious as to the depth of the cement. The workman stated that it was the proper depth, but the inspector, on putting a shovel down by the side of the pipes, found that there was not more than 1½in. of concrete. Finding also a pipe with a broken flange, he had two others taken up, with the result that he found they were broken to even a greater extent. The bad work was done under the living-rooms of the house. Mr. Bantoff mentioned that the committee were unanimously for a prosecution, and added that he was told to ask for the maximum penalty. Arthur Hicks, inspector of nuisances, and Geo. Aylward, drainage inspector, gave evidence in support of Mr. Bantoff's statement. Mr. Edward Buckham, borough surveyor, deposed to visiting the premises, while Mr. G. S. Elliston, medical officer of health, said the defect was a serious one, and likely to have an injurious effect upon the health of those who lived in the rooms. Mr. Notcutt, in expressing regret on behalf of the defendant that the pipes should have been laid improperly, said that defendant's father undertook to superintend the work for his son. Nothing was said in the by-laws as to the pipes being laid in a bed of cement, and he submitted that as the joints were watertight there was no case to meet. The magistrates imposed the full penalty of £5, with £12s. 6d. costs.

TIMBER MERCHANT'S ACTION AGAINST AN ARCHITECT.—Before Mr. Commissioner Kerr and a jury, the case of Houghton Bros. v. Clark was heard on Wednesday week. Messrs. Houghton Bros., timber merchants, 24, Devonshire Chambers, Bishopsgate-street, sought to recover the sum of £50 3s. 3d. (the action having been remitted from the High Court of Justice) for timber supplied to the defendant, Mr. J. W. Clark, Peterboro-road, Harrow. In opening the case, Mr. Bartley said that the sum claimed was the balance of about £150 for timber which had been supplied by the plaintiffs upon the defendant's authority. The defendant was an architect, and the timber was supplied for the purpose of being used at St. Kilda-road, Harrow, where the defendant was engaged upon the erection of certain houses. The defence raised, shortly, was that the defendant neither ordered the timber nor received

it, and that a man named Pay, the builder of the houses, was actually responsible, he having personally given the orders. The real point which the jury would have to determine was whether Pay was the authorised agent of the defendant for the purpose of ordering the timber. In June, 1896, Pay was an undischarged bankrupt, and the plaintiffs were his largest creditors in the bankruptcy. Consequently, they knew all about his position. Pay had an interview with the defendant in regard to the building of seven houses in St. Kilda-road, Harrow, three of which were to be built for a Mr. Smith, and the other four for a Mr. Cooper. They were to cost in all something over £2,000. The defendant suggested that Pay should enter into a contract to build the houses, the defendant agreeing to advance the money required, the profit to be divided. That suggestion was declined by Pay, who eventually agreed to build the houses as the defendant's manager. For some reason the defendant did not desire his name to appear in the matter. That being so, Pay ordered the timber and other goods needed, and the defendant had made payments on account. Now he had declined to pay the balance due. Mr. Pay, builder, Thurstgrove, South Norwood, was called, and said he was still an undischarged bankrupt. He called on the defendant in answer to a letter, and agreed to build the houses as his manager. The arrangement was that the defendant should finance him. The defence was that defendant never gave the man Pay any authority to pledge his credit, and he did not know that it was being done. The plaintiffs never communicated with him in any form to intimate to him that Pay was ordering the timber in his (defendant's) name. Pay had no business to do anything of the sort. Mr. Commissioner Kerr told the jury that the simple question was, "to whom were the goods sold?" The parties consented to take the verdict of the majority, which was in favour of the defendant on all points. Judgment was entered for the defendant accordingly, and his costs of the litigation were allowed.

**DISPUTE BETWEEN ARCHITECTS.—**HOFFMAN V. HALLEY.—This claim, heard in the Lord Mayor's Court on the 2nd inst., was made by the plaintiff, an architect, to recover £400 odd from the defendant, also an architect, in respect of professional services rendered in connection with certain property at Barnes. In October, 1896, the defendant was desirous of erecting six blocks of mansions at Castelnau Estate, Barnes, and plaintiff was instructed to prepare plans. At the beginning of 1897 plans were prepared, and in respect of that item the plaintiff claimed 2½ per cent. on the estimated cost of the buildings to be erected (£3,500). The defendant expressed satisfaction with the plans, and requested the plaintiff to introduce a builder to carry out the work. A builder was introduced, and for that introduction the plaintiff claimed £150. The defendant afterwards saw the plaintiff, and said that he was very sorry, but he had altered his mind as to the class of property he proposed to erect upon the site at Barnes. The plaintiff afterwards prepared fresh plans in respect of the defendant's altered scheme, and, as the builder whom the plaintiff had already introduced refused to take up the matter, the plaintiff was asked to introduce another builder. That he did, and for that service he claimed £240, making altogether the amount claimed in the action £477 10s. The defendant ultimately refused to carry out the transaction, and had not paid the plaintiff for his services. During counsel's opening the learned Recorder (Sir Chas. Hall) suggested that a little temperate advice might be of use in putting an end to the dispute between brother professional men. A consultation took place between the parties, and defendant's counsel said the suggestion of the learned Judge had been accepted by his client. The defendant denied liability, but agreed to give the plaintiff a certain sum. There would be a verdict for the plaintiff for £100. The Recorder, in giving judgment, said he was sure the defendant had been well advised.

At Tuesday's meeting of the London County Council the debate was resumed on the proposal of the Fire Brigade Committee for a large increase in the stations and appliances of the brigade, at an estimated cost of nearly £200,000, which were agreed to, with the addition of a recommendation that the question of the method by which the fire brigade expenditure is to be defrayed be referred to a joint committee for consideration.

It is proposed to carry out the following schemes of church extension in the diocese of Chester:—St. Hilary's, Wallace, a new church, in the place of the present building known as St. Luke's, Poulton; St. James's, New Brighton, a new church, to seat 700 persons, at Upper Brighton; St. Mary's, Liscard, a new church, to take the place of the old mission-house at Liscard village; St. John's, Egremont, a new church at the bottom of Trafalgar-road, near the Presbyterian Church; St. Paul's, Seacombe, the mission-rooms to be enlarged and a new church to be built near the board schools, Poulton-road.

## Our Office Table.

A BLUE BOOK, just issued by the Department of Science and Art, states that the estimated total expenditure on technical education during the year 1896-7 in England and Wales was £807,864. In addition, the amount raised by loan on the security of the local rate, mainly for the erection of technical and science and art schools, was £131,164. In Wales and Monmouth the estimated total amount devoted annually to intermediate and technical education is £42,861. In Ireland the estimated total expenditure during 1896-7, under the Technical Instruction Acts and the Public Libraries Acts, was £4,658. There are now throughout the United Kingdom 169 schools of science in connection with the department. In 1896 there were 220 schools of art and a total of 56,175 students, the fees paid by the latter amounting to £35,770, and the payments on results to £45,610. There were 1,540 art classes, with 99,018 students. The payments on the results of art examinations in art classes and science classes together amounted to £27,613. There were 20,161 elementary day schools, at which 2,250,070 children and 18,209 pupil-teachers were taught drawing, the payments on the results of their examinations amounting to £176,224. The whole number of persons who received instruction in art in some form through the agency of the department was 2,445,785.

We do not know what apparatus is employed, but apparently mechanical ventilation is not appreciated by the members of the Bristol City Council, where, according to the *Western Daily Press*—

Mr. Abbot complained that they were being stifled, the ventilating fan not being in operation. The Mayor gave instructions for the matter to be seen to. Ald. Davies now asked leave to move the adjournment of the house until Tuesday next to the Guildhall. Really that council room was unbearable. Mr. Levy-Langfield begged to second that. Some confusion resulted. Complaints of the draughts were made by many members, and Mr. Pemble asked: Do you object, Mr. Mayor, to our wearing our hats? The Mayor: Order, order. Members sitting on that side of the room then closed the ventilators from which the cold air was descending. Mr. Pemble: Will you, Mr. Mayor, give instructions to stop the ventilating machine. I would rather stifle than be killed in this way. The draught is terrible. The Mayor: If you will kindly take your seat I will have the matter attended to. It was understood that the ventilating fan was then put at half speed and business was resumed.

If the choice is really between stifling and "draughts," the ventilation of the Bristol Council chamber is a problem still unsolved.

A FEW weeks since we published a view of Wells Cathedral, and we mentioned at the time that Messrs. Frost and Reed, of Bristol, were about to bring out a series of etchings of "The Church Towers of Somersetshire," from the hand of Mr. E. Piper, R.P.E. The first part of this publication has now been issued, with a descriptive introduction and notes written for the work by Mr. John Lloyd Warden Page. Wells Cathedral furnishes the frontispiece. The two remaining plates are in illustration of Axbridge Church and St. James's, Winscombe. The former is a cruciform building, and has a central tower, with a richly-pierced parapet and handsome south porch. The 17th-century plaster ceiling over the nave is an instance of incongruity which has found many admirers, the late J. D. Sedding among the rest. The 18th-century altar-cloth of tapestry is another treasure to be seen in this handsome church. Three miles from Axbridge is situate Winscombe Church, perched on a knoll below Shutshelf Hill, one of the spurs of the Mendips. The tower is somewhat too tall for its size; but it distinctly belongs to the district in the leading characteristics of its design, which much resembles that at Axbridge. It is 95ft. high, and the walls of the church, with the exception of the chancel, are enriched by pierced parapets, at once so general and so typical of the Somersetshire Perpendicular style of building. The three leading classes of tower design in Somerset are described as the Taunton, the Bristol, and the Wington types. The etchings in the volume before us are well produced, and the folio will find a welcome in many an artistic home, particularly in Somersetshire, for the drawings are faithful records, nicely executed. The letterpress has been written by one who has a wide knowledge of the architecture of his country.

The fourth annual dinner of the heads of staff of the firm of Young and Marten, Caledonian Works, Stratford, took place at the Holborn

Restaurant on Saturday, the 29th ult., with Mr. H. H. Marten, proprietor, in the chair, and Mr. E. Montague Edwards, general manager, in the vice-chair. Mr. Frank Marten and Mr. Ernest Marten were also present. Mr. E. M. Edwards, vice-chairman, stated, in proposing the health of "The Proprietor of the Business, and Success to the Firm of Young and Marten," that it was the toast of the evening, and he regarded it as an honour that he was privileged to propose it. He spoke of the achievements of the firm, and the name they had gained through supplying goods of sterling value at a nominal figure, and with promptitude and despatch. They had gained a position in the building world which was envied by many. The future success of the firm, he felt, was assured; the catalogue just completed, and now being distributed among the firm's *clientèle*, he considered, without speaking egotistically, was one of the finest and most comprehensive that had ever been attempted: eulogies from all parts were flowing in to headquarters, and the trade Press had spoken most encouragingly of it. The toast was drunk with musical honours. The chairman, in response, thanked Mr. Edwards for the kind remarks made in proposing his health, and also for the eulogistic expressions used in reference to the firm of Young and Marten, of which he had the honour to be the proprietor. Last year he expressed the hope that 1897 would be a record year, and he was glad to say the volume of trade done justified that hope, as they had had a considerable increase in their turnover. The chairman, in submitting the toast of "General Manager and Staff," said:—I have now to propose what I consider is the toast of the evening—that is, the health of your worthy vice-chairman and manager, Mr. Edwards, and the staff of Young and Marten. No general in the army could possibly have a more energetic and loyal body of men than I see around me this evening. I thank you most heartily for all your services, and I rejoice to think the same unity of spirit, respect, and esteem still exist between us. I assure you that all the good wishes I know you extend to me are heartily reciprocated by myself.—The vice-chairman, in replying to the toast of his health, and that of the staff, proposed by the chairman, said that he appreciated on his own behalf the kind words of encouragement which had fallen from the lips of Mr. Marten; he felt also that the staff would in a like sense appreciate them. Mr. Marten was at all times liberal in his treatment of difficulties, and an instance was cited which elicited cheers from those present.

## CHIPS.

The Sheffield City Council agreed, on Wednesday, to purchase the undertaking of the Sheffield Electric Light and Power Company.

The Examiner of the House of Commons passed on Tuesday the St. Helen's Corporation Bill for the construction of tramways at a cost of £50,000, and the extension of the boundaries of the borough.

At the meeting on Tuesday of the Wirral Rural District Council, the building surveyor (Mr. Hughes) asked for the direction of the council as to the control of the sewers, a difference of opinion having arisen between himself and the road surveyor (Mr. Davies) concerning some sewerage works at Ness. Captain Congreve asked if it was true that the road surveyor was the contractor for the council in laying that sewer. The chairman said that was not so; the contractor was the road surveyor's son. The subject then dropped.

In consequence of a recent outbreak of diphtheria at the cottage homes of the workhouse at Worcester, inquiries have been made, and the result was reported to the board of guardians at their fortnightly meeting on Friday. It was stated that, owing to the condition of the drains at the cottage homes, which are of recent construction, the sewage was finding its way into the soft-water tank, as there was no trap to the pipe taking the overflow from the tank to the sewer. It was further stated that sewage a yard in depth was discovered in the soft-water tank. It was decided to ask the architects, Messrs. H. Rowe and Son, to meet the cottage home committee at once.

At a meeting of the South Shields Town Council held on the 5th of January last, the borough engineer, Mr. Matthew Hall, tendered his resignation after having held the office for nearly thirty years. In consequence of Mr. Hall's long service, the town council unanimously agreed to appoint him as their consulting borough engineer for a term of seven years at a salary of £150 per annum. Mr. Hall will commence private practice in the town as soon as his successor is appointed and can take up the duties.

**MEETINGS FOR THE ENSUING WEEK.**

**SATURDAY (TO-MORROW).**—Edinburgh Architectural Association. Visit to the Prudential Assurance Buildings, Jenner's Buildings, and the Stock Exchange, St. Andrew's-square. 2 p.m.

**MONDAY.**—Clerk of Works' Association. Annual Dinner at the King's Hall, Holborn Restaurant. 6.30 p.m.

Society of Arts. "The Principles of Design in Form," Cantor Lecture No. 1, by Hugh Stannus. 8 p.m.

Bristol Society of Architects. "Some Ancient Roman Buildings." Gaston Green.

**TUESDAY.**—Society of Arts. "The Goldfields of Klondyke and British Columbia," by W. Hamilton Merritt. 4.30 p.m.

Institution of Civil Engineers. "Stability of Channels through Sandy Estuaries," by P. M. Crossthwaite. 8 p.m.

**WEDNESDAY.**—Society of Arts. "The Protection of Industrial Property," by J. F. Isebin, M.A., LL.M. 8 p.m.

Edinburgh Architectural Society. "Normandy," by J. E. Forbes. Dowell's Rooms. 8 p.m.

St. Paul's Ecclesiastical Society. "Some Cathedrals of Northern Spain," by Joseph Grimshire. 7.30 p.m.

**THURSDAY.**—Society of Arts. "The Plague in Bombay," by H. M. Birdwood, C.S.I. 4.30 p.m.

**FRIDAY.**—A.A. Lyric Club. Cinderella Dance. King's Hall, Holborn Restaurant. 7.30 p.m.

Birmingham Architectural Association. "Sena and Baldessare Peruzzi," by Francis W. Bedford. 6.45 p.m.

**CHIPS.**

The Public Hall, Northampton, is being ventilated by means of Shorland's patent exhaust roof ventilators and special inlet tubes, the same being supplied by Messrs. E. H. Shorland and Brother, of Manchester.

Kirkcaldy is to promote a Bill in the present session of Parliament for the construction of a new harbour and a line of railway to the new coalfields in the neighbourhood.

Mr. G. F. Bodley, A.R.A., has inspected the west front of Peterborough Cathedral, and his observations will be laid before the Restoration Committee at their next meeting.

The Bishop of Beverley unveiled and dedicated on Friday the fresco which has been put in the Altofts St. Mary Magdalen Church. A few months ago the church was renovated, and was also decorated. Mrs. Meynell Ingram, who built the church 20 years ago, has had the space for the chancel arch treated with a figure subject, at her expense, the subject chosen by her being the "Annunciation." Mr. Gustave Hiller, of Manchester, has designed and carried out the work. The reredos and the organ screen are also being decorated at the cost of Mrs. Ingram.

The county council of Argyll decided on Tuesday to erect a court-house adjoining the new police buildings at Dunoon. Mr. William Fraser, Dunoon, was appointed architect.

In giving judgment on Friday, in an action brought by Mrs. Mary Barnes, of 5, Orsett-terrace, Bayswater, against the trustees of the Scantlebury Estate, arising out of the drainage of her premises, Mr. Justice Wright said it was clear that the defendants employed as their agent a member of the Paddington Vestry, that the agent employed as his builder another member of the vestry, and that the work of the builder was inspected on behalf of the vestry by a son of the builder. He thought it was a reproach to the whole system of local government that such a state of things should exist.

Mr. Hayter, civil engineer, of London, sat at Manchester on Tuesday and Wednesday as arbitrator with regard to a claim for £15,000 made by the Manchester Racecourse Company against the Lancashire and Yorkshire Railway Company, being the estimated value of a piece of land on the racecourse belonging to the claimants, which is required by the railway company for the extension of their line to the Ship Canal docks. It was shown on behalf of the claimants that the alteration would block access to streets leading to the barrier wall of the racecourse. The claim was not only for the value of the land, but also for injuring the prospects of the racecourse company in view of the alterations. The arbitrator has reserved his award.

A vacancy has occurred in the surveyorship to the vestry of St. Martin-in-the-Fields owing to the present surveyor, Mr. Chas. Mason, A.M.I.C.E., having accepted a partnership in the old-established business of Messrs. Foster and Pearson, horticultural builders and heating engineers, of Beeston, Notts. Mr. Mason's resignation was accepted with much regret at the meeting of the vestry on the 3rd inst., he having held the appointment for the past eight years. The question of appointing a successor has been referred to the works committee for consideration.

**Trade News.**

**WAGES MOVEMENTS.**

**CARDIFF.**—The whole of the masons in the employ of two large firms of building contractors at Cardiff—viz., Messrs. Turner and Sons and Messrs. W. Thomas and Co.—are on strike against the practice of sub-contracting. A number of hands came out early last week, and on Saturday the remainder laid down their tools.

**LEEDS.**—For some time past the master builders of Yorkshire have had under their consideration the formation of a federation of employers engaged in all branches of the building trade, on similar lines to that which exists in Lancashire. While the arrangements for mutual protection are being carried out, the masters in Leeds are confronted by a batch of demands from their employes for increased wages and improved conditions of labour. The operative plumbers have tendered a six months' notice, which expires on June 1, for an increase in the rate of pay from 8d. to 9d. per hour, and for the alteration of the rules relating to the number of apprentices, work on out-jobs, and the hours of work in winter. The plasterers have asked for an additional penny per hour, and for several minor concessions. The Master Builders' Association offered the men an increase of a halfpenny; but as this was declined, the employers have now withdrawn the offer. The joiners have given notice, which will terminate on May 1, asking for an increase from 8½d. to 9d. per hour. The masons are also seeking a similar increase, and practically the only workmen in the building trade who have not asked for an advance are the bricklayers. A disposition exists on the part of some masters to give the labourers an advance, though it is not definitely known that the feeling is anything like unanimous.

**RUGBY.**—At the beginning of January the carpenters and joiners of Rugby made application to the master builders of the town to increase their wages from 7½d. to 8d. per hour, and also that overtime at the rate of time and a quarter should commence after ten hours' work instead of eleven, as hitherto. They further asked that on all buildings lock-up places for the safe keeping of tools should be provided. The masters have agreed to the first and last of the demands, but decline to accede to that relating to overtime, and the men have unanimously decided to accept the modified terms.

The town council of Edinburgh adopted on Tuesday a proposal to erect public baths, including Turkish baths, in Portobello. The resolution to put up the vacant site adjoining the new North Bridge, in one or more lots, at a total upset of not less than £230,000 was again confirmed, on this occasion by a majority of 25 votes to 12, and thus now becomes an Act of Council.

The Corporation of London have recently sanctioned a scheme for the extension of the Art Gallery at Guildhall, at an estimated expense of £1,600. The plan, which has been prepared by Mr. Andrew Murray, the City Architect, shows the absorption of the ground-floor offices of the Land Tax Commissioners and the Mayor's Court in Guildhall-yard. The newly-acquired space will consist of three rooms connected with each other, and lighted with separate skylights, a connection with the existing galleries being made. The total floor area of the additional rooms is about 1,700ft. superficial. It has, however, been decided that no steps shall be taken to carry the scheme into effect until equivalent accommodation at the existing rent has been provided, in or about Guildhall, for the tax commissioners, whom the proposal would displace.



**BILLS OF QUANTITIES, PLANS, &c.**  
Lithographed in best style and with great expedition by  
**PARTRIDGE & COOPER,**  
ARCHITECTS' AND SURVEYORS' LITHOGRAPHERS,  
191 & 192, Fleet St., and 1 & 2, Chancery Lane,  
London, E.C.  
Special Prices quoted for Large Jobs.  
LIBERAL DISCOUNTS ACCORDING TO ARRANGEMENT.

**IS THE ELECTRIC LIGHT REALLY DEARER THAN GAS?**  
A large number of replies to the above query from actual users will be sent post free on application to the  
**COUNTRY HOUSE SPECIALISTS,**  
**Messrs. DRAKE & GORHAM,**  
65, VICTORIA STREET, WESTMINSTER, LONDON, S.W.

**LATEST PRICES.**

IRON, &c.		Per ton.	Per ton.
Rolled-Iron Joists, Belgian	.....	£6 0 0	to £8 10 0
Rolled-Steel Joists, English	.....	6 10 0	" 7 10 0
Wrought-Iron Girder Plates	.....	5 15 0	" 6 10 0
Bar Iron, good Staffs	.....	7 0 0	" 8 0 0
Do., Lowmoor, Flat, Round, or Square	.....	17 0 0	" 17 0 0
Do., Welsh	.....	5 15 0	" 5 17 6
Boiler Plates, Iron—			
South Staffs	.....	7 17 6	" 8 5 0
Best Suedshill	.....	10 0 0	" 10 10 0
Angles 10s., Teea 20s. per ton extra.			
Builders' Hoop Iron, for bonding, &c., £3 15s. 0d. per ton			
Builders' Hoop Iron, galvanised, £15 10s. 0d. per ton			
Galvanised Corrugated Sheet Iron—			
No. 18 to 20.	.....	No. 22 to 24.	.....
6ft. to 8ft. long, inclusive gauge	.....	Per ton.	.....
Best ditto	.....	£10 15 0	to £11 0 0
		11 5 0	" 11 10 0
Cast-Iron Columns	.....	Per ton.	.....
Cast-Iron Stanchions	.....	£8 0 0	to £8 10 0
Cast-Iron Sash Weights	.....	6 0 0	" 8 10 0
Cast-Iron Socket Pipes—			
3in. diameter	.....	5 10 0	" 5 15 0
4in. to 6in.	.....	5 5 0	" 5 10 0
7in. to 24in. (all sizes)	.....	4 15 0	" 5 5 0
[Coated with composition, 2s. 6d. per ton extra; turned and bored joints, 5s. per ton extra.]			
Pig Iron—			
Cold Blast, Lilleshall	.....	Per ton.	.....
Hot Blast, ditto	.....	105s. to 110s.	.....
Wrought-Iron Tubes—Discount off Standard Lists f.o.b.		57s. 6d. to 62s. 6d.	.....
Gas-Tubes	.....	75p.c. Fittings 77p.c.	.....
Water-Tubes	.....	70	" 72
Steam-Tubes	.....	62½	" 65
Galvanised Gas-Tubes	.....	60	" 62½
Galvanised Water-Tubes	.....	55	" 57½
Galvanised Steam-Tubes	.....	45	" 47½
Sheet Zinc, for roofing and working up	.....	Per ton.	.....
Sheet Lead, 3lb. per sq. ft. super.	.....	£22 10 0	to £23 10 0
Pig Lead, in cwt. pigs	.....	14 15 0	" 15 15 0
Lead Shot, in 28lb. bags	.....	13 10 0	" 14 10 0
Copper Sheets, sheathing and rods	.....	17 19 0	" 18 10 0
Copper, British Cake and Ingots	.....	58 19 0	" 59 0 0
Tin, Straits	.....	51 10 0	" 52 10 0
Do., English Ingots	.....	63 5 0	" 64 5 0
Spelter, Silesian	.....	66 0 0	" 66 10 0
		17 7 6	" 18 7 6
Cut Clasp Nails, 3in. to 6in.	.....	Per ton.	.....
Cut Floor Brads	.....	£9 15 0	to £9 15 0
Wire Nails (Points de Paris)	.....	8 10 0	" 9 10 0
0 to 7 8 9 10 11 12 13 14 15 B.W.G.			
8/6 9/0 9/6 10/3 11/0 12/0 13/0 14/9 16/9			per cwt.

**TIMBER.**

Teak, Burmah	.....	per load	£14 0 0	to £15 10 0
" Bangkok	.....	"	10 10 0	" 15 0 0
Quebec pine, pitch	.....	"	2 10 0	" 4 10 0
" Oak	.....	"	4 15 0	" 6 0 0
" Birch	.....	"	4 2 1/2	" 6 0 0
" Elm	.....	"	4 0 0	" 5 0 0
" Ash	.....	"	3 5 0	" 4 10 0
Dantaic and Memel Oak	.....	"	2 2 6	" 3 2 6
Fir	.....	"	1 15 0	" 3 15 0
Wainscot, Riga p. log	.....	"	2 10 0	" 3 10 0
Lath, Dantaic, p.f.	.....	"	4 10 0	" 5 10 0
St. Petersburg	.....	"	5 0 0	" 6 10 0
Greenheart	.....	"	8 5 0	" 8 10 0
Box	.....	"	4 0 0	" 15 0 0
Sequoia, U.S.A. per cube foot	.....	"	0 1 8	" 0 1 10
Mahogany, Cuba, per super foot	.....	"	0 0 5	" 0 0 6
1in. thick	.....	"	0 0 4	" 0 0 5
" Honduras	.....	"	0 0 4	" 0 0 5
" Mexican	.....	"	0 0 4	" 0 0 5
Cedar, Cuba	.....	"	0 0 4	" 0 0 4
" Honduras	.....	"	0 0 3	" 0 0 4
Satinwood	.....	"	0 1 6	" 0 1 2
Walnut, Italian	.....	"	0 0 3	" 0 0 7
Deals, per St. Petersburg Standard, 12ft.—12ft. by 1 1/2in.				
Quebec, Pine, 1st	.....	£19 15 0	to £25 15 0	
" 2nd	.....	14 0 0	" 16 10 0	
" 3rd	.....	6 10 0	" 11 0 0	
Canada Spruce, 1st	.....	9 10 0	" 11 5 0	
" 2nd and 3rd	.....	8 0 0	" 9 0 0	
New Brunswick	.....	7 15 0	" 8 0 0	
Riga	.....	6 15 0	" 7 15 0	
St. Petersburg	.....	8 15 0	" 12 15 0	
Swedish	.....	9 0 0	" 15 10 0	
Finland	.....	7 10 0	" 8 0 0	
White Sea	.....	9 0 0	" 16 0 0	
Battens, all sorts	.....	5 0 0	" 30 0 0	
Flooring Boards, per square of 1in.—				
1st prepared	.....	£0 8 6	" £0 15 6	
2nd ditto	.....	0 7 0	" 0 12 0	
Other qualities	.....	0 5 0	" 0 6 6	
Staves, per standard M.—				
Quebec pipe	.....	£35 0 0	" £42 10 0	
U.S. ditto	.....	230 0 0	" 240 0 0	
Memel, cr. pipe	.....	200 0 0	" 210 0 0	
Memel, brack	.....	200 0 0	" 210 0 0	

**OILS.**

Linseed	.....	per ton.	£14 17 6	to £15 5 0
Rapeseed, English pale	.....	"	24 0 0	" 24 5 0
Do., brown	.....	"	32 10 0	" 33 0 0
Cottonseed, refined	.....	"	14 0 0	" 15 5 0
Olive, Spanish	.....	"	31 0 0	" 33 0 0
Seal, pale	.....	"	23 10 0	" 24 0 0
Cocoonut, Cochín	.....	"	26 0 0	" 27 0 0
Do., Caylon	.....	"	22 0 0	" 22 10 0
Palm, Lagos	.....	"	25 0 0	" 25 10 0
Oleine	.....	"	18 15 0	" 19 15 0
Lubricating U.S.	.....	per gal.	0 6 8	" 0 7 6
Petroleum, refined	.....	"	0 0 4	" 0 0 4
Tar, Stockholm	.....	per barrel	1 0 0	" 1 5 0
Do., Archangel	.....	"	0 13 6	" 0 15 0
Turpentine, American	.....	per ton	23 0 0	" 23 10 0

## THE BUILDING NEWS

AND ENGINEERING JOURNAL.

VOL. LXXIV.—No. 2250.

FRIDAY, FEBRUARY 18, 1898.

## NEGLECTED FEATURES.

"STRIVING to better, oft we mar what's well," is a truth lost sight of in a good deal of what is done in the name of improvement and architecture. Those who regulate our buildings and thoroughfares have widened and rebuilt at the sacrifice of health and comfort. Our straight and wider streets have been purchased at the cost of diminished area and light. Again, in our architecture we have copied almost every style under the sun, but have been remiss in attending to those essential matters which contribute to use or comfort. Our studies have been concerned with the general features, while we have overlooked the special ones which have given the *raison d'être* of much of the design. Let us take two or three features, and see how often we have missed what should have been fundamental! In the planning of our streets, especially at their junction, the desire is seldom to do more than cut the corner off if the streets converge at a rather sharp angle, or to form a curve where four or more meet—in short, to make a "circus." For the purpose of facilitating traffic, and of making a large and imposing area, we can wish nothing better; but architecturally it leaves much to be desired. It is easy to strike a circle at the meeting of several streets. It would not be so obvious, perhaps, to form a square or oblong space at their intersection, though the arrangement would give the opportunity for architectural effect. Take a junction of five or six thoroughfares in which they meet at different angles. Right angle and obtuse corners would be formed, and some variety of treatment might be expected. In the case of two equi-angular streets crossing at right angles, the square could be treated with better effect, as at each of the four corners there would be a square formed between the lines of the streets produced and the fronts of the building. This space could be laid out, turfed, and planted. Each corner building would then make an indent of two frontages, which would help planning, especially of corner entrances. On the other hand, very little effectiveness in elevation can be got out of an inverted curve. What have our Ludgate, Holborn, or Oxford Circuses to show in architectural treatment? They are atrociously commonplace and uninteresting. Where efforts are made to emphasise the angles, they are often vulgarised by ugly-looking roofs or mansards, and by huge advertising posters. Let us look at the cities of the United States. Take Washington. The plan or scheme of laying out was engraved in 1792, and is the nucleus of the present capital. The city was planned by Andrew Ellicott, C.E., after the plans of Major Pierre L'Enfant. The principles of arrangement are described thus:—"The grand avenues, and such streets as lead to public places are from 130ft. to 160ft. wide, and may be conveniently divided into footways, walks of trees, and carriage-way. The other streets are from 90ft. to 110ft. wide. In order to execute this plan Mr. Ellicott drew a true meridional line by celestial observation, which passes through the area intended for the Capitol; these lines he crossed by another one east and west, which passes through the same area. These lines are accurately measured and made the basis on which the whole plan was executed." According to this principle the streets are oriented on true meridians. Few cities have such noble streets on rectangles

some in diagonal directions. The streets absorb 43 per cent. of the whole area, and what is worth notice is that the plan of Washington shows square and oblong spaces at the chief centres, instead of circular. In Paris the effect of some of the recently formed boulevards, is to cut or to cross at acute and other angles the older streets, and to render it necessary to round off or cant the corners of the building where the intersections come. Take, for example, any of the newer thoroughfares formed under the late Empire, such as the boulevard Haussman, or the boulevard Malesherbes, which runs from the Madeleine in a north-easterly direction. They intersect many old and narrow streets, as do the Rue Lafayette and the boulevard Italiens. These thoroughfares, as far as possible, have been made to terminate at some important centre, like the Grand Opera House or the Madeleine. But the minor intersections have been left to take care of themselves. Architects have done their best occasionally to emphasise them by Mansard roofs or other features, and, owing to the uniformity of the house-fronts in elevation and style, the result is not so incoherent or jumbled as they are in many of our new streets.

Corners and re-entering angles have been more cleverly managed by our French and Belgian neighbours. They are adepts at angle towers and turrets. The angle turret of the old Hôtel de Ville, Bourges, and that of the Hôtel de la Tremoille, Paris, are good examples of corner treatments. The Chateau de Chambord is a noble Renaissance instance of a palace with corner towers, circular in plan, crowned by slate conical roofs of bold design, enriched by dormers and tall chimneys, which impart a picturesque skyline to the building. Angle pavilions and roofs are important features of this kind. Those at the angles of the Louvre are of dignified size and importance, with which our English imitations compare unfavourably. Compare, for instance, one of these pavilions with any similar work in London. Notice, for instance, the pavilion of the Place Louis Napoléon—its palatial dignity, projecting insular columns on each front, the massive and profusely-carved dormers which rise high on each front of the roof, the angles of the roof itself, and its ornamental lead cresting. There is no stint here. The details of leadwork are massive and handsome. Tall chimney-stacks in some cases flank the roof and rise to a considerable height, and are enriched by panels and sculptured ornament on the sides. In other of the angles of the Court of the Louvre, as in the re-entrant angles, we find circular turrets crowned by low, hemispherical cupolas barely rising above the attic. The Hotel de Ville is another notable building where the lofty roofed pavilions are made the most of. Besides one at each corner of this large block, two stand flanking the handsome centre which faces the Place in front; the angles of these are emphasised by octagonal turrets, which are terminated by pointed roofs of the same plan at the level of the main roofs of the pavilions. Of the recent palatial residences in Paris, the house of M. Gaillard in the Place Malesherbes, designed by M. Fevier, architect, gives one of the best examples of pavilion roofing; the end roofs are of a sharp pitch, and the two longer planes meet in a crested ridge, the front ends of corner pavilion being semi-octagonal, which form is carried through the roof, producing a picturesque skyline. The architect, M. Corroyers, has taken as a *motif* the Chateau de Blois. Comptoir d'Escompte, Paris, is an imposing termination to a street. Its façade is pierced by one large arched recess, and is crowned by a steep quadrangular roof and bell-turret in the apex; sculptured groups of figures adorn the angles

and make a monumental building of considerable effect.

Both in our civic and domestic buildings the entrance is often the meanest part of the composition. We cannot say why it is that the English architect has so neglected this feature. Has it something to do with the idiosyncrasies of the English people—their reserve, if not coldness of manner? It may have. We must attribute the smallness and insignificance of the doorway partly, perhaps chiefly, also to our climate. A large doorway makes a cold house. There is something exceedingly petty in many of the entrances of even our public buildings. Look at any of those which ought to dignify the façades of the Mansion House, the seat of civic hospitality, or the great official departments in Whitehall; compare them with those of similar buildings in France or Belgium, like those of the City Hall or the Palais de Justice, Brussels, or the Hotel de Ville, Paris, or any of the great town-halls at Bruges, or Antwerp, or take the ecclesiastical domestic buildings. Have we anything to match the doorways of St. Maclou, Rouen; of the Madeleine, of St. Augustin, to say nothing of the grand portals of Notre Dame, Amiens, Rheims, &c., or that of the chateaux, of which the Chateau Azay-le-Rideau affords one of the finest examples? It would fill a page to give a list of some of the most notable in regard to their size and architectural embellishment, to the sculptural accessories which are so prodigally lavished on them in France, or the beautiful and exquisite woodwork and bronze relief of the doors. The jambs and arch also are often enriched by the most beautiful carvings, and the door-posts are ornamental features. In our modern buildings we attempt nothing beyond a plain moulded jamb or door-frame. The transoms and arch is bereft of any ornament. We can mention a few instances of buildings of a public kind in which the doorways are very narrow, and the arches and tympana are left quite plain or filled with poor sculpture in bas-relief. Recessed entrances and vestibules are scarce, though in our climate they afford the most welcome shelter from the weather. The *porte cochère* so common in the larger buildings on the Continent is a feature that has not "taken hold," and what we see of it in our streets is confined to a cast-iron structure of atrocious design stuck on the front in the most perfunctory manner. The ordinary West-End entrance porch, with its columns carrying a kind of tester roof, such as we see hundreds of in Cromwell-road, Kensington Gore, and Grosvenor-place, is one of the worst features of the Classic Revival period; some have been made useful by erecting a conservatory on the top. Happily it is disappearing, and in the newer neighbourhoods the porch is no longer a half-portico stuck on to a flat wall, but is made to assimilate with the architecture of the front. Still, there is a want of dignified design in many of these; some of them are more adapted for back than front entrances, and few show any desire to put the best design in this conspicuous and much-examined position, so as to ameliorate the condition of London street life.

## THE DUDLEY GALLERY ART SOCIETY EXHIBITION.

THE Dudley Gallery Art Society opens with a show of water-colours of unequal merit. Of course we have a large sprinkling of commonplace and of the pot-boiling class. The President (Walter Severn) sends several works marked by his usual style and care. We have surely seen "Caligula's Arch, Anglesey," before—a wonderful conformation of natural pipeclay rock, which closely resembles a flat arch, with abutments of stone on either side. Mr.

Severn is a good delineator of rock. The jutting escarpment of white cliff is well painted; in his equally effective "Corrie Halloch (the 'Awful' Glen), Ross-shire" (175), the granite fissure, or gorge, narrow and perpendicular, and awful-looking in its depth and gloom, is interesting. It is the deepest gorge in this part of Scotland. More mannered and tame is "Inverary and Gateshead" (100). A pleasing view of the "Norfolk Broads" in winter (196), under a sunny sky, with grey clouds and reflection on the rippled water, is another contribution. Landscape studies are very numerous. In the hands of such painters as L. Burleigh Bruhl, we expect soft atmospheric effects like the "Golden Hush of Eventide" (8), where the tones are subtly blended, and the dark outlines of the landscape appear against a waning light, and his river-scapes, "On the Wye" (38), and "On the Yare" (262). B'renger Bengel also sends one or two sunlight effects. His landscape (11) "An August Afternoon" is just the clear sunny effect one sees; a meadow with poppies, the distant village peering over the bright pasture. His "Tintern Abbey" is spoilt by the uncertain drawing of the ruins. Evangeline Jex-Blake, whose delightful sketches are always welcome, is charmingly truthful and delicate in her "Evening on the Palace Moat, Wells" (16); her old houses at "Lannion, Brittany" (28), and other sketches in Brittany, &c. Hubert Medlycott sends many drawings of Continental interest. His view of Antwerp Cathedral from Rue de Chevalier, "In Dieppe Harbour" (130), "Calais" (141), and a sketch of Amiens (268), show the present bias of this prolific painter of picturesque subjects. Reginald Jones's "Sunset Glow" (23) is broad and pleasing, and his "Grey Evening, Poole" (35), is distinguished also by breadth of colour, the mass of dark trees against sky and the grey tone are pleasing. Walter Bayes's "By the Sea" is a clever study in strong sunlight; a girl reclines on a portable chair on the sandy beach; a crested wave is seen advancing; but it is the sunlight effect that we admire. His "Le Quai aux Fleurs" (45) is a brilliant piece of flower painting. Miss Maud Turner's very nice study of a little girl, "Peeling Apples" (31), is good in drawing and colour, and pleasant colour is seen in Fred. Jas. Aldridge's "A Strong Breeze" (39). We must pay a tribute again to the skilful drawing, accurate and delicate, of Chev. S. Giampietri, who sends half a dozen subjects of architectural interest, "Stylobate of the Temple of Antoninus, &c., Forum, Rome" (42), is a delightful piece of perspective drawing and charming colour; the bases of the columns on the massive podium, which only we see, are painted with subtle skill, the roughness, chipped base mouldings, and texture of the stone are all here, with all the charm of colour. "In the Campagna" (34), the ruins of the Forum and its delicate bas-reliefs (78), a "Pelagic Altar, Bellegra" (99), the "Peristyle of the Temple of Faustina" (190), and a sketch of rock (275) are other works by this consummate painter of Roman remains. Lexden L. Pocock's imposing "Forest Glade" (51), a hollow beech trunk and the flickering sunlight through the foliage, is very careful and dexterous, though the particular tint of green is open to question. Mrs. Mariquita J. Moberly, in her "Little Woodwinder" (58), has given a nice head, and the colour is pleasing. J. Maud Peel, in "The Lost Lambs" (67), shows her favourite theme; there is sweetness in the colour and harmony. We also notice some delicate harmony and colour in her "Fishing Boats" (87). Another lady painter of promise is Rose Douglas; her "Water Meadow" (83) is very fresh. No. 68, "On the Qui Vive," by Walter Bothams, is also of merit. Tameness

of handling is often associated with careful drawing, as in Nos. 75, 80, and 82. In 106, "In the Garden," E. S. Standen also mistakes minuteness of finish for inspiration and true sentiment. It is a pity lady painters (85) devote their talents to such trivial subjects as "afternoon teas" and other like *genre*. E. Duassut's "Hush of Evening" (86) is careful. Lexden L. Pocock sends several pleasing subjects: "Great Expectations" (90) is one of them. Miss Agnes J. Rudd (107) is broad and truthful in colour in her "Evening, Walberswick," and Miss Maude Turner's "Waiting" (104) is gracefully drawn. Miss Margaret Bernard is indomitable; she sends half a dozen sketches. Nos. 115 and 122, sketches on Bournemouth Sands and on the Thames, are sharp and bright, and her dexterous touches and high lights tell; but her view of "Houses of Parliament" is weak in proportion and drawing. Harriet Skidmore in the "Breakers" is also promising. Another lady artist, Mrs. E. Heathcote, sends a nice study of a girl's head in profile, the tone being taken from the rich auburn hair. No. 139, "On the Moors," "Fishing Boats, Etaples," by Rose Douglas; an admirable drawing by David Green, "Wintry Weather," fisherfolk watching a rough sea breaking over wall of quay (144); R. Wane's fresh blue sea (158), and Miss Rudd's slight but effective sketch of Dunwich (157); S. G. W. Roscoe's "A Peep of the Dart" (152) (very mannered), a fault which we notice in Sir W. Eden's woodland (162), No. 177, are other subjects. Rich colour and clever treatment are to be seen in Albert Stevens's "On the Moors, Bettws-y-Coed" (179), and the drawings of J. Carlisle of Kingsworthy and Avington, and N. Benett of Christchurch, Hants, and of Frances E. Nesbitt of "Harbour, Whitby" (211), and a few on the screen may be mentioned. Quite one-half the pictures might be spared with advantage.

#### A COAT OF PAINT.—II.

IN the last article it was shown how the several coats of paint are composed and used on painting a good quality job in painting wood. In this article are considered the physical and chemical changes that occur in the paint compound that has been spread on the wood. It will be noticed that the ingredients which have been used are linseed-oil (raw and boiled), pigment, white and red leads, turpentine, driers (a complex compound), and knotting (also a complex compound).

Let us now consider the physical and chemical nature of these bodies. The linseed-oil, when in combination with red-lead, unites therewith to form a very hard quick-drying paint, because this oxide of lead unites with the fatty acids of the oil, and also imbibes the glycerine base of the oil, and by this means the compound becomes a hard, quick-drying one.

In the case of the white-lead, a similar action does not occur. What does take place is this:—The linseed-oil becomes split up into its constituents—fatty acids and glycerine—and the white-lead (which is a mixture of hydrate and carbonate of lead) unites with these bodies only to a small extent, except in the case of the linoleic acid that is separated from the linseed-oil. These two bodies (white-lead and linoleic acid) unite to form linoleate of lead, a substance that is soluble in water. Meanwhile, the other constituents of the linseed-oil are more or less in a free state—the glycerine particularly so, as it will not combine with any of the bodies present. As a consequence, it is only the compound of linoleate of lead that dries to hardness; but the hardening of this body is retarded by the presence of the glycerine, which will imbibe moisture from wherever it can obtain it.

In the case of boiled linseed-oil that has been converted into a kind of varnish which will dry up into a tough, elastic mass. Turpentine is a volatile fluid chiefly, but it leaves a small residuum of resin behind after the volatile portion has flown away. The driers consist of a mixture of litharge and other lead salts with linseed oil, and in some cases of borate or sulphate of

manganese, or of zinc with zinc oxide and linseed oil. These compounds assist the drying quality of the paint with which they are mixed, because they either supply the linseed oil with oxygen from itself, whereby it is enabled to become converted into a hard, tough, elastic skin; or else the drier acts catalytically—that is, it absorbs oxygen from the air at a quicker rate than what linseed oil does; and as it does so, a portion of the imbibed oxygen is conveyed direct to the linseed oil. (It should be explained that the "drying" of linseed oil simply consists in its fatty fluids—chiefly the linoleic acid—being oxidised.)

The composition of "knotting" was explained in last article.

Now, all the above reactions are legitimate ones—such as should always occur in the paint compound during its conversion from a soft, semi-fluid state to a hard, tough, impermeable skin or coat of paint. There are, however, many factors—atmospheric and chemical—which interfere with these legitimate reactions occurring, and it is this interference that causes a coat of paint to exhibit the vagaries of peeling, blistering, chipping, crumbling, &c., subjects which we will now consider. In the first or primary coat, the presence of the red-lead causes the thin coat laid on to dry very quickly, and practically form a thin layer of a hard cement-like body on the surface of the wood—one which will not allow the wood to absorb oil from the coats subsequently put on. If the primary coat consisted of all red-lead and oil, an impenetrable buffer would be found between the absorbent fibres of the wood and the remaining coats of paint put on; but the amount of red-lead is so small, and the amount of white-lead so large, that this impermeable coating is not sufficiently thick enough, as the white-lead allows a large proportion of soluble linoleate of lead to be formed, and it is this linoleate which allows future mischief to occur in the paint.

In all the subsequent coats there is this soluble linoleate of lead, together with glycerine which is eliminated from the oil. Now, as the coat of paint dries first on its exterior surface by reason of that portion being immediately in contact with atmospheric oxygen, the soft mass of lead linoleate has a difficulty in hardening, and the glycerine has no means of escape through the exterior surface of the paint. As the drying and hardening of the paint deepens, this glycerine is driven further and further into the interior surface, and, as we have seen the primary coat is not impermeable, the glycerine is brought into immediate contact with the wood, which, being of a porous nature, imbibes the glycerine.

Now the production of blisters is on this wise:—When the glycerine is driven to close proximity to the wood itself, the latter material, being porous, will absorb it, and as glycerine will mix with water in any proportion, any moisture that has not dried out of the fibre of the wood will unite with the glycerine. Now when the wood is subjected to alternations of temperature, particularly the sun's heat, then water will be gathered up into patches beneath the still soft paint and form the origin of the future blister; this is easily proved by pricking one of these newly-formed blisters which the paint covers. If it is soft, an aqueous fluid will exude, which, if tasted, will be sweetish to the taste (glycerine is a very sweet fluid). Now, as there is no escape for this watery fluid through the paint, its only source of escape is through the wood, which will absorb it as soon as the wood contracts with a colder temperature. As a consequence of this absorption, paint which has been bulged up by the watery fluid will not regain its former level, but remain bulged up, covering a void space. If you chip off the paint forming a dry blister you will see the plain wood beneath, or, at most, the priming coat, through which the watery fluid has been absorbed (owing to the presence in the priming coat of the soluble linoleate of lead). Now, if the wood has been subjected to the fierce rays of the sun, the paint forming these blisters will harden and dry at a quicker rate than the paint which still adheres to the wood, and, as a consequence, they become dry and brittle before the other coats of the paint have completely hardened, but still remain elastic. As a consequence, the slightest friction, rubbing, or vibration of the woodwork will cause these brittle patches of paint to fall off, and expose the wood beneath.

If the wood is a hard non-porous one, or if the primary coat has dried so hard as to prevent the



glycerine that has been eliminated from the subsequent coats of paint penetrating to the wood, the glycerine will be gathered up underneath the paint in a great number of small blisters, and these, if pricked while soft, will allow a sweet liquid to exude, which is the glycerine without the presence of water, but contaminated with other fluids that have been evolved during the decomposition of the linseed oil during the drying of the paint. These innumerable small blisters, when dry and brittle, will give the appearance to the paint of being pock-marked when they are rubbed off. It is only when the glycerine can absorb water from the wood fibre that large or big blisters result. The remedy for preventing the formation of blisters is to allow each coat to become more than half-dried before laying on the next coat; but the best remedy of all is to dispense with the use of driers in the paint and use a varnish vehicle instead, or else have the pigment ground up in an oleo-resinous one, such as was mentioned in the article on "The Vagaries of Paint."

#### THE PEELING OF PAINT

is caused by the non-adherence of the second and subsequent coats to the wood or the primary coat. This non-adherence is caused by the inability of the material on which the paint is spread to amalgamate or partially unite with the paint, and it is also sometimes caused by a too-quick drying of the coats of paint, whence the paint skin is not sufficiently elastic to retain its adherence, but, by drying up too rapidly becomes brittle, and then peels off the wood.

#### CRACKS IN PAINT

are caused by several influences. Thus, if the paint is exposed to a direct heat in one or two particular spots, leaving the remaining portion of the painted surface exposed to the normal temperature, the paint which is under the influence of the greater heat will dry at a greater rate than the other portions, and, as a consequence, contract or be drawn away from the slower-drying paints, and then fissures, long or irregular cracks, will be caused in the paint, leaving the primary coat on the wood itself exposed to view. The remedy for this defect is to allow the painted surface to dry at a uniform rate. This, of course, cannot always be effected, as, for instance, where there is a direct draught from a door, window, or other opening on to the wet paint; but a great deal may be effected as a remedial agent in employing a quick-drying varnish-paint, which, by its uniform rate of drying, will not allow the paint to contract or expand. Of course, such a paint should be shaded from the direct influence of the sun's rays.

Pitting in paint is often caused by the presence of water in the paint. This water is often introduced into the paint-pot by not having properly freed the brushes from the water in which they have been kept while not in use. It would be much better to keep paint-brushes in turpentine when not in use. Another cause of the presence of water is due to the paint having been spread during moist or damp weather, or on a damp surface.

One frequent cause of a paint coating, peeling or pitting is the fact of its being spread on green wood—i.e., wood from which the sap has not been completely dried out. This sap is more or less acid, and as it dries out of the wood by rising to the surface, it prevents the paint adhering, and so causes one or the other of the above phenomena.

So far we have not yet touched on the employment of adulterated materials, but have considered that the best and purest materials procurable have been used on the job. When, however, the materials have been adulterated, or substitutes for linseed-oil or turpentine have been used, "confusion worse confounded" reigns supreme as regards the "deviltries" that may occur in a coat of paint. One example will suffice. If, as is frequently the case, benzine, or some other quickly-evaporating fluid, has been used as a vehicle in which to grind or mix the pigment, such volatile fluid will evaporate and leave the solid particles of pigment in a powder or non-adherent pulverulent mass. In other respects, such a fluid will leave the paint dull and bereft of brilliance.

The chemical and physical changes to which a paint is subject by the immixture of spurious materials are too numerous to be further mentioned here. They are, in fact, important enough to demand an article to themselves.

There is one particular body the influence of which has not been discussed in this article, and that is the legitimate and abusive use of "driers." These compounds are very inimical in a paint; but the vagaries their presence engenders are too varied to be now discussed, and can be more suitably treated in the article dealing with substitutes, adulterations, &c., used in paints, vehicles, and pigments.

H. C. STANDAGE.

#### SEWAGE PURIFICATION: THE SALFORD EXPERIMENTS.

MR. H. GILBERT WHYATT, A.M.I.C.E., deputy borough surveyor for Salford, read a paper entitled "The Present Position of the Sewage Purification Problem," at a meeting of the Sanitary Inspectors' Association (Lancashire and Cheshire Branch) held at the Royal Technical Institute, Salford, on Saturday afternoon, the 12th inst. Mr. J. T. Shawcross presided, and there was a large attendance. At the outset of his paper Mr. Whyatt remarked that it would be possible to describe in two words the present position of the problem; he proposed, however, to take a comprehensive view of the situation. The first inquiry by the Local Government Board was undertaken over forty years ago, a second was commenced in 1865, and a third in 1868. The third inquiry was the most important, as it was directed to the rivers of typical manufacturing districts in England and Scotland. In their third report the Commissioners said they considered that the right way to dispose of town sewage was to apply it continuously to the land, as it was only by such application that the pollution of rivers could be avoided. Referring in detail to the first report of the 1868 Commission, which dealt specially with the Mersey and Ribble basins, Mr. Whyatt spoke of the importance then attached to the manurial value of sewage sludge. Eventually this idea of manurial value was dropped, and experimenters would have been content with a chemical treatment which would meet the remaining difficulties; but their efforts were futile, and now only "patentees" had any hope of success. The "international" and "electrical" systems were brought forward, and the former had been successfully adopted in many places. The "electrical" was very successful also, but its expense was great. Mr. Whyatt dealt at considerable length with the process of treating sewage by biological agency, which, he said, dated no further back than 1882 or 1884, and about which the report of Mr. W. J. Dibdin (late chemist to the London County Council) and Drs. Sorby and Dupre clearly established the position that the foul matters in sewage were ultimately destroyed by the action of living organisms—the process being biological, and not chemical; and it was when these organisms were not allowed full scope to exercise their beneficent life-action that putrefaction resulted. Scott Moncrieff, Lowcock, and others had conducted experiments on these lines. In Salford, experiments had been going on for about ten years, and much time had been spent on various patented processes, chiefly chemical. About five years ago the committee turned their attention to artificial filters. The first set of six filters were arranged at three heights with a ventilation floor between each 20in. of filtering material. Two filters were composed of gravel and sand, two of coke breeze, and two of cinders, and very good results were at once obtained from them all. Cinders proved the best filtering medium. The experiment was continued for 15 months at an average rate of 500 gallons per square yard per day, with very successful results. It was then wished to prove the advantage of a preliminary "roughing" filter and varying degrees of aeration; and this experiment was still going on. The filters were tried at varying rates of flow, and so long as a filter did not choke up the effluent was uniformly good. If the filter choked up it was found that by leaving it idle for a week or two it would recover itself, and again take the sewage perfectly. In 1895 two filters 8ft. deep were made, in order to ascertain whether a deeper mass of filtering material would deal with a larger quantity of effluent, and it was found that while a 5ft. filter would deal with 500 gallons per yard daily, an 8ft. one would deal with 800 gallons. In 1896 the filters were run practically continuously for 12 months at the rate of 1,000 gallons per square yard per day, then for a short time at 500 gallons, and now at 700 gallons, the only rest being for a short

time daily, whilst the small pump supplying them was cleaned. Contrary to expectation, they stood that severe test. In place of the sprinkling troughs, spray jets were now used. The surface of the filter was perfectly open and water was not allowed to collect anywhere. There had been no appreciable growth of the brown sewage fungus since 1895, and the bacterial filters had been protected by a "roughing" filter of fine gravel. Some 25 precipitation experiments had been tried, and the effluent of all passed through the bacterial filters with good results. The Corporation had resolved to spend £80,000 in altering the works and laying down bacterial filters; but the Local Government Board had refused its sanction unless the corporation included a sum to cover the purchase of land over which the filtered effluent might be turned and further purified. Mr. Whyatt considered the time had come when the Local Government Board should be roused from its state of "agnostic immobility" and take upon itself to examine whether there was the efficiency in bacterial filters that was claimed for them. Mr. Whyatt was accorded a vote of thanks at the conclusion of the proceedings.

#### EXAMPLES OF GREEK AND POMPEIIAN DECORATIVE WORK.\*

A COLLECTION of measured drawings of Greek and Pompeian work is sure to find a welcome by all who value the subtle and the refined. The author, Mr. James Cromar Watt, visited the neighbourhood of Athens, Palermo, and Naples some years ago, and these drawings appear as the result of his study. The plates, which number 60, form a large folio volume, and the designs, mouldings, and ornaments have been drawn chiefly to a full size and photographed the same size as the drawings, by which means accuracy of detail has been insured. For the same reason shading has been omitted in many instances. The letterpress is limited to occasional notes in the list of plates; but these are in some cases quite inadequate. Many of the details are extremely delicate and beautiful. The first plate, for example, gives us details of the pedestal of white marble of the Niké of Pæonios, Olympia, erected about 420 B.C. The cornice and base of the triangular shaft are refined and simple in contour; the figure which surmounted the pedestal is from Grütner's restoration. The sections of cornices and base are given to a full size. The white marble cornice from the National Museum, Athens, showing a bold cima-reversa, with leaf enrichment and honeysuckle at the corners, is a fine profile. The incised and moulded ornament from the Acropolis, in white marble with traces of painting in Plate 4, is wanting in the colour; the position and height are not stated, without which the colour of the ornament is greatly lost, and the same criticism applies to other examples in the volume, as in the full-size painted ornaments from cornices in terracotta, Olympia (Plates 12, 13, 14), very beautiful developments of painted enrichments. The ornament is made up of the Greek zigzag, scrolls and frets, the darker parts being in one case purplish black, the lighter olive green on pale buff. One honeysuckle enrichment is buff-coloured on black ground. The cyma, in painted terracotta, from the Leonidæon, Olympia, is a fine example. Very graceful and delicate is the white marble ornament (honeysuckle) from the Erechtheion, Athens, plates 6 and 7, probably friezes. The terracotta antefixe from Athens (plate 17) and the examples of steles (plates 19-22) are fine. Among other instances we may mention the beautiful capitals in marble from the Propylæa, Eleusis, from the National Museum, Athens, from Olympia, Palermo, and Pompeii. Some of these are Ionic, and of good outlines; one is a simple volute from Olympia (plates 28, 30), and some more elaborate in sandstone covered with stucco. The Pompeiian capitals in grey marble, shown in plate 36, are very elegant adaptations of later Greek or Roman character, a Roman variation of the Doric type. The author gives several very beautiful drawings of bronzes, candelabra, from the Museo Nazionale, Naples: stands, vases, and lamps, which will be found full of suggestion for designers in metal-work. These are admirably and feelingly drawn, and are reproduced from the pencil drawings.

\* Examples of Greek and Pompeiian Decorative Work. By JAMES CROMAR WATT. London: B. T. Batsford.

ELECTRIC LIGHTING NOTES FOR ARCHITECTS.—XVII.

By AN ASSOC. INST. ELECT. ENGS.  
CONTROLLING DEVICES.

WHICHEVER system of wiring be adopted in an electric-light installation, it is essential that means should exist for controlling every circuit and appliance (lamps, motors, &c.) receiving electricity. The consumer requires, for instance, means for turning on or off any, or all his lamps whenever he may desire. The insurance companies also demand that means should exist for instantly breaking the circuit should an abnormal current traverse any circuit, or undue heat be produced. For the former, switches are used, and these, of course, are worked by hand; for breaking the circuit, if undue heating is produced, automatic devices are necessary, and these are known as *cut-outs*, which may be electro-magnetic appliances, or simply fusible cut-outs.

*Switches.*—A switch is a device introduced into an electric circuit for closing (making contact) or opening (breaking contact) the circuit readily and quickly. They are sometimes also used for diverting the current from one conductor to others. Since there are many ways in which a circuit may be made or broken, it is evident that there will be a large variety of switches in the

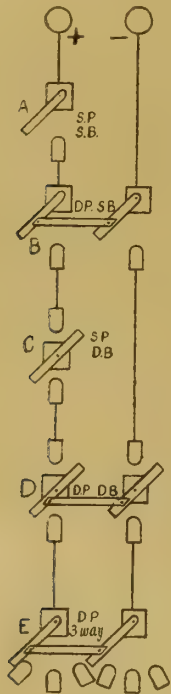

FIG. 48.

market, and all that will be done in these notes will be to explain some of the principles employed, to point out the good and bad points of switches, and also to point out how they should be used. A glance at the catalogues and price lists of the numerous makers will give some idea of the types in common use. In all cases, a switch consists of one or more movable contact pieces, two or more connecting terminals, an insulating handle and base, and the necessary connecting screws. In some cases carbon and sparking plates, covers, adjusting screws and keys are added.

To make and break contact, motion may be given to a pivoted or hinged contact bar, or by inserting or removing a plug. And since switches are used to control the main branches, the sub-main branches, lamp branches, and the lamps, they may be designated main, submain, branch, and lamp switches. It is also usual to denote the size according to the current they are designed to carry: thus there are 5, 10, 20, 25, 50, 75, and 100 ampere switches; and, as we shall presently see, it is essential that the dimensions of the various parts should correspond to the current they have to carry. Before explaining the various principles employed, it will be well to point out the special requirements of a good switch. When we remember that the introduction of switches and fuses introduce leakage

points, and bring down the value of the insulation of the circuit, it is evident that it is an important matter to use none but the best switches.

*Essential Qualities of a Good Switch:—*

(1) It should be of ample size, so that no overheating can take place at the point of contact or

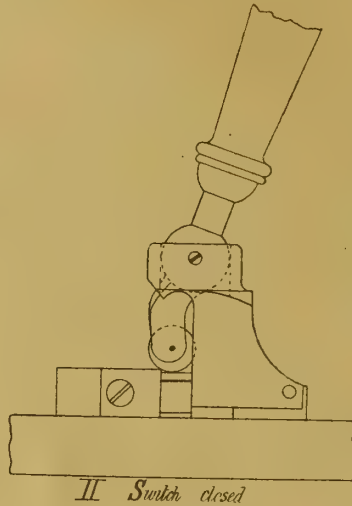
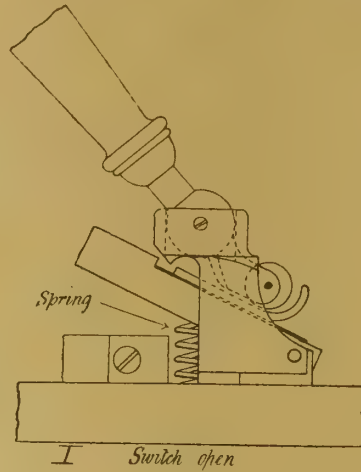

FIG. 49.

elsewhere. It should not carry more than 500 amperes to the square inch at any part.

(2) It should be solid, and have large contact surfaces. The contact surfaces should have twice the cross-sectional area of any other part, and the contacts should be intimate and adjustable.

(3) Contact surfaces should not deteriorate quickly, and they should be kept clean; rubbing surfaces under pressure clean themselves.

(4) There should not be too many parts or contacts, and they should be smooth-working.

(5) The *make* and *break* should be long, and be made easily and quickly, and when motion has

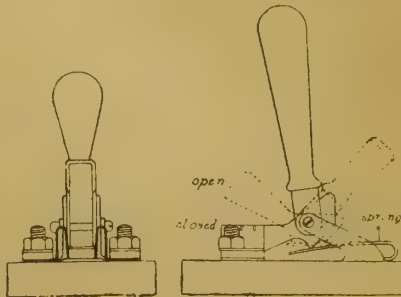

FIG. 50.

been given to the moving parts, they should not be able to take up an intermediate position between *on* and *off*, nor to take up a position so that a permanent arc can be formed. The permanent gap at *off* should be of sufficient length to prevent arcing.

(6) The current should not pass through the pin, pivot, or axle on which the moving arm works.

(7) The base and handle should be of good insulating and incombustible material. They should not readily condense moisture, nor facilitate the accumulation of dirt and dust.

(8) They should be protected from dirt and dust, and the cover should also be of incombustible material, and should preferably be either made or lined with non-conducting material. The covers of all switches should be kept clear of all the internal mechanism.

In connection with the requirements of a good switch, we may add the following rule, taken from the Institution of Electrical Engineers' wiring rules:—In order to ascertain that switches comply with the above requirements, samples should be selected from each pattern and size used, and should be tested at an E.M.F. and current 50 per cent. in excess of that which will be used on the circuits for which they are intended."

The method of using switches will be evident from Fig. 48, which is diagrammatic.

All kinds of switches are divided into two broad classes, the *single-pole* (S.P.) and *double-pole* (D.P.), and each of these are sub-divided into *single-break* (S.B.) and *double-break* (D.B.) switches. There are also *two, three, or more way* switches called *multiply-way* switches. Each of these kinds are shown diagrammatically in Fig. 48. At A, for instance, there is a *single-pole, single-break* (S.P., S.B.) switch; at B a *double-pole, single-break* (D.P., S.B.) switch; at C a *single-pole, double-break* (S.P., D.B.) switch; at D a *double-pole, double-break* (D.P., D.B.)

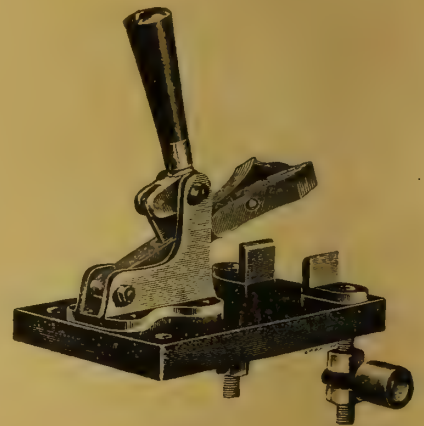

FIG. 51.

switch; whilst at E there is a *double-pole, multiply-way* switch.

The function of a single-pole switch is to open or close one, and only one, lead; but, as in incandescent lighting, the parallel system of distribution is universally adopted, and the lamps connected in parallel single-pole switches are seldom used, except as lamp switches. In no case is it advisable to control a circuit supplying current for more than four lamps by means of single-pole switches, as it is much more satisfactory to break both mains at once. In all cases where the supply is taken from the company's mains double-pole switches should be used, as they cut both the mains completely off when the lights are not required. A single-pole switch, of course, breaks the circuit and cuts off the light; but the whole of the house wiring is in connection with the mains, and the insulation is consequently subjected to the same strain as when the current is on. A double-pole switch, on the other hand, completely cuts off the house mains from the supply mains, and thus prevents any possibility of mishap occurring. To be satisfactory, double-pole switches should have the opposite ends of the moving bar thoroughly insulated from one another, and the two ends should break contact at the same instant, so as to prevent arcing. As is well known, sparking takes place whenever a circuit is broken; especially is this so when the circuit contains some electromagnet appliance, in which case the spark is very intense, and if the length of the gap between the contact surfaces is too small, there is some possibility of an arc being formed; and as the temperature of an electric arc is very high, the metal is fused and the surfaces are damaged, in addition to which there is some

possibility of fire resulting should any inflammable material be near. To prevent this excessive sparking, double-break switches are recommended, by which means a main is broken in two places at once, and the sparking subdivided.

Good contacts require pressure, and in many cases springs are used for this purpose, and to give the motion of the lever or the bar a quick action. Figs. 49, 50, and 51 will give some idea of the principles involved in the construction of switches so as to produce a good rubbing surface and a quick snap action.

Figs. 52 and 53 illustrate multiple-way switches, the former of which is a simple two-way switch.

The ring or claw pattern, represented in Fig. 54, is a very effective switch. From the figure

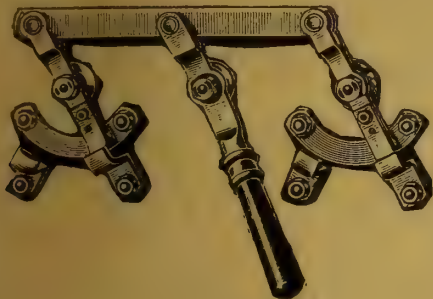

Fig. 52.

it will be noticed that the movable contact-bar passes between a slit in a piece of stout brass strip bent so as to form almost a circle. The ring is provided with a bolt passing right through the ring, by which means the grip may be adjusted so as to compensate for wear. The stiff working of the switch produces a kind of snap action, because there is a sudden release when the movable bar passes out of the ring. By snap action is meant that rapid movement or quick action which takes place when the spring is able to exert its power after the contact bar has moved through a certain distance. It is very essential that switches carrying large currents should possess this action, as it reduces the effects of sparking to a minimum.

In Fig. 54, II, the sweating socket, or thimble into which the conductor is soldered, is shown, and for large conductors this is the only satisfactory method of connecting the cable to the switch. For small lamps or branch switches the wires are often fastened by means of set-screws.

For the interior conduit and concentric systems

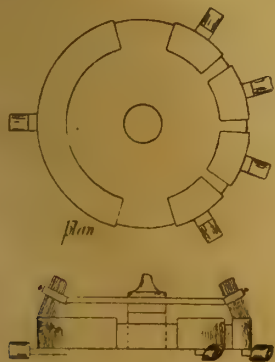

Fig. 53.

of wiring special switches are required, and as they are generally of the box form, they are known as box-switches. In the case of the concentric wiring, double-pole switches are dispensed with, since the second conductor is permanently earthed; consequently the switches used in this system are single-pole switches, and they are always connected to the inner conductor. They are, moreover, surrounded and insulated from a metal box, electrically and mechanically connected with the outside sheath of the conductor.

A form of switch not previously referred to is the wall plug. It differs from ordinary switches in that the movable part is completely removed from the base when the light is not required. Contact is made by two projecting pieces which fit into tapered recesses. They are used in connection with reading and other portable lamps.

Main switches should be placed close to the

generators if the supply is generated within the building, or at the transformer if transformed within the building, or at the point of entrance of the conductors into any building supplied from an external source.

When all the three wires of a three-wire system are brought into a house, the member of

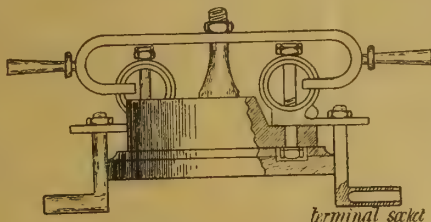

Fig. 54.

the switch connected to the middle wire must not make contact later or break contact sooner than the other two members; preferably the middle member should make contact sooner and break contact later than the other two members. Single-pole switches should not be on the middle wire of a three-wire system. In a five-wire system the same principles will apply.

**Fuses and Cut-Outs.**—The term "cut-out" is generally reserved for an appliance which automatically cuts out or breaks the circuit with a given excess of current, and a number of such devices depending upon electro-magnetic action are on the market, and may be relied upon to answer readily and quickly. They are, however, more particularly adapted for switchboard and

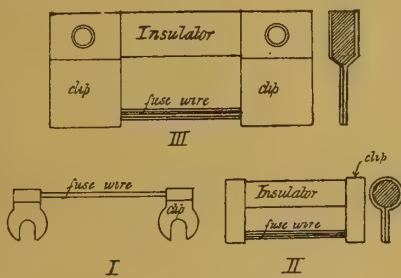

Fig. 55.

generating station work generally than for house fittings, in which case fusible cut-outs are used. A fusible cut-out, or simply a fuse, is a safety device, consisting of a short length of wire or strip of metal introduced into electric lighting circuits by being placed in series with a conductor to guard against the production of a dangerous excess of heat in any of the conductors, due to an abnormal increase of current. They should, therefore, be of such material and dimensions (length and sectional area) as to fuse, and thus break the circuit when the current increases by a given percentage. Their function is to prevent undue or dangerous heating of the leads, or the destruction of apparatus (lamps, &c.)

When we remember that every conductor has some resistance, and that this resistance which is offered to the passage of electricity manifests itself as heat, and that the heat produced is

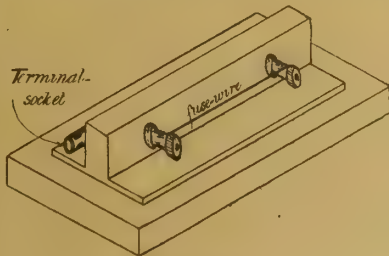

Fig. 56.

proportional to the square of the current, it is clear that the conversion of electrical energy into heat energy takes place very rapidly, and that an increase in current strength means a large increase of temperature.

Under ordinary circumstances, the sizes of the conductors are such as will prevent undue and

dangerous heating; but as short circuiting may result (if a fault or an earth is set up), and irregular driving or racing of the engine may take place, there is some possibility of an abnormal current passing along a circuit; in which cases danger exists, and it is an advantage when means exist for automatically severing the circuit. This is what fuses are intended to do.

The requirements of a good fuse are:—

(1) It must be reliable and easy to replace. Figs. 55, II. and III. show very satisfactory fuses possessing an insulating bridge for readily inserting the fuses when one has blown. Reliability is, of course, the essential quality of a good fuse. The material should be cheap, have a low melting point, not fuse explosively, nor be liable to undergo oxidation or molecular change with

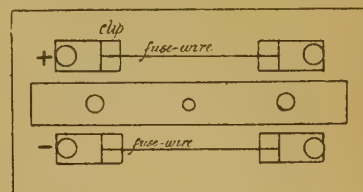

Fig. 57.

heating or lapse of time. The following particulars respecting some of the chief metals recommended will be useful.

**Platinum** has a high melting point (3,632° F.), is very costly, but is not affected by heating or time. Mr. Preece recommends this metal, but it is not advisable to risk such high temperatures before the wire melts.

**Copper** melts at 2,100° F., fuses explosively, and is liable to change its melting point after repeated heating, and it is not cheap.

**Iron** melts at 2,000° F., and although cheap, it very readily oxidises.

**Lead** has a low melting point (608° F.), is cheap, but very oxidisable.

**Tin** melts at 446° F., does not readily oxidise, and is cheap.

(2) It should enable perfect contact to be made between the fuse and the conductor, and the size of the parts should be such as will not permit too much conduction or radiation of heat. To insure good contact the fuse portions are often fastened

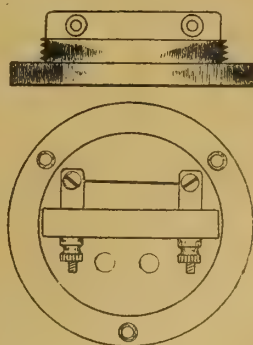

Fig. 58.

to copper contact tips or clips at each end, as shown in Fig. 55. For the smaller fuses the fuse wire is often wrapped round the terminal and secured by a nut. The contact area should be at least twice that of the sectional area.

(3) The base should be made of insulating and inflammable material.

(4) The whole should be provided with a non-combustible insulating cover if not for use on a fuse board placed in a box.

The materials of which fuses are generally made are tin, lead, or an alloy of 6 parts tin to 4 parts lead. And the point at which a fuse will break depends not only upon the material of which it is composed and upon the current passing, but also upon the length and sectional area, the temperature of the surrounding air, whether it is covered and to the degree of

exposure, and the nature of the contact at the clip.

As regards the length of a fuse wire, it is important to remember that whilst the fuse should blow with an excess of current, there should be no possibility of an arc forming when such does occur, and it is usual in practice to allow not less than 1 in. between the fuse terminals for 100 volts, and to allow 1 in. additional space between the terminals for each 100 volts in excess of 100 volts. And in considering the length of the fuse wire for the current strength, it is usual to allow 1 1/2 in. for 5 ampères and 1/2 in. for each 5 ampères in excess of the first 5 ampères. Usually wires are used for currents up to 30 ampères. In deciding upon the dimensions it must also be remembered that the resistance per unit length should be great compared with that of the conductor, so as to concentrate the heat in the fuse; but it should not be so great as to affect the resistance of the circuit, and so produce waste. From a large number of experiments made by Mr. Preece, the following formula has been deduced for finding the diameter of the fuse wire for a given current—

$$C = a d^2 \text{ and } d = \left(\frac{C}{a}\right)^{\frac{1}{2}}$$

Where  $d$  = diameter in inches,  $C$  = current in ampères, and  $a$  = a constant for the material used. When  $d$  is in inches, the following are the values for  $a$  :—

Platinum .....	4,750
Copper .....	10,244
Iron .....	3,148
Lead .....	1,379
Tin .....	1,642
Alloy (lead and tin 2 to 1) .....	1,318

Whilst considering the proper size of a fuse, it will be well to mention that much difference of opinion exists as to whether (1) the size should be proportioned to the current they are intended to carry, or (2) the size should depend upon the size of the smallest conductor they should protect;



Fig. 59.

and of the two the former is probably the better basis, and is the one recommended. The percentage of increase on the advisable normal carrying current at which the fuse should break, the General Electric Company have found to be approximately :—

For fuses up to 5 ampères .....	100 per cent.
"    "    10    "    .....	80    "
"    "    20 & 30    "    .....	50    "
"    "    50    "    .....	45    "
"    "    100    "    .....	35    "

Many insurance companies, however, fix the percentage of increase at 50 per cent. for all ordinary cases. Probably the best advice is that the actual size should be decided upon after an experimental trial has been made with the material to be used.

Fusible cut-outs are usually divided into single-pole, double-pole, main, and branch cut-outs. Fig. 56 shows a single-pole fuse and base, Fig. 57 a double pole for main circuits so that each main is protected, whilst Fig. 58 shows in plan a branch cut-out. It will be observed that in Figs. 56 and 57 a dividing ridge of porcelain is provided in connection with the base, so as to prevent short-circuiting, and to improve the insulation generally. To prevent oxidation, the fuse wire should be coated with shellac varnish; and we may mention here a very novel arrangement for insuring the fuse melting at the proper time, which was introduced by Cockburn, and is shown in Fig. 59. It is a weighted fuse, a pellet of lead being fixed as shown, which breaks the fuse wire as soon as it becomes soft, and so prevents uncertainty in the action of the fuse.

Generally speaking, fuses should be placed at the commencement of each pair of mains. On the main circuit, and as near the source of supply as possible, double-pole cut-outs should be used, care being taken that the fusible sections should not be in the same compartments. Fuses should also be placed at all branching points whenever a change in the gauge of the conductor occurs. Also, since an excessive flow of current would

fuse lamp filaments, each lamp should be protected by a fuse, which may conveniently be placed in the lamp-switch. In all cases it is a matter of importance that fuses should be placed at accessible points, and should never be placed under floors or

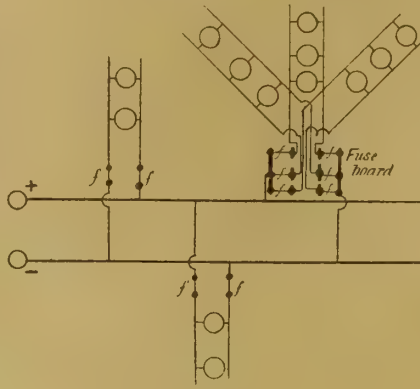

Fig. 60.

behind skirting boards, &c. In good work the practice is to use fuse-boards wherever possible, in which case a number of circuits are protected by separate fuses at the distributing point. Fig. 60 represents the disposal of fuses in practice. And whilst fuses must be used, it must be remembered that careless fixing and the injudicious use of fuses tends to a waste of energy.

Branches from all circuits should have fuse-boxes made of porcelain or other incombustible material on both poles, and the fuses in these fuse-boxes, if on the same base, should be in separate compartments. Where the tree, or tapered, system of wiring is allowed, fuses should be introduced at such intervals that each fuse protects the smallest branch between it and the next fuse; or, if there is no other fuse, then it must protect right up to the end of the circuit. If the above precautions are taken, it is not necessary to protect the ceiling roses which support flexible pendants, by fuses at the ceiling point of junction.

Whenever circuits not exceeding 5 ampères have fuses in each pole at the distributing point, fuses in the connectors are not necessary; should the current, however, exceed 5 ampères up to 125 volts, or 3 ampères up to 250 volts, all portable fittings requiring flexible cords, or adapted fittings wired with flexible cords, must be protected with a fuse at the point of junction with the circuit.

Where one of the conductors is connected to earth, all switches and fuses which will be single-pole should be arranged on the insulated side of the system. No fuses or switches should be placed in or at any point of the earthed conductor. Standard types of fuses should be so designed as to avoid the risk of inserting fuses intended for large circuits into the fuse carriers of small circuits, and vice-versa. The covers of all fuse-boxes, whether these be separate or grouped on switch-boards—should be efficiently ventilated, so as to avoid risk of fracture by the sudden expansion of the air within them at the time the fuse melts, the covers being arranged to catch and retain the fused metal.

(To be continued.)

THE CLERKS OF WORKS' ASSOCIATION.

THE fifteenth annual dinner of this association was held at the King's Hall, Holborn Restaurant, on Monday evening, and was well attended. Mr. W. H. Seth-Smith, F.R.I.B.A., occupied the chair. Mr. John Brady proposed the toast of "The Architects and Surveyors," remarking that, while the architect was the best friend of the clerk of works who did his duty, or even made an approach to so doing, the surveyor understood the details of a builder's work better than anyone else who came upon the job—in fact, he claimed that the capable surveyor was a born clerk of works. Mr. G. H. Fellowes Prynne, F.R.I.B.A., in the course of an eloquent response, observed that in that association architects recognised a great guarantee for the proper supervision of their work. The clerk of works was the eye of the architect, and carried his reputation in his hand. The architect could not be expected by the client to look after every

detail of the work; this task had necessarily to be delegated to the clerk of works, whose responsibilities were consequently enormous. Mr. Alan Paul, F.S.I., also responded. Mr. W. S. Woolcott, past-president, proposed the toast of "The Worshipful Company of Carpenters." Mr. Stanton W. Preston, the clerk to the company, in replying, said that during the twenty-one years he had been its clerk, the company had risen from comparative obscurity to an important position as a leading City guild. When they built their hall in London Wall, they decided to use it for promoting the welfare of the building trades as far as their means would allow. They organised exhibitions at which the quality of work submitted had steadily improved; courses of free lectures on subjects important to the building trades were instituted, and had been well attended; a series of workshops had been built on part of their estate at Stratford, where they trained 160 boys in the day and 280 in evening classes; and, lastly, they established the Technical Schools in Great Titchfield-street, W., which was now attended by 265 young men, it being made an essential that each student should be actually engaged in the trade taught. In conclusion, he referred to the valuable assistance rendered by the secretary to the association, Mr. F. Dashwood, and their successive presidents in carrying out the company's examinations. The Chairman then gave the toast of the evening, "Prosperity to the Clerks of Works' Association," coupled with the name of Mr. P. J. King, the president. Mr. King responded. The remaining toasts were "The Visitors," proposed by Mr. E. W. Nightingale, past-president, and acknowledged by Messrs. H. T. Hare and L. W. Solomon; "The Press," proposed by Mr. A. S. Flower, and responded to by Mr. W. T. Plume; "The Hon. Treasurer, Mr. J. Oldrid Scott," given by Mr. Spooner and acknowledged for Mr. Scott by Mr. Edmunds; and "The Chairman," proposed by Mr. J. G. Peacock.

THE METROPOLITAN ASYLUMS BOARD SOUTHERN HOSPITAL COMPETITION.

WE give now the names and addresses of the architects invited to compete for this building. This information, as we stated a few weeks since, was refused to us by the clerk to the Board on the somewhat curious ground that it was unfair to competitors that they should know against whom they were competing! As we then stated, somebody knew the names of the competitors, and was already writing to them offering to assist them in the preparation of their designs:

- H. P. Adams, 28, Woburn-place, W.; Arthur Ardron, 8, Delahay-street, Westminster; C. O. Ellison and Son, 22, Sir Thomas-street, Liverpool; Giles, Gough, and Trollope, 28, Craven-street, W.C.; Greenaway and Smith, 21, Queen Anne's Gate, S.W.; E. T. Hall, 57, Moorgate-street, E.C.; John Harvey, 47, Victoria-street, S.W.; B. S. Jacobs, Lincoln's Inn Buildings, W.C.; M. Macartney, 52A, Berkeley-square, W.; Newman and Newman, 31, Tooley-street; Pennington and Son, Hastings House, Norfolk-street, W.C.; Smith and Croggin, 14, York-buildings, Adelphi, W.C.; E. Thomas and Son, 7, Queen Anne's-gate, S.W.; Treadwell and Martin, 2, Waterloo-place, S.W.; Woodd and Ainslie, Broad Sanctuary Chambers, Westminster.

The competition has some objectionable features about it which will probably lead to unpleasantness. We think, for instance, the following clause in the "Terms of appointment" sent out by the Board is a very unfair one :—

Any dispute or question between the architect and the Managers shall be referred to an arbitrator appointed by the Managers, who shall have such powers and authority as the Managers may think fit to give him, &c., &c.

A condition of this kind, once accepted, leaves the architect entirely at the mercy of the managers. We believe it has not been accepted by all the competitors without protest; but we should like to have been able to say that all had sufficiently valued their professional independence to join therein.

The work of re-hanging the bells and providing chimes for the clock has now been completed as part of the Canterbury Cathedral restoration scheme. The inauguration of the bells and chimes took place on Saturday.

The technical institute at Grantham was opened by Earl Brownlow last week. The premises were till recently a disused cigar factory, near the Guild-hall, and the alterations and refitting have cost about £1,000. The whole of the structural alterations have been executed by Messrs. Walker Bros. and Parks, of Grantham, from plans drawn by the borough surveyor, Mr. F. Morris.

## Building Intelligence.

**EXMOUTH.**—The new church of All Saints, Exeter-road, Exmouth, was dedicated on Wednesday week. It is in the Pointed style of architecture and is built of Berry Head limestone, with windows and doorways in Bath stone. The piers of the arcades are of Polyphant polished stone. The flooring of the chancel is of marble and marble mosaic, with solid wood block flooring elsewhere. In plan the church consists of nave, north and south aisles, north and south transepts, chancel, morning chapel (occupying the site of the future tower), baptistery, organ chamber, and vestries for the clergy and choir. There is sitting accommodation for about 700 persons. The cost of the building will be about £8,000, exclusive of the tower. The seats are of unvarnished pine. Among the special gifts are the alabaster reredos, the font, and organ. The architects are Messrs. Tate and Harvey, of Exeter; while the builders are Messrs. Luscombe and Son, with Mr. J. Pullen as clerk of works.

**LIVERPOOL.**—The corner stone of the new building for the Royal Insurance Company in North John-street was laid on Friday by the chairman of the directors. The architect is Mr. J. Francis Doyle, of Liverpool, whose plan was put first in competition by the assessor, Mr. Norman Shaw, R.A. The style is Classic, adapted to modern requirements. The sub-structure will be of grey Aberdeen granite to a height of 30ft. above the pavement level. The superstructure will be composed of white Portland stone, and roofed with green slates. To the Dale-street front will be a gable rising 110ft. above the pavement. In North John-street will be placed the main entrance, which will be surmounted by a tower 150ft. high. At the south end will be the entrance for tenants, which also has a tower, but of less importance. A feature in the building is the steel construction, introduced to obviate the necessity of columns on the ground floor, which for the entire length will be utilised as the general offices of the company.

**MOSELEY.**—The parish church was reopened yesterday (Thursday), after undergoing considerable enlargement, upon a plan adapted to further developments at some future time. The alterations have been designed by Mr. J. A. Chatwin, whose plan provides a large chancel, a chancel aisle, and also a south transept, which will provide 100 additional sittings. It is proposed hereafter to divide the present body of the church into a well-proportioned nave and south aisle, and to form large clerestory windows. The east window consists of seven lights, so constructed as to bring in the three stained-glass windows of the former chancel. The chancel and transepts externally are faced with Bromsgrove stone. The floors are laid with wood blocks, while the portion of the chancel within the altar-rails is paved with glass mosaic. The roofs are covered with slate. Messrs. Collins and Godfrey, of Tewkesbury, were the contractors. The outlay has been between £2,000 and £3,000.

**STOCKPORT.**—The board of guardians of the Stockport Union considered, on Monday, eight tenders for the erection of the proposed new workhouse at Stepping Hill, near Hazel Grove. The highest tender was £160,467, and the lowest £138,476. A committee had previously opened the tenders and recommended, by eight votes to four, that the work should be divided into two contracts, and that the tender of Messrs. T. and W. Meadows, of Stockport, for No. 1 section of the buildings at £68,614, and for the roads at £4,362, and the tender of Messrs. Storrs, Sons, and Co., Limited, of Stalybridge, for No. 2 section of the buildings at £63,163 be accepted. The chairman said there was a private letter on the subject to the clerk. The representatives of the Press were requested to leave the Board-room whilst the letter in question was read to the guardians. Upon their readmission the vice-chairman said that the architect (Mr. W. H. Ward, of Birmingham) had told them they might let the two sections separately, and now there was a letter to a different effect. It was very mysterious indeed. It was ultimately proposed to adopt the recommendation of the committee, and an amendment was moved to give all three contracts to Messrs. Meadows. The amendment was defeated by 23 votes to 11. A further amendment, to adjourn the question to a special meeting of the board and to request the architect to be present, so that he might be given an opportunity of

explaining why he now asked the majority of the building committee to "eat their own words," was passed by a large majority.

### CHIPS.

Mr. George Cartledge, headmaster of the Rochdale School of Art, has been appointed headmaster of the important art school at Hanley, his native town. Mr. Cartledge has been in Rochdale only about 18 months. He succeeded Mr. R. B. Dawson on that gentleman's removal to Kidderminster.

The City Art Gallery at Manchester was reopened to the public on Monday. The permanent collection has been transferred to the eastern side of the building and rearranged.

Mr. Ogden has been elected headmaster of the school of art at Canterbury, in succession to the late Mr. H. Allen.

At the quarterly meeting of the Inverness District Asylum Board on Friday tenders for the construction of additions to the Inverness Asylum were accepted at £13,141. A total of £25,000 has been expended during the past two years on the extension of the building, the demands upon which have greatly increased.

There was a very large gathering in the Central Hall of the new Mount Pleasant Schools, Southampton, on Thursday in last week, when Sir George Kekewich, G.C.B., performed the opening ceremony. The architect was Mr. J. H. Blizard, architect to the Southampton School Board, and his designs have been carried out by Messrs. H. Stevens and Co., contractors, of Southampton.

On Friday last, at the Grosvenor Hall, Buckingham Palace-road, between 300 and 350 employes of Messrs. Drake and Gorham and their friends attended a smoking concert organised for the staff, and a very pleasant evening was spent. Mr. Drake stated that 1897 had been the firm's record year in turnover, in spite of increasing competition, and that during the past 12 months £1,000 had been distributed among the employes in the form of bonuses.

Mr. James F. Smith, one of the best known civil engineers in Pennsylvania, died at Reading, Pa., January 31. He was born in Pittsburg and started in his profession in 1831, when he was appointed assistant civil engineer of the Allegheny Portage Railroad. He was chief engineer of the Schuylkill Navigation Company from 1850 to 1876, and during the later years of his business life was consulting engineer of the Philadelphia and Reading Railroad Company. He retired from active life about 10 years ago.

Last week was a quiet one at the Auction Mart, Tokenhouse-yard, and it is noteworthy that there is less demand than recently for freehold ground rents. The aggregate realisation for the week was £47,740, as against £70,770 registered for the corresponding week of 1897, but this week an unusually large number of investments have been placed on the market, and have on the whole realised fair prices.

At the last quarterly meeting of the Corporation of Ipswich, another handsome gift to the town was accepted—that of premises in St. George's-street at the rear of the museum, a property which was purchased by the late Alderman Sterling Westhorpe, with the intention of adding it to the museum, and is now presented by his executors. This will enable the museum buildings to be carried through from High-street to St. George's-street.

The Roman Catholic Church of St. Joseph, Huddersfield, erected in 1894, was reopened on Sunday after having undergone a course of total redecoration and ornamentation after Florentine designs. The alterations and additions have been worked by Messrs. Crasso, of Belgium. The decorations include ornamentation of the sanctuary, with the figure of the "Sacred Heart," and fourteen pictures on the walls of the Stations of the Cross.

Glasgow Dean of Guild Court have passed the plans for three tenements of shops and dwelling-houses and a public wash-house which are to be erected in the Calton district by the Improvement and Police Departments of the Corporation. The tenement, which will be four stories in height, will comprise room-and-kitchen and single apartment houses, rented at from £7 15s. to £11. The cost is estimated at £7,270. The wash-house, which will be erected to the rear of the tenement, will be 76ft. long by 75ft. broad, and will contain 44 stalls. The architect is Mr. A. B. McDonald.

Peterborough Town Council having applied to the Local Government Board for sanction to borrow £15,000 for purposes of electric lighting, Mr. W. O. E. Meade King, M.Inst.C.E., has held an inquiry at the instance of the Local Government Board, at the Guildhall, Peterborough. In answer to the Commissioner, the Town Clerk stated that the population of Peterborough was now 30,000.

### PROFESSIONAL AND TRADE SOCIETIES.

**ARCHITECTURAL ASSOCIATION OF IRELAND.**—On Tuesday evening a meeting of the Architectural Association of Ireland was held at the Grosvenor Hotel. Mr. Cecil Orr, A.R.I.B.A., delivered a lecture on "The History of Architecture." The lecturer first showed the origin of design from natural objects, and the rise of Greek architecture from Egyptian and Assyrian work. He pointed out that Roman architecture was a development of Greek work united to the architecture which they had got from the Etruscans. He next showed how Constantine the Great had transplanted the Roman arts to Constantinople, his new capital, where they became united with the eastern work of the Sassanians and Phœnicians. Here Mr. Orr broke off his treatment of European work, with the remark that the native work of Ireland was derived not from the Byzantine school, but from the common origin with the Phœnicians through Carthage. He then dealt at some length with Moorish architecture. In his second lecture Mr. Orr will deal with the development of Gothic architecture.

**EDINBURGH ARCHITECTURAL ASSOCIATION.**—At a meeting of this association, held on February 9, the president (Mr. Thomas Ross) in the chair, Mr. James A. Williamson, past president of the Architectural Society, read a paper on "The Vernacular of the Wren School," illustrated by limelight views. The lecturer gave an historical resumé of the Renaissance in Great Britain from the earliest period of its influence, in the reign of Henry VIII., till the beginning of the 17th century, when the architectural authority of Inigo Jones became paramount. Mr. Williamson stated that Inigo Jones was the first Englishman to grasp in its full significance the art of the Italian Renaissance. The works of Inigo Jones were minutely described, particularly the palace at Whitehall for James I. This work, the lecturer considered showed that Jones possessed a complete mastery of proportion, a keen sense of the balance of voids and solids, and full knowledge of the value of chiaroscuro. He was one of the most brilliant architectural designers this country had ever produced. Sir Christopher Wren, as the acknowledged head of the school, was next dealt with in an exhaustive manner, and his several outstanding achievements in design described in detail, notably St. Paul's, Hampton Court Palace, St. Mary-le-Bow, and Walbrook. Mr. Williamson claimed that Wren founded a strictly vernacular school of architecture based on the principles of Italian Renaissance, and that, never having visited Italy, he approached the study of his great works with a mind free from the trammels of precedent, in which, perhaps, the instinct of the engineer rather than the artist predominated. After a further detailed reference to the successors of Wren, including architects such as Nicolas Hawksmoor and Vanbrugh, the lecturer concluded by referring to the eclectic and cosmopolitan character of the architecture of the present day, arguing in favour of a return to the best examples of the Wren school, with a view to a logical development of the spirit then in force towards perfection on traditional and vernacular lines.

**NORTH OF ENGLAND FEDERATION OF MASTER PAINTERS.**—The annual meeting of this federation was held at the Star and Garter, Middlesbrough, on Monday, under the presidency of Mr. Wm. Allan. The secretary, in his annual report, stated that at the end of 1897 there were 135 members, and he believed that now there were 155. The treasurer presented a report, which showed a balance in hand of £5 7s. The report and balance-sheet were adopted. The president expressed the pride and pleasure he had felt in occupying the position during the first 18 months of the federation's existence. They had federated with them every local association in the North of England, except one at Bishop Auckland, which they expected would soon join them. They hoped also to see a local association formed at Darlington. He moved that the president for the ensuing year be Mr. John Scott, of Middlesbrough. This was carried unanimously. Mr. J. G. Cole (Newcastle) was elected vice-president, Mr. Wm. Allan (South Shields) was elected treasurer, and Mr. R. G. Salmon was elected secretary.

**PORTSMOUTH MASTER BUILDERS' ASSOCIATION.**—The annual meeting of this association was held on Tuesday last at the Sussex Hotel, Land-

port. Mr. C. Dye, T.C., the chairman, retired in the usual course, and Mr. J. H. Corke, J.P., was elected for the ensuing year. Mr. A. E. Porter was appointed vice-chairman, Mr. C. Harding treasurer, and Mr. F. Simpson secretary; Messrs. C. Dye, H. Jones, J. Cockerell, W. Light, C. Reading, W. W. Evans, and J. W. Perkins were elected on the committee. Among the matters discussed and referred to the new committee was the demand for increased wages by the men, the notices in connection with which expire on May 1.

#### CHIPS.

A new clock, built by Messrs. John Smith and Co., of Derby, has just been placed in the parish church of Cheriton Fitzpaine, Devon.

Dr. Collins, Chairman of the London County Council, on Saturday opened an extensive block of buildings which has been added to the Woolwich Polytechnic. The new buildings, which, with the equipment, have cost about £6,000, are intended to accommodate students in chemistry, physics, and art.

The Admiralty have just accepted a tender for the enlargement of the Royal Naval Barracks at Keyham to provide the accommodation that will be required when the extensive dock works in progress are completed. The addition to barracks will be for a thousand men, and with a new set of officers' quarters. The work will be taken in hand forthwith, and is to be finished in three years. The capacity of the barracks will be doubled. Mr. A. R. Debnam, of Mount Pleasant, Plymouth, has taken the contract, and the work will be carried out under the supervision of Major H. Pilkington, C.B., R.E., the engineer-in-chief of the Navy Loan Works.

In a report posted at Tuesday's meeting of the London County Council, particulars were given by the Bridges Committee with respect to the design for the new Vauxhall Bridge. Sir A. R. Binne has prepared a design for a granite bridge backed with concrete, a principle adopted by his predecessor, Sir J. W. Bazalgette, in New Putney Bridge. This will save about £1,000 a year in the painting required by an iron bridge of equal dimensions. The estimate is £380,000, with a possible reduction of £20,000.

In an application for an ejectment order against a tenant of a house in Outer Moss-lane, Morecambe, made to the Lancaster County Bench on Saturday, it was stated that although the house had been recently built, the walls were cracked from top to bottom, and the district council had declared it to be dangerous.

The Local Government Board report on the Ruskington waterworks question, based upon the evidence taken at the recent inquiry held before Colonel Langton Coke, C.E., decides that the Ruskington Urban District Council are in default, and allows three months only in which the council must construct a reasonable scheme of waterworks for the parish.

After a prolonged discussion the urban district council of Weston-super-Mare finally adopted at the last meeting the plans of Messrs. Stewart and Grace, selected and premiated in the recent competition, for the proposed pavilion and accessories at Knightstone, but the plans are to be amended and reduced. Mr. Stewart expressed his willingness that the conditions and terms of remuneration specified in the original conditions of competition should apply to his amended plans, and that the commission should be reduced to 2½ per cent. for the preparation of plans, specifications, estimates, and attending public inquiry, &c., exclusive of all out-of-pocket expenses, in the event of the project not being carried out.

At Tamworth a new board school for boys, built in the Leys at a cost of £7,000, was opened on Thursday in last week. The school is on the central hall plan and accommodates 500 scholars. During the proceedings a vote of thanks was passed to the architects, Messrs. W. and J. Goodacre, Leicester; and to the contractors, Messrs. C. Clarson and Son, Tamworth.

The new line in Leith of the North British Railway Company will be proceeded with very shortly. The line leaves the company's system at London-road junction signal cabin, below Abbeyhill Station, and proceeds in a northerly direction to the foot of Leith Walk. At the junction of Leith Walk with Duke-street a large passenger station will be erected. Messrs. Young and Sons, of Edinburgh, have taken the contract at between £90,000 and £100,000.

The *Tablet* says that the reports which have been circulated concerning the legacy left to the Bishop of Liverpool by the late Mr. James O'Byrne, architect, of Liverpool, have greatly exaggerated its amount. The residue of the estate left to the R.C. Bishop of Liverpool amounts to between £40,000 and £45,000.

#### COMPETITIONS.

**BELPER.**—At the last meeting of the rural district council, it was stated that from competitive schemes for the water supply of Crich and South Wingfield which they have received, that of Mr. W. H. Taylor, of Birmingham, had been selected. He proposed to give water for Crich at an estimated cost of £2,790.

**BOOTLE.**—At the last meeting of the town council, a committee brought up a report recommending the adoption of the award by Mr. Turton, of Liverpool, the assessor in the competition for the fire-brigade station. He recommended that the plan numbered 14 be placed first and be adopted for execution, subject to the conditions of competition and instructions to architects, and to any modifications in points of detail which the joint committee may consider desirable. Design No. 1 was placed second in order of merit. The report was adopted, an endeavour to refer the matter back to the committee being defeated, and on opening the sealed envelope it was found that the successful competitor was Mr. C. J. Anderson, of Dale-street, Liverpool. The limit of cost is £15,000.

**TAUNTON.**—Designs for a town-hall are invited by the market trustees, premiums of £100, £50, and £30 being offered for the three best designs. Mr. Edward W. Mountford, F.R.I.B.A., of London, has been appointed professional assessor.

**WOLVERHAMPTON.**—The referee, Mr. Alfred Waterhouse, R.A., has this week made his examination of the designs submitted in the select competition for the Public Library to be built as a Jubilee memorial on a fine site facing Snow Hill, Wolverhampton. The plans were sent in last Monday, and on Wednesday the committee confirmed the award which accords the first premium to Mr. H. T. Hare, and the second to Mr. J. M. Brydon. The drawings are to be on view during the next seven days to the public. The total cost, including premiums, architect's fees, measuring-up the building when finished, and all fittings, electric lighting and warming, is limited to £10,000. Nine sets of designs were received.

The school board for Littlehampton have appointed Mr. Leonard Stokes, of Spring-gardens, as assessor in a competition for a boys' school, the fee to be paid being thirty guineas.

The Scottish National Gallery, which for a month past has been undergoing a thorough overhauling, has been reopened to the public this week. Two new and important pictures have been added to the collection—a Raeburn and a Hogarth. The Raeburn is a legacy from Lady Riddell, of Kilcamb, Strontian, and is a portrait of Mrs. Campbell, of Ballimore; the Hogarth is a legacy from Lady Jane Dundas, and is a cabinet portrait of Sarah Malcolm, a criminal, who was executed in 1733; she is portrayed as seated in her prison cell, with a cross and string of beads lying on a table in front of her.

On Saturday, February 5th, the foundation-stone of a new church, to be known as St. Peter's, at Beeston, a suburb of Nottingham, was blessed by the Right Rev. Mgr. McKenna, V.G. The church, which is being erected by Mr. Turner, a local builder, from the plans of Mr. Hart, of Corby, will seat about 150, and cost with the site (800sq.yds.) a little over £600.

Mr. George Armstrong Howitt, sculptor, passed away at his residence, 13, Prince-street, Gloucester, on Tuesday week, at the age of 86 years. Mr. Howitt was a native of Gloucester, and was apprenticed to a sculptor. One of the earliest works he was engaged on was the statue of the Rev. Richard Raikes in the cathedral. Subsequently he was engaged by Sir Digby Wyatt, whom he assisted in church and mission work in various parts of the country; and he also acted in a professional capacity to the Marquis of Ailesbury, the Marquis of Lansdowne, and Lord Falmouth. He retired some 17 years ago. He was awarded the Royal Polytechnic Society's set of medals for portrait heads carved in oak, walnut, and boxwood.

The members of the Glasgow Building Trades' Exchange held their first annual dinner on Thursday night in last week, in the Windsor Hotel, St. Vincent-street. Colonel Robert J. Bennett, president, occupied the chair, and the croupiers were Mr. Alexander Gray, Mr. Alexander Muir, and Mr. John Paterson. There were about 120 gentlemen present. Mr. Peter Lawrence proposed the toast of the evening, "Glasgow Building Trades' Exchange," which was acknowledged by the chairman. Mr. John Laird gave "The Merchants' and Trades' Houses of Glasgow," and the Lord Dean of Guild and the Deacon-Convener replied.

#### PARLIAMENTARY NOTES.

**THE SOUTH KENSINGTON COLLECTION.**—Sir F. Powell asked the First Commissioner of Works on Monday what steps the Government had taken to carry out the recommendations of the select committee of last session on the museums of the Science and Art Department for the protection of the collection at South Kensington from the imminent risk of fire; and whether they were prepared without further delay to proceed with the completion of the permanent buildings in accordance with the recommendations of the second report of the same committee. Mr. John Burns also asked a question on the same subject.—Mr. Akers-Douglas: The old buildings known as the "Boilers," the temporary building in the inner quadrangle, and the students' refreshment-rooms have been removed. Various other works are in hand, including the fireproofing of the room next the Raphael Gallery, and the improvement of the southern galleries on the west of Exhibition-road. The private residences of the officials are to be abolished. These, in the opinion of the Government, comprise all the matters of urgent necessity, in view of the fact that a proposal for proceeding at once with the permanent buildings will shortly be laid before Parliament.—Mr. Burns asked whether they were to assume that "at once" meant the current year?—Mr. Akers-Douglas: I have every reason to hope so.

The corporation of Colchester have adopted amended designs for the rebuilding of the Town-hall, submitted by Mr. John Belcher, F.R.I.B.A., of London, whose design was placed first in the recent competition, and have appointed Mr. Belcher architect on the terms previously arranged for.

A Local Government Board inquiry has been held at Bishopstoke, by Colonel Durnford, R.E., with reference to an application by the Winchester Rural District Council for permission to borrow £5,000 for the purpose of carrying through a sewerage scheme for the parish of Bishopstoke.

At the weekly meeting of the London County Council on Tuesday, the Building Act Committee recommended that Mr. Andrew Moseley, who has been district surveyor for Fulham for nearly 54 years, should be called upon to resign his position.

At the last meeting of the Glossop Town Council the plans were estimated of a technical school which Lord Howard of Glossop proposed to build on a site opposite the free library, the architects being Messrs. Douglas and Minshall, of Chester. The schools will be three stories high, and large rooms have been allocated for classrooms, laboratories, &c. The plans were approved, and a resolution thanking Lord Howard for his generous gift was passed.

The designs submitted by Mr. T. G. Jackson, R.A., and Mr. T. Brock, R.A., for the Benson monument in Canterbury Cathedral having been accepted by the committees of the memorial fund, the execution of the altar tomb has been commenced. The recumbent effigy of the late Primate will represent him in an attitude of prayer.

The east window of Ripon Cathedral is being rearranged as a memorial to Dean Fremantle, and two brasses have been placed underneath. Mr. A. O. Hemming, of Margaret-street, W., is executing the work under Sir Arthur W. Blomfield, A.R.A.

At the Manchester Assizes on the 10th inst., an action was brought by Dr. G. C. Kingsbury, of Blackpool, against Mr. George H. Willoughby, a Manchester architect, to recover damages for slander. Some interesting revelations in regard to hypnotic medical treatment were disclosed during the hearing of the case. The jury gave a verdict against the defendant, damages 20s. and costs.

The new temporary hospitals for the Guardians of the Rochdale Union are being warmed and ventilated by means of Shorland's patent double-fronted Manchester stoves, with ornamental tiled sides, the same being supplied by Messrs. E. H. Shorland and Brother, of Manchester.

Mr. R. Norman Shaw, R.A., has accepted the position of architect to the Westminster Improvement Scheme, and Mr. Edward L. Lutyens will be associated with him in advising the promoters of that extensive project for rebuilding the dilapidated properties and embanking the river between the Victoria Tower and Lambeth Bridge.

The design submitted by Mr. T. F. Pennington, of Castleford, has been accepted in a limited competition for a Wesleyan chapel and Sunday-school to be built at South Kirkby, near Pontefract. The chapel is to accommodate 350 persons, and the schools 200 children; the style adopted is Free Gothic, the materials will be brick and stone, and the cost will not exceed £1,500.

The Ayr Town Council decided on Monday, after two hours' discussion, to proceed with the erection of the new town hall on the old site, at a cost of £15,500, which includes £3,200 for additional property to increase the size of the hall and provide additional exits.

CONTENTS.

Neglected Features ... 223  
 The Dudley Gallery Art Society Exhibition ... 223  
 A Coat of Paint.—II. ... 224  
 Sewage Purification: The Salford Experiments ... 225  
 Examples of Greek and Pompeian Decorative Work ... 225  
 Electric Lighting Notes for Architects.—XVII. ... 226  
 The Clerks of Works' Association ... 223  
 The Metropolitan Asylums Board Southern Hospital Competition ... 228  
 Building Intelligence ... 229  
 Professional and Trade Societies ... 229  
 Competitions ... 230  
 Parliamentary Notes ... 230  
 THE BUILDING NEWS DIRECTORY ... XIII.  
 Our Illustrations ... 231  
 Stained Glass ... 231  
 Correspondence ... 250  
 Intercommunication ... 251  
 Legal Intelligence ... 251  
 Our Office Table ... 252  
 Meetings for the Ensuing Week ... 253  
 Trade News ... 253  
 Latest Prices ... 253  
 List of Competitions Open ... 254  
 List of Tenders Open ... 254  
 Tenders ... 257

ILLUSTRATIONS.

NEW PREMISES, GOSFIELD STREET, W.—SECOND PREMIATED DESIGN FOR CHESTERFIELD SCHOOLS AND BATHS.—PROPOSED CHURCH AT CRESSWELL.—SILVER MEDAL STUDIES OF ANIMAL LIFE TREATED FOR DESIGN.—HOUSE AT SURBITON.—SKETCHES FROM DIEPPE.—TWO SOMERSETSHIRE PULPITS.

Our Illustrations.

NEW PREMISES, IX. AND X., GOSFIELD STREET, W.  
 THE above building contains the sets of small flats of two and three rooms each, with a separate w.c. to each set of rooms. On the top of the 4th floor is a washhouse for the use of all the tenants generally. The roof is flat and covered with asphalt, this being laid on Messrs. Stuart and Co.'s granolithic roof. The front is in picked yellow stocks, the quoins, heads, &c., in red bricks, and the stonework is Portland. The lower portion of the jambs to entrance-door are in glazed brown bricks. The contract was let for £1,863 6s. 2d. to Mr. James Carmichael, who carried the work out. The stairs from top floor to basement are in granolithic. The architect is Mr. W. Hargreaves Raffles, of 9, Argyll-street, Regent-street, W.

SECOND PREMIATED DESIGN FOR THE CHESTERFIELD SCHOOLS AND BATHS.

THE elementary school proper is placed at the rear of the block at the same level as Brewery-street, and reached by separate entrances for males and females, which pass over the swimming-bath. The bath has been placed well to the front to afford facility for the use of the public. Care has been taken in the planning of the buildings to insure the carrying out of the future extensions, so that the whole may be a complete and compact scheme. The accommodation for the instruction in cooking and laundry work has been planned in the basement, and is reached from the main school floor by two fireproof staircases, which are also used for the swimming and slipper-baths by the children. Separate entrances to swimming and slipper-baths are also provided, so that the public in using the baths do not interfere with the ordinary working of the school. The buildings were to be constructed in brick; the exterior to Brewery-street of red pressed brick and stone; best green slates are to be used on roofs. The internal walls of rooms to be lined with glazed brick from floor to ceiling; staircases and passages to have a dado of brown glazed brick, the upper part to be in white glazed brick. The swimming-bath is to be lined with white glazed brick. This scheme was submitted by Messrs. Hall, Cooper, and Davis, architects, Scarborough, and was placed second by the assessor, Mr. E. R. Robson, Messrs. Houston and Houston, London, taking the first premium. We understand the board has now accepted an amended plan by a local architect, which they intend to carry out.

PROPOSED CHURCH, CRESSWELL.

MESSRS. BREWELL AND BAILY are the architects, whose drawing of this building we are illustrating to-day. No particulars of the work have come

to hand, and the plan accompanying the view shows the contrivance of this picturesque church.

STUDIES OF ANIMAL LIFE TREATED FOR DESIGN: THE ARCTIC TERN.

THESE silver-medal drawings, by Mrs. M. E. Dawson, are devoted to decorative studies of the Arctic Tern, whose graceful flight is extremely beautiful, and the elegant proportions of the bird lend themselves exceedingly well for treatment in ornamental or mural design. The Japanese have utilised bird-life, of course, in all its divergences, though seldom with more success than in the employment of aquatic fowls. Mrs. Dawson, in a way, appears to reflect the type of design to which this passing note refers, and, while not hesitating to conventionalise her pencil, may be said to be always true to nature.

HOUSE AT SURBITON.

SOME capital examples of picturesque house-building have of late years been carried out in the district round about Surbiton. The design herewith illustrated was sent us some time ago by Mr. Walter E. Hewitt, when we gave another view of the same residence. The walls, in red brick below, have tile hanging above. The windows are mullioned in wood; but the porch is in stone, while the roofs are all covered with tiles.

SKETCHES FROM DIEPPE.

THE Castle of Dieppe occupies a commanding position at the western end of the town, the towers illustrated being in the front, at the extremity facing the sea. The bulk of the building is built of greystone, with bands and patches of red brickwork, these last being of somewhat recent date. The building was erected in 1435, but was greatly damaged—almost destroyed—at the bombardment of Dieppe by the English in 1694. The gateway shown in one of the sketches is a side entrance. The castle was, some few years ago, converted into a barrack, when the large windows became a necessity. The old half-timbered house attracts the attention of all who arrive at Dieppe by boat. It stands on the quay on the Le Pollet side of the harbour entrance. The house is, unfortunately, in a somewhat ruinous state, and its appearance is not enhanced by one side being covered with a large advertisement of the local golf club. The two crosses, one at the cathedral, and the other at the church of St. Remi, are in the squares adjoining these buildings. They are of granite, and not very elaborate. That at the cathedral is the richer one, probably because it adjoins the more important building.

J. H. CORAM.

TWO SOMERSETSHIRE PULPITS.

THESE two richly-carved and ornamented pulpits are taken from the two neighbouring churches of South and East Brent respectively, each being of oak in good preservation, and octagonal on plan. The pulpit at East Brent is entered by a staircase through the thickness of the nave wall, to which is attached the panel, having incised upon it the initials "I.C.B.B." and the date 1634, which is probably about the date of the other as well. The interior of East Brent has a very fine appearance, having other work beside the pulpit of an interesting nature—namely, in its carved bench ends, organ gallery, wall frescoes, and very fine ceiling. The church of South Brent is not otherwise of much interest. The sloping floor of the nave is peculiar, the western end being considerably lower than the eastern.

E. RODWAY.

At St. John's Church, Newcastle, County Down, the memorials to the Seymour family and other improvements were dedicated on Wednesday week by the Bishop of Down, Connor, and Dromore. The church, which was built by the late Earl of Annesley in 1832, has been beautified internally. The walls have been coloured, and pomegranate foliage and flowers, conventionally treated, are used as a dado. A moulded plinth course of Italian marble forms the step to the communion-table, and at a lower level double steps and risers have been placed. All the marble work was supplied by Messrs. S. and T. Hastings, monumental sculptors, Downpatrick and Newtownards. The memorials consist of a brass telescopic communion rail, with six standards, supplied by Messrs. M'Gloughlin and Co., Dublin; panelled wall tiling of chancel, in design of raised vine leaves and bunches of grapes, supplied by Messrs. Craven, Durnill, and Co., Shropshire; and a brass tablet on the riser of step leading to the communion rail. Messrs. T. and F. Neill, contractors, Newcastle, had charge of the general improvements.

STAINED GLASS.

DOWNPATRICK.—The Down Cathedral Board have decided to reconstruct the east window in their cathedral. The window is in a dangerous condition, much of the stonework, which was erected in 1784, being defective, and likely to come down should there be a gale from the east. Its restoration has been intrusted to Messrs. Hastings and Crickard, of Downpatrick and Newtownards. Much of the stonework will have to be entirely replaced, and the remainder rechiselled. It has been decided to fill the window with stained glass. The design of Messrs. Ballantyne and Gardiner, of Edinburgh, submitted by Messrs. Hastings, was accepted by the board. In the rose light at the top of the proposed window will be a figure of our Saviour; in the quatrefoils below figures of SS. Peter and Paul seated. The figures in the other ten lights are SS. Matthew, holding the volume of his Gospel, John, Simon, Andrew, James, Philip, Thomas, Bartholomew, James the Less, and Matthias.

CHIPS.

The first anniversary of the reopening services at St. Saviour's Church, Southwark, after the rebuilding of the nave from Sir Arthur W. Blomfield's designs, was celebrated on Wednesday. A chancel screen, designed by Sir A. Blomfield—the gift of Mr. Robert Barclay—and a new clock for the tower, presented by Sir Frederick Wigan, will shortly be placed in the church.

The Markets Committee of the Wolverhampton Corporation have issued a report with reference to the condition of the Cattle Market. Its state has been condemned by every inspector of the Board of Agriculture. They recommend a number of improvements, the erection of slaughter-houses, and a house for the superintendent, at an estimated cost of £6,158.

The new Queen's Theatre at the corner of Clarence-street and Groundwell-road, Swindon, was opened last week. The building has frontages of 119ft. by 90ft., with free access on three sides, the site abutting on the main thoroughfare between Old and New Swindon. The style is Free Renaissance, and accommodation is provided for 1,600 persons. Messrs. Milverton-Drake and Pizey, of Baldwin-street, Bristol, were the architects, and Mr. C. Williams, of Swindon, was the contractor.

The death is announced of Mr. James Brashier, who carried on the business of a builder for about 50 years at 236, Brixton-road, S.W., in which he was assisted by two sons, both of whom predeceased him. Mr. Brashier retired from active business some twelve years ago, and has since resided at 17, Burton-road, where he died on Tuesday at the age of 81 years.

A general assembly of the Royal Scottish Academy was held on Friday for the election of an Academician in room of the late Mr. Otto Leyde. There were several nominations, but the only names that received strong support were those of Messrs. F. Ogilvy Reid and Alexander Roche. On a final vote Mr. Reid, who has been an associate since 1888, and has lately abandoned Scottish domestic incidents for landscape work, was elected by twenty-one to seventeen votes.

The London School Board have decided to fill one of the lunettes in their board room on the Embankment with the armorial bearings of the Marquis of Londonderry to commemorate his chairmanship. The work will be executed by Messrs. Powell, of Whitefriars.

Mr. Edward Duncan Stoney, only son of the late Mr. F. G. M. Stoney, of the firm of Ransomes and Rapier, Limited, Waterside Works, Ipswich, died in this town at the age of 29, on Tuesday week, leaving a widow and three children. Mr. Stoney superintended for the firm the erection of the sluices on the Manchester Ship Canal and those on the Thames at Richmond. He won the prize of 100 guineas for a design for the improvement of the River Severn at Bridgwater, and, had he lived, would have superintended the erection of sluices on the Clyde, for which Messrs. Ransomes and Rapier have the contract. For a year past Mr. Stoney had been in failing health.

The monthly memorandum of the Labour Department states that employment at the end of January was not so good as it was a year ago. The percentage of unemployed in the trade unions making returns was 4.96 per cent. (excluding persons directly on strike or locked out), compared with 5.34 per cent. at the end of December, and with 3.3 per cent. at the end of January, 1897. Employment in the building trades has improved, and continues good. The percentage of unemployed union members was 2.0 at the end of January, compared with 2.4 at the end of January last year. The furnishing trades are scarcely so active, though up to the average for the season. The percentage of unemployed union members at the end of January was 5.1, the same as in January, 1897.

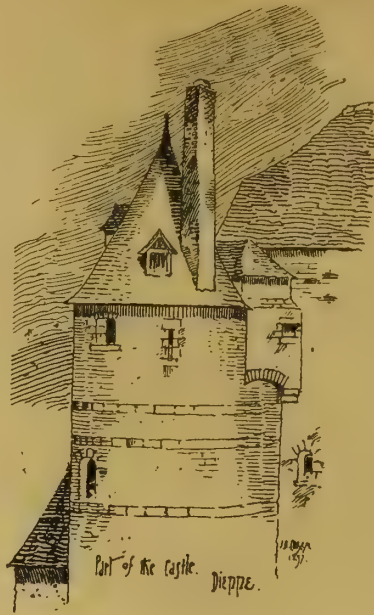

SKETCHES FROM DIEPPE

BY J. H. CORAM



Cross  
St Jacques  
Dieppe.

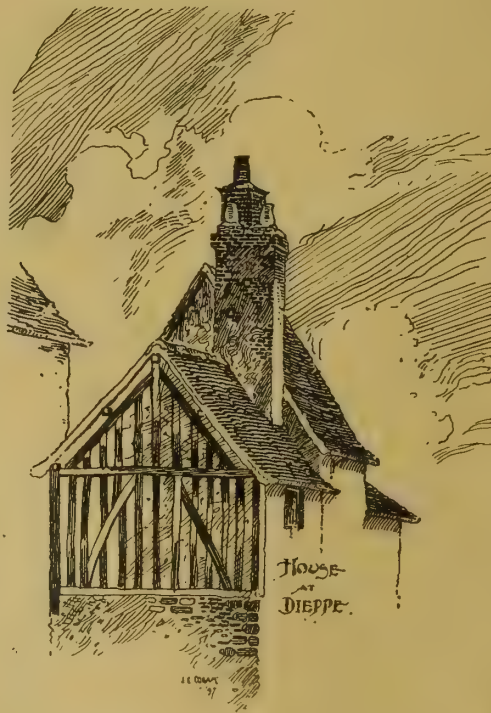

House  
at  
Dieppe.



Cross  
St Remi  
Dieppe.













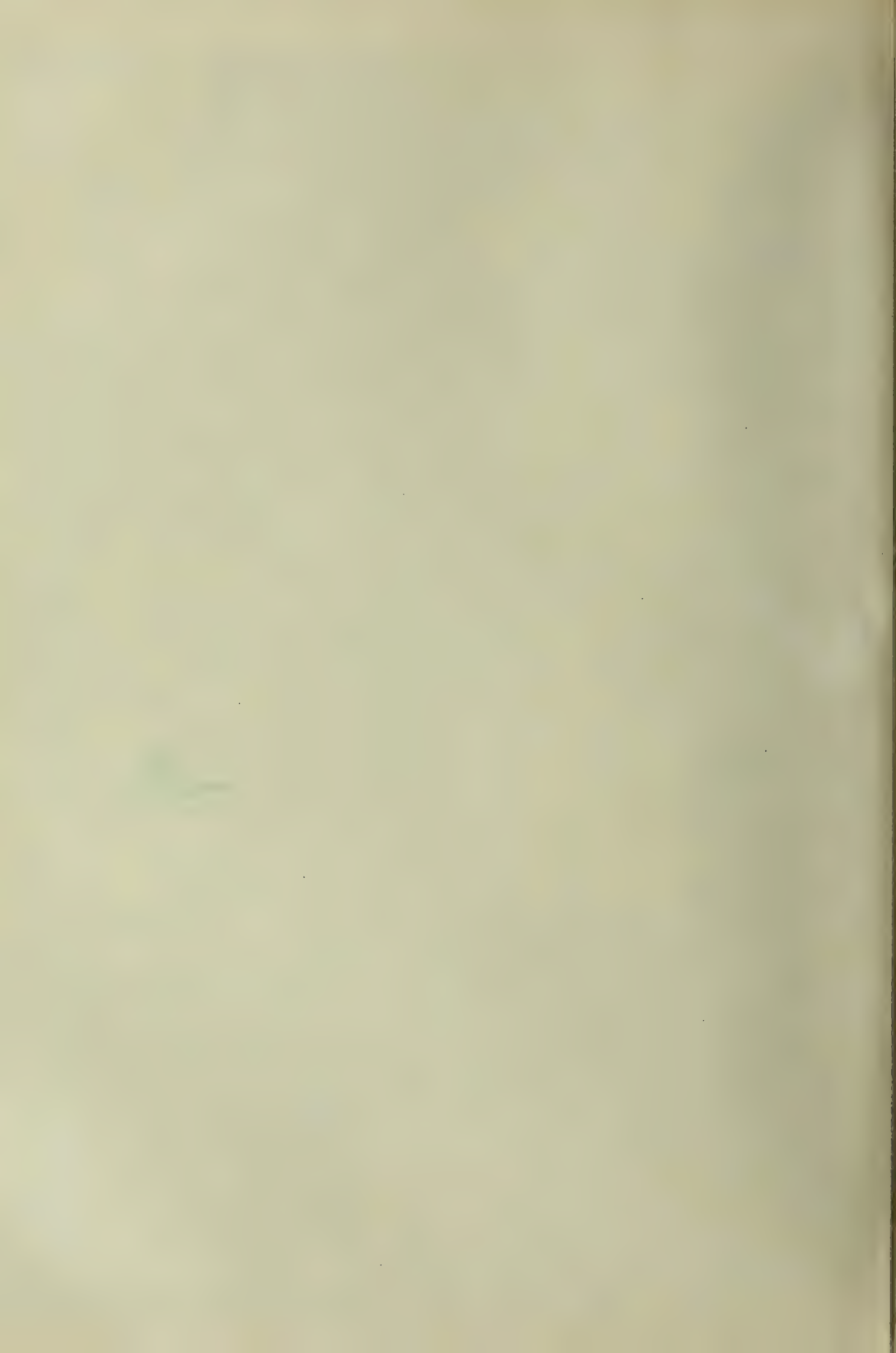

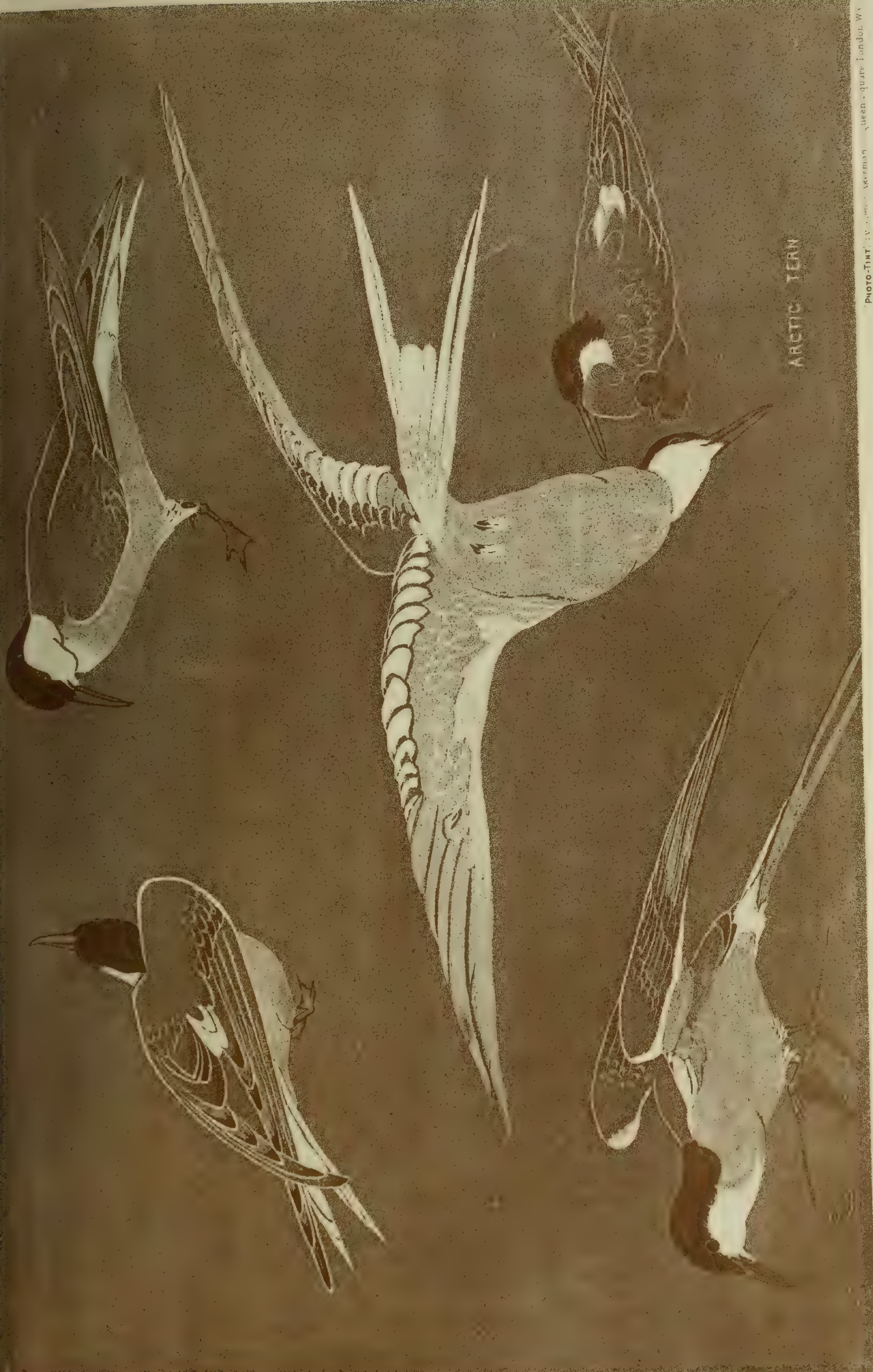

ARCTIC TERN

PHOTO-TINT. V. L. ... Vermin ... Queen ... Lundus ... W.

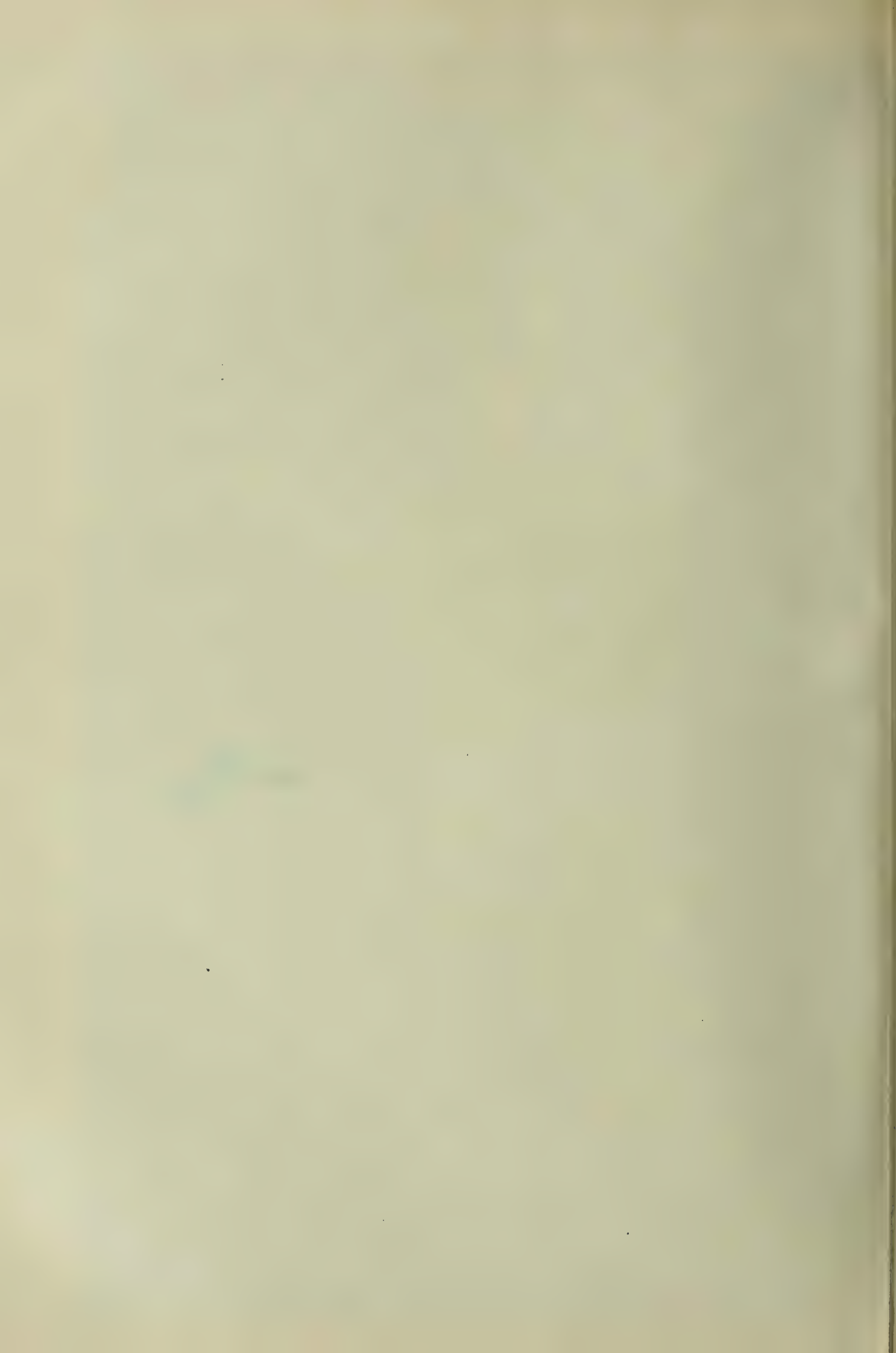





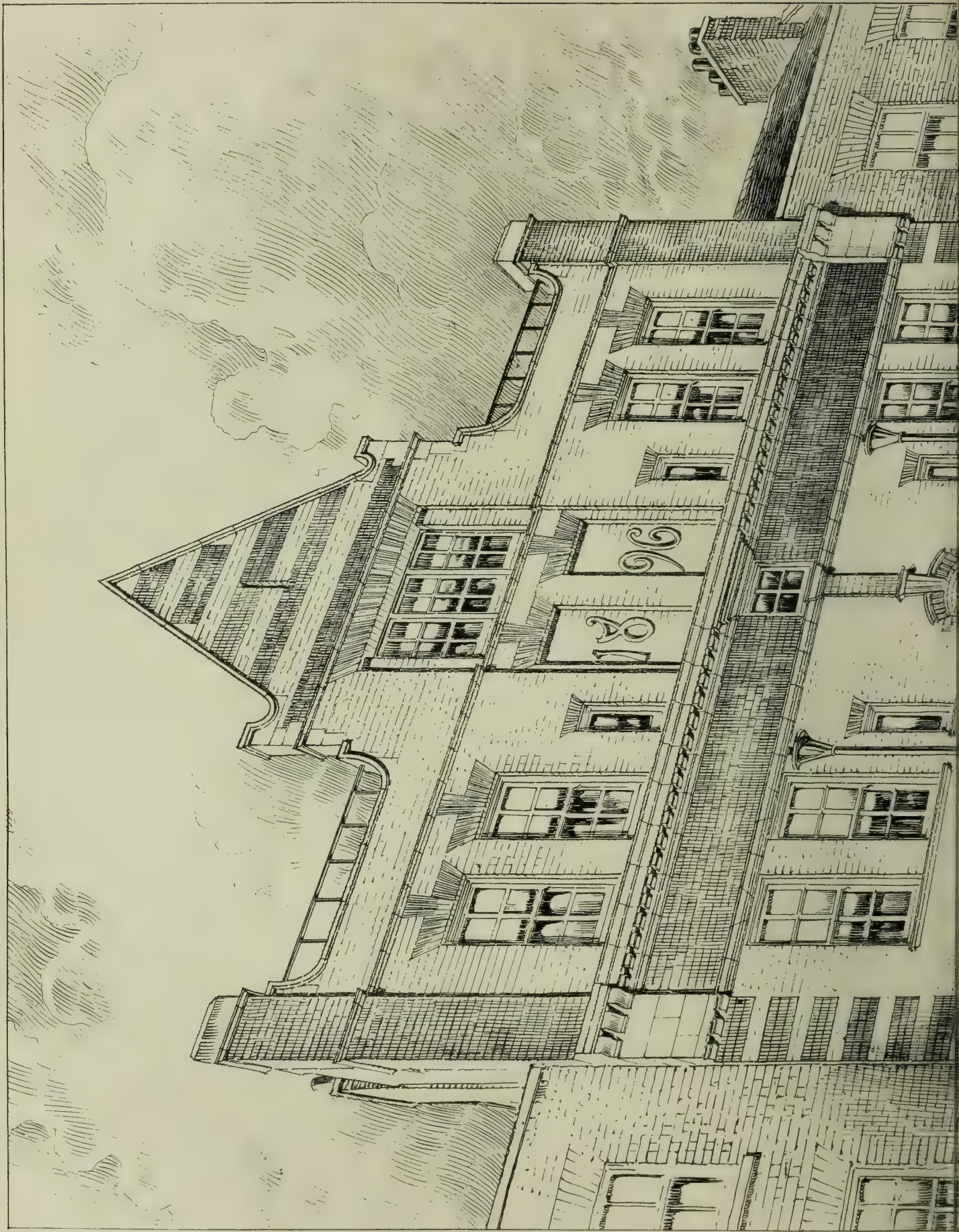

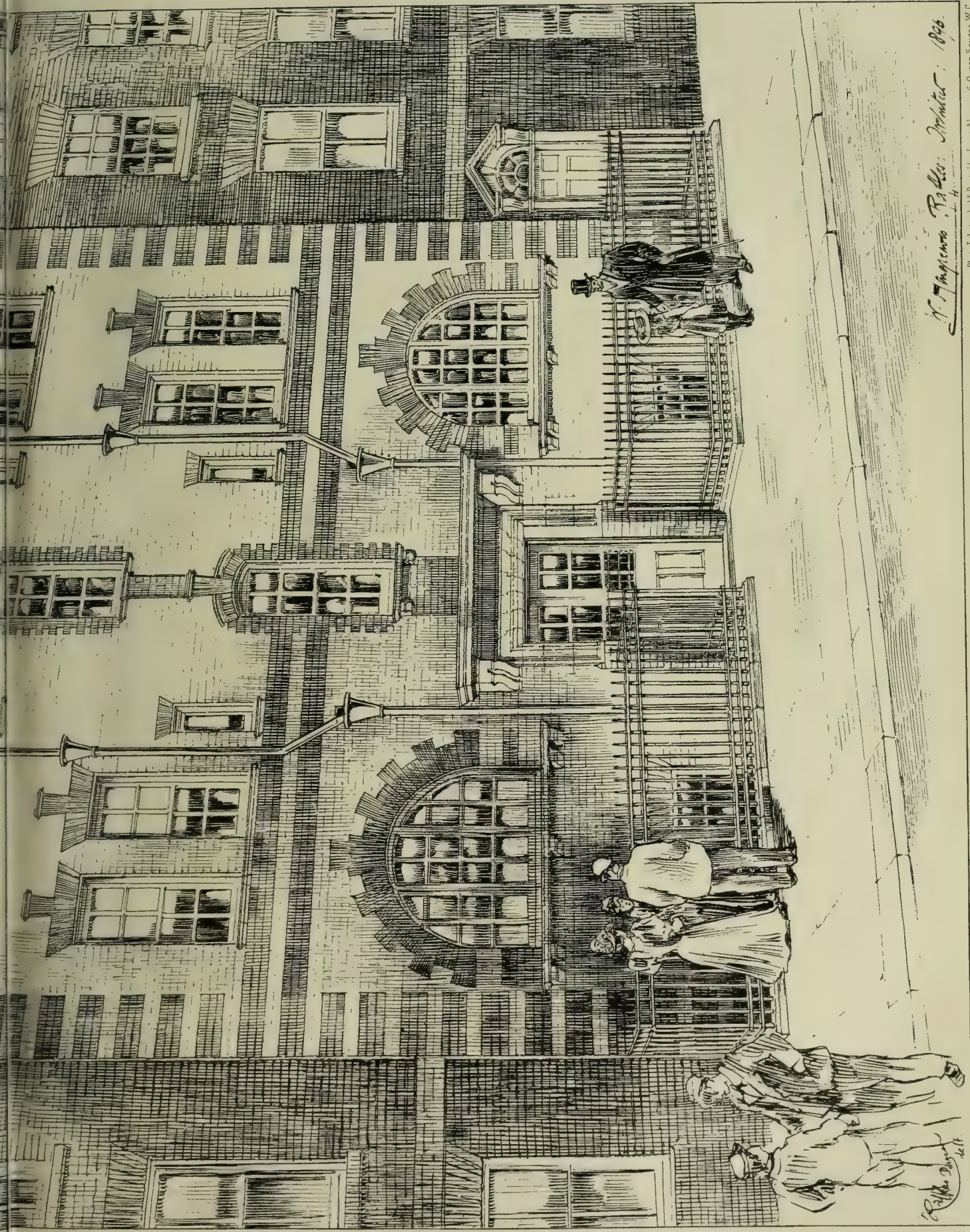

*N. J. M. P. Raffles: Architect: 1866.*

Photo Lithographed & Printed by James Alkerman, 6 Queen Square, W.C.

PREMISES · GOSFIELD · S.T.W. · WHARGREAVES RAFFLES ARCHT

*Raffles Design 1866*

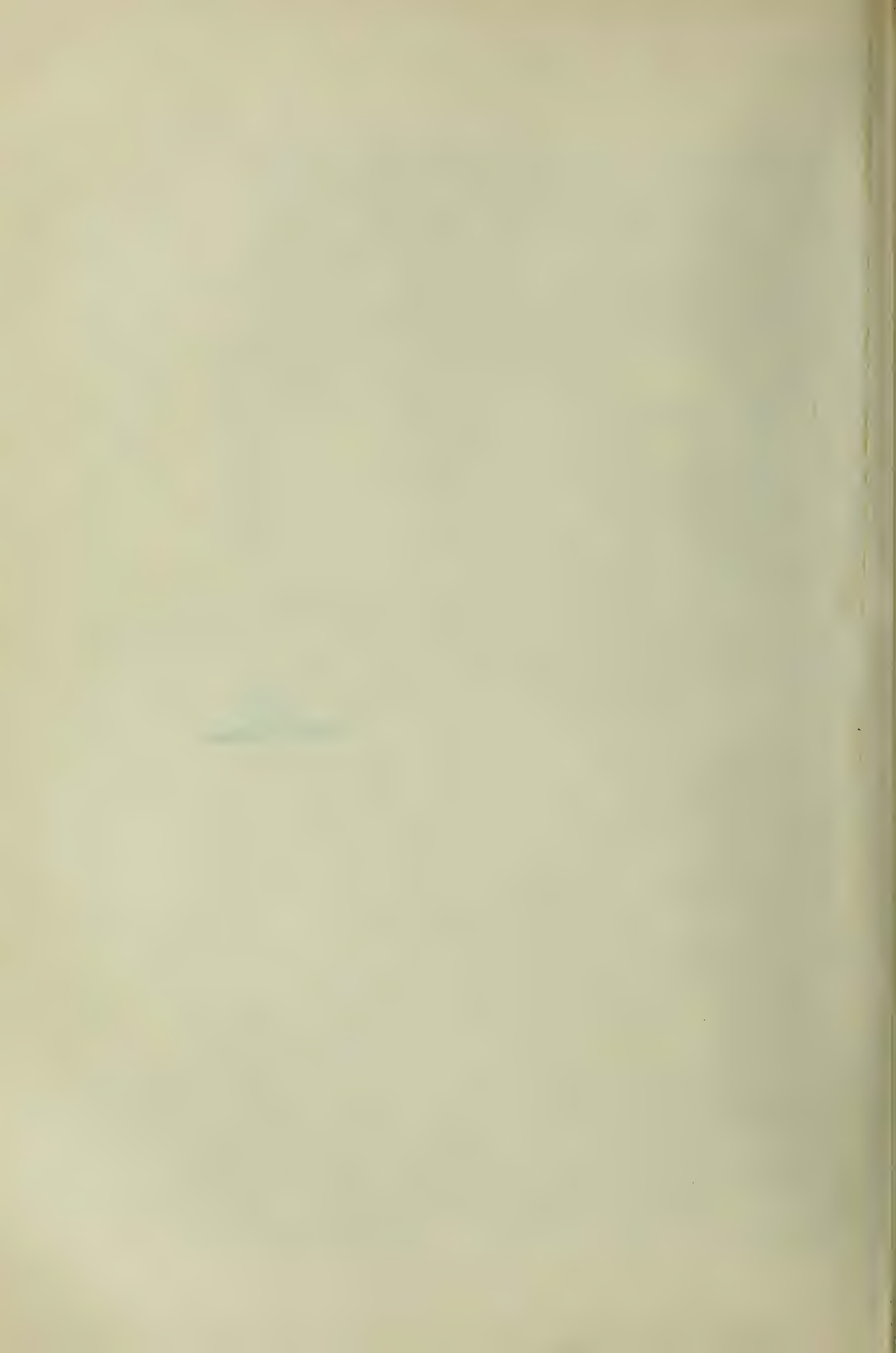



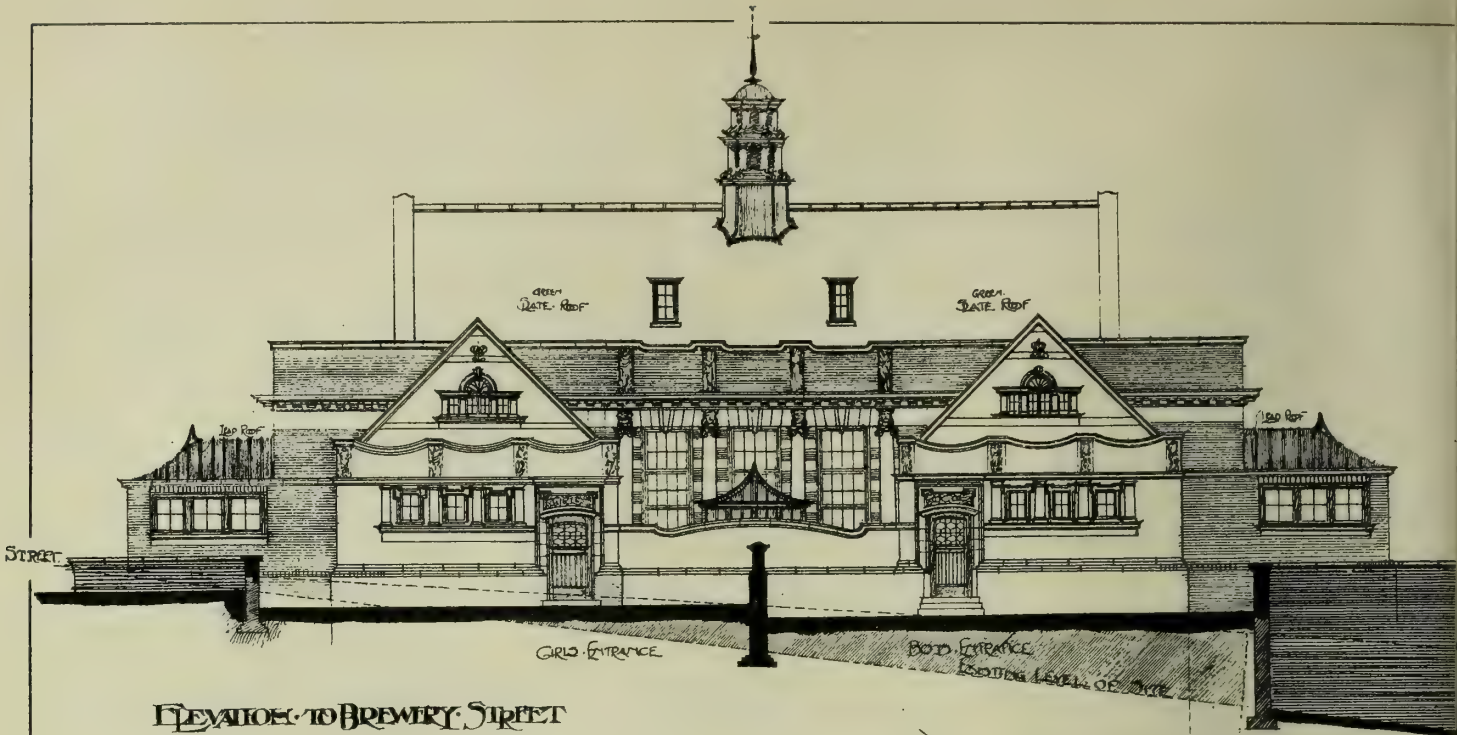

ELEVATION TO BREWERY STREET

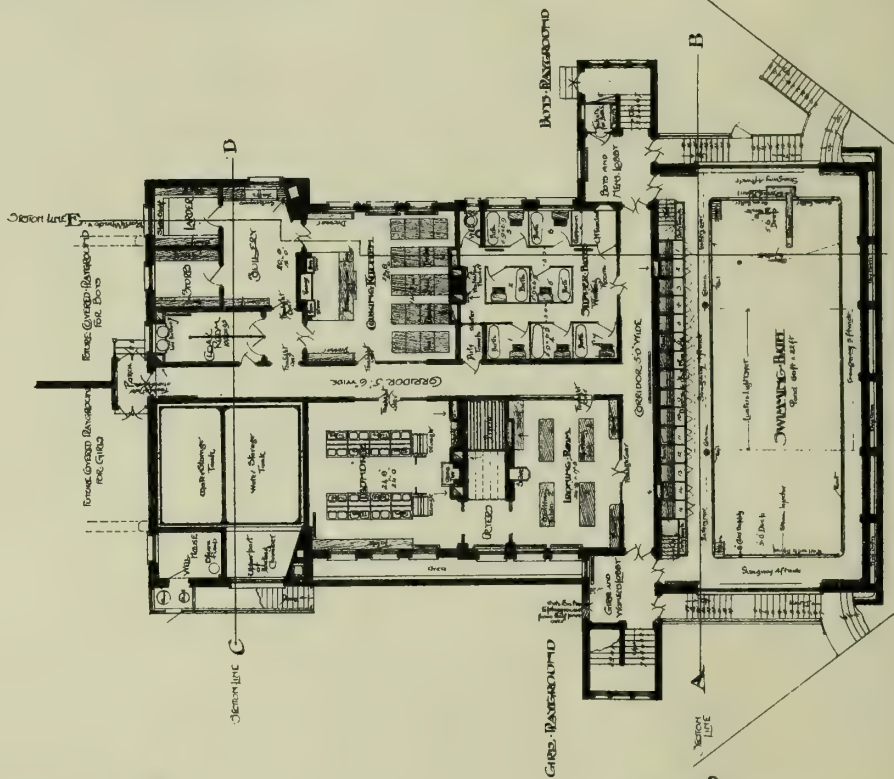

CHESTER

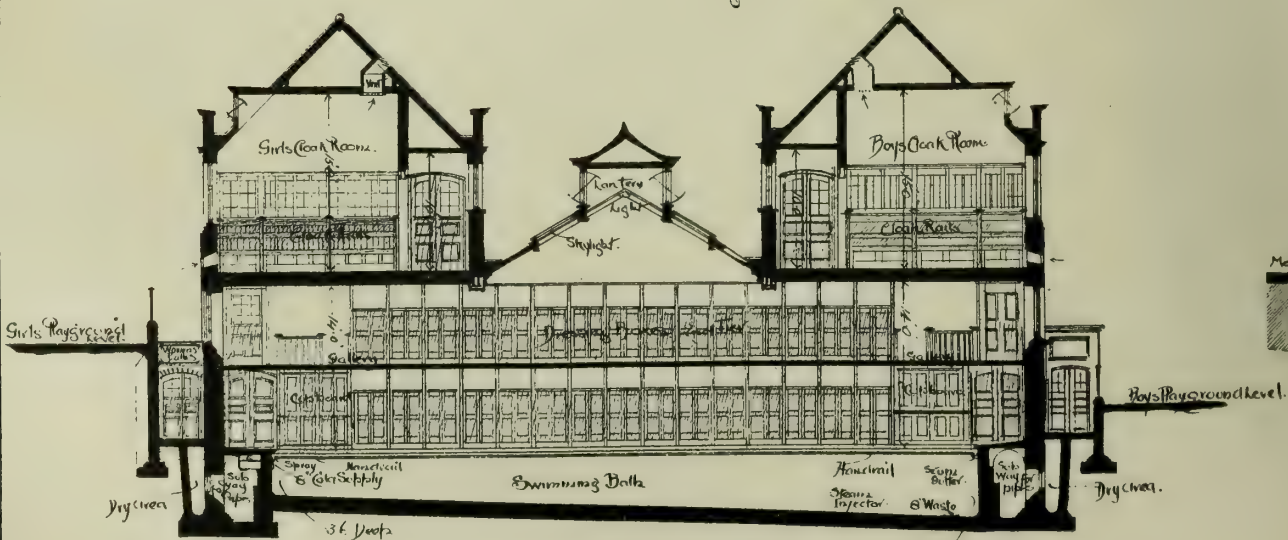

SECTION OF LIFE A-B

18th LEVEL  
BROMERY STREET

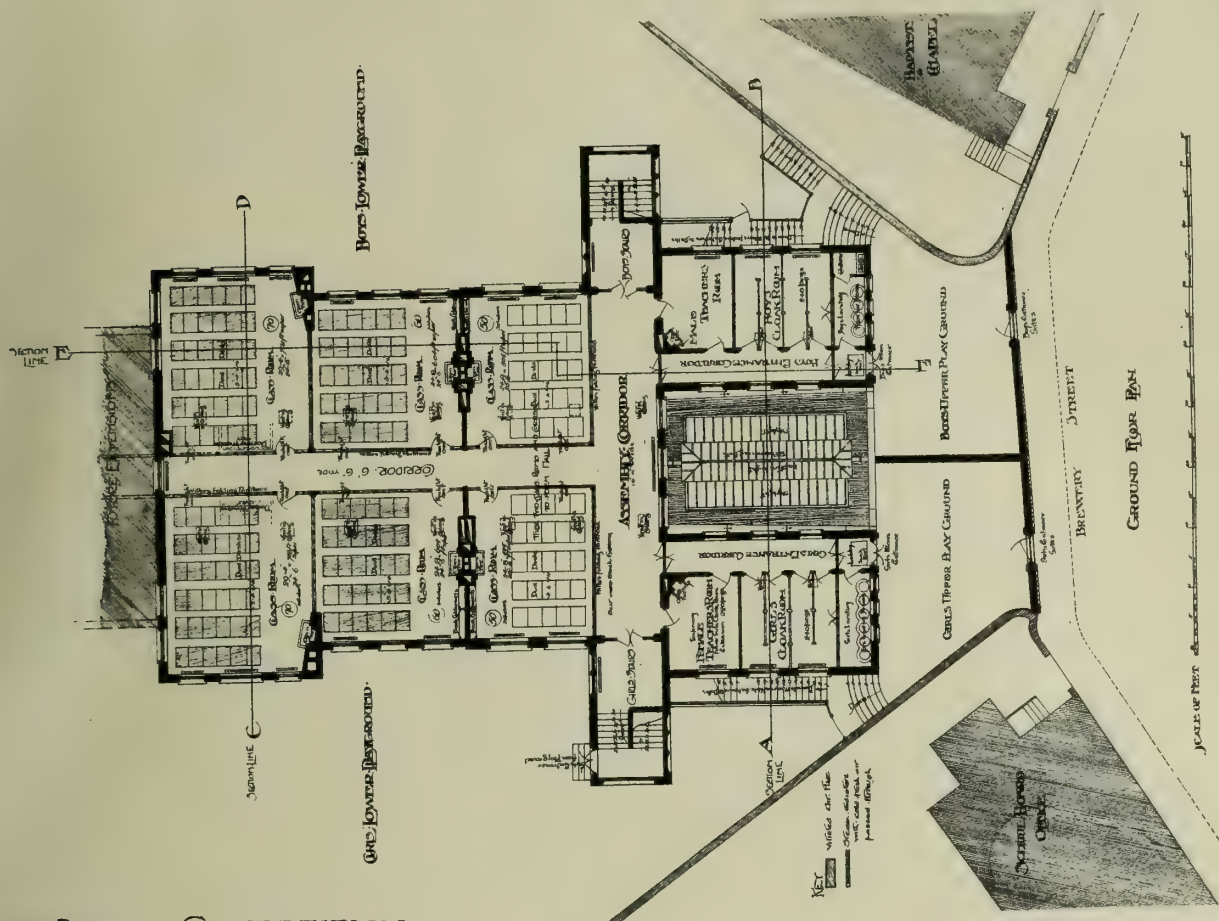

SCHOOLS & BATHS COMPETITION

SECOND PREMIAED DESIGN BY MESS<sup>RS</sup> HALL, COOPER & DAVIS ARCH<sup>T</sup>S

SIDE ELEVATION TO BOYS PLAYGROUND

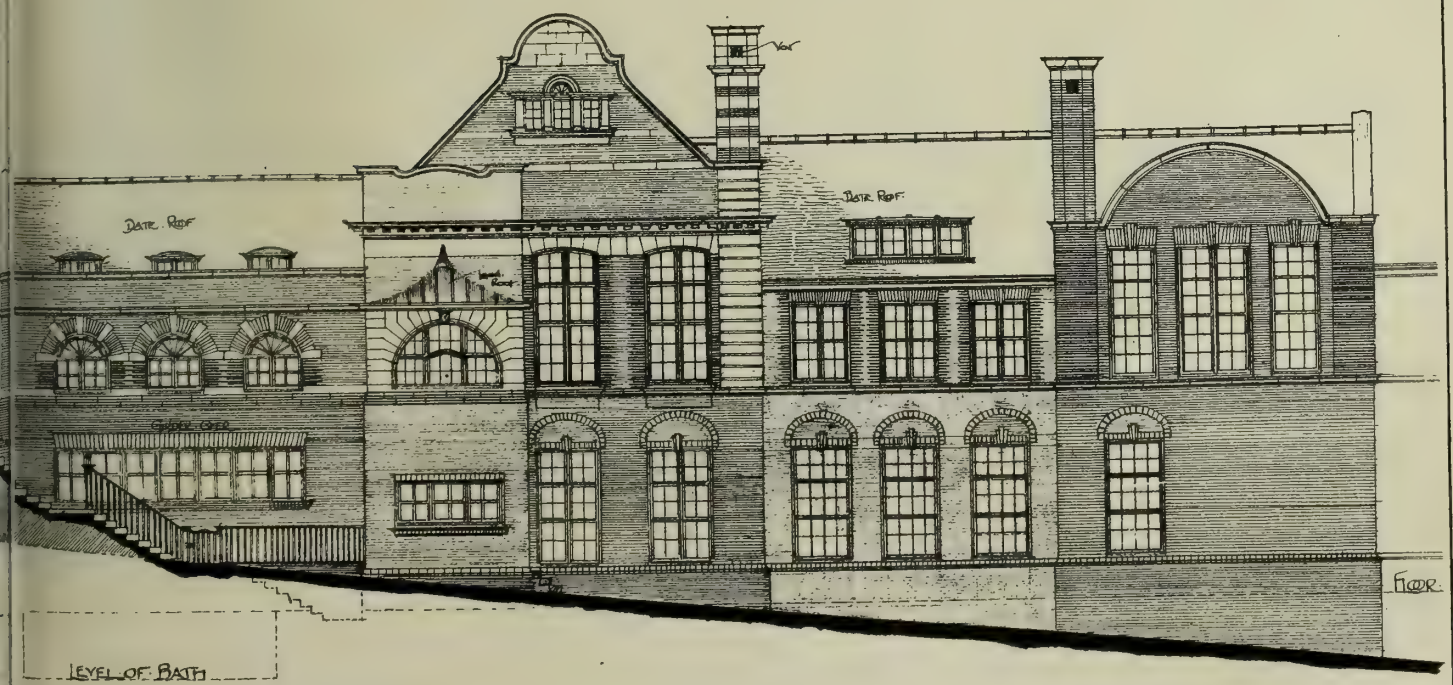

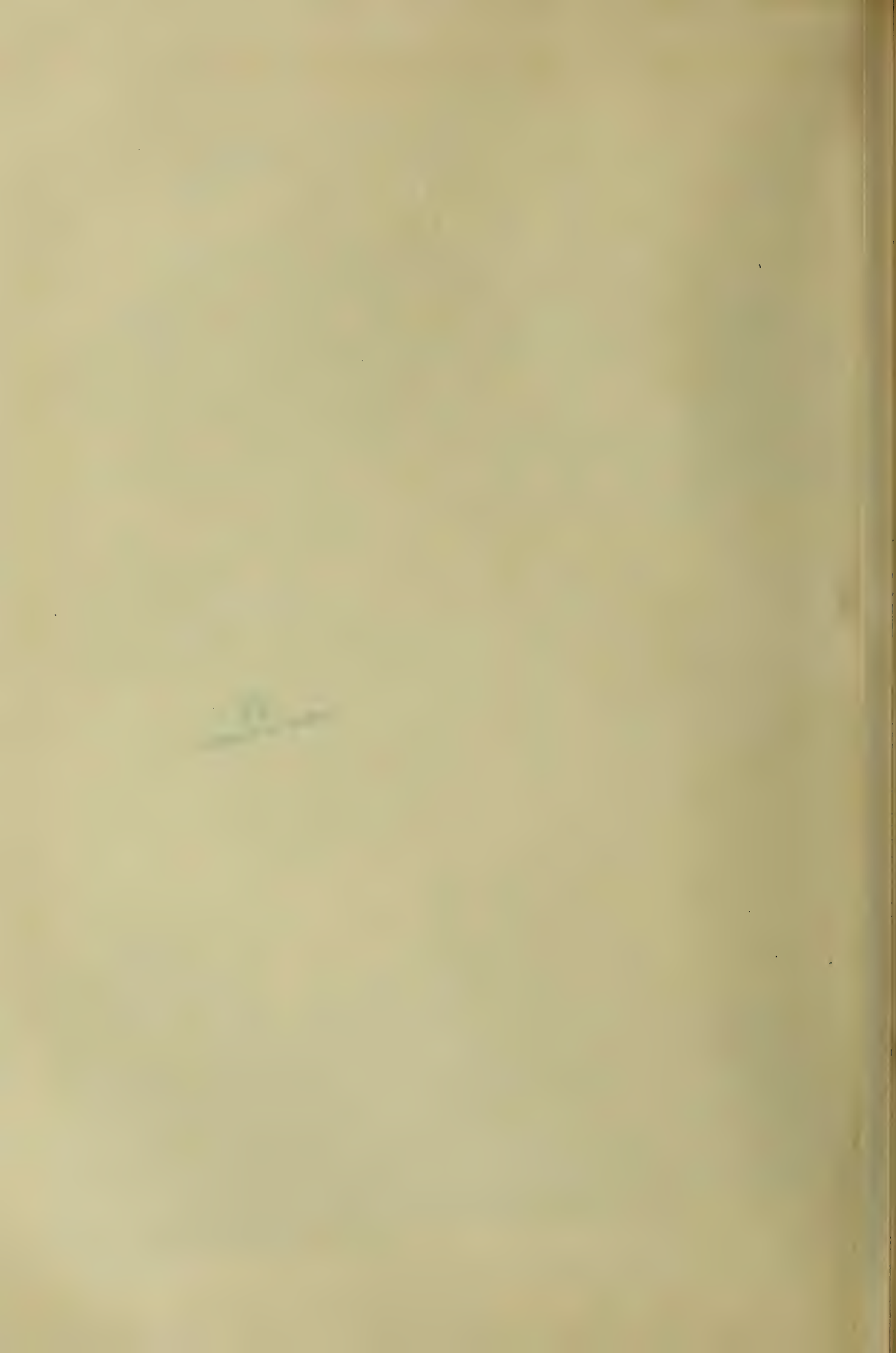



TWO SOMERSETSHIRE PULPITS

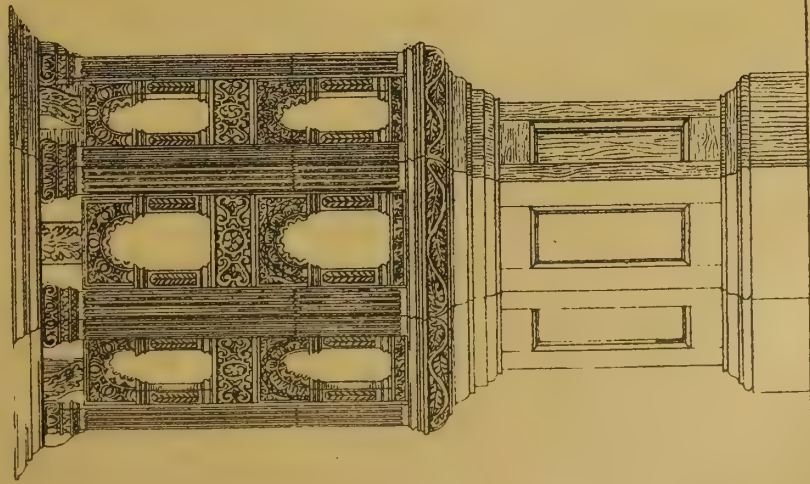

SOUTH BRENT

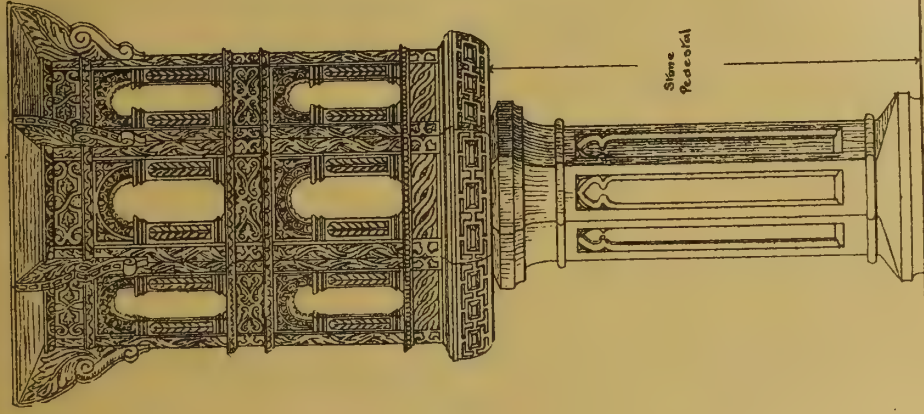

EAST BRENT

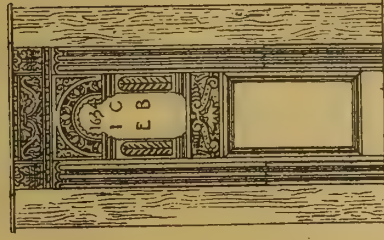

PANEL ON INSIDE



## TO CORRESPONDENTS.

[We do not hold ourselves responsible for the opinions of our correspondents. All communications should be drawn up as briefly as possible, as there are many claimants upon the space allotted to correspondents.]

It is particularly requested that all drawings and all communications respecting illustrations or literary matter should be addressed to the EDITOR of the BUILDING NEWS, 332, Strand, W.C., and not to members of the staff by name. Delay is not unfrequently otherwise caused. All drawings and other communications are sent at contributors' risks, and the Editor will not undertake to pay for, or be liable for, unsought contributions.

Cheques and Post-office Orders to be made payable to THE STRAND NEWSPAPER COMPANY, LIMITED.

## TERMS OF SUBSCRIPTION.

One Pound per annum (post free) to any part of the United Kingdom; for Canada, Nova Scotia, and the United States, £1 6s. 0d. (or 6dols. 30c. gold). To France or Belgium, £1 6s. 0d. (or 33fr. 30c.). To India, £1 6s. 0d. To any of the Australian Colonies or New Zealand, to the Cape, the West Indies, or Natal, £1 6s. 0d.

## ADVERTISEMENT CHARGES.

The charge for Competition and Contract Advertisements, Public Companies, and all official advertisements is 1s. per line of Eight words, the first line counting as two, the minimum charge being 6s. for four lines.

The charge for Auctions, Land Sales, and Miscellaneous and Trade Advertisements (except Situation advertisements) is 6d. per line of Eight words (the first line counting as two), the minimum charge being 4s. 6d. for 40 words. Special terms for series of more than six insertions can be ascertained on application to the Publisher.

Front-page Advertisements 2s. per line, and Paragraph Advertisements 1s. per line. No Front-page or Paragraph Advertisement inserted for less than 5s.

Advertisements for the current week must reach the office not later than 3 p.m. on Thursday. Front-page Advertisements and alterations in serial advertisements must reach the office by Tuesday morning to secure insertion.

## SITUATIONS.

The charge for advertisements for "Situations Vacant" or "Situations Wanted" is ONE SHILLING FOR TWENTY-FOUR WORDS, and Sixpence for every eight words after. All Situation Advertisements must be prepaid.

## NOTICE.

Bound copies of Vol. LXXII. are now ready, and should be ordered early (price Twelve Shillings each), as only a limited number are done up. A few bound volumes of Vols. XXXIX., XL., XLI., XLII., XLIII., XLIV., XLV., XLVI., XLVII., XLVIII., XLIX., L., L.I., L.II., L.III., L.IV., L.V., L.VI., L.VII., L.VIII., L.IX., L.X., L.XI., L.XII. may still be had, price Twelve Shillings; all the other bound volumes are out of print. Most of the back numbers of former volumes are, however, to be had singly. Subscribers requiring any back numbers to complete volume just ended should order at once, as many of them soon run out of print.

C. A. IRWIN. (We never trouble ourselves—nor need you—about what such people say.)

RECEIVED.—R. C. (Birmingham).—T. G. R.—T. W. Co.—D. E. U.—F. N. H.—K. P. and Son.

## "BUILDING NEWS" DESIGNING CLUB.

DRAWINGS RECEIVED.—"Centaur," "Cobden," "Eric," "Bantam," "Pick-me-Up," "Glaour," "Spark," "Byd," "Stanley," "Derige," "Microbe," "Gossip," "Gib," "Dachs," "Checkmate," "R. W. P.," "Tit-bits," "Stone," "Pantile," "Thrums," "Strax," "Oak," "Hubert," "William the Englishman," "E. G.," "Bernard," "Petticoats," "Chess."

## Correspondence.

## THE ROYAL GOLD MEDAL AT THE INSTITUTE.

To the Editor of the BUILDING NEWS.

SIR,—Mr. Wm. Woodward generally inspires useful work by his criticism of the Institute, and, though personally I cannot approve of his methods, it is evident that Mr. Woodward not infrequently imparts some life to the otherwise uninteresting proceedings which present so little attraction to the profession at Conduit-street. The dignified protest made by Mr. Woodward at the last meeting of the Institute against the nomination of Mr. George Aitchison as the recipient of the Royal Gold Medal, it must be confessed, fell very flat, and the reason for its failure was due to the fact that the technical objection thus brought forward really avoided the real merits of the case.

My contention is that it does not matter two straws whether the Gold Medallist happens to be the President of the Institute or not, provided he be the best candidate which the profession affords; but I think it is undesirable that the President should be chosen for the honour, provided there is an architect worthy of recognition by this

signal distinction of the Gold Medal, and speaking generally, it would be wiser and more disinterested to select such a one from outside the Council of the Institute. As it is, the Council at Conduit-street has become somewhat a snuggery, and the plums available are retained for home consumption—witness the appointment as referees originating at Conduit-street for competitions.

But, to return to the Gold Medal. To an obscure individual like myself, it does seem unfortunate that such masters of the art of architecture as Mr. G. F. Bodley, A.R.A., Mr. John F. Bentley, Mr. Hubert J. Austin, Mr. Basil Champneys, Mr. John Douglas, Dr. Rowand Anderson, or Mr. T. G. Jackson, R.A., should be passed over and ignored. Their executed works afford the justification for the mention of their names. What can Professor Aitchison show among his buildings and designs to compare for one moment to the productions of either of these architects? Personally, I have always found the professor a most cultivated and accomplished man, and my acquaintance with his work extends back to the days when his office was in Muscovy-court, and his practice was associated with warehouses. Mr. Aston Webb's grain silo at Greenwich, as a sample of warehouse design, is worth all that Mr. Aitchison has done in that way put together, and yet Mr. Aston Webb has not received the Gold Medal.

I do not deny the learning displayed by the President in his Academy lectures, and, against all comers, I yield to none in my recognition of his good-heartedness and genial *bonhomie*, but I fail to see the surpassing beauty or architectural merit in his work at all adequate to the occasion. In questions of taste in design few probably will agree; but the Professor, for one thing, has made a point of advocating the architectural use of iron. How has he himself shown the way to its application? Turn to the much-belauded house of the late Lord Leighton. One of the last additions made by Mr. Aitchison to that building was an extension of the studio on the first floor. This is carried by iron columns, which support the brick walls above. The columns themselves are needlessly big for the work they have to do; their scantlings, in fact, are in excess of structural requirements, so that the real difficulty of artistically treating the economical use of iron is avoided. But that which strikes me as most incongruous in this piece of the Professor's design is the use of horizontal coursed brick beams which come over the columns. There must be some secret girder, and one wonders where the injunction "Design with beauty and build with truth" comes in. I do not think any such a specimen of queer work can be found among the buildings or designs of any of the men I have been bold enough to mention. Of Mr. Aitchison's decorative designs I will say nothing, though I admit they never interested me very keenly beyond the fact that on some occasions, as with the boys and dolphin frieze in Lord Ilchester's house at the West-end, painted by Mr. W. E. F. Britten, if I remember rightly, the Professor has evinced good judgment in his choice of skilful fellow-workers. His ability in the general scheme of his decorations, as at the Goldsmiths' Hall, I do not for a moment wish to obscure. Honour to whom honour, and let justice be done. Excellent it may be for the Council of the Institute to elevate their President, for he has lately been made R.A.; but I for one consider it would have been more in accordance with real merit if the Institute and the Academy, too, had sought out Mr. G. F. Bodley, who, because he is a quiet worker, is unjustifiably overlooked. His buildings and designs justify this assertion. I know all the men I have named, but none of them are cognisant of this letter. Surely, it expresses what many must feel, even though my boldness in thus putting the case may offend the office-holders.—I am, &c.,

AN ART WORKER.

## QUANTITIES AND TENDERS.

SIR,—The correspondence in your columns on the above is one of great interest to all architects, and especially in the provinces where nearly all architects prepare, or have prepared, quantities in their own offices. There are, I think, two questions that ought to be decided before an architect prepares his own quantities, for perhaps the council of the Builders' Institute know by experience the incapability of many architects to prepare a proper set of quantities—that is, if London architects' quantities are, as a rule, no

more complete than many that are issued from a provincial office (though I must say my own London experience in this respect is decidedly different to the provincial). (1) Is the architect capable of preparing the quantities himself? (2) Is his practice too large to allow him to give personal superintendence to same, or does he leave them entirely to an assistant (in many cases quite unequal to the task)? If either of these objections are present, I say by all means an independent surveyor ought to be engaged; but if an architect is capable, and has time to prepare his own quantities, I say that no one else is so likely to include all his ideas and minor details necessary to complete his design as he himself is; it also assists him and saves time and trouble when detailing, and decidedly gives him a better grasp of his own work, and enables him at once, when superintending the works, to say this or that is, or is not, included, and extras and disputes would in many cases be avoided. But the provincial architect's quantities in most cases are very incomplete, and, on the other hand, many builders are as equally unprepared to price out properly a complete set of quantities when given. How seldom do we find such items as fair ends or jamb seats given on stone window sills, or mitres to skirting! Is this not unfair? The same amount of sills or skirtings in one job might have four times or more seats or mitres, as the case may be, as another job, even of equal size, all of which are time and money. A short while ago I had a set of quantities handed me for a fair-size work, and my great surprise was that any builder could be found to submit a tender on them. The items were such as these:—"No. window sashes, 7ft. by 3ft. all complete, glazed with of sheet glass. No. 1½ in. four-panel doors, with linings and 3 in. architraves," and so on from beginning to end. No wonder that a dispute arose at the end, which necessitated my measuring almost everything on the works. As the Institute of Builders refuse to give reasons to Mr. Williams for their objection to architect's quantities, it can well be ignored by all who are qualified to send out a properly-prepared set of quantities.—I am, &c.,

WILLIAM R. GREAVE, A.R.I.B.A.

18, Low Pavement, Nottingham.

## CHIPS.

Messrs. Higgs and Hill ask us to state that their firm will be, for family reasons, converted into a private limited company, and that the business will be under the same management as hitherto. No part of the share capital will be offered to the public.

A well-attended meeting of the newly-formed Leamington Master Builders' Association was held on Saturday evening, Mr. F. W. Smith presiding. Mr. Burgess was unanimously elected secretary, and a committee was appointed to draw up rules, &c.

The light railway between Selby and Cawood, via Wistow, was opened on Wednesday. It is a single line of ordinary gauge five miles in length, and passes through level agricultural country. The contract was carried out by Messrs. Whitaker Brothers, of Horsford, at about £25,000.

The office of diocesan surveyor under the Ecclesiastical Dilapidations Act for that part of the diocese of Worcester which is within the county of Warwick is vacant by the resignation of Mr. J. Willmot.

A carved prayer-desk has recently been placed before the chair used by the bishop for ordinations, &c., in the choir of Salisbury Cathedral. The desk, of Italian walnut, has traecoid ends surmounted with conventional foliage, and the group in front depicts Moses with his hands stayed up by Aaron and Hur (Ex. xvii. 12). The work was executed from the designs of Mr. E. Dram Webb, of Salisbury.

In the House of Lords on Monday Earl Stanhope will ask whether, in view of the decay or depreciation of the stone on the south side of the new wall of Westminster Hall, the Government will take early steps to repair or silicate the same.

An important communication came before the corporation of Dover on Wednesday in relation to the National Harbour works there, the contractors asking for extensive facilities at the east and west end of the town. The contractors desire to be allowed to take over the East Cliff Jetty, which they will extend 1,000ft. into the bay. They also propose to construct viaducts east and west of the town—that to east at a cost of £75,000, running under the cliff in the direction of St. Margaret's Bay. Arrangements are being made to start the harbour works next month.

# Intercommunication.

## QUESTIONS.

[11902].—**Model Specifications.**—Will one of your correspondents be good enough to tell me whether there are such publications as model forms of building specifications applicable to ordinary domestic architecture—dwelling houses, shops, and the like—both for new erections and repairs? What also is the best book on quantity surveying for a beginner?—STUDENT.

## REPLIES.

[11897].—**Load on Girder.**—Taking moments round

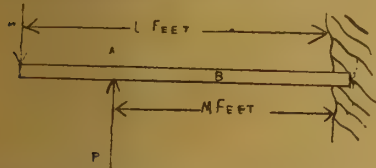

the point at which the girder B enters the wall, we have, if P tons be the upward pressure exerted by the girder A,

$$P \times M = W \times L.$$

Therefore—
$$P = \frac{W \times L}{M} \text{ tons.}$$

In the present instance  $W = 12$  tons,  $L = 14'$ , and  $M = 10'$ . Hence—

$$P = \frac{12 \times 14}{10} \text{ tons} = 16\frac{8}{10} \text{ tons,}$$

which must, therefore, be the amount of the pressure caused by the weight W.—J. C. PALMER.

[11893].—**Artificial Stone.**—The stone to which you refer is called "Owen Stone," which, after a careful examination, I am convinced can be used with advantage in place of Portland. I believe the offices of the company are at 28, Basinghall-street, where, I am sure, further information will be given.—F. W. S.

[11897].—**Penalties for Delay—Liquidated Damages.**—Much depends upon the wording of building agreement. I have lately recovered damages for delay. If "Nemo" would care to send me copy of his agreement, I would advise him. Perhaps the case of "Dodd v. Churton," *vide* BUILDING NEWS, March 26, 1897, p. 470, would help him.—J. H. H., The Bourne, Farnham.

[11897].—**Penalties for Delay—Liquidated Damages.**—Though penalties are not often indicated, it is no reason to assume that they are not sometimes enforced. It is usual to provide for the due performance of the work by fixing a sum to be paid on breach. As to recovery, the question depends on whether it is a penalty or liquidated damage. The first is conclusive on neither party, and the amount and damages suffered must be proved; liquidated damages bind both parties. It is a question of law really for the Court to decide whether the sum specified is a penalty or liquidated damages. "Ranger v. Great Western Railway," "Fletcher v. Dyche," "Crux v. Aldred" are cases. In one case the plaintiff, a builder, contracted to make repairs, &c., to a house within a certain time "subject to a penalty of £20 per week that any of the works remained unfinished" after the stipulated time. It was held that the sum of £20 per week was in the nature of liquidated damages, and could be deducted by the defendant without proving the loss he had actually sustained by the delay. Consult cases also of "Law v. Redditch Local Board," "Sainter v. Ferguson"—LEX.

[11898].—**Paint for Oak Joinery Work.**—Under the circumstances, the oak should be either oiled or wax-polished. The first process consists in sponging the wood with linseed oil, and then with a wet flannel, or woollen rubber (no oil in it); rub the wood from end to end in straight rubs until it shines or a gloss appears. To wax-polish, prepare the wax as follows:—Dissolve 6oz. of pearlsh in 1 quart of hot water, and add 4oz. of white wax. Let the mixture simmer for half an hour, then remove it from the fire and set aside to cool. When cold, the wax will float on top; skim this off, and with a little hot water make it into a paste, and rub the wood with this paste, using woollen rubbers, until an egg-shell gloss appears.—H. C. S.

[11899].—**Damp-proof Course.**—If possible, clear a trench 18in. or 24in. from wall, concrete bottom, and build up brick lining in left ground, arching over at top, with air-bricks here and there. If lined inside with best asphalt so much the better. If it were possible to get Taylor's earthenware damp-course inserted in the wall of house above soil, it could only be done by piecemeal.—REGENT'S PARK.

[11899, 11900, and 11901].—**Waterproofing Bricks, Damp Walls, and Damp Course.**—Saturate the bricks or rough-cast wall with several applications of the boiled oil, or else linseed oil in which glue has been dissolved. This latter compound is prepared thus: Soak the glue for 12 hours until soft; then pour away surplus water, and dissolve the soft glue in linseed oil in a glue-pot (or steam-jacketed boiler). Another process which may prove satisfactory is to saturate the walls, &c., with a strong solution of gelatine in water, and before this dries on the wall, let a second person apply a solution of bichromate of potash. The result will be, if the wall be an exterior one and exposed to light at all, a coat of waterproofing gelatine is fixed in the pores of the brick or plaster. Still another waterproofing may be tried as follows. Make a strong solution of a good tallow soap in boiling water. Brush this well on the wall or plaster, and before it dries let a second person lay on a solution either of green copperas (ferrous sulphate) or of bluestone (sulphate of copper). This solution will be decomposed by the soap solution in the pores of the brick or plaster, and a sebate of iron or of copper be produced in the pores. The sebrates are not permeable to water. Another way of using such sebate is to mix a solution of a tallow soap, a solution of either the above salts, collect the flocculent

sebate that precipitates, and after draining this or drying off all moisture, dissolve it in hot turpentine and use the liquid on the walls as a varnish. If any of these processes are tried, perhaps a report of the result will be sent to the Editor for the benefit of the BUILDING NEWS readers in general.—H. C. S.

[11901].—**Damp Wall.**—Undoubtedly the best plan to prevent the wet penetrating is either to render the outside with Portland cement, or, this being objected to on account of its appearance, to cover the wall with ornamental tiling hung on battens. If, however, the outside must not be touched, another good plan is to batten the inner face of the wall, and finish with lath-and-plaster. The battens might be about 1½in. by 2in., plugged to the wall at intervals of 12in. to receive the laths. This method is not so good as the others, inasmuch as it still allows the brickwork to remain saturated with water, and simply prevents the wet appearing on the surface of plastering.—H. BUSBRIDGE.

[11899].—**Damp-Proof Course.**—One remedy is to insert in lengths perforated slabs of stoneware or, better, sheets of 4lb. lead; but this is a troublesome operation, requiring underpinning. A more easy course is to remove the damp and injured plastering inside, and to cement the wall. At the same time, it is probable the earth outside is above the damp-course. If it is, form a dry area. White's composition might be applied externally instead.—H. T.

[11901].—**Damp Wall.**—"P" had better batten his walls inside; it is the only remedy. Brick walls facing south-west are never impermeable to driving rains. I have known 14in. solid walls quite saturated; hollow walls are the only safe way of building. Have you tried Szerelmy's liquid on the outside? It has been found useful in many cases of this kind by stopping up the pores of the brick.—ARCHITECT.

## LEGAL INTELLIGENCE.

THE BUILDING OF A WORKHOUSE: T. DREW-BEAR, TOLPUIT, AND BROWN V. THE GUARDIANS OF ST. PANCRA'S UNION.—On Friday last Mr. Justice Ridley delivered judgment in the Court of Queen's Bench in this remarkable and protracted case. We reported the earlier phases of the inquiry in our issues of July 17 and 24, and November 20 and 27, 1896 (pp. 98, 133, 755, and 769, Vol. LXXI., and January 22 and 29, March 5, 12, and 19, 1897, pp. 149, 185, 365, 379, and 413, Vol. LXXII.), when it was originally heard at the Old Bankruptcy Court, Portugal-street, W.C., before Mr. Edward Ridley, Q.C. (as he then was), sitting as Official Referee; the appeal to the Divisional Court, which followed, in the BUILDING NEWS for April 16, 1897, Vol. LXXII., p. 579, when Justices Grantham and Wright set aside the Official Referee's decision against the guardians; and the decision of the Court of Appeal, consisting of the then Master of the Rolls (Lord Esher) and Lords Justices A. L. Smith and Chitty, which was reported in our issue for May 21, 1897, p. 737, reversed the judgment of the Court below, and upheld the Referee's decision, further remitting the case to be heard again by Mr. Ridley, who in the mean time had become the Hon. Sir Edward Ridley, one of the Judges of the Queen's Bench Division. That trial, which was confined to deciding the amount of such damages as could be proved to be the result of delay in giving possession of the site of the workhouse to the contractor, and of interference with the said contractor's work by sub-contractors, occupied the Court throughout the second week of January last, and is reported in our issues of Jan. 14 and 21 current volume, pp. 77-8 and 110. Mr. Reginald M. Bray, Q.C., and Mr. A. A. Hudson appeared for the plaintiffs, and Mr. English Harrison, Q.C., and Mr. William Moyes for the defendants, a singular feature of the case being that the junior counsel on either side were formerly in practice as architects. In giving judgment on Friday, Mr. Justice Ridley remarked that the case was one in which he had to assess the damage to which he might consider the plaintiffs were entitled to according to the judgment of the Court of Appeal. As he understood it, the judgment of the Court of Appeal laid down the rule that the plaintiffs were entitled to damages by reason of the contractor not having been allowed to get possession of the site in question at the proper time; but they were not entitled to claim anything in respect to damages that might result from the acts of the architect; it was not, therefore, a case in which it could be said that the whole of the contract was at an end, and the plaintiffs were entitled to recover on a *quantum meruit*, but the amount of damages to which the plaintiffs were entitled must be ascertained in respect to such injuries as resulted to the contractor not being granted by the guardians possession of the site of the proposed buildings. The evidence which had been called on the several heads of the damage was of a general character, the witnesses examined before him speaking on their experience as surveyors or builders, and giving their opinion as to the percentage a builder would find his outlay increased if he did not obtain full possession of the site. That class of evidence, he considered, appealed to anyone's common-sense, because if a contractor had four or five blocks of buildings to erect it was obvious in a moment that it was of the greatest consequence that the whole site should be clear, in order that the builder could map out his work, and so get it pressed forward that each part should help the other. If the contractor were compelled to build one portion at a time, the work became dis-

located, and the greater the number of buildings he had to erect the worse became this dislocation. That was the nature of the present case. It was indeed some time before he personally arrived at the conclusion that it was of so much importance in this case. No doubt the interference by the architect did involve delay to some extent; but he thought that the real cause of the mischief which upset the calculations of the contractor and the expectation of the guardians as to the completeness of the work was mainly due to the fact that possession was not given of the site. That was the way the contract was broken. On the other hand, it should not be forgotten that on the previous occasion it was the plaintiffs who contended for the most part during the inquiry that the architect was the person who had prevented the job being carried out, and certainly he did interfere more than usual in respect to materials brought on the site and to work done on the job. In the second inquiry as to the damages, the case was reversed, because the plaintiffs, who formerly contended that by reason of that interference the undertaking was prevented from being carried out, said, on this second inquiry, that the real cause of the delay was not getting possession of the site. The truth of it was that although there was undoubtedly some delay occasioned by the interference of the architect, common sense suggested that the real cause of the delay was the failure to give possession of the site. It was very unfortunate that this was not done. It was now necessary to deal with the different heads of damage put forward. He certainly did not intend to go through the entire history of the case afresh. He had considered the matter as well as he was able on the materials laid before him. The first head of damage claimed was in respect to the increased cost of the labour by reason of the delay in getting possession of the site. The witnesses called for the plaintiffs had calculated this at the large sum of £6,357. That amount was established by a strong body of evidence as the ratio or proportion which in the building trade would be attributed to the failure of getting possession of the site. On the defendants' part there was no evidence whatever of any account. There was, indeed, no contradiction of plaintiffs' witnesses, and nobody was called or put forward to say they were not to be credited. The position taken by the defendants was that it was not right according to the judgment of the Court of Appeal that this should be taken into consideration; but he thought it was. In dealing with such a case as the present, he thought he ought to be guided by the opinion of those who understood the trade. He believed it was within the decision of the Court of Appeal that he should assess the damages to the best of his ability on the materials put before him. The percentage given by Mr. J. T. Chappell and other witnesses was not contradicted. He did not mean to say he was prepared to accept it to its full extent. He thought that they had not perhaps given sufficient weight to the fact that in this case the architect did interfere, and that he certainly did prevent, to a great extent, the carrying out of the work. He must, therefore, take off a considerable margin in respect of such interference by the architect, and he must also consider whether the whole of the case put forward by the plaintiffs was exactly made out. He did not think that the claim of interference upon the roads by the traffic of the guardians was made out by the plaintiffs. What he had been able to arrive at on this head was that in lieu of the £6,357 claimed by the plaintiffs they were entitled to £4,000. Then there was the claim for the increased price paid for labour from and after September 1, 1893. That he had included in the sum of £4,000 already named, and he should add nothing under that head. In the same way as to the profit of 10 per cent., that also was included in the sum of £4,000. As to the claim for interference by sub-contractors, he thought, looking at the evidence given, that it was exaggerated, and that the sum of £250 was as much as the plaintiffs were entitled to in respect to that matter. Next, as to the claim arising from the increased price paid for materials on and after September 1, 1893, although somewhat in dispute, he considered that on the whole it had been shown that the prices of materials generally were raised a good deal then. He could not, however, estimate the loss under that head at as high a figure as the plaintiffs had done, but they certainly ought to be awarded £500 for such increase. Concerning the claim for establishment charges, he allowed another £1,250. The charges as to loss of profit and failure to get possession of the capital outstanding, he had put together and allowed the sum of £1,000 under those heads of claim. The total of all the sums he had named was therefore £7,000. Mr. Bray, Q.C., applied for costs, on the ground that the defendants had only paid into court the sum of £2,500. Mr. Justice Ridley: You are, I think, entitled to the costs of this hearing. The Court of Appeal has already dealt with the costs. Mr. English Harrison: Then, technically speaking, your Lordship's judgment will be for £4,500, in addition to the sum paid into Court? Mr. Justice Ridley: Yes. Mr. English Harrison: Will you allow me a stay of execution

for about three weeks to consider the effect of your Lordship's judgment? The money is absolutely safe. Mr. Bray demurred, asking whether they had had not enough of this case. The learned Judge said he thought so. He could not delay anybody's execution in this case. He did not wish to stop people from taking appeals; but had there not been enough litigation in this matter. Mr. English Harrison pressed his demand for a stay of execution for three weeks, remarking that his clients had to go through a process to get the money, and that he did not therefore think the request unreasonable under the circumstances. His Lordship granted stay of execution for a fortnight, adding that the plaintiffs would, of course, be entitled to the £2,500 paid into Court in part satisfaction of their judgment.

**CHARGE AGAINST A HASTINGS BUILDER**—At the Hastings police-court on Friday, Luke Lutner Langridge, builder, of Hollington, was brought up on remand charged with being a person in respect to whose estate a receiving order had been made, did unlawfully quit England, and take with him a certain sum, part of his property, above the amount of £20 in money, which ought by law to be divided among his creditors, contrary to the statute. Prisoner, who was arrested at Capetown, took with him in November two cheques—one for £275, drawn on a Mr. Colt's account as an advance by way of mortgage on property at Hollington; the other was for £48 18s. 7d., drawn by Sayer and Colt, local solicitors, for balance of purchase money due to him in respect to the sale of a house. Prisoner reserved his defence, and was committed to take his trial at the Quarter Sessions, bail being granted.

**A RECALCIBRANT BUILDER FURTHER FINED.**—Mr. George E. Baine, a builder, of 22, St. Dunstan's-road, Forest Gate, was summoned to Stratford police-court on Saturday by the East Ham Urban District Council for penalties in respect to non-compliance with an order made by the Court. In October the defendant was summoned and fined £5 for failing to remedy certain sanitary defects at 46, Rutland-road, East Ham, a house owned by him. An order was also made to do the work, with a continuing penalty of 10s. a day till it was done. But the defendant did not do the work, and the council thereupon stepped in and remedied the defects at a cost of £1 8s. 10d. The work was completed on January 14. Mr. W. B. Whittingham, the chairman, said it would be useless for the Bench to make orders of this sort unless they were enforced. The previous order of the Court would now be adhered to, and defendant would have to pay 10s. a day from the date of the order till the date of the completion of the work—viz., 67 days. Defendant must also pay £1 8s. 10d., the cost of the work done by the council, and 10s. 6d. Court costs, amounting in all to £35 9s. 4d.

**THE CENTRAL LONDON RAILWAY TUNNELS.**—At the Sheriff's Court, Red Lion-square, Holborn, on Wednesday, a case of importance to owners of property along the lines of the new electric railways was heard by Mr. Burchell and a special jury. It was a claim by the trustees of the late Frederick J. Blake against the Central London Railway Company for £539 for the purpose of repairing the residence No. 2, Marlborough-gate, Hyde Park, alleged to have suffered damage by subsidence due to the works of the railway company. It was alleged that the house in question had been structurally injured by the works of the company either primarily or by reason of the bursting of a water main owing to the tunnelling operations for the company's new line from the City to Shepherd's Bush. Amongst the experts called for the claimant were Mr. H. H. Collins, Mr. Arthur C. Pain, Mr. E. A. Gruning, and Mr. Henry Currey. On behalf of the railway company, Sir Douglas Fox, Mr. Cooper, Mr. George Weston, and others gave evidence, and it was contended that the system of tunnelling with the Greathead shield prevented any possibility of injury to adjacent buildings, and that the subsidence must have been caused by the bursting of the water-main owing to internal pressure. The jury returned a verdict for the railway company, on the ground that the damage was done by the bursting of the water-main, for which the railway company had not been shown to be in any way responsible. It was agreed that the claims pending in respect of adjoining houses should be governed, as regards the question of liability, by the finding of the jury in this case.

**HARROGATE WATERWORKS ARBITRATION.**—Mr. Shires Will, Q.C., made his award on Friday in connection with the Harrogate Corporation taking over the interests of the Harrogate Waterworks Company. The sum claimed by the company was £234,000, and the offer of the corporation before Parliament was £187,000. The umpire's award is £187,000. Under the conditions of the award, the unspent capital of the company, £2,363, and the reserve fund, £5,499, are to be set against the award.

The organ in Dagnall-street Baptist Chapel, St. Albans, was reopened last week after being enlarged by Messrs. Hill and Son, of London.

## Our Office Table.

SIR EDWARD J. POYNTER'S cartoon of St. David, which is an elaboration of the design prepared by that artist some years ago for a companion mosaic to the St. George, which fills the panel over the entrance to the Lords' corridor in the central hall at Westminster, is approaching completion; and Mr. Akers-Douglas hopes that before Parliament reassembles next year the work of reproducing it in detail in the panel over the entrance to the Commons' corridor will have been executed to the satisfaction of members interested. It may be remembered that last session a sum of £750 was voted in the Estimates towards the completion of the scheme of mosaic decoration in the central hall. A further cost of something like £200 is expected to be incurred during the forthcoming financial year.

MR. JOHN ALEXANDER BRODIE, M.Inst.C.E., of Cook-street, Liverpool, has been selected by the health committee of that city from 52 applicants, and will be recommended for appointment to the post of city engineer of Liverpool. Mr. Brodie, who is only 30 years of age, received his early training in the Coburg Dock of the Mersey Dock Board, next entering the Liverpool Corporation service, and afterwards practised as a civil engineer in Liverpool on his own account. He is Vice-President of the Liverpool Engineering Society, a Whitworth Scholar, and a member of the Institute of Civil Engineers. The commencing salary attached to the city engineership of Liverpool, which became vacant by the resignation of Mr. H. Percy Boulnois, since appointed an inspector under the Local Government Board, is £1,000. The other four selected candidates for the post were Mr. J. Patton Barber, M.Inst.C.E., surveyor to the vestry of St. Mary, Islington; Mr. E. J. Lovegrove, Assoc. M.Inst.C.E., engineer and surveyor to the Urban District Council, Hornsey; Mr. Philip H. Palmer, M.Inst.C.E., borough engineer and surveyor of Hastings; and Mr. A. E. White, M.Inst.C.E., city engineer of Hull.

IMPORTANT changes are, says the London correspondent of the *Manchester Guardian*, likely to take place before long in the surveying branch of the Department of Works and Public Buildings. Sir John Taylor, K.C.B., who has been chief surveyor for many years, contemplates retirement from his office in the course of the next few months, and it is expected that he will be succeeded by Mr. Henry Tanner, his chief assistant. But although Sir John Taylor gives up the onerous and responsible office in which he has long served the Crown, his services will not be completely lost to the department. It is understood that he will superintend the erection of the new War Office on what is known as the Carrington House site in Whitehall, as he has had much to do with the preparation of the plans for that building, and it would be manifestly convenient for him to see them carried out. As the houses now occupied by the Office of Works in Whitehall-place will be pulled down in connection with the War Office scheme, the First Commissioner and his staff will remove to Storey's Gate in the course of the ensuing summer.

At the meeting of the Plymouth Town Council on Tuesday, a recommendation by the borough surveyor and the special works committee of a new code of by-laws for regulating building operations in the borough was adopted. These proposals are of a very far-reaching character. Should they obtain the force of law, it will be no longer possible to lay out streets 24ft. in width, or to crowd houses on the land to the exclusion of proper means of approach. Greater regard will also have to be paid to the size of rooms, and to the manner of the erection of buildings, especially those designed for human occupation. Under the new regulations the width of streets is to be increased, there is to be no such thing as a "cul-de-sac," and there are to be back lanes. Under by-law 4, a street not more than 100 yards long is to be 36ft. wide, one of 200 yards 40ft. wide, and over 200 yards 45ft. wide.

The first of three lectures was delivered by Dr. Jean Paul Richter at the Royal Institute on Thursday in last week, the special topic being "Some Italian Pictures at the National Gallery," the paintings of the 14th century. The National Gallery had one peculiar feature in its favour in

that it possessed a not inconsiderable assemblage of the works of the Italian Trecento, the first brilliant period of the national art of the peninsula. But how far did these represent the great artists of that time? To Cimabue many works had been ascribed by Vasari, but these were so heterogeneous that it was impossible they should all be his. The Madonna of the Capella Rucellai in Florence must, on the grounds of style, be attributed by every unbiased critic to Duccio, not Cimabue, while the doubt was fully warranted that the altarpiece in the National Gallery ascribed to the latter master was not his at all, but could only be ranked as a schoolpiece of Duccio's. Of the school of Giotto there were many examples in the National Gallery, but not a single one of them could claim to come from the hands of the master himself. Only those who had seen his wall-paintings at Assisi, Padua, and Florence could appreciate the greatness of his art. The lecturer considered that little instruction was to be gained from the Florentine painters of the Trecento in the National Gallery, though in numbers they were more largely represented there than in any other public collection except at Florence. The one great Florentine painter of the Quattrocento who was most closely allied to the art of the Trecento was Fra Angelico, of whose work the National Gallery possessed one example of supreme merit in the "Resurrection of Christ." Dr. Richter concluded with a few words about the Trecento pictures of the Siennese school. Though Siena was only 30 miles from Florence, each city was an independent centre of art, and did not influence the other in the slightest degree. In the National Gallery there were four panel pictures by Duccio, who was the founder of the early school of Siena, the first place being taken by the triptych representing the Madonna with the saints Dominic and Catherine of Alexandria on either side. Of the other three the "Transfiguration" alone was in its original condition.

ON Saturday evening an art lecture was delivered in the Glasgow Corporation Art Galleries by Mr. T. L. Watson, F.R.I.B.A., his subject being Glasgow Cathedral. The chair was occupied by Councillor Dougan, M.D. The lecturer referred to the influence upon the development of Gothic architecture exercised by the numerous fires which occurred in the large churches of the 11th and 12th centuries. In order to make their religious buildings enduring as well as beautiful, the whole energy of the designers was directed to the problems of covering them with stone vaulting, and this resulted in the evolution not only of the arch rib vault, but of the pointed style of architecture. The earliest building of importance at Glasgow, the church erected by Achaius in the early years of the 12th century, was destroyed by fire in 1176, and a parallel to this was found in Canterbury, where the choir of the cathedral, erected at the same time as the church of Achaius, was burnt down in 1174. The rapidity with which the rebuilding of the choir at Canterbury had been carried out was contrasted with the prolonged operations under Bishops Jocelyn, Walter, and Bondington at Glasgow. The choir and lower church of Glasgow Cathedral were described in some detail and illustrated with a series of views. This part of the building was almost wholly of the 13th century, a period when there was no appreciable difference between the architecture of Scotland and that of England. We had thus the broad basis of English archæology to ground upon, and in contrast with other parts of the building and many other buildings in Scotland, its architecture was particularly clear. The architecture was of five distinct dates, each separated from the others by an interval sufficient to mark the development of the style. This development was indicated by a change of general design and by the introduction of a new type of moulding in the vaulting ribs in each section, which formed a regular sequence and illustrated the development of vaulting during the 13th century. The lecturer afterwards dealt in detail with the sequence and approximate dates of the various portions of the structure, and with the methods and machinery employed in erecting large buildings such as the cathedral in the 13th century.

The first examination by the Illinois State Board of Examiners of Architects was held on Jan. 15. Nineteen candidates for licenses to practise were examined, and eighteen were accepted. In addition to these eighteen, how-

ever, more than 600 architects already established have received licenses, under the provision of the law which entitles those who can satisfy the examiners that they were in actual practice in the State on the 1st of July, 1897, to a license without examination; and others, making application as practising architects, who have not yet received their papers, will undoubtedly obtain them. So far, 788 applications have been made. Several of these are from persons residing outside the State who desire permission to practise within its limits; indeed, architects in other States, who have clients in Illinois, cannot do work for them there without a local license.

A REPORT has been submitted to the Statute Labour Committee of Glasgow Corporation by Mr. John Lindsay, clerk of police, on the cost of taking over and maintaining the foot-pavements in the city. Excluding the footpaths of private streets, the extent of those of public streets is approximately 2,000,000 square yards, but including the footpaths of private streets, the above extent would be increased by one-fourth, giving a total extent of 2,500,000 square yards. Assuming that before the footpaths were taken over by the corporation they were put into a condition to the satisfaction of the master of works, the approximate annual cost of maintaining the same would, for public streets, be £8,500, and as regards private streets a further annual sum of £2,125. These sums are exclusive of the cost of subsequent renewal when completely worn out. This cost is, as regards public and private streets, estimated at £12,248 per annum, and in this sum no allowance is made for snowfalls. Mr. Lindsay explains that the foregoing figures are based on the assumption that the corporation possesses the power to take over all the footpaths in the city, but the corporation possesses no such legal power.

THE annual meeting of the Trustees of the Manchester Royal Infirmary was held on Friday. The report set forth the arrangements which have been made for the sale—if sanctioned by the corporation and the general body of trustees—of the land surrounding the infirmary. Three members of the medical staff opposed the proposal to retain the present infirmary and build a new one in some other place, holding that a fully equipped hospital might be built on the present site without encroaching on the open space. Eventually, on its being made clear that the adoption of the report in no way committed the trustees to the scheme approved by the joint committee, the report was approved, with the addition of a sentence declaring that the scheme, if accepted by the corporation, would be submitted to a special meeting of the trustees. It was urged by some of the trustees that it would be better to sell the whole of the present site and buildings and build a new hospital elsewhere, than be subject to the disadvantages of having two institutions.

We have received from Messrs. Sissons Bros. and Co., Ltd., of Hull, a sample of Hall's "Sanitary Washable Distemper," which is a new sanitary water-paint of great excellence. It is a strong disinfectant, and destroys all insects, vermin, as well as disease germs; yet it is free from caustic and alkali, and is non-poisonous. It is also perfectly washable three weeks after being applied. It may be put on a damp wall, and it stands better than oil-paint. Moreover, it will not scale off, and can be painted on or varnished without sizing. It is made in all colours, either rich, dark shades, or light tints, and as there is no lead in its composition it will not turn black, as many similar preparations do from the sulphurous gases in the atmosphere. Cracks and holes may be filled with the stiff material, which sets harder than plaster of Paris. It is readily applied, requiring no solution or liquid other than hot or cold water for mixing it ready for use, and it can be applied by inexperienced persons without difficulty. It is very economical in use—1lb. of water added to 4lb. of the distemper covers more than 25 square yards.

The parish church of All Saints', Leigh, Gloucestershire, which has been rebuilt from plans by Mr. C. E. Ponting, F.S.A., of Marlborough, was consecrated last week.

At a meeting of the Barnsley Town Council on Feb. 9, the plans of the proposed new opera-house to be erected in Eldon-street were approved and passed. The plans have been prepared by Mr. John P. Briggs, of 1, Arundel-street, Strand, London.

MEETINGS FOR THE ENSUING WEEK.

MONDAY.—Royal Institute of British Architects. "The Medieval Campanili of Rome," by J. Tavenor Perry. 8 p.m.  
Surveyors' Institution. "Legal Liability for Professional Opinion," by T. W. Wheeler, G.C., A.P.S.I.  
Carpenters' Hall Lectures. "Electric Motive Power," by Professor Silvanus P. Thompson, F.R.S. 8 p.m.  
Society of Arts. "The Principles of Design in Form," Cantor Lecture No. 2, by Hugh Stannus. 8 p.m.  
Liverpool Architectural Society. "Some Notes on St. George's Hall," by F. E. Pearce Edwards, A.R.I.B.A.

TUESDAY.—Institution of Civil Engineers. "Alternate-Current Motors," by Llewellyn B. Atkinson; and "Dublin Electric Tramway," by H. F. Parshall. 8 p.m.  
Society of Arts. "The Regalia of England," by Cyril Davenport. 8 p.m.  
Auctioneers' Institute. "Furniture: Past and Present," by W. Roland Peck, F.S.I., Vice-President. 8 p.m.  
Leeds and Yorkshire Architectural Society. Discussion Night.

WEDNESDAY.—Society of Arts. "Children's Sight," by R. Brudenell Carter, F.R.C.S. 8 p.m.

THURSDAY.—Society of Arts. "Egypt the Birthplace of Architecture," by G. A. T. Middleton, A.R.I.B.A. (illustrated by lantern views), St. James's Hall, Piccadilly, W. 8 p.m.  
Northern Architectural Association. Social Gathering of Sketching Club. Assembly Rooms, Barras Bridge, Newcastle-on-Tyne. 8 p.m.

FRIDAY.—Architectural Association. "Leadwork," by F. W. Troup, A.R.I.B.A. 7.30 p.m.

THE ARCHITECTURAL ASSOCIATION.  
FEBRUARY 25th, ORDINARY GENERAL MEETING, No. 9, Conduit-street, W., 7.30 p.m. Paper by Mr. F. W. TROUP, on "LEADWORK, PLAIN AND DECORATIVE" (with practical demonstrations).  
FEBRUARY 26th, SPRING VISIT to Claridge's Hotel, Brook-street, Grosvenor-square, W., by kind permission of the Architect, Mr. C. W. STEPHENS. Members to meet at the works at 2.30 p.m.  
E. HOWLEY SIM, Hon. Secs.  
G. B. CARVILLE, Hon. Secs.

The Society of Architects.

Founded 1884. Incorporated 1893.

THE FOURTH ORDINARY MEETING of the Society of Architects for the Session 1897-98 will be held at the Rooms of the Society, at St. James's Hall, Piccadilly, W., on THURSDAY, February 24th, 1898, at Eight o'clock p.m., when a Paper will be read by Mr. G. A. T. MIDDLETON, A.R.I.B.A. (Member), entitled "EGYPT, THE BIRTHPLACE OF ARCHITECTURE," illustrated by limelight views. Ladies' night.  
ELLIS MARSLAND, Hon. Sec.  
MONTAGU BALDWIN, M.A., Sec.

Trade News.

WAGES MOVEMENTS.

ASHFORD, KENT.—A settlement of the threatened dispute between employers and workmen in the building trade has been arrived at on the basis of a halfpenny per hour advance all round, and this to take effect from March 14. The employes reserve the right to raise the question of a further advance to skilled labour in 12 months' time if the state of the trade should warrant it.

CARDIFF.—Masters and men in the building trade of Cardiff met in conference on Wednesday night in last week, the former at the Royal Hotel, and the latter in the Gladstone Hall. Earlier in the day a joint conference was held between the representatives of both sides, lasting from 11 o'clock till 3.30, but no decision was arrived at. The representatives from both sides submitted the proposals to a general meeting in the evening, and the masters' association confirmed the proposals made by their representatives. The employers' meeting closed at 10 o'clock. The men's meeting was more protracted, and in the event was adjourned. The masters, therefore, await the result of the deferred meeting.

EDINBURGH MASONS AND EIGHT HOURS.—In accordance with the agreement come to between employers and men, the masons in Edinburgh and Leith commenced on Tuesday to work the eight hours' shift, the time-table ranging from seven a.m. to five p.m., with two hours off for meals. The arrangement has been generally observed.

PLYMOUTH.—In October last the Plymouth Journeymen Painters' Association gave their employes six months' notice of their intention to demand an increase of wages and a shorter number of working hours per week. Considerable negotiations have taken place on the matter, and terms have now been arranged which are said to be satisfactory to both parties.

The death is announced of Mr. Benjamin Suart, for many years managing director of Messrs. Maw and Co., Limited.

LATEST PRICES.

IRON, &c.		Per ton.	Per ton.
Rolled-Iron Joists, Belgian	.....	£6 0 0 to	£6 10 0
Rolled-Steel Joists, English	.....	6 10 0	7 10 0
Wrought-Iron Girder Plates	.....	5 15 0	6 10 0
Bar Iron, good Staffs	.....	7 0 0	8 0 0
Do., Lowmoor, Flat, Round, or Square	.....	17 0 0	17 0 0
Do., Welsh	.....	5 15 0	5 17 6
Boiler Plates, Iron—			
South Staffs	.....	7 17 6	8 5 0
Best Snedshill	.....	10 0 0	10 10 0
Angles 10s., Tees 20s. per ton extra.			
Builders' Hoop Iron, for bonding, &c.,	.....	£6 15s. 0d. per ton.	
Builders' Hoop Iron, galvanised,	.....	£5 10s. 0d. per ton.	
Galvanised Corrugated Sheet Iron—			
No. 18 to 20. No. 22 to 24.			
8ft. to 8ft. long, inclusive gauge	.....	£10 15 0	£11 0 0
Best ditto	.....	11 5 0	11 10 0
Cast-Iron Columns	.....	£6 0 0 to	£8 10 0
Cast-Iron Stanchions	.....	6 0 0	8 10 0
Cast-Iron Sash Weights	.....	—	4 2 6
Cast-Iron Socket Pipes—			
3in. diameter	.....	5 10 0	5 15 0
4in. to 6in.	.....	5 5 0	5 10 0
7in. to 24in. (all sizes)	.....	4 15 0	5 5 0
[Coated with composition, 2s. 6d. per ton extra; turned and bored joints, 5s. per ton extra.]			
Pig Iron—			
Cold Blast, Lilleshall	.....	105s. to	110s.
Hot Blast, ditto	.....	57s. 6d. to	62s. 6d.
Wrought-Iron Tubes—Discount off Standard Lists f.o.b.			
Gas-Tubes	.....	75p.c.	Fittings 77p.c.
Water-Tubes	.....	70	72½
Steam-Tubes	.....	62	65
Galvanised Gas-Tubes	.....	60	62½
Galvanised Water-Tubes	.....	55	57½
Galvanised Steam-Tubes	.....	45	47½
10cwt. casks. 5cwt. casks.			
Sheet Zinc, for roofing and working up	.....	£22 10 0 to	£23 10 0
Sheet Lead, 3lb. per sq. ft. super.	.....	14 7 6	15 7 6
Pig Lead, in lwt. pigs	.....	13 10 0	14 10 0
Lead Shot, in 28lb. bags	.....	17 10 0	18 10 0
Copper Sheets, sheathing and rods	.....	58 10 0	59 10 0
Copper, British Cake and Ingot	.....	51 10 0	52 10 6
Tin, Straits	.....	64 12 6	65 12 0
Do., English Ingots	.....	67 0 0	67 10 6
Spelter, Silesian	.....	17 7 6	18 7
Per ton.			
Cut Clasp Nails, 3in. to 6in.	.....	£8 15 0	£9 15 0
Cut Floor Brads	.....	8 10 0	9 10 0
Wire Nails (Points de Paris)—			
0 to 7	8 9 10 11 12 13 14 15	B.W.G.	
8/6 9/0 9/6 10/3 11/0 12/0 13/0 14/9 16/9		per cwt.	
TIMBER.			
Teak, Burmah	.....per load	£13 10 0 to	£15 10 0
" Bangkok	.....	10 10 0	15 0 0
Quebec pine, pitch	.....	—	6
" yellow	.....	2 2 6	4 2 0
" Oak	.....	3 15 0	5 0 0
" Birch	.....	3 15 0	5 0 0
" Elm	.....	3 15 0	5 0 0
" Ash	.....	3 0 0	4 10 0
Dantsic and Memel Oak	.....	2 10 0	3 5 0
Fir	.....	1 15 0	3 15 0
Wainscot, Riga p. log	.....	2 10 0	3 10 0
Lath, Dantsic, p.f.	.....	4 10 0	5 10 0
St. Petersburg	.....	5 0 0	6 10 0
Greenheart	.....	8 5 0	8 10 0
Box	.....	4 0 0	15 0 0
Sesuoia, U.S.A.	.....per cube foot	0 1 8	0 1 10
Mahogany, Cuba, per super foot			
lin. thick	.....	0 0 5	0 0 6
" Honduras	.....	0 0 4	0 0 6
" Mexican	.....	0 0 4	0 0 5
Cedar, Cuba	.....	0 0 4	0 0 4
" Honduras	.....	0 0 3	0 0 4
Satinwood	.....	0 0 6	0 1 2
Walnut, Italian	.....	0 0 3	0 0 7
Deals, per St. Petersburg Standard, 120—12ft. by 1½in. by 1½in.—			
Quebec, Pine, 1st	.....	£19 15 0 to	£25 15 0
" 2nd	.....	14 0 0	16 10 0
" 3rd	.....	6 10 0	11 0 0
Canada Spruce, 1st	.....	9 10 0	11 5 0
" 2nd and 3rd	.....	8 0 0	9 0 0
New Brunswick	.....	7 15 0	8 0 0
Riga	.....	6 15 0	7 15 0
St. Petersburg	.....	8 15 0	12 15 0
Swedish	.....	9 0 0	15 10 0
Finland	.....	7 10 0	8 0 0
White Sea	.....	9 0 0	16 0 0
Battens, all sorts	.....	5 0 0	20 0 0
Flooring Boards, per square of lin.—			
1st prepared	.....	£0 8 6	£0 15 6
2nd ditto	.....	0 7 0	0 12 0
Other qualities	.....	0 5 0	0 6 6
Staves, per standard M:—			
Quebec pipe	.....	—	—
U.S. ditto	.....	£35 0 0	£42 10 0
Memel, cr. pipe	.....	230 0 0	240 0 0
Memel, brack	.....	200 0 0	210 0 0
OILS.			
Linseed	.....per ton	£15 15 0 to	£16 0 0
Rapeseed, English pale	.....	24 5 0	24 10 0
Do., brown	.....	22 10 0	23 0 0
Cottonseed, refined	.....	13 15 0	14 5 0
Olive, Spanish	.....	31 0 0	33 0 0
Seal, pale	.....	23 10 0	24 0 0
Cocoon, Cochin	.....	28 0 0	28 10 0
Do., Ceylon	.....	22 0 0	22 10 0
Palm, Lagos	.....	23 0 0	23 10 0
Oleine	.....	18 15 0	19 15 0
Lubricating U.S.	.....per gal.	0 6 3	0 7 6
Petroleum, refined	.....	0 0 4	0 0 4
Tar, Stockholm	.....per barrel	1 0 0	1 5 0
Do., Archangel	.....	0 12 6	0 15 0
Turpentine, American	.....per ton	23 0 0	23 10 0

LIST OF COMPETITIONS OPEN.

New York—Sun Dial (Plaster Model)	500dol., 250dol.	Sac. National Sculpture Soc., 215, West 57th-street, New York	Feb. 28
Newcastle-on-Tyne—New Infirmary (Local Architects)	(No first) £150, £100, £50	Secretary Building Committee, Newcastle	Mar. 1
Carlisle—Silver Gilt Casket (to cost £63)		A. H. Collingwood, Town Clerk, 15, Fisher-street, Carlisle	" 12
Berwick-on-Tweed—Police-Station (£5,000 limit)	Commission of £50, £25	R. Weddell, Town Clerk, Berwick-on-Tweed	" 14
Llangathen—Stone Bridge, Dryslwyn Ford	£25, £15	Thomas Jones, Clerk, County Council Offices, Llandoverly	" 14
Winchester—Public Baths	50 Guineas, 25 Guineas	Walter Bailey, Town Clerk, Guildhall, Winchester	" 31
Belper—Sewage Disposal Schemes	£656, £438, £219	Joseph Pym, Clerk, Belper	May 1
Stockholm—City Railway Stations and Junctions		Consulate General, 27, Great Winchester-street, E.C.	Aug. 31
West Bangour, Linnithgowshire—Lunatic Asylum (limited to Scotch Architects)	£250, £200, £150, £100	A. Ferrier, Clerk, Parish Council Chambers, Castle-terr., Edinburgh	—
Southampton—Fireproof Flooring, Warming, &c., Municipal Lodging Houses		W. B. G. Bennett, Borough Surveyor, Southampton	—
Royal Aquarium—Design for Poster	10 Guineas	Edgar S. Shrubsole, Royal Aquarium, London	—
Lewisham—Clock Tower (£700 limit)		Sinkler and Oxenham, Hon. Secs., 55, Clarendon-road, Lewisham	—
Southwold—Pair of Villas, Church Green		E. W. Moore, High-street, Southwold	—

LIST OF TENDERS OPEN.

BUILDINGS.

Carleton—Nine Houses	Carleton Coal and Brick Co.	Greaves and Sidebottom, Architects, Ropergate Chmbrs, Pontefract	Feb. 19
Halifax—House, Rhodes-street	John Forsyth	F. L. Horsfall and Son, Architects, Lord-street, Halifax	" 19
Forres—House	Devon and Exeter Reformatory	Ross and Macbeth, Architects, Inverness	" 19
Gaerwen—Houses at Junction	Graham, Son, and Wilson	Arthur W. Jones, Plas Hen, Llandaniel	" 19
Whipton—Building	Northern Counties Club	E. H. Harbottle, County Chambers, Exeter	" 19
Woodbridge—Classroom at Grammar School	Duncan and Co.	F. J. A. Wood, Church-street, Woodbridge	" 19
Omagh—Business Premises, Market-street	Standing Joint Committee	Wm. Barker, Architect, Londonderry	" 19
Gostorth—Detached Residence	Wiley and Co., Engineers	Lister Newcombe, F.R.I.B.A., 89, Pilgrim-street, Newcastle-on-Tyne	" 19
Northampton—Additions to Infectious Hospital, Kingsthorpe	Midland Railway Co.	The Borough Engineer, Guildhall, Northampton	" 19
Morley—Eight Houses in East Park-street	Guardians of Mile End Old Town	G. A. Firth, Plumber, Morley	" 19
Londonderry—Alterations to Premises	Duncan Macgregor	W. E. Pinkerton, M.R.I.A., Architect, 8, Diamond, Derry	" 19
Seascale—Dwelling House	Managers	W. E. Pinkerton, M.R.I.A., Architect, 8, Diamond, Derry	" 19
Wallsend—Rebuilding the Black Bull Inn	George Glennie	S. Railway-terrace, Seascale	" 19
Torphins—Additions to Learney Arms Hotel	Co-operative Society	Hope and Maxwell, Architects, 40, Westgate-rd., Newcastle-on-Tyne	" 19
Ashington—Tower and Vestries for Church	Industrial Society	Jenkins and Marr, Architects, 16, Bridge-street, Aberdeen	" 19
Camborne—Two Houses	School Board	Hicks & Charlewood, Architects, 42, Grainger-st., Newcastle-on-T.	" 19
Halifax—House in Rhodes-street	Corporation	J. Bennetts, Vellyn Saundry, Camborne	" 19
Wortley, Leeds—Wesleyan Sunday School	Mile-End Guardians	Chas. F. L. Horsfall and Son, Lord-street Chambers, Halifax	" 19
Hereford—Repairs to Front of Shire Hall	Urban District Council	G. F. Wilkinson, Architect, 35, Park-street, Leeds	" 19
Hensingham—House, 6, Marina-terrace	Dix and Co.	J. F. Symonds, Clerk of the Peace, Shire Hall, Hereford	" 19
Findhorn—Villa	Trustees, Prim. Meth. Chapel	Geo. Boyd, 33, Queen-street, Whitehaven	" 19
Exeter—Offices in St. Thomas	Corporation	John Forrest, Architect, 129, High-street, Forres	" 19
Hull—Restoration of Exterior St. Paul's Church	Managers	Charles E. Ware, Architect, Gandy-street, Exeter	" 19
Barry Dock—Additions to Culley's Hotel	George Glennie	Smith, Brodrick, & Lowther, Architects, York Chmbrs, 77, Lowzate	" 19
Cork—Seven Houses, Gaggin's-lane	Co-operative Society	Gethin, Wallis, and Robertson, Architects, Westgate-st., Cardiff	" 19
Burstock—Primitive Methodist Chapel and School	Industrial Society	M. J. M'Mullen, B.E., South Mall, Cork	" 19
Morecambe—Office	School Board	Brownlow Thompson, Architect, 15, Parliament-street, Hull	" 19
Bradford—Four Houses, Ounsforth-street	Corporation	The Secretary, Works Committee, Midland Railway, Derby	" 19
London, E.—Repairs at Infirmary, and Smiths' Work at Workhouse, Bancroft-road	Mile-End Guardians	Abm. Sharp, Architect, Albany Buildings, Market-street, Bradford	" 19
Leeds—Four Shops, Central-road	Urban District Council	W. Thacker, Clerk, Guardians' Offices, Bancroft-road, London, E.	" 21
Connel Ferry—Villa	Dix and Co.	The Town Clerk, Town Hall, Leeds	" 21
Elgin—Villa	Trustees, Prim. Meth. Chapel	Wm. MacKenzie, Architect, 42, Stevenson-street, Oban	" 21
Tredegar—County School	Corporation	Robt. B. Pratt, A.R.I.B.A., County Bank House, Elgin	" 21
Knockaney—Repairs to R.C. Church	Managers	C. Dauncey, Solicitor, Tredegar	" 21
Insch—House, Little Mains	George Glennie	Rev. J. M. Bourke, P.P., Knockaney	" 21
Great Yarmouth—Additions, Mineral Water Mnfy., Howard-st.	Co-operative Society	John Craigen, Solicitor, 193, Union-street, Aberdeen	" 21
Amble—Bakery	Industrial Society	Chas. G. Baker, Architect, Yarmouth	" 21
Bradford Moor—Stables and Cart Sheds	School Board	W. B. Hindmarsh, Architect, Alnwick	" 21
Birkenshaw—Eight Through Houses, Shirley-road	Corporation	Abm. Sharp, Architect, Albany Buildings, Market-street, Bradford	" 21
Carlisle—Six Houses and Shop, Greystone-road and Tullie-street	Mile-End Guardians	W. Outhwaite, Secretary, Bradford-road, Birkenshaw	" 21
Bath—Enlargement of Oak Street Schools	Urban District Council	A. W. Johnston, Architect, 81, Castle-street, Carlisle	" 21
Armagh—Mall School Reconstruction	Dix and Co.	William J. Wilcox, Architect, 1, Belmont, Bath	" 21
Plymouth—Refuse Destructor	Trustees, Prim. Meth. Chapel	J. J. Phillips and Sons, Architects, 61, Royal-avenue, Belfast	" 21
Pontefract—Additions to King's School	Corporation	Jas. Paton, Borough Surveyor, Plymouth	" 21
Neath—Schools, Gnoil Park-road (for 950 children)	Managers	Tennant and Bagley, Architects, Pontefract	" 21
Leeds—Four Shops, Central-road	George Glennie	J. Cook Rees, St. Thomas's Chambers, Neath	" 21
London, E.—Building Repairs at Infirmary, Smith's Work at Workhouse, Bancroft-road	Co-operative Society	The Town Clerk, Town Hall, Leeds	" 21
Keighley—Works, Premises, North-street and High-street	Industrial Society	William Thacker, Clerk to Guardians, Bancroft-road, London, E.	" 21
Portishead—Mortuary at Burial Ground	School Board	John Judson and Moore, Architects, York Chambers, Keighley	" 21
Beoston—Sunday School & Enlargement of Prim. Meth. Chapel	Corporation	T. J. Moss Flower, A.M.I.C.E., Carlton Chambers, Bristol	" 21
Menston—Eleven Terrace Houses	Managers	Howdill and Howdill, Architects, 24, Albion-street, Leeds	" 21
Lurgan—Waiting-Rooms at Station	George Glennie	Harold Chippindale, Architect, Springfield, Guseley	" 21
St. Ives—Chapel and Schoolroom	Co-operative Society	T. Morrison, Secretary, Amiens-street Terminus, Dublin	" 22
Belfast—Pump-House at Workhouse	Industrial Society	Rev. S. Wright, St. Ives, Cornwall	" 22
Huddersfield—Warehouse and Offices, Cloagh House Mills	School Board	Young and Mackenzie, Architects, 7, Donegal-square East, Belfast	" 22
Runham—Additions to Board School	Corporation	John Kirk and Sons, Architects, Huddersfield	" 23
Kendal—Three Shops and Houses	Managers	H. Chamberlin, Clerk, 14, Queen-street, Great Yarmouth	" 23
Eskmeals—House at Proof Range	George Glennie	John Stalker, M.S.A., Architect, Kendal	" 23
Kendal—Enlarging No. 20, Greenside	Co-operative Society	Austin and Paley, Architects, Lancaster	" 23
Preston—Royal Cross School for Deaf	Industrial Society	Stephen Shaw, F.R.I.B.A., Architect, Kendal	" 23
Budleigh Salterton—Police Cells	School Board	Sames and Green, 65, Northgate, Blackburn	" 23
Middlesbrough—Additions to Grange-road School	Corporation	E. H. Harbottle, County Surveyor, Queen-street, Exeter	" 23
Marsden—Chancel and Morning Chapel, Marsden Church	Managers	J. Mitchell Bottomley, 23, Albert-road, Middlesbrough	" 23
Batley—Alterations to Board Schools at Purley	George Glennie	John Kirk and Sons, Huddersfield	" 24
Dartford—Improving Steps, Mount Pleasant-road	Co-operative Society	Walter Hanstock, Architect, Branch-road, Batley	" 24
Oakworth—Mill Shed	Industrial Society	J. C. Hayward, Clerk, Sessions House, Dartford	" 24
Hanley—Brewery, Victoria Square	School Board	John Judson and Moore, Architects, Oakworth, near Keighley	" 24
Paulton—Wesleyan Day School	Corporation	R. Scrivener and Sons, Architects, Howard Place, Hanley	" 24
Wilton—Sunday School	Managers	W. F. Bird, Architect, Midson, Norton	" 24
Balife—Four-story Warehouse, Clifton Mills	George Glennie	J. Davison, 32, New-street, Wigton	" 24
Carlisle—Electric-Lighting Station	Co-operative Society	Joseph F. Walsh, Architect, Lanc. & York Bank Chambers, Halifax	" 24
Elgin—Pluscarden Memorial Church	Industrial Society	Henry C. Marks, City Engineer, 33, Fisher-street, Carlisle	" 25
Queensbury—Wesleyan Sunday School	School Board	A. and W. Reid and Wittet, Architects, Elgin	" 25
Thorne—House	Corporation	Sidney Mann, Secretary, Mountain, Queensbury	" 25
Canterbury—Station for Electricity & Refuse-Destructor Works	Managers	H. B. Thorp, Architect, Goolse	" 25
Kendal—Shop and House	George Glennie	Henry Fielding, Town Clerk, Canterbury	" 26
Cupar—Six Attendant's Cottages at Asylum	Co-operative Society	John Stalker, M.S.A., Architect, Kendal	" 26
Wolverhampton—Swimming Bath and Assembly Hall	Industrial Society	J. Osborne, Clerk to the Board, Cupar	" 26
Nevin—New Church	School Board	P. W. Bradley, Borough Surveyor, Wolverhampton	" 27
Workington—House, Belle Isle-street	Corporation	P. Shearson Gregory, Architect, High-street, Bangor	" 27
Keighley—Two Shops and Dwelling Houses, Henry-street	Managers	W. G. Scott, Architect, Victoria Buildings, Workington	" 28
Kirkpatrick-Fleming—Public Hall	George Glennie	W. H. and A. Sugden, Architects, Cuvendish-street, Keighley	" 28
Lyme Regis—Five Almshouses	Co-operative Society	C. F. Brown, Secy., School House, Kirkpatrick-Fleming, Ecclefechan	" 28
Cymmer—Alterations to Pishag Baptist Chapel	Industrial Society	M. C. Preston, Town Clerk, Lyme Regis	" 28
Troedrihwfuch—Thirty-one Houses; a Road 320ft. long	School Board	D. Jones, Secretary, 146, High-street, Cymmer, Porth	" 28
Malvern—Sanatorium	Managers	Sydney J. Phillips, Secretary, Troedrihwfuch Inn	" 28
Clwybont—Alterations to Schools	George Glennie	Jenkin Davies, London House, Penygroes, Llandeblie	" 28
Moretonhamstead—Enlarging Convalescent Home	Co-operative Society	William Lambert, Clerk to Committee, Malvern	Mar. 1
Bromley, E.—Alterations and Additions at Asylum, Devons-rd.	Industrial Society	W. D. Pritchard, Clerk, Clwybont	" 1
Moulton—Alterations to School	School Board	Edward Richards, Architect, Manor Office, 3, Park-crescent, Torquay	" 1
Bangor—Friars School	Managers	Robt. Foskett, Clerk to Managers, Asylum, Bromley, Middlesex, E.	" 1
		C. Dorman, Architect, Northampton	" 1
		R. Hughes Pritchard, Clerk to the Governors, Bangor	" 1

BUILDINGS—continued.

Douglas, Isle of Man—Enlargement of Post Office	H.M. Commissioners of Works	Hon. Reginald B. Brett, Sec. H.M. Office of Works, Whitehall-pl. S.W. Mar.	1
Llanrwst—Alterations to Court House	Denbighshire County Council	Ll. Adams, Clerk of Peace, 5, Castle-street, Ruthen	1
Sunderland—Bridge, Station Buildings, and Approaches at Pallion Station	North-Eastern Railway	C. N. Wilkinson, Secretary, York	2
Cardiff—School, Marlborough-road	School Board	J. J. Jackson, Clerk, School Board Offices, Howard-gardens, Cardiff	2
Blaydon-on-Tyne—Engine Shed, Offices, &c.	North-Eastern Railway	C. N. Wilkinson, Secretary, York	2
Thorbury—Infant School	School Board	Samuel Fudge, Architect, Thornbury	3
Mitchelstown—Medical Officers' Residence	Guardians	Richard Fitzgibbon, Clerk, Mitchelstown	3
Pendarron—Twenty Dwelling Houses	Awelrlyn Building Club	J. R. Davies, 22, Glebeland-street, Merthyr Tydfil	3
Llanely—Three Schools	School Board	J. B. Morgan, Architect, New-road, Llanely	3
Halifax—Villa, Greenroyd Estate	Industrial Co-operative Society	Geo. Buckley and Son, Architects, Tower Chambers, Halifax	4
Stalybridge—Fifteen Houses	H.M. Commissioners of Works	Secretary, Grosvenor-street, Stalybridge	4
Birmingham—Building in Yard of Head Post Office	Rev. Francis Healy, P.P.	Hon. Reginald B. Brett, Sec. H.M. Office of Works, Whitehall-pl. S.W.	4
Gortin—Church	London County Council	Edward J. Toye, Architect, Strand, Derry	4
Lewisham—Fire-Engine Station, High-street	Corporation	C. J. Stewart, Clerk, Spring-gardens, S.W.	8
Norwich—Erection and Maintenance of Technical Institute (for Six Months)	Geo. B. Kennett, Town Clerk, Guildhall, Norwich		12
Halifax—Villa, Shircot Green-road	Geo. Buckley and Son, Architects, Tower Chambers, Halifax		12
Chadwell Heath—Superstructure of Asylum (800 patients), &c.	Council	Fred. E. Hilleary, Town Clerk, Town Hall, West Ham, E.	14
Dartford—Additional Buildings, West Hill	Guardians of Dartford Union	J. C. Hayward, Clerk, Sessions House, Dartford	14
Sheffield—Male Infirmary Ward at Workhouse	Guardians, Ecclesall Bierlow Union	Thomas W. Smith, Clerk, Union Offices, The Edge, Sheffield	21
Rugby—Additions to Graziers' Arms Inn	Northampton Brewery Company	T. W. Willard, Architect, Rugby	
Ramsgate—Altering No. 34, Westcliffe	Reginald Pope, Architect, Folkestone		
Folkestone—Factory Chimney (150ft. high), Electricity Supply Works	Pier Company	Price and Wooler, Architects, Waterloo-st., Weston-super-Mare	
Weston-super-Mare—Rebuilding Pavilion	Mrs. Griffiths	W. W. Robinson, Architect, 10, King-street, Hereford	
Hereford—Three Villas, White Cross-road	Charles Lilley	H. E. and A. Bown, Architects, Harrogate	
Harrogate—Additions to Harlow Inn, Harrogate	F. W. Dawson	W. Griffiths, Architect, Falcon Chambers, Llanely	
Llanely—Stables and Out-Buildings, Maesarddafen	A. Bell	J. C. Martin, Luzon, Brixham, Devon	
Brixham—New Roof, St. Mary's Church	Hyde's Brewery Co., Rusholme	F. J. C. Carruthers, Architect, 25, Buccleugh-street, Dumfries	
Annam—Station Hotel	Sanitary Steam Laundry Co.	Mosley & Anderson, Architects, Goodyear Chambers, Northampton	
Finedon—Six Houses, Banks-road	William Braithwaite	Frank Bindloss, Architect, 4, Chapel-walks, Manchester	
Cheadle Hulme—Additions to All Saints' Church	J. Wolfe	Kay-Shuttleworth Estate Office, Gawthorpe Hall, Burnley	
Ightenhill—Farmhouse and Homestead, Hill Farm	Wm. Dixon	Ambler and Bownman, Architects, 9, Park-place, Leeds	
Leeds—Victoria Arcade, Lands-lane and Upperhead-row	Trustees	William Squires, Architect, Royal Exchange Chambers, Leeds	
Harrogate—House	Miss Stevens	P. P. Metge, C.E., 9, Hartcourt-terrace, Dublin	
Killinure—Rebuilding Mansion and Building Farm Offices	Major C. J. Russel, Malton	Percy Robinson, Architect, 340, Burley-hill, Leeds	
Kirkstall—Sixteen Houses	Owners of Garforth Colliery	W. F. Braithwaite, Architect, 6, South-parade, Leeds	
Leeds—Sunday School, Ventnor-street	Headmaster	Tom Cook, M.S.A., Architect, 39, Victoria Buildings, Manchester	
Manchester—Two Shops and House at Fairfield	W. Postlethwaite	Wm. Bennett, Superintendent, Royal Baths, Harrogate	
Halifax—Converting Two Shops into Bathrooms	Co-operative Creamery	Baxendall and Critchley, Architects, The Grove, Ilkley	
Ilkley—Steam Laundry, Cottages, and Stables	J. Gordon Black, Harrogate	The Secretary, Borstal Manor Cement Co., Borstal	
Borstal, Kent—Four Cement Kilns and Chimney	Provident Co-operative Society	J. Peakman, Architect, Hopwood Bank, Horsforth	
Newlay—Additions to House	George A. Hammond, Architect, &c., Rochdale and Heywood	E. Whitlock, Architect, 26, Scale-road, Hull	
Hull—Additions to Shop, Hessel-road	Frank Trythall, 11, Trevenon-terrace, Camborne	Arthur Hill, B.E., M.R.I.A., 22, George's-street, Cork	
Cork—House, Douglas-road	Guardians of Rochdale Union	Louis F. Eagleton, Architect, Bank Chambers, King's Lynn	
Dersingham—Additions to Public-House	John Smetham	W. Rounthwaite, A.R.I.B.A., Archt., Mosley-st., Newtle-on-Tyne	
Newcastle-on-Tyne—Villa, Rowland's Gill	Provent Co-operative Society	W. Griffiths, Architect, Falcon Chambers, Llanely	
Llanely—Three Villas and Residences, New-road	John Smetham	A. R. F. Trew, M.S.A., 22, Broad-street, Bristol	
Clifton—Free Methodist Chapel, Jacob's Well	Provent Co-operative Society	William Squires, Royal Exchange Chambers, Leeds	
Harrogate—House	John Smetham	Abraham Friend, Architect, 50, Bowbridge-road, Newark	
Newark—Six Residences, Spital Estate	Provent Co-operative Society	Jolly and Buckley, Architects, High-street, Chorley, Lancs.	
Euxton—Farm Buildings at Runshaw Moor	Provent Co-operative Society	C. H. Channon, Architect, Malton	
Filey—Pair of Villas	Provent Co-operative Society	The Secretary, Station-road, Haslingden	
Haslingden—Workmen's Club	Provent Co-operative Society	R. Routledge, Manager, Garforth Colliery	
Garforth Colliery—Eight Cottages	Provent Co-operative Society	Wm. J. W. Roome, M.S.A., Whitehall Buildings, Ann-st., Belfast	
Bangor, Co. Down—Presbyterian Church	Provent Co-operative Society	Jas. Emes, Architect, 151, Ebury-street, S.W.	
Ramsgate—Wing to Grammar School	Provent Co-operative Society	B. Priestley Shires, Architect, Central Exchange, Plymouth	
Devonport—Rebuilding the Shades Inn	Provent Co-operative Society	A. E. Dixon, A.R.I.B.A., Architect, 5, Park-lane, Leeds	
Bramley—Two Terrace Houses, Victoria Park Estate	Provent Co-operative Society	E. M. Young, Architect, 90, Duke-street, Barrow	
Barrow-in-Furness—Alterations to House	Provent Co-operative Society	C. Telford Evans, Architect, 8, Queen-street, Cardiff	
Abertillery—134 Colliery Houses at Six Bells	Provent Co-operative Society	J. Edward Still, Architect, 82, Queen-street, Cheapside, E.C.	
Chingford—Block of Shops	Provent Co-operative Society	Geo. F. Graham, President, Clones	
Clones—Creamery	Provent Co-operative Society	The Buxton Lime Firms Company, Limited, 8, Quadrant, Buxton	
Buxton—Twelve Cottages, Harpur Hill	Provent Co-operative Society	D. Donaldson and S. G. Linton, Hon. Secretaries, Derrygonnelly	
Derrygonnelly—Creamery	Provent Co-operative Society	Whitehead and Smetham, Architects, Albert Chambers, Harrogate	
Burley-in-Wharfedale—Ten Workmen's Houses	Provent Co-operative Society	W. H. Raffles, Architect, 9, Argyle-street, Regent-street, W.	
Eastbourne—House and Shop	Provent Co-operative Society	Russell and Lockwood, Architects, 16, Waring-street, Belfast	
Belfast—Semi-Detached Villas, Whitehead	Provent Co-operative Society	Fairbank and Wall, Architects, Craven Bank Chambers, Bradford	
Farsley—Semi-Detached Villas, New-street	Provent Co-operative Society	R. N. Somerville, County Surveyor, Cavay	
Bal inagh—Constabulary Barracks	Provent Co-operative Society	W. and D. Thornton, Architects, 21, King-street, Wakefield	
Wakefield—House, Oxford-road	Provent Co-operative Society	Forman & Aston, Architects, Queen's Bldgs, Royal Avenue, Belfast	
Ballynafeigh—Methodist Church	Provent Co-operative Society	The Secretary, Ashington Coal Co., Ashington	
Ashington—Infant Schools	Provent Co-operative Society	Fredk. W. Dixon, Architect, Trevelyan Buildings, Manchester	
Middleton—Store and Three Houses, Mills Hill	Provent Co-operative Society	Fenton Geo. Harris, Clerk, Estate Offices, Usk, Mon.	
Usk—Repairs and Additions to Buildings, Higher Grade School	Provent Co-operative Society	C. Bailey, Architect, Quaker's Yard, Cardiff	
Aberfan—Four Cottages	Provent Co-operative Society	W. Borough Hill, Architect, Southampton	
Winchester—Cottages, Barton Close	Provent Co-operative Society	J. Platts, Architect, Old Bank Buildings, Rotherham	
Rawmarsh—Twelve Cottages, Goosebuti-street	Provent Co-operative Society	Wm. Dent, Architect and Engineer, Railway-street, Nelson	
Nelson—Eight Houses, Victoria-terrace	Provent Co-operative Society	Fredk. W. Dixon, Architect, Trevelyan Buildings, Manchester	
Manchester—Mission Hall and Two Shops, Oldham-road	Provent Co-operative Society	Whitehead and Smetham, Architects, Albert Chambers, Harrogate	
Harrogate—Offices, Albert Chambers	Provent Co-operative Society	W. Squires, Architect, Royal Exchange Chambers, Leeds	
Leeds—Five Houses, Brudenell-road	Provent Co-operative Society	John Judson and Moore, Architects, York Chambers, Keighley	
Keighley—Bonding Warehouse, Cooke-street	Provent Co-operative Society	J. F. Royce, 9, Station-square, Harrogate	
Harrogate—Pair of Houses in Park Drive	Provent Co-operative Society	W. Borough Hill, Architect, Southampton	
Winchester—Cottages, Queensland Estate	Provent Co-operative Society	Colin C. MacGill, Estate Office, Dalmainy	
Dalmainy—Cottage	Provent Co-operative Society	George A. Hammond, Architect, &c., Rochdale and Heywood	
Wardleworth—Branch Shop	Provent Co-operative Society	Frank Trythall, 11, Trevenon-terrace, Camborne	
Camborne—Rebuilding of 10, Trevenon-terrace	Provent Co-operative Society	The Architect, 101, Burley Lodge-road, Leeds	
Bramley—Two Houses, Victoria Park Estate	Provent Co-operative Society	E. H. Bruton, F.R.I.B.A., Architect, 15, Queen-street, Cardiff	
Gwynfi—New Parish Church	Provent Co-operative Society	Butterworth and Duncan, 4, South-parade, Rochdale	
Middlewood—Cottage Homes	Provent Co-operative Society	James Rickard, Doris-street, Kennington Cross, S.E.	
Honor Oak, S.E.—House	Provent Co-operative Society	Harry W. Taylor, Architect, St. Nicholas Chambers, Newcastle-on-T.	
West Kenton—House, Westerhope	Provent Co-operative Society	C. S. Nelson and R. N. Savage, Architects, 15, Park-row, Leeds	
West Ardsley—Alterations and Additions to Boyle Hall	Provent Co-operative Society	John Hutton, M.S.I., Architect, &c., Kendal	
Kendal—Alterations to Shop Premises	Provent Co-operative Society		

ENGINEERING.

Uppermill—Rebuilding Bridge	West Riding County Council	J. Vickers Edwards, County Surveyor, Wakefield	Feb. 19
Torres—Harbour Defence Works (estimated cost, 754,430fr.)	District Committee	Department of Public Works, Prefect of Sassari, France	19
Aberdeen—Extension of Water Main	Urban District Council	A. Clark, District Clerk, Bridge-street, Aberdeen	19
Gudhjem—Harbour Works	Urban District Council	Tilbud paa Havnebygning i Gudhjem, Denmark	19
Portland—Waterworks	Urban District Council	Ernest J. Elford, C.E., Engineer, Council Offices, New-rd, Portland	19
Bridgnorth—Provision and Laying of a 7in. Main (1,800 yards in length)	Corporation	J. Taylor, Sons, & Santo Crimp, C.E., 27, Gt. George-st., Westminster	21
Chathill—Raising Water Tank	North Sunderland Waterworks Co.	J. Ewing, Secretary, Sea House, Chathill	21
Plymouth—Refuse Destructor	Urban District Council	James Paton, Borough Engineer, Plymouth	21
Stevenage—Horizontal Engine, Cornish Boiler, and Pumps.	Urban District Council	John Gillespie, Engineer, Stevenage	21
Construction of Boiler-House, and Sinking Well	Great Western Railway Company	G. K. Mills, Secretary, Paddington Station, London	22
Plymouth—Dock Entrance	Vestry of St. Pancras	C. H. F. Barrett, Vestry Clerk, Vestry Hall, Pancras-road, N.W.	22
London, N.W.—Marine Boilers	Corporation	Alexander Hellard, Town Clerk, Town Hall, Portsmouth	22
Portsmouth—Lancashire Boilers and Pumps	Corporation	W. Verral, Town Clerk, Worthing	22
Worthing—Covering Reservoir	Urban District Council	E. J. Elford, C.E., Engineer, Council Offices, New-road, Portland	22
Portland—Waterworks	Corporation	William Gregson, Town Clerk, Southend-on-Sea	23
Southend-on-Sea—Widening Pier and Contracting Tramway	Water Commissioners	L. L. Macassey, C.E., Waterworks Office, Belfast	23
Passing Place	Rural District Council	A. W. Knott, Clerk, 14, Foregate-street, Worcester	23
Belfast—Pumping Engines, Old Park	Town Council	Henry Fielding, Town Clerk, Lanterbury	24
Martley—Water Supply Works	Bengal-Nagpur Railway Company	The Company's Offices, 132, Gresham-House, Old Broad-st., E.C.	24
Canterbury—Electric Wiring, &c., Beane Institute	Corporation	G. Wilkinson, Electrical Engineer, Harrogate	24
London—Engines with Tenders	Corporation	The Town Clerk, Guildhall, Shrewsbury	24
Harrogate—Sewage Pumping Plant	Highway Committee	E. Geo. Mawbey, C.E., Borough Surveyor, Town Hall, Leicester	25
Shrewsbury—Sludge-Pressing Machinery	Corporation	Thos. Hewson, Waterworks Engineer, Municipal Buildings, Leeds	25
Leicester—Bridges over the Willow Brook at St. Barnabas-road, Bridge-street, and Stonebridge-street			
Leeds—Water Main between Harehills Reservoir & Hunslet-rd.			

ENGINEERING—continued.

Mallow—Waterworks Alterations	Guardians	Maurice Regan, Clerk, Poor Law Office, Mallow	Feb. 25
Huy—Improvement Works, River Meuse (est. cost, 99,136 70fr.)	Forfar District Committee	M. Fendius, Ingenieur, &c., Liege	25
Clova—Stone Bridge over South Esk		John P. Anderson, District Clerk, Municipal Buildings, Forfar	26
Denbigh—Cooking Apparatus at North Wales Lunatic Asylum		Wm. Barker, Clerk to the Visitors, Denbigh	26
Guipuzcoa, Bilbao—Electric Tramway (30 miles) from Zumarrago to Zumaya		Commercial Department of Foreign Office, Whitehall, S.W.	28
Reife—Harbour Improvements and Docks, &c.	Water Company	Department of Public Works, Reife, Brazil	28
Dorking—Engine and Pumps	Government	T. A. Sommers Scott, Secretary, Dorking	28
Pernambuco—Port Works	Corporation	Brazilian Ministry of Public Works, Rio de Janeiro	28
Southwold—New Bridge over the Buss Creek	North-Eastern Railway	E. R. Cooper, Town Clerk, Southwold	Mar. 1
Middlesbrough—Extension of Dock		C. N. Wilkinson, Secretary, York	2
Wimble Hill, Hants—Water Tower, Pumps, Engine, Fire Hydrant, &c., at School and Infirmary	Managers Farnham School District Harbour Trustees	Edgar Kempson, Clerk to Managers, West-street, Farnham	2
Scrabster—Extension of Harbour		James Brims, Clerk to the Trustees, Thurso	3
Salford—Extending and Widening Regent Road Bridge	Weaver Navigation Trustees	Borough Engineer's Office, Town Hall, Salford	4
Northwich—Electric Plant	Northallerton Rural District Council	The Clerk, Weaver Navigation Offices, Northwich	5
Appleton Wake—Stone Bridge over Wiske	County Council	W. Fowler, Clerk, Northallerton	9
Dorstone—Carriage Bridge across the Dore	Wallasey Urban District Council	J. F. Symonds, Clerk, Shire Hall, Dorstone	12
Egremont—Engine and Boilers		H. W. Cook, Clerk, Church-street, Egremont, Cheshire	17
Sophia—Electric Lighting of Town		The Mayor, Sophia, Bulgaria	17
Madras—Utilisation of Water of Periyar Lake		Chief Engineer for Irrigation, Madras	July 1
Leeds—Settling Tank, Meanwood Tannery	Harold Nickolls	Thomas Winn, Architect, 90, Albion-street, Leeds	—
Northampton—Water Main, &c. (two miles)	Rural District Council	Wm. Hull, Architect, 12, St. Giles's-street, Northampton	—
Brindisi—Works to Harbour	Italian Government	Commercial Department, Foreign Office, Whitehall, S.W.	—
Rosecommon—Drying Apparatus in Workhouse		Ty. O'Keefe, Clerk, Union Office, Rosecommon	—
Lungro—Water-Supply Works (estimated cost, £1,756)		Municipal Authorities, Lungro (Province of Cosenza)	—
Bradford—Boiler House and Seating		F. Holland, Engineer, 11, Parkinson's Chmbs, Hustlergate, Bradford	—
Bramshall—Water-Supply Boring	Uttoxeter Rural District Council	F. S. Hawthorn, Clerk, Uttoxeter	—

FENCING AND WALLS.

Ogwell—Walling at Canada Barn, Ogwell	D. R. Scrutton	Rendell and Symons, F.S.I., Surveyors, Newton Abbot and Totnes	Feb. 19
Denholme—Dry Fence Wall on site of Sewage Farm, Doe Park	Urban District Council	W. B. Woodhead and Son, Civil Engineers, 18, Exchange, Bradford	21
Blackburn—W.I. Fencing (1,800 yards run)	Rural District Council	E. E. Radcliffe, Clerk, Union Offices, Blackburn	25

FURNITURE AND FITTINGS.

Fermoy—Iron Bedsteads	Guardians	Peter O'Neill, Clerk, Workhouse, Fermoy	Feb. 19
Wellingborough—Infirmary Chairs and Tables	Guardians	William Jackson, Clerk, West End House, Wellingborough	22
Belfast—100 Chairs	Guardians	James C. Neeson, Clerk, Belfast	22

PAINTING.

Swansea—Council Chamber and Courts in Guildhall	Town Council	Jno. Thomas, Town Clerk, Guildhall, Swansea	Feb. 19
Morley—Electric-Lighting Station, Corporation-street	Urban District Council	E. B. Borough Hopkins, Town Clerk, Town Hall, Morley	23
Hornsey—Isolation Hospital, Muswell Hill	Urban District Council	E. J. Lovegrove, C.E., Engineer, Southwood-lane, Highgate, N.	28
Waterloo—Painting and Decorating Town Hall	Urban District Council	F. Spencer Yates, A.M.I.C.E., Surveyor, Town Hall, Waterloo	28
Hornsey—Painting Lamp Columns and Street Name Plates	Urban District Council	E. J. Lovegrove, C.E., Engineer, Southwood-lane, Highgate, N.	28
London—Externally to Rental Property (No. 1)	Midland Railway Co.	James Williams, Secretary, Derby	Mar. 4
London—Externally to Rental Property (No. 2)	Midland Railway Co.	James Williams, Secretary, Derby	4
London—Goods Depot at Whitecross-street	Midland Railway Co.	James Williams, Secretary, Derby	4
Burton—Passenger Station	Midland Railway Co.	James Williams, Secretary, Derby	4
Walsall and Wolverhampton—Goods Depots	Midland Railway Co.	James Williams, Secretary, Derby	4
Bristol—Goods Depot at St. Philip's	Midland Railway Co.	James Williams, Secretary, Derby	4
Woodville and Swadhincoote—Station Buildings, &c.	Midland Railway Co.	James Williams, Secretary, Derby	4
Spondon, Borrowash-Draycott, Sawley, Sawley Junction Sheet Stores, and Trent—Station Buildings, &c.	Midland Railway Co.	James Williams, Secretary, Derby	4
Stafford—Repainting Exterior of County Asylum		Walter H. Cheadle, County Surveyor, Stafford	19
Nottingham—Cleaning and Decoration of Bulwell Wesleyan Chapel		Arthur Marshall, A.R.I.B.A., Architect, King-street, Nottingham	—
Ashton-under-Lyne—Painting, Papering, and Decorating 14 Houses		S. Wilkinson, 65, Whiteacre-road, Ashton	—

PLUMBING AND GLAZING.

Llanfyllin—Glazing Market Hall	Town Council	W. A. Pugh, Town Clerk, Llanfyllin	Feb. 22
Belfast—Glazing Goods Warehouse Roof (3,212sq.ft.)	Gt. Northern Rly. Co. (Ireland)	T. Morrison, Secretary, Amiens-street Terminus, Dublin	22
Whitehead—Plumbing Work at Villa	D. J. Lannigan	Thomas Pentland, Architect, 35, High-street, Belfast	—

ROADS AND STREETS.

Moss Side—Paving and Sewering Florence-street	Urban District Council	H. T. Crofton, Clerk, Moss-lane East	Feb. 19
London, E.—Wood-Paving at Infirmary, Bancroft-road	Midland Railway Co.	William Thacker, Clerk to Guardians, Bancroft-road, London, E.	21
Watford—Street Works	Urban District Council	The Engineer's Office, 14, High-street, Watford	29
Bewick—Repairs of District Roads for One Year	R.D.C. of Northam and Islandshires	H. Alder Peters, Clerk, 36, Ravensdowne, Berwick	24
Widlington—Street Works	Urban District Council	Albert Roberts, Clerk, Town Hall, Widlington	24
Bradfield—Repair of Roads	Bradfield Rural District Council	John Forrester, District Surveyor, Theale, near Reading	24
Pentre—Road and Sewer Works	Rhondda Urban District Council	W. J. Jones, Surveyor, Council Offices, Pentre, R.S.O.	24
Walthamstow—Construction of Roads, Higham Hill		Wm. Houghton, Surveyor, 58, Old Broad-street, E.C.	28
Cambridge—Roads and Sewers, &c., for St. John's College		J. Carter Jonas and Sons, Market-hill, Cambridge	—
Burslem—Forming New Street		Chatterley-Whitfield Collieries, Limited, Tunstall	—
Harrow—Forming Roads, Greenhill Park Estate		A. Sykes, Architect, 45, Finsbury-pavement, London, E.C.	—
Nuneaton—New Street (700 yards)		S. P. Stewart, Estate Office, Arbury, Nuneaton	—

SANITARY.

Denholme—Brickwork Culvert	Urban District Council	W. B. Woodhead and Son, Civil Engineers, 18, Exchange, Bradford	Feb. 21
Ruddington—Sewerage Works	Basford Rural District Council	C. J. Spencer, Clerk, Public Offices, Nottingham-road, Basford	21
Hunslet—Sewerage Works	Rural District Council	B. Pinder, Clerk, Leek-street Hunslet	25
Tirlemont—Sewerage Works (estimated cost, £24,000)		Secretariat Communal, Tirlemont, Belgium	Mar. 15
Bradford—Water Closets, &c., to 12 Houses, Manchester-road		H. Hardaker, Archt., Ivegate Chambers, New Ivegate, Bradford	—

STEEL AND IRON.

London, S.W.—Steel Rails (12,780 tons), Fishplates (1,250 tons)		Agent-General for Victoria, 15, Victoria-street, London, S.W.	Feb. 21
Bristol—Arc Lamposts (214)		H. Faraday Proctor, City Electrical Engineer, Temple Back, Bristol	21
India Office, S.W.—Steel Sleepers, Steel Laminated Springs, Cast-Iron Axle-Boxes, and Covered Goods Waggons		Director-General of Stores, India Office, Whitehall, S.W.	22
Birmingham—Welded Steel Pipes (6,000 tons)	Corporation	E. Orford Smith, Town Clerk, Council House, Birmingham	28
Ashby-de-la-Zouch—Cast-Iron Mains throughout Streets	Urban Council	W. A. Musson, Clerk, Ashby-de-la-Zouch	Mar. 1
Hereford—Bridge over Wye, Castle Green	Victoria Bridge Committee	J. Parker, C.E., Mansion, House, Hereford	10
Carlisle—3in. Cast-Iron Pipes (670 lineal yards)	Corporation	Henry C. Marks, A.M.I.C.E., City Surveyor, 36, Fisher-st., Carlisle	—

STORES.

Bedford—Road Materials	Bedfordshire County Council	The County Surveyor, Shire Hall, Bedford	Feb. 19
Sale—Road Materials, &c. (One Year)	Urban District Council	A. G. McBeath, A.M.I.C.E., Engineer, District Council Offices, Sale	21
Glasgow—Building Stone, Iron Castings, Larch Fencing, Lime, and Portland Cement	Glasgow and South-Western Ry. Co.	F. H. Gillies, Secretary, St. Enoch Station, Glasgow	21
Pontycymer—Red Bricks (350,000)	Corporation	The Secretary, Ffaldam Collieries Co., Cardiff	23
Rawtenstall—Road Materials (12 months)	Nottingham County Council	Town Clerk's Office, Rawtenstall	24
Nottingham—Granite, Slag, and Limestone (Six Months)	Norfolk County Council	E. Furnell Hooley, Shire Hall, Nottingham	24
Thorpe Asylum—Builders' Materials (One Year)	Urban District Council	G. Smith, Clerk of Works, Thorpe Asylum, Norwich	25
Norden—Road Materials (One Year)	Rural District Council	J. W. Sunderland, Surveyor, Church View, Norden	28
Thame (Oxon)—Broken Granite (1,640 tons)		William Parker, Clerk, 18, Corn Market, Thame	28
Wakefield—Broken Granite (3,960 tons), Broken Furnace Slag (10,350 tons)	Wakefield Rural District Council	H. Beaumont, Clerk, Tetley House, 47, Kirkgate, Wakefield	Mar. 1
Barnes—Road Materials (12 months)	Sanitary Committee	H. Bruce Tomes, Surveyor, Council Offices, High-st., Mortlake, S.W.	7
Bath—Sewer Pipes, &c. (One or Three Years)	Rural District Council	Chas. E. Fortune, City Surveyor, Guildhall, Bath	8
St. Thomas (near Exeter)—Road Materials (One Year)	Rural District Council	Robt. C. Cordon, Surveyor, Hazelwood, Derby	9
Sleaford—Gravel and Sand (1,500 tons), Unbroken Limestone (1,000 tons), Broken Limestone (1,500 tons), and Broken Syenite (6,000 tons), for Road Metal	Urban District Council	Arthur E. Ward, 9, Bedford-circus, Exeter	14
	Swansea Town Council	Edmund Clements, Clerk, Council Offices, Sleaford	26
		Borough Surveyor, 13, Somerset-place, Swansea	—





**BILLS OF QUANTITIES, PLANS, &c.**  
Lithographed in best style and with great expedition by  
**PARTRIDGE & COOPER,**  
ARCHITECTS' AND SURVEYORS' LITHOGRAPHERS,  
191 & 192, Fleet St., and 1 & 2, Chancery Lane,  
London, E.C.  
Special Prices quoted for Large Jobs.  
LIBERAL DISCOUNTS ACCORDING TO ARRANGEMENT.

**PILKINGTON & CO.**  
(ESTABLISHED 1838),  
MONUMENT CHAMBERS,  
KING WILLIAM STREET, LONDON, E.C.

Registered Trade Mark:  
**POLONCEAU ASPHALTE**  
Patent Asphalte and Felt Roofing.  
ACID-RESISTING ASPHALTE.  
WHITE SILICA PAVING.  
**SEYSEL ASPHALTE.**

**HAM HILL STONE.**  
**DOULTING STONE.**  
**THE HAM HILL & DOULTING**  
**STONE CO.**

Incorporating THE HAM HILL STONE CO. and C. TRASK and  
SONS (THE DOULTING STONE CO.)  
Chief Office: NORTON, STOKE-UNDER-HAM, SOMERSET.  
London Agent: Mr. E. A. WILLIAMS, 16, CRAVEN STREET, STRAND.

**FAMBRINI & DANIELS,**  
MANUFACTURERS OF IMPERISHABLE CONCRETE  
MASONRY FOR  
**CORNICES, STRING-COURSES,**  
**MODELLED PANELS, AND EVERY**  
**STONE-WORK REQUISITE.**  
LANDINGS and Plain or Moulded and Mitre  
STEPS, durable throughout.  
WORKS AND OFFICES: LINCOLN.

**WM. OLIVER & SONS,**  
MAHOGANY, WAINSCOT, WALNUT,  
TEAK, VENEER, and FANCY WOOD  
MERCHANTS,  
120, BUNHILL ROW, LONDON, E.C.  
The most extensive Stock of every kind of  
Wood in Planks and Boards, dry and fit for  
immediate use.

**TENDERS.**  
\* \* Correspondents would in all cases oblige by giving  
the addresses of the parties tendering—at any rate, of the  
accepted tender: it adds to the value of the information.

BLACKWOOD, N.B.—For the construction of a line from  
Blackwood to Lesmahagon, for the Caledonian Railway  
Company:—  
Pirie, G., Aberdeen (accepted) about £8,000.

DUDLEY.—For alterations and extensions to No. 20,  
Inhedge, Wolverhampton-street, Dudley, for Miss Robin-  
son. Messrs. John G. Wright and Son, 25, Wolverhamp-  
ton-street, Dudley, architects:—  
Webb and Round ... .. £133 10 0  
Edwards, J. ... .. 120 0 0  
Jakeman and Round (accepted) ... 110 0 0  
All of Dudley.

EAST WESTMORELAND.—For Bleatarn water supply, for  
rural district council. Messrs. George Watson and Son,  
Penrith, engineers:—  
Scott and Dent, Appleby ... .. £398 0 4  
Bowerbank, J., Penrith ... .. 369 10 0  
Taylor, W., Waitby ... .. 359 0 0  
Jackson, J., Penrith ... .. 354 0 0  
Scott, J. & W., Penrith (accepted) 345 0 0

HADLEIGH, SUFFOLK.—For the supply of fire-hose and  
apparatus, for the urban district council:—  
Salter, A. W. ... .. £62 10 0  
Graham and Joslin ... .. 58 7 6  
Firmin and Co. (accepted) ... .. 57 14 3

GOSPORT.—For factory at Gosport, for Messrs. C.  
Mumby and Co. Mr. W. H. Fry, Gosport, architect:—  
Lear ... .. £1,495 0 0  
Light ... .. 1,475 0 0  
Corke ... .. 1,422 0 0  
Crockerell ... .. 1,400 0 0  
Dash ... .. 1,389 0 0  
Jones (accepted) ... .. 1,350 0 0

HIGHGATE.—For the erection of new infirmary, &c., at  
Highgate Hill, N., for the Guardians of the Poor of St.  
Mary, Islington. Mr. W. M. Smith, A.R.I.B.A., 65,  
Chancery-lane, W.C., architect. Quantities by Mr. H.  
Dow White, 52, Finsbury-pavement, E.C.:—  
A. ... .. £203,045 ... £4,640  
Gough, F., and Co. ... .. 201,474 ... 4,937  
Patman and Fotheringham ... .. 189,707 ... 4,486  
Leslie and Co. ... .. 198,450 ... 4,500  
Chessum and Sons ... .. 197,462 ... 4,760  
Martin, H. ... .. 195,547 ... 6,315  
Patrick, J., and M. ... .. 195,000 ... 4,300  
Wall, C. ... .. 186,500 ... 5,063  
Gray Hill, C. ... .. 181,523 ... 4,269  
Kirk and Randall (accepted) ... ..  
A.—Extra for white glazed bricks above dado.

HORTON, NEAR EPSOM.—For alterations to the Manor  
House, including the erection of boiler-house, chimney,  
and two lodges, and for the erection of temporary build-  
ings, for the London County Council:—

Erection of temporary buildings:—  
Keay, E. C. and J. ... .. £77,798 0 0  
Gough, F., and Co. ... .. 72,897 0 0  
Harbrow, W. ... .. 70,459 0 0  
Hawkins and Co. ... .. 68,762 11 1  
Kirk and Randall ... .. 68,000 0 0  
Humphreys, Ltd. ... .. 66,556 0 0  
Leslie and Co. (accepted) ... .. 64,263 0 0  
Alterations and additions to Manor House:—  
Leslie and Co. ... .. 22,429 0 0  
Harbrow, W. ... .. 21,711 0 0  
Kirk and Randall (accepted) ... .. 20,812 0 0

KEYHAM, DEVONPORT.—For the enlargement of the  
Seaman's Barracks, for the Lords of the Admiralty:—  
Debnam, A. R., Mount Pleasant,  
Plymouth (accepted) ... about £200,000 0 0

LEEDS.—For carrying-out the excavations, masons',  
and bricklayers' work at the new meat market, for the  
city council:—  
Wright, A. J. (accepted) ... .. £2,543 0 0  
[In lieu of tender from Gould, originally recommended  
for acceptance at £2,763.]

LIVERPOOL.—For painting and decorating the rooms on  
the upper floor of the Town Hall, for the corporation:—  
White, A. Duke-st., Liverpool ... £3,998 12 9  
(Recommended for acceptance.)

LIVERPOOL.—For the erection of a plinth and railing in  
Prince Alfred-road, for the corporation:—  
Dilworth, Isaac (accepted) ... .. £580 0 0

**HOMAN & RODGERS,**

ORIGINAL PATENTEES OF ALL GIRDERS **ENGINEERS,** FORMED OF JOISTS AND PLATES.  
CONSTRUCTIONAL STEEL SKELETON BUILDINGS (AMERICAN SYSTEM).  
FIRECLAY BRICK FLOORS, ALSO CONCRETE FIREPROOF FLOORS.  
USED IN OVER 2,000 BUILDINGS

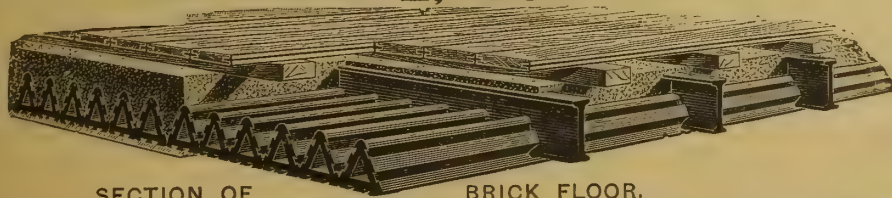

GRANITIC  
PAVING  
STEPS.  
ASPHALTE.

LONDON { OFFICES: 17, GRACECHURCH STREET, E.C. | MANCHESTER { OFFICES: 10, MARSDEN STREET.  
WORKS: NINE ELMS LANE, S.W. | WORKS: WEST GORTON.  
Telegraphic Address, "HOMAN RODGERS, LONDON." Telephone No. 1026 Avenue. | Telegraphic Address: "NAMOR, MANCHESTER." Telephone No. 637.

FIRECLAY BRICK WORKS:—PARKSTONE, DORSET.

WE ARE THE  
ORIGINAL  
INTRODUCERS  
OF THE  
HOT-WATER  
CYLINDRICAL  
TANKS.



ILLUSTRATED  
SHEET,  
SHOWING  
APPLICATION  
OF OUR  
HOT-WATER  
CYLINDRICAL  
TANKS, SENT  
ON REQUEST.

FITZROY WORKS  
352 to 364 EUSTON R<sup>d</sup>  
**LONDON,**

AND AT LIVERPOOL, GLASGOW, DEPTFORD, AND BRISTOL.

LONDON.—For pulling down and rebuilding the George the Fourth p.h., Portugal-street, Clare Market, W.C., for Messrs. Hoare and Co. Messrs. Reed and Perry, 9, John-street, Adelphi, W.C., architects :—  
 Dove Bros. ... .. £8,325 0 0  
 Knight, H., and Son ... .. 8,295 0 0  
 Hall, Beddall, and Co. ... .. 8,242 0 0  
 Holloway Bros. ... .. 8,176 0 0  
 Clarke and Bracey ... .. 8,028 0 0  
 Perry and Co. ... .. 7,740 0 0  
 Fatman and Fotheringham ... .. 7,440 0 0

LONDON.—For various works at the under-mentioned schools for the London School Board :—  
 Jessop-road School—Providing teachers' closets outside building and reconnecting existing closets to children's offices, and providing drainage :—  
 Garratt, J., and Son ... .. £1,935 0 0  
 Castle, W. and H. ... .. 1,927 0 0  
 Johnson and Co. ... .. 1,289 16 0  
 Higgs, F. and H. F. ... .. 1,269 0 0  
 Bowyer, J. and C. ... .. 1,258 0 0  
 Goad, W. V. ... .. 1,241 0 0  
 Maxwell Bros., Ltd. ... .. 1,219 0 0  
 Parker, G. ... .. 1,180 0 0  
 Akers, W. and Co.\* ... .. 1,118 0 0

Canterbury-road School—Providing infants' cloakroom, additional lavatory accommodation, and skylights in classrooms :—  
 Ford, J. F. ... .. £629 0 0  
 Goad, W. V. ... .. 625 0 0  
 Hammond, W. ... .. 573 0 0  
 Triggs, E. ... .. 554 19 0  
 Line, H. ... .. 465 0 0  
 Jones and Groves ... .. 449 0 0  
 Lenev, H. ... .. 447 0 0  
 Rice and Son\* ... .. 439 0 0

Albion-street School—Inclosing, draining, and tar-paving the additional land :—  
 Williams, R. E., and Sons ... .. £930 0 0  
 Johnson and Co. ... .. 650 0 0  
 Ford, J. F. ... .. 648 0 0  
 Marsland, J. ... .. 485 0 0  
 Line, H.\* ... .. 419 0 0

Weston-street School—For providing and fixing a partition to divide large room in girls' department :—  
 Brittain, G. ... .. £139 0 0  
 Musgrove, S. ... .. 138 14 0  
 Oldman, J. and A. ... .. 92 10 0  
 Tucker, E. B. ... .. 88 19 0  
 Wake and Dean ... .. 88 0 0  
 Line, H.\* ... .. 79 0 0

Lant-street School—Providing and fixing hot-water coil in infants' class-room and fixing tubular boiler :—  
 Cannon, W. G., and Sons ... .. £42 0 0  
 Grundy, J. ... .. 36 9 0  
 Ellis, J. C. and J. S., Ltd. ... .. 34 10 0  
 Davis, G. ... .. 32 0 0  
 Berry, Campbell, and Co.\* ... .. 28 10 0

Edinburgh-road—Providing and fixing hot-water coils in corridors, and fixing tubular boilers :—  
 Rosser and Russell, Ltd. ... .. £107 5 0  
 May, J. and F. ... .. 106 0 0  
 Gray, J. ... .. 99 0 0  
 Vaughan and Brown, Ltd. ... .. 92 0 0  
 Comyn Ching and Co. ... .. 88 10 0  
 Wontner-Smith, J., Gray, and Co. ... .. 78 18 0  
 Davis, G. ... .. 70 0 0  
 Grundy, J.\* ... .. 64 7 0

Dalglish-street School—Providing and fixing hot-water coils in corridors (boys', girls', and infants') and in one classroom (boys' and girls' respectively) and two classrooms (infants') and fixing tubular boilers :—  
 Ellis, J. C. and J. E., Ltd. ... .. £149 10 0  
 Gray, J. ... .. 149 0 0  
 Comyn Ching and Co. ... .. 134 10 0  
 Defries, J., and Sons, Ltd. ... .. 130 0 0  
 Strode and Co. ... .. 130 0 0  
 Fraser, J., and Son ... .. 109 0 0  
 Simmons, W. ... .. 107 15 0  
 Cooper, W. J.\* ... .. 101 0 0

Weston-street School—Providing and fixing hot-water coils, and fixing S.B. stoves in two large classrooms (boys') and one large classroom (girls'), and fixing tubular boilers; fixing S.B. stoves in one large classroom (infants') :—  
 May, J. and F. ... .. £120 0 0  
 Rosser and Russell, Ltd. ... .. 112 10 0  
 Ellis, J. C. and J. S., Ltd. ... .. 109 10 0  
 Defries, J., and Sons, Ltd. ... .. 101 10 0  
 Strode and Co. ... .. 97 0 0  
 Strong and Collings ... .. 79 0 0  
 Clarke, J. F., and Sons\* ... .. 78 15 0

Royal Normal College—Repairs to buildings, &c., on a running contract :—  
 On schedule prices for repairs.  
 Akers, W., and Co. ... .. + 20 per cent.  
 Bowyer, J. and C. ... .. + 20  
 Garnham, J., and Son ... .. + 20  
 Stewart, J. ... .. + 15  
 Lenev, H. ... .. + 12½  
 Poole, W., and Son ... .. + 12½

Supply of English eight-day dial clocks on a running contract :—  
 Warren, R. J. ... .. each £2 9 6  
 Benson, J. W., Ltd. ... .. 2 7 6  
 Bowley, J. ... .. 2 5 0  
 Monks, W. H. ... .. 2 2 0  
 Sainsbury, W. A. ... .. 2 2 0  
 Meader, J. ... .. 2 0 0  
 Stockall and Sons\* ... .. 1 15 0  
 \* Recommended for acceptance.

Burdett-road Congregational Church School—Adapting premises for a temporary school :—  
 Holliday, J. F. ... .. £505 0 0  
 Kybett, J. ... .. 492 0 0  
 Barker, G. ... .. 464 0 0  
 Jackson, T. H. ... .. 459 0 0  
 Symes, A. E. ... .. 428 0 0  
 Robey, J. T. ... .. 421 0 0  
 Gibb, D., and Co.\* ... .. 409 0 0

Harwood-road School—Infants': Fixing tubular boilers and four large S.B. stove fronts. Boys': Fixing four large S.B. stove fronts :—  
 Comyn Ching and Co. ... .. £153 10 0  
 Wontner-Smith, J., Gray, and Co. ... .. 109 15 0  
 Cannon, W. G., and Sons ... .. 98 15 0  
 Defries, J., and Sons, Ltd. ... .. 96 0 0  
 Clarke, J. F., and Sons ... .. 91 0 0  
 Stevens and Sons\* ... .. 82 5 0

LONDON.—For sundry alterations to 15, Castle-street, E.C. for Mr. Chas. Parkin. Mr. C. R. Winter, architect :—  
 Jarvis and Son ... .. £314 0 0  
 Battley, J. R. ... .. 298 0 0  
 Harborow ... .. 257 0 0  
 Irwin, W. ... .. 247 0 0

LONDON.—For the reconstruction of drainage and other sanitary works at the infirmary, St. John's Hill, S.W., for the Guardians of the Poor of the Wandsworth and Clapham Union. Mr. Thos. W. Aldwinckle, F.R.I.B.A., architect. Quantities by Mr. Bernard Swinstead :—

Aries, S.W., and Co. ... .. £6,826 0 0  
 Garrett and Son ... .. 5,349 0 0  
 Roome, E. A. ... .. 5,134 0 0  
 Wall, H., and Co. ... .. 5,125 0 0  
 Johnson, W., and Co. ... .. 4,975 0 0  
 McNeil, D. ... .. 4,766 0 0  
 Beattie, R. P. ... .. 4,675 0 0  
 Bostel, D. T., and Sons ... .. 4,675 0 0  
 Gardner and Hazell ... .. 4,492 0 0  
 Barrett and Power ... .. 4,489 0 0  
 Roffey, H. (accepted) ... .. 4,200 0 0  
 Flemming, J., and Co., ... .. 3,761 0 0  
 Knight, J., and Sons ... .. 3,730 0 0

LONDON.—For the erection of a block of flats (Block 1) at Sloane-court, Chelsea, S.W. Mr. Paul Hoffmann, 152 and 153, Palmerston-buildings, Old Broad-street, E.C., architect. Quantities by Messrs. Dunk and Bousfield, Billiter Square-buildings, E.C. :—  
 Allen, J., and Son ... .. £18,950 0 0  
 Britton, F. ... .. 18,900 0 0  
 Kearley, C. F. ... .. 18,610 0 0  
 Grover, J., and Sons (accepted) ... .. 18,178 0 0

MAIDSTONE.—For building a coal-store at the sewage works, for the corporation :—  
 Burrows, W. T. (accepted) ... .. £81 15 0  
 (Lowest tender received.)

# THOROUGHLY DRY.

WAINSCOT.  
 MAHOGANY.  
 WALNUT.  
 TEAK.

AND OTHER HARDWOODS.

PITCH PINE.  
 YELLOW PINE.  
 JOINERS' DEALS.

# WAINSCOT, TEAK, & PITCH PINE FLOORING.



COMMON-SENSE  
 JOINT  
 RECOMMENDED.



WM. OLIVER & SONS, 120, BUNHILL ROW,  
 LONDON, E.C.

# TESTED STONWARE PIPES. KNOWLES' PATENT JOINTS. STONWARE. JOHN KNOWLES & CO., Manufacturers.

Dépôts at Star Wharf, Regent's Canal, King's Road, St. Pancras, N.W.; M. Ry. Goods Stns., St. Pancras, and Child's Hill and Cricklewood, N.W.; J. & N. W. Ry. Goods Stn., Old Ford, Bow, E.; N. L. Ry. Goods Stn., Hammersmith and Chiswick, W.; L. & S. W. Ry. Sta., Twickenham; G. N. Ry. Stn., Palmer's Green, Southgate, N. Knight's Hill Station (L. B. & S. C. Ry. and L. & N. W. Ry.), Dulwich, S.E.; Bromley, L. C. & D. Ry.  
 Goods delivered by Vans to any Part of London. ILLUSTRATED PRICE LISTS ON APPLICATION.  
 Works: Wooden Box, Burton-on-Trent. Sheffield: 35, Green Lane. Nottingham: Brougham Chambers, Wheeler Gate, Glasgow: 37, West George Street.  
 Chief London Office: 38, KING'S ROAD, ST. PANCRAS, N.W.  
 Telegraphic Addresses:—London Office, "JOHN KNOWLES, LONDON." Works Office, "KNOWLES, WOODVILLE." London Telephone No. 7587.

## THE BUILDING NEWS

AND ENGINEERING JOURNAL.

VOL. LXXIV.—No. 2251.

FRIDAY, FEBRUARY 25, 1898.

## MODEL SPECIFICATIONS.—I.

WE propose, at the suggestion of several correspondents, to take up the subject of specifications—one that, from various causes, has been much neglected by architects. The very few books that have appeared on the subject have dealt with specifications in a more or less general and formal manner, or have been deficient in many items of modern requirements. They have, therefore, been of scarcely any use except as mere outlines. Two or three admirable works have appeared dealing with the subject in the form of items, data, or "notes," two of which have appeared in the *BUILDING NEWS* in a series of articles; but, as far as we know, the student and architect of to-day are without any complete set of model clauses. There are three methods of treating the subject, which we may call A, B, and C. Method A.—Taking a given building of a particular kind, and describing the work *seriatim* trade by trade. Method B.—Taking the trades in rotation, and giving clauses for ordinary and superior qualities of work. Method C.—Giving model or typical clauses for special kinds of work. There are advantages in each method. The first plan can only be of service when the building described is "on all fours" with the one proposed to be erected. A set of clauses for a small villa, for instance, would be of no value as a guide for a specification for municipal offices or a shop. As a skeleton outline it may be of some service, but for general application to other buildings it has no value. The young practitioner is chiefly in want of a carefully-compiled and comprehensive series of items or clauses as an aid to the memory, and which he may be able to adapt to the particular work he has in hand. He wants to know, in short, what and how to specify—in other words, specimen clauses for the principal kinds of work in each trade, adapted to different classes of building. Perhaps it may be a clause for the drainage of a building, or a brickwork clause. If he can find one that can be easily adapted by a few minor changes—as, e.g., sizes of pipes or qualities of brick—it is of value. If, for example, his design shows a quantity of rubbed red brickwork in reveals and arches cut and gauged, it will be of assistance to him to find suitable clauses. Or he may want a clause describing an underground reservoir, or the mode of constructing a waterproof cellar, or a good clause for half-timber work or tile hanging; in each of these cases he is anxious to meet with a clause that will express his requirements within a little. For these reasons we think the methods B and C are of more essential use to him, and we therefore intend in these articles to follow those modes of dealing with the subject. We shall fill in the materials and sizes where it may be necessary to do so as a guide, adopting in preference those which are used in the best work; and we shall give, when necessary, alternative clauses, or insert the substitutes in brackets. In the matter of timber scantlings and stone details, of course, every building must be studied by itself, so that any dimensions given may be misleading.

In covering so large a ground, embracing as it does all the trades connected with building. It will be impossible to deal with every item or condition that may occur in practice; nor do we pretend to be infallible in our methods or opinions. Our object is not

to write a treatise of construction, or to supply data on materials and scantlings which are dealt with in detail by other treatises; but rather to frame, unhampered by convention, or ordinary usage, clauses that may be taken as specimens or models for ordinary building requirements, omitting matters that have only reference to special circumstances, and confining our attention to those leading requirements applicable to most buildings. We shall probably not please everybody; but we shall be glad to receive from practical correspondents any suggestions they are willing to offer.

Specifications vary greatly in their matter and form;—every architect has his own formula, and in different localities we find many diverse uses. The chief want of the architect is a series of forms for clauses that will embody his requirements in a clear and concise manner. A verbose clause is often ambiguous, or its punctuation is faulty, or the sentence may be so involved that the builder or contractor interprets it in a sense that is not intended, or evasively turns the circumlocution to his own advantage. A short one is often so general as to be of no use whatever. Between verbosity and extreme brevity, the architect requires to make a choice, so that definition and clearness be both attained. There is another point. We require to choose between a "cut and dried" form, with its set formula of words, and that vague and incoherent composition so tiresome to practical men. The former often lacks meaning, the latter is tedious.

What should a specification comprise? A good principle to guide the specification writer is to make it embody every detail and item about which the drawings give no information or are obscure thereon. One ought to throw light on the other. As a rule it is very far from doing so, and perhaps the worst thing for the young practitioner to do is to follow the drawings too closely. It is better for him to think and reflect, to revolve in his mind what is necessary on this floor and on that, in this room and the other, and to take up a bill of quantities to refresh his memory. Mr. Leaning's little book on specifications will be a help in this direction. Numerous items like special window and door frames, sound-boarding, stoves, glazing, &c., often go undescribed if a regular course is not pursued. Many specifications are commenced when the general drawings only are ready, the consequence being that important details are overlooked; but if the details are prepared as they should be, greater brevity is insured, as the details can be referred to. These may be numbered or slightly sketched in margin. If when the drawings are being prepared notes are made during their preparation of anything that occurs to the architect, much trouble in these matters would be saved. In writing a specification, begin either at the top or bottom of the building—the latter preferably, and maintain the same order. It is necessary also to observe an order or sequence in every trade, as it assists the memory, and helps to avoid omissions. Thus, in describing such trades as joinery, it is advisable to adopt some order, as floors, skirtings, windows, doors; those of deal first, afterwards those in oak or other hard wood. In describing sashes, their thickness, section of bar, linings; or in doors, the number of panels, the thickness of framing, if plain or moulded on one or both sides, how hung, what linings, &c.

There are some who think the specification should be given to the surveyor to write. Mr. Leaning, in his excellent work on "Quantity Surveying," says: "It is an advantage to have the specification written by the man who takes off the quantities; he checks his own work thereby, and it is better completed before the quantities are lithographed, so that any errors therein may be

corrected." From an architect's point of view, this opinion is open to question. If the specification is merely to be regarded as a means of contracting or tendering, or as simply to guide the quantity surveyor, then, of course, there could be no objection to the arrangement; but if the specification is to be regarded as an architect's document, only second to the plans and drawings, descriptive of his intentions and supplementary to them, it should always be prepared by the architect. No doubt it is a desirable plan that the architect should submit the specification to the surveyor for amendment or correction before the quantities are prepared, and sometimes a meeting is convened between them to go through the items for this purpose.

We do not propose to give a form of general conditions, as circumstances vary so much that the architect is the best judge in each case of the particular conditions required, and the Institute "Schedule of Conditions" gives a very complete list of conditions that may be varied to suit special cases; but it may be useful to enumerate certain preliminary conditions which apply to most cases, and we may name these under the general head of

## PRELIMINARY.

1. At this early stage the architect should prepare a plan of the site, with the datum level and other particulars. The levels of ground should be carefully taken before the plans or specifications are prepared; thereby much uncertainty as to the depth of footings, drainage, and other matters are avoided. Inattention to this often leads to serious misunderstandings between contractor and architect, and to great divergences in the tendering, especially as to the Excavator and Bricklayer's work. In most specifications we have seen, the Excavator's work has been very vaguely described as to the depth of excavation, the soil to be removed or the distance it is to be carried. But this information cannot be given unless levels are taken over the site, and these are marked in clear figures, say red or blue, on the site plan. In some cases, as when the ground is irregular, sections are necessary, showing the original levels and those which are required at the completion. When architects begin to realise more than they do now the value of laying out the site and surroundings of their buildings, they will take more pains in specifying where the excavated material is to be placed; if any depressions and cavities in the ground are to be filled up, and if a terrace on one or more sides of the building is to be formed.

2. Before tendering it is necessary that the contractor should make himself acquainted with the site, and by the aid of the levels and plan, see what is required to be done. Drainage of site and superfluous water must also be considered.

3. In town sites, it is necessary to inclose the site with a post-and-rail fence or a hoarding, allowing for cart entrances, and plank footways, in accordance with the regulations of the local authority or vestry.

4. In the building or alteration of street premises, the question of shoring the party and external walls, floors, and roofs has to be considered, and the requirements of the London Building Act (1894), especially the sections relating to lines of building frontage (Part III. section 22, &c.), to dangerous structures (section 102, *et seq.*); to additions to and alterations (sections 207-211, &c.), or to provisions in the by-laws under the Public Health Act, 1875, have to be taken into account, also the rights of adjoining owners.

5. The old materials of any existing building to be removed; the cleaning, stacking, and re-use of old bricks.

6. When there are no dimensions given in the plans or drawings, the architect is to have the power to decide the same, and

should there be any omission in the specification the contractor is to call the attention of the architect to it, and, in any case, supply what is necessary.

7. It is necessary also for the contractor to consider the water supply, the carriage, plant, pumping, and other appliances the machinery, hoisting, travelling expenses, lodging, and other requirements of his men.

8. Lighting is often an item of consideration in some cases. In foundation work, where constant pumping is necessary, or in completion of short-time contracts, gas or electric lighting may be necessary.

9. The removal of rubbish from site before the excavations can be commenced; storage of materials under cover like lime and facing bricks; sheds for the same; clerk of works' office, and other temporary fittings, have to be considered.

There are many preliminary clauses which ought to be inserted before the specification of trades, and which apply to all. One of these relates to the attendance of one trade on all the others. Thus the joiner is expected to attend on bellhanger, and to make good after him, to cut away for pipes, and to make necessary casings after plumber's work; the plasterer also has to make good after plumbers, bell-fitters, gas-fitters, &c. In alteration, or in the demolition of an old building such a clause as this may be necessary:—"Inclose by proper boarding the adjoining premises, and carefully shore up and support the roof and floors of house on the — side before removal of the party-wall, &c."

It is customary also to insert a clause mentioning any provisional sums to be made in any trade; as, for example:—

"Provide the sum of, say, £500 for heating apparatus. Provide the sum of £200 for stoves. Provide the sum of £1,000 for internal decorations, &c."

These sums are often expended as the architect may direct, or they are to be paid *net* to the tradesman selected on the architect's certificate, or the sum may be deducted from the contract. The contractor is to render all facilities, scaffolding, &c., for the execution of these works; a provision for packing and carriage is to be allowed in each case. When these provisional sums are provided, the architect generally selects any special manufacturer or tradesman. When the contractor pays for them, a discount of 10 per cent. is allowed, this percentage being considered sufficient on these provisions.

#### THE DESIGN OF THEATRES.

THAT so little has been done to make our playhouses worthy of the drama and of the sites which they occupy is perhaps attributable to the same national indifference to art which finds frequent expression. The average Englishman is, it must be confessed, a very undemonstrative person, and his feeling for art or anything else artistic is to be measured more or less by the amount of profit or mere utility which may be made out of it. The "play-sense" has never been strong in him; he is naturally disinclined to favour anything that is sentimental or poetic, and in many other ways, whether in public or private, in ceremony, in ritual, in the æsthetic pleasures, he shows a marked *sang-froid*. But with the greater facilities of travel, the introduction of wider sympathies, and Continental ideas, the average Englishman is improving. Mr. Edwin O. Sachs, in his interesting paper on the "Housing of the Drama," which we reported in our last issue, points out what the individual holder, lessee, or manager desires—that it is, in short, a matter of pounds, shillings, and pence to him. He considers only the audience within the auditorium; comfortable seats upholstered "up to date";

gilding and paint. "The London manager has only to cater for the pleasure of a sensation-seeker practically devoid of any feeling for architecture and with little reverence for dramatic art." It is quite true, and it is this sort of ephemeral pleasure-for-the-moment craze that is studied. The great outside public who seldom enter theatres are not considered at all; the comfortable seat or box-holder is all that is catered for by the builder, and his or her taste for art or architecture is often only to be measured by the quantity of plush velvet or gilding that he obtains for his patronage. The consequence of this taste is not far to seek. We have practically no theatre in London, save perhaps the Palace, which is at all designed on architectural lines. Many of them are splendidly equipped and upholstered and decorated within; but we cannot point to one that is architecturally conceived, where the separate parts like the auditorium and stage and entrances are designed in reference to their functions, and are made to assume externally a building worthy of the English drama. The Shakespeare Memorial Theatre at Stratford-on-Avon is alone the one monumental building we have, and this was built by subscriptions. Many theatres, forsooth, are dirty squalid-looking exteriors, mere brick walls with a portico tacked on in front, or are so hampered and concealed by adjoining houses and shops, like most of those in the Strand and West End, that they cannot be dignified by the name of architecture at all. We enter a vestibule or crush-room of small dimensions, embellished by gilt and mirrors, and lighted by gas or the electric light, and then have to struggle through a dark unventilated passage till we enter our box or stall. Then the "glories" of the real building burst upon the view; it is indeed, after all, but a diminutive affair, but embellished with all sorts of manufactured articles—decorated plasterwork, paint, upholstery, and gilt. All is cased in plaster or shams of one sort or another—little solid work. A firm of decorators or upholsterers are engaged to turn out the whole thing; architecture ceases at the entrance. Nor can we wonder, if we take into account the tenure, the financial complications—in fact, the commercial basis of the London and provincial theatres. In most cases they are speculations; the buildings are leased, not erected for the ostensible purpose of providing a home for the drama. But the lack of architectural character is owing to the position assigned to the play. On the Continent, we find the Court subsidises the municipal and subscription theatres; the playhouse is regarded as educational and recreative in some Continental towns; in others, the building is presented and endowed by some wealthy citizen. Compare a building erected for dramatic representations in this manner, and another erected by a private individual as a commercial undertaking. The motives that prompt them are different; one is to produce a monumental building in which the Muses are enthroned. No expense is spared to produce a building that shall be an ornament to the site. The donor builds it, not as a commercial investment, but as a source of recreation under municipal management; the motive, not the profit, is the consideration. In the commercial undertaking the architect is cramped, the art is lost sight of, and the question is, What will pay? and the design is generally put in the hands of men who know something of the planning and working of theatres. Any architect who is the "run" with the theatrical profession, and can assist financially, is employed. He is generally within the "charmed circle," and the more he knows of the stage the better. Those who have read Mr. Darbyshire's book and his remarks on his own experience as one who has had to do with many theatres in Manchester and London will at once

appreciate this attitude. Then the essentially technical demands of theatre construction have to a large extent called for special experience, and have estranged the architect from this class of building. He has to be expert in planning of entrances and exits of different classes of the public; to be acquainted with the latest improvements in fireproof construction, in hydraulic and other appliances, lighting and other details—matters which it would take a lifetime almost to master. These are all conditions unfavourable to an architectural conception. It is curious indeed that buildings connected with our amusements and recreations are not worthy of better treatment. Anything is thought good enough in the shape of a building, and the most temporary structures are built for these uses, even for housing our national art collections at South Kensington.

One of the main weaknesses of our architectural work in this direction is the lack of relation between plan and external design. A good plan is often marred by a poor elevation or an exterior that would do bare justice to a factory or warehouse. We have nothing like the Court Theatre, Vienna, or the Paris Opera House to point to, where fenestration is made a conspicuous part of the exterior façades. Everything here is lavished on the proscenium boxes and the decoration of the interior. In the first of these the architects, one of whom was Gottfried Semper, aimed at expressing internal arrangement. It is true the site or surroundings of these buildings favoured the monumental style. Semper's great structure was based on the radial planning of the auditorium, and the graceful arrangement was the result, with its segmental grand vestibule and foyer. Here, as Mr. Sachs says, the exterior expressed every part of the interior planning. Buildings dedicated to the drama have in this country at least been designed with little reference to external effect. No doubt the situation of many of our London theatres has made it almost impossible to study more than one front. The late Mr. Phipps, in Her Majesty's Theatre, we lately illustrated, had the opportunity of doing something better, and the result is certainly a step in advance; but still there remains much to be done to make the buildings of the English opera and playhouse rank with those in other departments of our national architecture. Plan and external design must be studied together; the architect ought again to master the problem of planning, instead of relegating the duty to experts and decorators who are content to allow the exterior to remain as a mere shell or case of an elaborated, and often extravagantly embellished, nucleus.

#### TOP-LOADED BUILDINGS.

THE terrible disaster which befell a political meeting at London, Ontario, recently recorded, and which caused the deaths of twenty-two persons and serious injury to a hundred others, comes as another warning to architects and projectors of public buildings. A crowded meeting had been held at the City Hall, followed by a *conversazione*. From the reports published, it appears the floor gave way, precipitating upwards of 200 persons on to the floor beneath, which, in its turn, gave way, landing the mass of the assembly in the cellar. To add to the horror of the situation, and to the injuries inflicted on the hapless crowd, an immense safe fell amongst them, as well as a heavy steam coil. What could have been more disastrous and appalling? From the evidence of the city engineer, a heavy compound beam below the floor gave way, and it is stated the beam was composed of "twelve timbers each 3in. by 4in. securely jointed together." It broke in the middle, rolling all the people on this part of the floor into one mass. The

engineer states that he did not consider the hall was dangerous, but the great weight of the enormous crowd caused the beam to break.

Till the case has been thoroughly investigated, it would be unwise to attach blame to anyone in particular, or to draw any definite conclusions as to the cause of the catastrophe; but, at the same time, the question will at once occur to the practical mind,—“Why so large a crowd of people should have been allowed to assemble in a room two stories high without additional precautions having been taken?” Even so simple a thing as a stout post or baulk resting on a plank on the lower floor, and supporting the beam somewhere about its centre, would, in all probability, have averted the disaster, as the load on the beam in such case would have been reduced by a fourth, as the strength varies inversely as the length of the beam. The load of the people on the beam was inferentially a distributed load, and we know experimentally that a beam can carry twice the load when equally diffused over it than it can if concentrated in the centre. Probably some sudden tread or stamping of the crowd caused the fracture; but of these details all must be conjecture. Possibly there was a defect in the material of the beam itself; or the parts of which it was built may not have been properly bolted together. The reports received are clearly incorrect as to the composition and size of the beam. One of these says the beam was composed of twelve timbers, each 3in. by 4in., which must be a mistake. The dimensions, 3in. by 4in., are absurd on the face of it for a solidly-built beam, but these particulars will shortly be known. The sizes of the timbers rather suggest a trussed beam of wood, in which case the size would be intelligible. The profession interested in these matters will be glad to know how the beam was constructed, and of what composed, and the immediate cause of collapse. But the sad fate of so large a number of people, their precipitation through two floors, suggests the more general inquiry why a city hall should be placed in such a position. We have always strongly objected, for several reasons—chiefly panic caused by fire, and want of means of escape—to assembly-rooms being placed on upper floors. We know the practice is common even in this country for the large hall of a municipal building to be placed on the first floor above the offices, so as to command a better or more prominent position in the elevation; but for the reasons we have named, we consider a public hall should be placed on the ground-floor level, if possible. To overweight a building on the top floor is always dangerous, and any vibration or sway of a crowd in such a position must involve greater risk on the construction by putting undue stress upon the floors and walls. Great loads anywhere in a lofty position are undesirable, for the simple reason that the centre of gravity is shifted from its natural position. As to the heavy safe and coil case which loaded the floor, inquiry also is demanded whether these had proper brick walls or piers to stand on; but we wait for information.

#### ROYAL INSTITUTE OF BRITISH ARCHITECTS.

An ordinary meeting of the Institute was held on Monday evening at 9, Conduit-street, W., Mr. H. Louis Florence, vice-president, in the chair. A paper, illustrated by numerous pen-and-ink drawings, executed by the author, was read by Mr. J. TAVENOR PERRY, Fellow, on

#### THE MEDIEVAL CAMPANILI OF ROME.

In his introductory remarks, after alluding to the references to these familiar towers in the works of Willis, Lockyer, and Papworth, Mr. Perry commented on the fact that so little was known of the history, or had been written about them, and urged the great necessity of some detailed record of them, since already many had dis-

appeared, and all were falling into a state of serious dilapidation. Having given a list of the campanili still standing, the author pointed out that tower building was a tradition of Roman Classical times, and mentioned those built by Pliny, Augustus, and Diocletian, and representations of those which have been found, particularly that on a ceiling discovered in the Farnesina gardens by Professor Lanciani. The first recorded erection of a bell-tower in Rome is that of St. Peter's, in the middle of the 8th century, which was restored by Leo III. a few years later. In giving an abstract of the principal events in Mediæval Roman history, as related by Gregorovius, an attempt was made to show that only during very limited periods were building operations possible in Rome, and that the most important of these was the time of Leo IV. after the repulse of the Saracens. The details of the construction and decoration of the towers were described in relation to their likeness to or divergence from Classic examples, particularly in reference to their arcades; and an attempt was made by a comparison between these and the windows of some English towers known as “Saxon” to establish the theory of their early date. Mr. Perry asked: “Whence did the Saxons derive their ideas on this subject? Not from the scanty vestiges of antiquity still remaining in the island, not from France or Germany, where such features were unknown; but from the only place where they could by any possibility exist—Rome itself. Alfred the Great, entering St. Peter's for the coronation of his father, Athelwulf, had before him the great campanile of Stephen and Leo, and, when leaving, from the steps of the atrium, he may have seen the campanile of St. Michele of the Saxons in the Borgo, much as we see it now.” A comparison was further made between the dated examples of towers both in North and South Italy, such as those of Milan, Amalfi, &c., with a view to show that the Roman examples were of an earlier date. The niches on some of the towers were described, and it was suggested that these were not intended for statues, but to shelter sacred paintings, of which great numbers reached Rome from Byzantium in the time of Leo the Iconoclast. The majolica decorations were mentioned as indications of date, those on SS. Giovanni e Paolo being assumed to be coeval with the tower, and painted for the position they occupy. In conclusion, an account was given of the state of dilapidation into which most of the campanili had fallen, and the damage which had been done to them by injudicious restoration or repair.

Mr. R. PHENE SPIERS, F.S.A., proposed, and Mr. H. H. STATHAM seconded, a vote of thanks to the lecturer. This was supported by Mr. WILLIAM WOODWARD, and was carried by acclamation. Mr. PERRY briefly replied.

#### BUILDERS' CLERKS' BENEVOLENT INSTITUTION.

THE thirty-first annual meeting of the donors and subscribers was held at the offices of the Institution, 21, New Bridge-street, E.C., on Tuesday evening, the president-elect, Mr. R. C. Foster (Messrs. Foster and Dicksee), occupying the chair, supported by Mr. Thomas Hall (retiring president), Mr. E. Brooks (treasurer), Messrs. E. B. Gammon, F. S. Oldham, H. W. Parker, C. K. Turpin, W. Seymour, E. C. Roe (son of the late lamented E. C. Roe), J. C. Amphlett, and other gentlemen. The secretary read the report, which stated that the amounts received in the past year were £271 8s. 6d. in subscriptions, £396 0s. 6d. in donations, £148 10s. in dividends, and £2 2s. 11d. as interest on deposit. There was also a balance from the dinner account of £8 16s. 5d., making a total for the year of £826 18s. 4d. The disbursements amounted to £506 12s. 6d., of which sum £418 8s. 4d. was given in pensions and temporary relief. There are twenty pensioners now on the books. Referring to the orphan fund, there is a vacancy at the present time, and the committee are prepared to receive applications on behalf of intending candidates. The nineteenth annual dinner was held in the King's Hall, Holborn Restaurant, on Tuesday, April 6th, 1897. The appeal made by Mr. Hall, the president, was most successful, the amount announced being £391 16s. 6d. The committee fully realised the value of Mr. Hall's services, not only in connection with the dinner, but for all he had done

throughout the year in helping forward the work of the institution. It being known that much distress existed amongst some of the pensioners, it was thought that a good way of celebrating the Queen's Diamond Jubilee would be to increase the amounts of the pensions—the men's being raised from £25 to £30 per annum, and the widows' from £20 to £24 per annum. The limit of income (apart from the pension) being extended from £25 to £35 per annum. The increase made was greatly appreciated by the pensioners. Referring to the presidency, the committee announce with pleasure that Mr. R. C. Foster has kindly accepted the office in succession to Mr. Hall. The committee concluded by thanking the professions and trades identified with the building interests for their continued support. The President-Elect, in moving the adoption of the report, remarked that he had been looking over the accounts; but it did not seem needful to say much about them, as “good wine needed no bush,” and as to the work done generally, as shown in the report, to say much in its praise would be like gilding the pill they were asked to swallow. The institution was to be congratulated on the success that had attended its operations since its establishment. There were now some things he would specially refer to. In the first place, the previous year's income had been the largest yet received, a fact to be noted. Then, again, looking at the income, and the expenses incurred, he noticed that of every twenty shillings received the expense of working amounted to 2s. 2d. only, leaving 17s. 10d. available for use along the fighting line, and it might be well if this could be followed by other societies. In looking through the list of previous presidents, he felt it to be quite a new departure in asking the representative of a country firm to become president of a London institution; but he hoped this would not matter. He might not have the chance of emulating the out-going president, Mr. Hall, but he hoped to do his best, and especially as he had a new field to travel. He had received valuable help from the secretary, and had done his best to digest the various documents that had been laid before him. He would conclude by moving the first resolution, to the effect that the report and balance sheet be adopted and printed, together with the list of subscribers and rules. Mr. E. B. Gammon seconded, and the resolution was duly carried. Mr. Brooks proposed, and Mr. Parker seconded, a vote of thanks to the retiring officers, which was carried. Mr. Thomas Hall, the retiring president, replied briefly, saying he had spent a very pleasant year, and was sorry it had come to an end, and thanked the officers for the help he had received during his presidency. On the motion of Mr. Oldham, seconded by Mr. Turpin, officers for the present year were elected, and the meeting closed with a hearty vote of thanks to Mr. Foster for his kindness in accepting the presidency, and his services in the chair.

#### EGYPT THE BIRTHPLACE OF ARCHITECTURE.\*

EGYPT is, so far as has been ascertained, the fountain-head of all civilised architecture, and being a country of peculiar climate, the remains of even the most ancient works have been handed down to us in a remarkable state of preservation, so that we are able to trace their history back in a manner which would have been otherwise impossible. Besides this, again, the monuments have been covered with inscriptions, both by those who erected them and by their successors, and modern research having enabled these inscriptions to be read, the history of the country and of the buildings alike has been revealed. So far as it has been possible to ascertain the facts, it appears that the generality of the people have been at all times agriculturists, subject to despotic and often foreign rulers, who have made them their slaves. Thus, whenever the throne has been occupied by those who have been inclined to build, there has been ample slave labour available, both for the actual erection of the buildings and for the transport of materials, to bring limestone from the hills bounding the Nile valley, or granite from Syens. The dates given by various authorities both to buildings and rulers are very confusing; but, according to Mariette, there were thirty different Dynasties of heathen Kings or Pharaohs between the years

\* Paper read by G. A. T. MIDDLETON before the Society of Architects last night (Feb. 24).

5004 B.C. and 378 B.C., divided into three great periods, thus:—

1st Period	Thinite and Memphite	1st to 16th Dynasties.
2nd Period	Thiban (Ancient)	12th to 17th Dynasties.
	Thiban (New)	18th to 21st Dynasties.
3rd Period	Saïte (Old)	22nd to 26th Dynasties.
	Saïte (New)	27th to 30th Dynasties.

Then, after a short gap, came the period of Grecian rule, under the Ptolemies, commencing 332 B.C., the first Ptolemy having been a general under Alexander the Great; and this is followed by Roman occupation in the year 30 B.C., Egypt subsequently for a long time forming part of the Byzantine Empire, as it has remained feudatory to Constantinople even to the present day. The building epochs also arrange themselves into four great groups, marked, as might be expected, by great divergencies of style, which may be arranged as follows:—(1) Pyramidal or Memphite, during the 4th Dynasty; (2) Proto-Doric or Early Theban, during the 12th Dynasty; (3) Theban or Late Theban, during the 18th and 19th Dynasties; (4) Ptolemaic, during the times of the Ptolemies and the Romans. Between these periods the throne seems to have been occupied by kings who devoted themselves to other arts than that of architecture, or the country appears to have been in a state of disorder, as during the rule of the Hyksos, of which little is known, between the 12th and the 18th Dynasties. The earliest buildings existing are all of the nature of tombs. It seems that the Egyptians, with some vague idea of the Resurrection such as has been possessed by many heathen races, had a belief that the body would come to life a second time some 3,000 years

determine, as the original granite casing has all been removed, and only the limestone core remains. The granite casing is said to have been so perfectly worked that not even a thin piece of paper could be passed into the joints; and this is still the case with the

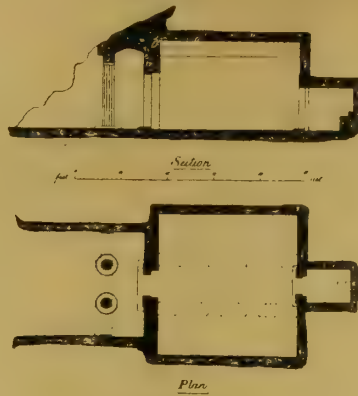

TOMB - BENI-HASSAN.

granite lining to the passages with which it is traversed, and which penetrate even into the rock upon which it is built. How the blocks could have been worked so perfectly, and how raised into position when worked, still remain unsolved problems to the present day. The fact of the tomb chamber having been found unoccupied when explored has caused the promulgation of many theories as to the reason for the existence of the pyramid at all, one of an exceedingly fanciful nature being that it was a prophetic building erected by Melchisedech, and another, put forward by a well-known astronomer, being that its passages, and the groves along their sides, were intended to perform the office of huge telescopes for the observation of certain stars at certain times. If the remains of the pyramidal epoch be few, even though colossal in size, those of the succeeding period, the Proto-Doric, are fewer still and small withal, but they make up for this by foreshadowment of greater things to come elsewhere in later ages. Some half-dozen dwellings were excavated during the 12th Dynasty, and about the year 2300 B.C., in the limestone escarpment bordering the Nile Valley at Beni Hassan, these being subsequently used as tombs upon the death of their inhabitants. Reference to the plans will show that the arrangement was that of a single chamber with the roof supported by columns, not built up, but simply left out of the solid rock when the chamber was excavated. In the principal case there is also a smaller chamber within, evidently used as the tomb; and in that, as in most instances, a verandah was formed in front of the entrance by carrying the overhanging rock there also by columns. The arrangement is precisely that which might be expected in a small flat-roofed timber house in a hot country, from which the inspiration is most evidently taken; as is seen at once by examination of the front of the verandah, for the columns have small abaci, representing bearing-pieces of wood, between their tops and the lintel which they carry. This lintel is in the form of a horizontal architrave or beam of wood, and above it are representations of the ends of longitudinal rafters such as would carry the flat roof; while large flat circular discs are employed as bases, again, like the abaci, to act as bearing pieces, this time to distribute the weight of the columns over the surrounding surface. In reality, however, the parts are not pieced together as the above description might lead one to suppose, but the whole is left of solid rock, without joint. A great deal has been made both of this plan and of this elevational arrangement, as being the prototype of not only its immediate successors, the Egyptian Temples of later Dynasties, but of the Grecian Doric order. The plan of a pro-stylar temple consisting of a simple cell, with side walls extended in front and columns placed there so as to form a verandah or entrance, is here seen clearly enough; but whether the temple plan was derived direct from these tombs or from the type of building from which these tombs were also derived, and which must have been in common use for several hundreds of years, is questionable. So, too, it is with the general

features of the elevation—and perhaps it is more interesting to believe that these tombs merely represent in stone a type of building, common for a long period of time, proving it to have been of exceedingly ancient origin, than to imagine that the inspiration of the Grecian temples was taken direct from them without any connection across the many centuries between their dates. The most curious feature, however, is the occurrence of flutes, or hollow sinkings, in the verandah-supporting columns of the principal tomb. There are sixteen sides to each column, and each side is slightly hollowed as if to emphasise the arris, or edge—and similar flutings appear, at a much later date, in the columns of the Greek Doric order, there being no known examples at intermediate periods to carry on the sequence. As to the origin of these there have been many theories, but probably the columns were first left square (as they still are to some of the tombs), then octagonal by the removal of the edges, then sixteen-sided; and then, looking awkward, the sides were sunk for emphasis as said above. In another of the Beni-Hassan tombs there are two transverse rows of three columns each, the columns forming quatrefoils on plan, being composed of four reeds of large size, or possibly representations of four circular wooden posts of small section, bound round near the top by representations of grass binding, the interstices being filled with short fillets. Above this binding the reeds swell out, forming a bud-shaped capital, and above the capital is a shallow abacus. The columns taper considerably, and the form is one which came into very general use later on. As usual, the theorists have been busy as to its origin; but it is, perhaps, best to record only that which is obvious. Between the 12th and the 18th Dynasties there is an unbridged gap

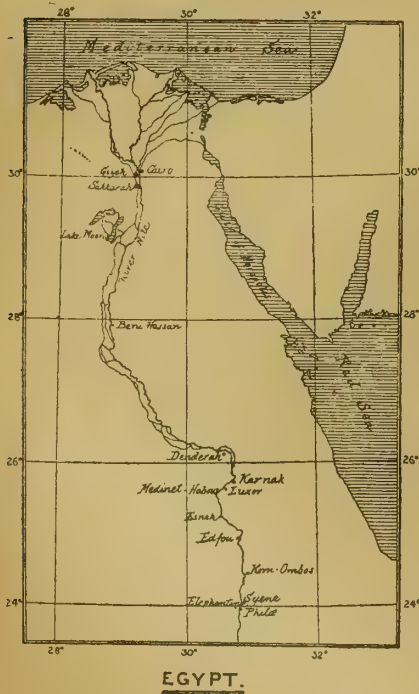

EGYPT.

after death, if properly preserved. Hence the mummies and the solid tombs. These latter first took the form of square-based pyramids—evident successors to simple tumuli or heaps of stones; and the earliest of these of which remains exist is the Great Step Pyramid at Sakkarah. Accepting the earlier dates in all cases with caution, its erection is generally ascribed to Ata, King of Egypt, about 4300 B.C. Besides this, all that is known of it is that it consists of six huge steps of limestone masonry, arranged one upon another until a rough pyramidal form is attained, the steps being respectively 38ft., 36ft., 34ft., 32ft., 31ft., and 29ft. high. If there were any intermediate stages between this and the perfect pyramid, they have been lost; but of these latter there are many examples, the principal group being at Gizeh, near Cairo, and the principal one of the group being the famous Great Pyramid of Cheops (or Khufis), which is supposed to have been erected about B.C. 3733. Each side of its base measured about 760ft., and its vertical height 450ft.; but its actual dimensions are difficult to



Colonnade. LUXOR.

in the history of Egypt, all that is known being that it was overrun by the Hyksos or Shepherd kings. It was evidently a time of disorder, and no buildings of the period remain. With the 18th Dynasty, however, there opened the greatest building epoch which Egypt ever saw, the Theban Period, as, also, this time was that of Egypt's greatest prosperity. Then it was that the Israelites were captives in Egypt, Ramesses II., the third king of the 19th Dynasty, being generally believed to have been the Pharaoh who withstood Moses. The great buildings of this period are all close together at Thebes, further up the Nile than Beni-Hassan, and now take the form of huge temples arranged upon a well-thought plan, one story only in height, but majestic and awe-inspiring in appearance. Externally they were simple, forbidding structures, with plain walls inclined inwards, and crowned with the invariable simple cavetto cornice, and with entrance at one end only, between huge masses of masonry called "pylons," in the form of truncated pyramids, again with the cavetto cornice crowning them. Internally, the arrangement was always symmetrical round an axial

passage-way, so managed that when standing at the main entrance a view was obtained through the entire length of the temple to the shrine of the deity at the extreme end. This would be as impressive a view as could well be imagined, through sunlit courtyards and dark pillared halls alternately, with brilliant, nay gaudy, colouring used lavishly upon the walls and columns. The great temple (or palace—probably both) at Luxor, a fairly typical example, was erected in three stages. The earlier portion dates to, at least, 1500 B.C.—the time of Amenophis III., a king of the 18th Dynasty. It consists of the shrine, with a great number of small chambers round it, then, in advance, a deep pillared hall, opening along its entire width into a great courtyard, with double colonnade on either side, the whole being closed by a pair of massive pylons with the entrance gate between. Later on another hall, comparatively narrow, with two rows of columns down its length, appears to have been added, another pair of pylons with entrance between being erected. So far the usual axial arrangement was preserved, but in making the subsequent addition of another open courtyard, with a double colonnade all round, and with yet fresh pylons at the new entrance, the axis has been lost, and the plan of the courtyard is not rectangular. Of a slightly later date is the temple at Karnac, it being generally ascribed to the time of Seti I. and his son Rameses II., circa B.C. 1400 to 1333. Its general arrangement is very similar to that of the temple of Luxor, save that a small temple has been inset into the side wall of the outer courtyard by Rameses III., as late as 1200 B.C.; and an outer pair of pylons was added again much later, in the Ptolemaic period. From the outer courtyard is

characteristics of arrangement, as does also the temple of Medinet Habou, erected by Rameses III., the first king of the 20th Dynasty, about 1200 B.C. So exceedingly conservative were the Egyptians in their religious rites, as

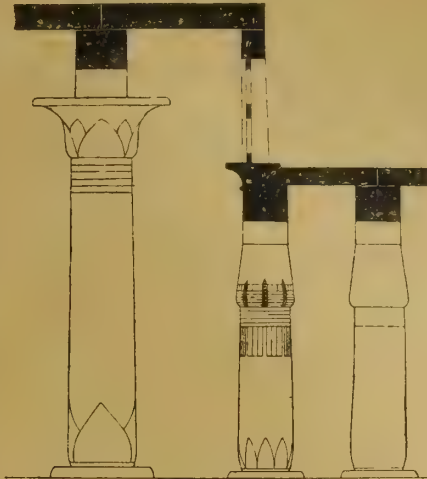

Part Section through Hypostyle Hall, Karnac.

well as in their general mode of living, the son always adopting the father's trade and working according to his rules and methods, that even in the three hundred years of the Theban period of architecture little variety is to be found. Even in the later examples, as at Medinet Habou—and of course it will be understood that there are many smaller monuments which are not mentioned here—there is but slight change noticeable. There is the same extreme vigour and imposing strength, but sculptured figures are now more often found in front of, and even attached to, the square supporting columns of some of the colonnades and halls. The sculptor's art had reached a high state of perfection at a very early date, but its productions do not appear to have been directly connected with the buildings till somewhat later, and then gradually more and more. Still, it was at all times most architectural in character, harmonising in its massive solemnity in a most wonderful manner with the tombs and temples. Following strict laws of proportion and posing, it may be called conventional portraiture of the highest order; and so little variety of method is to be noticed that it is exceedingly difficult to understand the great distance of time between the erection of the great Sphinx, which, close to the Pyramid of Cheops, is by many authorities contemporaneously dated, and the well-known portraits of Rameses II. Obelisks, too, were during the Theban period frequently used as architectural features, being erected in pairs, as at Karnac, outside the entrance-doors and pylons.

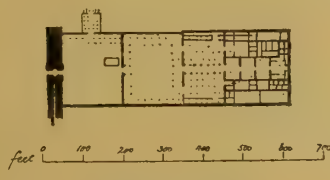

THE RAMESSEUM.

Besides the erected temples, some few were excavated in the rock during the 18th and 19th Dynasties, the most important being that at Abu Simbel (Ipsamboul), of the time of Rameses II., and that at Mount Barkal, the date of which is more difficult to determine. The simplicity of arrangement noticeable at Beni-Hassan is no longer preserved, that of the axial passage-way being followed, with every other detail of the open-air temples, so far as was possible under the changed conditions; save that at Abu Simbel side chambers are to be found, as if they were subsequent excavations. It was only the inner portion of the temple of Mount Barkal, however, which was excavated, the two outer courts or halls having been built against the face of the walls. At Abu Simbel it was different. All there was rock-cut, and the entrance was made as nearly as possible to represent a magnificent

pylon, with four colossal seated figures attached to and excavated out of the face of the rock. Inside, in the entrance hall (representing the colonnaded open court of the erected temples) are two rows of huge standing figures, certainly much smaller than the external statues, but still 60ft. high each, which appear to carry the roof, but which are, in fact, quite clear of it, looking straight in front of them, as all Egyptian statues do, apparently ignoring poor, feeble, pygmy man, with his short existence of three score years and ten. Wonderful and noble edifices are these temples of the Theban dynasties of Egypt; and a small point of additional marvel has recently been brought to light and announced by Professor Goodyear in the *Architectural Record*, of New York, in the fact that the courtyards of Luxor, Karnac, and Medinet Habou—and also that at Edfou to be mentioned presently—are not quite square, the cornice lines at least being always somewhat curved convex to a spectator standing within the court, the curve being sufficiently subtle to be unnoticeable from below, but yet inducing an appearance of greater dimensions to the court than those which actually exist. After the death of Rameses III.—with whom, it will be remembered, the 20th Dynasty opened—the prosperity of Egypt rapidly declined, and at the close of the Dynasty in 1100 B.C., the state of the country was not much better than it had been when the shepherd kings (Hyksos) were in possession. The natural result followed, and all building of importance ceased, the art of architecture only reviving with the later prosperity under the Ptolemies, even though there was



Colossi at Entrance to the Temple at Abu Simbel.

comparative peace during the 26th Dynasty, from B.C. 666 to B.C. 528. It was with the conquest of Egypt by Alexander the Great, in B.C. 332, and with the accession of his general Ptolemy, that building really recommenced, and, strange to say, upon almost precisely the same lines as a thousand years before. Throughout the length of Egypt the old temples were restored and new ones built in a style which imitated and almost equalled that of the Theban period. Everything upon the island of Philæ belongs to this time, the worship of Isis commencing there in 286 B.C. and the worship of Osiris being continued till 453 A.D., and the greatest of the other erections were the temples at Denderah, 200 B.C., Ediou 237 B.C. to 57 B.C., and Kom-Ombe. Even a casual glance at the plan of Denderah shows how similar it is to the temples of the 19th Dynasty. There is the inner sanctuary, then the pillared hall, and then the open court, with its pylon entrance, all arranged about an axial passage. The differences are those of proportion and detail rather than of general effect. There is a certain loss of massiveness and dignity, compensated by greater elegance, especially in the small single-cell temples, such as that commonly known as Pharaoh's Bed upon the island of Philæ—a delicate little gem. Like much of the work of this period, it depends largely for its effect upon its carving, for the ornamentation which a thousand years previously had been painted upon the buildings was now carved, and it was in the capitals of the columns that the change was most marked. The bud form has by this time gone out of use, but the bell is enriched with foliage lavishly applied. As a rule, fern and other leaves are represented rising above the binding straws, still present as binding together the reeds of which the column was supposed to be built up. Often

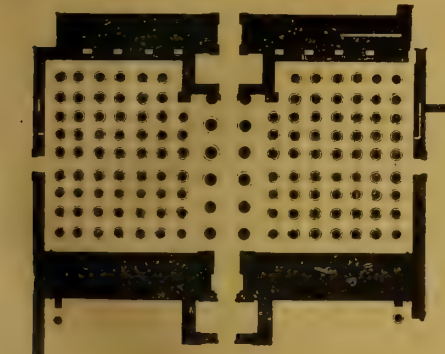

Hypostyle Hall, Karnac. Theban Period.

entered a great pillared hall, famous as the Hypostyle Hall of Karnac. The axial passage of the whole building lies between two rows of columns, 60ft. high, resting on circular discs as bases, then swelling suddenly and afterwards tapering to a capital which is of bell form. The abacus above, instead of being a thin broad bearing slab as at Beni-Hassan, is cubical and comparatively small. This central passage is roofed with flat stones in the usual way at a high level, but on either side are several rows of lower columns, carrying a roof at a lower level, light being admitted to the central portion by a series of clerestory gratings or openings. The shorter columns very much resemble the reeded columns at Beni-Hassan, having a bud-shaped capital of exceedingly similar character; but they have a swelling or entasis, as have the tall columns, and are circular, and not reeded in section. This, however, is not a necessary peculiarity of the period, for reeded examples are to be seen at Luxor, though the entasis is always present, and the abaci are small cubes which do not appear to bring the weight at all well upon the capitals. The ornamentation, it may be remarked, was generally painted and not carved during the Theban period, with the exception of the symbolical winged-globe, which appears in bold relief in the cavetto cornice over every doorway—and excepting, too, the hieroglyphic inscriptions and representations of scenes from everyday life which are commonly found incised upon the wall surfaces. It seems that the ornamentations of the columns generally took the form of representations of reeds, and leaves, and binding straw bands, as if the column had originated in bundles of reeds or posts, and not in large tree-trunks or in monolithic quarry supports. Contemporaneous with the temple at Karnac, and undoubtedly of the time of Rameses II., is the Ramesseum. It again exhibits the same

they assume most graceful forms, and the Corinthian capital of the Greeks is frequently found closely followed in general scheme. A strange point to be noticed is the retention of the axial arrangement even in these ornamental capitals, those nearest to the axis on either side being alike, and no others, or, in flanking colonnades, the first on the right of the axis being similar to the first on the left, the second to the second, and so on. Another form of capital which was now in common use was square, with the mask of a female head carved upon each face, while the abaci above the capitals were also carved in representation of small pylons. The columns, too, no longer rest upon circular discs as bases, but upon a continuous step or stylobate, and, more than this, they are joined to one another, save at main axial openings, by a dwarf wall reaching up to about one-third of their height. This wall has a small cavetto cornice, like those to the main colonnades, the doorways, and the pylons, frequently ornamented with simple, vertically-rising leaves. These comparatively slight differences are all that distinguish Ptolemaic from Theban work, yet they are sufficient to enable a judgment to be pronounced at once as to which period any particular building belongs. Thus it will be seen that there are four great Egyptian building periods, with gaps of time between, the styles of the first and second being distinct, and of the third and fourth almost identical, in spite of an interval of nearly a thousand years between them.

#### EXPANDED METAL IN ITS RELATION TO FIREPROOF CONSTRUCTION.\*

WHEN accepting the invitation to address this Society, I was not only conscious of the honour it conferred upon me, but also of the great responsibility its acceptance imposed, especially as the subject proposed is one capable of elaborate technical treatment. But as your members do not require a technological treatise on the physical elements of building materials, this paper will so far as possible be kept within the limitation of an explanation of the character and the means of using expanded metal for floors, partitions, ceilings, &c., in combination with other well-known materials employed in the construction of buildings. The structural novelty of expanded metal has never failed to attract and interest all those who have seen it. It is metal distributed in that latticed form which never goes out of fashion, and it can be applied to almost every purpose for open metal-work as at present used. It is about nine years since expanded metal was first produced in commercial quantities, and then with considerable difficulty, as a machine had only recently been invented which would operate on the metal so as to simultaneously cut and open it. The perfecting of the details of this machine had still to be invented, and the knowledge of suitable metals for cutting and expanding had to be acquired. It was then an entirely new article, manufactured by a method necessarily peculiar to itself, and with an untried field for its employment. It is not surprising, therefore, that considerable money and energy were misdirected in the endeavour to vitalise it. There was, however, a serious limitation to the use of the products from this machine, owing to the fact that they could not be expanded from plates above  $\frac{1}{8}$  in. in thickness, so that on account of this, and the imperfections of manufacture, the use of the metal was restricted almost wholly to lathing for plastering. The necessity for heavier metals, and for greater accuracy in cutting, was, therefore, ever apparent, and the result was the addition of another member to the family of expanded metal inventions in the form of a machine which operates alike upon the thinnest or thickest metals required, and with great precision, as will be observed from the various specimens of metal upon exhibition here. Before detailing some of the uses to which expanded metal can be applied, it will be perhaps best to draw some comparisons between the methods and manufactures of the old expanded metal and the new, which will assist in making clear the reason why the old metal was not more generally applied for exposed uses. The old metal was limited to thin sheets because the construction of the machine necessitated peculiar cutters which would not stand the strain required for heavy metals. The new machine is the embodiment of simplicity

and strength in all its parts, and is only a large shearing machine having one lower stationary blade of required length (say 8ft.) and a top blade, or series of blades, with corrugation representing half the sizes and forms of the meshes longitudinally, also means for feeding the metal forward to the cutters, and shifting it sideways between every stroke. The old machines each produced but one size of mesh or width of strand, and were limited in practice to sheets of, say, 4ft. in width. The new machines are individually capable of producing any size mesh by simply changing the upper corrugated cutters, and the width of the strands may be increased or diminished while the machine is in action. The old machine slit and opened the metal, giving much the same effect as if it was first slit and afterwards drawn open, which naturally caused the metal to shorten in length as it was opened, or expanded in width, this shortening being about 10 per cent. The new machine produces the expansion by stretching the strands as they are cut away from the plate, and consequently the finished article is of the same length as the original strip of metal, while it is increased from twice to twelve or even more times in width—that is to say, a sheet of steel 8ft. long by 6in. wide can become a sheet of expanded metal 8ft. long by 6ft. wide or more. In the old machine, motion was given to both the upper and lower cutters, both sets consisting of single cutters stacked alongside each other to the full length of the machine, and in this double movement the cutters had an almost uncontrollable action upon the metal, with the effect of distorting the produce, both in respect to the shape of the strands and of the finished sheet. The effect of the new machines is perfect alignment of cutting as to strands, and perfect squareness and regularity of the finished sheet throughout. There are therefore, besides, the almost limitless capabilities of the new machines as to varieties of products, great economy over the old, both as to the cost of construction and operating charges, and as to the quantity of metal plate required to extend over a given area. The patented processes and machines leading up to the present perfected system of manufacture are unique innovations from the routine of mechanical discoveries, and have been surprises even to engineers engaged in vocations most nearly associated in kind; so that I would ask you to pardon me if I feel some pride in the fact that there is sufficient similarity between all features of these various developments to establish them as my own offspring. Until quite recent years the classes of buildings wherein expanded metal is now largely employed were provided with floors of wood joists, and wood stud partitions, and wood lathing. This was dictated by the very obvious reason that the laths are but faggots with only an under surface of plaster to protect them from fire, and are left free above to communicate flames one to another, thus forming a fire trail to both sides of the wood joists supporting the floors and ceilings. The marked change towards the further elimination of woodwork from buildings and the substitution of all iron columns, girders, joists, &c., is shown by the fact that more than 75 per cent. of the expanded metal lathing used prior to, say, five years ago was for application to wooden joists, studs, &c., the balance of per cent. being in combination with other ironwork about the buildings, whereas at the present date these figures are reversed in nearly equal proportions. The expanded metal lathing now not only serves to incase the main girders and columns, but also to form suspended ceilings under what were once termed fireproof floors, consisting of rolled girders with concrete fillings between them, also for forming double or solid partition walls. The importance of protecting exposed ironwork from the direct contact of flames has become so apparent that new structures without these provisions are rarely to be met with. In fact, there is a general disposition to cover these in the older buildings, and the stimulant to this is noticeable immediately following the recurrence of great fires, such as the Cripplegate conflagration. The advantages possessed by expanded metal lathing, rendering it so largely useful as a building material in combination with plasters, are, that it is fire-resisting, manufactured in form convenient and economical for application, being in flat sheets, and requiring no stretching, has the maximum uniform key, and is buried within the plaster. The first proposition—i.e., fire-resisting—needs no sustaining; but the question is asked, Will it not expand under considerable heat to

disturb the plaster? This has been answered in the negative by many tests, and the reason is that the sheet-steel from which it is made no longer presents the same rigid plane for expansion or buckling, but that it has been slit into numerous strands of small section, and these reticulated in such a manner as to permit each of such strands to expand, thus reducing its effect to an infinitesimal quantity, and this is compensated for by the yielding nature of the plaster. The first form of sheet-metal lathing with which I became familiar consisted of corrugated and perforated sheet-iron; sheets of such lathing, when used externally on buildings exposed to intense sun heat, continue to expand and contract, and it has been found impossible to keep them covered with cement mortar. Instances like these prove that for metal purposes the less there is of the original sheet left in its flat and corrugated form the better. The second proposition asserts its convenience in form for application, and this will be understood when it is known that it can be produced in flat sheets up to 8ft. in length, and in width of from a few inches to several feet—in fact, wide enough to incase the largest girder or column if desired. In one direction the material is sufficiently rigid to span a considerable space without other support, and yet sufficiently yielding to form self-supporting corners, &c.; while in the other direction it is readily bent, and retains itself at any desired angle. The third proposition asserts superior keying qualities for plaster. The strands forming the meshes lie at an angle of nearly 45° to the plane of the sheet of lathing, so that if the plaster only filled the sheet equal to its thickness it could not be removed except at the angle of the strands without it was first broken up. The key, however, in practice will be seen to pass through the meshes and overlap the strands, effectually burying the lathing in the mortar, and thus preserving it from exposure and oxidation.

#### PARTITION WALLS.

The second development of expanded metal in structural work was the formation of solid partition walls, and the present system of erecting them was due to two suggestions. One to an inquiry as to the use of the metal without supports while imposing the plaster; and the other a criticism on the use of angle-iron studs to carry the lathing. The first inquiry was in the interest of economy, while the criticism was that the angle-irons, being of stiff section, must under-heat, expand and distort or destroy the partition. As a result, we have a near approach to meeting to both these suggestions—viz., the taut wire studs into which the lathing is interlaced and covered with plaster to a thickness of 1½ in. or 2 in. These are economical both as to first cost and in saving of floor space, and are as fireproof as the nature of the cement plaster permits. The item of saving of space is of very considerable importance in large cities, especially in sub-dividing offices, in forming stair and lift shaft casings. This invention germinated in England, and was taken up with great avidity in the United States, and is employed in many of the largest modern buildings, the area of such partitions erected annually probably extending a million super yards. They may be built within any existing building, and at any point without other foundation than the flooring as they are comparatively light, and when set hard become a monolithic slab equally distributing their weight. The advantages of this feature over segmentary constructions will be readily understood. They are surprisingly sound-proof, as has been witnessed by many tests at London.

#### FLOORS.

The third development of the use of the expanded metal in fireproof building construction relates to its use as a tensile bond in concrete floors. This was also a very natural adaptation of the metal, because of its manifest and surprising supporting strength. The stiffness is due to the fact that the strands are set edgewise to the plane of the sheet of expanded metal, their combined width representing the width of the original sheet from which it is made. Thus a sheet of expanded metal of 3in. mesh and ½ in. wide strands represents a strip of steel 6in. wide set upon edge. The carrying capacity of the 3ft. width of expanded metal, it is true, is not so great as the 6in. width uncut would be standing edgewise, for the reason that in the expanded form the strands do not set vertically, but as in the lathing, approaching 45° from the plane of the sheet.

\* Read before the Civil and Mechanical Engineers' Society, Feb. 17, by Mr. J. F. GOLDING.



But as these are supported in their lattice-like position one by the other, their carrying power is many times that of the original sheet when laid flatwise and tried as a beam. This metal, of varying meshes and weights, is used for the manufacturing of flooring, paving, slabs, lintols, &c., but most commonly for the making of concrete floors *in situ*. This is done by laying the expanded metal loosely upon the ordinary centring, so that it will reach from girder to girder or wall to wall as the case may be, and imposing the concrete upon it. It is not possible in practice to either have the centring on the expanded metal so exactly flat, but that with the weight of the workmen treading upon the sheet in the act of imposing the concrete will cause it first to slightly rise up at some point, thus permitting the concrete to pass under the metal, and which prevents it again from returning to the centring, and as they tread again at the other points, the metal will be found to have taken its place wholly within the concrete, so that when the centring is removed, the metal is not visible, but is in the best position as a tensile member and bond to the concrete. No. 8 expanded metal, which is 3in. mesh,  $\frac{1}{2}$  by  $\frac{3}{8}$  strands, made up into a slab of concrete 6ft. 3in. long by 2in. wide by 3in. thick, has been proved to increase the strength of the slab more than tenfold, as is stated in Messrs. Fowler and Baker's report. All the tests made by this eminent firm of engineers gave this as about the average result. The utility of this metal in concrete as against rods placed at right angles, as is done in the Monier system, is evident when we take into consideration the fact that the expanded metal is a continuous solid connected web work within the concrete, and that weight imposed at any one part distributes the strain over a larger area than it is possible for sheeted rods to convey. And besides, a large sheet of expanded metal, say a square of 8ft., is laid in a few seconds, whereas considerable care is required in placing rods of a given distance apart in either direction, and especially so if they require to be tied at the intersections. There are several systems of concrete flooring to which expanded metal has been adapted—viz. :—

(1) A continuous slab lying above girder or wall supports. (2) The metal placed between rolled iron joists and resting upon their lower flanges. This latter practice may be done *in situ*, or by casting the slab and placing them between the joints as they are laid. If cast *in situ*, a strip of the lathing mesh somewhat wider than the joists may be laid beneath and longitudinally with them, so that the concrete passes through the larger mesh with it, thus providing a surface to receive plaster beneath the joists when the centring is removed. It has been extensively used in concrete arches—in some cases, the metal lying immediately upon the arched form of centring; and in other cases, as at Kennet Wharf, London, E.C., the arched centring was filled with concrete to slightly above the crown of the arch, when the expanded metal was laid flat from girder to girder, and the filling in of concrete continued. By another system considerable length of span between supports is obtained. As before stated, there is no single system of floor which seems to lend itself to all requirements, and this particular floor, generally described as the channel arch system, has proven to be most economical where spanning of considerable distance is necessary. Its special advantages are that it produces an exceedingly rigid floor with a minimum amount of material, and its consequent lightness. This flooring may finish up either with or without a suspended flat ceiling, or with a dome ceiling, as shown in Plate 9. There is no limitation upon the span of flooring or roofing to be obtained by this system within the average requirements for buildings. One of the first works carried out on this plan was a reservoir roof, having a clear span of 60ft. In this instance the arches were about 8ft. deep at walls and the apex of the roof some 6ft. above the walls, giving a rise of about 14ft. The channel supports were 7ft. apart, and the thickness of the concrete between channel supports, including the finish, about 3in. These floors, of 12ft. spans, the channels at 4ft. centres, with 12in. rise, with 3in. thickness of the flat concrete, had been loaded with 17cwt. per super. foot, and variously otherwise tested until their strength and utility has been fully established. I have to thank you for your very kind attention to this subject, and trust, if I have not succeeded in conveying anything specially new, still, that I may hope to have awakened such interest in the

matter as will enable those of you of inventive turn of mind to improve upon the methods of using expanded metal to your great advantage, as well as to my own.

#### LAST SUMMER IN BRITTANY.

HOWEVER enjoyable the thorough change of a long sea-voyage may be to the typical business man, the average one cannot find complete happiness in utter laziness, and so it seems to me this is a capital time to jog down collectively a few odds and ends. They are notes written on the spot—last July and August—during a happy holiday in Brittany and Finistère, when the same ground was travelled that I had previously gone over fully a quarter of a century before. The entries that follow are given just as they come in my pocket-book, and may be taken for exactly what they are worth.

ST. MALO.

Seen from any point of view, this most picturesque old place looks as quaint as ever. Surrounded entirely by its Mediæval walls (so broad in places that two carriages can be driven abreast upon them), these ramparts represent a preambulation of exactly half an hour if the visitor cares to walk around the top of them. Scarcely a new house has been erected within these sturdy walls for something like 300 years; so, needless to say, no builders live there, and there are—no strikes! Practically, the whole place is built of grey granite, the streets are very narrow, and the houses are exceedingly high. A great improvement has taken place in all sanitary arrangements since my last visit. Then it was quite customary to throw "slops" of all kinds out of the windows, making the thoroughfares, in that respect, more dangerous than some of us can remember old Canongate, in Edinburgh, to have been. Happily, all this has been changed for the better; water has been laid on to every house, and the ordinary requirements of civilisation are now the rule, and not the exception. The internal old woodwork of many of the houses is most interesting. For instance, I slept for a week or so in a panelled chamber, to which access was only gained by mounting steep winding stairs, with solid wood risers, built like those in a bell turret. There are massive beams in the room supporting the ceiling, in the centre of each of which were bold bosses, carved in the solid. St. Malo, although quite a small place, contrives to support no less than four master woodcarvers, who appear to at once do excellent work, and to obtain a comfortable living.

Founded upon a rock, the place is practically an island, so, like New York city, it cannot grow any bigger in its actual state; but during late years its environs have increased wonderfully. Dinard, on the opposite side of the water, now claims to be a thoroughly ideal modern French watering-place; but St. Servan, which one supposes is a kind of mainland to St. Malo, keeps as dull as ever. One of the connections between these two places is a most remarkable moving bridge, known as "Le pont Routant." The tide at St. Malo, as is generally known, falls and rises very rapidly, something like 40ft. The bridge (if it may so be called) takes the form of a tramcar, supported up to the level of the road from the bed of the river by a tall, slim framework of iron, which, worked from the bottom, steadily traverses the distance from shore to shore, no matter how high or low the tide may be. When the latter is down this lift-like working-car moves along quite two score feet in the air, and has a most peculiar appearance.

The most charming feature about St. Malo is undoubtedly the splendid bay, with its broad sands extending around the coast to Parame, itself a pretty bathing-place, about two miles away. A new spire has just been added to the church at Parame, and at the time of our visit, although completed, was still surrounded by a network of scaffolding. A steam-tram, running at frequent intervals, unites the two places, whilst a light railway connection goes on from Parame to Rothéneuf, another little coast village smuggled in another bay a few miles further east. Here a number of pleasantly-situated villas have quite recently been erected upon various advantageous points overlooking the sea. It was regrettable, however, to notice that here, as at so many other places in North-western France, the tall, venerable, old village cross, consisting of an octagonal oak shaft upon a granite base, has its upper part, above the crucified Christ, falling

to pieces. This interesting 17th-century cross is apparently quite uncared for and neglected. At Rothéneuf a grand hotel has lately been built opposite the sea; at present it looks very much too large for visitors, even at the very height of the season. The desolation in winter must be such as may be felt.

On the shore, all around the bay between St. Malo and Parame, detached villas, many of them handsome mansions, have sprang up within the last few years, and form a continuous connection between the two places. There is also a very large and pretentious new casino. Substantially erected, these villas are distinctly un-English in appearance. The same kind of dwelling-house one will find to-day being erected by the score outside Amsterdam and in the suburbs of Chicago. So, nowadays, to those who know both sides of the Atlantic, it is difficult to feel sure whether the styles for detached and other residences most affected should more correctly be defined Continental or American; certainly, for artistic, well-composed, and conceived mansions the new school of American architects are in noway behind their average European confrères.

DINAN.

The Rance is a pretty river, as much like, in size and sylvan beauty, the Dart or Tamar in Devon as well could be. The steamer ride from St. Malo to Formosa (the waterside village at the foot of the hill Dinan is built upon) is lovely. Dinan itself is perched on the summit of a steep, scarped rock, high above the Rance, and the deep gorge through which the latter flows is spanned by a high Roman aqueduct-looking bridge of ten or a dozen arches. The torturous, steep, old street, known as the Rue du Jerzual, that connects Dinan with Formosa, is one continuation of ancient half-timbered houses, all and everyone of exceptional architectural interest, but all in an awfully tumble-down state. The ancient fortifications are almost intact; some parts of them date from early in the 14th century. Near the cathedral it is deplorable to see quite a row of old curiosity and second-hand shops, filled to overflow with Mediæval Calvaries, old Breton bedsteads, carved statues, and other interesting examples of ancient woodwork, evidently ruthlessly torn (and recently) away from their original positions. The same lamentable exhibitions of deliberate vandalism may be seen, perhaps in a rather lesser degree, at Morlaix, Brest, and other places in the north-west of France.

BREST.

Brest is about so far west of Paris (387 miles) as Edinburgh is north of London; but the train services of the two countries will bear no comparison. In London the would-be traveller may take his pick of half a dozen third-class trains daily, doing the distance in from 6 $\frac{1}{4}$  to 8 $\frac{1}{2}$  hours; but, between Brest and Paris, there is only one through train daily (first and second class only), and it takes 14 hours or thereabouts in the journey. Brest is about the size of Plymouth, but the latter cannot compare with it in position. Brest harbour has the goodly reputation of being one of the three finest in the world. It is almost lardlocked, its only connection with the Atlantic being by a narrow entrance called Le Goulet. Brest itself stands upon elevated land overlooking this fine inland sea, the latter bordered around by pretty and varied coast scenery. Its two admitted rivals are the bays of Sydney and Rio de Janeiro respectively. The far-famed lovely stretch of waters just inside Sydney Heads our Colonial cousins are most justly proud of, but it admittedly lacks the sublime grandeur of the towering mountains which enrich the bay at Rio. The bold, precipitous headlands which guard the entrance to Sydney, are, we know, strikingly majestic; they pale, however, before the stately sugar-loaf, which stands like a giant sentinel over the portals of the "Bay of Hidden Waters" (as the Indians were wont to call it). Brest itself is distinctly a "bay of hidden waters," and there are more things hidden there than one, for it and its harbour are undermined, it is said, for defensive purposes in every direction.

The main thoroughfare in Brest is Rue de Siam, a long, straight, somewhat narrow street, with even narrower sidewalks. Just on entering Brest by rail on the southern side of the line is a cleverly-designed house; it is of considerable size, and its graceful turrets rear up very happily above the tall trees amongst which it is built. This is the Château Ker Stear, erected about 12 years ago from the designs of M. Chabal, archi-

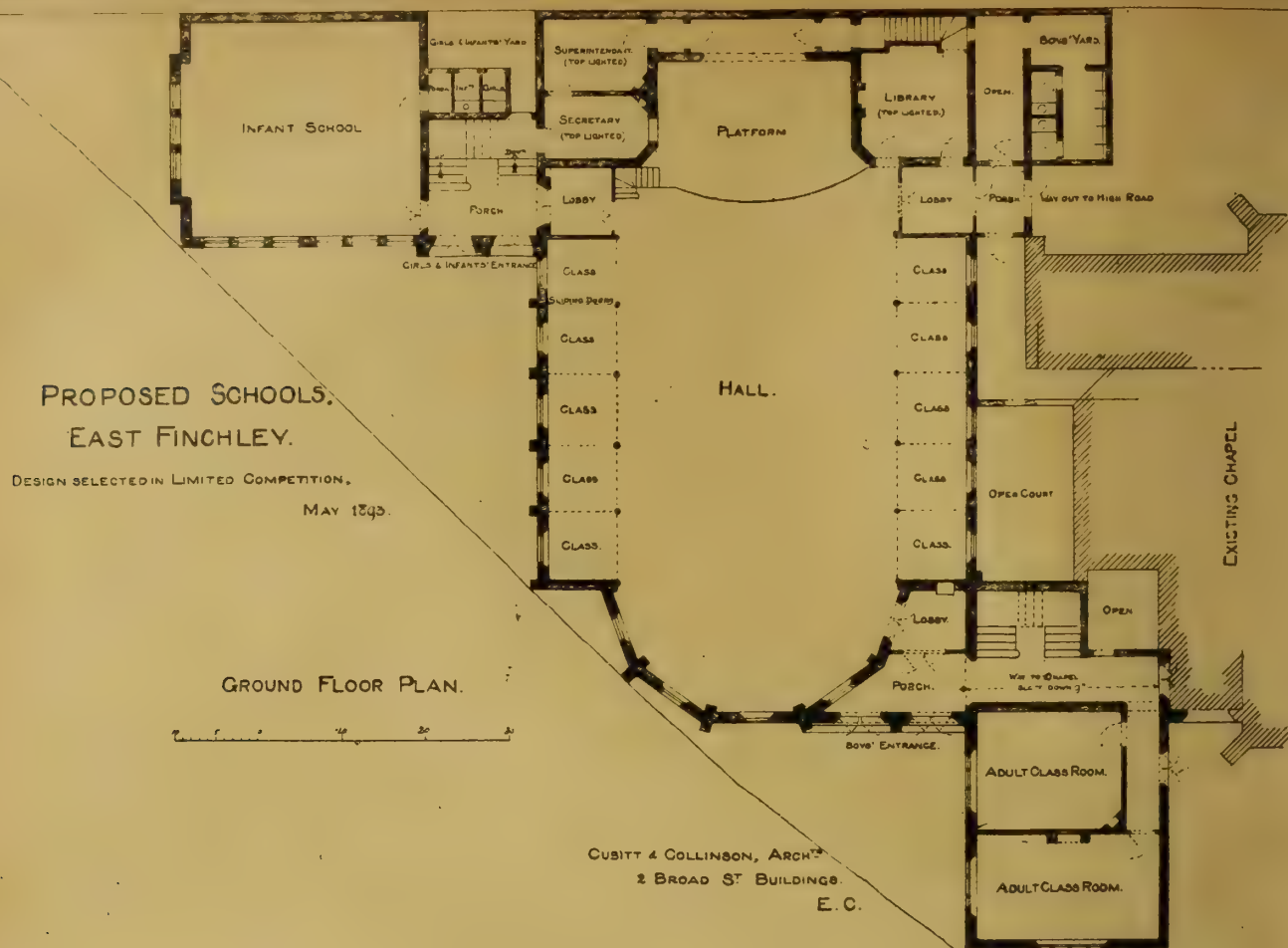

tect, of Brest. If this is this gentleman's usual style of work, then the mantle of the late Viollet le Duc rests worthily upon his shoulders. Little actual building is apparently going on in Brest. At the bottom of the Rue de Siam a large site has been made by the clearance of tumble-down, inferior buildings. It all consists of municipal property, but nothing has yet been decided as to its ultimate use. Some old buildings have also been demolished in another part of the city, and this will admit of the continuation of the Rue Admiral Linois into the Rue de St. Yves. Once finished, it will open up a new street, parallel to the Rue de Siam from the Boulevard Thiers, and must give much needed relief to the traffic at the southern end of Rue de Siam, a thoroughfare whose unfortunate contracted width has already been touched upon. A large new building, by no means ornamental, has lately been erected on the Place du Château, a fine open space in front of the interesting old 13th-century castle. It is intended as barracks, &c., for the staff of the engineer corps.

Brest, although nominally the terminus of the Western Railway of France, has two light lines running out from its station, both built three or four years ago. One of these is the departmental line which joins Brest with St. Renan and Ploudalmezeau, a distance of 32 kilomètres (20 miles), and the other to Lannilis, 30 kilomètres (19 miles). The latter section branches off at Rufa junction, which is a mile or two out of Brest. Further, at the time of our visit (last August), labourers had already commenced to cut up the main streets, and electric cars, on the trolley system, will soon be, if not already, running in Brest. When this comes about the old fortification, and the old inhabitants, will, indeed, be astonished at such an unusual spirit of innovation in their midst. The shady walks upon the ramparts are simply delightful. The Rue de Cours Dajot, 1,600 metres (about one mile) long, is a superb promenade, giving a fine view of the roostead. At one end is a marble statue of Neptune, and at the other (the western) of L'Abondance. They are both the work of that great sculptor, Coysevoet, and, after having been vilely mutilated during an insurrection at some time or other, were conservatively restored five or six years ago. They each bear

the following inscription:—"Donné à la Commune de Brest par le Gouvernement Consulaire le XIII. Germinal, an IX."

The cemetery at Brest is on high ground outside the town; it is well filled, many of the memorials being exceedingly good. This God's-acre is shady, and has sweet-smelling flowers growing everywhere. A painful interest centres in the monument over the bodies of the Brothers Whipp, who went down with the *Drummond Castle*. The memorial consists of a tall cross and body stone of polished black granite, with an inscription running—

In loving memory of Frederick Walker Whipp, aged 34 years, and Walter Walker Whipp, aged 30 years, youngest sons of James and Mary Whipp, of Clitheroe, England. They were drowned near Ushant by the foundering of the ss. *Drummond Castle* when returning home from South Africa, and their remains are interred here. "In death they were not divided."

The statuary who made this monument also erected those to the memory of other victims in the same catastrophe that we saw at Lockrist and St. Patri, near Lannilis, on the coast, and upon the islands of Molene and Ushant (written Ouessant, and pronounced Wis-song in French). He has extensive yards in the Rue de Paris and Rue du Cimetière, opposite to the entrance to the burial ground at Brest, and is a very jolly man of 60 odd summers. His card reads—

JULES POILLON,  
Sculpteur Marbrier,  
Conseiller Municipal.

I have been a town councillor myself, and know many others who have also filled the same kind of office, but never saw "Town Councillor" printed on a business or private card before!

Through the courtesy of Mr. W. R. Hoare, the energetic British Consul at Brest, I am able to give the following particulars as to the wages paid in the building trade in the city where he so ably represents the interests of our countrymen. Carpenters, 3f. 50c. (2s. 11d.), wages paid monthly; granite and stonemasons, 3f. 50c. to 4f. 50c. per day (2s. 11d. to 3s. 9d.), paid weekly or fortnightly; plasterers, the same pay as masons, but received fortnightly or monthly; painters, 3f. 50c. (2s. 11d.), paid every two weeks. Plumbers are also paid every fortnight, and receive 3f. 75c. to 4f. per day (3s. 1½d. to 3s. 4d.);

bricklayers, 3f. to 3f. 50c. a day, their wages paid fortnightly or monthly; labourers, 2f. to 2f. 50c. (1s. 10d. to 2s. 1d.), these receive their money every night. All the above trades work, in summer, 63 hours a week. The working hours on Saturdays are the same as other days. In winter, on an average, about 50 hours per week are worked. The pay is the same both in winter and summer. So it will be seen from the above statistics the rate of wages paid, per hour, are as follows:—

Carpenters and painters, 21 francs a week (17s. 6d.), which is a fraction over 3½d. an hour in summer, and 4½d. per hour in winter. Stonemasons and plasterers receive the same pay; but superior men in both avocations get as much as 27 francs a week (£1 1s. 8d.), which is just over 4d. an hour in summer, and 5½d. in winter. Plumbers are paid from 22½ francs (18s. 9d.) a fraction over 3½d. an hour in summer, and 4½d. an hour in winter, up to (top wages) 24 francs (19s. 2d.), hardly 3½d. an hour in summer, and just under 4½d. per hour in winter.

Bricklayers' wages are, curiously, lower than any other trades connected with building. They get 18fr. (15s.) a week, which works out at between 2½d. and 3d. per hour in summer, and halfway between 3½d. and 3d. in winter. Labourers have 12fr. (10s.), which is less than 2d. an hour in summer, and just under 2½d. in winter, whilst "dapper" men amongst them get 15fr. (12s. 6d.), which is a little over 2½d. an hour in summer, and in winter 3d. an hour.

It is very distressing to find the ancient wayside Calvaries in Brittany so fast disappearing. Hundreds of them have gone since my last visit. I happily rescued from a mason's yard into which they had been ruthlessly thrown, a couple of colossal ones carved in wood in excellent preservation and painted (each, probably, 250 years old). They stood, originally, near le Conquet, the Land's End of France. I got them both carefully conveyed home, and one of them now stands on a cross 40ft. high, on the lawn of my own residence at Exeter.

And now I must close. The R.M.S. *Avondale Castle*, after a capital run of little over four days from Southampton, has just arrived in the midst of the deep-blue bay at Grand Canary. As I look out of the port window at my elbow, Las



of an arbitrator under the Lands Clauses Act was not necessarily biased because during the pendency of the award he had given evidence in favour of one of the parties in another inquiry, although one of the judges threw out more than a word of warning that an umpire in such a case should inform the parties as to the facts. There had been many ignorant or half-informed critics who, taking particular cases, had made out a case against professional umpires as having some rough-and-ready method by which, in spite of evidence, they settled matters brought before them; but the fact that surveyors as a profession were so thoroughly trusted in matters of valuation was a sufficient answer to this criticism. The duty of a surveyor, whose report formed a kind of rampart behind which a trustee could find safety and security, was a delicate and even a dangerous one, and, in case of mistake—negligent mistake, of course—involved a heavy liability. In the case of counsel or physicians, whose fee was an "honorarium" and not recoverable, it was probable that liability was only incurred to the extent to which one was liable who renders a gratuitous service, although, as the author pointed out later on, even in that case a man was bound to exercise ordinary care and skill. "A man who enters upon the exercise of a public profession contracts," said Mr. Wheeler, "to bring to bear upon his function, whatever it may be, honesty and integrity, of course, and, further, there is an implied warranty that he is skilled and reasonably competent for the task he undertakes." No one undertook more than this by the mere fact of employment. He could not be bound to possess an unclouded judgment or consummate skill; but, in the words of the lawyers, "readiness and willingness" to discharge his duties imported capacity to discharge them efficiently. Mr. Wheeler proceeded to give several cases in which "negligence" had been charged, mainly for the purpose of showing that whilst in the witness-box expert evidence had been very widely criticised, often in ignorance, yet the Legislature had intrusted many important duties to experts in an advisory and even a judicial sense, while the faith reposed in them by the public was of the widest and broadest character. So should be their responsibilities and liability for failure of duty, negligence, or ignorance.

A short discussion followed, in which Mr. Howard Martin, Mr. G. R. Crickmay, Mr. D. Watney, Mr. G. Corderoy, and Mr. Northcroft took part. In response to the latter speaker, Mr. Wheeler said that in case of liability the amount of the fees was by no means the measure of damages. In fact, it had nothing whatever to do with the matter. The vote of thanks having been carried unanimously, the meeting then adjourned.

#### SPECIFICATIONS IN DETAIL.\*

THERE are few treatises on specifications, and these are so incomplete or so superficial in their character as to be of little practical use to architects. In a new work under the above title, Mr. Frank W. Macey, architect, attempts to supply the want. As to whether he has satisfactorily done so, only those who have carefully examined the contents of this comprehensive volume can express an opinion, for a work of this kind can only be tested by many practical applications. As far as we have been able to examine the contents of the work and the system on which it has been compiled, we believe it will be found very helpful by a large number of young architects who have not yet been able to prepare a workable and complete specification, or who are in some doubt as to the best system and the proper wording of clauses. One valuable feature of Mr. Macey's work is the large number of diagrams, marginal sketches, and details which illustrate every page of the work, and which assist to make it a handbook of workmanship and details as well as of specification clauses. We find the clauses, as a rule, are sufficient. The author explains many of them by footnotes or paragraphs close to the clause itself, which is very necessary in many special cases. The clauses describe the usual methods employed, and the sizes and dimensions are those for a superior class of work; but smaller sizes and thicknesses are often given in brackets for less substantial work. Of course, every architect ought to be able to use his own judgment in filling in the

proper scantlings and thicknesses. To examine a few of the trades. Taking the Bricklayer, we find the first clause devoted to hollow walls. The author specifies a 2½ in. cavity, and he is quite justified in saying all external walls should be built so. In brick districts in the South and West of England the cavity is usually 2½ in. The author specifies "heavy galvanised cast-iron wall ties about 8½ in. by 2½ in. by ¾ in.," with a dip in centre and forked ends spaced 3ft. apart alternately to every third course of brickwork. Perforated air bricks are to be placed under the eaves-course, and similar air bricks at the base of wall for ventilating the cavities. Over the door and window frames 4lb. lead is to be placed in the cavity, forming a gutter, turned down at each end, so that the frames may be protected from any water that may find its way in. In a note the author says, "It is better to make the outer casing the lesser thickness, so that the inner casing may be of sufficient strength and thickness for bedding the joists and roof-timbers upon." A 9 in. wall would have both inner and outer casings half-brick thick; in a 14 in. wall there would be a 4½ brick outer casing, and a 9 in. inner casing. For many reasons we prefer the thicker casing to be on the outside, especially for buildings in which deep brick reveals and jambs are essential, and if the wall thicknesses are properly tied together (we prefer wrought-iron or galvanised ties, well forked at the ends), the inner half-brick casing is ample for carrying the weight of the two floors. Of course, for buildings of several stories, and carrying heavy floors, at least a one-brick wall is required. Mr. Macey says, in a hollow stone wall where the greater thickness is necessarily outside of cavity, the joists, &c., must go through the cavity and bear on the solid stone outer wall. This is certainly not desirable, as the timber in the cavity would soon decay; nor is it necessary if the half-brick inner casing is well built and tied to the outer walls.

About bricks, much useful information is given. It will not be generally accepted that "kiln-burnt are better than clamp-burnt bricks." Nor will the architect be disposed to act up to the suggestion that "rubbers" are soft bricks, and do not stand the weather so well as bricks moulded and carved before burning. The different qualities of lime are noticed, and a clause is given for each. One clause runs: "The lime to be freshly-burnt hard grey chalk (stone) lime from Halling, Dorking, or Maidstone"; another, "The lime to be freshly-burnt blue lia lime from Barrow, Rugby, or Whitby." The latter is, of course, more hydraulic, but expensive. For damp situations the lime from Halkin Mountain or Aberthaw is recommended as the best and the most powerfully hydraulic. Clauses are given for selenitic lime or cement, lime mortar, gauged lime mortar, hair mortar, blue or black mortar, cement mortar, putty. Much useful information is given in this trade as to the requirements of the London Building Act, and the schedules of thicknesses for the three classes of buildings are quoted, so that no reference need be made to the Act itself. Various kinds of sleeper walls for joists and paving are mentioned, with sketches of parapets, eaves, circular work, pipe channels, inverts, vaults, dry areas, flue-pipes, chimney stacks, ventilating flues, arches, &c. Many special kinds of walling, retaining walls, and storage reservoirs are usefully introduced, but the clauses for terracotta and faience are inadequate. The carpenter, joiner, and ironmonger occupy by far the larger portion of the book, and we have many detail suggestions for such things as floors, fire and sound-proof timber floors, flooring of particular kinds (rebated or fillistered), grooved and tongued yellow Gelfe deal in batten widths, with several alternative clauses for them. A model clause for reception-room double flooring is useful, in which lin. wrought (or rough with edges shot) is laid on joists, and yellow Gelfe deal counter-flooring in batten widths, laid folding, to be rebated, grooved, and tongued, of 1 or 1½ wrought Austrian Trieste oak, or Hungarian Fiume oak, or Russian Riga oak, or Dantzic crown Memel oak, or wainscot oak or Moulmein teak, or American pitch-pine in certain widths. Then we have many alternative clauses for roofs, flats, domes, and skylights, illustrated by numerous types of roof. The clauses for many special kinds of casements, and numerous sections of sills, and frames, transoms and heads are of value. Half-timber work, so generally omitted from works on this subject, is dealt with. The Smith and Founder is prefaced by

data on wrought and cast iron, and clauses on rolled iron joists, plates, bars, rivets, &c. Specifications for wrought-iron and steel joists and girders are useful; iron roofs of various spans are sketched, corrugated iron roofing, stanchions, and columns of cast iron, with their relative strengths, and section, and connections, are described. Some useful clauses on stoves and ranges will be found. The subject of heating is described, and various systems are illustrated, a branch of specification which is often very imperfectly dealt with or is intrusted to the engineer. Stables and fittings form part of this trade. Plans of stalls and cow-houses are given in addition to clauses. Under Plumber the principal sanitary fittings are described, and the clauses refer to hydraulic rams, cisterns of galvanised iron and lead, hot-water supply. The latter is illustrated by diagrams showing hot-water circulation in connection with close fire-range, high-pressure boiler and cylinder and different arrangements are shown. The mode of laying zinc flats, jointing of sheets, and other items is described. Electric lighting forms a useful addition, and the wiring of buildings is generally described, and clauses given. This is a branch which was generally left to the electrician. The information and clauses, with the aid of the diagrams, will be of value to architects, though a few of them are rather ambiguous. A form of tender is given at the end, and a very full index, which will render the volume of much value to all professional men who wish for information or precedents in writing their specifications.

#### THE ENGINEERS' YEAR-BOOK.\*

WE have received from the publishers (Messrs. Crosby Lockwood and Son, 7, Stationers' Hall - court, London), a copy of the fifth year's issue of this indispensable daily reference-book for engineers. The volume is published at the moderate price of 8s. In his preface to the current issue the author states, "besides general corrections—necessitated chiefly by the annual alterations in rules and regulations—the book has again been thoroughly revised throughout, and a large number of entirely new pages added, bringing the total up to 700 as compared with 590 in the first or 1894 issue," and using 850 engravings for the illustrations.

The work is a development on the lines of Molesworth, Trautwine, and D. K. Clark. Whilst the general contents of the book are of a high order, the range of matter included in the volume is very wide. A great point in the book is that it supplies explanations and directions, as well as formulæ and tables, and it is arranged to answer the demands of mechanical as well as civil engineers. The author is in a responsible position, and he has access to very useful and not very readily attainable information, and in his comprehensive, complete, and accurate volume has brought together with great skill all the technical professional information which an engineer has to use day by day.

The new station for the City and South London Railway at St. Mary Woolnoth, Lombard-street, E.C., is being designed by Mr. Sidney R. J. Smith, who, as architect, is working in conjunction with Sir Benjamin Baker and Mr. David Hay, the engineers. Mr. Smith will be responsible for all the work above ground, and he is adopting a style in harmony with the church of St. Mary Woolnoth, which was designed by Nicholas Hawksmoor. The station will be under the church.

The plans for the new municipal buildings to be erected in Govan have been passed in the Dean of Guild Court. The buildings will be situated in the corner of Govan and Summertown Roads, and will include offices for burgh purposes, council chambers, a large and a small hall, and the necessary committee and other rooms. The different frontages are: To Govan-road and Carmichael-street, each 157ft. 3in., and to Summertown-road, 240ft.; to Merryland-street there will be two frontages of 71ft. and 86ft. 6in. respectively, there being a space left in the middle for future extensions. There will be a large hall capable of accommodating 2,000 persons, and a smaller hall which will seat 500 people, with the usual cloak and retiring rooms adjacent. The main entrance for officials and commissioners is from Govan-road, as also is the entrance to the board-room. The buildings will cost over £30,000. Messrs. Thomson and Sandilands, Glasgow, are the architects.

\* The Engineer's Year-Book of Engineering Formulæ, Rules, Tables, Data, and Memoranda for 1898. By H. R. Kempe, A.M. Inst.C.E. Fifth year of publication.

\* Specifications in Detail. By FRANK W. MACKEY, Architect. London: E. and F. N. Spon, Ltd., Strand.

## OBITUARY.

MR. WILLIAM SPOONER TILL, who for nearly forty years ably and faithfully filled the office of city surveyor of Birmingham, died on Tuesday in his 68th year. For a long time Mr. Till's health had been failing, and his retirement from the surveyorship was due to this cause. Recently he had suffered from insomnia, and had an attack of influenza a few weeks ago. Mr. Till was a native of Birmingham, and was educated at King Edward's School. He left school at the age of sixteen, and was articled to Mr. John Piggott Smith, who was surveyor to the Commissioners under the Birmingham Street Acts, a body who were in some sense the predecessors of the town council. In 1851 Mr. Piggott Smith became borough surveyor to the town council, and so continued until 1857, when he was succeeded by his assistant, Mr. Till. Mr. Piggott Smith had received £600 per annum, but Mr. Till, then twenty-seven years of age, commenced at only £300. Under its new municipal government, Birmingham began to move forward with rapid strides, and numerous works of street improvement and sewerage were undertaken. In these the borough surveyor was both the adviser of the Corporation and its executive officer. The duties of his department grew until his position became that of the head of a large staff. The salary of the office, which had been increased from £500 to £600 in 1867, was raised to £700 in 1870, and to £1,000 in 1877. In the latter year also the Tame and Rea District Drainage Board came into operation, and Mr. Till received from that body the appointment of engineer to the sewerage works, which had been mainly constructed from his drawings, at a salary of £200, afterwards raised to £400. Mr. Till possessed, says the *Birmingham Post*, untiring industry and a quiet grasp of the subjects with which he was called upon to deal which made him a most efficient officer. He established so high a reputation for fairness and sound judgment that his advice was frequently sought in disputes and questions of drainage difficulty arising in connection with the suburban sanitary authorities. He saw the bounds of the city enlarged, and the appearance of its central streets wholly changed. When Mr. Till first took control of the surveyor's department, the heart of the town was little better than a network of narrow streets and gulleys. Beyond New-street, High-street, and Bull-street there was not a pavement in the place but what was set with "petrified kidneys." In Hagley-road and similar thoroughfares the paths were strewn with gravel, but the stones were of a great size. Some streets were in such a state as to be positively dangerous, and in not a few streets the footpaths were raised a considerable height above the road. The paving of the footpaths, the alteration of the street lines, and the laying-out of the sewerage afforded an immense amount of work. The principal street improvements carried out under Mr. Till's superintendence were the making of Albert-street, Stephenson-street, and John Bright-street; the widening of Colmore-row; the formation of the present line of Edmund-street, between Congreve-street and Livery-street; the doing away with the level crossing in Duddeston Mill-road; and the making of Station-street and Holiday-street in connection with the London and North-Western and Midland Railway extensions. The length of public sewers constructed was over 199 miles. The formation of the drainage district, in connection with which Mr. Till also rendered services, took place in 1877. The district includes, besides Birmingham, Smethwick, Balsall Heath, Harborne, Saltley, Aston Manor, Handsworth, Aston Union (contributory place of Aston), King's Norton Union (contributory places of King's Norton and Northfield), West Bromwich Union (contributory place of Perry Barr), and the borough of Sutton Coldfield. In the construction of these works, and in the acquisition of land, Mr. Till showed himself an able engineer and a no less excellent negotiator. Mr. Till was a widower, but leaves a son—Mr. Guy Till, who is engaged in the surveyor's department of the Birmingham Corporation—and five daughters.

MR. GEORGE HENRY GRIMWOOD, J.P., head of the firm of Messrs. Grimwood and Sons, builders and contractors, of Sudbury and Ipswich, died on Monday at Brighton, after a long illness, aged 52 years. Mr. Grimwood was an alderman and justice of the peace for Sudbury, and had twice served as mayor of that borough. His firm erected the new post-office at Ipswich, and many other buildings in the Eastern Counties.

## PROFESSIONAL AND TRADE SOCIETIES.

EDINBURGH ARCHITECTURAL SOCIETY.—At a meeting of this society, held in Dowell's Hall, on Wednesday, February 16th, Mr. William M. Cumming, A.R.I.B.A., president, in the chair, a paper was read by Mr. J. E. Forbes, intitled "Normandy." Mr. Forbes gave a very interesting account of his tour, and sketched the general characteristics of the towns in Normandy, especially pointing out the peculiar beauty of colour pervading the landscape. Rouen was specially mentioned as being exceptionally artistic, showing marked examples of 14th and 15th-century architecture. Passing on to Lisieux, Mr. Forbes mentioned the timber-framed houses as worthy of notice, comparing favourably with like work in Chester. The paper was profusely illustrated by limelight views.

REUNION OF ARCHITECTS AT CARDIFF.—The annual dinner of the Cardiff, South Wales, and Monmouthshire Architects' Society was held on Saturday evening at the Angel Hotel, Cardiff, when a large company of architects attended from various parts, the guests including Professor Aitchison, R.A., P.R.I.B.A., Mr. H. V. Lanchester (the successful designer in the competition for the proposed municipal buildings in Cathays Park), the Mayor of Cardiff (Alderman Ramsdale, J.P.), Canon Thompson, the Deputy-Mayor (Alderman David Jones, J.P.), Mr. Lewis Williams, J.P. (chairman of the Cardiff School Board), Councillor E. Thomas, J.P., and Mr. Lascelles Carr, J.P. The chair was occupied by the president of the society, Mr. C. B. Fowler, F.R.I.B.A. Mr. E. W. Corbett, M.S.A., gave the toast of "Our Pastors, Legislators, and Defenders." Captain W. H. Caple, of the Severn Volunteer Division of the Royal Engineers, acknowledged the toast. Canon Thompson, D.D., submitted the toast of the evening, and expressed the hope that after this lapse of three years the annual dinner would be continued in its proper course. The Chairman, in replying, dwelt upon the state of the South Wales Society, which was formed in 1890, and although the membership had decreased from 28 to 18 last year he was pleased to state that from the number of applications and the various letters of inquiry they hoped that in a short time it would be greatly increased. Professor Aitchison, R.A., also responded. Mr. Lascelles Carr submitted the toast of "The Governing Bodies." The Mayor (Alderman Ramsdale), the Deputy-Mayor (Alderman D. Jones), and Mr. Lewis Williams replied. Mr. Edwin Seward, F.R.I.B.A., submitted the toast of "The Master Builders," which was replied to by Mr. J. E. Turner (president of the Master Builders' Association), and "The Visitors" completed the list.

SANITARY INSPECTORS' ASSOCIATION.—The 15th annual dinner of this association was held at the Holborn Restaurant on Saturday evening. Sir John Hutton, the president, occupied the chair, and the company numbered about 200. The President, in proposing "Success to the Sanitary Inspectors' Association," said its 700 members included many sanitary inspectors throughout the country. In London there were only some 200 inspectors for sanitary matters, and that was a totally inadequate number, seeing that London possessed some 600,000 houses, so that each of its sanitary inspectors had under his charge 3,000 houses and 25,000 persons. The population test was even more unfavourable. In one district, where 296,000 persons resided, there were four inspectors, each having an average population of 74,000 persons under his charge. Their remuneration, too, was totally inadequate. Only nine of the 200 inspectors in London were in receipt of salaries of upwards of £200 per annum, and 112 received less than £150 per year. The London County Council, in view of these facts, was now considering the advisability of insisting on local authorities increasing the remuneration of sanitary inspectors in order to insure a good class of men being attracted to the service. He presented testimonials on behalf of the association to Mr. C. W. Raymond, hon. treasurer, and Mr. W. W. West, past-chairman of the association, in recognition of their services. Each received an illuminated address, accompanied in Mr. Raymond's case with a gold watch, and in that of Mr. West with a writing-case. Other toasts followed.

THE SOCIETY OF ARCHITECTS.—At the monthly meeting of the Society of Architects, held at St.

James's Hall, Piccadilly, W., last (Thursday) night, Mr. Walter Emden, J.I., L.C.C., the president, in the chair, Mr. Ernest William Crickmay, of 5, Rood-lane, E.C., was elected a member. The President announced that the annual dinner of the society will take place in London on Thursday, April 21st. Mr. G. A. T. Middleton, A.R.I.B.A., then read a paper, illustrated by numerous lantern views, entitled "Egypt; the Birthplace of Architecture," which is fully reported on page 261.

## CHIPS.

Mr. Herbert Spencer's presentation portrait has now been finished by Professor Herkomer, R.A., and will be exhibited at the Royal Academy this year.

For the erection of a new district church in Peterborough, Mr. W. Boyer, of that city, has been appointed architect, and has been instructed to prepare plans for a church to seat 500 persons.

The picture entitled "Sleep," by Mr. Frank Bramley, A.R.A., which attracted some attention at the Royal Academy last summer, has been bought for the permanent collection of the Carnegie Art Gallery, Pittsburg, U.S.A.

The First Commissioner of Works (the Right Hon. A. A. Douglas, M.P.) has declared that on and after 1st April next no fees will be demanded for admission to Glasgow Cathedral.

A mansion at Rivington, near Bolton, erected many years ago by Mr. C. J. Stonor, along with 150 acres of the surrounding land, and covering a considerable frontage of the south side of the lower lake, has been purchased by a couple of Lancashire poor law authorities for the purposes of a large institution for the reception of lunatics and imbeciles.

The Rochdale Board of Guardians have decided to build a series of cottage houses for children on the workhouse grounds, at an estimated cost of about £11,500. Provision will be made for 146 beds.

One of the windows in the Guildhall at York is about to be filled with stained glass as a memorial to the late Sir Joseph Terry. The subject will be: King Edward IV. assumes the badge of the House of Lancaster in order to induce the Lord Mayor, John de Gisburne, and citizens to allow him free passage through the city (1471).

Permission has been granted to erect the proposed memorial to the late Sir Charles Craufurd Fraser, V.C., in the Cavalry Church at Aldershot. Mr. George E. Wade, sculptor, has been commissioned to execute the work.

The London County Council have just converted the roadway crossing the viaduct on Hampstead Heath, and running from the Spaniards-road to a spot near Hampstead Heath Railway Station, into a very fine cycle track.

Considerable additions are being made to the head offices of the Gas Light and Coke Co., Westminster, and special consideration has been given to the ventilation, which will be carried out on the Boyle system.

The sewerage of the village of Callompton has just been completed for the Tiverton rural district council. Mr. Barrons has been the engineer, and Mr. Shaddock the contractor.

A movement has been set on foot for a memorial decoration of the school-room of the King's School, Canterbury. It is proposed to retain every piece of oak at present in the room, including the old oak rail (originally part of some cathedral pews), on which so many names and initials have been cut. It is hoped to combine with the new work some of the old oak panelling that belonged to the previous schoolroom (part of the old Almonry Chapel), which was in use from the 16th century down to about 1850.

The River Wear Commissioners have had erected, in order to meet the demand at the Sunderland Docks for warehouse accommodation a new warehouse and transit shed. The building, which is 160ft. long and 46ft. wide, contains three stories, and has been built by Mr. T. P. Shaftoe from plans prepared by officials of the Commission.

The memorial bust of Lord Randolph Churchill, which has been executed by Mr. Storey, A.R.A., for erection within the precincts of the House of Commons is ready to be placed in position; but some structural alterations have to be made for its accommodation, and it will not be inaugurated before the Easter recess.

Colonel A. J. Hepper, a Local Government Board inspector, held an inquiry at Batley Town Hall on Friday in connection with the corporation's application for sanction to borrow a sum of £13,494 for works of surface-water drainage. The borough surveyor, Mr. O. J. Kirby, represented the corporation.

## Building Intelligence.

**BOURNE, LINCOLNSHIRE.**—The chancel of Bourne Abbey Church was reopened last week after restoration from plans by Mr. J. C. Traylen, A.R.I.B.A., of Stamford and Peterborough. The chancel, as it stands, has no original relation to the building: it is the outcome of necessity. In its entirety, the nave of the Abbey Church extended beyond the space now over-built by the chancel, which was built simply to repair the partially-demolished structure. The roof, as thus made, was one of stolid ugliness. The ideal restoration would have been the continuation eastwards of the grand roof of the nave; but, quite apart from financial considerations, this could not be undertaken, as the building and roof were in a sound condition. The walls and stonework of the chancel have been cleaned down and replastered. The memorial mural tablets have been raised to give way to the warm oak-panelling, which now extends the entire length of the chancel; the seating is of English oak. The eight terminals of the new choir benches carry emblems of the Sacrament of the Lord's Supper. The new screen dividing the nave from the chancel is of English oak tracery, bearing effigies of the four evangelists, with their emblems. Other new features are the Communion rails, prayer-desk, and four three-light brass pendants bearing incandescent lights. The pendants are the work of Messrs. Elgood, of Leicester. The builders' work has been carried out by Messrs. Roberts Bros., of Stamford. The carved work—the emblems and the screen—are by Messrs. Harry Hems and Sons, Exeter.

**EDINBURGH.**—The consecration of the new synagogue, Graham-street, by the Very Rev. Dr. Adler, Chief Rabbi, from London, took place on Sunday week. With the £4,000 the Jewish congregation received from the corporation for their old synagogue in Park-place they purchased the New Greyfriars Free Church, Graham-street, for £2,400, and the balance of the money has been expended in making the interior suitable for the purposes of Jewish worship. Formerly the pulpit stood at the west end of the church, and the seats were arranged accordingly; but the fact that the ark and the pulpit had to be at the east end necessitated an entire reconstruction of the interior. The centre of the design is a reading desk set on a platform in the centre of the area. It has brass rails. The pews slope upward from it on the north, south, and west sides. As no gallery is available for the ladies, space has accordingly been appropriated on the west side of the synagogue, raised, and inclosed with a light brass grill of Oriental pattern. It has a separate entrance. On the east side, on a raised dais and set close to the wall, is the ark. It takes the form of an Oriental baldachino, with pillars at the opening, and having overhead a golden dome and lantern. It is painted in cream, gold, and green colours. The synagogue is seated for 250 men and 130 women. The architect for the reconstruction was M. N. Thomson, Leith.

**GUNNERSBURY, W.**—The new chancel at St. James's Church has just been consecrated. Ten years ago the nave and aisles were built, part of the nave being used as a temporary choir and chancel. The new chancel is the same width as the nave, and measures 40ft. in length from the chancel arch to the eastern wall, and the height from floor of choir to the apex of ceiling is 42ft. On the north side are the vestries and organ-chamber, with open arches towards the chancel and nave aisles. On the south side of chancel, facing the High-road, it is proposed to add at a future time a south aisle, which may be used as a morning chapel; but at present the arches are filled in with a temporary wall. The building has been carried out in the Early Pointed style, in harmony with the rest of the church; but the work in the arches, traceried windows, and credence is somewhat richer in character. The oak work of the screens and reredos is in a later style of church work. In the east wall of the chancel there are six large lancet lights, 17ft. high, in pairs, with circular cinquefoil and quatrefoil lights over. These windows will ultimately be filled with painted glass; but at present only the two centre lights are so completed. An oak reredos has been erected at the back of the altar, and is divided into nine panels, with cusped and traceried heads and carved and enriched cornice. The screen dividing the chancel from the nave is of light, open oak work. The

nave of the church, owing to the removal of temporary chancel, has had extended pew accommodation added, and the pulpit has been altered and rearranged to suit its new position against the south pier of the chancel arch. The old choir stalls and altar rail have for the present been fitted up in the new chancel, and the existing organ has been moved to its new position on the north side. The building work has been executed by Messrs. Dorey and Co., of Brentford; the oak screens and reredos are by Mr. Caldcleugh, of Durham; the tile floors by Messrs. Carter, Johnson, and Co. The whole of the works have been carried out from the designs and under the personal supervision of the architect, Mr. Howard Chatfield Clarke, of 63, Bishopsgate-street Within. The cost has been about £2,750.

**NEWCASTLE-UNDER-LYME.**—The Bishop of Lichfield recently opened the new institute at the corner of Hassells-street and North-street. It is of red brick, with stone dressings, the style being Late Gothic. There is a low tower over the main entrance, and the principal windows are filled with leaded lights. The large hall or church-room is 63ft. by 28ft., and 25ft. high to the principals. This room is fitted with platform and movable seats, and will also be used as a gymnasium. On the other side of the main corridor are a classroom 30ft. by 21ft., a reading-room 16ft. by 22ft., and a billiard-room 30ft. by 22ft. When required, these three rooms can be used together, being separated by sliding partitions. A smoking-room is situated upstairs, and a kitchen, heating chamber, and lavatory accommodation are also provided. The corridors and other portions of the building have tiled dados. Messrs. R. Scrivener and Sons, of Hanley, have been the architects, and Mr. S. Wilton, jun., of Newcastle, the builder, Mr. E. Peake, of Fenton, putting in the heating apparatus. The total cost has been £3,000.

**ROYAL PALACE HOTEL, KENSINGTON.**—Extensive additions have just been completed, including the Empress rooms, which consist of the largest and best arranged ballroom in London, which is decorated and furnished throughout. The whole of the work was carried out in eleven months. Messrs. Archibald Smith and Stevens supplied the lifts, the Coalbrookdale Company the grates and entrance porch, Messrs. Charles Knowles and Co. the costly Japanese papers, Messrs. Jeffrey the leather papers, Messrs. Graham and Banks the decorations. Messrs. Legg and Son were the architects, and Messrs. Bywater the builders. The clerk of works was Mr. Rowse.

**WAKEFIELD.**—The new county hall for the West Riding County Council, built on an isolated site in the centre of the city at a cost of £120,000, was opened on Tuesday. The site has an area of 45,156 square yards. The architects, Messrs. Gibson and Russell, of Gray's Inn, W.C., have adopted a Renaissance treatment, the chief features being a dome rising to a height of 130ft. over the main entrance at the corner of Broad-street and Cliffe Parade, and a loggia of six arches in the former street. The main staircase is of Hopton stone and leads to the council chamber, 40ft. by 40ft., and ante room, 26ft. square, both apartments being 24ft. in height. The council chamber is panelled in mahogany and floored with oak blocks, the walls and domed ceiling above the dado being finished in modelled and coloured plaster work. A library, committee rooms, luncheon room, and kitchen are also provided.

In Paisley Dean of Guild Court on Friday, plans of a new eye infirmary to be erected by Provost Mackenzie as a Jubilee gift to Paisley were passed. The building will be of stone, and two stories in height. The site is Mansion House-road. The cost will be about £4,000.

At a meeting of the Godalming Book Club at the Grosvenor School in that town, on Tuesday evening, Mr. Samuel Welman, architect, read a paper on the parish church, in which he traced its history from the days of Ranulf Flambard, Bishop of Durham and Chancellor to William Rufus, until the present time.

The London County Council adopted, on Tuesday, a recommendation of a committee that the erection of a block of working-class dwellings on the Boundary-street area should be intrusted to the Works Department against a hostile amendment by 53 votes to 45. The architect's estimate of cost is £13,715. After a brief discussion it was agreed to contribute £5,000 to the fund for the acquisition of Churchyard Bottom Wood, Highgate.

## COMPETITIONS.

**BISHOP AUCKLAND.**—Sir Henry Burdett, to whom the committee had referred the matter, has adjudicated in favour of the plan of Mr. James Garry, of West Hartlepool, for the erection of the Bishop Auckland District Cottage Hospital, projected by Lady Eden.

**HARROGATE.**—The committee of the Harrogate School of Art have received the report of the adjudicators, Messrs. Woodhouse and Willoughby, architects, Manchester, upon the competitive designs for a new technical institute for Harrogate, which is estimated to cost £5,000, in addition to the site. The committee have awarded the three prizes of £20, £10, and £5 as follows:—1, Mr. W. J. Morley, architect, Bradford and Harrogate; 2, Messrs. Bland and Brown, architects, Harrogate; and 3, Mr. J. E. Marshall, architect, Harrogate.

## CHIPS.

The urban district council of Herne Bay, at an emergency meeting, have decided to borrow £20,000 to repair the damage to the sea front caused by the great gale in December.

An adjudication in bankruptcy has been made in the case of Harry George Wilkins, of Bristol, builder.

The Marquis of Exeter opened on Thursday in last week a parish house erected in Clare Market in connection with the Church of St. Clement Danes, Strand. The building has been erected upon a piece of ground known as "the island," the gift of Mr. W. F. D. Smith, M.P., at a cost of about £4,000, exclusive of the site, which is valued at about £3,000. It contains a hall with seating accommodation for about 250 persons, and four other rooms, which are to be used for the purposes of a crèche, men's club-room, dining-hall, classrooms. Messrs. H. and P. Curry were the honorary architects, and Mr. James Carmichael was the builder.

The Bishop of Rochester took part on Thursday last in the reopening and dedication of St. Mary Magdalen, Massinger-street, Old Kent-road. The renovation of the church, vicarage, and schools has cost £3,700.

At Hollingbourne, Mid-Kent, on Friday, an organ which has been built and placed in the parish church by Messrs. Norman Beard, of London and Norwich, was dedicated by Dean Farrar.

At St. Gabriel's, Warwick-square, Piccadilly, on Tuesday, Bishop Barry dedicated the reredos, altar-rails, and other decorations in the sanctuary, the cost of which (exceeding £2,500) has been defrayed by Lord Edward Pelham Clinton, Master of the Queen's Household. The subject of the reredos is the Crucifixion. The rest is *opus sectile*, and consists of types of our Lord as Prophet, Priest, and King, and of His Passion.

A mission and parish room in connection with the parish of Elmbridge was opened at Cutnall Green on Tuesday week. The room, which is close to the main road from Droitwich to Kidderminster, will serve many purposes, and at the rear there are ante-rooms and stores. Messrs. L. Sheppard and Sons, of Worcester, were the architects, and the work has been carried out by Messrs. Emus and Harris, of Droitwich.

The death is announced of Mr. Charles W. Campion, architect and surveyor, which took place at his residence in London-road, Neath, on Sunday, from pneumonia, after a brief illness. The deceased, who was 65 years of age, had lived at Neath for 40 years. His father was an artist, whose pictures were held in very high esteem. Until the formation of district councils took place, Mr. C. W. Campion was surveyor to the Highway Board of Neath Union. Mr. Campion's map of the works and collieries of South Wales is well known. He has left a widow and three daughters.

At Monday's meeting of the urban district council for Hoyleake and West Kirby purposes committee, Mr. Leslie H. Daspher, assistant to the city surveyor, Lincoln, was appointed assistant surveyor and assistant inspector of nuisances to the district, at a salary of £100 a year.

The Egyptian Government has signed a contract with Messrs. John Aird and Co. for the construction of barrages at Assouan and at Asuit, the work to be completed in five years, and payment to be made by instalments extending over 30 years. 19,031,065 million cubic metres of water will be stored. Mr. Garston is the engineer-in-chief. The actual cost of the barrages will be £2,000,000. Inclusive of interest, the total sum to be paid will be £4,800,000, dischargeable by half-yearly instalments of £80,000, extending over a period of 30 years. Messrs. John Aird and Co. have just ordered 3,000,000 barrels of cement in Europe, to be delivered in nine months.

CONTENTS.

Model Specifications.—I. . . . .	259
The Design of Theatres . . . . .	260
Top-Loaded Buildings . . . . .	260
Royal Institute of British Architects . . . . .	261
Builders' Clerks' Benevolent Institution . . . . .	261
Egypt the Birthplace of Architecture . . . . .	261
Expanded Metal in its Relation to Fireproof Construction . . . . .	264
Last Summer in Brittany . . . . .	265
East Finchley Congregational Hall and Schools . . . . .	267
Legal Liability for Professional Opinion . . . . .	267
Specifications in Detail . . . . .	268
The Engineers' Year-Book . . . . .	268
Obituary . . . . .	269
Professional and Trade Societies . . . . .	270
Building Intelligence . . . . .	270
Competitions . . . . .	270
The Building News Directory . . . . .	271
Our Illustrations . . . . .	271
Royal Academy Drawings, 1898 . . . . .	290
Engineering Notes . . . . .	290
Parliamentary Notes . . . . .	290
Stained Glass . . . . .	291
Correspondence . . . . .	291
Intercommunication . . . . .	292
Legal Intelligence . . . . .	293
Our Office Table . . . . .	293
Meetings for the Ensuing Week . . . . .	293
Latest Prices . . . . .	294
Trade News . . . . .	294
Tenders . . . . .	294
List of Competitions Open . . . . .	295
List of Tenders Open . . . . .	295

ILLUSTRATIONS.

- "BLAWITT," GRANGE-OVER-SANDS.—NATIONAL GOLD MEDAL DRAWING OF PULPIT IN ST. CHAD'S CHURCH, BIRMINGHAM.
- METROPOLITAN MUSIC HALL, EDGWARE ROAD.—NEW CRICKET PAVILION, DENSTONE COLLEGE.—TWO HOUSES AT CHESTER.—ISOLATION HOME AT CHALFONT ST. PETER'S.
- BRIGHTON ARTISANS' DWELLINGS.—PROPOSED PLANS FOR EAST FINCHLEY CONGREGATIONAL HALL AND SCHOOLS.—AN ALABASTER PULPIT.

Our Illustrations.

"BLAWITT," GRANGE-OVER-SANDS.

This house is the result of an alteration which gradually involved almost entire reconstruction of an old house belonging to the late Mr. G. W. Deakin. The general contractor's work was executed by Mr. Enoch Denny, of Grange-over-Sands, and the panelling of hall, dining-room, drawing-room, and billiard-room, and fine staircase up to the first floor by Messrs. Morrison, of Liverpool. The panelling and staircase were all executed in oak. The carving was executed by Mr. Carlisle, of Barbon, Kirkby Lonsdale. The architects were Messrs. Willink and Thicknesse, Liverpool.

PULPIT IN ST. CHAD'S, BIRMINGHAM.

This exceptionally ornate pulpit, originally belonging to the church of St. Gertrude, Louvain, was purchased by the Earl of Shrewsbury, and presented to the Catholic Church of St. Chad's, Birmingham. Though a work of craft rather than design, it is not without merit in the latter, its bold modelling compensating in a measure for the lack of plain surfaces. It is hexagonal in plan, with sunk panels in four faces, the depth of which reduces the internal measurement to 2ft. 4in. The balusters at angles stand clear, differ in design, and vary in plan from concave hexagonal to circular. Originally each had a terminal, as shown in illustration; but these have disappeared together with a similar, but larger, one from central pendant. In each face is a seated figure, in the round and remarkably well cut, representing St. Jerome, St. Gregory, St. Augustine, and St. Ambrose. Two joists from pier, 3in. by 4in., support the whole. The drawings illustrated were awarded a National Gold Medal at South Kensington last year, and are the work of Mr. Wm. Haywood.

THE METROPOLITAN MUSIC HALL.

This well-known variety theatre has just been rebuilt. It occupies the site of the previous "Metropolitan," which was erected in 1862 on the same parcel of land occupied by the "Old White Lion," a hostelry originally founded in 1524, when "Padynton" was but a small village on the Edgware-road. So late as the commencement of the present century Paddington numbered scarcely 2,000 inhabitants; to-day it is one of the largest Parliamentary divisions, with two members of Parliament and 120,000 population. Mr. C. Gray Hill, of Coventry, was the builder of the present new house, and Mr. Frank Matcham is the architect. The construction throughout is fireproof.

NEW CRICKET PAVILION, DENSTONE COLLEGE.

This building has recently been erected on a site adjoining the college chapel and overlooking the playing-field. It is built of red brick, with red sandstone dressings and green slate roof. The external woodwork is painted apple green. The terraces in front of the pavilion are intended to accommodate spectators. The work has been carefully carried out by the contractors, Messrs. Chamberlain Brothers, of Burton-on-Trent. The architect is Mr. Bertram Heywood, M.A.

SEMIDETACHED HOUSES, HOOLE ROAD, CHESTER.

THESE houses, which are being erected for Mr. Robert Bower, of Chester, are faced with Haydock Colliery pressed bricks, and the roofs are covered with Ruabon brown tiles, supplied by Mr. J. C. Edwards. The builder is Mr. Samuel Manley, Aston, near Nantwich, and the architect is Mr. Richard Hall, Bangor, North Wales.

ISOLATION HOME, CHALFONT ST. PETER'S.

THIS building, in course of erection, is the gift of Mrs. Deamer to the National Society for the Employment of Epileptics, and although one of the least in point of size, this home will be by no means the least useful in the working economy of the Colony. In style it will harmonise with the series of buildings already completed or now in progress at the expense of Mr. J. Passmore Edwards, who bought the estate and dedicated it to the objects for which it is now being put by this most useful and indefatigable Society. Rigid economy has had to be studied, and picturesqueness is obtained by the simplest means. The working drawings herewith photographed show the accommodation provided. Red brick and tiles, with stone sparingly used, are the materials employed. The heating is by Messrs. Haden. The builder is Mr. George Darlington. Mr. Maurice B. Adams, F.R.I.B.A., is the architect.

BRIGHTON ARTISANS' DWELLINGS COMPETITION.

THE drawings which we publish under this heading are those which were placed first out of nine sets in a competition confined to local architects, and adjudged by the sanitary committee of the Brighton Town Council. In making the award the corporation intimated that they did not intend to adopt the plans in their entirety. The joint authors are Mr. Thomas Garrett, M.S.A., of 30, Ship-street, Brighton, and Mr. W. E. F. Gillam, M.S.A., of 162, North-street, Brighton. There were two sites dealt with, one given to the town by the mayor, Sir John G. Blaker, in the Lewes-road, and the other jointly by Messrs. Daniel Friend and Henry Abbey, in Elm-grove. Messrs. Garrett and Gillam's scheme, as will be seen from the drawings, comprised two descriptions of dwellings; the first of two stories, with back office, containing living-room, kitchen, scullery, and three bedrooms; and the second of three stories, without back office, containing living-room or kitchen, scullery, and three bedrooms. Each house has its own w.c., &c., and is in all respects self-contained. The two-story houses were designed for the whole of the Lewes-road site and for a part of the Elm-grove site, and the three-story houses for the remaining portions of the Elm-grove site where necessitated by the levels of the land. The whole of the drainage is arranged to be kept outside the houses. The fronts are faced with red kiln bricks up to the first-floor level, and above same to eaves with fine rough cast and red kiln brick dressings. The roofs are slated. Forecourts are provided for each house, and open spaces at the rear in conformity to the by-laws. In addition to the usual drawings required, competitors had to take their own levels, and prepare priced detailed sets of quantities, showing the cost of the proposed buildings.

AN ALABASTER PULPIT.

THE church of SS. John the Baptist and Patrick, Felling, has been further beautified by the erection of a new marble pulpit, the gift of one of the members of the congregation, Mr. James McGuinness. The pulpit, which is here illustrated, is executed in richly carved, moulded, and polished alabaster, resting on a moulded base of Frosterley marble. The shaft above the base is richly traceried and groined, and has a carved band of conventional vine-leaves and grapes at the pulpit-floor level. On this rests the pulpit proper, which is octagonal on plan, each side of which has two panels, with traceried heads, and the whole is finished by a moulded cornice with battlements and carving.

The design is in the Decorated style, and harmonises well with its surroundings and the architecture of the church. This work has been carried out by Messrs. Emley and Sons, Limited, at their Marble Works, Hillgate, Gateshead.

ROYAL ACADEMY DRAWINGS, 1898.

THE last day this year for sending in architectural and decorative drawings to the Royal Academy is Monday, March 28th next.

We have to acknowledge many promises to lend us drawings for reproduction before they are sent in, to be illustrated in our pages after the exhibition opens as in former years. We shall be glad to receive other offers of drawings intended for the Royal Academy, and they should reach us as early as possible, not later than March 24th. Contributors who may wish us to receive and deliver their drawings for them to Burlington House (and we are willing to undertake this free of charge for contributors) must fix a label on the back of the picture and attach another by means of a string. These labels must give the title of the subject, and also the name and address of the sender. The labels can be obtained from the secretary of the Royal Academy of Arts, Burlington House, Piccadilly.

CHIPS.

The Peel Portrait Committee have resolved that, pending the removal of Mr. W. Q. Orchardson's canvas of the ex-Speaker to Burlington House for the Royal Academy Exhibition, it shall be hung in the dining-room of the Speaker's residence in the same position as it is intended to occupy permanently at a later stage.

Three large warehouses forming a stone-fronted block four stories in height have just been built in Golden-lane and Cripplegate-street, E.C., for an ostrich feather merchant. Three hundred girls and men will be employed in the building, which has been erected from plans by Mr. George Vickery, A.R.I.B.A., of 50, Gresham-street, E.C. Messrs. Lawrence and Sons were the builders.

The improvement committee of the town council of Brighton have been considering the question of altering the building by-laws now in force in the borough, one of which has recently been found to give the works committee some difficulty in their desire to deal effectively with the artisans' dwellings proposed to be erected in Elm-grove and on the Lewes-road. On the recommendation of the borough surveyor, they have resolved that the town clerk be instructed to draw up and submit an amendment to the by-laws, providing that in the case of buildings being three stories in height in consequence of a room in the roof, the thickness of the main wall of the building shall be 13in. for the first story, and 8½in. for the remainder of the building.

Another historical work will shortly be added to the decorations of the London Royal Exchange. Mr. Seymour Lucas, R.A., has completed his picture of William the Conqueror granting a charter to the City of London, and this will be placed in proper sequence in the Ambulatory. Mr. Sigismunde Goetze is engaged now on a representation of "King Richard III. being offered the Crown," and Mr. E. A. Abbey on a picture of "Lord Mayor Battlesdon giving his award in the Livery precedence dispute."

It has been decided by the directors of the Vale of Glamorgan Railway Company to construct a loop line so as to avoid for the present the viaduct at Porth Kerry, one of the pillars of which recently collapsed. The work has been intrusted to Messrs. Price and Wills.

The Bill for incorporating the Blackpool and Garstang Railway Company proposes to confer power upon a new company to construct a double line of railway commencing in Blackpool, on the east side of Park-avenue, and terminating at Catterall, by a junction with the London and North-Western Railway, over which running powers are sought to be exercised into Garstang and Catterall Stations. The total length of this railway will be 13¼ miles, and the engineer estimates that it can be constructed for £243,807.

An important change in the market arrangements at Smithfield has just been effected by the City Corporation at a cost of over £20,000. For some years past there has existed in the centre of Smithfield a fish market, but, owing to the position and surroundings, it has proved a failure. The corporation recently resolved to remove the market to a new site in the centre of the vegetable and flower section near the Farringdon Street Railway-station. A number of shops have been erected, and the new market has almost absorbed the vegetable section.



AN ALABASTER PULPIT.





Buckinghamshire

ISOLATION HOME CHALFONT ST PETER

FOR THE NATIONAL SOCIETY FOR THE EMPLOYMENT OF EPILEPTICS

Maurice B Adams F.R.I.B.A.  
ARCHITECT

MRS DEARMER'S

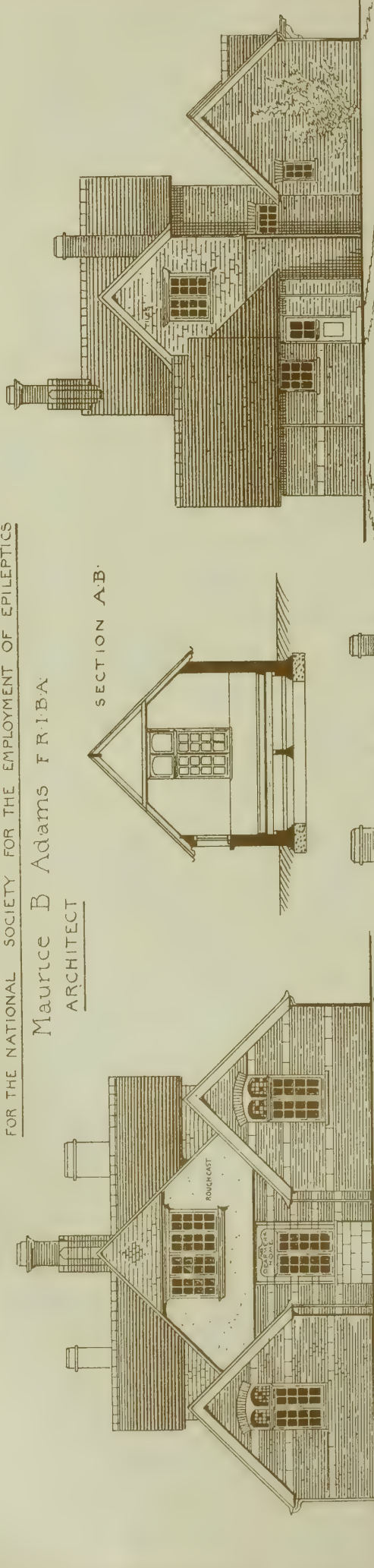

SIDE ELEVATIONS

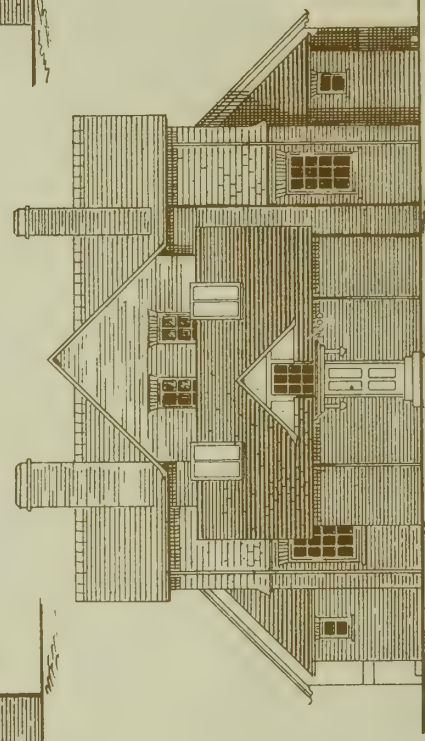

REAR FRONT



GROUND PLAN

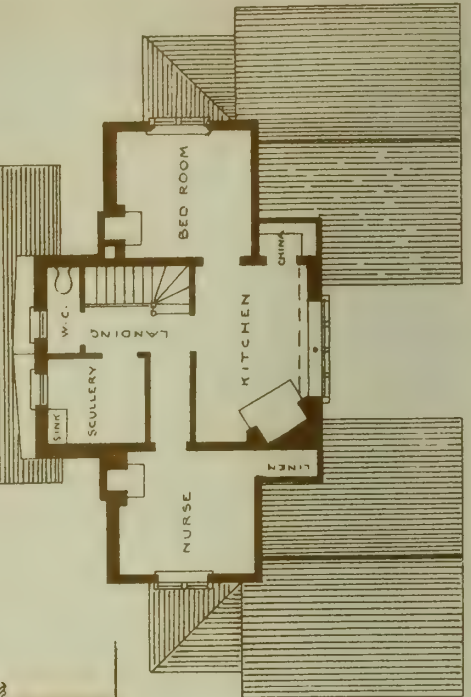

FIRST FLOOR

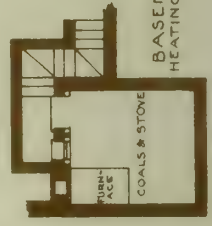

BASEMENT HEATING CHAMBER

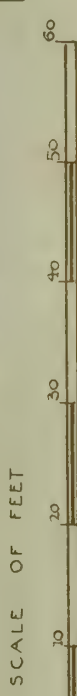



THE BUILDING NEWS, FEB. 25, 1898.

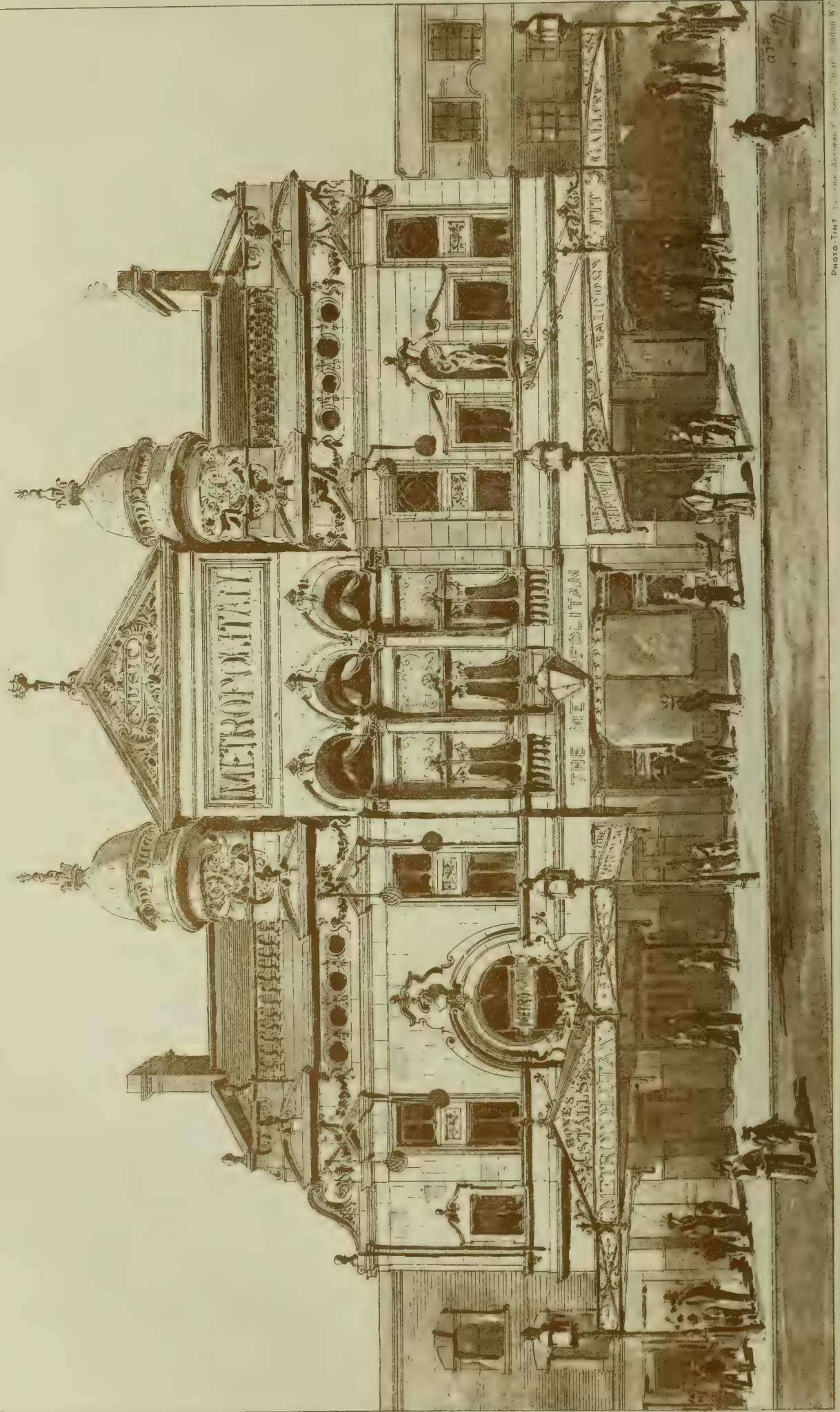
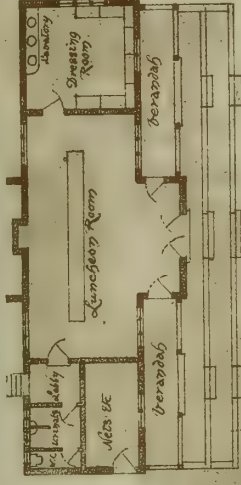

PHOTO-TINT BY MR. AKERMAN, 10, ST. JOHN'S W.C.

THE METROPOLITAN MUSIC-HALL, EDGEWARE ROAD, NW. FRANK MATCHAM, ARCHT.

THE BUILDING PEWS, FEB 25, 1898.

**B**  
"New Cricket Pavilion"  
Denstone College  
Staffordshire



Sketch 260.



Benjamin Heywood Architect August 1896

"PHOTO-TINT" by James Akerman 6 Queen Square London W.C.



THE BUILDING DEWES, FEB 25, 1898.



PHOTO-TINT by James Akerman & Queen, 2, Park Lane, London, W.1

TWO HOUSES HOOLE RD CHESTER RICHARD HALL ARCHT

24. 1897.







DAVID THE SEVERAL BIRMINGHAM

DETAILS OF TWO SIDES



ST. JEROME



VIEW FROM HALL

MADE ON THE

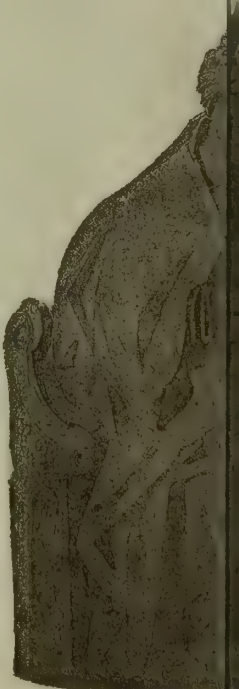

ST. C...

SKETCHED ON THE SPOT



SECTION OF  
KEY OF DETAILS  
OF VAULTING

NOTE: THIS PLATE WHICH IS  
OF OAKWOOD BROUGHT  
OVER FROM THE CHURCH  
OF ST GERKINDEL -  
BERMAIN - & PRESENTED  
TO THE CATHEDRAL  
CHURCH OF ST CHADS  
BIRMINGHAM (EVANGELICAL)  
BY THE EARL OF OAKWOOD

NOTE: THIS ORNAMENT HAS  
IN EACH CASE BEEN  
BROKEN OFF - & THE  
MOLDING WHICH PROBABLY  
CONNECTED THEM WITH  
DALVETER - LOST -

- ST AUGUSTINE -

MEASURED & DRAWN - MAY & JUNE -  
- REVISED NOV. 1896 -  
- William - Haywood -

COPIE -









"PHOTO-TINT" by James Akerman, 6, Queen Square London, W.C





DESIGN FOR THE DWELLINGS IN NEW 44<sup>TH</sup> ROAD

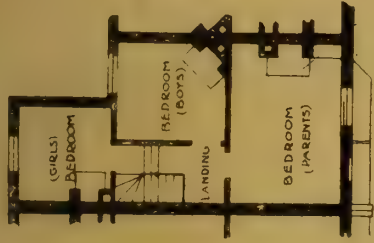
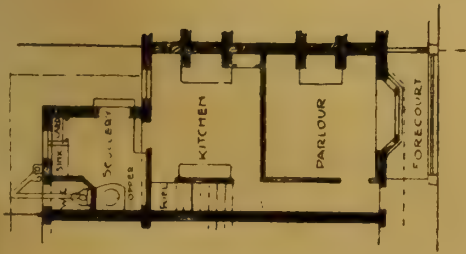

GROUND FLOOR PLAN

FIRST FLOOR PLAN

SECTION

FRONT ELEVATION

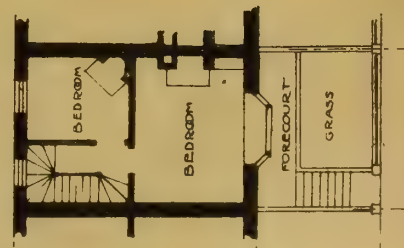
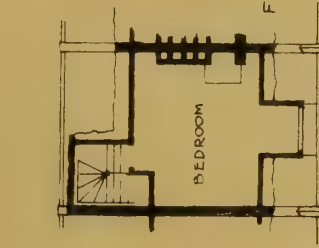
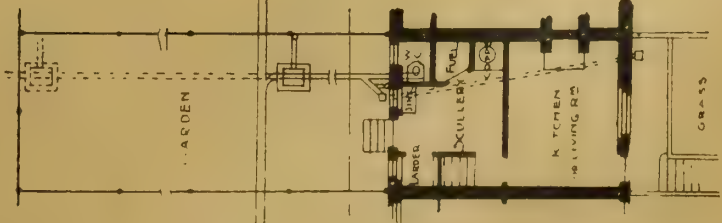

DESIGN FOR THE DWELLINGS FOR ELM GROVE AND ST. HELEN'S ROAD

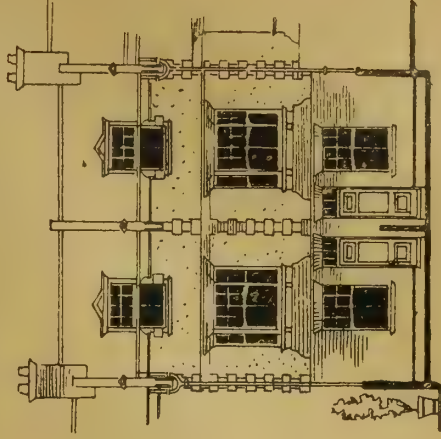
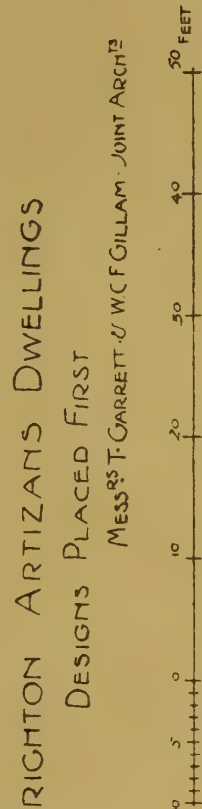

BRIGHTON ARTIZANS DWELLINGS  
DESIGNS PLACED FIRST  
MESSRS T. GARRETT & W. C. GILLAM, JOINT ARCHTS

SECTION

GROUND FLOOR

FRONT ELEVATION

## Engineering Notes.

**BIRMINGHAM.**—The directors of the Great Western Railway are considering a scheme for extension and improvement of their system between Birmingham and Wolverhampton. This scheme, if carried out in its entirety, will involve the expenditure of an enormous sum of money. The idea is to duplicate the metals at Birmingham between the north side of Snow Hill Station, from Charles-street and Handsworth Junction, from the company have acquired the whole of the land necessary for the project between Birmingham and Handsworth. The stations at Hockley, Soho, and Handsworth will be materially improved and enlarged, and the goods depots are to be remodelled and increased in size. When the land is prepared, the work of laying down the two additional lines of metals will be begun; but it is not expected that the undertaking will be completed under about two years. The general scheme is much larger, for it is in contemplation as soon as the Birmingham and Handsworth work is finished to double the lines between Snow Hill and Small Heath and between Handsworth Junction and Wolverhampton.

**CITY AND BRIXTON RAILWAY.**—The shareholders of the City and South London Railway Company have formally approved the Bill for incorporating a City and Brixton Railway Company, and for empowering the latter to construct an underground railway from the City and South London Railway, in Southwark, to Brixton Hill. The proposed company, if sanctioned, will utilise the present terminal station in King William-street and the existing tunnels under the Thames to the Borough, to be abandoned by the City and South London Company on the completion of the extension to Moorgate-street. The City and Brixton line will commence at a junction about 200 yards on the London side of the present Borough Station, and proceed down the Borough-road to St. George's-circus, and then into Lambeth-road and up Kennington-road, passing over the South London line at Kennington Park and on to a point about 30 yards beyond the Brixton Station of the Chatham and Dover Railway. An exchange station communicating with the City and South London Company's Denman-street Station will be made at Denman-street by widening the present tunnels. Passengers from this station will jointly use the lifts and station of the City and South London company. Another station will be at St. George's-circus, and at the Oval there will be an exchange station. The Brixton and City Railway Bill was read a second time in the House of Commons on Monday night.

**LEITH.**—The new swing bridge across the harbour of Leith, which connects the thoroughfares of Bernard-street and Commercial-street, was opened on Friday. The reconstruction of the bridge was begun in May of last year by the Leith Dock Commission. The contract for the mason work was given to Mr. John Bert, contractor, and the tender for the steel work and hydraulic machinery was placed in the hands of Sir W. G. Armstrong and Company, Newcastle. The total cost has been about £8,000. The length of the structure is 100ft., and the width 37ft. The former drawbridge was 26ft. wide. On the bridge a double line of tramway rails has been laid down in Bernard-street and Commercial-street. On each side of the bridge there is a foot-path 7½ft. wide. The bridge is carried on a central cast-iron pivot with steel socket fixed in the massive framework. The structure consists of four steel girders, with two side girders of lattice work, which form the parapets. The bridge weighs 340 tons, and is swung by hydraulic rams. The steel work and hydraulic machinery were erected to the design and under the direction of Mr. Peter Whyte, superintendent of the harbour and docks.

**VAUXHALL BRIDGE.**—A design for the new bridge over the Thames at Vauxhall has been approved by the London County Council. Sir Alexander R. Binnie, engineer to the Council, has prepared the design, which embodies the principle of a granite bridge backed with concrete. The structure will have the appearance of a granite bridge, and the design permits of it being erected like Waterloo or London Bridge. The bridge will have five arches, supported by four piers and suitable abutments. The central span will be 149ft. 9in., two intermediate spans 144ft. 6½in., and the two land spans 130ft. 6½in. each in width. The structure will be 760ft. in

length, and only 28ft. in height above Trinity high-water mark. In order to break up the long line of parapet, the engineer has introduced columns, which will ultimately carry the lamps for the illumination of the roadway and the river. The Parliamentary estimate for the cost is £380,000.

### OBITS.

A freehold ground-rent of £200 per annum, secured on No. 79, Lombard-street, with reversion to the rack-rent in 36 years, was sold at the Mart on Tuesday for £12,200, or exactly 61 years' purchase.

Mr. John Whitton, formerly engineer-in-chief of the New South Wales State Railway, has just died in Sydney. Mr. Whitton was born at Wakefield, in Yorkshire, in 1819. After many years' experience on the English railways, he was appointed in March, 1856, on the recommendation of the President of the Board of trade, engineer-in-chief of the New South Wales Railways, and had sole charge of the construction of railways and also of railway surveys in the colony. For many years he was also in charge of the locomotive and permanent way branches. Mr. Whitton retired in 1890.

The urban district council of Newton-in-Makerfield have resolved to establish waterworks for the district in accordance with a report by Mr. Richard Brierley, C.E. The scheme has been reported upon favourably by Mr. D. Gaskin, of Nottingham, and Mr. Hill, water engineer to the Manchester Corporation.

The extensive sawmills and timber-yard of Messrs. Christopher Brown and Co., at West Hartlepool, were destroyed by a fire on Friday. The damage is estimated at £10,000. Many men are thrown out of work.

The sales at the Auction Mart last week, as registered at the Estate Exchange, produced the considerable aggregate of £189,853, in comparison to £94,787 for the corresponding week of last year. The properties on offer were very numerous, but, with few exceptions, not very important in character, and the demand fully kept pace with the increased supply, good prices being maintained throughout.

On Sunday the Bishop of Worcester consecrated the new transepts and nave of St. Margaret's Church, Olton, together with a pulpit, and pews in the north and south aisles, which have been given by two friends of the church. St. Margaret's was opened two years ago, but only proper seating accommodation has hitherto been provided in the nave, chairs having been used in the north and south aisles. These have now been replaced by pews corresponding with those in the nave. The new pulpit is of open traceried work and panels, with a central figure of St. Margaret. The work is by Mr. Bridgman, of Lichfield. The steps leading to the pulpit are of marble. The chancel screen, which is of alabaster, is 3ft. high.

The Duke of Norfolk will lay the foundation-stone of a new public hall and club premises in connection with St. George's Cathedral in Westminster Bridge-road, on Saturday, March 19.

At West Ham on Monday Mr. G. E. Hilleary held an inquest as to the death of William M. Whittell, 48, a builder, lately residing at 22, Idmiston-road, Forest Gate. It was proved that deceased fell from his bicycle in a fit, and, being unable to give his name and address, by the advice of a medical man was conveyed to the West Ham Hospital. The post-mortem examination revealed that death was due to extensive cerebral hemorrhage, caused by extreme muscular exertion. The jury returned a verdict in accordance with the medical evidence.

The Duchess of Cleveland, who some time since presented a stained-glass window to the parish church of St. Mary, Battle, in memory of the late Duke of Cleveland, has now supplemented the gift by the erection of a reredos.

The Guard-street schools for the Workington School Board are being warmed and ventilated by means of Shorland's patent Manchester grates, the same being supplied by Messrs. E. H. Shorland and Brother, of Manchester.

The board of guardians for the Stockport Union met on Monday to consider the proposed erection of a workhouse. There was considerable discussion over a suggestion to divide the contract into two and to let the work to different contractors. Ultimately it was proposed to accept a tender of £138,476 for the whole of the works. An amendment postponing any further action until after the election of a new Board was, however, carried by 17 votes to 15.

The sanitary committee of the Manchester Corporation have reported in favour of an extension of the Monsall Fever Hospital, at an estimated cost of £27,000. It is proposed to construct additional wards—including an isolation ward and an erysipelas ward—with new administrative buildings.

### PARLIAMENTARY NOTES.

**THE NATIONAL COLLECTIONS.**—Sir C. Dilke asked the Chancellor of the Exchequer on Friday whether he had further considered the expediency of a Civil Works Loans Bill for spreading over several years the cost of such works as those connected with the rehousing of portions of the National Collections. The Chancellor of the Exchequer: Yes, sir, I have considered this matter. A Bill has been prepared, and will shortly be introduced.

**THE WALLACE COLLECTION.**—Mr. Akers-Douglas, in answer to Lord Balcarres on Friday, said: The Trustees of the Wallace Collection have proposed extensive alterations and additions to Hertford House, in order to render it suitable for exhibition purposes. These alterations and additions will be carried out by the Office of Works, and have already been commenced. There is no probability of their being completed and the collection arranged for exhibition at least for 18 months from the present time.

**CONDITION OF WESTMINSTER HALL.**—**CHEMISTS' ADVICE MORE VALUABLE THAN THAT OF ANY AMOUNT OF ARCHITECTS.**—Earl Stanhope asked, on Friday, whether, in view of the decay or depreciation of the stone on the south side of the new wall of Westminster Hall, they would take early steps to repair or to silicate the same. He said that on the south-western side of Westminster Hall the new stone had turned a white colour, and decay was rapidly going on. He suggested that a Departmental Committee consisting of a few architects should inspect the wall and see what steps could be taken.—The Earl of Pembroke said that he was informed by the First Commissioner of Works that the wall on the west side of the interior of Westminster Hall had been, since it was refaced by the late Mr. Pearson, the subject of much consideration and concern to the Office of Works, owing to the decay that set in on certain portions immediately after the completion of the work. Two kinds of stone were used in the alteration, Ketton and Anstone, and it was almost entirely in respect to the former that the decay had taken place. Every effort had been made to discover the cause of the decay, even to a minute analysis of both the stone and mortar used in the wall, but without any light being thrown on the subject, and an induring process recommended by the late Mr. J. L. Pearson, R.A., which was applied in 1896, had not been successful. The failure was the more remarkable because the same stone used on the exterior showed no signs of decay. The matter was receiving every attention, and steps would be taken to apply any process which might give reasonable promise of success. He would represent the suggestion as to the Departmental Committee to the First Commissioner; but it appeared to him to be a chemical rather than an architectural question, and, therefore, any committee who might be appointed should not necessarily be composed of architects, but rather of persons with a knowledge of the chemical process that went on in stones, whose advice would probably be more valuable than that of any amount of architects.

### STAINED GLASS.

**OLD WHITTINGTON CHURCH, CHESTERFIELD.**—This week men have been engaged fixing a stained glass window of three lights and tracery, the subject in the centre light being that of the Crucifixion, and the sinister and dexter lights respectively Nathaniel under the Fig Tree and Christ's Charge to St. Peter, whilst the large tracery is represented with Our Lord in Majesty and Angels with Censers. The details are of an elaborate character. The window is from the studio of Messrs. Swaine, Bourne, and Son, King Edward's-road, Birmingham, under the supervision of Messrs. Rollinson and Son, architects.

The Wakefield and district master builders have decided to form an association. Mr. J. Bagnall, of Eastmoor, has been elected president, and Messrs. E. A. Elvey, of Belle Vue, and H. Fallas, of Horbury, vice-presidents.

Colonel the Marquis of Breadalbane, K.G., opened on Friday a new Volunteer drill hall at Blairgowrie for C Company 5th Volunteer Battalion Royal Highlanders. The building is situated in Union-street, and comprises a drill-hall 60ft. by 40ft., armoury rooms for officers and men, lavatories, &c. The plans were by Mr. Robert Reid, Blairgowrie, and the total cost was £850.

A special meeting of the Bath Board of Guardians was held on Friday to consider a scheme for altering and reconstructing the workhouse on Odd Down so as to meet the requirements of the local government board. The scheme for building a separate and new infirmary at an estimated cost of £40,000 having been disapproved, the scheme now discussed was drawn up by the architect, Mr. Oliver, the cost being estimated at £30,000. It was decided to consult the local government board before coming to a decision as to the plans.

**TO CORRESPONDENTS.**

[We do not hold ourselves responsible for the opinions of our correspondents. All communications should be drawn up as briefly as possible, as there are many claimants upon the space allotted to correspondents.]

It is particularly requested that all drawings and all communications respecting illustrations or literary matter should be addressed to the EDITOR of the BUILDING NEWS, 332, Strand, W.C., and not to members of the staff by name. Delay is not unfrequently otherwise caused. All drawings and other communications are sent at contributors' risks, and the Editor will not undertake to pay for, or be liable for, unsought contributions.

Cheques and Post-office Orders to be made payable to THE STRAND NEWSPAPER COMPANY, LIMITED.

**TERMS OF SUBSCRIPTION.**

One Pound per annum (post free) to any part of the United Kingdom; for Canada, Nova Scotia, and the United States, £1 6s. 0d. (or 6dols. 30c. gold). To France or Belgium, £1 6s. 0d. (or 3fr. 30c.). To India, £1 6s. 0d. To any of the Australian Colonies or New Zealand, to the Cape, the West Indies, or Natal, £1 6s. 0d.

**ADVERTISEMENT CHARGES.**

The charge for Competition and Contract Advertisements, Public Companies, and all official advertisements is 1s. per line of Eight words, the first line counting as two, the minimum charge being 5s. for four lines.

The charge for Auctions, Land Sales, and Miscellaneous and Trade Advertisements (except Situation advertisements) is 6d. per line of Eight words (the first line counting as two), the minimum charge being 4s. 6d. for 40 words. Special terms for series of more than six insertions can be ascertained on application to the Publisher.

Front-page Advertisements 2s. per line, and Paragraph Advertisements 1s. per line. No Front-page or Paragraph Advertisement inserted for less than 5s.

Advertisements for the current week must reach the office not later than 3 p.m. on Thursday. Front-page Advertisements and alterations in serial advertisements must reach the office by Tuesday morning to secure insertion.

**SITUATIONS.**

The charge for advertisements for "Situations Vacant" or "Situations Wanted" is ONE SHILLING for TWENTY-FOUR WORDS, and Sixpence for every eight words after. All Situation Advertisements must be prepaid.

**NOTICE.**

Bound copies of Vol. LXXII. are now ready, and should be ordered early (price Twelve Shillings each), as only a limited number are done up. A few bound volumes of Vols. XXXIX., XL., XLI., XLII., XLIII., XLIV., XLV., XLVI., XLVII., XLVIII., XLIX., L., LI., LII., LIII., LIV., LV., LVI., LVII., LVIII., LIX., LX., LXI., LXII., LXIII., LXIV., LXV., LXVI., LXVII., LXVIII., LXIX., LXX., LXXI., LXXII. may still be had, price Twelve Shillings; all the other bound volumes are out of print. Most of the back numbers of former volumes are, however, to be had singly. Subscribers requiring any back numbers to complete volume just ended should order at once, as many of them soon run out of print.

RECEIVED.—F. N.—S. F. B.—D. T. W.—L. H. and Son. N. S. G.—E. D. S.—A. B. (Liverpool).

W. J. B. (We cannot undertake to give legal opinions as between landlord and tenant; but we think you are bound to pay the rent. You may have a claim against the landlord for damages, and we should advise you to consult a solicitor thereon.)—G. J. S. (The company came to grief, and its promoter has since been bankrupt—not under the most creditable circumstances.)

**Correspondence.**

**THE ROYAL GOLD MEDAL AT THE INSTITUTE.**

To the Editor of the BUILDING NEWS.

SIR,—The well-reasoned letter of "An Art Worker," which appears in your last issue, does, so far as my main contention is concerned, agree with the general principle which I expressed at No. 9, Conduit-street. I was roused to speak, not because I had any doubts as to the eligibility of our President, but because the nomination came from the Council, with a decided colouring of the "snuggery" (as "An Art Worker" puts it), against which I have protested again and again during the last few years.

I may, or may not, agree with the names which "An Art Worker" puts forth as worthy of the Royal Gold Medal; but of one thing I am certain, and that is, that there are gentlemen whom I can name who have thoroughly well earned the honour which the bestowal of the medal confers, and who have done excellent and laudable service in the direction of that "promotion of architecture," which, according to the Charter of the Institute, constitutes the ground for the grant of the medal.

For example, Did the late Wyatt Papworth do nothing for the promotion of architecture? Has Arthur Cates done nothing to entitle him to the honour? Are his labours on the "Dictionary

of Architecture," his work in connection with the Institute examinations, and the fact that during his reign as Crown Surveyor he has secured the very best architectural results on the Crown Estate, to be allowed to pass unnoticed? Has Professor Robert Kerr done nothing towards the elevation of the literature of our profession, nothing in his executed works, nothing by the refinement of his intellect, which must have made in years gone by (it did upon mine) such an impression upon the attendants at the meetings at No. 9, Conduit-street, to bring him within the Charter scope of "promotion of architecture"?

And other names could easily be suggested the owners of which are thoroughly entitled to the honour. But, as I said at the Institute, it becomes really impossible to suggest any name at all, because the "snuggery," by its action, places a distinct obstacle in the way—the obstacle being that if one presses forward a candidate, however worthy, it is at the cost of fighting one's own President. The want of tact, the want of mere common-sense, the want of consideration for the privileges of the general body of members, are indelibly impressed upon the action of the Council. They, and they alone, are responsible for placing our President in the position in which he is placed. They have permitted to arise a little blot upon what should, and would a little later on, have been a clear and fair shield; and if I were the President, I should say, "Save me from my friends!" The Council have proceeded in this matter exactly as they have done in many other instances: they think and act as if the whole corporate body were mere subscribers of so many guineas a year, and had no voice whatever in the affairs of the Institute; they arrogate to themselves any outside attraction which they can secure; they comfort themselves with all the attributes of a mutual admiration society; they send forth opinions and plans as the work of "The Royal Institute of British Architects," of which that Royal Institute is absolutely and entirely ignorant, and upon which it is completely uninformed; they endeavour to suppress from the Journal all that may expose their shortcomings; and, finally, they seek to gather into their own undivided and precious hands the bestowal of the Royal Gold Medal, that signal honour the bestowal of which the Charter confers upon the corporate body.

It is against this line of conduct which I have persistently and consistently protested, and against which I shall, on every proper occasion, continue to protest; and I am happy to find that, although "An Art Worker" does not "approve of my methods," he at least is with me in the endeavour to prevent our prerogatives being gradually filched from us by a practically self-elected permanent council.—I am, &c.,

WM. WOODWARD.

13, Southampton-street, Strand, Feb. 23.

**CHIPS.**

The Bishop of Rochester on Saturday consecrated the new church of Holy Trinity, Roehampton, the foundation-stone of which was laid in April, 1896, by the late Duchess of Teck.

The Great Western Railway Company are about to expend about £40,000 in building a new station at Carmarthen, and a smaller amount in erecting a goods station at Tenby.

At the last meeting of the Haunts County Council, it was announced that a residence had been erected for the chaplain at the county lunatic asylum at Fareham, from plans by Messrs. Cancellor and Hill, of Winchester, Messrs. Green being the contractors. Plans and a report by the county surveyor were submitted for the extension of the asylum at a cost of £21,000 by the addition of infirmary wards containing 150 beds. This extension will raise the accommodation to 1,200 beds, its full limit of capacity. The plans were approved. It transpired that the entire cost to the county of preparing plans were £100 paid to a draughtsman, whereas if the council had consulted an outside architect the outlay would probably have been from £1,400 to £2,000.

At a general meeting of the Royal Society of Painters in Water Colours held on Friday evening, Messrs. Louis Davies and James Paterson were elected Associates.

The Lowestoft Town Council have decided to place 40 groynes upon their south beach from the south pier to the borough boundary, at a cost of £1,300. The borough surveyor has been instructed to prepare plans for a concrete sea-wall to protect the Denes. A Horsfall refuse destructor has been determined upon, the cost of which will be £3,000.

**Intercommunication.**

**QUESTIONS.**

[11903.]—**Specifications.**—What is the exact meaning in the following extract from specification for painting new plastered walls? "The walls shall be cleaned down, prepared, sized, and painted three coats of lead paint in approved tints." What I want to know is the word "preparing" to be taken as meaning a coat of oil and driers, or is such coat to be taken as meaning the first coat of the three coats of lead paint as specified? If the latter, then the word "preparing," as applied to new work, is a misnomer, because all that is required to be done in new work is cleaning down after ceiling whitening, and then the oil and drier coat to receive paint.—PERPLEXED STUDENT.

[11904.]—**Wind Pressure on Bridge Girders.**—Can anyone inform me how wind pressure is allowed for on the main girders of a plate-girder bridge, and should any allowance be made for vertical pressure? The outline cross-section of bridge would be like this:—



I have been unable, so far, to find any reference to this in books on bridge construction.—C. E.

[11905.]—**Balloon Framing, Plastering, &c.**—I shall be glad of information on the subject of balloon framing as practised by the Americans, and if any correspondent can recommend a cheap book on the subject I shall be obliged. I shall also be glad to know how Portland cement plastering is done on lathwork. Owing to the brittleness of the mortar, plasterers tell me they cannot work it satisfactorily on laths. Masons also object to using Portland-cement mortar for walling for the same reason. I am told that one part of cement to six of sand, with one part of foundry loam added to make it work fat, makes a very strong mortar. The foundry loam in country districts is, however, difficult to get. Would putting lime answer as well as the loam for toughening purposes while working? I am aware that the lime would weaken the mortar; but so would the loam. Will blue lias lime gauged with Portland cement make a satisfactory plaster for outside work? If so, in what proportion should the lime, cement, and sand be used; and should hair be incorporated with the mortar? An answer will be much appreciated.—EXCALIBUR.

[11906.]—**House Drainage.**—How can a detached villa, nearly square in block, be drained? The soil-pipe and bath-waste come down at the back, and the scullery sink is on the right-hand side, not far from corner. Is it necessary to have an inspection chamber where these drains meet, besides one in front of house next the road along which the sewer runs? It seems necessary to run the main house drain down the right-hand side of house between these two chambers, and to make separate branches into it for rain-water pipes. Am I right here? Then is it necessary to ventilate the manholes, or which one—probably the interceptor? Are there any good patterns of gully traps for stackpipes in stoneware or iron? Will be glad of information.—DOMUS.

[11907.]—**Jointing Drain-Pipes.**—I should be glad to hear the opinions of practical correspondents as to the most desirable joint for drain-pipes (stoneware). Some recommend neat cement, others cement and sand in certain proportions; others prefer the Stanford patent joint. Which has been found to answer the best in ground that is clayey, or that is apt to settle? Is there much difference in cost?—SIGMA.

[11908.]—**Plastering Hospital Wards.**—Is there any plaster or cement specially used for this purpose? Is Keen's or Parian cement a good covering for walls where hardness and non-porosity and cleanliness are necessary? A tiled dado is often provided. An opinion from a specialist will be valued.—A. L.

**REPLIES.**

[11887.]—**Load on Girder.**—Let A B represent the girder resting on the rolled joist at C. Consider A B as a

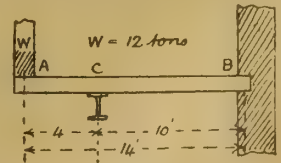

lever whose fulcrum is B, loaded with weight W at the end A. Let x = the pressure on rolled joist at C. Then, taking moments about fulcrum B, we have—

$$x \times CB = W \times AB.$$

$$\text{or—} \quad 10x = 14 \times 12.$$

$$\text{Therefore—} \quad x = \frac{14 \times 12}{10} = 16.8 \text{ tons.}$$

Hence the pressure at C is 16.8 tons.—H. BUSBRIDGE.

[11900.]—**Waterproofing Rough-Cast.**—A rubble wall rough-cast is very exposed to be attacked by driving rain. Its very roughness favours the lodgment of water. "H. C. S." recommends saturating the wall with several applications of hot boiled oil, or linseed oil, in which glue has been dissolved. Boiled oil will do good, and the gelatine solution, and the tallow soap in boiling water are useful as preventives of dampness, by closing the pores of the plaster. Szerelmeij's solutions and the "Fluate" supplied by the Bath stone firms are also found to prevent the percolation of moisture, and "Enquirer" might try them. They both waterproof the stone or plaster. If these fail, I should recommend the wall to be battened inside.—A BUILDER.

## LEGAL INTELLIGENCE.

**CLAIM BY AN ARCHITECT.**—At a special sitting of Chester County Court, last week, his Honour Sir Horatio Lloyd was engaged for several hours in hearing an action brought by Daniel J. Kennedy, surveyor and architect, Liverpool, to recover £31 10s. from John Bird, landlord of the Fielding Arms Hotel, Pantasaph, for professional services and expenses incurred. Plaintiff's case was that while he was engaged doing some work in the neighbourhood of Holywell Convent for Mr. Kirby, architect, Liverpool, he was introduced to defendant, and subsequently he prepared plans for the erection of nine cottages and a shop at Holywell for defendant. The plans were passed by the urban district council; but at the last moment defendant was not able to raise the mortgage money, and accordingly was not able to carry the work out, so plaintiff did not prepare the specifications. Finally plaintiff pressed for the payment of his bill, and defendant offered him three guineas. Plaintiff estimated that the work could be done for £1,100, and he charged commission at the rate of 2½ per cent. on that amount. Plaintiff denied that it was suggested that he should do the work for defendant in a friendly manner. Evidence in support of plaintiff's case was given by Mr. Whalley, architect, Chester, and Mr. Owen, architect, Liverpool. For the defendant it was contended that this was an arrangement based on friendship. Plaintiff went down and stayed occasionally with defendant, who did not charge him anything, and Mr. Bird being anxious to help plaintiff in his business, introduced him to Mr. Montgomery, a brewer. There was no understanding as to payment for the plans, and defendant did not adopt them because he was informed by a builder that if the buildings were erected according to them they would cost something like £2,000 instead of £1,000. It was further claimed that plaintiff was not entitled to commission in a speculative transaction of this kind, and that £6 paid into court by defendant was all plaintiff was entitled to. His Honour pointed out that the £6 was not paid into court in time, nor was it paid with any proportionate costs, so that in two respects it failed. The payment of the money into court determined the verdict, except as to the amount. Defendant's counsel submitted that plaintiff's charges were excessive, and he called two Liverpool architects in support of this view. His Honour, in giving judgment, said he could quite understand that owing to the hilly nature of the site of the proposed buildings plaintiff's work was not easy. On the other hand, the parties met in a friendly kind of way, and there was a good deal of mutual obligation. With regard to the contention that the plans could not be carried out at the proposed cost, he pointed out that it was often necessary to ask architects to cut down their plans. Under all the circumstances, he should give plaintiff a verdict for ten guineas, with costs on that amount.

**LIBEL ACTION AGAINST A CITY SURVEYOR.**—**NASH v. DAVIS.**—At the Bristol Assizes, before Mr. Justice Darling and a special jury, an action was heard on Wednesday and Thursday in last week, in which Percy Alan Nash sued Charles Edward Davis, city surveyor, of Bath. The statement of claim alleged that the defendant libelled the plaintiff by the publication of a certain statement with regard to the construction of a proposed new road at Bath, from the end of Pierrepont-street to Pulteney-street. Damages were laid at £250. Defendant denied the allegation, and stated that what he did publish was in his official capacity at the request of the corporation of Bath. Plaintiff's counsel stated that the plaintiff was for a time in the employ of the defendant. In 1885 the plaintiff conceived an idea of making a new road over waste lands of the corporation, and joining Pierrepont-street, Bridge-street, and Pulteney-bridge, and this plan eventually came before the notice of the corporation. Plaintiff mentioned the plans to the defendant, who said, "That is no good; I tried it myself thirty years ago, and failed to carry it." A few days afterwards Mr. Nash met Mr. William Lewis, and showed him the plans, which Mr. Lewis showed to Alderman Jolly. They were eventually deposited at the town clerk's office. After a time the plaintiff heard that these plans had been submitted to the corporate property committee by the defendant as being copies of plans prepared by himself. These plans were afterwards dealt with in a report which the defendant, as architect for the city of Bath, had prepared, and which was printed and fixed in the Guildhall. It was in this report that the libel complained of was published, as follows:—"In 1895, in consequence of a letter from the town clerk, Mr. Hunter called at my office. He asked my clerk, Mr. Nash, to show him the plan of the road. In my absence, Mr. Nash made search in Pulteney-street for the plan, and again the same day, accompanied by a pupil, but unsuccessfully. I found the plans of the roads 'not in their accustomed place.' Shortly after this Mr. Nash informed me that he had been making a plan for a new road from Pierrepont-street to New Market-row, which Mr. Moger, clerk to the urban sanitary authority, and father-in-law to Mr. Nash,

thought excellent. On his describing it to me I recognised it as the same as my own. I told him so, and I thought my so expressing myself was sufficient, and from his being in my employ, in possession of knowledge that otherwise would not have been the case, I consider that in this matter he has not been loyal to me. Mr. Nash has been in my constant employ something like ten years, exclusive of a short time when he started for himself, but, on his solicitation to return, I again availed myself of his services." Counsel thought the charge of disloyalty was a very grave charge to a professional man. The plain inuendo was that the plaintiff took advantage of his position, surreptitiously copied plans, and put them before the council as his own. Anything more injurious than this to a man in his client's position he could hardly imagine. Percy Alan Nash, the plaintiff, corroborated this opening statement. Cross-examined: He never saw an entry in the defendant's index box relating to drawings for the Orange Grove-road. In the summer of 1895 Major Davis left his old office in Pulteney-street, which remained unoccupied, except for the old papers which remained in the pigeon-holes. He took a Mr. Clarke there to look for some plans of the house. Mr. Clarke never asked to see the plans of the new road. His lordship remarked that it was somewhat odd that due north was at the upper part of the original plans, but not on the Ordnance maps, though the same peculiarity was observed in the new plans prepared by plaintiff. Plaintiff, in reply to Dr. Blake Odgers, stated that after Major Davis had expressed disapproval of what witness had done, he had his plans lithographed, and sent copies to members of the town council. He did not consider he was competing against his employer in what he did. It would have been wrong to have so competed with his employer in this matter. Evidence of publication of the alleged libel was given. For the defendant it was argued that there was no evidence of malice disclosed. Defendant's clerk had done something improper, and, when called upon to make this report, Major Davis had been bound to refer to it. He was not responsible for what the members of the town council might think fit to do. They ordered this report to be printed at the expense of the corporation. The occasion for the publication was privileged. Mr. Cyril Thompson, an architect and surveyor in private practice in Bristol, said he was formerly a pupil of the defendant at Bath. Plaintiff was there at the time. At the request of defendant he made an index of the plans at the offices in Pulteney-street, including a roll of plans relating to a proposed new road from Pulteney-street to Pierrepont-street. Major Davis, city architect and town surveyor of Bath, said he was appointed to the office in 1863. Before 1865 a new street was projected from Pierrepont-street, and the matter had frequently been discussed since, fresh plans being prepared from time to time. From 1884 to 1895 the matter went to sleep. When first told by plaintiff that he had prepared a scheme for this proposed road, he expressed annoyance and said it was part and parcel of a scheme he had been trying to get adopted for the last 30 years. Later on witness laid before the council his original plans, whereupon one of the members produced plaintiff's lithographed plan, and said it was a copy. He never had any malice against plaintiff, and he never showed his reports to anyone outside the town council. Cross-examined: The words complained of in his report did not mean that plaintiff had tampered with the plans of witness, but he suggested that they were competitive. He was engaged at a nominal salary, with commission. He considered that the corporation were bound to employ him upon all their works, but they did not think the same. The Judge, in summing-up, said he had already held that defendant had a right to write the words complained of, because he was acting under the cover of privilege. If the jury believed Major Davis was instructed by the town clerk or his assistant to get this report printed, where was there any malice? They must also remember the time defendant kept plaintiff in his employ after he had prepared his scheme, when they were considering the question of malice. He should put before the jury four questions:—(1) Was the publication of defendant's MS., including the report—which contained the words complained of—in consequence of instructions to that effect given by the corporation? (2) Did the defendant instruct the printer to print his MS. in consequence of directions given to that effect by the corporation? (3) Was defendant actuated by malice in writing or in publishing the words complained of? (4) Was plaintiff not loyal to defendant? The jury answered the first two questions in the affirmative, the third in the negative, and, with regard to the last, they said plaintiff was not loyal. A verdict entered for defendant accordingly.

**IN RE T. W. LACEY, OF ROCHESTER.**—A receiving order was made against Thomas William Lacey, described as a surveyor, by the Rochester County Court on December 3 last. The proceedings have since been transferred to the High Court, and recently a sitting for the public examination was held before Mr. Registrar Brougham, sitting at

the London Bankruptcy Court. The accounts showed liabilities £2,780, of which £330 are unsecured, with an estimated surplus in assets of £749. It appeared that the debtor has failed on four previous occasions, and he ascribed his present position to a judgment having been obtained against him in respect of a disputed claim for building materials alleged to have been supplied under his guarantee. Upon the case being called, the Registrar remarked that an application for adjudication was recently adjourned to enable the debtor to pay the debts in full. Applications were also pending for orders of discharge under the previous failures, and under the circumstances it might be more convenient if the present sitting was adjourned. This course was adopted, and the case was adjourned until March 25 next.

**ALLEGED BREACH OF CONTRACT.**—On Wednesday and Thursday in last week, Mr. Justice Bruce and a special jury were occupied with an action for breach of contract against the Era Spinning Company of Rochdale. The plaintiffs were Messrs. Astin and Barker, of Todmorden, who obtained the contract for the supply of cast ironwork to be used in the defendants' new mill in Woodbine-street, Rochdale, and they claimed damages on the ground that the Era Company subsequently broke the agreement and gave the unfinished work to another firm. The case for the defence was that the contract was rescinded by mutual consent. There was a great conflict of evidence, but during the hearing of this case for the defence the jury stopped the proceedings and gave a verdict for the Era Company.

## CHIPS.

A site for public baths has been purchased at Frome by a local committee, who have instructed Mr. P. Edinger, the town surveyor, to prepare plans for a swimming bath 75ft. by 30ft., at a cost not exceeding £1,500, with the addition of four slipper baths.

The will and codicil of Mr. Frederick Dale Banister, J.P., of Stonehouse, Forest-row, Sussex, the chief resident engineer of the London, Brighton, and South Coast Railway, who died on December 22nd, have been proved, the value of the personal estate being £16,169 2s. 11d. gross and £12,219 6s. 5d. net.

In the application for discharge from bankruptcy in the case of Thomas French, Overbury-street, Clapton Park, N., builder, the discharge has been suspended for three weeks, ending February 10, 1898.

Mr. Arthur Cross is presenting a new organ to St. Michael's, Chester-square, at a cost of £2,000. He has entrusted the construction to Mr. Hope Jones. He is also about to build and endow a convalescent home, entirely for the use of the poor of St. Michael's parish.

The death took place suddenly on Tuesday week of Mr. David Roberts, of Transcend House, Llandudno, in his 76th year. The deceased, who was a retired builder and contractor, went to Llandudno over 50 years ago, when the place was but an obscure village. He was among the first builders to erect lodging-houses at the "Queen of Welsh Watering-places," and had been a member of the old board of the town improvement commissioners. He was a poet and hymn-writer, being known in Welsh bardic circles as "Boreuafard."

The presentation to the Art Gallery Committee of the Manchester Corporation of a reproduction in bronze of Mr. John Cassidy's terminal bust of Mr. Henry Clarence Whaite, R.W.S., president of the Manchester Academy of Fine Arts, took place at the Art Gallery, Mosley-street, in that city, on Tuesday week.

The dissolution of partnership is announced of W. Kidner and W. H. Atkins Berry, architects and surveyors, Old Broad-street, E.C., under the style of Kidner and Berry. Also the partnership hitherto subsisting between G. Bywaters, A. Bywaters, W. D. Bywaters, F. S. Bywaters, and A. J. Bywaters, builders, King-street, Regent-street, W., under the style of G. H. and A. Bywaters and Sons, so far as regards G. Bywaters and A. Bywaters has been dissolved.

The trustees of the Birmingham Churches Fund have appointed Sir Arthur W. Blomfield, A.R.A., to act as their assessor, and decided to invite a number of architects to compete for the erection of a new church in the parish of Sparkbrook in the place of Christ Church, Birmingham.

The oldest Wesleyan Methodist Chapel in Manchester is shortly to be vacated and afterwards demolished by the Great Northern Railway Company. It is the Great Bridgewater Street chapel, which was erected in 1800.

At Friday's meeting of the Conway and Colwyn Water Board, it was reported that the result of the arbitration between the contractor (Mr. Bugbird) and the board on a claim of £638 had been in favour of the former for £482. The award settles everything between the board and the contractor.

## Our Office Table.

M. PAUL PERDRIZET, the well-known French archæologist, gave at the Passmore Edwards Settlement, on Tuesday, an address on the recent excavations by his countrymen at Delphi. Sir John Evans presided. M. Pedrizet, who gave his address in French, made the tour of the precincts, starting from the Treasury of the Athenians and ending with the Stadium. He dwelt on the interest of the ancient precinct of Gaia, the Earth Goddess, the primitive mistress of the oracle displaced by Apollo. The rock of the Sibyl, the traditional seat of the first priestess, was shown, and M. Pedrizet hazarded the conjecture that the unfileted *omphalos* found in the Treasury of the Athenians was the original altar of Gaia herself. The mutilated metopes of the Athenian Treasury were also exhibited. The Temple of Apollo was discussed, and the lecturer made clear how again and again it had suffered destruction from earthquakes. The temple, of which the foundation has been laid bare by the French, is of the 4th century B.C., but built into its foundations at the west end are portions of the earlier temple of the Alkmaonidæ; fragments, too, of the sculptures of this earlier temple remain in the mass of *débris* heaped up when the ground was cleared for the new structure. Below the foundations of the west portion of the temple are traceable the rocks that once formed the prophetic chasm noted by Aristotle as within the temple. While the French excavations were in process Delphi was visited by an earthquake. At the close of the lecture Dr. A. S. Murray, who had visited the site himself, moved a vote of thanks; the excavations at Delphi, he said, in point of scientific importance, stood second to none.

MR. JAS. PATON, Curator of the Glasgow Corporation Art Galleries, delivered on Monday night in those galleries the tenth of his addresses on the Italian painters, his subject on this occasion being Tintoretto and Paolo Veronese. After dealing with the early life and training of Tintoretto, the lecturer said there was never a man more wedded to his art or disinterested in its prosecution. He would paint for the price of his materials or for nothing rather than not paint at all; and such was his unworldliness that in his later days he had to be guarded by his family against unscrupulous visitors. He worked with an incredible impetuosity of temperament and boldness of will. He conceived his figures on the grand lines of Michael Angelo; his fertility of invention was inexhaustible; his imagination was as comprehensive as it was active and untiring. His own restless activity and energy are reflected in the tumultuous and sometimes melodramatic action of the crowded figures in his picture. In his earlier works, mythological as well as religious, he is somewhat timid and restrained; but he gives full rein to his fiery imagination and boundless energy in his series of pictures, "The Miracles of St. Mark," which have been designated as among the most gorgeous pages in the history of art. In his mature works he revolutionises and gives an air of modernity to the traditional subjects with such boldness of invention, with such vivacity of movement and gesture, with such fertility of combination in grouping and decoration, such passionate warmth in the execution, and occasionally with such pathetic grandeur in the expression, that in the presence of such mastery surprise even exceeds admiration.

THE annual report of the National Footpath Preservation Society states that three more corporations have joined the society, with two district councils and four parish councils. Receipts from members have amounted to £233 6s., and the total income to £288. The expenses for the past year amounted to £259 12s., and the balance carried over was, therefore, £23 8s. The footpath cases during the year were not quite so numerous as in the previous year, the number being 271, against 290. The past year is stated to have been most disastrous as to law proceedings respecting rights of way. The first important matter was the Winter Hill case, near Bolton. It occupied the Court at Bolton seven days in March last, and judgment was given against the right of way by Vice-Chancellor Hall. The next matter took place in Dublin almost at the same time—the Giant's Causeway case. This also occupied seven days, and judgment was given by Vice-Chancellor Chatterton in Dublin

against the right of way on April 29 last. An appeal has been heard. The next case was an alleged right of way near Spennymore in Durham; the judgment in this matter was also adverse to the claim of the public. An appeal was heard, but unfortunately failed. The fourth case was that of Paddock Wood, Surrey: the jury could not agree, and the verdict of the majority was taken against the right of way.

THE properties exposed for sale in Glasgow during 1897 amounted in value to £924,413; while those of 1896 were £771,880—an increase for 1897 of £152,533. In the city of Glasgow and the suburbs the statistics show that property was exposed at £2,127,668, and there was realised £716,458, being a gain on the upset price of £33,925. In 1897 feu-duties of the annual value of £944 exceeded at the upset price of £29,900 fetched £30,600—an increase of £700, showing that something between 31½ and 31¾ years' purchase was asked; while the price actually realised figures out at fully 32½ years' purchase. In 1896 the upset price began at the average of 30½ and finished a fraction over 31½ years' purchase, proving that 1897 commenced higher than the previous year's highest, and finished nearly a year's purchase higher. The annual value of ground annuals exposed last year was £1,076, at the cumulo amount of £33,632, or a little over 31¼ years' purchase. These fetched £35,040, or a little over 32½. The gross rental of Glasgow for 1897-98 is:—Dwelling-houses, £2,030,334; other subjects (including railways and canals), £2,501,845 total, £4,532,179; empty dwelling-houses, £46,903; other untenanted subjects, £75,478—total, £122,381. This is an increase in the rental as compared with the preceding year of £99,603, and a decrease in the empty property of £22,451.

A SERIES of experiments on the strength of timber is being carried out on a large scale for the United States Government by Dr. B. E. Fernow, of the Forestry Division of their Department of Agriculture. To examine and test a sufficient number of specimens of any given species is a costly undertaking; but the department has preferred to expend its appropriations in doing thorough work on a limited number of species rather than in doing more or less superficial work upon a larger variety. During the past year Dr. Fernow rented a testing machine with which to carry on his investigations. In the course of his work he made the important discovery that a constant mathematical relation exists between the compressive and the tensile tests of any species of timber, and that henceforth it will be sufficient to make a laboratory compressive test, the tensile strength being calculable from the data so obtained. Dr. Fernow gives the credit for this important discovery to Mr. S. F. Neely, one of his assistants.

The coast tram service between Lytham and Blackpool, a distance of nine miles, was commenced on Monday, and the line is to be extended to Fleetwood, eleven miles further on. The system of traction employed is gas, which, although known on the Continent, is now for the first time being tried in England.

Two stained-glass windows were placed in St. Oswald Church, Thirsk, on Friday, to the memory of the late vicar, the Rev. L. G. Maine, M.A., and Mrs. Lambert, the founder of the local hospital.

A memorial window to the late Mr. James Sharrocks, Newbold, is to be erected in the chancel of St. Peter's Church, Rochdale. The subject is "The Good Samaritan." The work has been intrusted to Messrs. Comere and Capronnier, of Brussels.

The church of St. Mary the Virgin, Aldermanbury, E.C., is about to be entirely redecorated from the designs of Mr. Lewis E. G. Collins, A.R.I.B.A., of 31, Great St. Helen's, E.C.

The directors of the Bath Stone Firms, Limited, have decided to recommend a dividend for the six months ending Dec. 31, 1897, at the rate of 11 per cent. per annum, making, with the interim dividend paid in September, 9½ per cent. for the year. The annual meeting will be held on March 11, and the transfer books will be closed from the 26th inst. to March 11, both inclusive.

Mr. T. G. Taylor, borough surveyor of Douglas, Isle-of-Man, has been appointed borough surveyor of Ramsgate out of 120 applicants. Mr. Taylor went to Douglas from Leicester about nine years ago, and during his term of office has carried out many important works. His salary at Douglas was £200 a year, and his commencing salary at Ramsgate is £350, rising to £400 in two years.

## MEETINGS FOR THE ENSUING WEEK.

MONDAY.—Society of Arts. "The Principles of Design in Form." Cantor Lecture No. 3, by Hugh Stannus. 8 p.m.  
Carpenters' Hall Free Lectures. "Some Notable Buildings in France," by Prof. T. Roger Smith, F.R.I.B.A. 8 p.m.  
TUESDAY.—Institution of Civil Engineers. Discussion on "Alternate-Current Motors" and on "The Dublin Electric Tramway."  
WEDNESDAY.—Society of Arts. "Kites: their Theory and Practice," by Captain B. F. S. Baden-Powell. 8 p.m.  
Edinburgh Architectural Society. "Combined System of Steam-Heating and Cooking and Domestic Hot-Water Supply," by A. Hunter Crawford. 8 p.m.  
FRIDAY.—Birmingham Architectural Association. Lecture by Professor G. Aitchison, R.A., F.R.I.B.A. 6.45 p.m.

## CHIPS.

It has been decided that the memorial, at Horn-castle, to the late Mr. Edward Stanhope, shall take the form of an obelisk with granite base, to stand in the Market-place at Horn-castle.

The parish church of St. Mary, Tadcaster, was reopened on Saturday, after undergoing repairs and extensions which have been carried out at a cost of £1,300.

Colonel Jeremy-Taylor Marsh, R.E., an inspector under the Local Government Board, held an inquiry at the Council Chamber, Leeds Town-hall, yesterday, into an application by the City Corporation for powers to compulsorily acquire certain properties, under the Lands Clauses Act, for purposes of street improvements. To the principal proposal of the corporation, that for a new street from Briggate to Vicar-lane, considerable opposition was offered.

A new church to be dedicated to St. Martin is to be built in Edinburgh from plans by Mr. Robertson, of Inverness, at a cost of £5,000.

On Saturday night the Dublin Master Builders' Association held their annual dinner at Jury's Hotel in that city. The company numbered about ninety. The Right Hon. J. M. Meade, LL.D., president of the association, occupied the chair, and responded to the toast of the evening, which was proposed by the High Sheriff of Dublin, Alderman Pile. The toast of "The Architects" was proposed from the chair, and acknowledged by Messrs. W. M. Mitchell, W. Kaye Parry, and R. C. Orpen.

A movement is on foot for building a public hall for Liverpool. The site is near Emmanuel Church, West Derby-road, and it is proposed to erect a hall to accommodate 6,000 persons, besides room for another 1,000 on the stage. The style will be Lombardic, and the building materials red brick and terracotta. Under the stage will be a niche or hall to seat 700 persons, and the entire cost of halls and shops is estimated at £60,000. Mr. W. Parslow, of Duke-street, Liverpool, is the architect to the promoters.

Mr. Henry Yates Thompson has arranged to provide for Stanley-park, Liverpool, a palm-house somewhat similar to one he placed in Sefton-park in the same city in 1896. The Sefton-park palm-house and its plants cost over £12,000; that for Stanley-park will be about 120ft. long, and will cost about £6,000. Mr. Thompson waited upon the parks and gardens committee of the corporation on Wednesday with Mr. Mackenzie, of the firm of Mackenzie and Moncury, horticultural builders, Edinburgh, who submitted the plans of the structure which the firm will build. Mr. Thompson was warmly thanked by the committee.

A proposal to extend the Walker Art Gallery at Liverpool is now occupying the attention of the corporate committee controlling that institution. In order that the pictures in the permanent collection may be hung to the best advantage, considerable additional space is required.

At the last meeting of the urban district council for Littleborough, Lancs., the clerk read a letter from Messrs. Clark and Hutchinson, architects, John-street, Bedford Row, W.C., asking whether it is the intention of the council to proceed with the erection of the proposed new offices, fire engine station, &c., this spring. Messrs. Clark and Hutchinson won the premium which the council offered several years ago for the best plan for these buildings, and they have written several times, at long intervals, asking whether the council intend to proceed with the work. After some discussion, it was decided to reply that the council do not at present propose to commence the buildings.

A new Wesleyan chapel, erected in Dearne-street, Brightside, Sheffield, was opened on Thursday in last week by the President of the Conference. The building has cost about £2,255, and it provides accommodation for nearly 400 persons.

A large mansion on the Waynflete estate, Bristol, has been presented to the city by Mr. Edward P. Wills, for the Convalescent Home. The building is situated in its own grounds of three and a half acres, on the borders of Burdham Down. The grounds are well laid out, and the aspect on all sides is open and airy.

LATEST PRICES.

IRON, &c. Table with columns for item, Per ton, and Price. Includes Rolled-Iron Joists, Wrought-Iron Girder Plates, Cast-Iron Columns, etc.

Table for Gas-Tubes, Steam-Tubes, Galvanised Gas-Tubes, Galvanised Water-Tubes, Galvanised Steam-Tubes.

Table for Sheet Zinc, Sheet Lead, Pig Lead, Copper Sheets, Tin, Straits, Do., English Ingots, Spelter, Silesian.

TIMBER. Table with columns for item, per load, and Price. Includes Teak, Burmah, Bangkok, Quebec pine, Oak, Birch, Elm, Ash, Dantsic and Memel Oak, Fir, Wainscot, Riga p. log, Lath, Dantsic, p.f., St. Petersburg, Greenheart, Box, Sequoia, U.S.A., Mahogany, Cuba, per super foot.

Table for Quebec Pine, Canada Spruce, New Brunswick, Riga, St. Petersburg, Swedish, Finland, White Sea, Batters, all sorts, Flooring Boards, Staves, per standard M., U.S. ditto, Memel, cr. pipe, Memel, brack.

OILS. Table with columns for item, per ton, and Price. Includes Linseed, Rapeseed, Do., brown, Cottonseed, refined, Olive, Spanish, Seal, pale, Coconut, Cochín, Do., Ceylon, Palm, Lagos, Oleine, Lubricating U.S., Petroleum, refined, Tar, Stockholm, Do., Archangel, Turpentine, American.

Trade News.

WAGES MOVEMENTS.

CARDIFF.—The masons' strike has ended. At the Royal Hotel on Wednesday week a meeting was held of the representatives of the masters and men, and, after discussion, terms were arranged, subject to approval by the Masters' Association at their general meeting on the following night.

LEICESTER.—Some months ago the Leicester branch of the Carpenters' and Joiners' Society gave notice of a demand for an advance in wages, as well as an amendment of the rules which govern the trade.



BILLS OF QUANTITIES, PLANS, &c.

Lithographed in best style and with great expedition by PARTRIDGE & COOPER, ARCHITECTS' AND SURVEYORS' LITHOGRAPHERS, 191 & 192, Fleet St., and 1 & 2, Chancery Lane, London, E.C.

W. H. LASCELLES and Co.,

121, Bunhill Row, London, E.C. TELEPHONE No. 270.

HIGH-CLASS JOINERY. LASCELLES' CONCRETE.

Conservatories & Greenhouses. WOODEN BUILDINGS.

BANK, OFFICE, & SHOP FITTINGS. CHURCH BENCHES & PULPITS.

ESTIMATES GIVEN ON APPLICATION.

IS THE ELECTRIC LIGHT REALLY DEARER THAN GAS?

A large number of replies to the above query from actual users will be sent post free on application to the

COUNTRY HOUSE SPECIALISTS, Messrs. DRAKE & GORHAM, 65, VICTORIA STREET, WESTMINSTER, LONDON, S.W.

HAM HILL STONE. DOULTING STONE.

THE HAM HILL & DOULTING STONE CO. Incorporating THE HAM HILL STONE CO. and C. TRASK and SONS (THE DOULTING STONE CO.)

Chief Office: NORTON, STOKE-UNDER-HAM, SOMERSET. London Agent: Mr. E. A. WILLIAMS, 16, CRAVEN STREET, STRAND.

WM. OLIVER & SONS,

MAHOGANY, WAINSCOT, WALNUT, TEAK, VENEER, and FANCYWOOD MERCHANTS, 120, BUNHILL ROW, LONDON, E.C.

The most extensive Stock of every kind of Wood in Planks and Boards, dry and fit for immediate use.

TENDERS.

Correspondents would in all cases oblige by giving the addresses of the parties tendering—at any rate, of the accepted tender: it adds to the value of the information.

ALFORD, Lincs.—For erecting a granite Jubilee memorial drinking fountain:—Curtis, G. (accepted).

ASSOUAN, EGYPT.—For the construction of barrages on the Nile at Assouan and at Asuit, for the Egyptian Government. Mr. John Henry Garstin, C.S.I., of Cairo, engineer:—

Aird, J., & Co., London (accepted) about £30,000. BATTERSEA, S.W.—For the enlargement and alteration of the fire-brigade station, for the London County Council:—

BETHNAL GREEN, E.—For alterations required in the stables of the Bethnal Green Fire-Brigade Station, to admit of an additional pair of horses being kept there, for the London County Council:—

BOURNEMOUTH.—For making-up Campbell, Heath Farm, Richmond Park, and Shaftesbury roads, Bournemouth. Mr. F. W. Lacey, M.Inst.C.E., borough engineer and surveyor:—

BOURNEMOUTH.—For wrought-iron fencing and gates for Horseshoe site, Bournemouth. Mr. F. W. Lacey, M.Inst.C.E., borough engineer and surveyor:—

BOURNEMOUTH.—For making up Churchill and Westbourne Park-roads. F. W. Lacey, M.Inst.C.E., borough engineer and surveyor:—

BRISTOL.—For the erection of additions to the Pack Horse Hotel, Lawrence Hill, for the Bristol United Breweries Co., Limited. Messrs. Gingell and Bond, F.R.I.B.A., 51, Corn-street, Bristol, architects:—

BROMSGROVE.—For the erection of a wood and iron building to serve as an infectious disease hospital, for the joint authorities of Bromsgrove, Droitwich, and Redditch. Mr. Gadd, of Bromsgrove, architect:—

CAMBERWELL, S.E.—For the erection of a refreshment-house in Myatt's Fields, for the London County Council:—

COVENTRY.—For the supply of wrought-iron unclimbable fencing, to be erected in Earlsdon-road, for the city council:—

DAWSHOLM, N.B.—For the extension of the purifier at Dawsolm Gasworks:—

ENFIELD.—For erection of six houses at Little Park, Enfield. Mr. John B. Thorp, architect:—

Frinton-on-Sea, Essex.—For the erection of a school for 150 children, for the School Board. Mr. Samuel T. T. James, M.S.A., Frinton, and 10, St. Mary-axe, E.C., architect. Quantities by Messrs. Kemp, Welch, and Thomas, Bournemouth:—

Hampstead, N.W.—For enlarging the fire-brigade station at Hampstead, for the London County Council:—

HEMSLEY.—For carrying out a scheme of water for Stonegrave, for the Hemsley rural district council:—

(Continued on page XVI.)

# THE BUILDING NEWS

## AND ENGINEERING JOURNAL.

VOL. LXXIV.—No. 2252.

FRIDAY, MARCH 4, 1898.

### DISCOVERING TALENT IN ART.

IS architectural ability a thing to be proud of? Or is it merely a dead weight—something to be appended to the qualifications that go to make up successful business men, surveyors, and estate agents? If the latter, then we can quite understand the remarks of our correspondents—"An Art Worker" and Mr. Wm. Woodward—in our last issue, on the bestowal of the Gold Medal at the Institute. One cannot wonder at the secession from that body some years ago of men who were bold enough to put their creed into the form of a memorial—acknowledged leaders of design, like those named by our correspondents. These memorialists had the courage of their convictions by protesting against the mere professional cliquism which so weighs down and obscures the talent and natural taste of men who ought to be the leaders in their profession. Their names would be invidious to mention. At all events, we have our Bodleys, our Bentleys, our Norman Shaws, our Jacksons, Champneys, Aston Webbs, our Hares, Wades, Austins, and many more whose works assure us of their artistic merit, and of their thorough appreciation of the difference which separates mere professional architecture from the real thing. Although the two things are as different as they can possibly be, yet we find the Institute—aye, and other professional societies—countenancing only those who have a particular way of pushing themselves into notice and who have obtained some success without in the slightest degree exercising the control which is expected from them in the interest of the art they pretend to represent. The man who can talk the most and the fastest, or the successful city practitioner, whose hands are full of fat commissions, valuations, arbitrations, and the like, pushes his way into the front rank, and enters the charmed circle, and by so doing excludes the real men of art. But we shall be told it will always be so in a world where the means and methods of gauging men's acquirements are so imperfect. No doubt! Still, there is no reason why a body of professional men should not have some better means of discovering the real latent talent, as it may be like the hidden treasure, or obscured by circumstances. If they cannot do so, what are our examinations worth? If in spite of all talent and the hard study of these men to achieve a place in their profession, they still find Mr. Brown and Mr. Jones, who have capital, and are eager for fame, able to get on councils, and be recipients of medals, while their studies have not availed them anything, they may well turn in disgust. And if education and ability cannot effect an entrance or win a commission to men who have proved their knowledge of the rudiments of their profession, how can we expect the natural-born artist to share any better? When we see the highest distinctions are given to men of inferior talents, and for designs of very commonplace merit, as those which are exhibited in the academical schools of the profession, it is fair to inquire what guarantee we have that examinations can be conducted on any surer basis? No! it is impossible under our present conditions for promoting architecture or art that anything can be expected during a man's lifetime. After his death, then, perchance, his talent may be discovered—a satire surely on our present modes of reward.

It is hard to discover talent of the real kind,

because, forsooth, it is not looked for. Antecedents, influence, birth, the "accidents" of the individual are the points which the profession look to. We have never yet heard of a committee of inquiry to examine closely into a man's real skill as an artist, or his works as exemplifying his ability—the quality of his art. This is not the way pursued. Rather is it to find the number of his commissions, how many public buildings he has erected, or whether any of them have been opened under royal or auspicious patronage. The architect who has designed and erected a few modest buildings or houses and churches of exceptional merit, whose art is expressed in every plan and in every detail, and whose work is always above the standard of modern tastes, is not the man whose qualifications appear, because these are not the things that are looked for. Nor does the retiring and modest artist reap any benefit. His work is always admired by the few who are competent to pass judgment, but overlooked by the many who prefer the "loud," obtrusive, and bizarre. It is this side of art, as of other things, that obtains popularity. We have few that can or will appreciate the subtle, the hidden, or the refined; these qualities are not popular, and probably never will be, with the masses. So, in estimating a man's title to a reward or a distinction, the number and cost of his buildings will always be esteemed. Whether it be in cathedral restorations, the building of innumerable churches or town-halls, or national monuments, the architect who can show the biggest record is the man of the hour. For indomitable energy and business qualification he deserves the honour. We do not deny it to him; but what we should like to see is some recognition of talent, unostentatious and quiet though it be.

But if the professional bodies cannot discern it, how can we expect the public at large to do so? We cannot wonder at the frequent failure of competitions. The ordinary building committee made up of local tradesmen, or the average owner of estates who wants to build, are unable to discover the really good or honest design; they take the blatant or showy instead, and it is often a case of "casting pearls before swine" to try and open their eyes by sending in better designs than they have power to appreciate. And yet the talented designer can do nothing else than conceive what is able, and clever, and honest. It is quite impossible for him to do anything common or vulgar, and therefore he remains in quiet obscurity till someone comes along his path and discovers his talent. But even then he can design only for the few; his chances of promotion are small indeed. Now and then we come across his work—unobtrusive and sober, but always thoughtful; it may be in a small country house or village church, or piece of decoration. On the other hand, his more popular *confrère* meets with a large demand. His work is showy and "up-to-date," and probably he gets as much as he can possibly do well; but he can employ "ghosts," and depute clerks of works to carry out his buildings without any punctilios of conscience. He is in the "swim," and he does not intend to exalt his art at the cost of his brains or his pocket. Art with him is something to make a living by, not to be lived up to. His policy is undoubtedly more profitable, and he may win a title by it.

The craftsman is another individual who can hardly obtain his just recognition. Those who employ him too often disregard his skill or his artistic feeling. So long as he can turn out his work at a given rate, or by the piece, he is thought to be a profitable workman. His individual effort is neither estimated nor paid for. Men, it has been truly said, "will not do an extraordinary day's work for an ordinary day's pay," and it is absurd to expect any skill for such remuneration.

Taking our average building crafts, such as the bricklayer, carpenter, plasterer, and plumber, the reward is in no sense proportional to the quality of work; the consequence is that good workmen are not easily found. Skill in any particular craft is often too scantily recognised by employers or foremen; someone else gets the benefit of any "wrinkle" or improved method of execution, just as a large manufacturing firm often takes the credit of its designer's ability. Hundreds of such instances may be mentioned where individual talent remains concealed, and the capitalist or the plodding workman reaping the reward.

### MODEL SPECIFICATIONS. — II.

EXCAVATOR.—PRELIMINARY NOTES.

WE propose to take an ordinary building—such as a country villa or town house—and to give examples of clauses under the several trades. And we first deal with the *Excavator*. In excavating trenches for brick footings, it is customary to allow an extra width of 6in. or 8in. on each side at the bottom of trench to enable the men to work. Sometimes the bottom of trench is cut to horizontal benches or steps, to suit the fall or inclination of ground, in which case care must be taken to prevent settlement of the wall at the points where the depth changes, by using thin joints. All angles of building, if high, should be laid with large stones, and the foundations under high portions of the building should be carefully laid to prevent subsidence. Foundations in clay soil should be rather deeper than in gravel or other non-yielding soil, say, 4ft., as clay is liable to crack by heat, especially after much rain.

The architect should also consider if the soil is such in deep trenches as to require planks or poling boards at intervals kept up by struts. In loose ground it is necessary to place the poling boards close, and to support them by planks or "walings" longitudinally, these being strutted between by scantlings. Sometimes in running sands and clays the sides of the trench have to be protected by planks put lengthwise, which is then called "sheeting," this being done at a foot deep at a time; the planks are strutted across as before. (See sketches.)

The width necessary for concrete foundations will depend on the bearing resistance of the ground. A maximum load of 1½ to 2 tons per square foot is usually allowed. If the soil is able to support a load of, say, 2 tons per super. foot, and if stock brickwork in lime mortar will carry 5 tons per super. foot of section, then if we divide 5 tons by 2, we get 2½ as the ratio of width of concrete to thickness of wall. The concrete base for a square pier of brickwork may be found by calculating the weight of pier footings and concrete, and then by dividing it by the safe load on the earth, say 2. Thus, if the pier and footings weigh 50 tons,  $\frac{50}{2} = 25\text{sq.ft.}$ , and the size of square base of concrete will be 5ft.

The full width of the trenches should be filled with concrete. In soft and wet grounds a grill or platform of elm or oak, and, in some cases, of rolled iron joists, is used, on which the footings are built. The spaces are filled up with concrete, and then planked or concreted to receive the footings. In writing specification of concrete in trenches, it is necessary to define the proportions of lime, ballast, sand, and whether the concrete is to be thrown in or rammed in layers. If the depths of excavation or trenches are not shown by the sections, state them, and provide for filling up any holes, cesspools, and grubbing up old foundations.

The By-laws of the London Building Act provide that "no house or building shall be

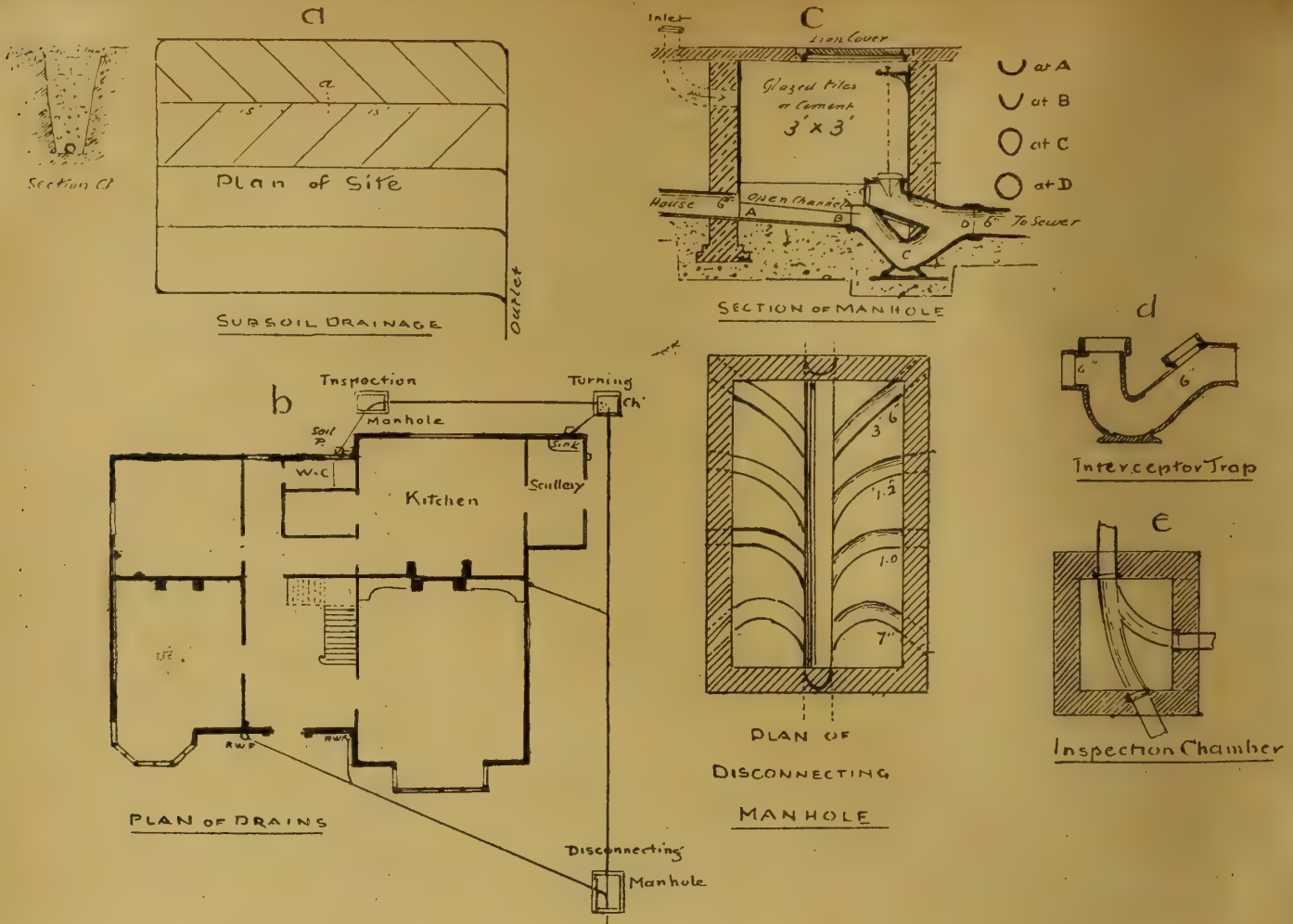

erected upon any site which shall have been filled up or covered with any material impregnated or mixed with any faecal, animal, or vegetable matter, or which shall have been filled up or covered with dust or slop or other refuse," or upon which any such matter has been deposited, "unless and until such matter or refuse shall have been properly removed by excavation or otherwise from such site" (see By-law 2, section 16, of Metropolis Man. Amendment Act, 1878). Section 31 of the General Powers Act, 1890, also provides "that any excavation made within a line drawn outside the site of a house, building, or erection, and at a uniform distance therefrom of 3ft., shall not be filled up otherwise than with the natural soil or with brick or dry rubbish or other suitable material approved by the district surveyor," &c.

The following are a few specimens of model clauses which may be selected or modified to suit particular cases :-

1. **Clear Site.**—Cart away all rubbish, and clear the site for setting out building. Or—Remove the turf carefully, and stack the same for re-use. Or—**Surface Digging.**—Dig and cart away all vegetable and surplus earth from site, and wheel and deposit same where directed. Or—Remove surface-soil to an average depth of 1ft. (or 18in.) over the whole site of building; wheel and deposit the same on terrace or where directed. (State distance to which earth is to be deposited.) Or—
2. **Excavations.**—Excavate for the buildings, areas, yards, &c., to the depths, levels, and inclinations shown, and cart away superfluous earth not required for refilling or improving levels, &c., which must be of hard, dry material. Or—Excavate for all trenches to the depths shown on the drawings, and to the following widths; for one-brick walls, 2ft. 6in.; for 14in. walls, 3ft. 6in. wide. Level, and ram the earth, &c.
3. **Basement or Cellars.**—Excavate the ground for basement to a depth of 8ft. (or 10ft.) below Datum level, and deposit the earth where directed, or within 20 yards run, and fill in hollow parts or improve levels where required.

- Old Buildings and Material.**—Shore up and make secure adjoining buildings. Take down old building, clean and stack old bricks and other materials, which the architect may approve as being fit for re-use, and remove all debris. Grub up old foundations and drains, and empty and cleanse old cesspools and wells, and fill in with hard, dry material, and well ram.
4. **Underpinning.**—Excavate the ground for underpinning old walls, and deposit earth where directed. Shore up walls and floors of adjoining buildings. Provide all necessary needles and strutting. The excavation to be made in short lengths—say, about 4ft. at a time.
  - Excavation in Loose Ground, &c.**—In loose ground timbering and shoring are required, and a clause may be introduced of this kind:—
  5. The sides of all excavations and trenches to be secured by shores, sheeting, plankings, or walings, strutted across. Provide all pumping, and keep excavations clear of water. Or in—
  6. **Quicksand.**—Pile round the area to be excavated, and dig down to solid bottom and fill up with cement concrete to level of footings. (State area and depth of excavation.)
  7. Well ram the bottom of all trenches for foundations. The contractor is to report to the architect when the excavations and trenches are ready to receive the concrete or footings, so that the architect may inspect the same, and order, if necessary, any further excavation.
  8. **Concrete in Trenches.**—The concrete to be composed of 1 part of fresh ground Dorking (Halling or Maidstone) stone lime and 5 parts of clean ballast, and 1 of sand, thrown into trenches, and will rammed in layers. Or—To be composed of freshly-burnt ground blue lias lime from Barrow (Whitby, or Aberthaw).
  9. **Portland Cement.**—The cement to be from an approved manufacturer, and weigh not less than 110lb per struck bushel, and be subjected to the usual test of sifting and crushing. The ballast to be clean pit or river, of approved size and quality, with a proportion of sharp sand. Or—The cement to be Portland, from the Thames or Medway, finely ground and weighing not less than 112lb. per bushel struck, or more than 120lb., and when shaken through a sieve of 2,500 meshes to the square inch, shall not reject more than 15 per cent, and be of the tensile strength of 350lb. per square foot after seven days' immersion.

- The cement to be laid in a dry place not more than 18in. deep some three weeks before using, and well turned over before use. Or—
10. **Cement Concrete.**—To be of Portland cement one part to 7 parts of Thames ballast and broken brick or stone. Or—One part of blue lias stone lime, one part of sand, and six parts of ballast, broken stone or brick. Or—Cement concrete to be composed of 5 parts of ballast, 2 of sand, and 1 of Portland cement, measured in boxes, mixed dry, turned over three or four times, then water added and turned over again until the whole is incorporated. (Other proportions are sometimes used: these will depend on the nature of the foundations. For those under water, 1 of cement to 4 or 6 of gravel and sand.) One writer gives the following:—
  11. **Method of Mixing and Laying Concrete.**—The specified proportions to be mixed on a clean wood floor after careful measurement, and the materials turned over three times in a dry state, and then wetted through a coarse watering rose whilst being turned back the fourth time, and finally turned over once more and immediately deposited on the trenches in layers not exceeding 12in. in depth. Each layer to be well rammed and the top surface swept clean, picked over, and sprinkled with water before another layer is deposited. Each layer is to be allowed to set separately.
  12. **Concrete on Underpinning.**—The underpinning of walls to be done in short lengths at a time, with hot Portland cement (or grey chalk lime) concrete.
  13. **Concrete Under Floors, &c.**—Lay a bed of concrete, as above, 6in. thick under all wood floors; also for all tile and cement pavements.
- The L.C.C. By-law 2 provides that the foundations of the walls of every building shall be formed of a bed of good concrete not less than 9in. thick, and projecting at least 4in. on each side of the lowest course of footings. On a gravel site this provision is not enforced. "The concrete is to be composed of clean gravel, broken hard brick, properly burnt ballast, or other hard material to be approved by the district surveyor, well mixed with freshly-burned lime or cement in the proportions of 1 of lime to 6,



and 1 of cement to 8 of the other material." It is also provided that the site of every building shall be covered with a layer of good concrete, at least 6in. thick, and smoothed on the surface.

14. *Subsoil Drainage*.—Trench out ground according to subjoined plan, and lay dry 3in. (or 2in.) diameter earthenware subsoil drains, in 12in. lengths, in parallel lines 15ft. apart; also the lines between them (herring-bone), which diverge in the direction of fall. The depth of trenches (which are regulated by the kind of soil) is to be 3ft. deep, cut as shown, and to a fall, or to follow the inclination of ground. These drains are to discharge into the lower of the surrounding drains inclosing site, or into any natural stream or outfall sewer. A suitable trap to be provided, and a ventilating opening made near it.

(According to a by-law of the Local Government Board, such drain-pipes are not to communicate directly with any sewer or cesspool; but a suitable trap, with ventilating opening as near as possible to trap, is to be provided.)

15. Fill in the trenches over the pipes to a depth of 15in. with fine porous earth; above this the ordinary earth is to be shot on lightly, and afterwards rammed.

If it is necessary to prevent vermin and mice getting into the pipes, insert "Cover all outlets with wire netting or broken glass."

If the drains come under the walls of the building, which should be avoided if possible, we may add to the clause:—Lay the pipes in concrete arched over the drain with openings at intervals for drainage. The clause for subsoil drainage may run thus:—

Trench out the site or ground, and lay where shown on site plan A, 3in. (or 4in.) earthenware agricultural drain-pipes—say 3ft. deep (the depth varying from 2ft. 6in. for tenacious clay, to 4ft. 6in. in depth in loose, gravelly sand) every 15ft. apart, as shown herringbone-wise to the outer drain. The inclosing or outer line of drains to be of 9in. socketed pipes and junctions, and to discharge into ditch or sewer with wire netting or an iron grid.

In our next article we shall deal with house drainage—both with reference to country and suburban and town buildings.

#### THE ARCHITECTURAL ASSOCIATION.

THE fortnightly meeting of the Architectural Association was held at 9, Conduit-street, W., on Friday evening, the president, Mr. Hampden W. Pratt, F.R.I.B.A., occupying the chair. Messrs. E. G. G. Box and C. Gilbertson were elected as members. A number of donations to the library were reported by Mr. E. HOWLEY SIM, hon. secretary, and were acknowledged with thanks. On the motion of Mr. G. B. CARVILL, hon. sec., a vote of thanks was accorded to Mr. Sidney R. J. Smith, for allowing members to visit, on the previous Saturday, the houses in course of erection from his designs in Park-lane, W. The PRESIDENT announced that the discussion section would hold a meeting on March 9 (Wednesday in next week), when Mr. J. J. Waldram, of the Institute of Junior Engineers, and Mr. Sydney B. Beale would open a debate on the subject of "The Desirability of a Closer Relationship between the Engineer and the Architect."

#### LEAD WORK: PLAIN AND DECORATIVE.

A lecture on this topic, illustrated by examples and many practical demonstrations of tinning, casting, &c., was delivered by Mr. F. W. TROUP, A.R.I.B.A. The author introduced the subject by a quotation from a paper by the late William Burges, A.R.A., published so long ago as December, 1856, in the *Ecclesiologist*, in which that gifted artist and architect discovered the use made of ornamental lead-work by Mediæval architects in France. He also translated some passages from "The Principles of Architecture," by Felibien, published in Paris in 1690, as giving a succinct description of all the crafts as then practised. Passing on to the practical side of the subject, Mr. Troup pointed out the superiority in wear of

#### CAST OVER MILLED LEAD,

especially when used for roofs over old oak work. They were told, he remarked, by the advocates of cast sheet-lead that it turned to a silvery grey or white in course of time, whereas milled lead

always turned black on the surface. Certainly the beautiful patina on the surface of many old roofs of cast sheet-lead went in support of the first part of the theory; but he thought it wanted some further investigation and proof to show that cast sheet-lead under modern conditions—which, of course, included the metal as well as the atmospheric conditions—would also oxidise to a silver grey or white patina. The roofs of St. Paul's Cathedral and the buildings attached to it were, and always have been, covered with cast lead. From these roofs they might therefore be able to judge conclusively, as there was a constant repairing being carried out in which freshly cast lead was used. But he gathered from Mr. F. C. Penrose and his plumber some years ago, that the stock of old lead was adhered to and simply recast, and in the stock the lecturer distinctly remembered seeing piled up in the crypts fragments of very old lead waterpipes, and even several examples of Roman pipes. In this connection Mr. G. E. Crickmay, of Weymouth, recently found, when restoring Nethbury Church, Dorset, that a cast-lead roof which had been on for a hundred years, was perfectly sound; but that a portion of the roof which was covered with 7lb. milled-lead only 24 years ago, was eaten full of holes, owing to oxidation from the oak underneath. As soon, however, as one came to ornamental lead-work there was no longer any question as to whether cast or milled lead was best. With the latter one was confined to bossing, whereas in casting a sheet it was not only possible, but very easy, to imprint patterns or letters or ornament in the sand bed, and it was still possible to boss or beat up the cast sheet to what extent one pleased after the casting was complete. Turning and engraving could be done equally well on either kind of lead; but in the cast sheet all work, however wrought, gained by the superior texture of the ground surface. There was, again, a great difference in the metals themselves—between old and modern lead. The chief difference consisted in the greater purity of modern lead. Silver was frequently found in conjunction with lead ores, and formerly this was but partially extracted. By modern perfected methods it was profitable to extract the silver if the lead contained only a few ounces to the ton. Whether this absence of silver in modern pure lead had any effect upon the colour to which the surface oxidised or "weathered," as some have held, he was unable to say; but he thought there was no question that the

#### OLD LEAD WAS HARDER

and more self-supporting in exposed positions, from its slight admixture of silver and traces of other metals (tin, iron, copper, and sometimes antimony and manganese), alloys being nearly always harder than the principal metal in the composition. In this connection it was interesting to note Burges's remarks upon window leads (from the paper referred to already):—"Now, the lead for this purpose was cast, not milled; it was also much narrower than the modern, but contained, if anything, more metal. The consequences are that much of it is good up to the present time, while our flat, broad-milled window lead having its grain broken by the milling, and presenting a very thin and very broad surface to the air, becomes rapidly deteriorated. At Beauvais I saw some lead, which was probably put up at the end of last century, quite in a state of oxidation, and at Tournay, where the whole immense windows of the choir have been filled with stained glass, at no very distant period a very large expense will have to be undergone to fresh lead the whole, as nothing better than the common cottage window lead has been employed." Let them note that thin lead soon oxidised and absolutely perished altogether. This might seem strange when they remembered how everlasting lead sometimes seemed to be. The reason was very simple, and should not be overlooked. A fresh, clean surface of lead tarnished very rapidly when exposed to the atmosphere, owing to the formation of a thin, closely-adhering film of oxide. This film protected the metal from further change, excepting that itself in course of many years became (in the case of cast lead) a fine patina of appreciable thickness. Where the lead itself was of considerable thickness, the loss of strength from this oxidation of the surface was inappreciable, but when the lead was rolled out so thin that the film of oxidised metal bore a considerable proportion to the whole thickness of the metal, it was no longer able to serve its purpose, and tore or dropped away as strain or wear and

tear came upon it. Mr. Troup continued: Now a word as to the

#### LAYING AND WORKING OF LEAD.

Whether milled or cast, it matters not; there is room for much improvement on modern methods. You have only to look at the exhibits sent in by the students of the Polytechnic schools for the prizes to see that the ideal aimed at is all wrong. The results are often wonderful and extremely praiseworthy if only they were of any use. But the working of the lead as at present taught seems to me to be labour misapplied. What practical value is to be had from a three-branched soil-pipe beaten out of one single sheet of milled lead? The dexterity and patience required to do such work is astounding; but it serves no practical purpose. Mechanical precision in lead-work is not only wrong from its being labour misapplied; but it renders the life of the metal shorter, its cost greater, often prohibitive, and certainly does no good to the woodwork it covers. Plumbers with their 5lb. or 6lb. milled lead nowadays often beat and dress the lead over the wood like a coat of paint. The result is that frequently the lead cannot expand and contract freely, as it ought, to prevent tearing and buckling; and the wood under—well, the closer you cover wood the more chance of dry-rot, and if there is any acid remaining in the wood, the more certain is it to attack the under side of the lead. What I should like to see would be a closer following after old methods, which are invariably simpler and more straightforward. My friend Mr. Dodds used to say, he admired the old gutters which seemed to be laid by cutting out a piece of lead the right shape and walking over it once or twice on your stocking soles. That was all. Nothing more is wanted. The young plumber of the present day is taught to dress and fit the sheet hard down into every angle and beat it close over the drip. For all result you get the lead, as often as not, hard fixed at each end, and under a hot sun it must buckle, under a frosty sky it must tear. At each drip the water is drawn up by suction or capillary attraction between the two sheets of lead, and if there be any snow in the gutter, as like as not the water gets up to the woodwork. By the old method all this is left loose and easily fitting, one sheet sliding over the other whether in expansion or contraction. There is no possibility of capillary attraction taking place at the drips or elsewhere, for the lead goes gently rounding over the drip, leaving a clear space between it and the turn-up of the underneath sheet. Nor can I see any special merit in beating things up out of a single sheet of lead when the same object can be attained more directly, more simply, and more rapidly by the help of

#### SOLDER.

There are limits to everything, and soldering in plumber-work may be overdone; but soldering seems to me to be the legitimate treatment for lead. The joining of two pieces of lead together by soldering is as pre-eminently suitable to the material as welding is for wrought iron, or brazing for copper. Such problems as to beat up a rain-water head from one sheet of milled lead ought not to be set, except as a subject for students' practice—a kind of study in lead-working; and even then it is dangerous, as likely to result in a mere display of manual dexterity and skill, and to develop into such methods of laying and dressing lead as I have described and condemned already. Having referred to the tinning and decoration of lead, the lecturer said, in conclusion: I would recommend those who wish to study the possibilities of the plumber's art historically to avail themselves of Mr. Lethaby's excellent little work, where they will find a most interesting chronicle of the best work to be found in this country in all periods, besides invaluable suggestions and guidance for the worker in lead. I have referred very slightly to ancient examples, although it would be easy to discourse for hours on the multitude of beautiful examples of coffins, fonts, cisterns, pipes and pipe-heads, spires, roofs, ridges, finials, &c., which remain all over this country and abroad. These form an attractive array for any student, and as every town has its examples, at any rate of the later developments of the plumber's art, an interesting study might be made of the varying types in different localities. This, however, is not my object, and I would rather warn you against "cribbing" or reproducing old examples. What I wish to show you is the simplicity of the old methods of work, by what simple ways (almost child's play) they

attained their ends. And, again, from the very ease with which ornament can be applied or wrought on this lead you must not imagine that you have reached the goal when you have covered your material with beautiful ornament.

LEARN THE POSSIBILITIES OF YOUR MATERIAL.

before you attempt to design in it. You architects cannot possibly study thoroughly all the materials you have to deal with; but it is always possible to study one or two, and the doing so will let in a flood of light upon all the others. This knowledge will make you very modest, indeed, in attempting to design with blacklead, white paper, and a T-square. You have only to try once by designing first on paper, and then attempting yourself to carry out that design in actuality to learn what a poisonous and deadly thing it is for a craftsman to have to follow line for line "the architect's design." All freedom is gone; what would have been a quaint twist, or an amusing play of colour or shade, is sacrificed and killed in order to follow absolutely the black and white skeleton on paper. You have only to try it once in any material you like to find the truth of what I say. When once you have learned something about your material, paper-and-pencil is very useful; but you will use it in a more tentative way, knowing that many things occur to render a slight change a necessity in order to get the best result from what you have in hand; the drawing is but a means to an end.

A vote of thanks to the lecturer was proposed by Mr. W. H. SETH-SMITH, and seconded by Mr. MATT GARBUTT, and having been supported by Mr. H. LONGDEN, Mr. ARTHUR BOLTON, and the PRESIDENT, was carried by acclamation.

Mr. TROUP briefly replied.

ELECTRIC LIGHTING NOTES FOR ARCHITECTS.—XVIII.

By AN ASSOC. INST. ELECT. ENGS.

MEASURING INSTRUMENTS AND TESTING.

THE determination of the electrical quantities, ampère and voltage, should be easily and readily made in every electric-light installation; in fact, electrical measurements are as important commercially as the weighing of goods, or the measure of water flowing through a pipe. And as these measurements have to be made so constantly, the instruments used should indicate the strength of the current in ampères, and the pressure in volts, directly, without having to refer to tables, or to make calculations before we can obtain these quantities. When it is remembered that electricity itself cannot be seen and treated as a material substance, it will be obvious that the methods employed in making electrical measurements will be totally different from the ordinary methods of making measurements, as for instance, in measuring lengths, &c. We are, in fact, compelled to take advantage of the effects which are produced, and accompany the passage of electricity through conductors to indicate the existence of currents of electricity, and it is by means of these effects that we are able to measure and compare them. It is well known that currents of electricity possess (1) magnetic, (2) thermal, and (3) chemical properties; or, in other words, that currents of electricity:

1. Set up magnetic fields, magnetise pieces of iron and steel, and deflect compass needles.
2. Raise the temperature of the conductor through which they pass; and
3. Decompose compound liquids, and bring from them their constituent elements.

The magnitude of these effects depends upon the strength of the current producing them, and it may be shown that by each of these effects we can determine the strength of the current, and also that the results obtained by the different methods are concordant. In only one case, however, is the effect directly proportional to the current; and, even in that case (the decomposition of liquids by electricity), the method is not applicable for everyday work, because the result is obtained indirectly. To determine the current, we must first determine the amount of decomposition by weighing, and then calculate the strength of the current. It is, however, the method to be adopted in the calibration and standardisation of instruments for measuring currents. In the case of the heating effect, the amount of heat produced by sending a current through a wire is proportional to the square of the current; whilst

the magnetic effect is equally dependent upon a constant, and is not directly proportional to the current. In spite of this, however, the magnetic property is the one used almost universally in measuring instruments, and the following notes are intended to give some idea of the principles employed. The instruments that we shall deal with are ammeters for measuring currents in

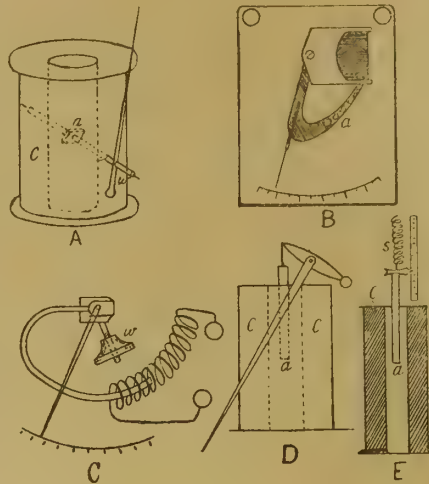

FIG. 61.

ampères, *voltmeters* for measuring electrical pressures in volts, *wattmeters* for measuring electrical power in watts, and *ohmmeters* for measuring resistances in ohms directly. The mechanism of these instruments consists of fixed and movable parts, and the readings are given by means of a light aluminium index-finger or pointer moving over a scale. The movements of this pointer, indicating ampères, volts, watts, or ohms, as the case may be, depend upon the movements of an exploring needle, rod of iron, or coil of wire forming the movable part, and it is evident that in all cases the position taken up by such movable part is that of the resultant of two forces—i.e. (1) a controlling force, tending to keep the pointer in the zero position, and (2) a deflecting force, tending to move it from the zero position. There are many ways of producing and arranging these forces, and as most of the instruments in use belong to that class of instrument known as electro-magnetic, the deflecting force is the magnetic field set up by a current passing through a coil or solenoid of wire, forming the fixed part of the instrument. This magnetic field acts either directly on the movable part, or by magnetising pieces of iron placed so as to repel or attract the movable part. And here it may be remarked that the magnetic field inside a solenoid is most uniform and strongest at the centre of the axis of the coil, whilst nearer to the ends the lines of force diverge from the axis, and the field increases in strength as we approach the sides of the coil from the axis. It is thus

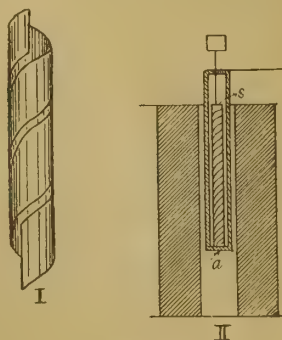

FIG. 62.

evident that a piece of soft iron of the same length as the coil (assumed to be short) has its poles at the ends when a current traverses the coil, and consequently it will take up its position on one side (the strongest part of the field), if free to move; a short piece of soft iron, however, tends to take up its position at the centre and along the axis when a current traverses the coil, if placed at the centre of the coil.

The controlling force, which should be of constant intensity, may be due to permanent or electro-magnets, the force of gravity as by weights, springs, or the tension of a wire; and, as might be expected, many ingenious attempts have been made to dispose the controlling and deflecting forces so as to produce a satisfactory working instrument. The working parts of these instruments are usually inclosed in a circular metal case fastened on to a slate or polished wooden base, to which are also fastened the terminals of the instrument. The usual type is of the clock character, a dial being fixed to the front, over which the index-finger moves across a divided scale marked Ampères, Volts, Watts, or Ohms, as the case may be. In front of the dial and pointer a glass face is fixed to protect the instrument from dust and dirt, and the finger from draughts.

The essential feature of these instruments is that they are *direct-reading*; consequently the measurements will not be so exact as if very delicate galvanometers were used. Galvanometers, however, are only suitable for the measurement of the small currents, and would be out of place altogether for the measurement of the large currents used in electric light and power circuits. They, moreover, are neither direct-reading nor portable; and ammeters are universally used for the measurement of current strength, and the requirements of a good instrument are:—

- (1) They should be direct-reading, (2) simple in construction, (3) sensitive, (4) the scale should start at zero and read right up to the limit, (5) the scale should be fairly open, (6) they should not be affected by neighbouring currents or

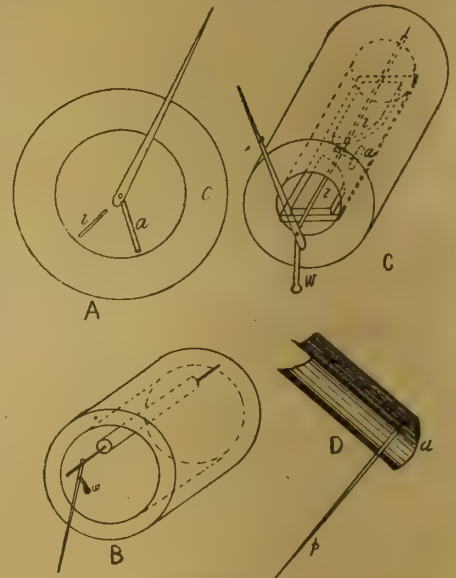

FIG. 63.

magnetic fields, nor by changes of temperature, (7) they should be dead-beat, (8) they should indicate the direction of the current—especially if used on accumulator or arc-light circuits, (9) they should be capable of being fixed vertically or horizontally, and also of withstanding the rolling of ships if used on ships, and (10) they should be cheap. It is also essential that they should not waste energy, or cause a loss of pressure, and since ammeters are traversed by the full current, the coils consist of a few turns of thick wire, so that the resistance is usually very small. Voltmeters, on the other hand, are placed as shunts to the main circuit, and so carry little current, being wound with a large number of turns of fine wire. This is practically the only difference between ammeters and voltmeters of the electro-magnetic type, so that it will only be necessary to deal with main principles.

*Ammeters.*—The instruments which we shall consider have been chosen and arranged according to the principles they illustrate, rather than from commercial considerations.

The type shown in Fig. 61 consist of solenoids which act on soft iron cores, and the piece of soft iron, being placed in a magnetic field not uniform, is drawn from the weaker to the stronger part of the field.

In this class of instrument the core is magnetised by the magnetic field; but the strength of the temporary magnet is not proportional to

the current, since it depends upon the permeability of the iron, which varies considerably with different field strengths. The readings are therefore not directly proportional to the current, the action being proportional to the product of the strength of the field and the strength of the temporary magnet. In each of the figures, *a* is the soft iron core, *b* the arbor, and *c* the coil.

In Fig. 61, *A* represents Miller's patent, the controlling force being the force of gravity, a small weight *w* being used for this purpose. *B* represents a very simple form of gravity ammeter made by the Société des Téléphones de Zurich, in which the core is a peculiarly horseshoe-shaped piece of thin soft sheet iron, the tongue of which is drawn more or less within the coil according to the strength of the current. This tongue is pierced at intervals with holes as shown, by means of which the sensibility of the instrument may be adjusted. The pointer is attached to this core, and the weight of the core and pointer forms the controlling force. *C* represents a similar instrument introduced by Edison, *w* being a counterweight of such a weight, and so placed as to keep the pointer at zero when the instrument is not in use; *D* is another gravity instrument, and illustrates the principle of the instruments introduced by Lord Kelvin and Dolivo Dobrowsky. *E* represent Kohlrausch's instrument, in which a spiral spring, *S*, forms the controlling force.

Another interesting instrument of the same class, embodying several unique principles, is shown in Fig. 62. It shows the working parts of an ammeter devised by Ayrton and Perry in 1883, in which the movement of a soft iron core—which is a hollow tube—is opposed by a spring, as in Kohlrausch's instrument. "This spring, shown enlarged in Fig. 62r, is made of hard phosphor-bronze, and shaped like a narrow shaving coiled up into a cylinder of smaller diameter, and, unlike an ordinary spiral spring, it has the peculiarity that for a small increase in length along the axis, there is a large rotation of one end of the spring relatively to the other, the angle of rotation being directly proportional to the axial extension, and to the force which is applied to produce this extension." And since this spring is capable of magnifying a linear motion, it is called a magnifying spring, and the instrument a magnifying spring ammeter. The spring is placed inside the thin tube of charcoal iron, and is attached to a brass cap fastened to the tube at its lower end, and as this cap terminates in a brass pin, supported and guided at the bottom of the instrument, the tube cannot rotate at the bottom. The tube, however, is free to rotate at the upper end, to which the pointer is attached, and with even a small amount of suction

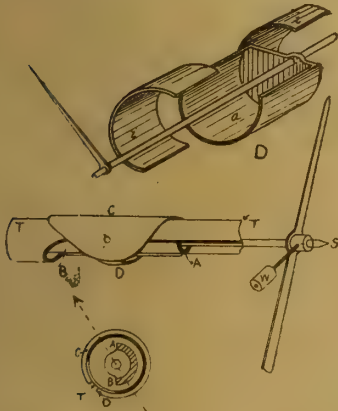

Fig. 64.

(due to a current in the coil) there is a small extension of the spring, and this produces a definite amount of rotation of the tube at the top.

This special form of core was introduced because a thin tube of iron soon becomes magnetised to saturation even in a weak magnetic field, so that when used as the core of an ammeter, as explained, it practically becomes a temporary magnet of constant strength, and the force with which it is sucked into the coil is, for all fields above a certain strength, proportional to the strength of the field, and consequently is proportional to the strength of the current producing the field. The tube is placed with about two-thirds of its length in the coil.

In another form of instrument the magnetic field inside the coil due to a current passing through the coil is modified by the presence of a fixed piece of soft iron. In Edelmann's instruments (see Fig. 63 A) a strip of soft iron, *i*, is fixed near to one side of the coil, whilst the movable core *a* (shown edgewise) is pivoted at

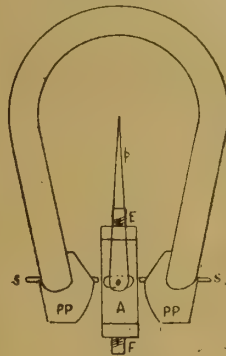

Fig. 65.

one end in the axis of the coil, and is also attached to an index-finger, as shown. The magnetic field due to the current magnetises both strips the same way, and a repellent action is thus set up, with the result that *a* is repelled. In the instrument shown in Fig. 63 B the strip of soft iron *i* is not used, the core *a* being fixed eccentrically within the coil, with its axis parallel to the axis of the coil in such a way that with the assistance of a weight the needle points to zero when the instrument is not in use. When the current passes, the core tends to move into the stronger part of the field (close to the side of the coil), and so moves the index-finger. In the earlier Evershed's instruments (see Fig. 63, C), two small soft iron slabs, *i*, are placed end to end and fixed upon a stout strip of brass, one end of which carries a brass disc which supports the arbor. The two pieces of soft iron are shaped as shown, and are placed so that there is just sufficient room for the movable soft iron core *a* (of short length and fixed to a spindle) to swing freely between them. It is obvious that the field is here intense when a current passes, so that the core *a* tends to move from a weaker field into the stronger, and so moves the index-finger. By shaping the slabs (*i*) on one side the field is stronger on that side than on the other. When not in use the core *a* takes up a position above and outside the gap between the slabs, by means of a counterweight. In Schuckert's instruments (see Fig. 63, D) a light, steel axle, *d*, is pivoted so as to lie parallel to, but a little to the left of, the axis of the coil. This axle carries a curved piece of soft iron, *i*, the same length as the coil, and at one end a light aluminium pointer, *p*. The core *i* is weighted by means of a piece of wire, *w*, which may be adjusted so that when the instrument is not in use the pointer stands at zero. When a current passes through the coil the core is drawn into the stronger part of the field (towards the side of the coil), and the pointer is deflected. The moving parts of this instrument are extremely light, and weigh not more than 300z., so that there is very little friction.

It will be well here to refer to a class of instruments which depend upon the tendency of every magnetic circuit to become as short and perfect as possible. This is rendered possible by placing the movable core of soft iron so that it tends to move, so as to close the magnetic system set up by the current. The improved Evershed's instruments (see Fig. 64) are of this type. Within a fixed brass tube, *TT* (part of which is cut away, as shown, so as to diminish the production of eddy currents when the instrument is used for measuring alternating currents) is pivoted a horizontal brass spindle, *S*, around which (but inside the tube *TT*) is attached concentrically the soft-iron core *AB*, forming a half-cylinder. On the outside of the brass tube is slipped, so as to fit it tightly, a peculiarly-shaped soft-iron collar or sleeve, *CD*, as shown in the figures. When a current circulates through the coil, the core *AB* is drawn round magnetically against the controlling force of gravity set up by the weight *W*. It is obvious that the shape of the sleeve gives more or less free magnetism on one side, and it is to this part that the core is attracted. A similar action is utilised in Hart-

mann and Braun's instruments, the working parts of which are shown in Fig. 64 D.

Many of the earlier instruments made use of permanent magnets to form the controlling force, and it is obvious that in such cases the needle could consist of a small permanent magnet or magnetic needle or a small piece of soft iron. The deflecting force, as in the examples already considered, was due to the magnetic field set up by a current passing through a coil. The needle was pivoted, and attached to it a pointer to indicate the movements of the needle. Many such instruments have been made, but we need only consider the one presented in Fig. 65, which shows Ayrton and Perry's permanent magnet ammeter. In this case the needle is a small piece of soft iron shaped like a flat ellipsoid, and it is placed between the poles of a permanent magnet. The coils of wire are wound on the two halves of a flat brass tube, *A*, so that the magnetic field set up by the current is at right angles to the field between the pole-pieces. Consequently, when a current traverses the coils the needle takes up a position coinciding with the resultant of the two fields, and the pointer is deflected. Many interesting additions have been made to the original instrument so as to improve the sensibility of the instrument and the controlling force. Pole-pieces of soft iron and of various shapes were added, as shown at *PP* in the figure; in addition to which two soft iron cores (*F* in the figure) were screwed into the ends of the brass tube (on which the coils were wound), so that the deflecting force could be varied by screwing these cores in more or less as required. Later still soft iron screws, *SS*, were added to the pole-pieces *P*, so that their ends form the magnetic tips of the pole-pieces, the distance between which could be varied at will. This type of instrument possesses the advantage of indicating the direction of the current.

No account of measuring instruments would be complete without some reference to Weston's instruments, which have been much used in America, and are now being introduced into this country on account of their sensitiveness and reliability. The working parts of one of these instruments is shown in Fig. 66, from which it will be noticed that strong permanent magnets *m*, carrying two enlarged pole-pieces, embrace a coil of wire *c*, wound on a light aluminium former, and delicately pivoted upon jewel bearings. Inside the coil of wire there is fixed a soft iron core, *p*. When a current passes it tends to turn the coil as in a motor, so that the coil may inclose as many lines of force as possible. This tendency to turn is opposed by a graduated counterforce consisting of two flat spiral hair-springs, *q*, *q*, which also serve to lead the electricity in and out of the coil, these springs being fastened at the top and bottom to the coil. We may add that the

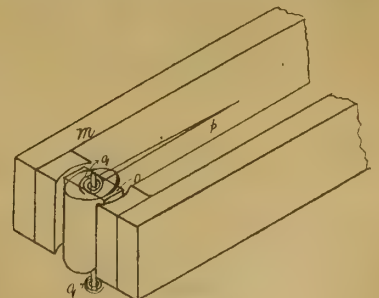

Fig. 66.

gap between the pole-pieces and iron cylindrical core in one instrument is .04in., the radial thickness of the coil, including the aluminium frame, is .015in., leaving a clearance of .0125in. on each side. These instruments are very dead-beat.

(To be continued.)

CEMENT ADMIXTURES.

FOR the past three years investigations into this matter have been made by the Cement Trade Section of the London Chamber of Commerce. They instructed Messrs. Stanger and Blount, of Broadway, Westminster, to make extensive experiments with mixtures of Kentish ragstone and Portland cement, and also obtained valuable evidence from Mr. D. B. Butler, Mr. Gilbert Redgrave, Mr. H. K. Bamber, and

Dr. Michaelis, of Berlin, and others. After full consideration the section adopted the following resolution: "That Portland Cement be defined as a mixture of two or more suitable materials intimately and artificially mixed in the requisite proportions, and afterwards properly calcined and ground, to which nothing has been added during or after calcination, excepting that an addition not exceeding 2 per cent. of gypsum is permissible for the purpose of regulating the setting. That the following rule be adopted:—

"That if any material whatever excepting 2 per cent. of gypsum for the purpose of regulating the setting be added to the Portland cement clinker during or after calcination, the article so produced shall not be sold as Portland cement, but under another distinctive name.

"That the members of the Cement Trade Section of the London Chamber of Commerce, together with all manufacturers of Portland cement in Great Britain and Ireland who are not members of that Association, be invited to sign the following declaration of conformity to the above rule in respect to all Portland cement made by them whatever. We, the undersigned, hereby agree to conform and carry out the rule of the Cement Trade Section of the London Chamber of Commerce as set forth in a report made by the Section and adopted at a meeting held on Monday, the 10th of May, 1897:—

"That if any material whatever excepting an amount not exceeding 2 per cent. of gypsum for the purpose of regulating the setting be added to the Portland cement clinker during or after calcination, the article so produced shall not be sold as Portland cement, but under some other distinctive name.

"And we further agree that if at any time any of the parties to this agreement shall by resolution of a majority of those present at a meeting of such parties duly and properly convened in accordance with the practice of the London Chamber of Commerce, such resolution having been duly and properly confirmed by a majority of those present at a subsequent meeting called at not less than fourteen days' notice, be found to have failed to conform to and carry out the said rule, then in such case his or their name or names shall be struck off the list, and notice of the same made public in such manner as shall be resolved." The above resolution was based upon the evidence of various experts, summed up in the following conclusions of Messrs. Stanger and Blount:— "Ragstone is a natural form of calcium carbonate mixed with silicious matter. It is an inert substance incapable of setting when gauged with water." "Ragstone when mixed with Portland cement undergoes no chemical change, and does not combine with cement either in the dry state or when the mixture is gauged with water." "Mixtures of ragstone and cement have a specific gravity lower than that of unmixed cement, and indeed correspond closely in specific gravity with that calculated from the respective specific gravities of the two materials. The specific gravity of normal ragstone may be taken as 2.70, and that of normal cement as 3.15, so that the difference between them is substantial." "Save for minor effects caused by the slight slaking action of moisture commonly present in ordinary ragstone, the part played by ragstone mixed with cement is purely mechanical. The product obtained from the two materials is merely a mechanical mixture, and is in no sense a chemical combination. In our opinion such a mixture cannot correctly be termed Portland cement." "Gypsum added to cement for the purpose of regulating the setting time in quantities not exceeding 2 per cent. of the weight of the cement, has no deleterious influence on the quality of the cement." With respect to other materials, Messrs. Stanger and Blount say that they are unable to give a general opinion as to their influence on cement when mixed with it, and that they would have to report separately as to each after long and careful investigation; and they express a strong opinion in conclusion that whatever be the effect, whether good or bad, of the admixture of any material whatever with Portland cement clinker after calcination, the article so produced cannot legitimately be termed Portland cement. Each of the other experts examined endorsed this view, and the Section approve and adopt it. At a meeting of the Society of Chemical Industry, held on November 1, 1897, a paper was read by Messrs. Stanger and Blount upon these subjects, when, after alluding to the investigations made for the section as to ragstone, they make the following remarks, for the reproduction of which the Chamber is indebted to the courtesy of the society and of Messrs. Stanger and Blount:— "Ragstone is not a

cementitious substance, and its addition to cement is an adulteration. Perfectly sound cement is weakened by the addition of ragstone. This weakening is not fully proportional to the percentage of ragstone added, because the latter acts as a fine filling material and fills up the interstices naturally present in set cement. Cement which is not perfectly sound may be temporarily improved by the addition of ragstone. When the cement has become sound by aeration this improvement disappears. Many minor points were examined and determined in the course of the main investigation, but the most important results are embodied in the conclusions given above. Additions to Cement other than Ragstone.—One of these which particularly came within our purview in the course of our investigation for the London Chamber of Commerce is gypsum. Gypsum is largely used in Germany, and to a considerable extent in this country, in quantities not exceeding 2 per cent., and usually smaller than this, in order to lengthen the setting time of the cement. Regarding cement as a chemically finished product in the state in which it comes from the kilns, needing nothing but mechanical comminution to make it saleable, the addition of any substance to the finished clinker must be considered in strictness an adulteration. Thus gypsum becomes under this definition an adulterant. Nevertheless, it is added for a distinct and useful purpose, and in quantities smaller than 2 per cent. does not affect the cement injuriously, so far as our experiments indicate. The last and worst adulterant with which it is our purpose to deal is blast-furnace slag. As far as our experience goes, this most objectionable addition to Portland cement is not employed on the Thames and Medway, but in certain other districts it is used in large quantities for the preparation of a grossly sophisticated product which is fraudulently sold as Portland cement. We must not be understood as condemning true slag cement, made by mixing granulated blast-furnace slag with slaked lime, and sold under its proper title. This material is a perfectly legitimate product, and has its own uses; no one can reasonably object to its utilisation if it is not covertly substituted for Portland cement. But the addition of blast-furnace slag to Portland cement is another matter altogether. The general practice of the manufacturers who seek to increase their profits by the use of slag appears to be to add to the clinker, as it goes to the crushers, as much crude blast-furnace slag as they consider can be mixed with Portland cement without risk of detection by the ordinary consumer, who buys cement in quantities so small that the cost of its analysis is too great for him to pay. The quantity added may be as much as 30 or 40 per cent., and detection is not easy or even always possible for an unskilled observer. Apart from the fraudulent character of this addition, about which no doubt can well be entertained, there arises the question of its effect on the cement. And here it is necessary to make a small digression into the chemistry of the subject." After stating their objections to the use of slag from the chemical point of view, Messrs. Stanger and Blount conclude their paper as follows:—"All materials added to Portland cement after the clinker comes from the kilns are adulterants, with the exception of gypsum, which is a recognised addition for a specific purpose in quantities not exceeding 2 per cent. Of the two adulterants which have been specially dealt with—viz., ragstone and blast-furnace slag—the latter is by far the more objectionable, and it should be condemned and rejected by makers and users alike. In this view we believe we are supported by the great majority of engineers and manufacturers."—By order of the Cement Trade Section. Publication committee: Charles Charleton, chairman of section (I. C. Johnson and Co., Ltd.); Ledham White, chairman of special admixtures committee (J. B. White and Brothers, Ltd.); William Porter (Burham Brick, Lime, and Cement Co., Ltd.); Kenric B. Murray, Secretary London Chamber of Commerce.

The following firms have signed the declaration:—Arlesley Lime and Portland Cement Co., Ltd., Arlesley, Beds.; William Ashby and Son, Ltd., London; F. C. Barron and Co., London; Booth and Co., Ltd., London; Borstal Manor Cement Co., Ltd., Borstal, Rochester; Burham Brick, Lime, and Cement Co., Ltd., London; Clitheroe Portland Cement Co., Ltd., Clitheroe, Lancs.; Dartford Portland Cement Co., Ltd., London; Dix, Green and Co., Saffron Walden; G. and T. Earle, Ltd., Hull; Formby's Cement Works, Co., Ltd., London; Francis and Co., Ltd., London; C. Francis, Son, and Co., Ltd., Isle of Wight; Gibbs and Co., Ltd., London;

Globe Portland Cement and Whiting Co., Ltd., London; Hilton, Anderson, Brookes, and Co., Ltd., London; Hooper and Co., Southampton; I. C. Johnson and Co., Ltd., London and Newcastle-on-Tyne; Laurence and Wible, London; W. Lee, Son, and Co., London; London Portland Cement Co., Ltd., London; McLean, Leveitt, and Co., Ltd., London; Martin, Earle, and Co., Ltd., London; New Rainham Portland Cement Co., Ltd., London; John Patrick and Son, Dovercourt, Essex; Peters Brothers, London; Phoenix Portland Cement Co., Ltd., London; Hon. Ashley Ponsoby, Artillery Cement Works, London; Addison Potter and Son, Newcastle-on-Tyne; Queensborough Cement Co. (Jaffray and Castle), London; A. and W. T. Richardson, London; Robins and Co., Ltd., London; Rugby and Newbold Cement Co., Ltd., Rugby; Walter Scott, Ltd., Newcastle-on-Tyne; Skelsey's Adamant Co., Ltd., Hull; South Wales Portland Cement and Lime Co., Ltd., Penarth, near Cardiff; W. Tingey and Son, London; Tower Portland Cement Co., Ltd., London; Truchmann, Weekes, and Co., Ltd., London and West Hartlepool; Tunnel Portland Cement Co., Ltd., London; West Kent Portland Cement Co., Ltd., London; Weston and Co., London; J. B. White and Bros., Ltd., London; Wouldham Cement Co., London.

## CHARTERHOUSE SQUARE.

[WITH PHOTOLITHOGRAPHIC ILLUSTRATIONS.]

TO this there are three entrances—Carthusian street, Charterhouse-lane, and Charterhouse-street. In each of the first two there once stood a gatehouse, the situation of which is now indicated by an iron gate surmounted by the arms of the hospital. This square is supposed to have been part of the ground first consecrated by Bishop Stratford as a place of burial. The square is inclosed and planted with trees and shrubs; an avenue of limes goes across it, which forms a shady walk in summer for the occupants of the houses around. The trees, considering the part of London they are in, preserve their verdure remarkably well. On the north side, as we enter the square from Carthusian-street, is to be seen the entrance to the hospital. The Gateway is the original portal of the monastery, and possesses many unmistakable indications of antiquity. It is a four-centred or Tudor arch, with dripstone terminating in plain corbels; over all is a shelf supported by two brackets representing lions, grotesquely carved, which may safely be ascribed to the early part of the 16th century. On the right as we enter is the porter's lodge, a modern erection. On the left is the residence of the medical officer of the hospital. Passing on, we find ourselves in the Entrance Court. From this there are two places of egress. A road lies straight before us leading to the quadrangles, the schoolmaster's house, the gown-boys', and the preacher's residence. Another on our left conducts us to the master's lodge, the hall, and the chapel. Under an archway leading to the master's court is the entrance to the Master's Lodge. Having viewed the interior of the master's lodge, we return to the Master's Court. On the left an arched passage leads us to the Washhouse Court, described hereafter. In the centre our attention is drawn to a porch surmounted by the Royal Arms, leading to the great hall and kitchen, whilst a passage on our right conducts us to the Chapel Court. This is surrounded by buildings on the south and west sides, the chapel on the east, and a colonnade or piazza on the north. This is denominated the Chapel Cloister, but it does not merit the name. A row of six heavy inelegant Italian semi-Classic arches on one side is all it possesses: there is nothing to attract the notice, save the extreme clumsiness of form and detail; in style it is almost nondescript. At the east-end of this specimen of debased architecture is a door in the same style, leading to the ante-chapel. Entering the Ante-Chapel, a small square chamber, at the east end of which is a modern screen, surmounted by the Royal Arms and those of the founder, Sutton. Through this a most beautiful view may be obtained of the east window. This chapel is vaulted and groined, a rib springing from a corbel in each corner; at the intersection of these ribs are bosses, ornamented with roses and foliage, and shields charged with instruments of the Passion. Here is placed the font. This is of stone and modern, but it is woefully debased. The ante-chapel bears the date 1512, and is in good preservation. At its east end is an equilateral arch leading to the chapel. The mouldings are distinct and good. It is filled up with the carved wooden screen before spoken of. This consists of a series of pointed arches, cinque-foiled, and through it we enter into the Chapel. The plan of this building is most difficult to describe, the present chancel being part of the original nave. It is square, divided in the centre by two

Tuscan pillars; a recess was added to the north side in 1826, and there is a tower at the west end, parallel with the ante-chapel. The south wall alone is part of the original church. It is supposed that the choir extended some way to the east beyond the present chapel. The pillars which divide it in the centre support three semicircular arches, the keystones of which are embellished with the Charterhouse arms. The roof is flat, ceiled and decorated, after the style of the time of James I. At the west end, under the tower, is an open screen of wood, carved in a style corresponding with the date of the rest of the chapel. This supports a gallery containing the organ. Its principal ornaments are grotesque, puffy-faced cherubim, helmets and swords, drums and instruments of music, and in the centre is a shield, tied up with a thick cable, charged with the arms of the Hospital. The altar is of wood, and on each side in the corner of the chancel is a sort of stall, the one on the right being appropriated to the head, and that on the left to the second master of the school. The east window is of five lights under one arch, and is filled with painted glass. The pulpit and reading-desk are against the south wall, as also are the masters' and preachers' pews. The seats for the pensioners are open, and have poppy-heads in the shape of greyhounds' heads couped, ermine collared gules, garnished and ringed or, on the collar three annulets of the last, the crest of the hospital. The scholars sit in the recess to the north. The founder's tomb is on the north side of the chancel. In leaving the chapel by way of the cloister, our attention is drawn to a small door on the right; this communicates with a spiral staircase leading to the roof of the tower. The tower is square, and is surmounted by a heavy Italian parapet, with a thing in the shape of a pinnacle at each angle. The whole is crowned with a wooden dome resting on pillars supporting semicircular arches. Returning by the cloister we stop at a door on the right which conducts us to Brooke Hall. This room is now used as a dining-room for the officers of the house, where they meet daily and occasionally introduce a friend to participate in the bounty of Sutton. Retracing our steps along the cloister we enter a small paved hall, and to our right we spy the foot of the Great Staircase. This is magnificently carved with Arabesque ornaments, of somewhat the same character as those on the gallery of the great hall. It is 6ft. wide, and consists of 21 steps. Midway there is a large window looking in the Master's Court. Arriving at the top, we see on our right the entrance to the apartments of the Reader, on our left an ante-chamber conducts us either to The Terrace, a fine paved walk of nearly 80 yards, commanding a view of the green, or to The Library, which we enter through a door on our left. This contains a valuable collection of erudite and scarce works. Adjoining is the Governor's Room, the decorations of which date about the time of Elizabeth, and are of the most magnificent description. The ceiling is flat, and is adorned with the armorial distinctions of Thomas Duke of Norfolk. Retracing our steps down the great staircase, we come to the Great Hall. This is the most ancient of the buildings which date subsequent to the Reformation, the west wall being part of the conventual edifice. It was most probably built by Sir Edward North, who obtained the Charterhouse for his private residence in 1535. At the west end is a spacious music-gallery, which, from the style of carving, as well as the letters "T. N." and the date 1571, appears to belong to the period when the unfortunate Duke of Norfolk was a prisoner in his own house. This communicates with a smaller gallery at the side of the room which was used as a passage from the great staircase to other parts of the house, and is of the same antiquity as the hall. The roof is plastered, panelled with wood, and arched in the centre. The room is lighted by three large windows, which have four centred arches, and four smaller square-headed ones. They consist of five lights, transomed and super-mullioned. One is sunk in a recess, with panel-work, sculpture descending to the ground. The chimney-piece was an addition by Sutton, and is of later date than any other part of the building. It is carved in stone, but is of grotesque design, consisting of imaginary scrolls, in the style of the Renaissance school. The arms of the founder, surmounted by helmet, are well executed, as also are two small pieces of ordnance on each side, which are boldly, yet accurately, wrought. Beneath these, and in the centre above the space

allotted to the stove, is an oval upon which is carved a dragon, but it is now much mutilated. This room is now used as a dining-hall for the pensioners. A door on the right opens into the Upper Hall, which is a small low room, devoid of all ornament except the chimney-piece, which is carved in stone, and has the founder's arms sculptured above. The windows are square-headed. It is now used as a dining-hall for the scholars on the foundation. Returning through the great hall, we make our exit through a door under the music gallery, which opens into a stone passage, on the right of which are the apartments of the manciple. On the left, an outlet opens into the master's court, and in the centre are three doorways of depressed Tudor arches within a square head, the spandrels being filled with roses, foliage, and angels bearing shields. These lead to the Great Kitchen, which gives the stranger some idea of the immense consumption of the house. Retracing our steps through the master's court and entrance court, we direct our course to the gown-boys and green, a road which we avoided on our first setting out. Proceeding, therefore, down this road, we come to another gateway, more ancient than the outer one, but which possesses no ornamental attractions. A doorway on the right opens into the Abbot's Court. Of all the courts this is the most ancient. It is sometimes called Wash-house Court. Returning, we enter the Preacher's Court. This is a range of new buildings, castellated and turretted, built in the year 1825, after the designs of Edward Blore. In the centre of the north side is a gateway with an octagonal turret on each side, one of which contains the bell, which sounds regularly every quarter of an hour before the meals of the pensioners. On the west side are apartments for some of them. On the south and east sides is a paved cloister, and at the south-east angle is to be seen the large west window of the governor's room, above which are five shields, excellently carved in stone. The gateway in the centre of the north side has a depressed Tudor arch within a square head, the spandrels of which are filled with shields charged with the Charterhouse arms. The parapet above is embattled. This leads to the Pensioners' Court. This is of the same date as the preceding, but does not boast of the cloistered walk which beautifies it. In the centre of each side is a fine gateway, similar to the one before described as opening into this from the Preacher's Court, but without the two octagonal towers. The one on our left opens into the stable-yard and servants' apartments; that on the north side into the burial ground; and that on our right into a passage which divides it from the schools.

WALTER H. BOURNE.

[We hope to give the general plan and elevations at an early date.—ED.]

#### DANGEROUS FLOORS.

ACCORDING to the accounts recently published in the Canadian papers on the late disastrous collapse of a crowded floor in London, Ontario, which we noticed in our last issue, the jury empanelled to investigate the circumstances have returned a verdict, "That more than ordinary care was used in the construction and selection of material, and that the sad occurrence was purely accidental." This is surely unsatisfactory if we take the facts as they have been reported, to which it is needless again to refer. From what we gather, the public hall was 72ft. long and 42ft. wide, with a platform at one end. The people in the hall appear to have crowded round the platform in a rather excited manner. A portion of the floor in one corner, including the platform, gave way, and precipitated the mass upon the floor below. The load, according to the *Canadian Architect*, was chiefly carried on a beam 21ft. span, and was distributed on an area of flooring about 28ft. by 22ft. The total area of floor bearing on beam was, it is said, 249sq. ft., and the weight of floor itself is estimated at 25lb. per square foot. As to the live load actually bearing on the beam at the time of the accident no exact information is forthcoming, though it is calculated by our contemporary, allowing the weight per person at 135lb., that a total live load of 33,760lb. was over the entire space which gave way, or a live load on the beam of 16,875lb. But the exact condition of the crowd and their movements are not known, and therefore any conclusions from these figures are impossible. For correct calculation it would be necessary to find out how the people were distributed, whether they were

merely standing or jumping; how many really were standing over the beam which gave way, and which we are told was 12in. by 14in., composed of four pieces, each 3in. by 14in., spiked together, though not securely. According to Kidder, whose estimate is not high, such a beam, if sound, would carry safely 13,440lb., allowing a factor of safety of 4, and according to the calculation of our contemporary the load on the beam may be taken at 40,350lb., a load which it was incapable of supporting according to the evidence of a witness. We have here the salient points of the case. A beam of the dimensions and construction stated, if properly made, according to the best authorities, should at least have been able to carry without breaking the actual load of floor and people that came upon it, though that load exceeded the factor of safety. But it gave way. We have here another proof of the valuelessness of calculating strength when other conditions are wanting—those, for example, of good material and execution. This beam clearly failed from imperfect material or method of bolting; the wood was seriously weakened by knots, which robbed it of a large percentage of its strength, or the pieces of which it was composed—according to report, four pieces 3in. by 14in. spiked together—were inadequately joined to take their share in the resistance. One witness says the pieces could "move one on another," thus destroying the value of a bolted beam; further, that they were only spiked together instead of being bolted. If these allegations are true, we have here another instance of a beam designed rightly to carry such a load, but rendered incapable of doing so by carelessness of workmanship. It would have been safer to have trusted to a solid timber beam of the same scantling. The incident in its terrible consequences should be a lesson to architects and builders, never to trust to bare calculated strength alone. There are so many other elements to consider in beams—soundness of timber, freedom from knots, perfect bolting together. Then sudden impact, such as jumping or any synchronous movement of a crowd of people, as a tread or a dance, unequally increases the live-load enormously, and one authority puts the effect of jumping at over half per cent. on the still load. Of course, every floor to a public hall ought to be strong enough to be able to resist this severe strain, and to withstand any kind of treatment. So that the architect ought by no means to be satisfied with his calculated results, but allow a full margin for all the above causes of weakness and increase of stress. Nor can we say that the jury did their best to investigate the cause of the catastrophe. To say the fall was due simply to accident, and that more than ordinary care was used in the construction and selection of material, is an extraordinary verdict.

#### THE OUTLAY ON BROOK HOSPITAL.

AT Saturday's meeting of the Metropolitan Asylums Board the annual financial statement was submitted by Mr. A. C. Scovell, from which it appeared that the total expenditure of the managers for the year ended Michaelmas, 1897, amounted to £665,393—an increase of £40,270 upon that for the previous year. This increase was mainly accounted for by the opening of the Brook Hospital, involving an additional expenditure of £33,000. Upon the presentation of the report of the special committee in the matter of the Brook Hospital expenditure, Mr. James Brown said that his name had that day been mixed up by certain London newspapers with what was said to be a gross scandal in connection with the erection of the Brook Hospital. He had been accused of supplying the bricks which were used in the construction of that hospital, but the charge was devoid of foundation. Mr. Brown explained that he was the maker of a special sort of ornamental brick, which was used by builders all over the country, and that a comparatively small quantity of the bricks which had been supplied by him to merchants in London had been used in the ornamentation of the Brook Hospital. It was, he said, done without his knowledge, and it was a matter over which he had no control. He thought the way in which the matter had been brought up was a gross injustice.

Mr. E. White moved the adoption of the committee's report. In this it was stated that the original estimate for the erection of the Brook Hospital was £194,810, and the amount of the

tenders ultimately accepted £218,171 16s. 2d., whilst the amount which the managers were asked to pay in settlement of the contractors' final claims was £268,507 11s. 2d. The difference between the total amount of the accepted tenders, £210,018 0s. 4s., for which the architect was responsible, and the total amount for which he was prepared to certify in settlement thereof, was £49,383 14s. 8d., of which £10,723 appeared to have been sanctioned by or reported to the Board, leaving the balance to represent the value of work ordered on the architect's individual responsibility over and above the value of the works for which tenders were accepted by the Board. Mr. Aldwinckle, the architect, was blamed by the committee for having under-estimated the amount of work necessary in many cases, and for making no provision in his original estimate for many incidental matters. While he estimated that the cost of extra foundations was about £5,000, the actual value of the measured and certified work amounted to nearly four times that amount.

Mr. J. H. Brass moved, as an amendment to the committee's recommendation, that the contractors' claims as finally adjusted be approved, "That the report be referred back to the committee for them to report as to the cause of extra expenditure, as to the several contractors not executing the work in accordance with their sealed contracts, as to the power of the architect to order additional work without the authority of the Board, and as to whether the certificates of the architect for such work were not *ultra vires*." After some discussion the debate was adjourned.

#### IRON UPRIGHTS.

THE series of tests made at Hamburg to show the behaviour of uprights for warehouses when subjected to heat or fire are of some value. They point to certain conclusions—namely, (1) that wrought-iron uprights, if not protected, show little resistance at a fire, and may collapse in temperatures exceeding that of 1,100° Fahr.; that (2) wrought-iron uprights, if protected by concrete—as, for instance, by filling in the kernel of the framing—offer a somewhat greater resistance than if entirely unprotected; (3) if these uprights are protected by non-conducting materials they show a much greater power of resistance than cases 1 and 2; (4) that cast-iron columns (unprotected) offer a slightly greater resistance than wrought-iron uprights, the collapse taking place at temperatures above 1,400° Fahr.; (5) cast-iron columns require considerable attention as regards section and maximum load when used in dangerous buildings, as the time of collapse differs very materially, according to weight during a fire and their plan; (6) if protected with non-conducting materials, cast-iron columns show a greater resistance than wrought-iron uprights so protected; (7) wooden uprights, if unprotected, catch fire at a temperature under 1,100° Fahr.; but, though well alight, show greater resistance than unprotected wrought-iron or cast-iron uprights; (8) all these kinds of uprights in no case give any sign of impending collapse.

These conclusions are instructive. Nos. 3 and 7 are very important. The value of protection is established, but particularly that afforded by "non-conducting materials." No. 7 ought to make all architects and engineers think. Wooden supports collapse only at a temperature a very little short at which wrought-iron ones yield if left unprotected. The difference between wrought and cast iron is assumed to be greater than these tests show. Most architects are under the impression that a wrought-iron column is more fire-resisting than cast iron, that it is less likely to crack under fire and water, and this is undoubtedly the case; but they are not prepared to learn that a cast-iron column protected has a much greater resistance than one of wrought iron similarly treated.

A new public hall is about to be built in Fountain-street, Halifax, from plans by Mr. W. C. Williams. It is proposed to provide a hall with a seating capacity of 2,510, and a lesser hall holding 336 persons.

Mr. Howard Martin, the arbitrator in the claim brought by Mr. Gill against the South-Eastern Railway Company, for the value of the property known as 34 and 36, Dockley-road, Bermondsey, taken under compulsory powers, has issued his award at £1,065. The expert valuations handed in on behalf of the claimant ranged from £1,676 to £1,775 10s.; those for the railway company from £824 3s. to £914.

#### BOOKS RECEIVED.

*Sewer Gas, and its Influence upon Health*, by H. ALFRED ROEHLING, C.E., Assoc. M. Inst. C.E., &c. (London: Biggs and Co., Salisbury-court, Fleet-street), is an exhaustive treatise on the subject dealing with several aspects instead of only one or two points. The author, in fact, investigates the subject from several standpoints. Chemical research, medical science, bacteriological, and engineering inquiry have been brought to bear. The earlier chapters treat the later developments of the inquiry, the history of sewer gas controversy, the theories of Murchison and of Budd, American and Continental views, the present state of our knowledge, the conservancy methods, and the water carriage system. The author speaks of the sanitary and other advantages of this system over the conservancy methods. An important chapter is that on micro-organisms in sewer air, in which various experiments are referred to to ascertain whether germs can be carried away by air currents in pipes and sewers. Summarising these, it is held that pathogenic germs meet with conditions in sewers unfavourable to them, such as the myriads of other germs that crowd the sewage, and which struggle for existence; that these micro-organisms cannot rise from liquids and moist surfaces; and that there is a comparative absence of germs from sewer-air. The report of Messrs. Laws and Andrewes is mentioned, to show how difficult it is to catch the typhoid germ, even in sewage from the Homerton Hospital. At a mile below this institution, not a single colony of the bacillus was found in the drainage. The experiments on animals are detailed. These show that 75 to 100 per cent. of all animals inoculated with small doses of attenuated typhoid bacilli, after exposure to sewer-gas, perished, while not one of the animals kept under normal conditions succumbed to the inoculation, proving that putrid gases, including sewer-gas, predisposes animals to the pathogenic action of the germ. The appendices and tables given at the end of the volume are instructive.—*The Cathedral Church of Winchester, &c.*, by PHILIP W. SERGEANT, late scholar of Trinity College, Oxford (London: George Bell and Sons), is another of the useful and admirably got-up series of monographs of our cathedral churches now issuing, under the title of "Bell's Cathedral Series," edited by Gleeson White and E. F. Strange, several of which we have noticed. This volume on Winchester has been compiled by Mr. Philip Walsingham Sergeant from authenticated sources, such as Prof. Willis's paper, and is illustrated by numerous sketches and phototypes by The Photochrom Co., Ltd.; S. B. Bolas and Co. have chiefly supplied the negatives. The views of the choir-stalls, and the beautiful altar and carved retables, lately restored; Beaufort's and Foxe's Chantries, Wykeham's Chantry, Langton's Chapel, and the noble nave of Wykeham, are excellent representations. Other illustrations are from drawings and sketches. An excellent plan of the cathedral and one of the crypts, with references to the chantries and tombs, are given at the end. Brief notices are appended of Winchester College, the Hospital and Church of St. Cross, and other antiquities. The beautiful iron grill from St. Swithin's shrine, from Mr. Starkie Gardener's book, lent by the Science and Art Department, is one of the illustrations. The descriptive matter is as far as possible correct and concise, and the book published at the low price of 1s. 6d., will be found an invaluable handbook to the general reader and tourist. Much valuable information respecting the history and structure of this fine example of Mediaeval architecture in its earlier and later phases is condensed in Mr. Sergeant's book. The series will entirely supplant the poor and meagre guide books of our great cathedral establishments.

—*The Cathedral Church of Lichfield*, by A. B. CLIFTON, is another of the series. The author in this history has been less fortunate in the choice of his authorities. There are fewer reputed authorities to consult, but a number of journals and pamphlets have been put under contribution. The result is, however, satisfactory. For the general reader or student the information is all that he can desire; the photographs from the same firm as we noticed above have been reproduced, and make clear and crisp pictures. As Mr. Clifton says, while other cathedrals are larger or grander, Lichfield is more charming and jewel-like. Every detail in it is beautiful. Take a bay of the nave: what can be more perfect or refined in the Middle Gothic

or Decorative period, or a bay of the choir with its beautiful traceried window and mouldings? Take the fine clustered pillars and capitals in the choir, or the side doorways of west front with their beautiful foliated tracery over, or the grand central one with its cusping and carved arch members and sculptured jambs—all of the same perfect 14th or 15th-century richness. The tourist and student cannot provide themselves with a better manual.—*Sell's Dictionary of the World's Press and Annual of Useful Knowledge for 1898*, is still further enlarged, although, for the purpose of gaining space, the whole of the lists of papers, &c., have been reset. Particulars of every newspaper published throughout her Majesty's dominions are given, together with the principal foreign papers. Many articles of great importance to commercial men generally (other than editors, &c., who are more particularly interested in the newspaper world) will be found.—*Laxton's Builders' Price Book for 1898* still maintains the honourable position: it has so long enjoyed among architects, surveyors, builders, and contractors. Great care has been exercised in the preparation of the work so as to bring the prices and other information up to date, based upon the latest quotations of the price of materials, and throughout the compilation thereof the aim has been to make it as accurate and complete as possible. Important decisions under the New London Building Act, 1894, in the superior Courts and the Tribunal of Appeal are stated in detail, and "heads of cases" brought before the police-courts under the same Act are also given.

#### CHIPS.

The Leicester Town Council have by an almost unanimous vote, decided to exercise the right they have obtained under their new local Act by erecting a crematorium in their new cemetery at Silroos.

Great progress has been made with the erection of the new ironworks for Messrs. Lysaght and Co., of Bristol and Wolverhampton, on the east side of the River Usk at Newport, Mon. Three large buildings have been erected, and three boilers have been laid down. A number of annealing furnaces are now in working order, and a preliminary trial of a 500H.P. engine for working three rolling mills was made on Friday. The plates will be sent to Bristol to be galvanised. The Great Western Railway Company are laying a siding to the works from the new East Usk Railway.

The shareholders of the Maidstone Water Company, at the private meeting held on Thursday last week, approved a draft agreement for the sale of their undertaking to the corporation of Maidstone. The directors were also empowered to proceed with a scheme for forming an auxiliary company or syndicate for obtaining a further supply of water.

At the recent session of the Legislature of the Province of Quebec a Bill, No. 87, was passed, making several amendments to the Act of Incorporation of the Province of Quebec Association of Architects, chief among which is one which restricts the use of the title "Architect" to persons who shall register under the Act. The amending measure has now received the assent.

On Saturday the members of the Edinburgh branch of the Amalgamated Society of Carpenters and Joiners paid a visit of inspection to the M'Ewan Hall. Including a few lady friends, nearly 300 availed themselves of the opportunity of seeing the great building, and Mr. Allan E. Clark, the clerk of works, carried out the arrangements. Mr. Clark gave some particulars regarding the construction of the hall, its dimensions, and architectural features. He further described the art-work and the organ. Thereafter the sightseers walked round the building, when all explanations were afforded by Mr. Clark, the engineer, and others.

The Leeds Sanitary Committee have recommended the council to accept tenders for lighting and heating the hospital pavilions at Maunston. The tenders amount to between £3,000 and £4,000.

On Thursday week, the city council of Chichester elected Mr. James Saunders, A.R.I.B.A., assistant borough engineer of Oldham, to the post of city surveyor and waterworks engineer. There were 115 applicants for the appointment.

The extensions to the hospital, Lowestoft, are being warmed and ventilated by means of Shorland's patent Manchester stoves, the same being supplied by Messrs. E. H. Shorland and Brother, of Manchester.

The memorial stone of a new Baptist chapel, to be built on the Grove Estate at Lowestoft, was laid last week. The tender of Mr. J. Ashley, of Lowestoft, has been accepted at £3,540 for the new building, which will be seated for 700 persons.

## OBITUARY.

MR. EDWARD J. PURNELL, JUN., architect and surveyor in the Coventry district, died on Sunday from consumption. The deceased designed many of the new cycle factories and the extensions at former factories in the city, and had several important works in hand at the time of his death. He was surveyor to the Kenilworth Highway Board, and manager to the Kenilworth water-works.

The death is announced of Mr. JAMES FRÉRET, of New Orleans, one of the most distinguished architects of the Southern States. Mr. Fréret was born in that city in 1838, and educated at the Jesuit College, going thence to the School of Fine-Arts in Paris, where he was a fellow student with the late H. H. Richardson, himself a native of Louisiana. At the outbreak of the Civil War, Mr. Fréret returned to New Orleans, and joined the Confederate Army. He was severely wounded at the siege of Fort Hudson, and was taken prisoner, and, though afterwards exchanged, was permanently disabled. At the close of the war he entered upon the practice of his profession, and designed many of the most important buildings in New Orleans, including several churches. He was at one time a prominent candidate for the position of supervising architect of the United States Treasury Department.

We regret to announce the death of the wife of Mr. Ellis Marsland, district surveyor for Camberwell, and the genial and energetic honorary secretary of the Society of Architects. Mrs. MARSLAND died at their residence, 73, Sydenham Hill, S.E., on Thursday in last week, five days after giving birth to a son. Mr. Marsland's first wife died very suddenly some years since.

SIR WILLIAM M'CAMMOND died on Wednesday at his residence, Walton, Port William Park, Belfast. He was the son of Mr. James M'Cammond, of Ballyduff, county Antrim, and was born in 1831. Since 1840 he had carried on business as a builder and contractor in Belfast, and had risen to the leading position in the trade in that city. He became one of the Water Commissioners for the city in 1877, being chairman from 1882 to 1885, and a member of the City Council in 1880. He filled the office of chairman of the Improvement Committee of the Council from 1884 to 1894, and was Lord Mayor for two successive years from 1893 to 1895, being knighted in the latter year. During the engineers' lock-out of 1895, Sir William was associated with Lord James, and the then Lord Provost of Glasgow, in bringing about a settlement of the dispute.

MR. ARCHIBALD ALLAN, C.E., burgh surveyor for Govan, died suddenly at his office, Hillock House, on Friday. Mr. Allan attended a Dean of Guild Court at ten o'clock, and he then returned to his office, where he was seized with illness and died shortly after, the cause being cardiac apoplexy. Deceased was a native of Glasgow, and was appointed burgh surveyor of Govan in 1880, and during his connection with the district he prepared plans for most of the large streets, while public halls and burgh buildings are at present being constructed from his plans. He was 46 years of age, and unmarried.

A new organ has just been opened in St. Mark's Church, Saltney, near Chester. It was built by Messrs. H. and H. Whiteley, of Chester and Saltney. The case, which is of oak, was designed by Mr. T. M. Lockwood, F.R.I.B.A., of Chester, and was made by Mr. Freeman, George-street, in that city, under the direction of Mr. W. Patison. The decorations of the front pipes were designed and carried out by Messrs. Ellis, Foregate-street, Chester.

At Paisley on Saturday the statues of the late Mr. Thomas Coats and Sir Peter Coats were formally unveiled. The statues of the brothers are erected on a terrace leading from the High-street into Dann-square, and have been executed by Mr. W. Birnie Rhind, of Edinburgh, whose model was selected in competition. Sir Peter is represented with his frockcoat thrown back by the left hand, the right hand grasping the lapel below the collar, whilst Mr. Thomas is placed in a reposeful attitude, his frockcoat buttoned, and over it his topcoat. The pedestal of the Sir Peter statue is square in outline. There are pillars at the corners, and niches and panels on each of the four sides, and on these are placed symbolic figures representing "Frugality," "Industry," "The Arts," and "Literature." The pedestal of the Thomas Coats statue is of white marble, the angles being rounded off, and the panels, with symbolic figures in bas-relief, represent "Prudence," "Perseverance," and "Liberality."

## PROFESSIONAL AND TRADE SOCIETIES.

ABERDEEN SOCIETY OF ARCHITECTS.—The annual meeting of this society was held on the 1st inst. when the following office bearers were elected:—President, Mr. James Souttar; vice-president, Mr. Arthur Clyne; hon. sec. and treasurer, Mr. John Rust; members of council: Mr. Wm. Kelly, Mr. A. M. Mackenzie, Mr. A. H. L. Mackinnon, Mr. George Watt, Mr. R. G. Wilson.

ELECTRIC LIGHTING FOR THE HOUSE.—At a meeting of the architectural section of the Philosophical Society of Glasgow held on Monday, Mr. William Arnot, formerly electrical engineer to the Corporation of Glasgow, read a paper on the distribution of electricity in the house. He said that no one yet knew what electricity really was, but that it could be measured as accurately as any matter by its effects. The units, in which we spoke of the pressure and quantity of electricity, were now well defined, and could be easily determined, thanks to Lord Kelvin, Lord Raleigh, and other eminent scientists. After speaking of the different units, he described the distribution of current by means of the three wires, which is the system now universally adopted. He then went over in detail the different fittings in a house, and the different systems of wiring. He was of opinion that switches should not be spared, as they tended to reduce the annual bill for current. Fuses should also be placed in suitable boxes, and not scattered over the house in inaccessible places, even though the cost was a trifle more under such a system. He thought more taste could be expended on fittings—not so much brass and more light—and that the positions of the lights should tend to decorate a room rather than burden it.

GLASGOW ARCHITECTURAL ASSOCIATION.—At the monthly meeting of this body, the president, Mr. W. T. Connor, in the chair, Mr. J. A. Williamson, A.R.I.B.A., as delegate from the Edinburgh Architectural Society, lectured on "The Wren School." The lecturer approached his subject by a prefatory sketch of Wren's great predecessor, Inigo Jones; then, taking up the great master himself, described in a clear and concise manner his most characteristic works, closing with a careful criticism of the productions of Wren's successors, and in particular Gibb, Vanborough, and Hawksmoor. The lecture was illustrated by limelight views of buildings and original drawings by the architects referred to. At the close a hearty vote of thanks was passed.

MANCHESTER SOCIETY OF ARCHITECTS.—At a meeting of this society, held on Tuesday night at the Standard Chambers, Mr. John Ely in the chair, Mr. J. H. Reynolds, director and secretary of the Manchester Municipal and Technical School, read a paper on "Technical School Buildings." He said that in the construction of the Manchester Corporation Technical School in Sackville-street advantage had been taken as far as possible of the experience gained in the erection of similar buildings elsewhere, and that in consequence there were many matters of professional and technical interest connected with it. Schools differed, however, so much in aim, resources, scope, site, and other circumstances, that one rarely found the methods adopted in one place just those best suited to the conditions and requirements of another. As an illustration of this, he pointed to the absolute necessity of providing for the greatest possible amount of light in buildings situated in a city like Manchester, which, by reason of the narrow streets and the pall of smoke which overhangs it, enjoys but little of the blessed light of the sun. The question of fenestration assumed vital importance under such conditions, and virtually determined the style of architecture, or at any rate limited the range of choice. From this point of view, the Gothic style, as exemplified in the town-hall or in the Owens College, was to be condemned. So, too, was a style of architecture which required for its best effects heavy projections and consequent deep and widely-extended shadows, or, again, a style which demanded small windows for the sake of gaining picturesque or quaint results. He knew that architects delighted in the sense of repose which was derived from large blank wall space as a relief from window openings and other distracting features of the elevation of a building, but that it was possible to make a satisfactory compromise between the demand for light and architectural conventions was seen in

the building of the Williams Deacon and Manchester and Salford Bank in Mosley-street, and in the warehouse recently erected by the Tootal Broadhurst Lee Company in Oxford-street. Mr. Reynolds proceeded to offer suggestions as to the means by which beauty and utility might be obtained in technical school buildings. His paper was illustrated by a number of limelight views. On the motion of Mr. Edward Salomons, seconded by Mr. J. H. Woodhouse, a vote of thanks was accorded to Mr. Reynolds.

SOCIETY OF HOUSE DECORATORS AND PAINTERS.—The general council delegate meeting of the above society was held last week in Bristol, and attended by delegates from various parts of the country. Mr. E. C. Thackwell, of Plymouth, was chairman, and Mr. W. F. Wallis, Croydon, vice-chairman. The society is a sick-benefit society as well as a trade organisation, and the twenty-fifth annual report issued by the general secretary, Mr. E. C. Gibbs, shows that the membership at the end of 1897 was 3,728, an increase of 341 during the year. The income for 1897 was £4,158, making, with the balance brought forward, a total of £8,034. The year's expenditure was £3,237, leaving a credit balance of £4,797, and showing a clear gain of £920. It may be mentioned that during the twenty-five years of its existence the society has paid £15,534 in sick benefits, and £3,135 for funerals, while the strike pay and trade protection expenses have absorbed only £3,039. The chief purpose of the delegate meeting was the revision of rules.

## CHIPS.

The will of the late Mr. Donald Munro Drysdale, of Princess-road, Liverpool, timber merchant, has been proved; the gross personalty is £19,807 5s. 6d., and the net £19,692.

The annual meeting of the Royal Archaeological Institute will be held at Lancaster from Tuesday, July 19th, to Tuesday, July 26th.

Tettenhall Wood Church was re-opened on Sunday, after undergoing internal renovation, which has been carried out by Mr. Heath, from the designs of Mr. T. H. Fleeming, of Wolverhampton.

A instance of zeal in the service of the church comes from Southey, Lincolnshire, where the curate of Bardney (the Rev. Mr. Knox), who is said to have qualified as an architect before entering the church, is now acting as clerk of the works, foreman of building operations, joiner, bricklayer, and general labourer on the felt-lined wooden church he has himself designed.

The chapel of St. Edmund's R.C. College, which has been closed since Christmas for alterations and improvements, was solemnly reopened last week. The changes include an additional row of stalls, while the floor of the whole chapel and sacristy has been renewed; the sacristy has been laid with parquetry, and the chancel is tiled. The architect is Mr. Austin Heyes, of Fulham.

The Light Railway Commissioners concluded a lengthy inquiry at Bournemouth on Friday, with respect to applications by two electric tramway companies, for powers to construct lines connecting Bournemouth, Poole, Christchurch, and suburbs. Strenuous opposition was offered by the Bournemouth Town Council to any tramways being laid within the borough, and the commissioners decided that no public necessity had been proved to induce them to overrule the decision of the council, or to authorise any remaining portions of the two schemes which lay outside the borough.

The property market at Tokenhouse-yard is in a healthy condition just now, and when properties are brought into the market with reasonable reserves there is very rarely a lack of buyers. The aggregate realisation for the week at the Mart is £142,072, which again shows an advance over the amount registered in the corresponding week of last year.

Colonel A. J. Hepper, a Local Government Board Inspector, held an inquiry at Gainsborough on Friday in respect to an application by the Urban District Council for sanction to borrow £2,500 for the purchase of land for the purposes of public offices, street improvement, and market accommodation. Evidence in support of the application was given by the clerk (Mr. D. M. Robbs), who stated that since 1871 the population had increased from 7,564 to 19,187.

The laying of the foundation-stone of a new Roman Catholic church of Our Lady of Perpetual Succour at Gillingham, near Beccles, took place on Thursday in last week, according to the Roman Pontifical. The building will be of red brick, with stone dressings, and will consist of sanctuary, sacristy, confessional, lobby, nave, and campanile about 60ft. high, the dimensions of the church being 77ft. in length and 22ft. wide.

## Building Intelligence.

**COXLIDGE, NEWCASTLE.**—The city lunatic asylum for Newcastle-on-Tyne, at Coxlidge, near Gosforth, is nearing completion. The original asylum was opened about 31 years ago, the main building accommodating 300 patients. Two wings, for male and female patients, were added in 1835, increasing the accommodation by 150 places. Not long after the committee added to the estate some 28 acres of land, and half a dozen years since invited competitive plans from local architects for buildings for 350 patients. Those by Mr. J. W. Dyson, of Newcastle, were selected by Mr. G. T. Hine, the assessor, and are now being carried out. Mr. John Ferguson was the contractor for the foundations, and Mr. Walter Scott, also of Newcastle, for the superstructure. The extension will accommodate 361 male patients. The buildings are arranged in two-story blocks, the external walls being of stone, and roofs of Bangor slates. The patients' blocks have the space between ground-floor ceiling and first floor constructed on Messrs. Mark Fawcett and Co.'s system of improved fireproof flooring, the ceilings to upper floors being of concrete. The ordinary floors and woodwork generally are of pitchpine; the lavatories, bath rooms, corridors, &c., being lined with glazed bricks, and the staircases being built of Yorkshire stone. The heating and ventilation are on the plenum system, the apparatus being placed below the buildings in subways. The heating and ventilating arrangements have been placed with Messrs. Ashwell and Nesbit, Newcastle and London. Doulton's manufactures are being employed for the sanitary fittings. The building contracts have cost £12,000, and £113,311 for foundations and superstructures respectively.

**HANDFORTH.**—The foundation-stone of the new church of St. Chad was laid on Saturday, Feb. 19. The church is designed in the Perpendicular style of architecture, with half-timber gables and other details characteristic of the buildings of Cheshire. When completed, the edifice will consist of nave, chancel, north and south transepts, organ-chamber, and clergy and choir vestries. At the south-west angle of the building will be a belfry-tower, the tower-stage forming an entrance-porch. The church is arranged to give accommodation for about 300 sittings when completed. The work is being carried out under the supervision of Mr. John Brooke, A.R.I.B.A., 18, Exchange-street, Manchester. The contractor for the work is Mr. Thomas Browne, of Chester.

**STONEHAVEN.**—A granite residence has just been completed at the junction of Bath-street and Slug-road for an English gentleman, and will be used as his summer residence. It is Scottish Baronial in style, the south and west elevations (which are the exposed ones) being built in Kemnay granite, and the ashlar rock-faced, with fine picked dressings. The front elevation is 72ft. in length, the centre turret rising to a height of 55ft. The roof is covered with Tiberthwaite green slates, and the ridge has an iron cresting. The inside finishings are all of American poplar, known as canary weed, except the staircase, which is of pitch-pine. The hall containing the staircase is lit by a cupola from the roof, and forms one of the principal internal features. The following contractors have carried out the various works:—Mason work, Mr. George Gregory, Stonehaven; carpenter work, Messrs. R. Thomson and Sons, Stonehaven; slater work, Mr. Charles Maitland, Aberdeen; plumber work, Mr. A. Mathieson, Stonehaven; plaster work, Messrs. Scott and Sellar, Aberdeen; painter and glazier work, Messrs. Barron and Son, Aberdeen. The building was designed and carried out under the superintendence of Mr. J. Augustus Souttar, architect, Aberdeen.

**SALISBURY CATHEDRAL.**—The work of restoring the spire and turrets of Salisbury Cathedral, which has been in progress during the past two years, is now almost completed, and in the course of the next few weeks it will be entirely finished, and the scaffolding, which at the present time envelops the tower and a large portion of the spire, will be removed. The work has been carried out under the direction of Sir A. W. Blomfield, A.R.A.; and in a recent report to the committee he informed them that the turret at the north-west angle of the tower was in such a bad state that it was needful to take it down. It

has been rebuilt. Every stone that could be reused appears again in its proper place, only new stones being introduced wherever the original stonework has been crushed, broken, or in such small stones as to be unsafe. The turret staircases at the four angles of the tower, which have to support so much of the enormous thrust of the spire, have been repaired and strengthened. On all four sides defective masonry has been taken out and replaced by new stones weighing in some cases upwards of a ton. The foundations of the south aisle and of the west side of the south transept have yet to be repaired. Altogether the cost of the work will be about £15,000, of which £1,400 remains to be raised.

### CHIPS.

The Jubilee Schools for Girls at Conway, erected at a cost of £1,500, were opened on Monday week by Mr. J. Ernest Greaves, the lord-lieutenant of the county.

A Victoria Wesleyan Hall has just been built in Knowsley-street, Bolton, at a cost of £30,000, including purchase of portion of site. The architects are Messrs. Bradshaw and Gass, of Bolton.

An extensive block of buildings to be occupied by Messrs. W. A. and A. C. Churchman, wholesale tobacconists, has just been erected at the corner of Prince's-street and Portman's-road, Ipswich. They are of red brick, and are fitted with the electric light. Mr. J. Shewell Corder, of Ipswich, was the architect, and Mr. Fred Bennett, of the same town, the builder.

The ceremony of laying the foundation-stones of the new workhouse infirmary at Warrington was performed on Friday. The new infirmary is in close proximity to the workhouse. The contractor is Mr. Davenport, of Stockton Heath, and the architect Mr. William Owen.

An inquiry was opened on Friday before Mr. Dawson, Government Inspector, at the Board-room, Union Workhouse, in Thirsk, concerning the surcharge of £310 3s. 1d. to the surveyor of the Thirsk District Council. Mr. Combie, of York, appeared both for James Wright (the surveyor to the council) and also for the Wright family, consisting of three brothers, trading under the name, as contractors, of Wright Bros., of Thirsk, who had entered into various contracts with the Council of the Thirsk Rural District Board, for leading, &c., in the district. The real point at issue was as to the existence of such a firm as Wright Brothers, of Thirsk, and it appeared that at the last June audit the auditor had disallowed the above sum for various reasons, one of the principal being that the firm of Wright Brothers did not exist, and if it did they had their carts and horses on the surveyor's (their father's) premises.

The length of new railroad constructed in the United States last year was 1,364 miles, as compared with 1,848 miles in 1896, 1,803 miles in 1895, 1,949 miles in 1894, 2,635 miles in 1893, 4,192 miles in 1892, 4,281 miles in 1891, 5,670 miles in 1890, 5,230 miles in 1889, and 7,106 miles in 1888. The length of railroad in operation in the United States at the close of last year was 184,464 miles. The greatest length of line was built last year in the state of California, where 210 miles of railway was added to the mileage, Louisiana coming next with 145 miles.

Mr. Herbert H. Law, an inspector under the Local Government Board, held an inquiry at the Sunderland Town Hall on Friday into the petition presented by the corporation to that body for a provisional order to empower the corporation to acquire compulsorily lands for widening High-street, West; and, further, to borrow £2,020 for electric-lighting purposes.

Gainsborough Urban District Council Highways Committee has decided to recommend a complete scheme for the reconstruction of Gainsborough streets at an estimated cost of £4,000 or £5,000.

The new line from Mold to Wrexham will be opened for passenger traffic early in April. By an extension of the existing Mold and Coed Talon branch as far as Wrexham the new route will give a through connection between Denbigh, Mold, and Wrexham.

A new temporary fever hospital at the workhouse at Dearnley, near Rochdale, was formally opened on Wednesday week. The hospital is a timber-framed building, covered outside with corrugated iron and lined inside with varnished match boarding, with a layer of inodorous felt between. These are two pavilions, each 80ft. by 24ft. and each meant to hold 24 beds. Messrs. Butterworth and Duncan, of Rochdale, were the architects. It was built by Messrs. E. J. and C. Keay, of Birmingham, who contracted to finish it within six weeks, and did so. Messrs. W. A. Peters and Sons, of Rochdale, undertook the foundations and the draining, and Messrs. Hewerdine and Dawson the plumbing and sanitary work.

### PARLIAMENTARY NOTES.

**THE NATIONAL GALLERY.**—Dr. Farquharson asked the First Commissioner of Works whether, on the lines of the precedent so successfully followed in the case of the South Kensington Museum, he would obtain an expert report as to the danger by fire to the National Gallery, arising from its close proximity to St. George's Barracks and other inflammable buildings. Mr. Akers-Douglas: I do not think that an expert report is necessary, or can add to the knowledge already possessed by the Office of Works. As was the case at South Kensington, the construction of the several portions of the buildings and the circumstances of their surroundings are well known to the Department, and the question of danger from fire from outside inflammable buildings has constantly engaged its attention. Adjacent property has quite recently been purchased by the Government, with a view to lessening any such danger, and a similar course will be followed as opportunities occur. The House is aware that arrangements are in progress for the removal of the southern portion of St. George's Barracks.

A cottage hospital for Accrington and district was opened on Monday by the mayor. The hospital has cost over £7,000, and will accommodate 18 patients.

Mr. J. Bryn Roberts, M.P., formally opened on Tuesday the new board schools at Bronyfoel, near Llandwrog, Carnarvonshire. The schools have been built from the designs of Mr. R. Ll. Jones, Carnarvon, and are situate at a high altitude among the Cambrian group of mountains.

The number of men employed in the building trades at Monteith, N.B., exceeds all previous record. Large numbers of workmen are employed at the new railway station, which is being rapidly proceeded with. A large addition is under course of construction to the public school. Semidetached cottages are being erected in Panmure-street, Ramsay-street, Albert-street, and Maule-street.

The temporary building in which the congregation of Whitefield's Tabernacle, Tottenham Court-road, have been meeting has been sold, and the site will be cleared in a few days for the erection of a permanent structure on the same spot. A few years ago the old structure had to be taken down because it was insecure. The new edifice has been designed by Mr. Rowland Plumbs, F.R.I.B.A., and will be built by Messrs. Kingleres, of Oxford, whose tender for £11,000 has recently been accepted by the church. Other expenses will raise the total cost to nearly £12,000.

The demolition of the old infirmary buildings at Halifax has been commenced this week. The first portion of the infirmary was erected in the years 1836-38 at a cost of £2,400, the building being opened in the latter year. Since that time wings have been added, and in 1877, owing to increasing requirements, the assembly rooms were acquired. Now the whole of the erections have to come down to make room for the new police offices and court-house which are to be erected there. All last week Messrs. Newsome, of Sowerby, were busy removing the woodwork and plumbing fittings, and this week the shell of the building is being tackled by Messrs. J. Charnock and Sons, who have erected a steam-crane.

The Bishop of Rochester has reopened and dedicated St. Mary Magdalene Church, Southwark, after restoration at a cost of £3,700. The old barn-like appearance has gone; the decayed and dangerous plaster ceiling has been covered with an inner wooden roof of fine proportions; a new organ has been built by Messrs. Hele; the case, of solid oak, is in harmony with the Gothic lines of the church. The windows (all new except one), are of cathedral glass. The new west window, which pierces a formerly blank wall, in three lights, is filled with painted glass. A new porch being built enables the long-closed west door to be opened as the principal entrance for the future. Ugly, uncomfortable pews have given place to pitch-pine open benches. The raised chancel enables the people to see and hear.

"A Plea for an Archaeological Map of Warwickshire" was the title of a paper read before the Archaeological section of the Midland Institute, at Birmingham on Friday night, by the Rev. J. O. Bevan, who has taken part in the compilation of a work based on an exhaustive archaeological survey of Herefordshire. The Society of Antiquarians is urging the systematisation of information of archaeological interest throughout all the counties of England and Wales, and the work accomplished in Herefordshire shows how usefully researches in this direction may be crystallised in maps. The paper was followed by lantern pictures, illustrating old Warwickshire. Mr. Bevan expressed a hope that means would be taken to initiate practical steps for compiling an archaeological map of Warwickshire. Mr. W. J. Churchill gave an assurance that the question should be brought before the committee of the Architectural section.



CONTENTS.

Discovering Talent in Art .....	295
Model Specifications.—II. ....	295
The Architectural Association .....	297
Electric Lighting Notes for Architects.—XVIII. ....	298
Cement Mixtures .....	299
Charterhouse Square .....	300
Dangerous Floors .....	301
The Outlay on Brook Hospital .....	301
Iron Uprights .....	302
Books Received .....	302
Obituary .....	303
Professional and Trade Societies .....	303
Building Intelligence .....	304
Parliamentary Notes .....	304
The BUILDING NEWS Directory .....	xi.
Our Illustrations .....	305
Competitions .....	305
Correspondence .....	324
Intercommunication .....	324
Water Supply and Sanitary Matters .....	324
Legal Intelligence .....	325
Our Office Table .....	325
Meetings for the Ensuing Week .....	326
Trade News .....	326
List of Competitions Open .....	327
List of Tenders Open .....	327
Latest Prices .....	329
Tenders .....	330

ILLUSTRATIONS.

- SIENA CATHEDRAL, WEST FRONT.—MARLBOROUGH HOTEL,
- BURY STREET, ST. JAMES'S.—SHANKHILL ROAD MISSION
- BUILDING, BELFAST.—"NEWDIGATE PLACE," SURREY.—
- HISTORIC ORNAMENT.—THE DINING HALL AT THE
- CHARTERHOUSE.

Our Illustrations.

THE FACADE, SIENA CATHEDRAL.

HAWTHORNE, in writing of this very magnificent and world-famed building, says, "The cathedral is a religion in itself; how much pride, love, and reverence in the lapse of years must have clung to all this sculpture!" To this artistically-expressed idea, Mr. Wallace Rimington, the author of the accompanying equally charming study of the facade, has written the following note:—"At first one feels that there is perhaps an over-delicacy in the white marble churches of Italy; but the better you know them the more you realise their elaborate detail lends itself to such a subtle play of reflected light that the beauty of their shell-like opalescence compensates for the absence of the nobler proportions and greater picturesqueness of the cathedrals of the North." We gave an illustration of this interesting cathedral, with further particulars, on Sept. 6, 1889.

MARLBOROUGH HOTEL, BURY STREET, ST. JAMES'S.

This hotel, now in course of erection on the corner site formerly known as Ramsay's Hotel, and to which has been added No. 12, Bury-street, and Nos. 12 and 14, Ryder-street, is being carried out in accordance with the designs and under the superintendence of Mr. G. D. Martin, architect, 3, Pall Mall East, S.W., and will consist of seven floors. The basement has been planned for kitchens and the offices of the management, and there will also be a well-lighted billiard-room and gentlemen's lavatory. The ground floor will consist of a large dining-room, vestibule, entrance-hall, reception-room, bureau, and cloak-room, together with staircase and hydraulic elevator. The five upper floors will contain ladies' and general drawing-rooms, and about 60 bed and sitting rooms. There will be ample bath and lavatory accommodation on each floor. The elevation, which is of Renaissance style treated in a free manner, will be executed in red brick with Monk's Park stone dressings. The whole of the floors, partitions, and roof will be of fireproof construction.

SHANKHILL ROAD MISSION BUILDINGS, BELFAST.

This block of buildings, of which the foundation-stones were laid on Oct. 23rd, has a frontage of 92ft. and a depth of 135ft. free from ancient-light restrictions on every side. In designing the building it was sought to avoid the long corridors, so universal in buildings of this description, by contriving a central octagonal hall with galleries round and large dome light. This hall will give access to all the departments of the building which radiate from it. The building is divided into seven principal departments. The first of these is a large hall capable of seating about 2,000 people, designed in the form of an amphitheatre with a single gallery. This hall will have entrances and exits from the Shankhill-road, and also from Carlow-street, will be well lighted, and

will be in all respects a hall well adapted for large social gatherings. In connection with the hall are gentlemen's, ladies', and choir committee-rooms and cloak-rooms. The second is a medical mission department, comprising a large waiting-hall, capable of seating about 200; a doctor's consulting-room, and dispensary and dressing-rooms. It is entered by the main entrance from the building, and will also have a separate entrance from Carlow-street, enabling it to be used directly from the outside. The third, or business, part of the premises will consist of four large shops—two on either side of the main entrance—and also commodious offices over these shops. The fourth is a soup-kitchen department, with ample convenience for cooking and supplying soups and other nourishing provisions for the benefit of the poor, and also giving the necessary plant for supplying large social gatherings in connection with the mission. This department can also be entered direct from the Shankhill-road. The fifth section comprises a minor hall and classrooms. This hall will be situated on the first floor, and capable of accommodating 250 people. There will also be several class and committee-rooms. The sixth is a social and recreative department. These rooms will be situated on the second floor, and will comprise general parlour, men's reading-room and library; boys' club-room and girls' guild-room; and also ladies' private sitting-room and bookstall. The seventh department is the residential training home; this will comprise four separate departments—(1) a wing with parlour and bedroom accommodation for gentlemen students, and a corresponding wing for lady students; (2) the superintendent's residence; (3) the servants' department; (4) the lecture-hall and classroom department. Altogether there will be accommodation for 20 students. Over a part of the building there will be a flat roof with staircase communication, so that it can be used as recreation ground in the summer months. The materials proposed in the construction of the building are Scrabo stone for the front elevation and part of the return, with red brick for the remainder. The roof will be covered with Westmoreland green slates for the towers and front part of the building. The N.A.P. Window Co.'s patent fittings are being adopted for principal windows. The main entrance-hall and cloakroom walls will be tiled, and granite plaster will be used on the walls in more general use. There will be fireproof floors over the greater part of the first two stories, thus making the building not only more secure, but preventing the passage of sound from one part to the other. Internal fittings have been designed in an inexpensive but substantial manner. Mr. W. J. W. Roome, M.S.A., is the architect, and Messrs. McLaughlin and Harvey are the contractors.

"NEWDIGATE PLACE."

This house is erected on an elevated site overlooking Leith Hill, with lovely views over Reigate and Horsham. The walls are faced with local red bricks, the upper part being covered with weather tiling. The roofs are tiled, the whole of the external woodwork is of oak, cut from trees grown on the estate. The entrance hall has an open oak timber roof, with a gallery round two sides, and lighted by stained-glass windows. It is panelled to a height of 10ft., with oak panelling; a carved screen separating the hall from staircase, which is also oak. The dining-room has oak panelling, with oak beams to form panelled ceiling. The drawing-room has a deal dado, painted ivory white. The billiard-room has Oregon pine framing carried up to underside of frieze. All other internal joinery is also in Oregon pine, stained and beeswaxed. The house was erected by Messrs. J. and J. Ward, of Warrington, from the designs, and under the superintendence, of Mr. J. Hatchard Smith, F.R.I.B.A., who also designed the decorations, which have been carried out by Mr. Carrick, of Reigate.

HISTORIC ORNAMENT.

This plate represents a series of capital drawings illustrative of historic design, and with each object their author, Mr. John J. Brownword, has written an accompanying account, so that no further description by way of letterpress seems necessary. The sheet forms part of a series for which a National Silver Medal was given to Mr. Brownword last summer.

CHARTERHOUSE SQUARE.

(See descriptive article on p. 300.)

COMPETITIONS.

DORKING.—The workhouse infirmary committee of the Dorking Board of Guardians have reported that Mr. James Edmeston, the assessor appointed by the board, had awarded the prizes in the competition for the best plans for the proposed new infirmary as follows:—1st, Mr. H. Percy Adams, 28, Woburn-place, Russell-square; London; 2nd, Mr. J. H. Cossar, Stamford; 3rd, Mr. Clarence Coggin, 15, York-buildings, Adelphi. The committee also reported that a letter had been received from Mr. Edmeston, stating that he was not sure that any of the designs submitted could be fully carried out for £4,000, and suggesting that the architect should be asked to furnish a guaranteed tender from some substantial builder. Thirty-nine competitive designs were sent in. The drawings have been on view this week.

RHONDDA VALLEY, GLAMORGANSHIRE.—At the last meeting of the Rhondda District Council, a committee brought up their report and their award on the plans sent in for competition for an isolation hospital to be erected by the council at Ystrad, and recommended the plan numbered 6. This report was adopted, and the successful competitor was Mr. W. D. Morgan, architect, of Ton Pentre, Rhondda Valley. Accommodation is to be provided for 32 patients, matron, nurses, and non-resident medical officer, with laundry, disinfecting and discharging blocks, &c. The cost of the proposed scheme is estimated at about £10,000. Ten sets of designs were received.

CHIPS.

A new chapel has been erected at Chesham, and special attention has been paid to the ventilation, which is carried out on the Boyle system.

Mr. Solomon J. Solomon, A.R.A., is engaged in painting a picture depicting the Lord Mayor and Sheriffs awaiting at Temple Bar the arrival of the Queen on Jubilee Day.

A Primitive Methodist chapel in Moor-street, Brierly Hill, was opened on Monday. The front of the edifice is Renaissance in style, and is of brickwork, with terracotta ornamentation. The church has an open roof, the principals being filled in with carved and pierced work and shaped spandrels. The pewing and framing are of pitch-pine, and polished walnut is used for the rostrum. The chapel is heated by hot water. A raised gallery is provided for choir. Messrs. Hicklon and Farmer, of Walsall, are the architects, and the work is being carried out by Mr. Horton, contractor, of Brierly Hill. The total cost has been £1,500.

The death at an early age from consumption is reported from Canada of Mr. D. G. Baxter, of Stratford, Ont., one of the best known and most talented of the younger architects of the province. He was the first architectural student to pass the examinations of the Ontario Association of Architects.

At Ipswich, on Tuesday in last week, the foundation-stone was laid of a building to be erected in accordance with the will of the late Mr. R. C. Rapier, to serve as a rest for the workmen at the Waterside Iron Works of Messrs. Ransomes and Rapier. The site is close to the entrance gates, and the building will have a frontage of 80ft. There will be a coffee-room, a reading-room, and lavatory accommodation. Mr. Fred. Bennett, of St. Clement's Works, Ipswich, is the builder.

Colonel Durnford held an inquiry at Llandudno on Friday, on behalf of the Local Government Board, respecting applications by the urban district council for sanction to borrow £8,634 for the works of water supply, £3,583 for gasworks purposes, and £1,394 for the purchase of land as a site for workmen's dwellings.

The Conservative club at Oswestry was reopened on Feb. 24th after the addition of a wing. The improvements consist of a new billiard-room, bar, lavatories, and alterations to the hall and card-room. The general contract was let to Mr. William Felton, Oswestry, the seating and decorating being executed by Messrs. J. Jones and Son, also of Oswestry. The work has been carried out from the designs and under the superintendence of Messrs. Shaylor and Madoc-Jones, architects, Oswestry. Mr. E. M. Gardner fitted the heating apparatus.

Extensive building operations are going on at the Lower Brewery, Stone-street, Maidstone, in connection with the erection of new premises and plant, and on Wednesday week the foundation-stone of the new brewery was formally laid. The builder's work is being executed by Messrs. Wallis and Sons, of Maidstone; the ironwork by Messrs. Eastwood, Swingles, and Co., Limited, of Derby; the coppersmith's work by Mr. R. Dann, of Maidstone; and the slate backwork by Mr. J. Dean, of the Central Buildings, North John-street, Liverpool.

# THE CHARTERHOUSE

## The Dining Hall

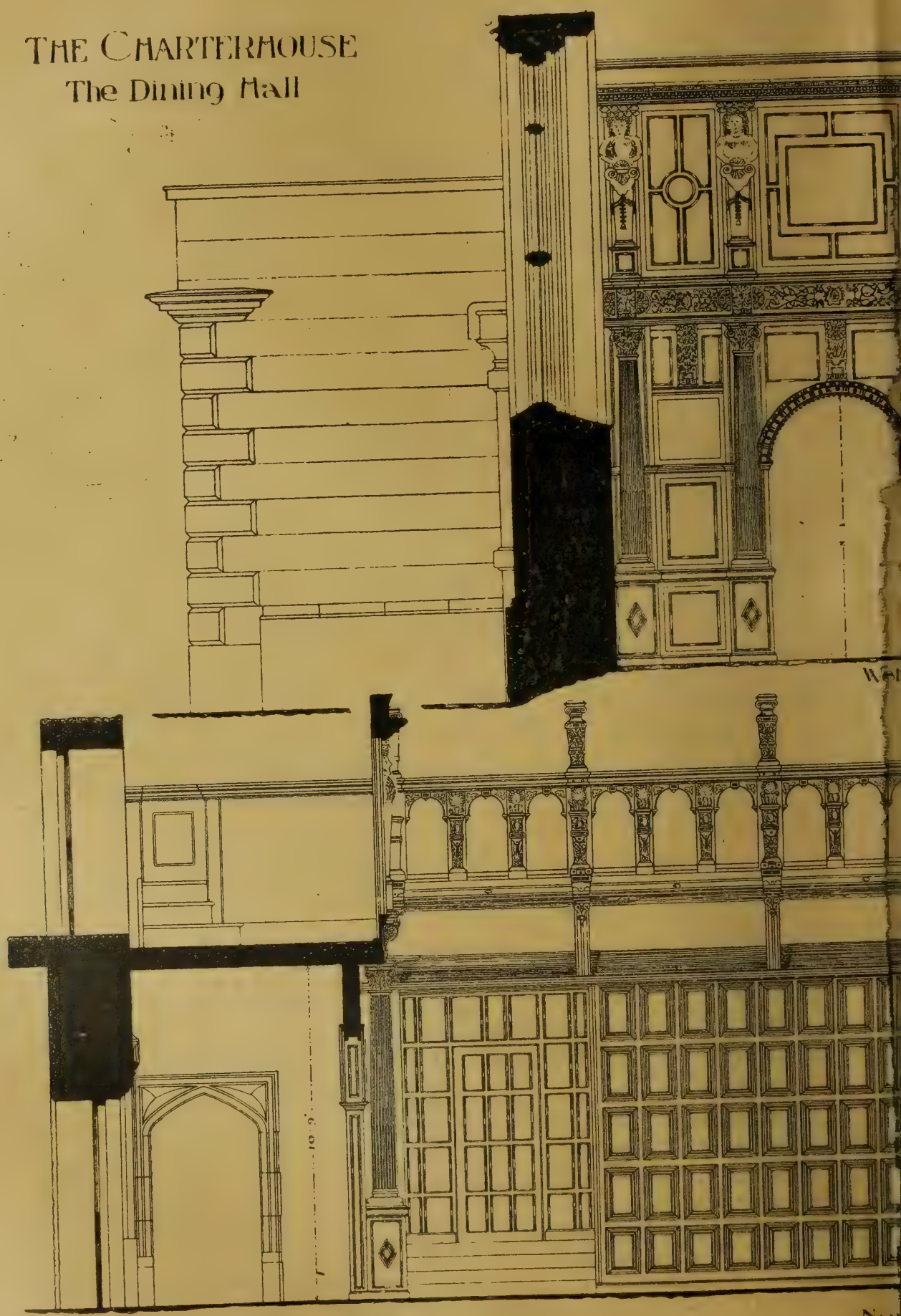

W. H.

Z. C.

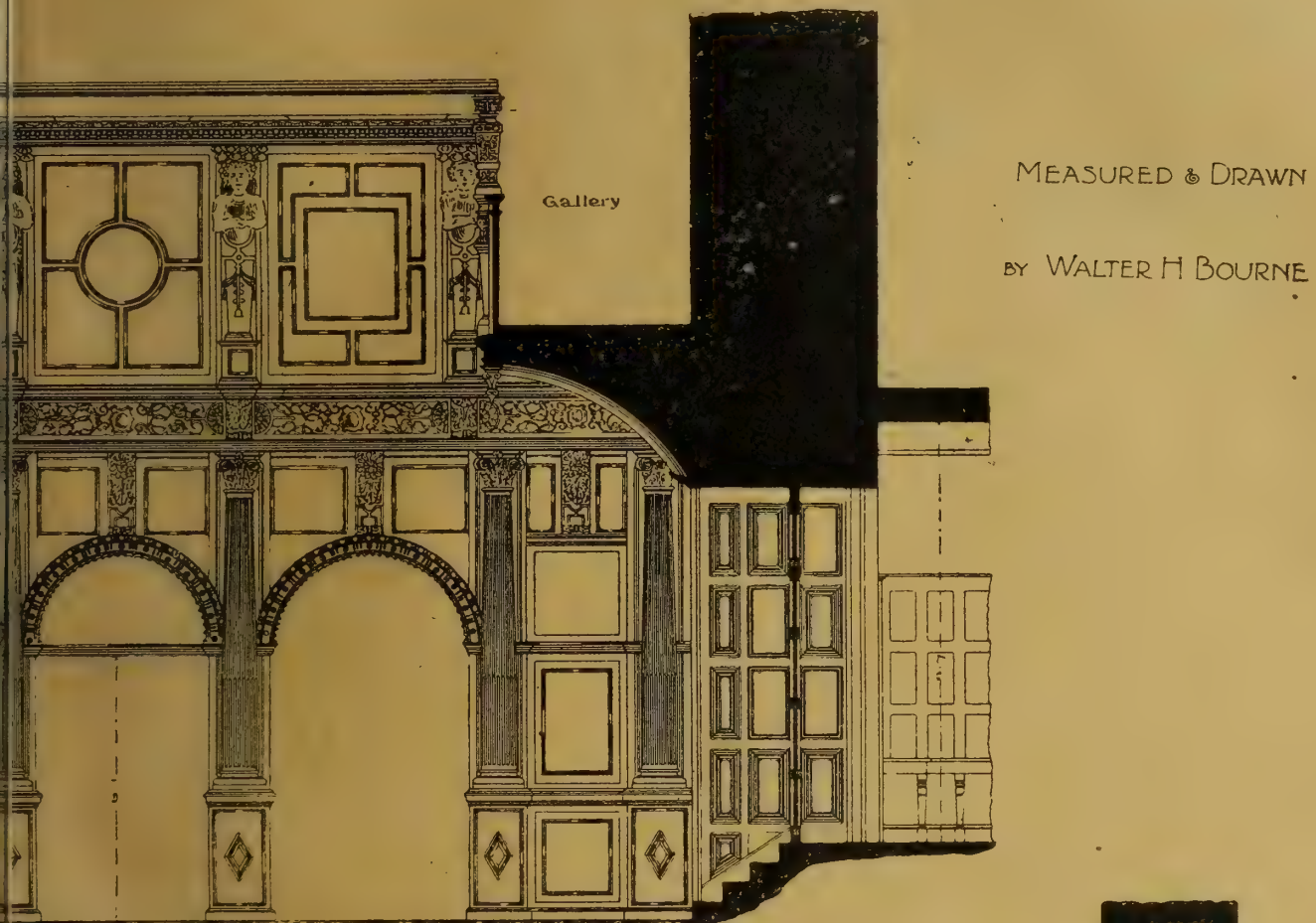

MEASURED & DRAWN

BY WALTER H BOURNE

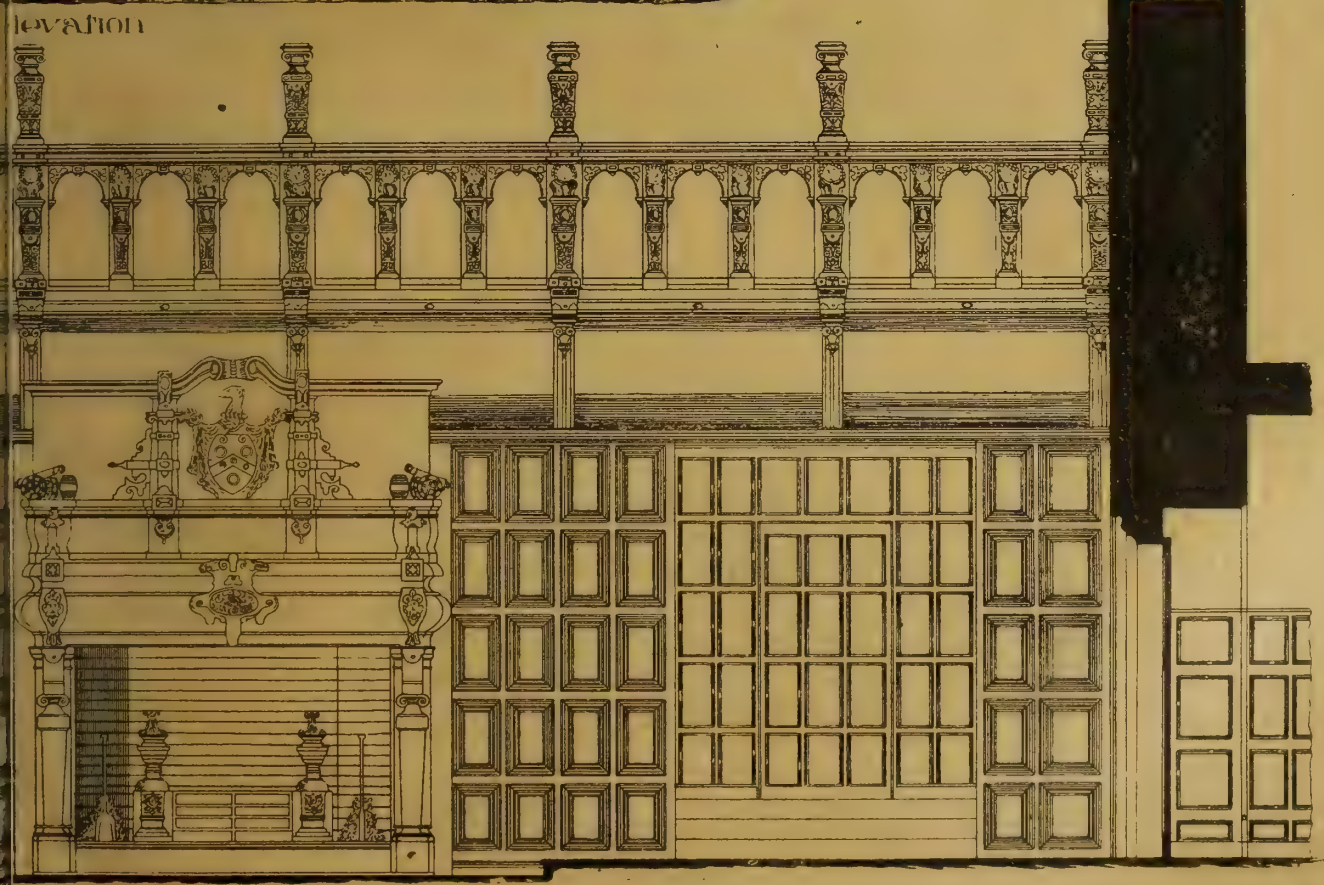

Elevation

## TO CORRESPONDENTS.

[We do not hold ourselves responsible for the opinions of our correspondents. All communications should be drawn up as briefly as possible, as there are many claimants upon the space allotted to correspondents.]

It is particularly requested that all drawings and all communications respecting illustrations or literary matter should be addressed to the EDITOR of the BUILDING NEWS, 332, Strand, W.C., and not to members of the staff by name. Delay is not unfrequently otherwise caused. All drawings and other communications are sent at contributors' risks, and the Editor will not undertake to pay for, or be liable for, unsought contributions.

Cheques and Post-office Orders to be made payable to THE STRAND NEWSPAPER COMPANY, LIMITED.

## TERMS OF SUBSCRIPTION.

One Pound per annum (post free) to any part of the United Kingdom; for Canada, Nova Scotia, and the United States, £1 6s. 0d. (or 6dols. 90c. gold). To France or Belgium, £1 6s. 0d. (or 3fr. 90c.). To India, £1 6s. 0d. To any of the Australian Colonies or New Zealand, to the Cape, the West Indies, or Natal, £1 6s. 0d.

## ADVERTISING CHARGES.

The charge for Competition and Contract Advertisements, Public Companies, and all official advertisements is 1s. per line of Eight words, the first line counting as two, the minimum charge being 5s. for four lines.

The charge for Auctions, Land Sales, and Miscellaneous and Trade Advertisements (except Situation advertisements) is 6d. per line of Eight words (the first line counting as two), the minimum charge being 4s. 6d. for 40 words. Special terms for series of more than six insertions can be ascertained on application to the Publisher.

Front-page Advertisements 2s. per line, and Paragraph Advertisements 1s. per line. No Front-page or Paragraph Advertisement inserted for less than 6s.

Advertisements for the current week must reach the office not later than 3 p.m. on Thursday. Front-page Advertisements and alterations in serial advertisements must reach the office by Tuesday morning to secure insertion.

## SITUATIONS.

The charge for advertisements for "Situations Vacant" or "Situations Wanted" is ONE SHILLING FOR TWENTY-FOUR WORDS, and Sixpence for every eight words after. All Situation Advertisements must be prepaid.

## NOTICE.

Bound copies of Vol. LXXII. are now ready, and should be ordered early (price Twelve Shillings each), as only a limited number are done up. A few bound volumes of Vols. XXXIX., XL., XLI., XLVI., XLIX., LI., LIII., LVIII., LIX., LXI., LXII., LXIII., LXIV., LXV., LXVI., LXVII., LXVIII., LXIX., LXX., LXXI., LXXII. may still be had, price Twelve Shillings; all the other bound volumes are out of print. Most of the back numbers of former volumes are, however, to be had singly. Subscribers requiring any back numbers to complete volume just ended should order at once, as many of them soon run out of print.

R. C. WHITELEGGE. (No.)

RECEIVED.—F. N. D.—S. T. M.—O. S. and Co.—S. D. T.—N. C. and Son.

## Correspondence.

## THE GOLD MEDAL AT THE INSTITUTE.

To the Editor of the BUILDING NEWS.

SIR,—To read the remarks addressed to you by Mr. Woodward, and also the letter which you have printed on this subject from the pen of "An Art Worker," it might be thought, if we did not know better, that the so-called "snuggery" of a Council at Conduit-street was a self-elected body, whereas they are the elect of the voting open to all members of the Institute; and, moreover, I beg leave to assert, this self-made somewhat scandalised Council contains a few, at any rate, of the most capable men in the ranks of the architectural profession. There are, I daresay, a few wire-pullers there, and one or two who have just managed to pass muster in order to further individual ends; but whatever their failings, it is of no use ignoring the fact that the votes of the members have put these gentlemen into office. Of course, everybody is aware that nothing more than a very luke-warm interest is taken in these elections, only a comparatively small proportion of the electorate taking the trouble to vote at all. Architectural politics for the time seem moribund. Now and then some enthusiastic reformer obtains an admission to this estimable board; but his vitality is speedily absorbed by the sterilising conservatism which always seems to dominate the proceedings of the Institute Council; or possibly, at last, he gives up his endeavours in despair, particularly as he realises how unwelcome such aims are, how much time he has to devote in furthering them, and how unlikely, if persisted in, they are to develop

chances for personal advancement. The giving of the Gold Medal, after all, to Mr. Aitchison by the Council can do the recipient no harm, and possibly but little good. If mutual satisfaction is secured thereby, why make all this pother? The recipient's old friend, Wm. Burges, used to say it ought to be shot for. Ruskin declined it, and Mr. Butterfield, though he allowed the medal to be accorded him, would not come to receive it. The honour is not an unprecedented one, and who can tell the internal difficulties which beset the Council? It is not in the least likely that they will condescend to take any notice of critical communications in the newspapers, anonymous or otherwise;—why on earth should they? All the same, it does appear a pity that the Council should remain, for all practical purposes, so incapable of dealing with unprofessional conduct on the part of its members—men who care nothing who sinks so long as they swim. Anything like decided action by the Council in such matters is never heard of—at any rate, not since the Metropolitan Board of Works days. The cases requiring such drastic measures as expulsion no doubt are happily rare; but still it cannot be denied that scandals are not unknown. I do not refer, of course, to the non-payment of subscriptions; naturally enough, men are struck off the list for that. Why is it that the Council of the Royal Institute of British Architects is not a real influence in the profession and in the art world? Never mind, my masters, about the Gold Medal.—I am, &c.,

FUNCTUS OFFICIO.

## Intercommunication.

## QUESTIONS.

[11909].—**Silicate Cotton.**—I have lately used silicate cotton in sheets 2in. to 3in. thick, laid on boards between the joists of a floor over a drawing-room, for the purpose of sound-proofing such floor. In one case where I used this material the result was quite satisfactory; but in a recent case, where the walls supporting the joist-ends are cavity walls, the silicate cotton has not been of any use in sound-proofing the floor; in fact, the noise of traffic on this floor is more distinctly audible than in any



other part of the building where the floors are not sound-proofed. If any of your numerous subscribers have had a like experience with the use of this material, I shall be glad if they will, through your columns, say what means they used to remedy the defect?—W. H., Manchester.

[11910].—**Painting Corrugated Iron.**—I want a ruby-red paint to put on a corrugated iron roof, so that it may be made to look as if tiled with red tiles. Some eight years ago I got from a Hull firm a ready-mixed paint which was very good in every way and kept its colour splendidly. On asking this firm to repeat the order, they sent me Indian red, which is as near the colour I require as the two poles to each other. When I returned it they said they couldn't carry out the order. Red lead and orange lead are of no use, for they turn black in a very short time. I want a very bright ruby-red that will keep its colour. Is it an oxide that should be used? I shall be truly grateful if any of your readers can help me.—JAMES COOPER, Cayton, Scarborough.

## REPLIES.

[11908].—**House Drainage.**—"Domus" had better place an inspection-chamber at the foot of soil-pipe, and another turning chamber at the corner where the soil-pipe drain turns the corner of the house. The sink can be made to enter this chamber. Then the side main drain should be made to run straight to the disconnecting manhole near the front sewer. A good form of disconnecting trap is the "Improved Kenon," which is inserted in the outgo side of manhole, and has a cleaning arm and plug over. The chamber may be about 3ft. square. The separate r.w. branches should run into the straight drain where necessary. "Domus" is right as to this drain. The manholes should be ventilated, if possible—at least, the disconnecting one near sewer. Send for Crapper and Co.'s or Doulton's lists of gully-traps.—G. H.

[11907].—**Jointing Drain-Pipes.**—If the drain is for a house, and the ground is firm and not clayey, I should recommend neat cement, or cement and sand in the proportion of 1 of cement to 2 or 3 of clean, sharp sand. If the soil is yielding, Doulton's or Stanford's joints are recommended. The cost of the latter is trifling.—G. H.

The general asylums committee of the West Riding County Council have purchased a site of over 200 acres at Ackworth, as a site for a fourth pauper lunatic asylum. The cost of the land is about £46,000, and the building itself is expected to cost between £450,000 and £500,000.

## WATER SUPPLY AND SANITARY MATTERS.

**THE METROPOLITAN WATER SUPPLY.**—At Monday's sitting of the Royal Commission on this subject, Mr. W. H. Dickinson, chairman of the Water Committee of the London County Council, was examined. He said that since 1891 the policy of the Council with regard to the water question had strictly followed the recommendations of Sir M. W. Ridley's committee. In his opinion, in order to arrive at the true value of the undertakings of the companies, there were problems to be solved which were beyond the province of any ordinary administrator, and an arbitrator should be appointed with special powers. He justified the arbitration clause in the Purchase Bill introduced by the County Council, and said the Council had always been of opinion that the result of ordinary arbitration under the Lands Clauses Act would be to give the water companies a present of six or seven millions of money. The witness gave a detailed account of the action and attitude of the County Council on the whole question of the London water supply.

**THE WATER SUPPLY OF SOUTH STAFFORDSHIRE.**—Barr Beacon, one of the most prominent landmarks in the Birmingham district, has been selected by the South Staffordshire Waterworks Company as a site for a distributing reservoir. Near Bourne's Pool, the company during the last three or four years have sunk wells, and found a good supply. This water they propose to pump to the top of Barr Beacon. The reservoir is the third which the company have found it necessary to construct lately, in consequence of the increasing population. The South Staffordshire Company's district embraces portions of the counties of Stafford, Derby, Warwick, and Worcester, its extremes reaching from within about three miles from Derby to about eight miles from Kidderminster, a distance of over 40 miles. Its greatest width is 20 miles, and its area is 276 miles—the largest area supplied by any water undertaking in this country, comprising 43 towns and parishes. The population of the whole area is about 566,000, and the company supplies 94,853 houses, or an estimated population of 474,265. The maximum quantity of water supplied per day approaches 12½ million gallons, and the total for the year 1896 was 3,206 million gallons, of which 871 million were for trade use. The new works, which are being carried out under the direction of the company's engineer (Mr. H. Ashton Hill, M.Inst.C.E.), will bring the number of reservoirs owned by the company to sixteen. The storage reservoir now in course of construction will supply, among other places, West Bromwich and Walsall. The works on Barr Beacon were commenced in May last year, and will be finished before the spring of 1899. The top level of the reservoir will be 744ft. above ordnance datum. The company have acquired seven acres of land, and the reservoir will occupy about three-fourths of this area. Built with sides sloping internally, the reservoir will measure at its margin 410ft. by 310ft., and at the bottom 350ft. by 200ft., the depth being 21ft. Its storage capacity will be upwards of ten million gallons. The soil in which the reservoir is being made is gravel drift. Clay is plentiful, however, in the immediate neighbourhood, and this will be utilised for puddling the sides and bottom, consisting of 18in. of clay, 9in. of concrete, and 3in. of blue-brick masonry. The clump of trees, by which the hill is recognised far and near, will be outside the boundary, and will not be interfered with. The early British earthworks which are still to be traced on the hillside will not be disturbed. A novel method of excavation has been adopted by the contractors for this portion of the work, Messrs. R. and B. Bomford, of Pitchill. The ground has been first loosened by steam cultivators. Following upon these, an apparatus has been used, the essential part of which is a large scoop, which will hold 30cwt. of soil. This scoop is attached to a wire rope, and is dragged through the soil by a portable winding-engine, as in steam-ploughing. Attached to it is a small car, in which the attendant rides, and gearing is provided by means of which the scoop, when it has been filled and has reached the tipping place, can be overturned. Another change of the gearing sets the scoop clear of the ground for the return journey. By means of these scoops 12 men have been able to do the work of 200 navvies. This is the first instance of the complete application of this method, and it has been developed under the direction of Mr. Evershed, Messrs. Bomford's representative. The contractor for the reservoir is Mr. George Law. The other two reservoirs have been completed. One is at Shire Oak Hill, near Brownhills, and was finished about 12 months ago. It has a capacity of 4½ million gallons, and its top level is 593ft. above ordnance data. The other is at Springsmire, near Dudley, and has a capacity of 3½ millions. These two reservoirs have vertical sides and concrete walls, lined with brickwork.

Mr. James Saunders, A.R.I.B.A., assistant borough surveyor of Oldham, has been elected city surveyor of Chichester.

17  
18  
19

— 2 —

NEWDIGATE PLACE · SURREY · J. HATCHARD · SMITH FRIBA ARCHT

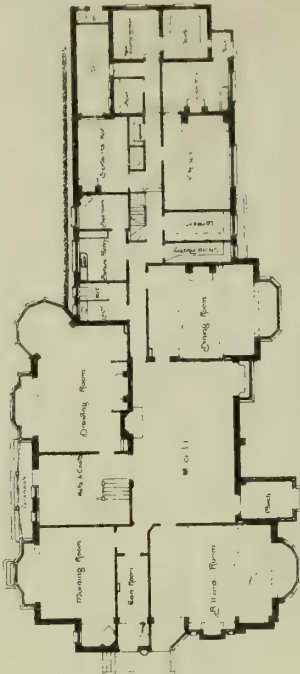

Ground Floor Plan

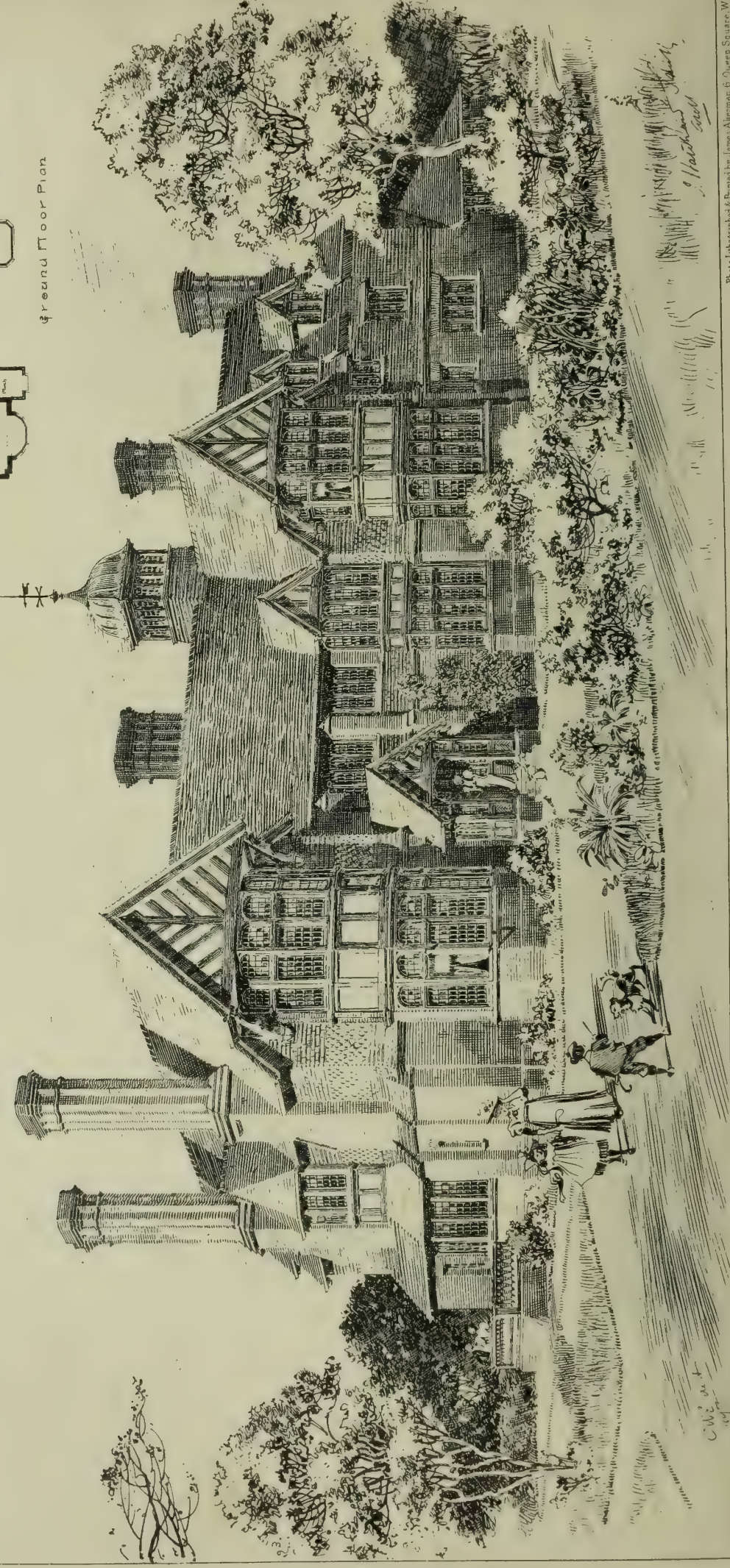

*J. Hatchard Smith*

THE BUILDING PEWS, MAR. 4, 1898.

MARLBOROUGH · HOTEL ·  
 BURY · STREET · ST. JAMES'S · S. ·  
 G. D. MARTIN ARCHITECT. ·  
 NO 3 PALL MALL EAST, S.W.

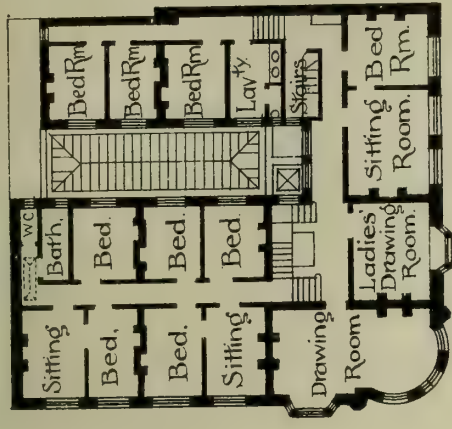
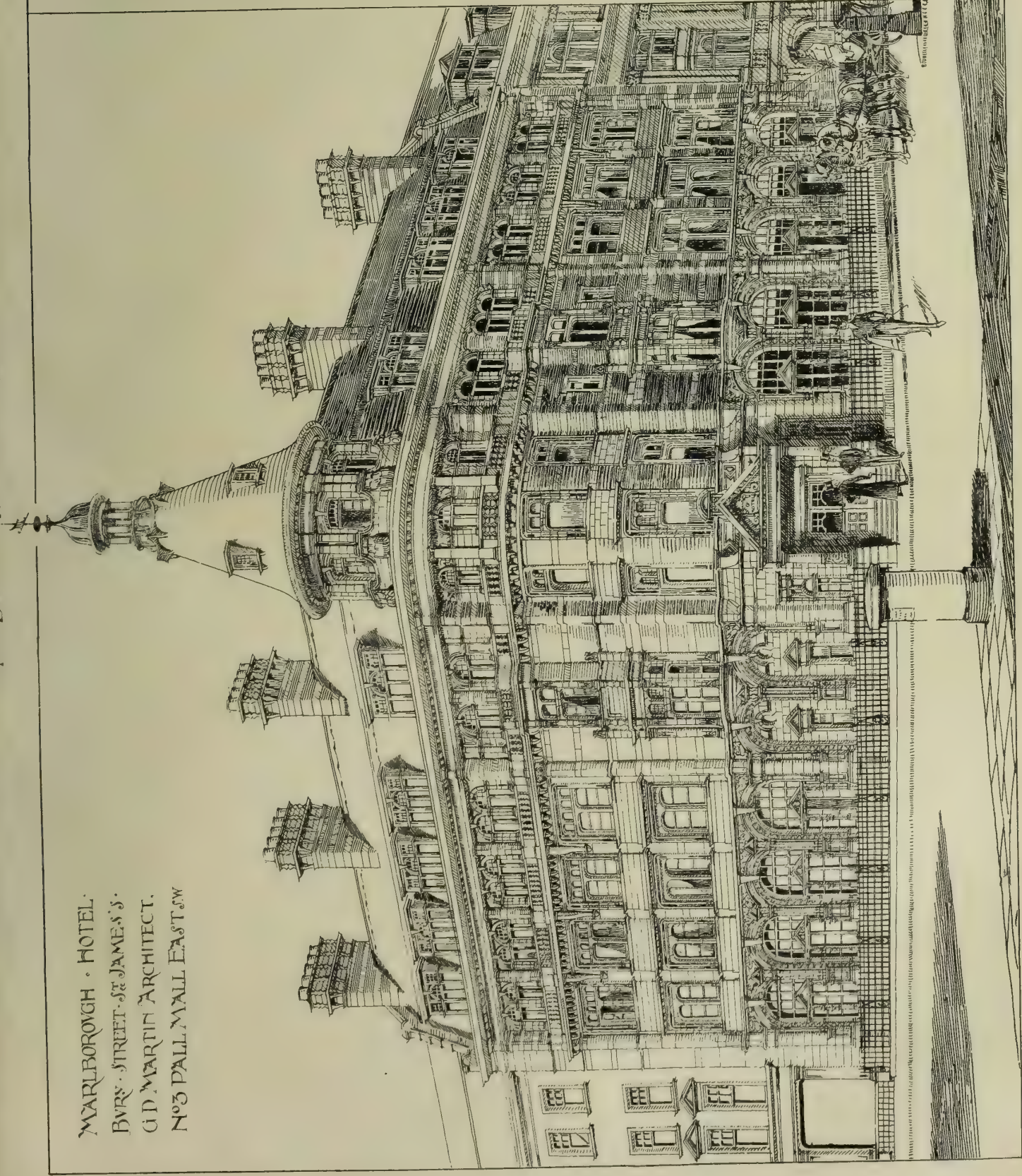

1st Floor plan.

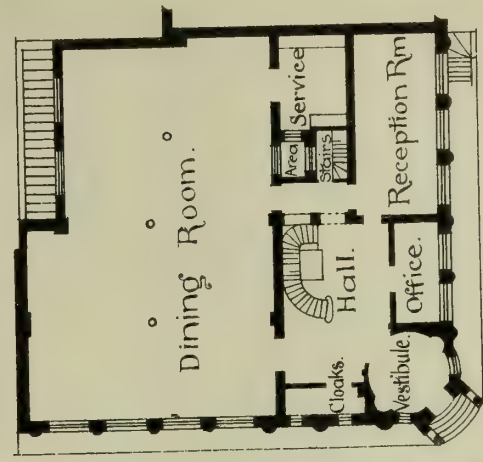

Ground Plan.

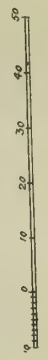

Photo Lithographed & Printed by James Alliman, 6 Queen Square, W. C.











From the same source as the figure of the female figure, which is a personification of the virtue of modesty, and is a personification of the virtue of modesty, and is a personification of the virtue of modesty.

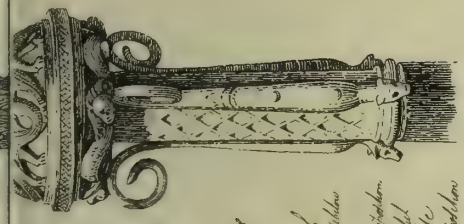

From the same source as the figure of the female figure, which is a personification of the virtue of modesty, and is a personification of the virtue of modesty, and is a personification of the virtue of modesty.

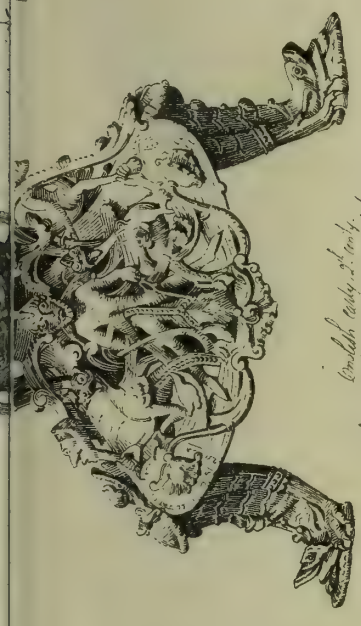

From the same source as the figure of the female figure, which is a personification of the virtue of modesty, and is a personification of the virtue of modesty, and is a personification of the virtue of modesty.



From the same source as the figure of the female figure, which is a personification of the virtue of modesty, and is a personification of the virtue of modesty, and is a personification of the virtue of modesty.

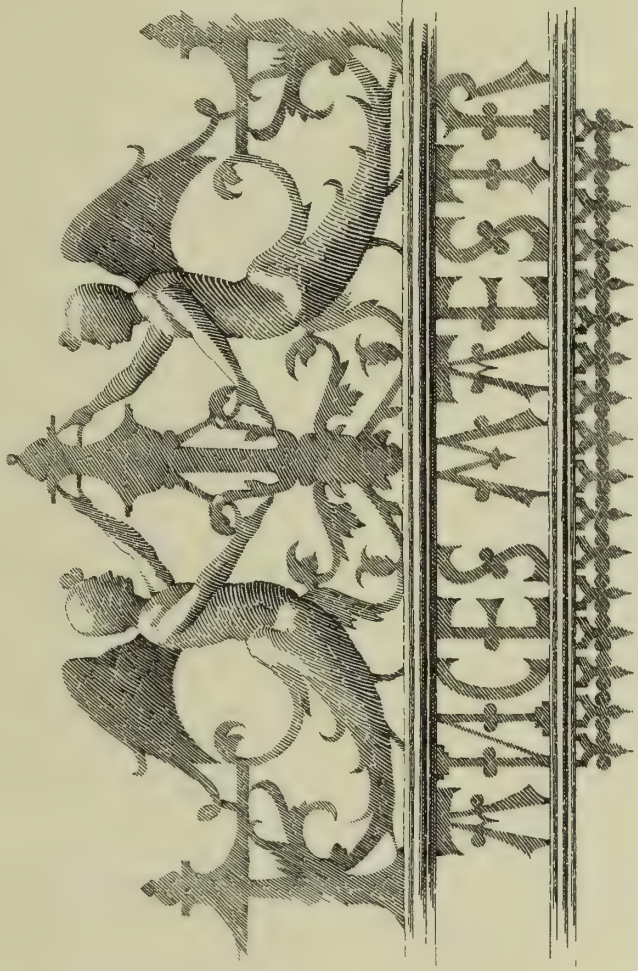

From the same source as the figure of the female figure, which is a personification of the virtue of modesty, and is a personification of the virtue of modesty, and is a personification of the virtue of modesty.

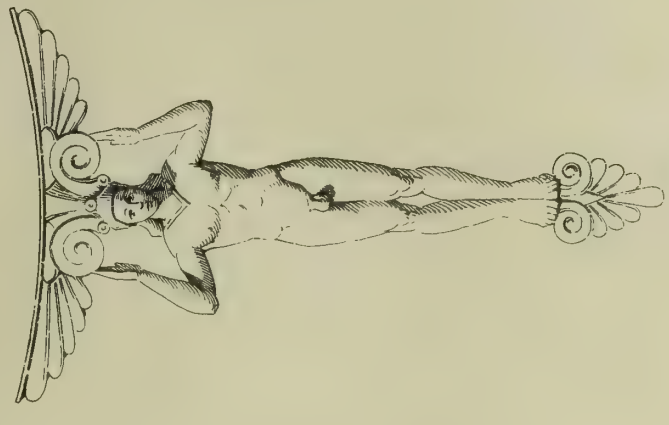

From the same source as the figure of the female figure, which is a personification of the virtue of modesty, and is a personification of the virtue of modesty, and is a personification of the virtue of modesty.







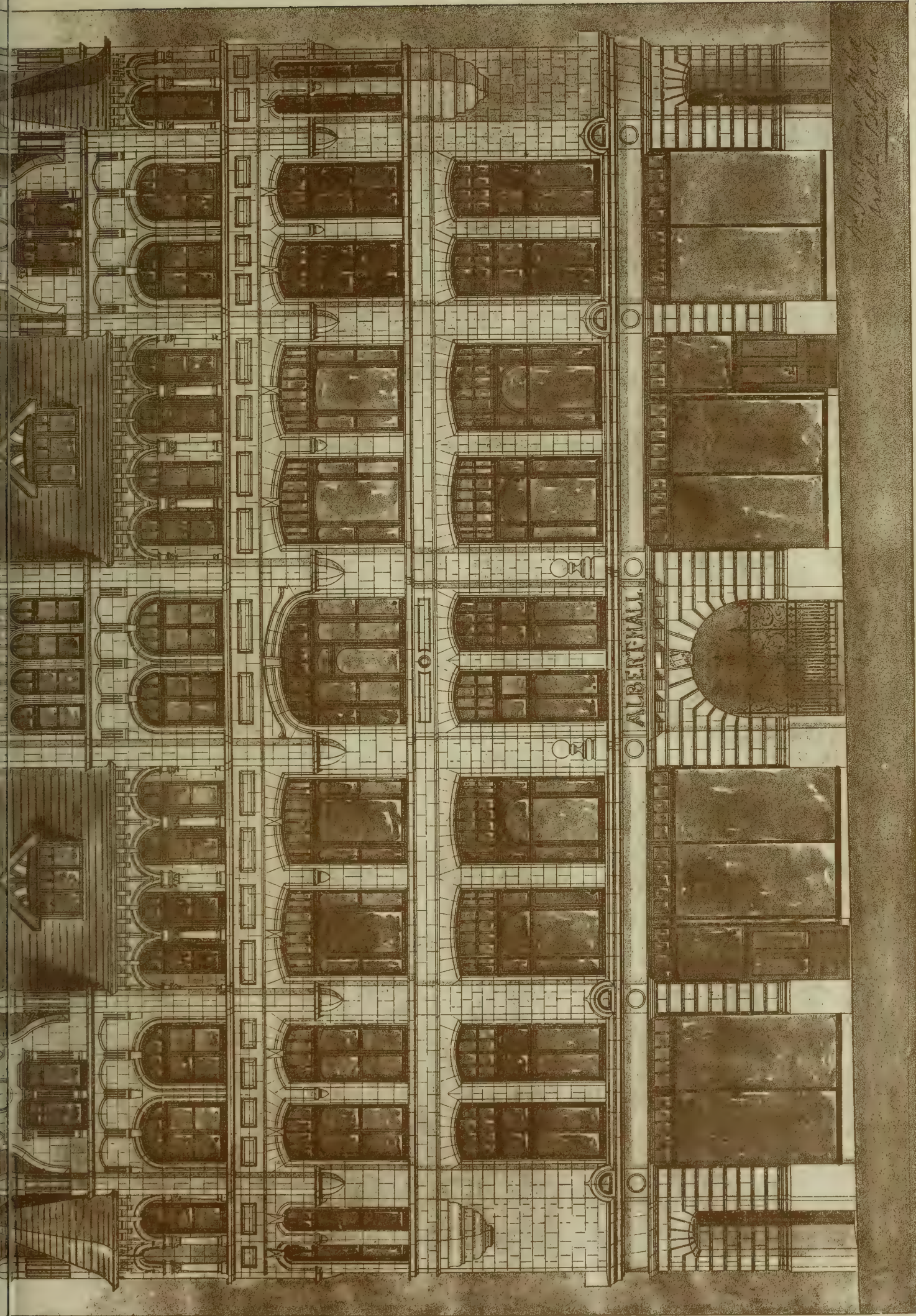

"PHOTO-TINT" by James Akerman in Queen Square, London W.1.

SHANKHILL ROAD MISSION BUILDING · BELFAST · WJW·ROOME·ARCHT

*Handwritten text, possibly a signature or date.*







THE BUILDING DEWS, MAR. 4, 1898.

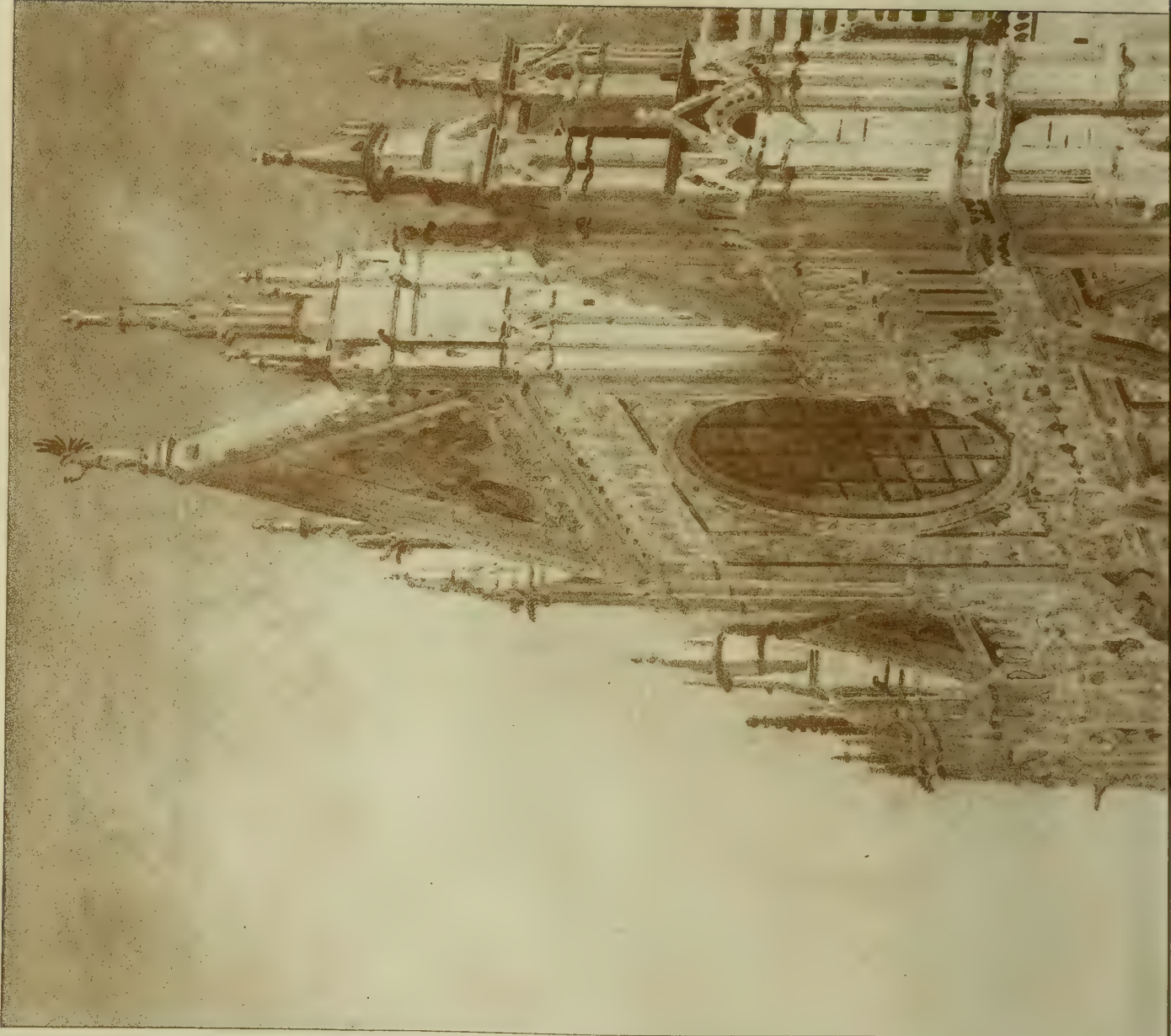

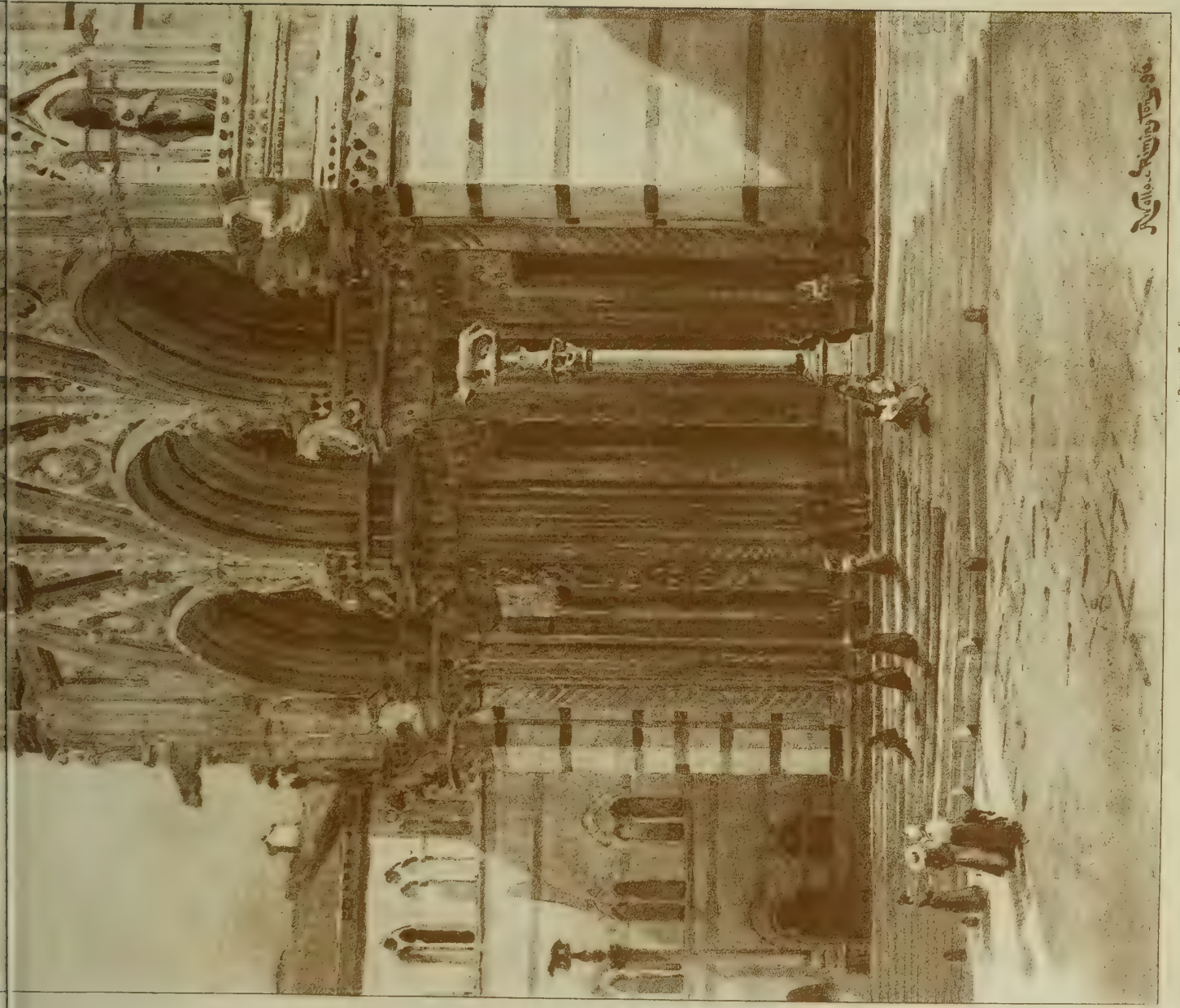

SIENA CATHEDRAL · FROM A WATER COLOUR DRAWING BY A WALLACE RIMINGTON ARPE

PHOTO-TINT BY James Agnew & Sons, Queen Square, London W. 1.

Wallace Rimington Arpe



## LEGAL INTELLIGENCE.

**THE LONDON COUNTY COUNCIL AND THE WORKS DEPARTMENT.**—The referee's award in the action between James Miller (plaintiff) and the London County Council (defendants), remitted by order of Mr. Justice Hawkins from the Queen's Bench Division to Mr. Herbert Thomas Steward, architect and surveyor, of 45, Parliament-street, was received on Friday. Litigation in the case has been pending since 1895. The plaintiff in the action is the owner of a number of small cottages in Miller's-avenue, Stoke Newington-road. At the rear of these cottages and on a much lower level was a building which had been decreed as dangerous by the County Council officials. The case for the plaintiff was that the County Council sent their workmen from the Works Department, and altogether demolished the alleged dangerous structure. In doing so they removed a portion of a wall which had hitherto held up the higher land at its back, and plaintiff's cottages were then in danger of falling down. To make the damage good the plaintiff had to build a new wall, and he called on the County Council to recompense him for the cost he had been put to. As they declined to pay, he brought an action for damages. The referee awarded the plaintiff £17 10s., and directed the defendants to pay the plaintiff his costs of the law action, including the costs of the reference and also the referee's fees and the costs of his award. The fees and the costs of the award were assessed at £65 9s. 6d. There were several counsel engaged in the case and 29 witnesses, some of whom were leading surveyors.

**PARTY-WALL NOTICES.**—At Guildhall Police-Court on Feb. 25, Messrs. Spencer and Company, of 32, Commercial-road, Lambeth, were summoned at the instance of Mr. E. Woodthorpe, M.A., district inspector for the northern part of the City, for that, on or about January 5 last, they did certain work at 45a and 46a, Basinghall-street, and 4, London Walk-avenue without giving proper notice under the Building Act, 1894. Evidence having been given to the effect that a hole had been made in a party-wall without notice being given to the district surveyor, a fine of 40s. was imposed and £2 2s. costs.

**BUILDER AND HOUSE AGENT.**—MESSRS. HOLLIDAY, PEARSON, AND CO. V. FREDERICK MOORE.—The plaintiffs, who are builders and estate agents, of 1, Queen's-parade, Streatham, brought an action in the Wandsworth County Court to recover the balance of account, £32 9s. 6d., of a verbal contract, £48 16s. 10d., of which £10 had been paid on account, &c. (this included fees to plaintiffs for obtaining house and stamping agreement). The defendant, an agent of house property in London, alleged that the works were not completed by plaintiffs. This action was part heard by his Honour on the 17th January last, who ordered it, by consent of both parties, to be referred to the court arbitrator, Mr. R. M. Hiscocks, architect and surveyor, of No. 1, Church-row, High-street, Wandsworth. The arbitrator having heard evidence, and measured the works, extras to dwelling-house, 45, Barrow-road, Streatham Common, found the value of all the work (after deducting work which had been omitted), including agents' fees, to be £30 14s., and allowed costs to plaintiffs both in the action and reference. His Honour gave judgment for plaintiffs, £30 14s., and allowed costs, in the terms of the arbitrator's award.

**LONDON SCHOOL BOARD AND THE BUILDING ACTS.**—At the Surveyors' Institution, Savoy-street, Strand, a tribunal of appeal under the London Building Act, 1894, recently sat to adjudicate upon an appeal by the London School Board against a notice of requirement served by Mr. Ellis Marsland, hon. sec. S.A., the district surveyor of Camberwell, calling upon the Board to make certain teachers' rooms 8ft. 6in. in height, instead of 7ft. 6in., as provided for in the plans of a school now being built at Leo-street, Old Kent-road. Mr. H. F. Gibson, from the solicitor's department of the London School Board, appeared in support of the appeal, and Mr. Seager Berry, from the Building Act department of the London County Council, represented the respondent. Mr. Gibson said the district surveyor, by the notice he had served, had attempted to bring the teachers' offices and interviewing rooms within the operation of section 78 of the London Building Act—in other words, had attempted to classify them as habitable apartments subject to the statutory requirement that they should be of a minimum height of 8ft. 6in. The rooms in question, which were built on the half-floors of every school, were assigned to the use of teachers partly as an office, partly as a retiring and cloak room, and partly as an interviewing room. It was true that a small kitchener was erected in each, but even that could not be contended to bring them within the definition of an inhabited room. Mr. T. J. Bailey, architect to the School Board, stated that these teachers' rooms were placed in all the schools built by the Board, and varied from 7ft. to 8ft. in height. That in the projected school at Leo-street would be 7ft. 6in. The only furni-

ture provided were a chair, a table, a lavatory basin, and sets of hat-pegs. All these rooms were planned to meet the approval of the Education Department, which, by their inspectors, exercised strict supervision over the use to which they were put. Mr. Ellis Marsland, the respondent, stated that it was within his knowledge that the teachers' rooms were also used for managers' committee meetings. This was corroborated by Mr. W. C. Williams, chairman of the Westmoreland-road (Walworth) group of schools, who added that it was a matter of general complaint among the teachers that their rooms were very "stuffy" in the winter and uncomfortably hot in the summer. The chairman (Mr. Arthur Cates) said that, taking into consideration the way in which the rooms were used, the tribunal had decided to allow the appeal; but he must point out that the rooms must be used strictly for the purpose for which the Education Department allowed them to be appropriated.

**HOUSING OF THE WORKING CLASSES.**—**MANNING v. SIMPSON.**—An important decision has been given by his Honour Judge French, Q.C., at Bow County Court, in this case. Under the Housing of the Working Classes Act, 1890, there is in the letting of a house or part of a house for habitation by persons of the working classes an implied condition that the house is reasonably fit for human habitation, and the meaning of habitation "by persons of the working classes" is habitation of a house or part of a "house at a rent not exceeding the sum named as the limit of composition of rates by section 3 of the Poor Rate Assessment and Collection Act, 1869." The limit of composition for rates under that Act is a rateable value not exceeding £20 in the Metropolis (other rates for Birmingham, Manchester, and Liverpool), and £8 if situate elsewhere. The plaintiff sued for damages for breach of the condition of a tenancy of a house situate at Forest-gate, in the borough of West Ham, the rateable value of which was more than £8, and less than £20. Mr. Newson, for the defendant, objected that West Ham was not in the Metropolis within the meaning of the Act of 1869, because, by section 20 of that Act, the word "Metropolis" included only the Metropolis as defined by the Metropolis Management Act, 1855, which defined the word so as to include only certain parishes and places mentioned in the schedule of that Act, and the borough of West Ham was not among them. Mr. Minton-Sentouse, for the plaintiff, agreed with that statement of the law so far as it went. The borough of West Ham, however, had obtained a private Act of Parliament, by which section 3 of the Act of 1869 is "in force within the parish of West Ham, as if such parish were situated in the Metropolis." So that a house in West Ham was "situate in the Metropolis"; and if the rateable value was under £20, it would be a house within the meaning of the Housing of the Working Classes Act, 1890. His Honour said that it was clear that West Ham was "in the Metropolis" within the meaning of the Act of 1869. The point was of great importance to a large number of poor people in the neighbourhood of the Metropolis, and it would be of service to them to know that they were entitled to the benefits conferred by the Housing of the Working Classes Act, 1890.

The Perpendicular oak tracery and carvings in St. Mary's Church, Hurley, have just been restored by Mr. Sergeant, builder, Hænrenham Hill, near Henley-on-Thames.

The joint hospital committee for the Auckland, Shildon, and Willington District have approved the plans of the infectious diseases hospitals they propose erecting. The plans have been prepared by Mr. Wm. Perkins, M.S.A., architect, Bishop Auckland.

The Admiralty have accepted the tender of Messrs. Woodman, Hill, and Co., of Gosport, for the construction of the breakwater for the protection of the harbour. Messrs. Woodman and Co. built the dolphins, which have recently been completed in the line of the breakwater at a cost of £40,000. The breakwater is expected to cost nearly three-quarters of a million, and to take three years in construction. The quantity of stone required, which is to be obtained from the local quarries, is put at ten million tons.

Some time ago an Act was obtained empowering the harbour commissioners of Hastings to construct a harbour, and raise £200,000 for the purpose. The area of the harbour was to be 27 acres, with a depth at low water spring tides of 12ft. and 25ft. at high water. A contract was obtained in 1896 for the construction of the pier for £120,000. Only £118,000 of the capital could be obtained, but the work proceeded. The western pier has been carried out 1,550ft., leaving 350ft. yet to finish, and also the eastern pier and other works. Further money is required to carry on the works, and, unless this can be obtained the harbour cannot be finished, as the Hastings Corporation have declined to help the promoters.

## Our Office Table.

THE Dean and Chapter of Westminster have done wisely in appointing Mr. J. T. Micklethwaite to the position of architect to the Abbey buildings at Westminster. His sometime partner, Mr. Somers Clarke, occupies the same position in respect to St. Paul's Cathedral, and it would have been difficult to have made a better choice in either instance. Both gentlemen are well qualified for their official positions, and, so far as the Abbey buildings are concerned, no one is better acquainted with their history or archaeology than Mr. Micklethwaite. Under Sir Gilbert Scott he had special facilities for acquiring a knowledge of the great Church of St. Peter and its precincts. This knowledge he has developed, and although we are well aware that Mr. Micklethwaite takes a somewhat different view of restoration to that held by his predecessor in the office of architect to the Dean and Chapter of Westminster, we have little doubt but that he will continue to preserve the fabric and renovate its faulty or constructionally weak parts with an equally conservative care as that exercised by Mr. Pearson. To be in office, moreover, entails the advantage of being criticised, and the new surveyor to the Abbey is little likely to escape in this respect any more than his predecessors, even although he does belong to the Society for the Preservation of Ancient Buildings.

In the current issue of the *A.A. Notes*, Mr. H. Seton Morris gives the following copy of a circular which has been sent to the benefited clergy in the diocese of—: "Revd. Sir,—Having been appointed Surveyor of Ecclesiastical Dilapidations for the Diocese of—, I have, as you will see from the above, opened offices on the first floor of—, where I purpose to carry on my practice in conjunction with my present offices at—; and trust that by careful attention, and doing my best to study the wishes of each of my several clients, I may continue to receive the honor of their confidence for future work, and their interest amongst their friends. Allow me to point out that in addition to the work of preparing plans and specifications, and superintending the execution of buildings, I take up the particular points of Arbitrations, Dilapidations, &c., of which I have made a special study. Trusting to be favoured with your further esteemed commands, I am, your obedient servant, —, F.R.I.B.A., Diocesan Surveyor."

In the Chancery Division of the High Court of Justice, an application was recently made that the apprenticeship deed of a ward of Court should be settled by the Plumbers' Company, and a form drawn up by the company has been approved by the judge, Mr. Justice Romer. In addition to the usual provisions based on the indenture for apprentices in the City of London, approved by resolution of the Court of Common Council, April, 1889, special covenants were inserted "binding the apprentice to diligently attend evening classes of technical instruction as directed by the master under penalty of a reduction in wages, and binding the master to provide for attendance of the apprentice at the courses of instruction and the examination in knowledge of sanitary plumbing and workmanship prescribed by the Plumbers' Company or any statutory body empowered to keep a register of qualified plumbers." These covenants were introduced with the object of encouraging and promoting the apprentice's efficiency, and are novel in the practice of the City of London and the Court of Chancery.

The endowment fund of the Home Arts and Industries Association, founded by Mr. G. F. Watts, R.A., Earl Browlow, Mr. J. Passmore Edwards, Lord Burton, and others, with the co-operation of some of the City Companies, is progressing, and now amounts to £2,595 7s., and the interest gained from this sum facilitates the work of the association. The report of the society for 1897 has just been issued, showing a gratifying progress during the past twelve months, no less than thirty new classes having become affiliated since the beginning of the year. An endeavour is wisely being made, in association with the technical instruction committees of local county councils throughout the country, to develop the class-teaching carried on by the Home Arts and Industries Association. A larger number of designs, principally of wood, metal, and leather work, have been added to the collection of the association, including a graduated series of four-

teen exercises designed by Mr. J. Phillips, of Altrincham, and some more advanced studies by Mr. Arthur Simpson, of Kendal. Mr. J. Williams, formerly of the Guild and School of Handicraft, has contributed some designs for metal repoussé work. The annual exhibition of class work is to be held at the Albert Hall from May 19 to 23 next. The various agencies for furthering the advantage or amusement of young people in many villages are found to compete with the work of this association, and the falling off of attendances is attributed in some cases to the rival attractions of the life and drum band, the Band of Hope, and other social meetings. Has not this sort of thing also been the experience at the Architectural Association, too, where the Lyric Club has so many ardent votaries? With the Home Arts and Industries local classes the difficulty referred to is a very real one, as the co-operation and grants from county councils can only be secured when an average attendance is maintained. This is a very proper rule, provided the average is proportionately adjusted to the size of the village or district.

MR. ALFRED MALCOLM, of Clayton, read a paper on practical and theoretical lead-burning to the members of the Manchester branch of the National Registration of Plumbers at the Technical Plumbing School in that city on Friday last. Mr. Malcolm said lead-burning is more essentially a plumber's work than what is more often tacked on to his business—namely, painting, glazing, and paperhanging. He showed a piece of lead pipe unearthed at Pompeii. It is formed out of cast sheet-lead and burnt along the edges, and he doubted whether solder would have stood the test of 2,000 years so well. The men who made such pipes were plumbers, more so than those who to-day buy all their pipes and everything else ready-made, thus reducing the so-called plumber to some extent to the level of a mere fitter. Specimens of burnt joints obtained in the vicinity of Manchester were shown to illustrate the methods in times gone by. The modern method, although now nearly sixty years old, is the use of a flame to melt the edges of the lead instead of pouring on the molten metal. Mr. Malcolm described the mode of work and practically illustrated the best process. He said the burning was the nearest approach to solid drawn work, and joints could be made that would resist more pressure than the pipes upon which they were made.

MR. ALFRED M. FOWLER, M.Inst.C.E., of Manchester and Westminster, formerly borough engineer of Leeds, Sheffield, and Newcastle-on-Tyne, has been interviewed by the representative of a Manchester journal with reference to the relative merits of wood and granite paving. Mr. T. de Courcy Meade, the city surveyor of Manchester, having reported that whilst wood was noiseless, granite was impervious, comparatively inexpensive, and exceedingly durable. Mr. Fowler, on the other hand, states that the advantages of wood or asphalt are more than compensated for any extra cost over granite. The wear and tear of horseflesh and of wheels should be taken into consideration; and whereas granite is dangerous to horses in all states of the weather, wood and asphalt are only so at certain times. When tramways are laid in wood-paved roads, the blocks should be, he holds, laid perfectly level with the rail, and not projecting above it. Karri and Jarrah are the best woods, he thinks, for paving; but upon sanitary grounds asphalt is, he says, *par excellence* the best material.

To encourage their apprentices to become efficient in the arts of designing and writing on wood or glass the Yorkshire Master Painters' Association offer prizes for competition each year. The classes are divided into two standards, the first being for apprentices over eighteen and under twenty-one years of age, and the second for apprentices under eighteen, but in three classes apprentices of any age are entitled to compete. The tenth annual exhibition of works sent in for competition was opened on Friday in one of the stock-rooms of the Golden Lion Hotel, Leeds. The judges were Mr. Joseph Walker, Headingley, Leeds; Mr. F. J. Pickersgill, Woodhouse-lane, Leeds; and Mr. R. Wheatley, Pontefract. They were of opinion that the specimens shown are superior to those exhibited last year, the improvement being especially noticeable in the writing, the samples of pollard oak, and the marbles. The decorated panels and the lead-pencil designs are also very good.

The *American Shipbuilder* devotes an article to the subject of "Ventilation of Ships," which

has not, till recently, had anything like the attention which it deserves. Ventilation of houses on land, though certainly important, cannot, by the nature of things, be so utterly dependent on art as is that of ships. The result has been that the atmosphere of sea-going vessels, in anything approaching bad weather, has become proverbially offensive. The bell-mouthed ventilators are, at best, only a fair-weather contrivance; they admit water quite as readily as air, and therefore, in bad weather, when they are most needed, they fail utterly. Robert Boyle's system of ventilation, however (says our contemporary), remedies all this. There is no necessity to force down the air, because it provides, as any rational system must provide, up-cast shafts for the removal of foul air, as well as down-cast shafts for the introduction of fresh air. There being now no forcing to make room for fresh air, larger quantities will naturally go in. The great cowls which retarded the ship's way are dispensed with, and, most important of all, the intakes and outtakes, though freely open to air, are impervious to water. Thus, even in the roughest weather the ventilators remain open and at work. The ingenuity of the arrangement is very great, and there is no doubt that Mr. Boyle has solved the problem of making a foul-weather ventilator. The speciality is not, moreover, one which appeals merely to the owner of gilt-edged ships; the humblest carrier of coal will find its value. For cattle-steamers and for such perishable cargoes as fruit it is very necessary, and many times the cost of an installation may be lost on a single voyage in bad weather by adhering to the other haphazard system.

#### MEETINGS FOR THE ENSUING WEEK.

MONDAY.—Royal Institute of British Architects. Business Meeting. 8 p.m.

Society of Engineers. "Reservoir Embankments," by William Fox, Royal United Service Institution, Whitehall. 7.30 p.m.

Carpenters' Hall Lectures. "Wood-Carving: its Design and Practice," by Lewis Foreman Day. 8 p.m.

Surveyors' Institution. "Land Surveying and Valuation in Northern India," by W. Irvine. 8 p.m.

Society of Arts. "The Principles of Design in Form," Cantor Lecture No. 4, by Hugh Stannus. 8 p.m.

The Liverpool Architectural Society. "Siena and Baldassarre Peruzzi," by F. W. Bedford.

TUESDAY.—Society of Arts. "The Making of a Stained Glass Window," by Lewis Foreman Day. 8 p.m.

Institution of Civil Engineers. Discussion on "Alternating Current Motors" and "The Dublin Electric Tramway." 8 p.m.

WEDNESDAY.—Architects' Benevolent Society. Annual Meeting at 9, Conduit-street, W. 5 p.m.

Society of Arts. "Linde's Method of Producing Extreme Cold and Liquefying Air," by Professor J. A. Ewing, F.R.S. 8 p.m.

St. Paul's Ecclesiastical Society. "The Coronation Services of the English and French Kings," by the Rev. E. S. Dewick, F.S.A. 7.30 p.m.

THURSDAY.—Society of Arts. "India and Sir Henry Maine," by Charles Lewis Tupper, C.S.I. 4.30 p.m.

FRIDAY.—Architectural Association. "Scottish Ecclesiastical Architecture in the 14th and 15th Centuries," by Hippolyte J. Blanc, A.R.S.A., of Edinburgh. 7.30 p.m.

Birmingham Architectural Association. "The B.A.A. Excursion to Tewkesbury," by John Ward.

SATURDAY.—Edinburgh Architectural Association. Visit to Leith Academy.

Architectural Association. Visit to Public Baths at junction of New Cross-road and Lewisham High-road. 3 p.m.

#### THE ARCHITECTURAL ASSOCIATION.

MARCH 11th, ORDINARY MEETING, 9, Conduit-street, W., at 7.30 p.m. MR. HIPPOLYTE J. BLANC, A.R.S.A., on "SCOTTISH ECCLESIASTICAL ARCHITECTURE of the 14th and 15th CENTURIES" (Lecture Notes).

MARCH 12th, SPRING VISIT to the new Public Baths, New Cross-road, 3 p.m. By kind permission of the Architect, Mr. THOS. DINWIDDY. Entrances in Laurier-grove. Frequent trams to New Cross by Met., S.E., L.B. and S.C. Railways.

G. B. CARVILL, } Hon. Seca.

The Viceroy of India unveiled on Wednesday a statue of Field Marshal Lord Roberts on the Red-road, Mardar, near Calcutta. It has been executed by Mr. Henry Bates, A.R.A.

The Moored Outfall Works are nearing completion, and will shortly be used in connection with the drainage of the parish of Mangotsfield, near Bristol. Mr. W. L. Le Maitre is the engineer, and the total cost of works will be about £6,000.

## Trade News.

### WAGES MOVEMENTS.

ABERDEEN.—The annual general meeting of the members of the Aberdeen Granite Association was held on Friday evening in the North Silver-street Hall, Bailie Taggart in the chair. An application from the United Operative Granite-Cutters' Union was submitted for an increase of 1d. on the standard rate of wages, making 7½d. instead of 6½d. After discussion it was agreed to offer the men a rise on the standard rate of wages of ½d., making the rate 7d.

BRISTOL.—Various branches of the building trades in Bristol have issued notices asking for an advance of wages and a reduction of hours, to come into operation on the first of July next. During the past week meetings of representatives of the men have been held for the purpose of formulating their proposals, which are about to be considered at a meeting of the Masters' Association.

COVENTRY.—The dispute between the Coventry master builders and the plumbers and painters has been settled. A joint meeting of delegates from masters and men was held last week, at which a compromise was offered by the employers. The masters agreed to concede the men's demands of ½l. per hour increase of wages, provided that they in turn agreed to abide by the old code of working rules, which had been in force for some years, and forego the alterations then demanded. The plumbers' and painters' representatives were unable to give a decisive answer at once; but they have since written agreeing to the masters' terms. The question of the demands which the carpenters made has not yet been settled.

LEICESTER.—The attempt of the employers and operatives in the local building trade to arrive at a friendly agreement with respect to the questions which have been opened has so far failed. The carpenters and joiners applied that their wages should be advanced ½d. per hour, and that their hours of labour should at the same time be reduced by three and a half during eight months of the year, and by one during the remainder. The employers, on the other hand, offered a reduction of two and a half hours during certain months. At the first conference the representatives agreed to a provisional basis of settlement on the concession of the ½d. and the 54 hours week during the eight months. The trade union has since adopted this as a basis of arrangement. It has, however, been rejected by the Master Builders' Association, and no other *modus vivendi* has been arranged. The formal notices of the workmen do not expire until the close of the present month, and there is thus time for conciliatory counsels to prevail.

PLYMOUTH.—The journeyman painters and house decorators of Plymouth having made demands for an increase of wages and shortening of working hours, a conference has taken place between the employers and a deputation from the Amalgamated Society of House Decorators and Painters. The result is that in future the men will be paid 7d. per hour, and work will cease at 12 o'clock on Saturdays and at 5.30 on other days, on and after to-morrow (Saturday).

TUNBRIDGE WELLS.—The house painters of this town have made a compromise in the matter of a demand of an advance of 1d. an hour in wages, from 7d. to 8d., and thus a probable dispute has been averted. Although the Masters' Federation has been practically dissolved, the leading firms severally have offered to the employes an advance of ½d., and at a general meeting of the trade (society and non-society men), convened at the Friendly Societies' Hall on Wednesday week, the proposal was accepted.

A pipe-organ, erected by Messrs. H. S. Vincent and Co., Sunderland, was inaugurated on Sunday in the Buccleuch Street United Presbyterian Church, Dalkeith.

The Rowton Trustees have purchased a freehold site at Hammersmith, on which they propose to build a fourth lodging house for men, similar to those in Vauxhall, King's Cross, and Newington-butts, to contain 600 beds.

The new board schools which have been erected at Carnarvon, on a site adjoining the Pavilion, were opened on Tuesday. The cost of the building is about £6,000. The architect was Mr. Rowland Lloyd-Jones; Mr. Owen Morris being the contractor.

A new Wesleyan chapel, Early Perpendicular in style, and seated for 624 persons, has just been built at Barry, at a cost of £3,400. The walls are of Newbridge stone, with Bath stone dressings, and the roof is in one span, the roof-trusses being carried by pilasters of Bath stone. Mr. Budgeon, of Cardiff, was the architect, and Messrs. Evans Brothers, of the same town, the contractors.

LIST OF COMPETITIONS OPEN.

Peterborough—Additions to the Old Guildhall (limit £2,000, exclusive of fittings and furniture) .....	£25 (and 5 per cent. com.), £15, £10	W. Wellows, Town Clerk, Guildhall, Peterborough .....	Mar. 7
Barking, E.—Bandstand for Recreation Ground (£200 limit) .....		C. J. Dawson, F.R.I.B.A., Surveyor U.D.C., East-street, Barking .....	8
Carlisle—Silver Gilt Casket (to cost £63) .....		A. H. Collingwood, Town Clerk, 15, Fisher-street, Carlisle .....	12
Blangden-on-Tweed—Police-Station (£5,000 limit) .....	Commission or £50, £25	R. Weddell, Town Clerk, Berwick-on-Tweed .....	14
Llangathen—Stone Bridge, Dryslwyn Ford .....	Carmarthen County Council	Thomas Jones, Clerk, County Council Offices, Llandoverly .....	14
Winchester—Public Baths .....	£25, £15	Walter Bailey, Town Clerk, Guildhall, Winchester .....	31
Belper—Sewage Disposal Schemes .....	50 Guineas, 25 Guineas	Joseph Pym, Clerk, Belper .....	May 1
Warrington—Police Station, Court House, &c. .....	£100, £50, £25	J. Lyon Whittle, Clerk, Town Hall, Warrington .....	July 2
Stockholm—City Railway Stations and Junctions .....	£656, £498, £219	Consulate General, 27, Great Winchester-street, E.C. .....	Aug. 31
West Bangour, Linnithgowshire—Lunatic Asylum (limited to Scotch Architects) .....	£250, £200, £150, £100	A. Ferrier, Clerk, Parish Council Chambers, Castle-terr., Edinburgh .....	—
Royal Aquarium—Design for Poster .....	10 Guineas	Edgar S. Shrubsole, Royal Aquarium, London .....	—
Southwold—Pair of Villas, Church Green .....		E. W. Moore, High-street, Southwold .....	—
Linnithgow—County Offices .....	£31 10s., £15 15s.	W. H. Henderson, County Clerk, Linnithgow .....	—

LIST OF TENDERS OPEN.

BUILDINGS.

Hunslet—Alteration of Cottages, Aloe-street and Roland-street .....	Mrs. M. A. Holdsworth .....	John E. Preston, Architect, Chapel-Allerton .....	Mar. 5
Colton—Mission Church .....	J. T. Jackson .....	E. M. Lawson-Smith, Colton Lodge, Tadcaster .....	5
Christchurch—Shed at Workhouse .....	Guardians .....	A. Druitt, Clerk, Christchurch, Hants .....	5
Mullingar—Chronic Block and Farm Offices, Lunatic Asylum .....	School Board .....	H. Williams, Secretary, Board of Control, Custom House, Dublin .....	5
Perth—School Enlargement, South William-street .....	Guardians .....	P. Martin, Clerk, 33, Tay-street, Perth .....	5
Oakenshaw—Additions to Schools .....	J. Andrassy .....	J. W. Broughton, Architect, 19, High-street, Skipton .....	5
Newry—Dispensary Building .....	Midland Railway Company .....	W. R. Bell, Clerk, Workhouse, Newry .....	5
Craik—Police Station .....	Trustees .....	David Henry, Architect, St. Andrews .....	5
Castleford—Dwelling—House and Stables, Back Bridge-street .....	John Fenn .....	Arthur Hartley, Architect, Carlton Chambers, Castleford .....	5
Newcastle-on-Tyne—Cambois Mission Church .....	Whitechapel Union Guardians .....	Hicks and Carlewood, Architects, 42, Grainger-st., Newcastle-on-T. .....	5
Leicester—Offices and Messrooms .....	J. T. Jackson .....	Secretary of the Way and Works Committee, Midland Ry., Derby .....	5
Cullingworth—Joiner's Shop .....	Standish-with-Langtree D.C. .....	Joshua Robertshaw and Son, Architects, 55, Tyrel-street, Bradford .....	5
Caerwrlle—Wesleyan Chapel .....	Guardians .....	John Halliwell, High-street, Caerwrlle .....	5
Darfield—Two Houses, Vicarage-lane .....	Dumbarton County Council .....	Jno. Robinson, Wombwell .....	5
Ardleigh—Six Cottages and a Shop .....	William Lawrence and Co. .....	P. M. Beaumont, Architect, Maldon .....	5
Mile End-road—Dining Hall and Lavatory Blocks at Work-house, South-grove .....	Town Commissioners .....	W. Vallance, Clerk, Union Offices, Vallance-road, E. .....	7
Ikley—Shops and Offices .....	Parks Committee .....	Isitt, Adkin, and Hill, Architects, Prudential Buildings, Bradford .....	7
Standish—Drinking Fountain and Road-Making .....	George Haigh .....	J. H. Richards, Clerk, Standish, Near Wigan .....	7
Goole—Alterations to Workhouse .....	Great Western Railway Co. .....	E. C. B. Tudor, Surveyor, 48, Burlington-crescent, Goole .....	7
Exminster—Extensions to Devon County Asylum .....	Brundrit and Co. .....	E. H. Harbottle, Architect, County Chambers, Exeter .....	7
Dumbarton—Council Chambers .....	Radcliffe Infirmary Committee .....	D. M'Naughtan, I.A., 137, West Regent-street, Glasgow .....	7
Colwick—Cabinet Manufactory .....	Great Western Railway Co. .....	W. B. Starr, Architect, 12, St. Peter's-gate, Nottingham .....	7
Wicklow—Eighteen Artisans' Dwellings .....	Barnes Urban District Council .....	F. W. McPhail, Town Hall, Wicklow .....	7
Halifax—Shelter Pavilion, Akroyd Park .....	Cramlington Co-operative Society .....	Edward S. Esott, C.E., Borough Engineer, Town Hall, Halifax .....	7
Linthwaite—Converting Warehouse into Three Cottages at Bankfield .....	Great Western Railway Co. .....	J. Berry, Architect, 9, Queen-street, Huddersfield .....	8
Notsgrove Station—Cottage .....	Brundrit and Co. .....	G. K. Mills, Secretary, Paddington Station, W. .....	8
Blaydon-on-Tyne—United Methodist Free Church .....	Radcliffe Infirmary Committee .....	T. C. Nicholson & E. Bowman, Architects, 52, Westgate-rd., N.-on-T. .....	8
Penmaenmawr—Thirty-one Cottages .....	Great Western Railway Co. .....	Richard Davies, Architect, Bangor .....	8
Oxford—Additions, Administrative Block .....	Barnes Urban District Council .....	W. H. Castle, Surveyor, Town Hall, Oxford .....	8
Redruth—Roofs to Station Buildings .....	Cramlington Co-operative Society .....	G. K. Mills, Secretary, Paddington Station, W. .....	8
Oxford—Additions, Administrative Block .....	Great Western Railway Co. .....	S. Adams, Clerk, 56, North Bondgate, Bishop Auckland .....	8
Avonmouth—Two Crossing Cottages .....	Corporation .....	G. K. Mills, Secretary, Paddington Station, W. .....	8
Mortlake—Convalescent Block, South Worpole Way Hospital .....	Rev. R. Gardiner .....	G. B. Tomes, Surveyor, High-street, Mortlake, S.W. .....	8
Cramlington—Store Premises at Dudley Branch .....	Toxteth Board of Guardians .....	J. G. Clone, Architect, 50, Grainger-street, Newcastle-on-Tyne .....	8
Penshore—New Station .....	Town Council .....	G. K. Mills, Secretary, Paddington Station, W. .....	8
Eccles—Additions and Alterations to Public Baths, Milton-street, Patricroft .....	Right Rev. Monsignor Walker .....	Geo. Wm. Bailey, Town Clerk, Town Hall, Eccles .....	9
Bretherton—Restoration and Reseating of St. John's Church .....	Great Central Railway Co. .....	Austin and Paley, Architects, Lancaster .....	9
Leeds—Alterations to Boyle Hall .....	Town Council .....	Nelson & Savage, Architects, Sun Buildings, 15, Park-row, Leeds .....	9
Liverpool—Alterations, Workhouse Infirmary, Smithdown-road .....	Right Rev. Monsignor Walker .....	J. Moulding, Clerk, 15, High Park-street, Liverpool .....	9
Scarborough—House, North Foreshore-road .....	Very Rev. P. Pentony .....	H. W. Smith, Borough Surveyor, Scarborough .....	9
Kincaasslagh—New Ceiling to Church .....	Corporation .....	Edward J. Toye, Architect, Strand, Derry .....	10
Middlezeoy—Wesleyan Church .....	J. F. Donald .....	Bowring and Hawkins, Surveyors, 11, High-street, Glastonbury .....	10
Sheffield—Panels, Offices, and Subway .....	Mawgan-in-Meneage School Board .....	Oliver S. Holt, Secretary, London-road Station, Manchester .....	10
Croydon—Greenhouse at Cemetery, Mitcham-road .....	Bentley's Yorkshire Breweries .....	E. Mawdesley, Town Clerk, Town Hall, Croydon .....	10
Grimsbay—School Chapel, Heneage-street .....	West Ham Town Council .....	Geo. H. Eyes, 154, Freeman-street, Grimsby .....	10
Trelewis—Hotel .....	School Board .....	T. Roderick, Architect, Clifton-street, Abereare .....	10
Burton Port—Church .....	Corporation .....	Edward J. Toye, Architect, Strand, Derry .....	10
Bridlington—Baptist Sunday School .....	J. F. Donald .....	T. Grimshaw, St. John-street, Bridlington .....	10
Stabannon Church—Tower and Spire .....	Mawgan-in-Meneage School Board .....	W. H. Byrne, Architect, 20, Suffolk-street, Dublin .....	10
Elmswell—Wesleyan Chapel .....	Bentley's Yorkshire Breweries .....	Eade and Johns, Architects, Cornhill Chambers, Ipswich .....	11
Harrogate—Villa, Leeds-road .....	West Ham Town Council .....	Charles E. Marsden, Architect, 3, John-street, Bradford .....	11
Norwich—Erection and Maintenance of Technical Institute (for Six Months) .....	School Board .....	Geo. B. Kennett, Town Clerk, Guildhall, Norwich .....	12
Hipperholme—Detached Residence .....	Corporation .....	R. Berry, Architect, Arcade Chambers, Commercial-street, Halifax .....	12
Seaton—Two Villas .....	J. F. Donald .....	J. Donald, Architect, John-street, Warrington .....	12
Halifax—Villa, Skircoat Green-road .....	Mawgan-in-Meneage School Board .....	Geo. Buckley and Son, Architects, Tower Chambers, Halifax .....	12
Mawgan—Additions and Alterations to Garras Board School .....	Bentley's Yorkshire Breweries .....	J. W. G. Bartlett, Boscawen, Cury .....	12
Cloughjordan—Schoolroom and Vestry, Methodist Church .....	West Ham Town Council .....	Rev. John G. Whittaker, The Manse, Cloughjordan .....	12
Baldon Green—Hotel .....	School Board .....	B. Wood Higgins, Architect and Surveyor, Outton, Leeds .....	12
Chadwell Heath—Superstructure of Lunatic Asylum (800 patients) .....	Corporation .....	Fred. E. Hilleary, Town Clerk, Town Hall, West Ham, E. .....	14
Walsall—Whitehall Schools (765 places) .....	J. F. Donald .....	A. Jeffries, Clerk, Bradford-street, Walsall .....	14
Deal—Ladies' Cloakroom, South Parade .....	Mawgan-in-Meneage School Board .....	Thos. C. Golder, Borough Surveyor, 23, Queen-street, Deal .....	14
Dartford—Additional Buildings, West Hill .....	Bentley's Yorkshire Breweries .....	J. C. Hayward, Clerk, Sessions House, Dartford .....	14
Salford—School, Dansky-road .....	West Ham Town Council .....	D. Duthie, Clerk, Chapel-street, Salford .....	14
Ipswich—Enlargement of Boys' Department, Wherstead-road School .....	School Board .....	J. Hepburn Hume, Clerk, Tower House, Tower-street, Ipswich .....	15
Battersea—Superstructure of Fire-Brigade Station in Bridge-rd. .....	Corporation .....	C. J. Stewart, Clerk, Spring-gardens, S.W. .....	15
Edmonton, N.—Board-room and Offices, Union-road .....	Guardians of Edmonton Union .....	Francis Shelton, Clerk, Lower Tottenham .....	15
Hirst—Branch Store and Manager's House .....	Ashington Equitable Store .....	J. English, Secretary, Ashington .....	15
Liverpool—Warehouse at North Docks Goods Yard .....	Lancashire and Yorkshire Ry. Co. .....	C. W. Bayley, Secretary, Hunt's Bank, Manchester .....	15
London, W.—Two New Ward Blocks, &c., at Workhouse, Northumberland-street .....	St. Marylebone Guardians .....	Hy. T. Dudman, Clerk, Guardian's Offices, Northumberland-st., W. .....	15
Erdington, near Birmingham—Cottage Homes .....	Aston Union Guardians .....	John North, Clerk, Union Offices, Vauxhall-road, Birmingham .....	15
Lewisham—Fire-Engine Station, High-street .....	London County Council .....	C. J. Stewart, Clerk, Spring-gardens, S.W. .....	15
Brentwood—Technical Workshops at Hackney Union Schools .....	Hackney Union Guardians .....	Frank R. Coles, Clerk's Offices, Hackney Union, Homerton, N.E. .....	16
Harrow—Disinfecting Buildings, &c. .....	Urban District Council .....	T. Charles, Surveyor, Harrow .....	16
Regent's Park, N.W.—Brick Chimney Shaft (about 240ft. high) at Electricity Works .....	St. Pancras Vestry .....	C. H. F. Barrett, Clerk, Vestry Hall, Pancras-road, London, N.W. .....	17
North Weald, Essex—New Schools .....	Mild End Old Town Guardians .....	Wm. Thacker, Clerk, Guardians' Offices, Bancroft-road, London, E. .....	17
King's Norton—Police Station Buildings, Stirchley-street .....	Worcestershire County Council .....	Henry Rowe, County Surveyor, Worcester .....	18
Sowerby Bridge—Three Shops, Sharp-street .....	Blair Smith .....	Horstall and Son, Architects, Low-street, Halifax .....	19
Accrington—Wesleyan Day and Sunday School, Spring Hill .....	Ecclesial Bierlow Union Guardians .....	Henry Ross, Architect, Cannon-street, Accrington .....	19
Londonderry—House .....	Guardians .....	W. E. Pinkerton, M.R.I.A.I., Architect, 8, Diamond, Londonderry .....	21
Sheffield—Male Infirmary Ward at Workhouse .....	Rev. B. Mulholland, P.P., Coleraine .....	Thomas W. Smith, Clerk, Union Offices, The Edge, Sheffield .....	21
Brighton—Infirmary Buildings for Children .....	Windsor Union Guardians .....	B. Burfield, Clerk, Parochial Offices, Brighton .....	22
Aghadowey—New Church .....	St. Pancras Vestry .....	J. J. O'Shea, Architect, Marsh's-buildings, 121, Donegall-st., Belfast .....	25
Old Windsor—New Infirmary Buildings, &c., at Workhouse .....	Mild End Old Town Guardians .....	Philip Lovegrove, Clerk, 32, Park-street, Windsor .....	April 2
Leeds—Five Houses, Brudenell-road .....	Worcestershire County Council .....	W. Squires, Architect, Royal Exchange Chambers, Leeds .....	—
Keighley—Bonding Warehouse, Cooke-street .....	Blair Smith .....	John Judson and Moore, Architects, York Chambers, Keighley .....	—
Harrogate—Pair of Houses in Park Drive .....	Ecclesial Bierlow Union Guardians .....	J. F. Royce, 9, Station-square, Harrogate .....	—
Winchester—Cottages, Queensland Estate .....	Guardians .....	W. Burrough Hill, Architect, Southampton .....	—
Dalmany—Cottage .....	Rev. B. Mulholland, P.P., Coleraine .....	Colin C. MacGilp, Estate Office, Dalmany .....	—
Wardleworth—Branch Shop .....	Windsor Union Guardians .....	George A. Hammond, Architect, &c., Rochdale and Heywood .....	—

BUILDINGS—continued.

Table listing building projects and architects. Includes entries for Camborne, Bramley, Middlewood, Honor Oak, West Kenton, West Ardsley, Kendal, Leeds, Insh, Low Baildon, Manchester, Llangennech, Herne Bay, Epsom, Exmouth, Hull, Llanelly, Burnley, Exmouth, Otley, North Salford, Baxton, Ruabon, Ashton-under-Lyne, Ramsgate, Whitgift, Selby, Shirebrook, Oswestry, Plymouth, Nottingham, Harrogate, Nottingham, Peterborough, Tottenham, Littleborough, Leeds, Kimberworth, Heywood, Colchester, Carlisle, Basingstoke, Chesterfield, Carlisle, Northwich, Cashel, Warrington, London, West Derby, Coventry, Leeds, Appleton, Buxton, Rainham, Church Aston, Lochmaddy, Market Rasen, Harwich, Dorstone, Lincoln, Glasgow, Pembroke Dock, Bewcastle, Morpeth, Lowestoft, Prestwich, Egremont, Sophia, Blackpool, Swinton, Southampton, Buncrana, Madras, Bradford, Bramshall, Darlington, Alton, Weymouth, Bacup, Hastings, Shrewsbury, Hackney Wick, Gretna Green, Carrick-on-Suir, Ashby-de-la-Zouch, Birkenhead, Durham, Prescott, Grimsby, Sedgley, Darwin, Bermondsey, Manchester, Shooter's Hill, Buxton, Birmingham, Stafford.

ENGINEERING.

Table listing engineering projects and officials. Includes entries for Weaver Navigation Trustees, Town Commissioners, Paving Committee, Bengal and North-Western Ry. Co., Board of Guardians, Electric Lighting Committee, Town Council, Town Council, Northallerton Rural District Council, Urban District Council, Waterworks Co., Newport (Salop) R.D.C., Inverness County Council, Tendring Hundred Waterworks Co., County Council, Highways Committee, Glasgow and South-Western Ry. Co., Town Council, Longtown Rural District Council, Committee of Visitors, Town Council, Prestwich Union Guardians, Wallasey Urban District Council, Corporation, Urban District Council, Corporation, Board of Works, Dublin, Uttoxeter Rural District Council, Alton Gas Company.

FENCING AND WALLS.

Table listing fencing and walling projects. Includes entries for Weymouth, Bacup, Hastings, Shrewsbury, Hackney Wick, Gretna Green, Carrick-on-Suir, Ashby-de-la-Zouch, Birkenhead, Durham, Prescott, Grimsby.

FURNITURE AND FITTINGS.

Table listing furniture and fittings projects. Includes entries for Ashby-de-la-Zouch, Birkenhead, Durham, Prescott, Grimsby.

PAINTING.

Table listing painting projects. Includes entries for Sedgley, Darwin, Bermondsey, Manchester, Shooter's Hill, Buxton, Birmingham, Stafford.



PAINTING—continued.

Kennington Park—Painting Works	London County Council	C. J. Stewart, Clerk, Spring-gardens, S.W.	Mar. 21
Roatal Woods—Painting Works	London County Council	C. J. Stewart, Clerk, Spring-gardens, S.W.	" 21
Ashton-under-Lyne—Painting, Papering, and Decorating 14 Houses		S. Wilkinson, 65, Whiteacre-road, Ashton	—

PLUMBING AND GLAZING.

Eidinchip—Plumbing, &c.	A. H. Ballingall, W.S., Perth	Mar. 12
-------------------------	-------------------------------	---------

ROADS AND STREETS.

Gillingham—Construction and Kerbing of Upper Milton and Chaucer Roads, and Kerbing in Rock-avenue	W. J. McLellan	G. E. Bond, Architect, Rochester	Mar. 5
Barnsley—Street Works in Agnes-road West and Spring-street, and Sewers in Blenheim-road and St. George's-road	Town Council	J. Henry Taylor, Borough Surveyor, St. Mary's-place, Barnsley	" 9
Blyth—Making-up Streets	Cowpen Urban District Council	Robert Grieves, Surveyor, Seaforth-street, Waterloo, Blyth	" 10
Gosforth—Asphalting and Kerbing	Urban District Council	Robert Reay, Clerk, Council Chambers, Gosforth	" 12
Hexham—Street Improvements	Hexham Urban District Council	Wm. Pruddah, Clerk, Hexham	" 12
Wimbledon—Making-up Olive-grove, Fairlawn-road, and Somerset-road	Urban District Council	The Surveyor's Office, The Broadway, Wimbledon	" 14
Godalming—Making-up Holloway Vale-road	Town Council	Samuel Welman, Church-street, Godalming	" 14
Biggleswade—Remaking Footways	Urban District Council	T. J. Hooper, Clerk, Biggleswade	" 15
Croydon—Making-Up Leonard-road, Mitcham, and Park Gate-road, Wallington	Rural District Council	James Wilson, Clerk, Town Hall, Fell-road, Croydon	" 16
Aston Manor—Paving, Kerbing, and Sewering Priory-road	Urban District Council	H. Richardson, Surveyor, Council House, Aston Manor	" 24
Nuneaton—New Street (700 yards)	Far Croft Estate Office	S. P. Stewart, Estate Office, Arbury, Nuneaton	—
Handsworth—New Roads (over two miles)	Church Stretton Land Co.	William Roberts, Land Agent, 37, Waterloo-street, Birmingham	—
Church Stretton—Construction of Roads		S. Houtt Horton, Architect, Effingham House, Arundel-street, W.C.	—

SANITARY.

Upton—Relaying Sewers, &c.	Wirral Rural District Council	J. E. S. Ollive, Clerk, 54, Hamilton-street, Birkenhead	Mar. 7
Llanely—Sewerage Works, Forge and Pembrey-road District	Urban District Council	Henry W. Spowart, Clerk, Town Hall, Llanely	" 7
Heswall-cum-Oldfield—Sewers	Wirral Rural District Council	J. E. S. Ollive, Clerk, 54, Hamilton-street, Birkenhead	" 7
Tonypreail—Sewers, &c.	Llantrisant & Llantwit Fardre R.D.C	Gomer S. Morgan, Surveyor, Pontycun	" 9
Chase Town—Sewerage Works, &c.	Lichfield Rural District Council	John Derry, Clerk, Lichfield	" 12
Broadstairs—Sewerage Works	Urban District Council	Lionel A. Skinner, Clerk, Council Offices, Broadstairs	" 14
Hastings—Surface-Water Drain in Bohemia-road	Corporation	Philip H. Palmer, M.I.C.E., Borough Engineer, Town Hall, Hastings	" 14
Tipperary—Sanitary Works at Workhouse	Guardians of Tipperary Union	E. A. Hackett, M.I.C.E., County Surveyor, Clonmel	" 14
Bebington—Sewer in Stanton-road	Lower Bebbington U.D.C.	Joseph Young, Surveyor, 13, New Chester-road, New Ferry	" 15
Tirelmont—Sewerage Works (estimated cost, £24,000)	Rural District Council	Secretariat Communal, Tirelmont, Belgium	" 15
Rotherham—Laying Pipe Sewers and Outfall Works	Rural District Council	Bernard Godfrey, A.M.I.C.E., 29b, High-street, Rotherham	" 17
Hendon, N.W.—Sewers, &c.	Rural District Council	F. G. Seabrook, Clerk, Union Offices, Edgware	" 17
Burnley—Sewers, &c.	Rural District Council	J. S. Horn, Clerk, 18, Nicholas-street, Burnley	" 18
Walsall—Relaying Drains at Sewage Farm, Besoot	Rural District Council	R. H. Middleton, Borough Surveyor, Bridge-street	" 21
Pokesdown—C.I. Sea Outfall (500 yards, 2in.) & Outfall Sewers	Urban District Council	W. E. Burt, Council Offices, Pokesdown	" 21
Wakefield—Sewers and Surface-water Drains	Corporation	R. Porter, City Engineer, Town Hall, Wakefield	" 21

STEEL AND IRON.

Brighton—Cast-Iron Pipes for Waterworks	Corporation	F. J. Tillstone, Town Clerk, Brighton	Mar. 8
Hull—Cast-Iron Holding-Down Plates (20,000)	Corporation	A. E. White, City Engineer, Hull	" 8
Hereford—Steel and Iron for Bridge over Wye, Castle Green	Victoria Bridge Committee	J. Parker, C.E., Mansion House, Hereford	" 10
Carlisle—Cast-Iron Pipes (630 lineal yards, 3in.)	Corporation	Henry C. Marks, A.M.I.C.E., City Surveyor, 36, Fisher-st., Carlisle	—

STORES.

Brandon—Road Materials (One Year)	Brandon and Byshtotles U.D.C.	John George Wilson, Clerk, North Bailey, Durham	Mar. 5
Barnes—Road Materials (12 Months)	Urban District Council	G. Bruce Tomes, Surveyor, Council Offices, High-st., Mortlake, S.W.	" 7
Southwark—Lime and Cement, Oils and Colours, Timber, Flagging and Granite Kerbing, &c.	St. George-the-Martyr Vestry	J. A. Johnson, Vestry Clerk, Vestry Hall, Borough-road, S.E.	" 7
Bath—Work and Materials (One Year)	Urban Sanitary Authority	Chas. R. Fortune, City Surveyor, Guildhall, Bath	" 8
Bridgwater—Rough Stone (400 tons)	Corporation	W. T. Baker, Town Clerk, Bridgwater	" 8
Bath—Sewer Pipes, &c. (One or Three Years)	Sanitary Committee	Chas. R. Fortune, City Surveyor, Guildhall, Bath	" 8
Belper—Road Materials	Rural District Council	Robt. C. Cordon, Surveyor, Hazelwood, Derby	" 9
Swindon—Road Stone, &c., Timber, Pipes and Bricks, Cement and Lime (One Year)	Swindon New Town U.D.C.	Henry J. Kinneir, Clerk, Public Offices, Swindon	" 12
Billesdon—Granite and Granite Chippings (One Year)	Rural District Council	W. E. Richardson, Clerk, 18, New-street, Leicester	" 12
Rotherhithe, S.E.—Broken Guernsey Granite, Pitching Setts, Ballast and Sand, Lime, Cement, Drain Pipes, &c. (One Year)	Vestry	James J. Stokes, Clerk, Town Hall, Lower-road, Rotherhithe	" 14
St. Thomas (near Exeter)—Road Materials (One Year)	Rural District Council	Arthur E. Ward, 9, Bedford-circus, Exeter	" 14
Manchester—Bricks, Colours (dry and ground), Gas and Water Fittings, Lime, Cement, Earthenware Drains, &c. (One Year)	Great Central Railway Co.	Oliver S. Holt, Secretary, London-road Station, Manchester	" 15
Coventry—Road Materials (during Year)	General Works Committee	J. E. Swindlehurst, City Engineer, St. Mary's Hall, Coventry	" 17
Chailey—Flints (3,425 yards) for Highways	Rural District Council	J. Miles, Clerk, 173, High-street, Lewes	" 19
Downham Market—Broken Granite (200 tons), Slag (200 tons), and Broken Gravel (2,000 yards)	Rural District Council	T. L. Reed, Clerk, Downham Market	" 24
Sleaford—Broken Granite (800 or 1,000 tons)	Urban District Council	Edmund Clements, Clerk, Council Offices, Sleaford	" 26
Swansea—Gravel and Sand (1,500 tons), Unbroken Limestone (1,000 tons), Broken Limestone (1,500 tons), and Broken Syenite (6,000 tons), for Road Metal	Swansea Town Council	Borough Surveyor, 13, Somerset-place, Swansea	—

LATEST PRICES.

IRON, &c.

	Per ton.	Per ton.
Rolled-Iron Joists, Belgian	£6 0 0	£6 10 0
Rolled-Steel Joists, English	6 10 0	7 10 0
Wrought-Iron Grid Plates	5 15 0	6 10 0
Bar Iron, good Staffs	7 0 0	8 0 0
Do., Lowmoor, Flat, Round, or Square	17 0 0	17 0 0
Do., Welsh	5 15 0	5 17 6
Boiler Plates, Iron—		
South Staffs	7 17 6	8 5 0
Best Suedahill	10 0 0	10 10 0
Angles 10s., Tees 20s. per ton extra.		
Builders' Hoop Iron, for bonding, &c., £8 15s. 0d. per ton.		
Builders' Hoop Iron, galvanised, £15 10s. 0d. per ton.		
Galvanised Corrugated Sheet Iron—		
No. 18 to 20.	No. 22 to 24.	
6ft. to 8ft. long, inclusive gauge	Per ton.	Per ton.
Best ditto	£10 15 0	£11 0 0
	11 5 0	11 10 0
Cast-Iron Columns	£6 0 0	£8 10 0
Cast-Iron Stanchions	6 0 0	8 10 0
Cast-Iron Sash Weights	—	4 2 6
Cast-Iron Socket Pipes—		
3in. diameter	5 10 0	5 15 0
4in. to 6in.	5 5 0	5 10 0
7in. to 24in. (all sizes)	4 15 0	5 0 0
[Coated with composition, 2s. 6d. per ton extra; turned and bored joints, 5s. per ton extra.]		
Pig Iron—	Per ton.	
Cold Blast, Lilleshall	106s.	to 110s.
Hot Blast, ditto	57s. 6d.	to 62s. 6d.
Wrought-Iron Tubes—Discount off Standard Lists f.o.b.		
Gas-Tubes	75p.c. Fittings	77p.c.
Water-Tubes	70	" 72
Steam-Tubes	62	" 65
Galvanised Gas-Tubes	60	" 62
Galvanised Water-Tubes	56	" 57
Galvanised Steam-Tubes	46	" 47

	10cwt. casks.	5cwt. casks.
Sheet Zinc, for roofing and work-	Per ton.	Per ton.
ing up	£22 10 0	to £23 10 0
Sheet Lead, 3lb. per sq. ft. super.	14 5 0	" 15 5 0
Pig Lead, in 1cwt. pigs	13 10 0	" 14 10 0
Lead Shot, in 25lb. bags	17 10 0	" 18 10 0
Copper Sheets, sheathing and rods	58 10 0	" 59 10 0
Copper, British Cake and Ingot	51 15 0	" 52 15 0
Tin, Straits	65 10 0	" 66 10 0
Do., English Ingots	68 0 0	" 69 0 0
Spelter, Silesian	17 7 6	" 18 7 6
Cut Clasp Nails, 3in. to 6in.	£8 15 0	" £9 15 0
Cut Floor Brads	8 10 0	" 9 10 0
Wire Nails (Points de Paris)—		
0 to 7	8	9
8/6	9/0	9/6
10/3	11/0	12/0
13/0	14/5	15/0
14/9	16/9	
	per cwt.	B.W.G.

TIMBER.

Teak, Burmah	per load	£13 0 0	to	£15 10 0
" Bangkok	"	10 0 0	"	15 0 0
Quebec pine, pitch	"	2 2 6	"	4 2 6
" yellow	"	3 15 0	"	5 0 0
" Oak	"	2 12 6	"	4 7 6
" Birch	"	3 15 0	"	5 0 0
" Elm	"	3 0 0	"	5 0 0
" Ash	"	2 10 0	"	3 10 0
Dantsic and Memel Oak	"	1 9 0	"	3 9 0
Fir	"	3 5 0	"	5 10 0
Wainscot, Riga p. log	"	4 10 0	"	6 10 0
Lath, Dantsic, p.i.	"	5 0 0	"	6 10 0
St. Petersburg	"	8 5 0	"	8 10 0
Greenheart	"	4 0 0	"	15 0 0
Box	"	0 1 8	"	0 1 10
Sequoia, U.S.A.	per cube foot			
Mahogany, Cuba, per super foot				
lin. thick		0 0 5	"	0 0 6
" Honduras	"	0 0 4	"	0 0 5
" Mexican	"	0 0 4	"	0 0 4
Cedar, Cuba	"	0 0 3	"	0 0 4
" Honduras	"	0 0 3	"	0 0 4
Satinwood	"	0 0 6	"	0 0 7
Walnut, Italian	"	0 0 3	"	0 0 4

Deals, per St. Petersburg Standard, 120—12ft. by 1 1/2in. by 1 1/2in. —

Quebec, Pine, 1st	£19 5 0	to	£25 5 0
" 2nd	13 15 0	"	16 5 0
" 3rd	6 5 0	"	10 15 0
Canada Spruce, 1st	9 5 0	"	11 5 0
" 2nd and 3rd	8 0 0	"	9 0 0
New Brunswick	6 5 0	"	7 5 0
Riga	6 15 0	"	7 15 0
St. Petersburg	8 15 0	"	12 15 0
Swedish	9 0 0	"	15 10 0
Finland	7 10 0	"	8 0 0
White Sea	9 0 0	"	15 10 0
Battens, all sorts	5 0 0	"	18 0 0

Flooring Boards, per square of lin. —

1st prepared	£0 9 0	to	£0 16 6
2nd ditto	0 7 6	"	0 13 0
Other qualities	0 6 0	"	0 7 6

Staves, per standard M.—

Quebec pipe	£35 0 0	to	£42 10 0
U.S. ditto	230 0 0	"	240 0 0
Memel, cr. pipe	230 0 0	"	210 0 0
Memel, black	200 0 0	"	210 0 0

OILS.

Linseed	per ton	£18 0 0	to	£16 16 0
Rapeseed, English pale	"	24 10 0	"	24 15 0
Do., brown	"	22 15 0	"	23 5 0
Cottonseed, refined	"	13 15 0	"	14 5 0
Olive, Spanish	"	33 0 0	"	33 10 0
Seal, pale	"	24 0 0	"	24 10 0
Cocoonut, Cochín	"	28 0 0	"	28 10 0
Do., Ceylon	"	22 0 0	"	22 10 0
Palm, Lagos	"	23 5 0	"	23 10 0
Oleine	"	18 15 0	"	19 15 0
Lubricating U.S.	per gal.	0 6 3	"	0 7 6
Petroleum, refined	"	0 0 4 1/2	"	0 0 4 1/2
Tar, Stockholm	per barrel	1 0 0	"	1 5 0
Do., Archangel	"	0 12 6	"	0 15 0
Turpentine, American	per ton	23 0 0	"	23 10 0

**CHIPS.**

On the motion of Sir W. Walrond in the House of Commons on Wednesday, a select committee was appointed to inquire into and report upon the administration and cost of the museums of the Science and Art Department.

Three stained-glass windows have just been placed in St. Martin's Church, Lowmoor. The subjects represented are "The Holy Family," "Ruth," and "Dorcas." The work is from the studio of Messrs. Abbott and Co., Brock-street, Lancaster.

On Saturday the memorial-stone of the new United Presbyterian church, at present in course of erection on the grounds of Rossbank, West End, Cambuslang, was laid. The buildings consist of a church to accommodate 758, to cost £4,900; church officer's house, to cost £300; also halls, vestry, managers' room, &c., to cost £2,000; total, £7,200.

A special meeting of the Tewkesbury Corporation was held on Monday, under the presidency of the Mayor, when it was resolved that Mr. W. H. Gray, the surveyor, who has been missing since Saturday, be discharged from the appointments held under the council. It was also resolved to advertise as vacant the appointments of surveyor and inspector of nuisances until May next, when the annual appointment is made, at a salary of £100 per annum, but the proposition was withdrawn. The finance committee was empowered to perform the duties of surveyor, and Mr. Leicester, chartered accountant, of Worcester, was appointed to audit the borough accounts. Mr. W. H. Gray has been borough surveyor of Tewkesbury for the past twenty-five years.

**HAM HILL STONE.  
DOULTING STONE.  
THE HAM HILL & DOULTING  
STONE CO.**

Incorporating THE HAM HILL STONE CO. and C. TRASK and SONS (THE DOULTING STONE CO.)

Chief Office: NORTON, STORE-UNDER-HAM, SOMERSET.  
London Agent: Mr. E. A. WILLIAMS, 16, CRAVEN STREET, STRAND.



**BILLS OF QUANTITIES, PLANS, &C.**

Lithographed in best style and with great expedition by  
**PARTRIDGE & COOPER,**  
ARCHITECTS' AND SURVEYORS' LITHOGRAPHERS,  
191 & 192, Fleet St., and 1 & 2, Chancery Lane,  
London, E.C.  
Special Prices quoted for Large Jobs.  
LIBERAL DISCOUNTS ACCORDING TO ARRANGEMENT.

**FAMBRINI & DANIELS,**  
MANUFACTURERS OF IMPERISHABLE CONCRETE  
MASONRY FOR  
**CORNICES, STRING-COURSES,  
MODELLED PANELS, AND EVERY  
STONE-WORK REQUISITE.**  
LANDINGS and Plain or Moulded and Mitre  
STEPS, durable throughout.  
WORKS AND OFFICES: LINCOLN.

**PILKINGTON & CO.**  
(ESTABLISHED 1838),  
MONUMENT CHAMBERS,  
KING WILLIAM STREET, LONDON, E.C.

Registered Trade Mark:  
**POLONCEAU ASPHALTE**  
Patent Asphalte and Felt Roofing.  
ACID-RESISTING ASPHALTE.  
WHITE SILICA PAVING.  
SEYSSSEL ASPHALTE.

**WM. OLIVER & SONS,  
MAHOGANY, WAINSCOT, WALNUT,  
TEAK, VENEER, and FANCYWOOD  
MERCHANTS,**

120, BUNHILL ROW, LONDON, E.C.  
The most extensive Stock of every kind of  
Wood in Planks and Boards, dry and fit for  
immediate use.

**TENDERS.**

\* \* Correspondents would in all cases oblige by giving the addresses of the parties tendering—at any rate, of the accepted tender: it adds to the value of the information.

**BARKING.**—For shops at Barking. Mr. F. S. Hammond, architect:—  
Lark and Son ... .. £5,096 0 0  
Shurmur ... .. 5,015 0 0  
Johnson ... .. 4,992 0 0  
Gibb ... .. 4,400 0 0

**BETHNAL GREEN.**—For erection of the Cornwall Arms p.h. and two cottages, Bethnal Green. Mr. W. J. Ingram, architect:—  
Maxwell Bros. ... .. 2,556 0 0  
Parson ... .. 2,430 0 0  
Rowe ... .. 2,410 0 0  
Higgs, F. and F. H. ... .. 2,370 0 0  
Ling ... .. 2,338 0 0  
Whitehead ... .. 2,325 0 0  
Beer and Gash ... .. 2,297 0 0  
Shurmur, W. ... .. 2,294 0 0  
Barker ... .. 2,249 0 9  
Courtney and Fairburn ... .. 2,117 0 0

**BOSTON, LINCOLNSHIRE.**—For the supply of granite, for roads committee of the Holland County Council:—  
Boston division (2,150 tons):—  
Quenast Co., Belgium (accepted), 9s. per ton.  
Sutton division (1,280 tons):—  
Groby Co., Leicestershire (accepted).  
Spalding division:—Groby Co. (accepted).

**Bow.**—For erection of new rectory at Bow. Messrs. W. A. Hills and Son, architect:—  
Mowlem, J., and Co. ... .. £2,791 0 0  
Robey, J. T. ... .. 2,700 0 0  
Woodward and Co. ... .. 2,620 0 0  
Perry and Co. ... .. 2,596 0 0  
Downs, W. ... .. 2,588 0 0  
Salt, S. ... .. 2,577 0 0  
Shurmur, W. ... .. 2,493 0 0  
Sheffield Bros. ... .. 2,347 0 0

**HOMAN & RODGERS,**

ORIGINAL PATENTEES OF ALL GIRDERS **ENGINEERS,** FORMED OF JOISTS AND PLATES.  
CONSTRUCTIONAL STEEL SKELETON BUILDINGS (AMERICAN SYSTEM).  
FIRECLAY BRICK FLOORS, ALSO CONCRETE FIREPROOF FLOORS.  
USED IN OVER 2,000 BUILDINGS



ROOFS.  
BRIDGES.  
PIERS.

GRANITIC  
PAVING  
STEPS.  
ASPHALTE.

SECTION OF BRICK FLOOR.

**LONDON** { OFFICES: 17, GRACECHURCH STREET, E.C.  
WORKS: NINE ELMS LANE, S.W.  
Telegraphic Address, "HOMAN RODGERS, LONDON." Telephone No. 1026 Avenue.

**MANCHESTER** { OFFICES: 10, MARSDEN STREET.  
WORKS: WEST GORTON.  
Telegraphic Address: "NAMOH, MANCHESTER." Telephone No. 637.

FIRECLAY BRICK WORKS:—PARKSTONE, DORSET.

**COPPER ROOFING.  
ZINC ROOFING.**

SOLE INVENTORS and PATENTEES of SOLID STOPPED ENDS, &c.  
NO EXTERNAL FASTENINGS. NO SOLDER.

**F. BRABY & CO., L<sup>D</sup>.**

352 to 364, EUSTON ROAD, LONDON, N.W.  
Branch Office:—ASHTON GATE WORKS, CORONATION ROAD, BRISTOL.

# THE BUILDING NEWS

## AND ENGINEERING JOURNAL.

VOL. LXXIV.—No. 2253.

FRIDAY, MARCH 11, 1898.

### CRAFT INDEPENDENCE.

THE engineer and architect are often brought into close relationship; but for certain reasons, obvious and otherwise, they still retain their individual preferences—that is to say, the wall of separation is not easily broken down, and a sharp line appears to divide the two vocations. One of the strongest reasons for this separation is probably the fact that both must live. It would hardly do for architects to invade some of the fields of the civil engineer—hydraulics, sewerage, or railway engineering, though in ancient times and the Middle Ages they did so; nor, on the other hand, would it be agreeable, or, in the nature of things, right, for the engineer to pose as a designer of buildings, domestic or public. Things have changed so much that an engineer's idea of architecture would, we fear, be rather "mixed," or, shall we say, too decidedly prosaic to suit most people. And yet it has been asserted by a good authority on the history of architecture, that the modern engineer's work is a great deal more entitled to be called real architecture than that of the architect; in short, that the engineering work of the age is nearer to the true spirit of the art, as being an embodiment of our requirements. That honest construction, which expresses every function directly without disguise or concealment, is the basis of good architecture must be conceded, and in this respect the engineer sets an example to the ordinary architect, who is content to adopt a style or to imitate a leader. But there is an element in design which the engineer has not as yet been able to discern, and that is human sympathy, or that element of pleasurable emotion so necessary to a work of art. If he could only understand or appreciate this desire, his work would be real architecture. For the lack of this, his designs fail to commend themselves to the popular eye. They are hard and unappreciated. And the modern engineer is in no mood to satisfy this longing; he prides himself on his science and technical skill, and rather exaggerates the qualities of mechanical cleverness and magnitude. This is probably one of the reasons why his relation with the architect is not the pleasantest.

Let us take, for example, one kind of engineering work which is closely connected with the design of the architect—structural ironwork of a commercial kind. It is most likely the architect's design has been made without reference to a particular estimate. The engineering firm have to tender for the work to be done, and are required to prepare their own quantities and specification as well. Virtually, the architect leaves the matter in their hands. There are wrought and cast-iron columns or stanchions, wrought-iron girders, fire-proof floors and roofs—matters involving calculation of loads and stresses. The architect rids himself of the responsibility to some extent, but at a serious sacrifice of architectural solidity or merit. The manufacturer is unwilling to learn anything beyond his pattern-book, and the sections which give the greatest strength at the least quantity of metal. With him everything is weight. The architect specifies certain sections of columns, of stanchions, and iron joists; but the details of workmanship, about which he knows very little, are left to the manufacturer. The effect of these conditions is to make the architect dependent

on the manufacturer, and for the latter to dictate the details of the work. Of what use is it for the architect to make designs and working drawings of certain ironwork, and find that the iron merchant is not willing to tender on those drawings? The latter knows that iron construction must be used, and is master of the position, and does much as he likes. Special designs of the architect can stand little chance against the market prices and patterns, which crowd the catalogues of the modern tradesman.

We have been speaking of constructional ironwork; but for ornamental wrought-iron work the architect has it all his own way. That there is something inconsistent with the treatment of the material goes without saying. The principle of hammered work is sometimes lost sight of, and very ornamental designs are made quite out of character with the material. In this branch of craftsmanship the architect may yet learn something. Then we have leadwork, about which Mr. F. W. Troup, A.R.I.B.A., discoursed the other day at the Architectural Association. Who that has been to any of the old French, German, and Flemish cities like Bruges can have failed to see what an important detail ornamental leadwork was? The Mediæval architects relied much on it to give point to their buildings, as wrought iron was used to decorate brick fronts. Mr. Troup's remarks, which we reported last week, are of interest as pointing to the durability of cast over milled lead in roof-work; its superiority for ornamental work, for pattern embossing; the harder quality of old over new and purer lead from which all other metal, like silver, tin, iron, &c., are abstracted; the excess or misuse of soldering in modern leadwork and overclose dressing of lead over woodwork. The remarks on the proper ornamental treatment of lead in pipe-heads, coffers, cisterns, spires, finials, and ridges, many examples of which Mr. Lethaby has given us in his recent work on "Leadwork," ought to be taken to heart by architects who have too long left lead and all its works in the hands of plumbers. No doubt the reason is obvious: architects have not taken the trouble to learn the capabilities or possibilities of the material; they have so long been associated with stone and stucco and wood that all other materials have been allowed to remain in the hands of engineers and plumbers. And so it is with other trades: they have become mechanical simply because architects will not master them or the materials. Structural engineers, plumbers, and smiths work in them without any feeling or sympathy. All freedom in treatment is gone; the workman tries to follow the architect's design line for line, but in so doing the whole spirit is lost. Even workers in iron and lead know how impossible it is to give the architect's meaning, or to produce a particular detail or effect.

In sanitary work, again, the architect has to give in much to the engineer and plumber. It would be simply impossible to expect the architect to know perfectly the technical details of a cooking apparatus, or even to specify the requirements of a large hotel in detail without consultation. Then, again, with the heating engineer, the trade is left to the specialist—who takes care to keep in his own hands the systems of heating buildings. Nor would we expect an *entente cordiale* between the architect and the mechanical and hydraulic engineer, or even between the horticultural engineer and electrician all of which branches of engineering are now separate and distinct crafts which have no reference to architectural design. Yet they hamper and impede the designer of a building. Each has its own rules and trade regulations, which generally conflict with the architect's notions; each has its own conventions and modes of treatment, and to try to bring them to any common understanding is an impossible task. With

every invention and building improvement the architect is brought face to face with a new form of engineering which he has to boldly meet or compromise with. Discretion is often the better part of valour, to find a solution and try to reconcile what seems irreconcilable. Exceedingly distasteful and obnoxious it must be for an architect to give up his solid moulded wood beams for fire-proof casings of metal lathing and plaster, or to study the electrician's requirements before he designs his wall decoration and ceilings, or the ventilating engineer's exhaust shafts; but it is better to make room for them quietly than to fight against the inevitable. The demons of cheapness and fashion are the greatest enemies to the architect, and these can only be vanquished when he learns to win them over by timely concession.

### MODEL SPECIFICATIONS.—III.

#### EXCAVATOR AND DRAINAGE.

THE clauses we have given for the Excavator are those which apply to ordinary buildings; but, of course, there are special circumstances in certain cases. It is usual in clauses for excavations to name some distance for removal of soil or earth—usually 20 yards; if it is wheeled beyond this distance, it is desirable to state how much. Also if the excavation is deeper than 5ft. or 6ft. Upon these data the charge for carting, &c., mainly depends. In most trades, as we have remarked, there is a general sequence, and the clauses we give will generally begin with the simpler and commoner kinds of work, and then proceed to the more complex. In this particular trade the earlier clauses relate to superficial digging, as taking off the top soil not exceeding, say, 12in. in depth over the whole site; then to deep excavations for basements, for which timbering to support the sides of the excavation may be necessary; and the same difference is observed between digging and carting to trenches; and digging, filling, and ramming, a portion of the earth being left and returned for the latter purpose.

Much may be said on shoring, strutting, and waling to the sides of trenches and excavations; but the reader is referred to the handbooks on building construction. We show two sketches of ordinary trench-work. In every case it is necessary to describe the nature of the soil—whether clay, loam, gravel, sand, &c., as upon it the necessity of strutting, &c., entirely rests. In well-drained land, earth will stand in embankments about 1½ to 1.

For large excavations, steam excavators are employed, and a 10-ton locomotive steam crane excavator with 1½yd. digging bucket is stated to excavate and deliver into waggons from 800 to 1,200 cubic yards per day of 11 hours, according to nature of ground.

#### DRAINAGE.

The subject of drain-laying comes under the general head of "Excavator." It is necessary for the specification writer to understand the modern system of sanitation and pipe-laying. In this system the "disconnecting manhole," or "access chamber" as it is sometimes called, is an important detail. We refer the reader to many of the sanitary handbooks on this subject, and confine our attention to a few details. Practice varies as to the mode of construction of manholes, but there are a few points to be observed. Some authorities say that the "disconnecting manhole" should be at a distance of about 70ft. or more from the house; but this is impossible in ordinary buildings in towns and suburbs, and the manhole is generally placed a few feet from the house, the chief consideration being that it intercepts or disconnects the main sewer from the house drain, and is built at the house end of the siphon trap. The chamber may be for ordinary houses about 3ft. square

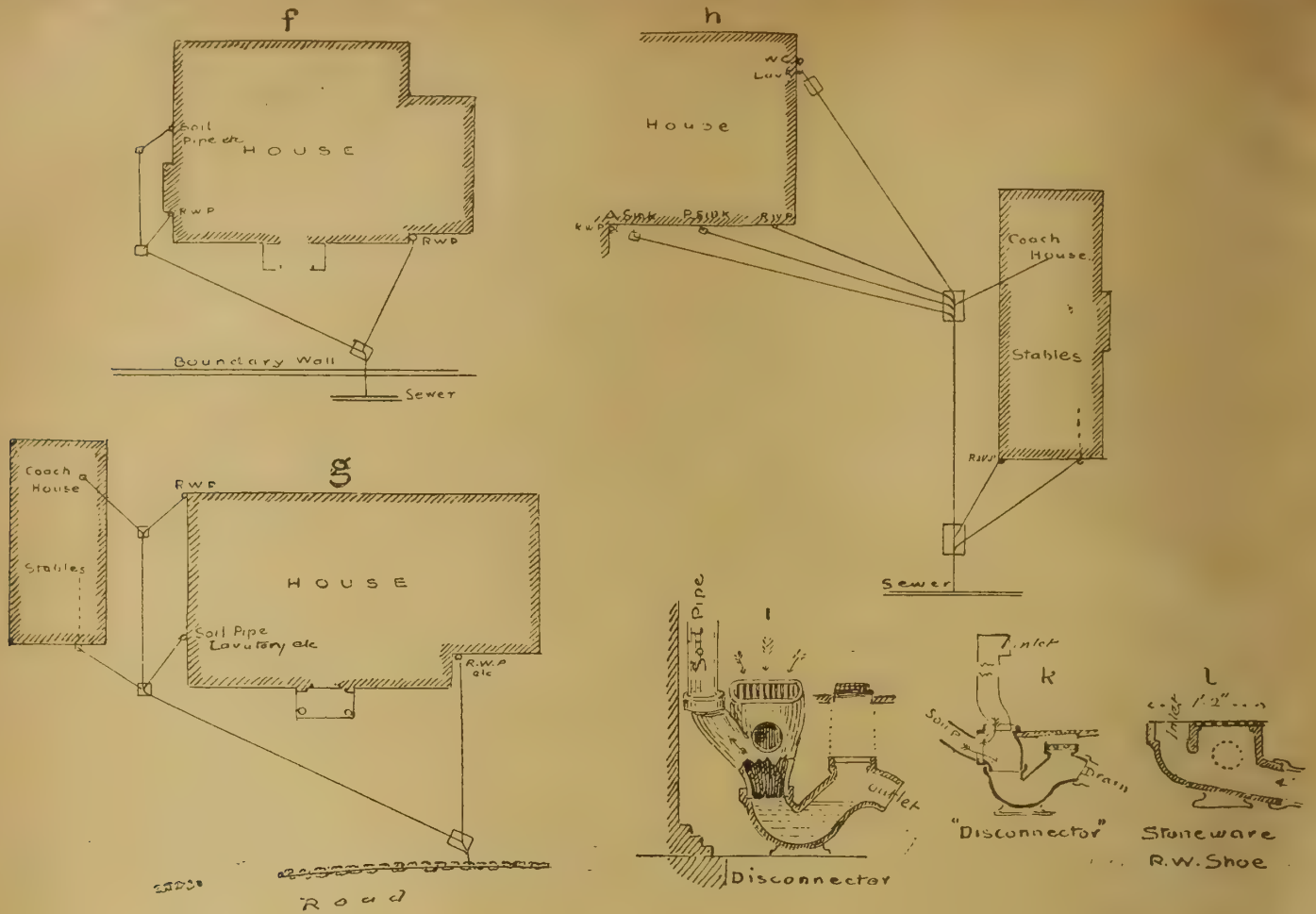

or 3ft. by 2ft. (see sketch C), and be built of 9in. brickwork, finished with cement, the walls and chamber being laid on a bed of concrete. A straight, open, half-pipe or white glazed channel of stoneware is laid in this concrete bottom, bedded in cement on the socket of siphon-trap (see sketch C, last week). On either side branch pipes from the wastes and other pipes may be made to join it at an easy angle or curve, discharging also through

cemented or faced with glazed bricks, and an iron airtight cover put over the manhole. The detail is shown in our sketch (p. 296). The house-drain, by which we mean the length of drain between the soil-pipe foot and the "disconnecting manhole," as distinguished from that from the latter or siphon-trap to the sewer, or "connecting drain," should be laid in a straight line from first inspection chamber to the disconnecting manhole; or if it must be in two lines, it should be laid straight to the "turning chamber" and thence to the disconnecting manhole (see plan b, p. 296), so that the house-drain can be cleared from the latter. If the house-drain passes under the house, as in town houses, it should be quite straight, and be bedded in concrete at least 4in. in thickness; no branch drain should be connected to it. Whenever a change of direction in the drain is required, a turning manhole should be made at that point, and an open glazed channel must be laid in it (see c, p. 296). The 4in. house-drain should be laid to a fall of 1 in 30, a 6in. drain to a fall of 1 in 40, and a 9in. to a fall of 1 in 60. The connecting drain between disconnecting chamber and sewer is determined by the length and depth of sewer. We give plans of drainage for country villas and stables (sketches f, g, h) which explain themselves, and disconnecting traps for soil-pipes instead of manhole as described. K shows a good form of trap in lieu of disconnecting manhole; C is a R.W. shoe for the feet of rain-water pipes, &c.

tion cast on the spigot is spherical, and allows a slight deflection to take place. The concentric fitting secured by the "Stanford joint" and the "Tyndale" patent, a double-seal joint, the "Patent Paragon," "Sykes" screw joint, have each merit. If cement joints are used, they should be wiped out as the work proceeds.

The Local Government Board By-laws provide that there shall be on the line of

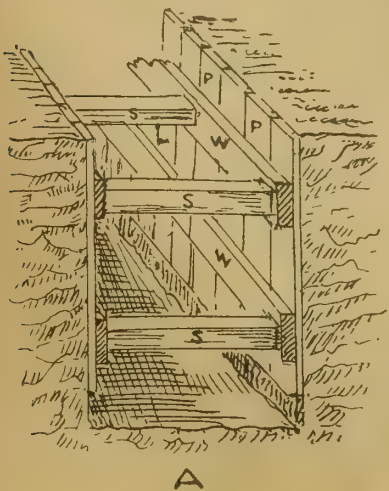

W, Walings; P, Poling boards; S, Struts.

open glazed stoneware channels into the main central channel, so that the drains leading from them may be cleared if any stoppage occurred. When these half-pipes, or glazed open channels, are laid, the concrete should be made up round them on each side, battered up to the chamber walls on three sides, and the surface smoothly rendered over with cement, made flush with the inner surfaces of the channels. The walls are also

True gradients must be observed from chamber to chamber, and these, if for inspection or disconnection, should be about 2ft. by 3ft., their depth varying according to circumstances, and have, as said above, open-channel inverts and fresh-air inlets. For jointing pipes, several patent self-adjusting arrangements for uniting the spigot and socket ends are in the market. Doulton's "self-adjusting joint" leaves little to be desired, as the composi-

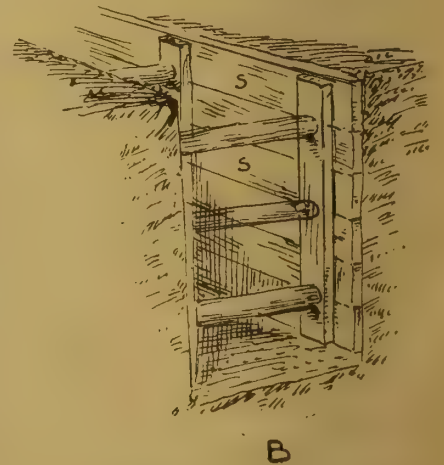

S, Sheeting; P, Poling boards.

each drain "two untrapped openings," one opening being on the house side of the disconnecting trap, and the second on the top of drain or soil-pipe end.

Notice should be given to parish and other authorities for connecting house-drain to sewer, and the drains should be left open for the inspection of local authorities.

**Maxims in Drain Laying.**—All junctions should be made at a manhole. Main pipe-drains should be laid in straight lines, and have gradients from manhole to manhole.

All junctions should be made with a curve. Drains of unequal section or diameter should not join with level inverts; the lesser should have a fall into the larger equal to the difference in the diameters. A ventilating pipe from the interceptor trap, just where the drain enters the house, should be provided in order to disconnect sewer gas from house, and this should be carried up to the roof level, finished with a cone or one of Boyle's extractors.

We may name a few intercepting traps well known in the market:—Mansergh's external house protecting drain-trap with iron grid; Weaver's ventilating sewer air-trap; Sykes's patent sewer-gas interceptor, with fresh-air inlet and sewer-gas outlet, and inspection inlets with screw stoppers; Jennings's ventilating cesspool traps; Hellyer's patent ventilating drains, siphon, and sewer interceptor; also his combination drain-trap or disconnecter with galvanised cast-iron gratings; Wanser's intercepting sewer-trap; Hayward's airtight inspection-covers to drains. (Plans *b, f, g, h, &c.*, illustrate these traps.) The following are the usual clauses for drainage:—

1. *Drains.*—The drain-pipes to be the best (or salt glazed stoneware socketed pipes of approved make (or Doulton's "tested"), hard, sound, perfectly straight, cylindrical and smooth inside, and free from flaws, with all bends, tapers, junctions, and other connections, and to be laid in straight lines to regular falls from the soil and waste R.W. pipes to the inspection and disconnecting chambers, as shown on plan (see *b, f, g, h*). The pipes to be of the following diameters: the main house-drain from soil-pipe to disconnecting chamber to be 6in. internal diameter, and of about 2ft. lengths; and the other branches from wastes and sink to be 4in. pipes.

*Testing.*—The contractor will be required to test the drains in the presence of the architect or clerk of works by filling them with water, proper plugs and other necessities being provided for the purpose, and the drains are not to be covered in till this has been done and approved.

*Cement Joints.*—The pipes to be jointed in neat Portland cement (or mixed in proportion of one part cement to 3 parts of good, clean, sharp sand by measure), taking care to wipe out the inside as the laying proceeds. They are to be laid (or incased) in concrete 6in. thick (the concrete to be 7 to 1). Form round each joint a fillet of Portland cement 3in. wide. Or—

The drains to be of A form [show section] or B form, laid in a bed of concrete 6in. thick the full width of trench, and the pipes jointed together with Portland cement (or, to have Doulton's or Stanford patent self-adjusting joint). Or—

The stoneware pipes to have Stanford's patent joints. Clean spigot and sockets of pipes, and then apply hot with a brush a preparation of Russian tallow 2 to 3 parts to 1 of resin to the joints; wipe the inside clean, and draw a pad through each pipe as it is laid. A fillet of neat Portland cement to be put round each joint outside.

2. *Bedding in Concrete.*—All drain-pipes under buildings to be incased in cement concrete 4in. thick (or 16in. for 4in. pipes, 18in. by 18in. for 6in. pipes), and the open channels and branches in manholes to be imbedded in concrete sloped down to them.

It should be noted here that the body of the pipe is to be laid on a bed of concrete, the latter being cut out under each collar to allow space to make the joint.

3. *Inspection Chambers.*—Build the inspection chambers, of the sizes shown on plans, of one brick in thickness in cement, with one course of footings on a bed of lime concrete 12in. thick, and overall top courses if necessary. Form concrete bed to receive centre open channels and branches, as shown in sketches C and E.

*Disconnecting Manholes.*—The disconnecting-chamber to be built, as shown (sketch C) on plans, with Crapper and Co.'s "Improved Kenon" trap (or other approved siphon with sweeping arm and caps set in mortar), and 6in. fresh-air inlet. The interior to be lined with 4in. brickwork in cement, (or to be cased with white glazed bricks). The bottom to be of cement concrete, in which are to be bedded in cement Crapper and Co.'s (or Doulton's or Duckett's) enamelled stoneware channels and bends. The surface of concrete to fall towards the open channels, and to be rendered with Portland cement to a smooth surface. Cover manhole with Crapper and Co.'s (or Hellyer's)

galvanised-iron air-tight covers set in cement of the size shown. Or—

Execute the brickwork to manholes and chambers with stock bricks (or glazed facing bricks) laid in cement mortar on footings upon cement concrete foundation. Point the brickwork on both sides as the work proceeds. Or—

Build disconnecting manhole 3ft. 6in. by 2ft. 6in. in 9in. brickwork on proper footings upon cement concrete foundation over the whole area. Insert at the outlet end a (one of Doulton's, Field's, or Duckett's) 6in. stoneware siphon intercepting trap with 4in. cleaning branch and cap. Bed in concrete 6in. white glazed half-pipe and 4in. half-pipe bends, as shown; form the sides and benches in concrete, and render in neat cement. Put a 6in. air-inlet pipe where shown, and cover manhole with a 2ft. by 18in. cast-iron cover and frame with indiarubber seating, let into York curb.

The open channels or half-pipes should have a fall of 3in. in their length, and the sides should be formed up in concrete some inches above sides of pipe, and the benches should be sloped and rendered in neat cement.

We have given several different specimen clauses. Very often in the case of ordinary houses a cheaper plan is to have a disconnecting trap only, without the chamber, and many of these are in the market. Doulton, Dent and Hellyer, Duckett, and others manufacture excellent intercepting traps, two or three of which we illustrate. We may provide any of these as follows:

4. *Disconnecting Traps.*—At the foot of bath, lavatory, and sink waste insert one of Dent and Hellyer's "Waste Receivers" (or Doulton's). Or—

"Disconnecting" traps as shown on sketch, bedded in concrete with iron grid. Or—

The soil-pipe to have at the foot one of Dent and Hellyer's "Combination" or "Disconnecter" traps as shown *i* and *k*, with galvanised iron grid 9in. long, and loose stoppers for stopping holes. The trap to be bedded in concrete, &c.

5. *R. Water Shoes.*—Put at the foot of every rain-water pipe one of Dent and Hellyer's (or Doulton's) patent stoneware shoes (see sketch *e*) bedded in concrete, with a 9in. by 9in. close plate cover, let into a rubbed or tooled stone curb.

*Grease Trap.*—Put one of Doulton's (or Hellyer's or Wanser's) 12in. flushing gully, bedded in concrete (see sketch). The flushing tank (if any) to discharge into this gully. Provide iron grid on stone curb.

(Note.—When the trap is deep a pipe shaft for ventilation can be brought up to level of ground; the inlet has a perforated top.)

Or the following clauses may be used:—

Put Duckett's automatic grease collector and flusher with four-gallon tipper to all sink wastes.

Put one of Doulton's patent "gully channels" for waste-pipe from sink or bath with wire cover set in cement concrete where shown.

6. *Gully Traps.*—Several sorts of gully traps are patented. The clauses for these may run:—

The gullies to be Doulton's yard gully (or Hellyer's R. water interceptor) with 4in. inlet for rain-water pipe, with 8in. square top, bedded in concrete 4in. thick. Or—

Provide Doulton's (round or square) yard gullies, with bend for rain-water pipe bedded in cement. Or—

The gullies at the feet of waste pipes to be Duckett's patent "self-cleaning channel," and those for rain-water pipes to be the same maker's trap and dish-brick with hinged grate. Or—

The gullies to be of an approved kind with galvanised iron grids, fitted in rebated York curbstones, with 4½in. brick-built pits in cement of the necessary depth, rendered inside with cement.

*Bed in Concrete.*—The feet of all soil, rain-water, and other vertical pipes to be bedded in concrete, and be connected in a manner approved to all traps.

To prevent evaporation of seal, a gully-trap should have a sink-waste discharging into it. In dry weather this prevents the evaporation of water, and it is desirable when there is no manhole that it should have a cleansing branch and cap, as shown in sketch.

Referring again to disconnection of house-drain from sewer, a 6in. pipe shaft—such as Hellyer's—can be carried up from the drain-trap, which may be at some depth, and terminate with a suitable inlet for admitting fresh air to the house-drains. Many stoneware traps are made with an open head for continuing such pipe-shaft upwards, and

having another opening or inlet, which can be turned to any direction for a branch to enter. The inlet is generally made in a separate piece to the body of trap.

Sometimes it may be necessary to insert a clause of a general kind, thus—

7. *General Clause.*—All the glazed stoneware drain-pipes, interceptors, and gullies to be Doulton's (or Duckett's, &c.), to have Doulton's (or Stanford's) self-adjusting joints or "composite" joint. Insert at every bend or junction Doulton's patent junction or access pipes, with stoneware covers; and at all manholes lay in concrete channel-pipes, the joints between the channel-pipes and brickwork to be carefully made in cement (or Doulton's "Registered channel-pipe" to be used), &c.

#### ARCHITECTURE AT THE ROYAL SCOTTISH ACADEMY.

THE seventy-second exhibition of the Royal Scottish Academy, recently opened, has 799 exhibits, which is a somewhat bulkier collection than that of the year preceding, owing, doubtless, to the smaller number of large pictures and portraits. The arrangements are the same as for a few years past, and everything has been done to improve the appearance of the rooms and make them attractive in every way to the public. The loan department does not contain any such interesting pictures as those of last year by the late Sir J. Millais, and there is no picture of such outstanding interest as to be likely to attract a crowd. The water-colours are in the South Room, as before, and architectural and other etchings are in the small octagon. 642, by R. B. Johnston, is the perspective of the interior of the Baptistery of Siena Cathedral, which gives an excellent idea of the building and its decoration, mostly in blue and red. The font is an imposing structure, more in the style of the memorial fountain, the basin being a large octagonal pouch, with plain structural detail, but elaborate carving on its panels, and from the centre rises a lofty octagonal turret and spire. 660, "The Old Tolbooth, Kirkcudbright," by Marian Ancrum, shows an old Scotch tower with corbelled parapet and high flight of steps to give access. The rest of the building to the street is commonplace. 717 is a very nice sketch of "A Bit of St. Andrew's Cathedral," by W. Proudfoot. There is not much more than a bit left of the whole, and the one represented is not inconsiderable. It shows the broken surface arceding of the walls of what seem to be the chapter-house. The detail of the Norman architecture is apparently much the worse for weather. 755, "Crathes Castle, Aberdeenshire," by J. G. Laing, is very picturesquely sketched—a small corner of the main building, only visible through a long vista of ivy-mantled walls. The house is of many stories, with old Baronial detail. 765, "A Cloister in Holyrood," by C. P. Ross, is well delineated in the draughtsmanship, but lacks softness and harmony in the colour. 772, "The Enchanted Castle," by James G. Laing, is a very attractive subject, and represents probably, with some imaginative alteration and addition, a real castle. The twilight gloom rests on the landscape, which has a bridge in the middle distance, and a rider with lance crossing to the tower at the other side of the moat or river. The details of the architecture are fanciful; but the well-known Scotch turret plays a good part in the composition.

The Water-Colour Room, as a whole, has not many interesting subjects. 691, "Return to Hawick from Horn's Hole, 1514," by T. Scott, has a crowd of figures on the canvas, all very carefully studied, to represent the parties meeting the survivors of Flodden. The blue blanket has a conspicuous place.

The sculpture has about fifteen subjects. 394 is "Sketch Study for Colossal Statue of James V. of Scotland," for the National Portrait Gallery, by Birnie Rhind. The niche is also modelled, with the carved bracket below, and the figure has a very good presence, and is clad in the proper style of the period; but some other notable might have been more worthy of the conspicuous position assigned to him, who left nothing to mark his history but an untimely death.

The architectural exhibits are not numerous, and the names of some regular exhibitors are conspicuously absent. Mr. Honeyman, Mr. H. Blanc, and Mr. Leiper are the only Associates who are represented, and the only one by Mr. Blanc is 574, "A View of Christ Church,

Morningside," erected many years ago. The drawing is a very fine sepia perspective to a large scale, showing to advantage the somewhat over-elaborated detail of the chancel, and the fine tower and spire which is the feature of the neighbourhood. 558 shows two "Elevations of Designs for Belfast Town Hall," by Messrs. J. Honeyman and Keppie. It is an etching of a large building with extended frontage, and central square with dome. The details are plain Classical, and the drawing is made with very heavy lines, which does not improve it as a picture. The dome looks rather small and pinched, probably from the heavy surroundings at the lower part, or its receding to suit the square structure beneath. 586, "Proposed Restoration of Brechin Cathedral," by the same—view from the north-east—is a water-colour sketch to a good scale, and shows a complete Mediæval church of Early English, with earlier and later developments. The square tower with embrasured parapet stands at the north side of the nave. The clerestory has only a few small lancet lights, but the aisle large triplets, and a north porch with deeply-recessed doorways. The choir or chancel is lofty, without aisles, with parapets and gargoyles and five lofty lancets, and priests' door below them, near the east end. The east gable is treated with octagonal turrets, rising out of massive buttresses. The round tower on the south side is not seen. 592, "Design for Paisley Technical School," by the same architects, shows an extensive Classical front, with large circular projection in the centre, a broad zone of sculptured ornament making up for lack of windows. The details are those of the usual Classic work. 566, "Viewfield, Stirling," for Mr. W. Renwick, by W. Leiper, R.S.A., is picturesque treatment of a large mansion house in the Scottish Baronial style. There is much variety in height of roof and arrangements of plan, with angle turrets of large proportions and dormers. A range of lower building to the left gives dignity to the highest portion of the design, which must have a ground plan of considerable extent. The entrance is in a projection running in line with the front of the principal part of the building, and behind it is a lower building of two floors and the dormers. Mansion houses, large and small, bulk largely this year. 564, "An Architect's House, Ayr," by James A. Morris, shows a long ground plan, with rooms all on one side and passages on the other. It is designed in the half-timber upper-floor style, with red-tile roof, and with very small windows of irregular size, going, indeed, to the opposite extreme, for which buildings in this style are generally notable—viz., their spacious windows. 573, "Proposed Additions to an Old Scotch Mansion," by Messrs. Leadbetter and Fairley, seems to be an extensive addition on one side of a building, and forming a third side, inclosing a square plot. The "auld house" has been a very plain one externally, and the addition could be nothing else to be in keeping. A hall, drawing-room, and entrance appear to have been but ill provided for before. 577, "Eccles, Berwickshire," by the same architects, is a perspective in a different style of an entirely new edifice somewhat in the bungalow style, being a lengthy and low stretch of building of two floors, with deeply overhanging eaves, and hipped or pavilion roofing. The elevations shown are pleasantly relieved by various projections, which completely save the whole from the commonplace aspect of the style. Conspicuous features also, with similar result, are the numerous chimney stacks rising on the front walls, and a large octagonal projection in the centre of same elevation has a happy effect. 575, "Dalskaith House, Dumfriesshire," by J. A. Campbell, is another large mansion, with conspicuous central tower, and other usual details of the Scotch Baronial. 585, "Millhills House, Perthshire: Additions and Alterations," by J. M. Henry, is a building of inconsiderable height in the Scotch style, with corbelled gables. 554, "Briglands, Kinross," by R. S. Lorimer, is an edifice of moderate size, in ground plan in form of an L, with a court in the angle, inclosed with balustrade in front, to which access is had by a handsome staircase down to its ground-floor level. The door is rather close to the re-entering angle, and generally the windows are very irregular in their size and arrangement. It is a plain building of three floors. 570 is a water-colour sketch of "Lady Stair's House, Lawnmarket, as restored for the Earl of Rosebery." The drawing is a faithful perspective of this great improvement to

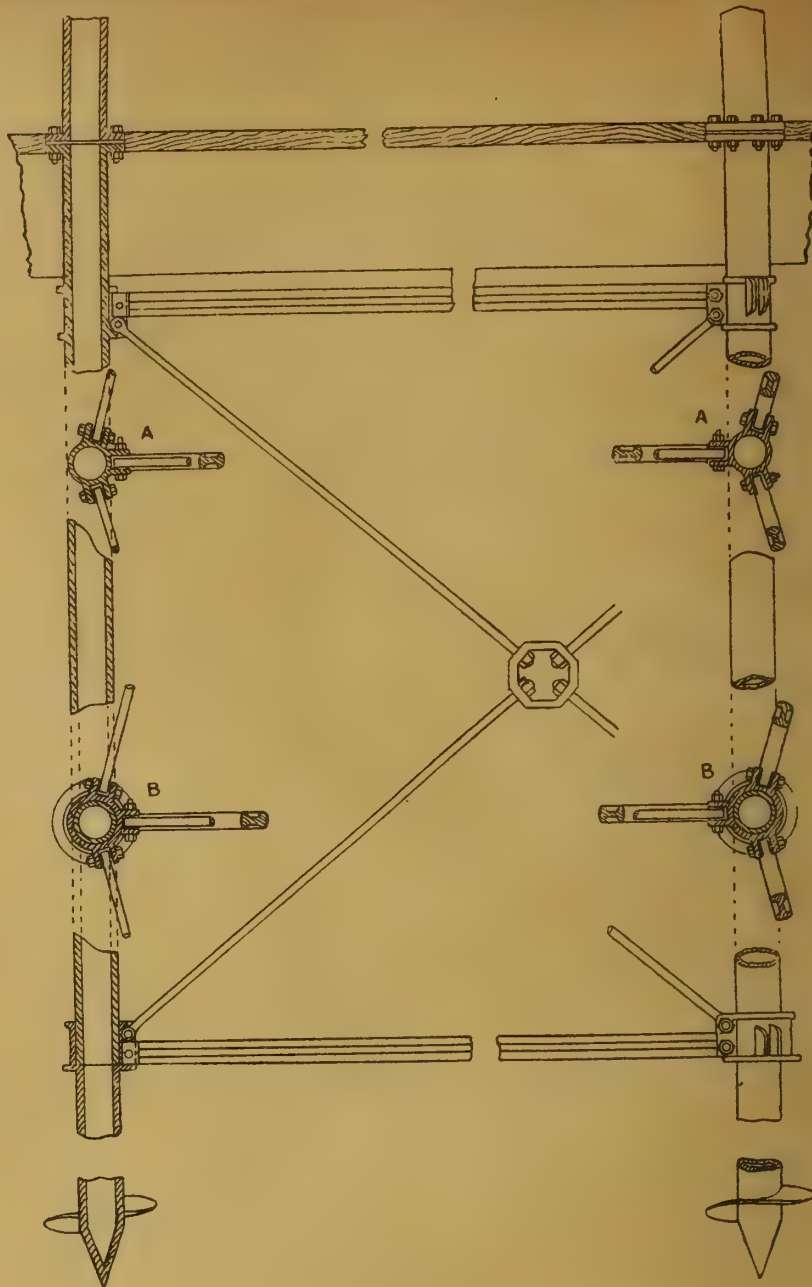

FIG. 234.

the neighbourhood; but it looks too much alone, and the surroundings, which are contiguous, are represented as very far away. 560, "New Printing Works, McDonald-road," by Cooper and Taylor, is a fine specimen of street architecture. 563, "Two Views of Boarding House for Boys at Edinburgh Academy," by A. N. Paterson, is a water-colour, showing a large building of two floors in red stone, building in Inverleith-place. 571, "Premises in Queen-street," by J. Jordan, is also a good sample of street architecture, breaking up the monotony of this old New Town architecture. 572, "Parish Council Offices, Aberdeen," by A. M. McKenzie, is a Classic design, and shows a building of lofty proportions, with large windows, and well-proportioned details. 588, "Duddyston Golf Club-House," by Messrs. Cooper and Taylor, shows a very long elevation, with a sort of square tower about the level of the eaves at one end, a plain pavilion at the other extremity. 543, "Competitive Design for Enlargement of Lerwick School," by J. A. Carfrae, is a small addition evidently to a plain edifice. 555 is the accepted design for Kirkcaldy Burgh School Board, by W. Williamson, jun. This is street architecture, with large circular openings on ground floor, apparently fitted up as shops, with the offices above.

Church designs are very scanty. 559 is a water-colour of "Mayfield U.P. Church in Fountainhall-road," by J. E. Fawley. It is drawn to a very large scale, and is evidently a design with nave, transepts, and shallow passage

aisles. But it seems of good proportions as to length—in Early Gothic style—with rather much in the way of heavy buttressing, to make up, perhaps, for the absence of the spire. 587, "Proposed Free Church, Thornton, Fifeshire," by W. Williamson, jun., is too like a parish hall, with lintelled and Gothic windows. 569, "Proposed Decoration in Marbles of the Jesuit Fathers' Church in Lauriston," by E. A. McPherson, is a masterpiece of interior perspective and colouring. The chancel of this church has been enlarged, and it cannot any more be quoted as an example of the want of architectural taste for which most of the Jesuit churches are noted.

#### WROUGHT-IRON AND STEEL IN CONSTRUCTIONAL WORK.—XXXIV.

THE introduction of cast iron to any important extent into wrought-iron and steel structures is generally deprecated, and it is therefore employed in a much less degree than formerly. Even for struts, for which it is well fitted, it has been mostly discarded; and though once much used to effect the union of the bars composing iron roof-trusses, its place is now taken by pieces of plate, angle-irons, and other sections. There is yet, however, a considerable margin for the employment of cast iron in some minor details. The general methods by which the malleable work is attached to the cast may be considered in this article.

It must be laid down as a rule, to which there

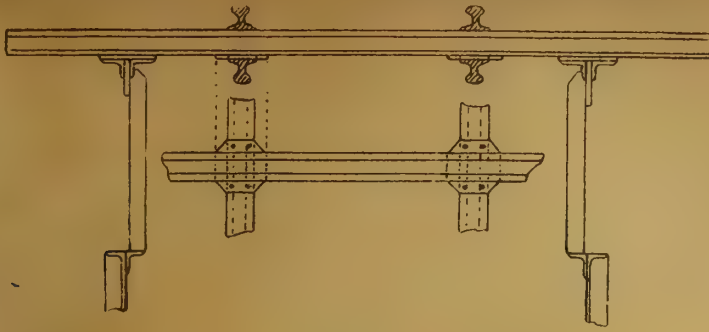

Fig. 235.

are few exceptions, that any method of attachment should not put the cast metal into tension. When this is unavoidable, then very ample margin must be made, and this means the employment of unsightly masses, ill in harmony with the light appearance of the main structure.

Another point is, that rivets are not suitable means of union between wrought and cast iron.

In parts which are sensibly affected by differences in temperature, rigid cast-iron connections are quite unsuitable, unless means of affording compensation are adopted. Provision for expansion and contraction in steel work does not seem necessary in any constructional work except long bridges. Provision is not usually made in the case of roofs, even though of large span.

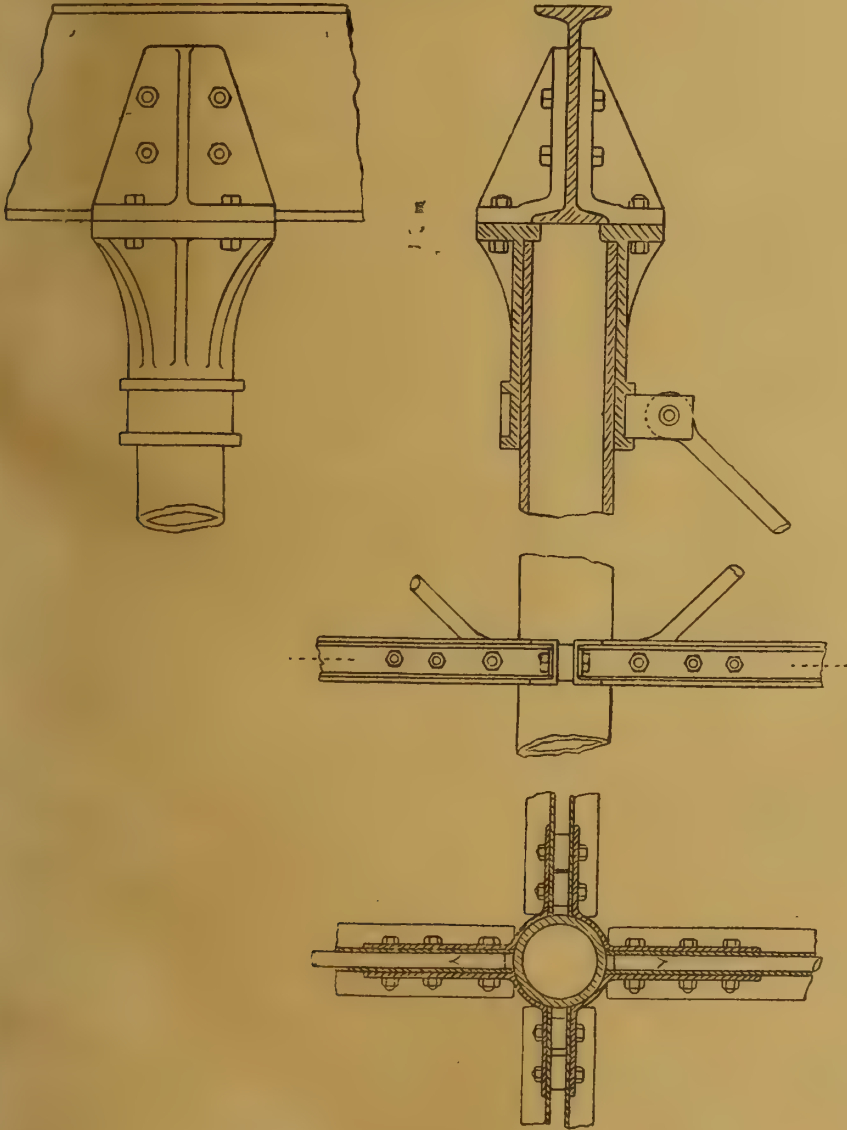

Fig. 237.

The closing of the rivets is likely to fracture the latter, especially when holes come near edges and corners. Only in the case of thick castings, of over, say, 1 in. or 1 1/4 in. in thickness, can rivets be employed with safety.

The place of cast iron is in sections which are not subject to severe stress, or in parts where the stresses are compressive only or principally, and in the case of light details of a rather intricate character, which would be troublesome to form by building up in plate and angle or other sections, and, of course, in large masses. All these occur in many classes of constructional work.

When cast-iron lugs are used as attachments for wrought-iron eyes, tight fitting must be avoided. The conditions are different from those which attend the union of malleable metals, or of cast metals united closely together by turning or planing. In the union of iron and steel plates and various sections, the closer the fit the better, consistently with the erection of the parts. Thus a turned pin fits in its drilled hole just easily by a difference, say, of one-fiftieth of an inch only. The faces of eyes are given only sufficient clearance with the faces of the members which they connect to prevent risk of having to file or plane

the faces in order to permit of their insertion. In riveted work it is stipulated that the rivets shall fill their holes; but in fitting eyes between cast-iron lugs, the contact both of the eye and of the bolt or pin should be quite easy. The difference is due to the characteristics of the metals. The malleable metal will readily yield sideways to any slight diagonal strain, and the driving-in of rivets will not twist it. The cast metal will fracture if a tie-rod brings a moderate side pressure upon it, and the driving of a bolt or pin tightly will crack it. Fig. 234 illustrates the clearance between the lugs and rods, and

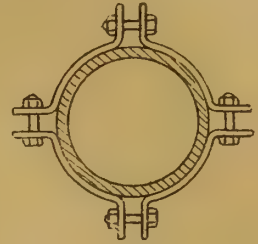

Fig. 236.

1/8 in. is not too much to allow in slack fits such as these.

One of the reasons why lugs of cast iron are distrusted is that there is often a risk of their not being sound. Though ample tensile strength may be allowed, yet half of that may be lost by reason of unsoundness. This may be due to several causes, which I explained at length in a previous series, and need not repeat. The principal underlying causes are the facts that these lugs project from the main body of the casting, and the bolt-holes are generally cored—two facts which, unless particular care is exercised in the foundry, contribute to produce unsatisfactory results.

Fig. 234 illustrates the bracing of the screw-piles which support the pavilion on the Southsea Pier. In this case cast-iron lugs are used for the attachment of the bracings—a method not to be commended, and which would be inadmissible in many situations. But the piles are only 14ft. 6in. apart, and the horizontal bracings and the diagonal ties are so rigidly united that there can be little risk of excessive tensile strain coming on any one pair of lugs. The details of the fittings are clear from the drawing. The whole of the ironwork is below water, and there are two circles of piles, connected with horizontal and diagonal bracings. The adjacent piles in each series are connected with bracings formed of old rails inclosing duodecagonal figures. At AA BB plan sections are given of the upper and lower bracing attachments.

The employment of old steel rails utilised here

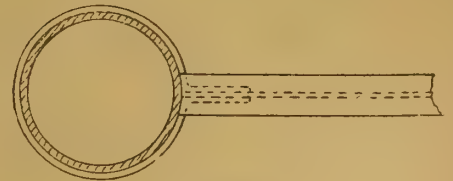

Fig. 238.

is not infrequent: its merit being cheapness. But there is no sacrifice of efficiency, and the practice is therefore to be recommended in many cases. Another example of the use of such rails is shown in Fig. 235, in which the cross-girders and rail-girders are formed of old rails.

Generally, straps of steel or wrought iron are made to encircle the smaller cast-iron pillars, for the attachment of tension rods. In the larger pillars gusset brackets are mostly employed. Fig. 236 illustrates an encircling strap made in four parts for the attachment of four tie-rods. For three rods it would be in three parts, for two in two, and for one either in two parts or a single piece bent round. These are the most common forms.

Fig. 237 illustrates the method of attaching horizontal and diagonal bracings to the piles of the Southampton pier. The former are of channel irons placed back to back, with cast iron distance pieces, 1 1/4 in. thick between, through which the connecting-bolts pass. Wrought-iron straps fitting between the flanges unite these channels

to the columns. The vertical bracings are of round iron, with flat eyes bolted to the straps and horizontal channels, as shown.

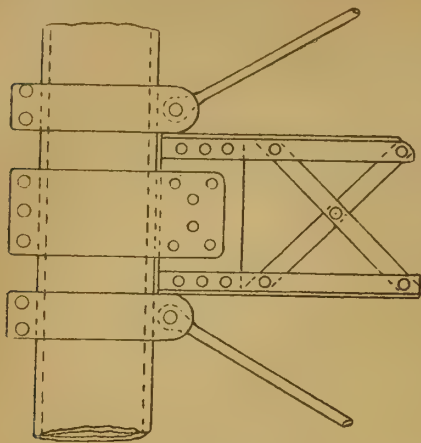

FIG. 239.

At the top of the pile the union of the main girders to pile-heads is shown. Cast-iron brackets or chairs are the means employed—a case in which a rigid fixing is made by the use of cast iron, at

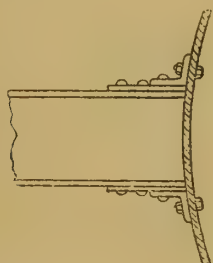

FIG. 240.

a lesser cost than would be incurred by the use of brackets of plate and angle.

Strap attachments are suitable for the heavier



FIG. 241.

as well as for the lighter bracings. Fig. 238 illustrates girders 9 in. by 6 in. attached to cast piles 2 ft. 6 in. diameter, with straps 8 in. by

5 in. Light lattice girders are fastened to cast columns by means of straps, Fig. 239. In such a case a wide plate is riveted next the end of a girder, instead of a narrow vertical, and the strap is riveted to this. Fig. 240 shows H-iron bracings of large cast-iron piles. Here gusset

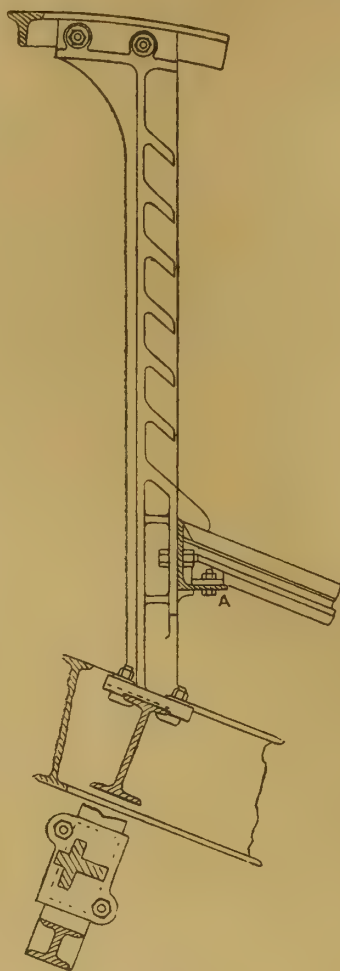

FIG. 242.

plates and angles are employed instead of straps, because of the large diameter of the pillars.

When columns are built up of rolled or Phoenix section, attachments can often be made to the flanges. If the flanges are not sufficiently wide,

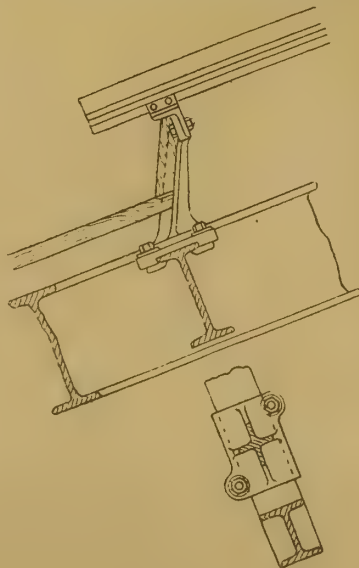

FIG. 243.

the method shown in Fig. 241 can be employed. Thickness webs are riveted between the flanges throughout most of the length, but wide-webbed ribs can be riveted in the positions, and of the length required, or they may be continuous. The

ribs projected as shown serve for the attachment of girders, tie-rods, &c. The same webs may form joint connections between lengths of column.

Examples of castings in roof-work are given in Figs. 242, 243. A light iron standard for a skylight is shown in Fig. 242. These are bolted to both principals and purlins, the latter being that illustrated, by means of hook-bolts. The feet of the castings are made to clip the joint flanges so that they cannot shift. At the top the castings on opposite sides are connected by a light tee-iron, and boards cover over these. The castings down each side are connected by means of an angle-iron A, which receives one end of the sash-bars. The sloping ribs placed one above the other receive the louvres. Fig. 243 is a shorter casting which supports the lower end of the sash-bars, and it is fastened to the purlins similarly to the previous one. J. H.

ACETYLENE GAS: THE NEW ILLUMINANT.

At the meeting of the members of the Northern Architectural Association held at the Art Gallery, Newcastle-on-Tyne, on the 2nd inst., a paper on "Acetylene Gas" was read by Mr. C. T. Marshall, M.S.A., of Newcastle. Mr. F. W. Rich occupied the chair. Throughout the evening the hall was brilliantly lighted by means of the illuminant described. A generator, the patent of Mr. W. H. Dargue, of Grey-street, Newcastle, was connected up to the gaspipes, and thus through the ordinary gaspipes and fittings, but substituting smaller burners. The opinion was generally expressed that the hall had never been so efficiently lighted. Having referred to the interest the introduction of a novel illuminant must possess to all architects, the author proceeded: Acetylene gas, although as a practical light a thing of to-day, possesses a history, and a not uninteresting one. Edmund Davy, in 1836, while experimenting with a process for the production of potassium, found a black residue in the retort, which, like potassium, decomposed water; but instead of the gas given off being pure hydrogen, it was found to be a compound of that gas with carbon, two volumes of hydrogen combining with two volumes of carbon to form a hydro-carbon, differing in composition from any hydro-carbon then known, which we now recognise as acetylene. In 1862 Wohler made carbide of calcium by fusing an alloy of zinc and calcium with carbon, and ascertained that it decomposed in contact with water, forming calcic hydrate and acetylene. In the same year the great French chemist Berthelot made a series of most interesting experiments upon this gas. He found that as the electric arc passed between carbon electrodes in an atmosphere of hydrogen, direct combination took place between these elements, and acetylene was thus synthetically produced. He also found that when the vapours or gases of more complex hydro-carbons came to be passed through heated tubes this same gas made its appearance in small quantities. In addition to carrying out these experiments, he took upon himself the responsibility of giving it a name, and the newest of the hydro-carbons henceforth stood known to the world as acetylene. On October 17, 1892, Macquenne announced to the Academy of Sciences that he had made barium carbide by heating barium carbonate, magnesium powder, and charcoal in an iron bottle, and that on treatment with water or other hydro-xylated compound, it yielded acetylene gas, and on January 19, 1893, Mr. Travers announced to the Chemical Society that he had also made carbide of calcium by heating a mixture of sodium, calcium chloride, and powdered gas carbon, the resulting mixture giving 16 p.c. of calcium carbide. The discovery of a method of making carbide of calcium cheaply and in larger quantities was the result of an accident. Mr. Thomas Leopold Willson, a Canadian chemist, had devised a process for the production of aluminium by the use of an electric furnace, but found himself debarred from carrying out work on aluminium owing to certain patent rights. Whilst attempting to utilise his electric furnace for obtaining the metal calcium by reducing lime with finely-powdered charcoal, he found that at the temperature of the electric arc an interaction took place, which resulted in the evolution of carbon monoxide, and left behind a fused mass which solidified to an extremely hard semi-crystalline body. The experiment was a failure. Anything but pleased with the result of his experiment, Mr. Willson threw the mass into the



stream which drove the turbine. The substance thus thrown so lightly aside made itself both seen and felt in the most unmistakable manner, by causing a violent effervescence in the water, and giving off an odour that demanded the undivided attention of all those who came within reasonable distance of it. This remarkable action was not without its result. Some more of the substance was at once made and examined chemically, when it was found to be what is known as carbide of calcium, and upon being brought into contact with water it gave off large volumes of acetylene gas. In describing Mr. Willson's discovery of the formation of carbide of calcium in the electric furnace, I must not overlook the claims of M. Moissan. Carbide of calcium is a hard, greyish substance, containing 40 parts by weight of calcium, combined with 24 parts by weight of carbon. It has a specific gravity of 2.26, and the theoretical yield of 1 lb. when saturated with water is 5.889 cu. ft. of gas. In practice, the average yield of good commercial carbide is about 5 cu. ft. per pound. The evolution of acetylene gas upon water being brought into contact with carbide of calcium is due to the chemical affinities of hydrogen and carbon and of oxygen and calcium. Immediately upon contact a double reaction takes place. The oxygen of the water combines with the calcium of the calcic carbide to form lime, while the hydrogen of the water combines with the carbon of the calcic carbide to form acetylene. Acetylene is a gaseous compound, composed of 24 parts by weight of carbon with two parts by weight of hydrogen, having a specific gravity, as compared with air, of 0.91. When burnt it gives a flame of intense brilliance, the rays being almost identical with those of the sun. It is far superior as an illuminant to any other known gas, 5 cu. ft. of it giving an illumination of 240 c.p., as compared with 16 c.p. given by the same quantity of coal-gas. It has an intensely penetrating odour, which somewhat resembles garlic, its strong smell being a very great safeguard in its use, as the smallest leakage would be at once detected. Indeed, so pungent is this odour, that it would be practically impossible to go into a room which contained any dangerous quantity of the gas. Although acetylene has, of itself, so recently become a practical illuminant, it has long been recognised as the source of luminosity in all hydro-carbon flames. We have recently had many alarmist statements as to the safety or otherwise of acetylene gas, and I now propose to deal with it from the point of view of its explosibility, poisonous nature, heat of the flame, and products of combustion, as compared with coal-gas. It is explosive over a slightly wider range than coal-gas. Mixtures of air and acetylene commence to be explosive when containing about 5 per cent. of acetylene, while the proportion of coal-gas in a mixture of air and coal-gas required to make an explosion is about 8 per cent. These figures appear to favour coal-gas in the proportion of 8 to 5; but further inquiry more than nullifies this advantage. In an escape caused by a tap being left on, the average coal-gas burner will pass at least 5 cubic feet of gas per hour, during which time an acetylene burner would only pass  $\frac{1}{2}$  ft. of gas, while if the escape were caused by a hole in the pipe, the amount of gas escaping would depend upon the specific gravity of the gas; the specific gravity of coal-gas is .4, that of acetylene is .9, thus the proportionate amount of gas escaping under similar conditions would be two (2) volumes of acetylene to 3 of coal-gas. It will thus be seen that while if the escape is caused by a tap being left on, the comparison is overwhelmingly in favour of acetylene, if it is caused by a hole in the pipe the two are practically equal. This is without taking into consideration the odour of acetylene, which, as previously mentioned, makes no mistake about giving warning of any escape. An acetylene gas flame only gives off one-fifth of the heat given off by a coal-gas flame. For the generation of acetylene gas all that is requisite is to bring carbide of calcium into contact with water. This must obviously be done in one of two methods, either the carbide may be dropped into water, or water may be allowed to flow into the carbide. Both methods have their advantages and disadvantages. Taking the first principle, that of dropping the carbide into water, from a chemical point of view, it is undoubtedly the best; but from a mechanical point of view it has serious limitations. By dropping the carbide of calcium in small pieces into a comparatively large volume of water, there is practically no rise in the tem-

perature, the decomposition is perfect, and having to bubble through the water the gas is condensed, washed, and freed from impurities. Its main disadvantage from a mechanical point of view is the practical impossibility of making at a moderate cost a small automatic generator that will work in a satisfactory manner. The difficulties are of a purely technical nature, and I do not propose to go into them here. Mr. Dargue considers that very large apparatus should be made on this principle, and that they should not be automatic in action. He has designed an apparatus on these lines. The second principle—that of allowing the water to flow to the carbide—is, for obvious reasons, that most generally adopted, the reason being its adaptability to the construction of generators of a moderate size, designed to work automatically by allowing the water to flow by gravity to the vessel containing the carbide of calcium, and the cutting off of the supply of the same, either by the action of a valve closed by the rising of the gasholder when a certain amount of gas having been made causes it to rise above a certain point, or by the back pressure of the gas when a certain amount of gas has been made. As a result of the automatic operation of these generators, a large storage capacity is not required in connection with them; they can, therefore, be made of a comparatively small size, and at a moderate cost. It is, for this reason, practically certain that most generators will be made on this principle, and it is necessary that we should give our very careful attention to any faults that there may be in this principle, and to the methods in which these faults may be overcome. The conditions given rise to by this method of generator which necessitate special precautions being taken to overcome them (and this is especially the case in those machines where the water is sprayed on to the carbide) are that the heat developed during the reaction is sufficient to pulverise some of the acetylene into liquid products of a tar-like nature, and that by decomposing all the impurities present in the carbide, the gas is rendered extremely impure. These impurities, if not dealt with, are likely to find their way into the pipes, and to cause stoppages in the same. The conditions can be overcome by (1) inclosing the carbide container in a water-jacket; (2) by passing the gas through water or some other purifying agent. As I have previously stated, there are two principles on which generators working on this principle can be designed. They may be made on what I call the "gasholder principle," having the supply of water regulated by a valve opened and closed by the falling and rising of the gasholder, or upon what I will call the "back pressure of the gas principle," in which there is no cut-off between the water and the carbide container, the water being driven back by the pressure of the gas after a certain amount has been made. I have here for your inspection this evening an example of a generator made on each of these two principles—they have both been made, as I said before, in Newcastle, by Newcastle firms. The generator on the gasholder principle is one designed and patented by Mr. W. H. Darge, of 72, Grey-street. The generator on the back pressure of the gas principle is one designed and patented by Mr. F. Smith, of Blackett-street.

#### COLUMN TESTS.

IMPORTANT tests conducted under the direction of the Department of Buildings of New York City on cast-iron columns and their details, full size, have been noticed by the American engineering Press. No doubt it was a mistake to confine the compressive tests to one side of the column instead of being measured on opposite sides. The Phoenixville and Watertown machines were used. The tests show rather low resistances per square inch of the sections, the areas of which were from 17.4 to 51.5 sq. in. The largest columns (5 in. and 8 in. in diameter) were only 20 times the outside diameter, so that they were not long examples; the shortest was also extremely short. According to the *Engineering Record*, "five of the shortest columns (15 in. outside diameter) exhibited breaking loads from 29,900 to 32,100 lb. per square inch—i.e., about one-third of the ultimate crushing resistance of cast iron in short blocks. This is a far greater reduction than ought to follow from the small amount of what may be called column influence; it is accounted for by such remarks as 'blowholes' and dirt, 'spots,' 'flaws,' and others applied to the

surfaces of fracture.' Our contemporary refers to the building law of New York, which allows a working load of 11,429 lb. per square inch to be used in 15 in. columns, but the working load is not to exceed one-fifth of ultimate resistance. The least building load of the six 15 in. columns was 24,900 lb. per square inch, and one-fifth of that is 4,980 lb. These tests show, the *Record* says, that there are cast-iron columns in buildings carrying loads equal to half the breaking loads calculated. If the average of the results of the six 15 in. columns be taken, it will be found that the actual safety factor under the loads permitted by the law will be reduced to 2.6 instead of 5. These results are certainly very satisfactory evidences of their strength.

#### THE SURVEYORS' INSTITUTION.

AT the ordinary general meeting of the above society on Monday last a paper was read by Mr. W. Irvine, on the subject of "Land Survey and Valuation in Northern India," a subject which, although it is perhaps beyond the *métier* of an English surveyor, cannot fail to be interesting as showing what has been accomplished by strictly scientific methods to form a system of land taxation, as compared with the system in our own country, controlled, as the latter is, largely by ancient custom. The author dealt only with a portion of India—the Northern Provinces; with which for twenty-five years he was connected. Land valuation of some sort had, he said, always been practised in India, for the revenue of the ruler had always been derived from a share in the produce of the soil. He was formerly considered the sole owner of all rights in the land except the right of actual cultivation and subsistence therefrom. In cases where the Hindu chieftains had never really been subjugated, the share of the Government took the form of annual tribute or fines on succession. The root idea in native administration was that the whole country was the private estate of the sovereign, and that no distinction ought to be made between the rent and the taxation of the land. Whatever could be screwed out of the cultivator was the due of the State.

There were several methods by which the native ruler recovered from the cultivators his share of the crop. There was the actual division of the grain on the threshing-floor, the State taking two-fifths or half. By this method the land did not require to be measured. Or the standing crop could be estimated, and the Government's share commuted into money. This involved a unit of area, and a calculation of the number of such units in the holding. In the case of superior crops, the rent was fixed beforehand. The determination of the ruler to take his dues in money, rather than in grain, necessitated some system of measurement more or less accurate. In 1793 we made the fatal mistake of fixing the land revenue in Bengal in perpetuity without any preliminary accurate survey, with the result that we received now from 13 millions sterling rental value only as much as from less than half-a-million in 1793—indeed, only from 5 to 10 per cent., instead of the 90 per cent. we expected to take in perpetuity. The assessments of the later-acquired provinces were not permanent, but fixed for 20 or 30 years only, and this system had been adopted since 1795, with varying success. After describing the conditions under which the land is cultivated in the area with which he dealt in his paper, Mr. Irvine said the subject divided itself into three parts—(1) The measurements and maps; (2) Statistical records as to assessment; (3) Fixing of rents between landlord and tenant. The work of setting out boundaries fell upon the Revenue officer of the district, the native sub-collector calling upon the head men of a village to point out a boundary line. If there were no dispute this was temporarily marked out and the agreement signed by all concerned. Where disputes occurred it was often very difficult for the deciding officer to settle them to the satisfaction of the parties, although improved maps were gradually lessening this difficulty. After boundaries were marked out they were measured, and later a cadastral survey was made, the separate districts dealt with being about 1,800 to 2,500 square miles in area. The unit of the cadastral survey in Northern India was the "field"; but with the greatest care the boundaries of these fields were often difficult to

determine, especially as a field held by one tenant and sown with one crop often belonged to different owners. An instance was given where a field of a quarter of an acre belonged to ten owners. When the lands were first assessed, 90 per cent. of the rental was taken as the tax, leaving 10 per cent. for management, and also allowing the owner the profit on the land he held rent free. But this was found to be excessive, and it had been gradually reduced to 50 per cent. plus another 10 for various expenses. The system at present in force, which was to some extent a survival of the old custom, amounted practically to allowing the settlement officer first to fix the amount of the assessment, and then by it to rule what the rent must be. This, experience had taught the author, worked well and equitably. Many more detailed statistics were given in the paper, for which we have not space, but which were listened to by the members with great interest, and which will no doubt form a valuable addition to the *Transactions* of the Institution. A vote of thanks was moved by Mr. Daniel Watney, and seconded by Mr. J. H. Sabin, and, after short speeches by Sir Edward Jenkinson, Mr. Howard Martin, and Mr. Newmarch, was put to the meeting, and carried unanimously.

#### ARCHITECTS' BENEVOLENT SOCIETY.

**T**HE annual general meeting of the Architects' Benevolent Society was held in the rooms of the Royal Institute of British Architects on Wednesday, the 9th inst., Mr. George Scamell taking the chair in the absence of the president, Professor Aitchison, R.A. There was a good attendance of members, Colonel Robert W. Edis, F.S.A., Mr. Henry C. Florence, Mr. T. M. Rickman, Mr. Sydney Smirke, Mr. J. T. Christopher, Mr. H. H. Collins, Mr. Henry T. Hall, Mr. Wm. Woodward, Mr. W. Hilton Nash (honorary treasurer), and Mr. Percivall Currey (honorary secretary) being amongst those present. Letters regretting inability to attend were read from Mr. Arthur Cates, Mr. Zephaniah King, and Mr. G. T. Hine.

The honorary secretary read the annual report of the council:—The amount received in annual subscriptions during the year was £456 10s., as against £453 8s. in 1896. Four members have withdrawn, and twelve members were in arrear with their subscriptions when the books were closed for the year.

At the beginning of the year there was a balance of £64 10s. 2d. to the credit of the Capital Account, and the amount of bequests and donations received during the year came to £300 17s. 7d. It was, therefore, decided to increase the society's investments by the purchase of £200 Caledonian Railway Four per Cent. Debenture Stock, and the purchase was effected at a cost of £311, thus leaving a balance to the credit of this account of £54 7s. 9d.

A larger number of applications for assistance than usual were made to the society, and considered by the council. After proper investigation in each case the sum of £607 1s. (as against £569 10s. in 1896) was distributed amongst forty-three applicants; and £70 was paid to the Society's three pensioners.

As the exertions of successive councils for many years have succeeded in bringing the amount of the invested capital up to £10,000, the council consider that the society might now increase its present list of three pensions of not less than £15 a year each, to six pensions of not less than £20 a year each. The approval of this step would, the council think, add to the happiness of deserving applicants by the knowledge that they were to receive annually a certain sum. A motion to alter by-law No. 65, so that the above proposal may be carried into effect, was therefore submitted and carried.

The chairman moved the adoption of the report, and the motion was unanimously carried.

Mr. Henry T. Hall proposed, and Mr. Christopher seconded, a vote of thanks to the outgoing members of council.

Colonel Robert W. Edis moved, and Mr. H. H. Collins seconded, the election of the council for the ensuing year of office as follows:—President, the President of the Royal Institute of British Architects; Mr. Arthur Crow, Mr. E. A. Gruning, Mr. G. T. Hine, Mr. Arthur Cates, Mr. Aston Webb, Mr. H. L. Florence, Mr. J. T. Christopher, Mr. Sydney Smirke, Mr. W. Grelhier, Mr. E. W. Mountford, Mr. R. St. A. Rou-

mieu, Mr. Wm. Woodward, Mr. E. B. P'Anson, and Mr. E. H. Martineau.

Mr. Forster Hayward and Mr. George Lethbridge were elected auditors for the ensuing year of office.

#### ORNAMENTAL BRICKS AND TILES.

**T**HE Hartshill Brick and Tile Co. (J. and T. Birks), Stoke-upon-Trent, Staffordshire, have published an illustrated price list, which will enable those who deal with this well-known firm to select their patterns of goods with the gross prices appended. The architect finds it also an advantage in being able to select his patterns of ridge or finial, roofing tile or paving tile, when he specifies this portion of his work. The bricks, tiles, and other goods manufactured by Messrs. J. and T. Birks have excellent qualities: they are sound, well shaped, and of good colour, as all can testify. The ridge tiles made in red, blue, brindled, or Broseley colours, plain and capped, are of various patterns and prices. T-junctions, with grooved ridges for ornamental crests, quoin tiles for hips, &c., are illustrated. The 12in. "fast ridges" are of many kinds, and the finials display a large assortment for gables and hips. Some of these are suitable for church gables. The roofing-tiles (red, Broseley or brindled) are of several kinds, and of excellent quality; plain tiles 10½ by 6½, 60s. per 1,000, ordinary hand-made; others are pressed. Several sections of blue vitrified wall-coping and stable-channels are shown. Red, blue, and buff paving-tiles, encaustic pavements, terracotta panels, and sanitary ware are other goods shown in this useful list. We notice some very moderately-priced glazed hearth-tiles. These vary in price from 18s. 6d. to 22s. per hearth, and the glazed wall-tiles vary from 16s. to 20s. per yard super. The sanitary goods comprise a few excellent patterns for siphons, with inlets and intercepting traps; and some good cottage hopper closets and traps, closet basins, stoneware sinks, lavatory, and other fittings. The "Builders' Notes" prefixed to the catalogue are useful, and we recommend our readers to send for a copy. One advantage is that gross prices are affixed instead of net prices, from which a trade discount is given.

#### USEFUL ITEMS FOR BUILDERS, PLASTERERS, PAINTERS, PAPER-HANGERS, &c.

1. **A** GLUE or putty for cementing water-tanks that are not zinc-lined is composed as follows:—Melt 9oz. guttapercha, and when melted stir in 25oz. pumice-stone powder, and then add 50oz. of Burgundy pitch. Lay this compound (hot) on the inside of the tank, and pass a heated iron over its surface to smooth it. The tank may be filled with acids instead of water, but the wood of it will not be affected by same.

2. Another compound for a similar purpose is prepared by melting together equal parts (by weight) of pitch, rosin, and dried plaster of Paris.

3. A colourless cement for plastering up cracks in structures exposed to the fumes of acids is prepared by mixing silicate of soda with powdered glass to form a stiff paste, and using this paste as a cement.

4. An acid-proof cement is also prepared by mixing either china-clay with boiled linseed-oil, or quicklime with raw linseed-oil, or pipe-clay and coal-tar may be used.

5. To resist boiling acids, prepare a compound of indiarubber, tallow, dry slaked lime, and red lead, as follows:—Melt a sufficient quantity of indiarubber over a sand-bath, and then add 6 to 8 per cent. of its weight of tallow, and well mix in this ingredient by stirring the whole; then add sufficient dry slaked lime in powder to bring the mass to the consistency of soft paste. Finally, mix in 20 per cent. of red lead to make the compound harden and dry.

6. Another waterproofing cement and plaster is prepared by melting separately 50 parts of sulphur, 1 part of tallow, and 1 part of rosin, and mixing the three ingredients while hot, and then adding sufficient ground glass to make a stiff compound.

7. Cement and plaster to resist fumes of nitric and hydrochloric acid is prepared by melting and mixing equal parts of rosin and sulphur, and then stirring in brickdust equal to carry the weight of the compound, or all three components may be mixed in the dry state, and the compound then heated and stirred.

8. A plaster cement that will soften without melting so to adapt itself to the expansion and contraction of metal is prepared by dissolving 1 part of pure rubber in 2 parts of linseed oil, and then stirring in 6 parts of pipeclay.

9. A similar cement for an identical purpose is obtained by melting 24 parts of rosin, and, while this is hot, stirring in 4 parts of dry red ochre, 2 parts of calcined plaster of Paris, and 3 parts of linseed oil.

10. An acid-proof plaster is composed by melting 1 part of guttapercha in sufficient boiled oil, and then stirring in 4 parts of rosin which has been previously melted. Apply this mixture hot to the dry wood or metal, and then go over the surface with a hot iron on purpose to drive the cement into all cracks and crevices.

11. A cement or plaster for oil tanks is prepared by making into a paste with a little water (oil can be made to mix with water by means of lime) 5 parts of litharge (ground fine) 2 parts of unslaked lime, 2 parts of quartz sand.

12. An insoluble plaster or cement for paraffin-oil tanks: Take 4 parts of strong soda lye and dissolve therein 3 parts of powdered rosin. Stir the compound until all ingredients are well incorporated. Allow it to become cold, and then dilute with 5 parts of water, and when all is properly diluted work in 5 parts of plaster of Paris.

13. A solder for metal tanks that are to hold petroleum, kerosene, paraffin, &c.: Melt together 6 parts of lead, 4 parts of tin, 5 parts of bismuth.

14. A waterproof glue for woodwork: Soak 5 parts of glue in water for 12 hours; then pour off any unabsorbed water and dissolve the glue by heating it. Stir in 4 parts of powdered rosin, and when that has melted in the hot glue stir in 3 parts of red ochre.

15. A waterproof cement or putty for metal or wood is prepared by mixing 10 parts (fluid measure) of bisulphide of carbon and 1 part (fluid measure) of oil of turpentine, and then add as much guttapercha as will dissolve in the fluid to a thick paste. The compound so formed is flexible and waterproof, and dries hard as soon as the excess of bisulphide evaporates.

16. A hydraulic plaster or cement is prepared by pulverising 45 parts of limestone, 2 parts of grey clay, 3 parts of black oxide of manganese (all parts by dry measure). After mixing the mass by sieving several times, calcine them at a dull red heat, and reduce to powder; for use, mix with water and a little sand like ordinary mortar. The limestone may be sprinkled with water and allowed to become reduced to dry powder before mixing with the other compounds.

17. Another hydraulic cement is prepared by mixing in the state of powder 25 parts of lime and 3 parts of manganese iron ore, calcine the mixture and then reduce it to powder again. For use, mix with a little sand, and then make into a mortar with water.

18. A waterproof cement for marble and stone is prepared by slaking lime by sprinkling it with water, and while this is slaking curdle some milk by adding a little vinegar to it, strain off the curds from the whey through a cloth, and mix this fresh curd with the slaked lime as it is required for use. This cements sets very quickly.

19. An artificial cement is prepared by reducing to powder and then well mixing by sifting through a fine wire sieve, 6 parts of freshly-ground plaster of Paris, 3 parts of brickdust, and 4 parts of refinery cinders. For use, mix this compound with water, and shortly before the cement is to be used mix thoroughly with 2 parts of sifted iron filings; use like ordinary mortar, but as thin and soft as possible.

20. To render brick masonry waterproof, repeatedly wash the wall with the following solution:—(a) 12oz. Castile soap, 1gal. of water; (b) 2oz. of alum, 1gal. of water. Brush the wall first with (a) solution. The wall should be clean and dry, and the temperature of the air not below 50° Fahr.; laid on boiling hot. Give it 24 hours to dry before applying (b) solution, which should be applied when the temperature of the air is 60° to 70° Fahr. After 24 hours repeat the soap and the alum solution, and repeat both solutions alternately at intervals of 24 hours, until the wall is sufficiently impervious to water.

21. A cement for repairing granite is made by reducing to an impalpable powder equal parts of black feldspar and marble dust, and mixing in powdered gum dammar. Heat the mixture until the gum melts, mix the whole by stirring, and then apply to the fractured parts of the granite like putty is used.

22. A cheap cement for many purposes is a mixture of quicklime (unslaked lime) and hot glue.

23. A cement or plaster for paving, such as Lyons asphalt, is prepared by heating to boiling-point 3 parts of bitumen, and then mix in 7 parts of coal cinders. Let the mixture continue to boil until the froth ceases to rise; this should be skimmed off separately. Mix together 2 parts of powdered coke and 26 parts of lime; heat this compound to 575° Fahr., and then mix it with that in the boiler, and finally stir in 32 parts of fine grav 1. Continue the heating and stirring until well mixed, and then lay on the pathway, which should have been previously levelled and covered with a layer of foundry cinders or other suitable material. All irregularities should be removed by smoothing the asphaltum while it is hot.

24. Cements and putties for masons' use: Dissolve alum in water until the fluid will not dissolve any more, then mix in this sufficient plaster of Paris to make a stiff dough and bake it; when baked hard and dry grind it to powder, and for use mix with water as wanted, and apply it like plaster. Various pigments may be mixed with it (while in the dry state, after baking and grinding) to make the cement imitate the colour of any kind of marble it is required to cement or join. Joints made with this compound can be polished as smooth as glass, and thus the joint in the marble-work may be rendered imperceptible.

25. A cement or mortar for marble: melt together 8 parts of rosin and 1 part of white wax, and while hot stir in 4 to 5 parts of dry plaster of Paris, and use the compound while hot. The surfaces to be joined should also be heated before cementing with the putty.

26. A slow-setting cement which requires only a thin layer to be used in joining marble is prepared by mixing together, in the dry state, 12 parts of Portland cement, 6 parts of slaked grey lime, 6 parts of sand, and 1 part of kieselguhr (fossil meal or infusorial earth); when these ingredients are all well mixed by sifting, make the compound into a stiff paste with silicate of soda as required for use.

27. Plaster cornices and marble skirtings may be imitated by either of the following compounds:—(a) Take moderate sized lumps of native gypsum (sulphate of calcium), and burn them at a temperature below red heat, and at the same time prepare a solution of 1 part of alum in 10 parts of water—using hot water and powdered alum. In this solution steep the warm lumps of gypsum for about fifteen minutes; take them out and allow to drain off all surplus fluid, and then again burn the lumps at a red heat. Afterwards reduce to powder, and when wanted for use mix with water like ordinary plaster of Paris. It will not set so quickly as the ordinary plaster, but be a slow-setting cement, and while pliable, can be moulded in the usual way. When perfectly dry it will become very hard. Dissolve chloride of zinc in water to make a solution having a specific gravity of 1.490 or 1.453, and then put into such solution 3 per cent. of borax or sal ammoniac (chloride of ammonia). Meanwhile, heat oxide of zinc until it is red hot, and allow it to cool, and when the borax or ammonia salt is dissolved, put in sufficient zinc oxide to produce a compound of the desired consistency; mould the compound while plastic, for when cold it will be as hard as marble, and take a fine polish.

28. A cement to imitate any kind of marble or stone is prepared by taking some of the dust of the marble or stone it is desired to join, and then mixing powdered shellac therewith, and use this as a putty or cement by melting the compound at a suitable heat, and kneading it to a kind of putty.

29. A cement for joining rockwork for grottoes, when it is desired that the plaster or cement should not be seen, is at once to hand by using the commonest sealing or parcel-wax, or same can be prepared by melting first 8 parts of common rosin, allowing them to cool sufficiently to permit of 2 parts of oil of turpentine being added without catching fire. Stir up well, and re-heat; and then add 2 lb. of good quality rosin (yellow rosin or colophony). When that has melted, stir in and well mix 3 parts of powdered chalk, perfectly dry, and then 3 parts of dry brickdust.

30. Modern Roman cement consists of a mixture of ordinary clay, calcined, and lime, the compound, after mixing, being recalcined. The proportions are 3 of clay to 2 of lime. The original Roman cement consisted of pulvis Puteolanus, or pozzuolana (a ferruginous clay from

Puteoli), calcined by the fires of Vesuvius, lime, and sand, mixed with soft water. The pozzuolana only needs to be reduced to powder and sifted. To give the compound greater tenacity, fresh bullock's blood is mixed with it occasionally.

31. Sawdust instead of hair in mortar is a good substitute. The sawdust should be well dried and sifted before use, and then the mortar made by mixing 1 part of cement, 2 parts of lime, 2 parts of sawdust, and 5 parts of sharp sand. The sawdust should be first well mixed dry with the cement and sand; then strew the lime over this, and sprinkle the mass with water, and work up into mortar.

32. A cheap cement is prepared by mixing blast-furnace slag with lime and clay, in the proportion of 2 slag, 5 lime, and 2 clay; calcine the whole, and reduce to powder.

33. Slate may be cemented by compounding boiled linseed-oil, white-lead, and chalk. Make the compound into a fluid condition.

34. To fix iron bars in stone: Melt sulphur, and work in the melted mass plumbago or graphite. This renders the sulphur more elastic. A little boiled oil may also be added, as also sand or rosin instead of the plumbago. Sulphur alone is very brittle.

35. Cement for terracotta: Melt 5 parts of rosin, then add 5 parts yellow wax, and finally add 1 part of sulphur. Lastly mix in half part of furnace slag and quartz sand. Warm the terracotta, and then apply the cement and finish off the joint with powdered terracotta.

36. Turkish mortar: Pound up bricks and tiles, and mix 1 part of this with 2 parts of fine sifted lime, and make into mortar with water to the desired stiffness, and lay on 5 in. or 6 in. thick between the courses of bricks and stone.

37. Pitch plaster for waterproofing walls: Put 50 parts of pitch into a cauldron and melt it; then add 30 parts of common resin, and when melted mix in 6 parts of red ochre and 12 parts of brickdust, finely powdered. Boil up, and well mix by stirring, and then allow to cool, and then bring the compound to a fluid consistence (so as to spread speedily) by adding about a quarter its bulk of oil of turpentine. Lay the plaster on the wall with a brush or tar-mop.

38. A useful cement for general use is prepared by mixing to a paste with water 1 part powdered slaked lime, 1 part sand, and 6 parts iron filings.

39. White hydraulic cement. Mix 1 part of infusorial earth (kieselguhr) and three parts of chalk free from iron rust, 1 part of a solution of potash or soda water-glass, and make the compound into a dough, and then into bricks, which burn at a white heat, and then reduce these bricks to a fine powder, and mix with water to form a cement when required for use.

40. An insulating cement for electrical fittings is prepared by soaking for 12 hours 1 lb. best cabinetmaker's (or white) glue in 2 quarts of water, and when properly softened melt the glue in a glue-pot by heating it with the whole of the water, and then cut up 1 oz. of white curd soap (this is a hard tallow soap, made from tallow and soda salts), and when this has been dissolved stir in 52 oz. of plaster of Paris, and mix the whole by stirring so as to form a thin paste, which should be used at once, as it rapidly sets and hardens. For insulating electric-light wires and other electrical fittings fixed in walls, this is a most useful element.

41. An insulating cement for glass electrical fittings is prepared by mixing equal weights of red and white lead ground up in oil.

42. Another useful cement for the same purpose is to melt together 5 parts of rosin, 1 of beeswax, and 1 of dry Venetian red.

43. Another cement of a similar kind is prepared by heating together at temperature above boiling water (212° F.), 14 parts of black rosin, 2 parts of red ochre, 1 part of plaster of Paris, all well dried and mixed while warm. Continue the heating until all frothing ceases and the compound flows smooth; then remove the vessel from the fire, and stir its contents until sufficiently cool for use. Half-part of linseed-oil may be added at will.

44. A cement for oil of vitriol and chloride of lime tanks is prepared by mixing thoroughly together equal parts of pitch, rosin, and plaster of Paris.

45. A cement for fastening fittings that are used in apparatus for alkaline fluids is prepared by melting four parts of yellow wax and dissolving this two parts of Venice turpentine, and

then stirring in one part of red oxide of iron (well dried beforehand).

46. To repair broken glass electrical apparatus, mix together by sifting two parts of flour, two parts of finely-powdered glass, two parts of finely-powdered chalk, and one part of powdered brickdust, one part of shredded lint, and then make into a putty with one part of white of egg. Spread this on linen, and lay it on as a plaster over the crack in the glass.

47. A fireproof cement for fireclay-lined furnaces is prepared by mixing freshly-slaked lime into a paste with a concentrated solution of borax, and allowing this cement to become thoroughly dry before using in furnace.

48. A cement for a similar purpose is prepared by mixing into a paste with a saturated solution of borax in water equal parts (or otherwise) of dried clay powdered and powdered brickdust.

49. For furnaces that are required to stand a fierce heat, use either the last-named compound or else a paste made with 2 parts of borax, 2 parts of slaked lime, and 1 part of litharge and water.

50. A cement to withstand a dull-red heat is prepared by mixing plaster of Paris with a weak glue.

51. A cement or plaster resistant to corrosive gases is obtained by drying clay, powdering same, and sifting it, and then gradually working into a paste by rubbing it up in an iron mortar with boiled or drying-oil, the latter being added a little at a time. This cement will not resist heat, but softens thereby.

52. A cement for repairing gas-bags used in limelight and similar purposes, is prepared by adding glycerine to very thick boiled glue, and applying same while warm. If too sticky, strew over it powdered soapstone. This cement is useful for repairing leakages; but for tears or rents put a piece of the material over the rent, and well cover it with glue.

53. A fireproof glue is readily prepared by mixing a handful of quicklime in 4 of linseed oil, and boil to a stiff consistency; then spread the compound on metal or earthenware plate, and dry it in this state by exposure to the air. When wanted for use, dissolve it over the fire as ordinary glue.

54. A universal cement is prepared by dissolving 1 part of rosin, 1 part of Stockholm tar, and 2 parts of guttapercha by heating together.

55. To insulate electrical conductors, use a cement or plaster prepared as follows: Dissolve 26 parts by weight of paraffin-wax (or else beeswax, or spermaceti ditto); when melted, add 3 parts by weight of raw or boiled linseed-oil, and then stir in 66 parts by weight of finely-powdered glass or quartz, and 34 parts by weight of powdered rosin. If this insulating material is to be exposed to the sun, use less wax; and if for underground use, employ a larger proportion of wax.

56. A flexible insulating cement for electrical apparatus or plant is prepared by melting 1 part by weight of mineral wax (paraffin oxycerite), 10 parts of wood-tar, 32 parts of shellac, and 32 parts of dry and finely-powdered asbestos (or else flax, cotton wool, sawdust, or paper. Heat the compound from 100° to 200° F., while constantly stirring. Use less tar for a leading wire, and for a very hard wire omit the mineral wax, use less asbestos (or the other bodies mentioned), and add 24 parts of powdered slate or clay free from iron.

57. An insulator for tape-covered electrical wires is prepared by mixing 1 part of raw linseed-oil with 20 parts of oil of turpentine, and dissolve in this fluid sufficient pure gum-rubber (guttapercha) to form a mixture of the consistency of paint.

58. An insulating cement for a similar purpose is also prepared by melting together by heat 8 parts of yellow wax, 2 parts of beeswax, and 1 part of tallow.

59. Electrical insulators may be cemented to their attachment by mixing sulphur, dry white lead, and plaster of Paris in sufficient glue (solution being made in the ordinary way) to prevent the compound setting quickly.

60. A lute or cement for stopping cracks in iron retorts is prepared by mixing 2 parts of flour, 2 parts of lime (quicklime), and 1 part of potter's earth into a paste, with white of egg diluted with an equal bulk of water.

61. Another lute for the same purpose is prepared by mixing together, in the dry state, equal parts of brickdust and red-lead, and then rubbing

up the mixture to a putty with boiled linseed oil, and add coarse sand to stiffen the mass.

62. A fusible fireproof lute for the same purpose is prepared by rubbing up freshly-slaked lime into a concentrated solution of borax. Apply this mixture with a stiff brush, allow it to dry, and when it is heated, the mass fuses into a glaze or glass.

63. Another cement or plaster for a similar purpose is made by mixing 3 parts litharge, 2 parts freshly-burnt pulverised lime, and 1 part of white bole with linseed oil to a putty or paste.

64. Cement for fastening brass to glass: Boil 3 parts of rosin in 1 part of caustic soda and 5 parts of water, and mix the resulting resinates (a kind of soap) with half its weight of plaster of Paris.

65. Cement for fastening iron on glass: Soak white glue or gelatine for twelve hours in water, and then pour off the superfluous water, and mix in with the glue one-fourth part by bulk of treacle. Heat this gently until well incorporated. A little glycerine may be added to keep the compound from being too tenacious. Every time this compound is heated (it softens by heat) it contracts, until at last it will no longer melt by heat.

(To be concluded.)

### SCHOOLS IN THE STATES.

THE subject of ventilation of public schools is receiving attention in Baltimore. The health commissioner, Mr. Shane, reports to the City Council on the question, and urges them to promote legislation providing for the proper lighting, heating, and ventilation of schools. He recommends that not less than 15sq.ft. of floor space, and 2,000c.ft. of air per hour per pupil should be provided. The air should be delivered into the room near the ceiling, allowing it to diffuse at the top of room and then settle down. This air should be warmed sufficiently. The light should enter the room from the left of the pupil, and should never be less than one-seventh of the floor area. The hall space should be one sixth of the room space. The entrances should be ventilated, and all stairways made fire-proof. It is also recommended that foot warmers should be placed in each hall so that the children may dry their feet in wet weather. The air of cloak-room should be heated and changed at least four times an hour. It is certainly quite time legislation should make it compulsory to provide air-space and proper ventilation in the schools of the States. In this respect our English schools are much in advance of those in the United States, where science has been spent in the erection of "tall buildings" and other mechanical feats, while hygiene has been neglected.

At a meeting held at Wakefield of the Walsham How Memorial Committee, it was reported that the amount promised towards the enlargement of the Cathedral was £3,840 3s., and towards the recumbent effigy £380 6s., a total of £4,220 9s. Mr. Frank L. Pearson is the architect to the committee.

The foundation-stone of the new Church of Our Lady of Perpetual Succour has been laid at Gillingham, near Beccles. The church, as designed by Mr. F. E. Banham, architect, will be built in the Roman style by Messrs. Allen, contractors, Beccles, and will consist of sanctuary, nave, and campanile, with sacristy, confessional, and lobby on the south side. Its dimensions are 77ft. by 22ft.; and will present a structure of red brick with stone dressings, and campanile of brick with stone cupola 60ft. high. In the interior there will be a circular apse and circular ceiling, and the walls will be divided into bays with pedestal columns and cornices of the Doric order.

Mr. Justice North, in the Chancery Division, on Saturday, heard a petition presented on behalf of the National Dwellings Society, Ltd., asking the sanction of the Court to the reduction of its capital, owing to the defalcations of its former managing director, A. T. Hawkins. The company was for some time under the control of Hawkins, who committed numerous frauds upon the company, misappropriated money, and wrote up fictitious values of the company's property. A committee of investigation was appointed, which discovered the frauds, and he was prosecuted. He was sentenced to five years' penal servitude. The present capital of the company was £150,000, divided into 30,000 shares of £5 each. It was proposed to write off £93,183 10s. as capital lost or unrepresented by available assets, thus reducing the capital of the company to £56,816 10s. His Lordship sanctioned the reduction.

### OBITUARY.

MR. JAMES EDMESTON, F.R.I.B.A., F.S.I., of 42, Old Broad-street, E.C., one of the oldest architects practising in the City, died on Friday last at his residence, 49, Inverness-terrace, Hyde Park. Mr. Edmeston, who was in his 75th year, succumbed to an attack of bronchitis. The son of Mr. James Edmeston, the author of many Evangelical hymns still well-known and often sung, Mr. Edmeston was the pupil and managing clerk to the late Arthur Asphitel, but had spent the whole of a long professional career in the City, where he built up an extensive practice in designing banks, offices, warehouses, and other premises for commercial purposes. His wide experience, sound judgment, and business capacity made his services in later years widely in request in arbitrations, and also as assessor in architectural competitions. He was the official arbitrator to the City of London Court, and one of those appointed under the Board of Trade, while among recent competitions in which he acted as assessor may be named three at Richmond, Surrey—those for the municipal buildings, the isolation hospital and coroner's court, and one decided only a fortnight since, that for the workhouse infirmary at Dorking. He was for some years in partnership with his only son, Mr. James Stanning Edmeston, and upon that gentleman's death in September, 1884, he took into partnership Mr. Edward Gabriel, of Old Broad-street, E.C., and Bristol, by whom the practice will be continued. Among the later works carried out by Messrs. Edmeston and Gabriel may be named the completion of Olympia on the deaths successively of Mr. Peck and Mr. Coe; a large number of suburban banking premises for the London and South-Western Bank, and also their head-office, the most recently opened being that at Kilburn; the free library at Tottenham; the free library and fire-brigade station and isolation hospital at Willesden; extensive works for the Brush Electric Company at Loughborough, Leicestershire, now approaching completion; and many buildings at Bristol and its vicinity. Mr. Edmeston took a keen interest in the introduction of zinc as a practicable building material, and many years since read papers before the Institute on the methods of selecting, laying, and preserving the metal. He was one of the promoters, and until his death a director, of the Architectural Union Co., the owners of No. 9, Conduit-street, so long the home of the Royal Institute of British Architects and the Architectural Association, and was for many years its chairman, an office in which he was succeeded a year or two since by his old friend Mr. Arthur Cates. He joined the R.I.B.A. as an Associate in 1856, becoming a Fellow three years later, and subsequently served on the council, and was one of the oldest members, his place on the roll of membership this year being No. 36. He was one of the founders of the Architectural Association, and occupied the presidential chair so far back as 1853-4, having been a vice-president the previous year. He was also a Fellow of the Surveyors' Institution, and a member of the Surveyors' Association. He had been a member of the Bread-street Ward in the Common Council of the City since 1863, and was elected Deputy of that Ward in 1880. He took a hearty interest in the craft of Freemasonry, and was Past Grand Superintendent of Works, and, therefore, a member of Grand Lodge; also a member of Grand Chapter. He was for a long period the chairman of the Society for the Promotion of the Fine Arts, and on his resignation of that office some time since, owing to advancing years, was elected a vice-president. He was twice married, and leaves, by his first wife, three daughters; his second wife survives him. The funeral took place yesterday (Thursday) at noon at Brompton Cemetery, and was attended by the family, Mr. Gabriel and the members of the staff, and by representatives of the Royal Institute of British Architects and of the Corporation.

On Friday evening, Mr. G. P. Wyatt, coroner, opened an inquest at the Lambeth Coroner's Court on the body of SAMUEL JOHN LONG, aged 60 years, an architect, lately residing at 14, Mostyn-road, Brixton, whose death occurred under mysterious circumstances. Deceased left home at 10 a.m. on the previous Wednesday to collect some rents, and half an hour later a green-grocer passing the house heard a loud crash, and deceased was found in the footpath opposite his own door, obviously suffering from severe injuries. Death ensued within ten minutes. Medical evi-

dence showed that the spinal column, sternum, one thigh, and all the ribs except two were broken, and there was also a compound fracture of one ankle. The doctor stated that the extent of damage could not have been greater had deceased fallen from the top of a spire or been run over by a traction engine. Nothing transpired as to how deceased met with his injuries, and it was thought impossible he could have returned unperceived to the house to have thrown himself from the roof, a flat one, or a window. The inquest was adjourned.

### CHIPS.

A new clock, in commemoration of Her Majesty's Diamond Jubilee, has just been fixed in the tower of Glentworth Church. The order was given to Messrs. W. Potts and Sons, of Leeds.

Several hundreds of the sufferers in the recent typhoid epidemic at Maidstone have decided at a private meeting to bring a combined action against the water company to obtain compensation for the losses which they have sustained. The company had expressed their willingness to make a grant of £3,000 as compensation, on conditions which the consumers could not accept.

At a vestry meeting held at Padstow, Cornwall, last week, plans were unanimously agreed to for reseating the fine old parish church, and a restoration committee was appointed. According to the *Royal Cornwall Gazette*, the plans were "prepared by Mr. Samuel Martyn, of Gragmeer, Mr. Pridaux-Brune's head gardener of the manor."

Damage to the extent of over £100 was caused by a fire which broke out on Friday night on the premises of S. and R. Horton, joiners, in Portland-street, Lincoln.

The Manchester Corporation granted at their last meeting the following advances of salary in the waterworks department:—Mr. William Blackstock, secretary, £400 to £450; Mr. Joseph Haynes, general inspector and surveyor of mains, £350 to £400; and Mr. L. Holme Lewis, engineer and manager of the hydraulic power supply, £350 to £400.

A light railway has now been authorised to be made from Helston to The Lizard. It will be 11½ miles long, and there will be three fixed stations: at Dodson's Gap, two miles from Helston; at Trevassack, five miles from Helston; at Penhale, about 3½ miles from The Lizard, and near The Lizard Village, where the line will terminate.

It has been determined that from the 31st inst. the administration of the grants for drawing and manual instruction in public elementary day schools shall be transferred from the Department of Science and Art to the Education Department.

A syndicate of Airdrie gentlemen have secured from the Caledonian Railway Company a site of 12 acres between Calder and Whifflet stations whereon to erect extensive ironworks for the production of merchant bars, &c. Operations have been begun, and arrangements are being made so that the ironworks can be considerably extended, and a steel plant can be put down. Mr. David Home Morton, A.M.I.C.E., has been commissioned to design and put down the necessary works.

At the last meeting of the Liverpool Corporation, Mr. John Alexander Brodie, Whitworth Scholar, M.Inst.C.E., M.Inst.M.E., was appointed city engineer and surveyor to the urban sanitary authority in place of Mr. H. P. Boulois, resigned, at a salary of £1,000 per annum, under the usual conditions. It was stated that there were 52 applicants for the position, ten of whom appeared before the committee, and the choice of Mr. Brodie was unanimous.

A new home for nurses engaged at the Bradford Workhouse and additional cottage homes for boarded-out children in the same institution were opened on Saturday. The home for nurses has cost £7,000, and that for children £1,500. The plans are the joint production of Mr. J. H. Martin, of Newcastle, and Mr. J. P. Kay, of Leeds, and the nurses' home is built on the pavilion plan, and has accommodation for 36 in the bedrooms.

The foundation-stone of church Sunday-schools for St.7thians was laid on Monday week. The new building, which is close to the church, will contain main room, 48ft. by 24ft., and a classroom adjoining, 17ft. by 9ft. Local stone will be used, with granite dressings. The architect is Mr. W. Swift, of Truro, and the builders are Messrs. John Symons and Son, of Blackwater. The cost will be £550.

Good progress is being made with the extension of the steamboat pier at Walton-on-the-Naze. The extension reached its full length in an easterly direction on Friday—viz., 2,000ft. Now the works will proceed in a southerly direction for 600ft.

With a view to improving the water supply at Wallasey, the water committee of the council have decided to carry out boring operations at the Liscard works, at an estimated cost of £1,500.

### PROFESSIONAL AND TRADE SOCIETIES.

**AMALGAMATED SOCIETY OF HOUSE-DECORATORS AND PAINTERS.**—On Saturday, this society brought to a close their Bristol conference. Every weekday for a fortnight the general council of the organisation, numbering between forty and fifty delegates, met for the discussion of rules which form the constitution of the society. One of the most important proposals which received attention in the latter part of the conference was that to establish an out-of-work benefit fund. The Worcester District had on the agenda a detailed set of proposals for a fixed scale of pay, and these were based on the assumption that 4d. per week extra contribution would enable 10s. per week to be paid to men not in work. The council, however, although not in the possession of figures sufficient to enable a scheme to be formulated, seemed convinced that such a rate of benefit could only be given by increasing this contribution to 6d. or 7d. at least. Several delegates opposed the idea of making such a scheme compulsory; but the council, by a majority of only one vote, affirmed the principle of such a scheme, and appointed a special committee to go into the whole question, and submit the result of their deliberations to the branches. Another matter of interest was a motion in favour of a superannuation fund. The allowance suggested was 5s. a week to a member 60 years of age who had been in the society for 15 years, and 7s. per week for a member of 20 years' standing. This, however, it was proposed to accompany with conditions calculated to reduce materially the liability such superannuation involved upon the society. The member superannuated was to lose all benefits other than funeral benefit, and it was pointed out that among members over sixty years of age sick pay was at present a serious item. Beyond this, members would not be superannuated if earning more than half the usual rate of wages, so that a painter retaining his health and strength had little temptation to throw himself on the superannuation fund. The superannuation scheme received a good deal of support, but not enough to carry it. A scheme was adopted which calls into being district management committees, to deal with wages, hours of labour, overtime, and the general conditions affecting the interests of the trade in the respective districts, and to bring about the amicable settlement of disputes with employers where possible. A resolution in favour of separating the trade and sick benefit funds was defeated. It was decided that in future the strike pay will be 2s. 6d. per day, instead of 1s. 8d. as heretofore. Messrs. Gaiger, Bennett, Dunkin, Matthews, and Owen were appointed a committee to draft a scheme of out-of-work benefit, and Messrs. Dunkin and Bennett were appointed to act with the general secretary in the tabulation of the rules. Birmingham, London, Cardiff, and Leicester were nominated for the next general council meeting, and Birmingham was selected.

**BIRMINGHAM ARCHITECTURAL ASSOCIATION.**—A meeting of the members of this association was held on Friday night at Queen's College, Paradise-street, when an address was delivered by Professor Aitchison, R.A., P.R.I.B.A. The President (Mr. C. E. Bateman) presided, and there was a good attendance. Professor Aitchison said the first thing anyone who desired to become an architect should be sure of was that he had a natural gift for the work, and if he found that he had no taste for it, and that he had been mistaken in the passion, he should get his living in something else. The profession of an architect was by no means a money-making profession, and if a person found he could not devote himself with all the energy he possessed to the study of architecture he might surely do something better than spoil the look of the face of his own country. Architecture was pre-eminently a constructional art, and consequently it was of the utmost importance that any man who wanted to become an architect should make himself sufficiently acquainted with the subject, so that he could build with satisfaction to himself and to those who used the edifice. The science of construction was statics, and every man who professed to be an architect should learn sufficiently of statics to be able to gauge the security of walls against the pressure of the wind, water, and earth, and even against the pressure of goods stowed against them that had an inclination to slide. He must know the pressure that was exercised by vaults, domes, and arches, and learn how those might be properly abutted, as well as understand how

to prevent walls, piers, and columns becoming forced out of the vertical. Besides statics, he had to learn the force and strength of the different materials that were used. Unless a man knew the outlines of construction, he could hardly be called an architect, although he might be an admirable designer and planner. The great thing a man who could plan and construct ought to know was how to make the necessary portions of the building he was putting up tell the tale they were required to tell. He was sorry to say that a great deal too little attention was paid to that matter in England, for they saw all kinds of incongruous ornaments and decorations put on all sorts of places. It was probably ten times more difficult to get a thing to look well that was simple than if it was ornamented. Great ornateness was a mistake, for it was never equal to the perfection that could be obtained by the greatest possible simplicity. In every architectural epoch of importance the world had known some buildings were erected that had been the admiration of succeeding generations, and now all persons of culture and wealth would as soon think of being ignorant of the great writers of their own countries as not to have seen Rome, Athens, Italy, and Florence. He did not know we were very much inferior in Gothic days in our works to the French; but he was afraid in his time there had not been so many great buildings put up that would bring persons to see them from all parts of the world. One of the things that seemed to be forgotten was that architecture was a constructive art, and sufficient pains were not taken to see how the elegancies of proportion and the beauties of form could be added to our buildings. Those who felt they had divine genius for architecture should use that precious gift properly, and let no labour and no difficulty overcome their desire to make themselves skilful, and to confer such an inestimable boon on their country as to be able to raise buildings which would attract people from all parts of the world.—On the motion of Mr. W. Hale, seconded by Mr. W. Henman, a vote of thanks was accorded Professor Aitchison for his address.

**EXETER DIOCESAN ARCHITECTURAL AND ARCHÆOLOGICAL SOCIETY.**—Bishop Kestell-Cornish, formerly Bishop of Madagascar, presided at a meeting of this Society on Friday, when a paper was read by Canon Edmonds on the length of the Norman nave of Exeter Cathedral. The lecturer said Dr. Oliver, who had left them much valuable information, was of opinion that the original Norman part of the cathedral stopped at the north porch, and that Grandisson added further pillars westward. There were proofs of Norman work in the nave. A document of 1283 showed that Grandisson built the chapel of St. Ragsund in the north side of the big west door, and in order to do so had knocked down the original Norman wall. From the various proofs they had, Canon Edmonds contended that the present nave of the cathedral was precisely the length of the original Norman building. A discussion followed in which the speakers generally agreed that the opener's conclusion was correct.

**ROYAL INSTITUTE OF BRITISH ARCHITECTS.**—At a special general meeting of this Institute held on Monday evening, the chairman, Mr. W. M. Fawcett, M.A. (vice-president), moved that, subject to Her Majesty's gracious sanction, the Royal Gold Medal for the promotion of architecture be presented to Professor Aitchison, R.A. The motion having been seconded by Mr. H. L. Florence (vice-president), it was resolved *nem. con.* "That, subject to Her Majesty's gracious sanction, the Royal Gold Medal for the promotion of architecture be presented this year to Professor Aitchison, R.A." A business meeting was held immediately afterwards, Mr. W. M. Fawcett, M.A. (vice-president), in the chair. The chairman announced that the Council had resolved to increase the value of the Owen Jones Studentship from £50 to £100, and that the holder of the studentship would be required to make a tour extending over six months, such tour to be devoted to the improvement and cultivation of his knowledge of the successful application of colour as a means of architectural expression.

**SHEFFIELD SOCIETY OF ARCHITECTS AND SURVEYORS.**—The monthly meeting of members of this society was held on Tuesday evening. A lecture was delivered by Mr. Charles Castle, of Sheffield, one of the members, on "Timber for Construction and Decoration." He outlined some of the many vicissitudes through which

timber trees pass from birth to maturity, and explained how environment almost changed the species. Mr. Castle rapidly passed in review some of the ordinary woods of commerce, such as spruce, pitch pine, yellow pine, red pine, &c. Then teak, Kauri, Oregon pine, mahogany, oak and canary wood, pointing out their various characteristics, and showing in detail many interesting facts in relation to them. Some good specimens of the combination of various woods for decorative purposes were then shown. The lecturer said that teak was one of the most reliable and beautiful of woods. It had the advantage of standing artificial drying without casting, and it was most durable. Kauri was a wood also much praised for its beauty by Mr. Castle, who said that its natural colour was like plain satinwood, and used in decoration it would alternate with any darker wood. It was strongly recommended for first-class floorings, staircases, hand-rails, and shop-fronts. The various kinds of mahogany were referred to, and samples shown. The immense increase in the importation of African mahogany was noted. The amount of 200 tons in 1886 had increased to the enormous extent of 40,000 tons in 1897.

**SOCIETY OF ENGINEERS.**—At a meeting of this society, held at the Royal United Service Institution, Whitehall, on Monday evening, Mr. W. Worby Beaumont, president, in the chair. A paper was read by Mr. William Fox, M.Inst.C.E., entitled "Reservoir Embankments: with Suggestions for Avoiding and Remedying Failures." The author mentioned several instances where difficulties had arisen, and the means adopted to overcome them. He then described the depth and form of the foundation for the puddle trench, showing how springs might be dealt with by means of vertical pipes. He referred to the width of the trench when to be refilled with concrete or puddle, and gave the proportions in both lime and cement concrete. The author gave his experience with reference to the material used and mode of construction of the embankment; particulars of the width of the puddle wall; the distribution of material on each side, and width of the top; the desirability of the construction of stone or burned ballast toes under certain conditions; the mode of working the clay and of forming the layers of embankment, and the protection of the inner slope from the wash of the waves. In connection with the Den of Ogil Reservoir at Forfar, the author described the way in which a leak through the concrete was traced and repaired. The Dowdeswell Reservoir Embankment, which was made to a great extent of clay, was provided with burned ballast toes to within 20ft. of top bank level, which had the desired effect of preventing any slipping. The Monkswood Reservoir was also made of very treacherous material, and to prevent slipping, rubble stone toes were adopted. This had the desired effect to a certain extent, but it was found necessary to use more rubble stone than originally intended, and to flatten the outside slope. These precautions were taken immediately signs of a slip became visible, and successfully prevented any further movement.

The vicar of St. Crantock, near Newquay, has issued an appeal for help in restoring the fine old church in his parish. He states that the building has been ruinous these many years, and unless something is soon done it may suffer disastrously. The estimated cost of restoration is £2,000, towards which about £750 is available.

The Edinburgh Architectural Society met on the 2nd inst., the president, Mr. W. Nicholson Cumming, in the chair, when Mr. A. Hunter Crawford delivered a lecture on "Steam-Heating." The lecturer adopted the plan of discussing the solution of an actual problem before his audience, illustrating the subject by sketches and a working model, showing a combined method of steam-heating and domestic hot-water supply.

Mr. G. Salvati, the well-known dealer in Venetian glass, of 213, Regent-street, shot himself on Friday night in his shop after the last of the employes had left. Upon the premises being entered the following morning, he was found lying dead with a bullet-wound in his forehead. A few weeks ago Mr. Salvati turned his business into a limited liability company. The evidence given at the inquest showed that deceased, who was 55 years of age, had recently suffered from insomnia, and although a wealthy man, was under the delusion that he was beset with pecuniary difficulties. A verdict of suicide during temporary insanity was returned by the jury.

## Building Intelligence.

**DERBY.**—Holy Trinity Parish Church, situated in the London-road, and opposite the Royal Derbyshire Infirmary, was recently condemned as unsafe by the professional adviser of the vicar and churchwardens, Mr. Charles E. Hewitt, architect, of Queen's-road, Brighton, who has been consulted from time to time during the last three or four years. A survey made in November, 1897, showed that there had been a further subsidence of the building, and that, in addition to the tower being very weak and about 9in. out of the perpendicular, the body of the church was in such a dangerous condition, owing to the roof, that it was necessary to prevent what might have become a general collapse of the whole structure. A specification and plan were prepared and a faculty obtained, and the work, which was entrusted to Mr. R. Weston, builder, of Derby, under the superintendence of the architect, was completed at the end of last month. The work undertaken included (a) taking down about 34ft. of the tower; (b) securing the roof trusses (the span of the roof being 45ft.) to prevent them becoming further out of the perpendicular; (c) the main walls of the body of the church, on which the roof trusses rest, have been tied together with steel tie-rods to prevent spreading; (d) the west walls of the nave have been shored, and also the windows over which the roof trusses rest. These measures, adopted for the safety of the public and the congregation, are only of a temporary nature, as the vicar and churchwardens are contemplating the erection of a new church on the same site. This church was struck by lightning in June, 1853.

**LIVERPOOL.**—The city surveyor of Liverpool, Mr. George Shelmerdine, reported on Friday to the finance committee of the corporation of that city as to utilising the site of St. George's Church, which occupies the site of the ancient castle, and which is about to be demolished. He said there were 115 vaults underneath the body of the church. The majority of the pits had wooden lid coverings, which in many instances had fallen in, and no earth covered them. The vaults being in a confined space, the atmosphere was necessarily putrid, and was certainly dangerous to the health of persons entering them. The surveyor said he attributed his recent illness to his inspection. The remains ought to be removed and reinterred. The trustees' surveyor (Mr. Bradbury) had stated that it was the intention of the trustees to take down and dispose of everything to the floor-level of the church, leaving the lofty spire and arches of the vaults and the foundation for the corporation to remove. Mr. Shelmerdine reported that the cost of removing these would far outweigh the value of the materials. The site comprises an area of about 1,090 square yards, and, with the cabstand on the south side, there was at command a site unequalled in the centre of the city available for the erection of a building for public purposes, and one which would be found capable of fine architectural treatment. He had prepared a draft of a plan for a proposed council-house on the site, containing lord mayor's, luncheon and tea, committee, and retiring rooms, &c. Consideration of the report was postponed.

**MILTON, PORTSEA.**—The new workhouse infirmary and nurses' home at Milton have been formally opened. The infirmary buildings run north and south, and comprise two ward pavilions, nurses' home, and kitchen block. The ward pavilions afford accommodation for 60 male and 60 female patients, and contain on each floor a ward 76ft. by 24ft., two isolation wards, nurses' duty room, linen store, bath-room, lavatories, small lift, &c. The ground floor is kept up 3ft. above ground line. The upper floors throughout are of fireproof construction. At the south end of each of the large wards there is a balcony, with external staircases affording a second exit in case of fire or panic. The nurses' home is a three-story building, facing south, and contains matron's apartments, nurses' dining and drawing rooms, linen stores, &c., and 21 bedrooms. The kitchen is fitted with plant and appliances to cook for the whole of the patients, both in the old and new hospital blocks, and also in the imbecile wards, and is centrally situate. In the basement are two 10H.P. steam boilers. The buildings throughout are lighted by electricity. The cost of the works, including road-making, has been approximately £22,000, and of the furnishing £2,000. Mr. A. H. Barnes has acted as clerk of

works, and the works have been carried out from the designs of Mr. C. W. Bevis, F.R.I.B.A., architect, of Southsea.

**PETERBOROUGH.**—At the last meeting of the committee for the restoration of Peterborough Cathedral, held on Thursday in last week, Mr. G. F. Bodley, A.R.A., the newly-appointed architect, was present, and reported on his recent inspection of the west front and other parts of the cathedral which are showing signs of weakness. He stated that the measures already taken confirmed the wisdom of the course suggested and carried out on the north side by his predecessor, the late Mr. J. L. Pearson, R.A. Happily, the great arch on the south side of west front was not in so bad a state as the northern one, and he hoped they might be able to keep it up. Mr. Bodley thought that by carefully grouting with liquid grout from the top of the arch, and other means, much might be done to strengthen it; but it had yet to be seen how far this would be sufficient. The whole of the front had gone considerably out of the vertical, and was a good deal shaken, and the gable end was so weak that he feared it must be reset. The walling behind the ashlar face was in so bad a state that he thought no method of strengthening the wall was here practically possible, though he lamented the necessity of its being taken down. The stone was so perished and the masonry so shaken that it would not be feasible to back the existing wall of the gable and get sufficient strength for it. This work should be taken in hand at once. Mr. Bodley also drew attention to urgent repairs needed in the walls of the eastern chapel. The estimated cost of the whole of the work was £8,659, and that which it was urgent to undertake at once would cost £2,739. It was decided, on the proposal of the Marquis of Exeter, to proceed with the more urgent work, and to hold a public meeting on behalf of the restoration fund at Peterborough on April 20.

**ST. ANNE'S-ON-SEA.**—The new clubhouse of the Lytham and St. Anne's Golf Club was formally opened on Saturday by the Marquis of Lorne. The links are situated between the railway stations of St. Anne's and Aresell. The circuit of the links is  $3\frac{1}{2}$  miles, and the area covers some 150 acres. The club has expended over £3,000 on the links alone, while the Gothic clubhouse, built from the designs of Messrs. Woolfall and Eccles, of Liverpool, has cost £8,000, and the furnishing an additional £2,000. The house comprises entrance-hall, locker-rooms, clubrooms, dining-hall, ladies' clubroom and dressing-rooms, billiard-room, baths, lavatories, offices, and steward's service.

**WARRINGTON.**—The foundation-stones of the new workhouse infirmary were laid on Thursday in last week. The infirmary will stand upon five-and-three-quarter acres of land immediately behind the present workhouse premises. The present contracts deal with three blocks of buildings, standing 70ft. apart, but connected on each floor with open-air corridors, 10ft. wide. The central will be the administrative block, three stories high, and the two outer blocks will be ward pavilions, each two stories high. Under the whole of the buildings there will be a basement for access to heating and water-pipes. The administrative block will give accommodation on the ground floor for the medical officer, head nurse, dispensary, waiting-room, nurses' sitting and dining rooms, linen stores, and on the first and second floors there will be bedrooms for the nursing staff, each floor being fitted with baths, lavatories, and closets. The other two blocks will be ward pavilions, one for males and the other for females, each accommodating 92 beds, or a total of 184. In each block there are two wards of 24 beds, two wards of four beds, and six wards of three beds each, and each set of wards has separate baths, lavatories, and closets. There are also ward kitchens, linen rooms, separation lobbies, and lifts. All wards will be heated by open fireplaces, or central open-fire Musgrave stoves, augmented by hot-water pipes. The floors throughout will be fireproof, of Messrs. Homan and Rogers' construction, and in addition to stone staircases there will be also an outer stair of iron in each case. The contract entered into with Mr. C. W. Davenport, of Stockton Heath, including the boundary walls, amounts to £23,266. Externally, hard grey brick will be used, with a sparing allowance of terracotta and red pressed brick dressings. The works have been designed by Messrs. William and Segar Owen, architects, of Warrington.

## Engineering Notes.

**ABERLADY AND GULLANE RAILWAY.**—The new railway connecting Aberlady and Gullane with the main line of the North British Railway will be opened for traffic on April 1. The line is only  $4\frac{1}{2}$  miles in length, but it will open up an attractive district of East Lothian. The new line, which is single throughout, leaves the main line a mile and a half to the east of Longniddry junction. There is an intermediate station at Aberlady. The railway will be worked by the North British Railway Company, who are asking sanction this session to the extension of the stipulated time for the completion of the line from Gullane station to join the North Berwick loop line near Williamston Farm.

**MANCHESTER.**—The Lancashire and Yorkshire Railway Company will open their new branch line to the Manchester Ship Canal for merchandise traffic on Monday, the 28th inst. The work has been in progress since November, 1895. The new line is for the most part carried underground, by means of a series of tunnels. On the whole length of the line there were buildings, chiefly shops and dwelling-houses, which had to be demolished. The tunnelling throughout is faced with blue Staffordshire bricks. The height of the tunnels is from 17ft. to 23ft., and the depth of the line below the surface varies from 35ft. to 45ft. Some of the walls are 7ft. and others as much as 12ft. thick. One difficult feature was the making of a tunnel between the London and North-Western Railway and Regent-road. The large gasholders and the mains leading from them along West Egerton-street had to be carefully passed. Then also a tunnel had to be made under the North-Western line, which itself passes under West Egerton-street by means of a bridge. Mr. W. B. Worthington is the chief engineer of the Company, and Mr. L. Franklin has acted as resident engineer. Mr. Thomas Wrigley, of Middleton Junction, was the contractor.

**PETERHEAD.**—The annual report of the engineers in chief for the new harbour of refuge, Messrs. Coode, Son, and Matthews, of 9, Victoria-street, S.W., states that during the past year the south breakwater was extended 105ft. A further length of 45ft. has been brought up to low-water level. Mr. E. Raban, director of works, in a memorandum on the report, says progress continues to be made with the south breakwater and barge harbour. The quarry has been further opened out, and the workyard, buildings, railway, and plant properly maintained. A new locomotive tank engine has been supplied. The daily average number of convicts employed on the works during the year has been 237, as against 241 shown in the previous year's report. The annual report of the surveyors, with measurements and valuation of the work done on the basis of Sir John Coode's original estimate, has been received. The result is given in the following extract from that report:—"As far as can be seen at present, the original estimates will not be exceeded. The works do not progress so rapidly as possibly they might, owing to the dearth of convicts. This is, no doubt, a satisfactory circumstance to notice. At the same time, the want of progress will tend to increase the total cost."

**PORT VICTORIA.**—The South-Eastern Railway Company have completed the reconstruction of Port Victoria pier, the terminus of the Hundred of Hoo branch, which was temporarily closed for traffic in October, 1896, on account of the structure being considered unsafe to bear the strain of trains. The pier has been strengthened by the addition of 324 new piles, the largest of them being 70ft. long and 17in. square. The piles on the riverside of the pier have been left standing 6ft. above the deck level, in order to prevent the sponsons of Royal yachts from settling on the edge of the pier when lying alongside at high water. The whole of the old piles have been left in, the new piles being driven alongside of them and being bolted to them by  $1\frac{1}{2}$ in. bolts. To prevent the inroads of the teredos, which have eaten away the old piles, the new piles have been sheathed with copper for a height of 4ft. above mud level. The plan of the superstructure—platform and buildings—has been entirely altered, the rails being now laid on the inner side of the pier, facing the Isle of Grain. A covered way has been provided, and the length of the platform has been extended to 500ft. The works have been carried out by Messrs. John Aird and Sons, of Lambeth.

CONTENTS.

Craft Independence ... 331  
 Model Specifications.—III. ... 331  
 Architecture at the Royal Scottish Academy ... 333  
 Wrought Iron and Steel in Constructional Work.—XXXIV. ... 334  
 Acetylene Gas; the New Illuminant ... 336  
 Column Tests ... 337  
 The Surveyors' Institution ... 337  
 Architects' Benevolent Society ... 338  
 Ornamental Bricks and Tiles ... 333  
 Useful Items for Builders, Plasterers, Painters, Paperhangers, &c. ... 338  
 Schools in the States ... 340  
 Obituary ... 340  
 Professional and Trade Societies ... 341  
 Building Intelligence ... 342  
 Engineering Notes ... 342  
 The Building News Directory ... 1x.  
 Our Illustrations ... 343  
 Competitions ... 343  
 Correspondence ... 362  
 Intercommunication ... 362  
 Water Supply and Sanitary Matters ... 362  
 Legal Intelligence ... 363  
 Our Office Table ... 363  
 Meetings for the Ensuing Week ... 364  
 Trade News ... 365  
 Latest Prices ... 365  
 List of Competitions Open ... 366  
 List of Tenders Open ... 366  
 Tenders ... 370

ILLUSTRATIONS.

THE ROYAL MASONIC INSTITUTION FOR BOYS, BUSHEY.—STUDIES OF ANIMAL LIFE, TREATED FOR DESIGN.

Our Illustrations.

ROYAL MASONIC INSTITUTION FOR BOYS, BUSHEY.

It is intended to erect new schools at Bushey, Herts, as a memorial of the centenary of this institution, the requirements having outgrown the existing buildings at Wood Green. With the general approval of the subscribers, the board of management purchased the Bushey Grove Park Estate of about 67 acres in extent, and has devoted much labour to its development. The site is an admirable one, having an area of 65 acres, with roads on all sides, the general soil being loam with pebbles therein, and possesses a level plateau, standing high, upon which it is proposed to erect the buildings. Having given full consideration to the future requirements as well as the immediate necessities of the institution, with the valuable assistance of W. Bro. Rowland Plumbé, F.R.I.B.A., P.G. Supt. of Works, the board prepared a schedule of conditions and accommodation required, and invited six firms of architects to submit designs in a limited competition. The designs were most carefully adjudicated upon by the assessor, whose award met with the unanimous approval of the board, and the plans placed first in order of merit were submitted to the Quarterly Court in January last. The authors of the designs were found to be Messrs. Gordon, Lowther, and Gunton, of Finsbury House, London, E.C., and these brethren are now engaged in preparing the working drawings and quantities. It is expected to have these completed and the work on the buildings commenced in the autumn. The designs show a complete arrangement for a school of 500 boys; but it is proposed to build dormitory accommodation for 400 only at present. The administrative offices, halls, &c., will be adapted for the greater number, so as to avoid expense in alterations, &c., in the future. It will be seen from the accompanying plan that the general scheme is quadrangular, placed so as to secure the best possible aspects, the administrative block, with its central tower, occupying the principal or south-west side and facing the main road and entrance. This block contains the museum and library. The Educational block, with its separate quadrangle, containing the assembly-hall, the music-school, the various arts and physics schools, classrooms, together with the chapel and head-master's residence adjoining, are placed on the north-west side. The north-east side is occupied by the dining-hall, the kitchen and service department, with its separate courtyard; and beyond this the technical schools, swimming-bath, gymnasium, and five-courts, &c., are placed. The south-east side is left partially open for the present, with a view to the erection in the future, if necessary, of an additional residential block. The residential blocks are placed at each corner of the main quadrangle, and arranged to accommodate 100 boys, each block comprising two houses with day-schools, dormitories, and masters'

and service-rooms, complete. A main feature of the design is that all the principal blocks are connected by cloisters and subways, and are provided for domestic service. It is proposed ultimately to erect a sanatorium for 50 boys, as well as an infirmary for 25 cases, the former at the extreme north corner of the site, so as to be placed as far as possible from the school building, and the latter at the extreme south, each having separate approaches from the main roads. The playing-fields and tennis-courts are placed to the south and west of the site, and the former are overlooked from the master's residence. The heating to the buildings will be by means of hot water on the low-pressure system, with ventilating radiators for the admission of warm, fresh air, in conjunction with Tobin's tubes, the exhaust ventilation being effected by means of fans placed in the turrets, and connected with horizontal trunks in the floors and ceilings, and rising flues in the walls, fitted with automatic valves. The lighting will be by means of electricity, which will be generated on the premises. The drainage will be on the duplicate system, well intercepted and ventilated, and arranged so as not, in any case, to pass under the residential portion of the buildings. The buildings are designed in a plain, scholastic style, mainly 15th-century in character, having red brick facings, stone dressings, and slated roofs of a green tint. Great reliance has been placed upon the grouping of the various blocks for the general effect, the main entrance being distinguished by a central clock-tower, and the residential blocks at each corner of the main quadrangle by square towers containing the water-storage tanks. A further and important feature of the principal front will be the chapel, which will be erected at the cost and under the immediate supervision of W. Bro. Charles E. Keyser, patron and treasurer of the institution. This munificent example, the board hopes, may be followed by others, and thus economise the very limited capital funds of the institution. An opportunity is also afforded to lodges, chapters, or brethren to undertake certain structural embellishments, which will add grace and dignity to buildings of intense usefulness, and of which there is every reason to believe the whole Craft will be proud.

STUDIES OF ANIMAL LIFE TREATED FOR DESIGN: NATIONAL SILVER MEDAL DRAWINGS, BY JOHN BROWNSWORD.

CONTINUING the series of bird and quadruped studies which we commenced on Jan. 7 last, we give to-day a sheet of very spirited drawings of a suggestive character from the brush of Mr. John Brownsword, of the Royal College of Art. The aim of the artist has been to present the subjects in a strictly natural way as records which shall be ornithologically and zoologically correct, but at the same time so contrived as to offer ideas for adaptation and development in a conventional manner for decorative design. This intention seems to have been very well managed, and for this purpose these sketches cannot fail to be valued by our readers.

Mr. T. B. Grierson, chief engineer of the Dublin, Wicklow, and Wexford Railway, has been appointed engineer and locomotive superintendent of the Lancashire, Derbyshire, and East Coast Railway.

The formal reopening of the grand organ in St. George's Hall, Liverpool, after being closed for improvements and rearrangements for about five months, took place on Saturday. The alterations have been carried out by Mr. Henry Willis, of London, at a cost of upwards of £3,000.

The newly-erected diphtheria block, which has been added to the Delancey Fever Hospital at Cheltenham, was opened on Saturday afternoon. The new block, which is isolated from the main building, consists of three wards for two beds each, a convalescent ward, nurses' room, bath-room, stores, &c., arranged round a corridor 6ft. wide. Messrs. Middleton, Prothero, and Phillott, of Cheltenham, were the architects, and Messrs. Collins and Godfrey, of Tewkesbury, the contractors. The total outlay will reach £2,500.

Messrs. Galbraith and Church, the engineers of the extension from Wadebridge to Padstow of the North Cornwall Railway, report that great progress is being made with the undertaking. Some three-fifths of the total excavation is done, and nearly 3½ miles of the line formed. The masonry and bridges are well forward, and a considerable number of the cast-iron cylinders for the viaduct piers are on the ground. The station-house at Padstow is about half-built, and platform walls are in hand.

COMPETITIONS.

ARMLEY.—In a limited competition for chapel and Sunday-schools for the Methodist Free Church, Armley, near Leeds, the design submitted by Mr. Walter Hanstock, of Leeds and Batley, has been placed first, and its author will design and carry out the buildings.

BIRMINGHAM.—The plans prepared by the six selected local architects in competition for the new lunatic asylum which the Birmingham Corporation propose to erect at Holly Moor, near Rubery, have been deposited at the Council House in that city. The names of the competitors are: Messrs. Cossins, Peacock, and Bewlay, Colmore-row; Messrs. Mansell and Sons, Colmore-row; Messrs. Ingall and Sons, Temple-row West; Messrs. Cross, Brooks, and Nicholls, Temple-row; Mr. Frank B. Osborne, Bennett's-hill; and Messrs. Martin and Chamberlain, Colmore-row. Mr. G. T. Hine, F.R.I.B.A., of Parliament-street, S.W., has been appointed as assessor to the asylums committee.

LEICESTER.—In the competition by local architects for laying out the new cemetery on the Gilcross estate, the corporation have adopted the report of their assessor, Mr. John Belcher, F.R.I.B.A., of Hanover-square, W., and have awarded the first premium of £50 to Messrs. Goddard and Paget, the second, £30, to Mr. Stockdale Harrison, and the third of £20 to Mr. Chas. Kempson. The original estimate of Messrs. Goddard and Paget was £27,573; but the premiated plans have been revised and reduced in cost to £20,797, and with these modifications will be carried out.

WESTMINSTER.—The Poster competition in connection with the forthcoming Art Metal-Work Exhibition, to be held at the Royal Aquarium in May and June, was settled last Friday. Forty-three designs were received, and the prize was unanimously accorded to the design submitted by Mr. W. Dundas, Carlyle Studios, King's-road, Chelsea. The composition represents the Jack of Clubs holding a *repoussé* bowl, the figure being strikingly designed, and standing in front of a wrought-iron grille enriched with trefoils. Two other designs, which, as drawings, were in many ways superior, but less successful as posters to be seen at a distance and in the street, were awarded hon. mention. We shall probably illustrate them, with the chosen design, as all three are of exceptional interest. The judges who made the award were Messrs. George Frampton, A.R.A., Lewis F. Day, Maurice B. Adams, F.R.I.B.A., George Haité, Josiah Ritchie, managing director of the Aquarium Company; and Professor Banister Fletcher, J.P., chairman of the council of the Art Metal-Work Exhibition. During the week the Duke of Westminster has joined this council.

CHIPS.

Mr. George Gammon Adams, F.S.A., the well-known sculptor and medallist, died on Friday last at his residence, Acton Green Lodge, Chiswick, aged 77 years.

A theatre is being built at the corner of South-place, Kennington Park-road. Built in the Italian Renaissance style of white Portland stone, it will have an entrance frontage of 160ft.; there will be a marble staircase 29ft. wide leading to a crush-room, the roof of which will be supported by marble columns. There will be seating accommodation for 2,500 persons.

The Ben Brierley Memorial, which is to be placed in Queen's Park, Harpurhey, Manchester, will be completed and ready for unveiling about the middle of April. The statue will be 7ft. 8in. in height, and the pedestal and base 9ft., a total of 16ft. 8in. It is to be of whitened Portland stone. The sculptor is Mr. John Cassidy, of Manchester.

The city council of Oxford have purchased land in Blue Boar-street in that city, and are about to erect thereon a residence for the chief constable at an estimated cost of £1,250. The site is at the rear of the new municipal buildings, and will communicate with them.

The amount provided in the 1898-99 estimates for continuing the work of mosaic decoration in the central hall at Westminster is £1,000. The next panel to be dealt with is that over the entrance to the House of Commons corridor, for which Sir Edward Poynter has drawn a cartoon of St. David in harmony with the representation of St. George opposite. The subjects for the other vacant panels will be St. Andrew and St. Patrick, for which the sketches prepared by Mr. Albert Moore, and exhibited for a considerable period at South Kensington, will probably be utilised.





# ROYAL MASONIC INSTITUTE FOR BOYS BUSHEY · HERTS.

SELECTED DESIGN BY · MESSRS GORDON LOWTHER & CUNTON ARCHTS

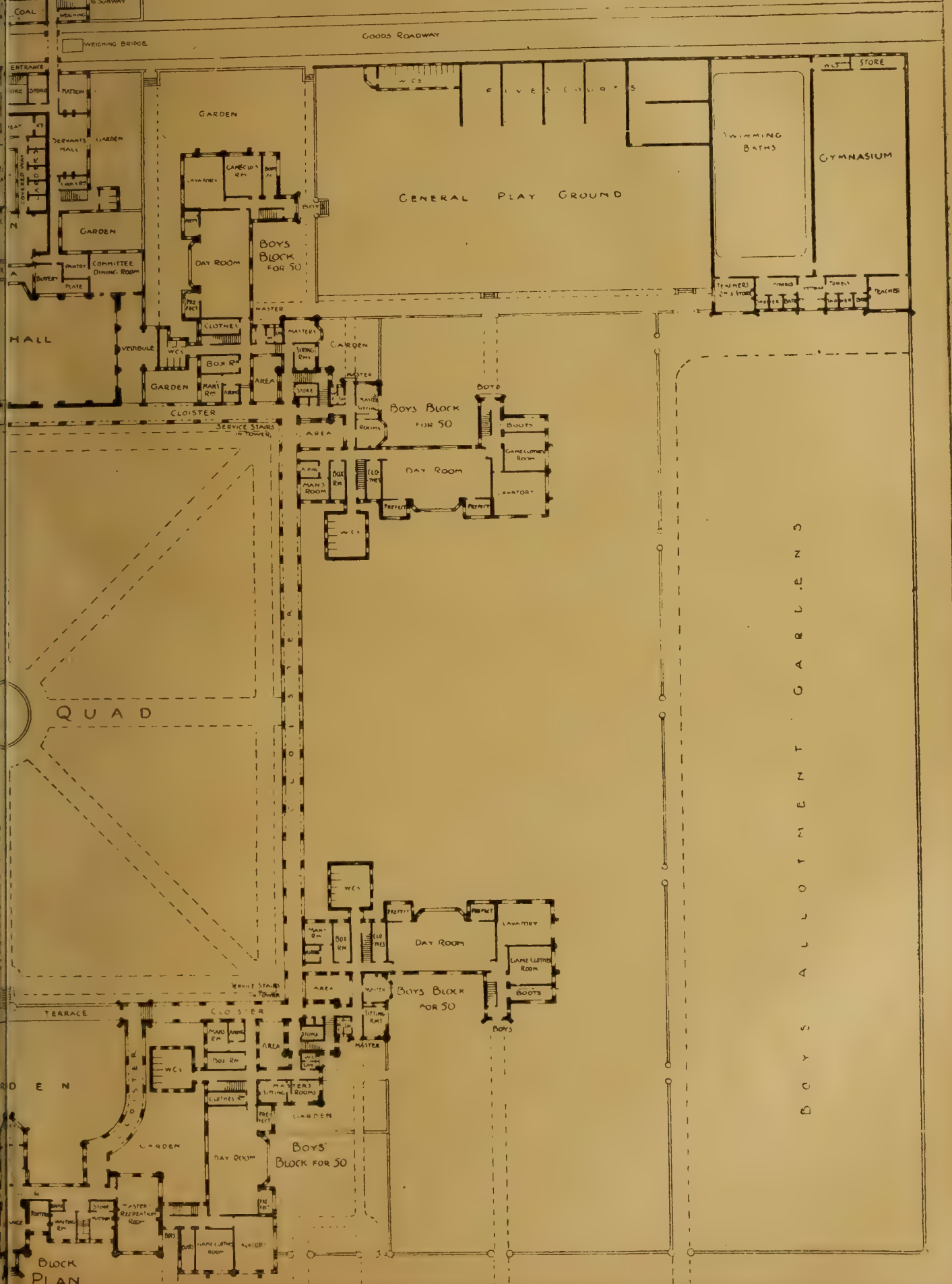

S O U T H E A S T C O R I D O R

Block PLAN

## TO CORRESPONDENTS.

[We do not hold ourselves responsible for the opinions of our correspondents. All communications should be drawn up as briefly as possible, as there are many claimants upon the space allotted to correspondents.]

It is particularly requested that all drawings and all communications respecting illustrations or literary matter should be addressed to the EDITOR of the BUILDING NEWS, 332, Strand, W.C., and not to members of the staff by name. Delay is not unfrequently otherwise caused. All drawings and other communications are sent at contributors' risks, and the Editor will not undertake to pay for, or be liable for, unsought contributions.

Cheques and Post-office Orders to be made payable to THE STRAND NEWSPAPER COMPANY, LIMITED.

## TERMS OF SUBSCRIPTION.

One Pound per annum (post free) to any part of the United Kingdom; for Canada, Nova Scotia, and the United States, £1 6s. 0d. (or 6dols. 30c. gold). To France or Belgium, £1 6s. 0d. (or 3fr. 30c.) To India, £1 6s. 0d. To any of the Australian Colonies or New Zealand, to the Cape, the West Indies, or Natal, £1 6s. 0d.

## ADVERTISEMENT CHARGES.

The charge for Competition and Contract Advertisements, Public Companies, and all official advertisements is 1s. per line of Eight words, the first line counting as two, the minimum charge being 6s. for four lines.

The charge for Auctions, Land Sales, and Miscellaneous and Trade Advertisements (except Situation advertisements) is 6d. per line of Eight words (the first line counting as two), the minimum charge being 4s. 6d. for 40 words. Special terms for series of more than six insertions can be ascertained on application to the Publisher.

Front-page Advertisements 2s. per line, and Paragraph Advertisements 1s. per line. No Front-page or Paragraph Advertisement inserted for less than 5s.

Advertisements for the current week must reach the office not later than 3 p.m. on Thursday. Front-page Advertisements and alterations in serial advertisements must reach the office by Tuesday morning to secure insertion.

## SITUATIONS.

The charge for advertisements for "Situations Vacant" or "Situations Wanted" is ONE SHILLING FOR TWENTY-FOUR WORDS, and Sixpence for every eight words after. All Situation Advertisements must be prepaid.

## NOTICE.

Bound copies of Vol. LXXII. are now ready, and should be ordered early (price Twelve Shillings each), as only a limited number are done up. A few bound volumes of Vols. XXXIX, XL, XLI, XLII, XLIII, XLIV, XLV, XLVI, XLVII, XLVIII, XLIX, L, LI, LII, LIII, LIV, LV, LVI, LVII, LVIII, LIX, LX, LXI, LXII, LXIII, LXIV, LXV, LXVI, LXVII, LXVIII, LXIX, LXX, LXXI, LXXII. may still be had, price Twelve Shillings; all the other bound volumes are out of print. Most of the back numbers of former volumes are, however, to be had singly. Subscribers requiring any back numbers to complete volume just ended should order at once, as many of them soon run out of print.

ARCHITECT. (We know of no good book; but inquire of Batsford, 94, High Holborn, W.C.)

RECEIVED.—T. K. and Co.—B. A. W.—P. H. R.—G. T. G.—L. M. W.—L. A. E.—R. K. and Co.—S. H. G.

## "BUILDING NEWS" DESIGNING CLUB.

## SIXTH LIST OF SUBJECTS.

F.—A Bungalow for a Gentleman.—The site for this small residence is on the side of a well-wooded hill a few miles from London, and the building is intended for summer occupation. The incline from east to west is 1ft. in 10ft., and the prospect, of course, is over the valley below. The approach is from the north. The base of the building is to be in red brick. The whole of the accommodation is to be on the ground floor, excepting a belvedere smoking-room, which is to be located over the central hall, out of which the reception and best bedrooms are to be approached. This hall is not to be treated as a sitting-room. The building must be compactly contrived in a simple and suitable way, remembering that a bungalow is not a baronial hall. The living-room is to be 24ft. long by about 18ft. wide. The drawing-room 16ft. by 13ft., or of that area. A billiard-room for a full-sized table. Four best bedrooms, and two more for female servants. A man's room is to be provided, and to be suitably isolated. A bathroom, lavatory and cloakroom, &c., and a box-room to be provided, and space for bicycles, golfing-irons, &c., is to be accommodated. There should be a small cellar, and the fall of the ground may suggest a half-basement; but the scheme is left to the competitors. Along the garden side of the house on the west front a terrace 12ft. wide is to be planned. The kitchen and offices to be appropriate for such a dwelling. Materials, brick and rough-cast. Tiled roofs. Scale, 8ft to the inch. Style, suitability. Plans, two elevations, section, and view. If really necessary to work the drawings nicely into one sheet, the scale of plans may be 16ft. to the inch.

DRAWINGS RECEIVED.—"Stanley," "John Bull," "By Go," "Angler," "St. Catherine," "Chuckle," "Phantom," "Swan," "Saxon," "Suburb," "Gib."

## Correspondence.

## THE GOVERNMENT AND THE NEW PUBLIC OFFICES.

To the Editor of the BUILDING NEWS.

SIR,—The debate in the House of Commons last Friday shows that the Government and the House

are taking a most laudable interest in the subject of the designs for the new public offices.

Mr. E. Morton asked, "How is the choice of designs made?" And Mr. Akers-Douglas replied that "The Government had not got so far as that yet."

I think, Sir, that it is generally understood that the Office of Works will lay down the plans of the new offices (as they are so well able to do), and that outside architects will be asked to clothe those plans with architecture worthy of the position. And it will be of very great interest to the profession at large to know, in good time, in what manner this outside help is to be invoked!

A rumour is afloat that the Office of Works will communicate with the Royal Institute of British Architects, with a view to appoint some one architect to so clothe the skeleton of the Office of Works; in other words, that it will be left to the council of the R.I.B.A. (because not a word of this arrangement will be communicated to the general body of members until the whole arrangement is cut and dried) to nominate and secure the appointment of the particular gentleman whom that council may delight to honour.

If this rumour has a foundation in fact, no time should be lost by the general body of architects in this country in conveying to the proper quarter (i.e., the Government) the fact that such an arrangement will not be fair either to the public or to architects. Another opportunity (notwithstanding past failures) should be afforded for a public competition for these new offices, and in that way and that way alone will the final result be satisfactory. This will give a fair chance to the members of Council of the R.I.B.A. to show their superiority of knowledge of design as compared with the rest of the profession, and it may secure a design from some unknown man which may redeem the past, and give Whitehall a structure or structures in every way a credit to the architectural world.

At all events, Sir, it is now left for architects to assert their fair rights; but if they do not care to take the trouble to do that, then they have simply to await the announcement of the decision that Mr. A. B., member of Council of the R.I.B.A., has been selected by the Government to prepare designs for the new public offices to be erected in Whitehall. Personally, I have no other interest in the matter than to secure what I may term "fair play."—I am, &c.,

WM. WOODWARD.

13, Southampton-street, Strand, March 9.

## Intercommunication.

## QUESTIONS.

[1911].—Bending Moment.—I shall be obliged if someone will define the meaning of the term "bending moment," and also say whether a mechanical moment and a bending moment are synonymous terms?—IGNORAMUS.

[1912].—Painting Galvanised Iron.—When galvanised iron is painted with paint made with white-lead, is a galvanic action set up and the durability of the iron thus lessened?—C. F. M.

[1913].—Furnishing Common Lodging-Houses.—Can any of your numerous readers give me particulars and cost of furnishing the wards or cubicles for married couples and single men and women respectively?—INQUIRER.

The annual dinner of the Birmingham Clerks of Works' and Builders' Foremen's Association was held at the White Horse Hotel, Congreve-street, in that city, on Tuesday week. County Alderman John Bowen, in responding to the toast of "The Honorary Members," congratulated the association upon its success, and which must be of great service to the building trade of Birmingham, and deserved the support of the Master Builders' Association. Mr. Whitall, vice-president, endorsed the views of Mr. Bowen. Mr. Cummings proposed the "Health of the Officers," and Mr. Patchett, the president of the association, responded.

The supply of property at the Tokenhouse-yard Mart during last week was of a limited character, and chiefly consisted of London and suburban brick and mortar investments. In some instances the demand for these properties was brisk, and in a few cases very exceptional prices were obtained. For reversions and life policies there was a good market, over £40,000 being realised for these speculative investments. The aggregate for the week amounted to £91,825, as compared with £65,142 for the same week in last year. During the month of February, although the supply has not been heavy, property has sold well, the total amount of the sales being £412,308, as compared with £318,909 for the corresponding month in 1897.

## WATER SUPPLY AND SANITARY MATTERS.

LIVERPOOL.—The conversion of Cowny Valley into a lake for the supply of water to Liverpool formed part of the original Vyrnwy scheme, and progress is now being made with this undertaking. With a view to the creation of this second watershed, a tunnel to Lake Vyrnwy is in course of construction, and the completion of this work will assure Liverpool of a generous water supply for many years to come. It is proposed to extend the accommodation of the Vyrnwy Hotel, which is thronged with visitors during the short summer season.

MOFFAT, N.B.—A special meeting of Moffat Burgh Commissioners was held last week to decide upon one of three systems of sewage purification as reported on by Mr. T. O. Niven, C.E., Glasgow. It was resolved to adopt the system known as Mr. Dibdin's, or the Sutton system, by which the sewage receives biological treatment, being purified by bacteria before being discharged into the river. At Moffat, owing to the substratum of land being porous, the tanks will require to be built of brick instead of being cut out of clay where this is available. It is proposed to provide an installation capable of dealing with 200,000 gallons in twenty-four hours, which will necessitate an area of about 670 square yards for tank and filter accommodation. The total estimated cost of the system is £2,350.

## CHIPS.

An organ built by Messrs. Hele and Co., of London and Plymouth, was opened on the 3rd inst., at the Presbyterian Church, Augustine-parade, Bristol.

Through the courtesy of the architects (Messrs. Gibson and Russell, London), the members of the Leeds and Yorkshire Architectural Society and of the York Architectural Society were recently enabled to pay a joint visit of inspection to the county buildings which have been erected for the West Riding County Council at Wakefield. The party were met on their arrival by Mr. A. E. Marsh (clerk of works), who escorted them over the premises.

The Mersey Docks and Harbour Board have unanimously agreed, on the recommendation of the committee of works, to proceed with the extension of the Wallasey landing-stage at an estimated cost of £24,500. The stage will be extended 250ft. at its northern end.

The Anglesey County Council have decided almost unanimously to sanction a scheme for the construction of a light railway—probably in a form of an electric tramway—between Llanfair P.G. and Beaumaris.

Experiments have been made, the *Peterborough Advertiser* says, with brick-earth on the works of the New Peterborough Brick Company with the object of ascertaining the possibility of making white facing bricks of fine quality. The experiments have proved successful, and a first-class smooth-faced white brick is obtained from it. There is a likelihood of this description of brick becoming one of the most expensive turned out at the local yards, and there is every probability of a large demand being made for it.

The rebuilding of the barracks at Winchester on the new plan and site will be commenced soon after the tenders have been opened at the commencement of next month. The foundations will swallow up a lot of Wren's buildings, which are to be converted with concrete.

The Southampton board of guardians at their last meeting appointed Mr. Gutteridge, of that town, architect for the proposed new workhouse buildings on the Shirley Warren site.

A new organ erected in the Congregational chapel, Heywood-road, Castleton, Lancs, was opened last (Thursday) night. The organ, which is composed of three manuals, with 26 stops, and necessary couplers, has been built by Messrs. Driver and Co., of Burnley.

A three-light window in the south transept of Claydon parish church, near Ipswich, has just been filled with stained glass as a memorial. Mr. A. J. Moore, of Southampton-row, Russell-square, W.C., was the artist, and the subjects are the Annunciation, the Nativity, and the Presentation in the Temple.

A local Government inquiry was held at Newport, Mon., on Friday, into the application by the borough council to borrow £5,000 for the purpose of laying down wood-paving in High-street and Commercial-street. There was no opposition to the loan.

On Thursday in last week at the Camden Hotel, Pembury, Mr. G. W. Willcocks, M.Inst.C.E., held an inquiry on behalf of the Local Government Board, into an application by the Tonbridge Rural Sanitary Authority for a provisional order to compulsorily acquire lands required for the purposes of a sewerage scheme for the parish of Pembury.







"PHOTO-TINT", by James Akerman & Queen Square London W

ATION FOR BOYS, BUSHEY.

DESIGN.





# ROYAL MASONIC INSTITUTION FOR BOYS, BUSHEY.

## SELECTED DESIGN.

MESS<sup>RS</sup> GORDON, LOWTHER & GUNTON, ARCHITECTS

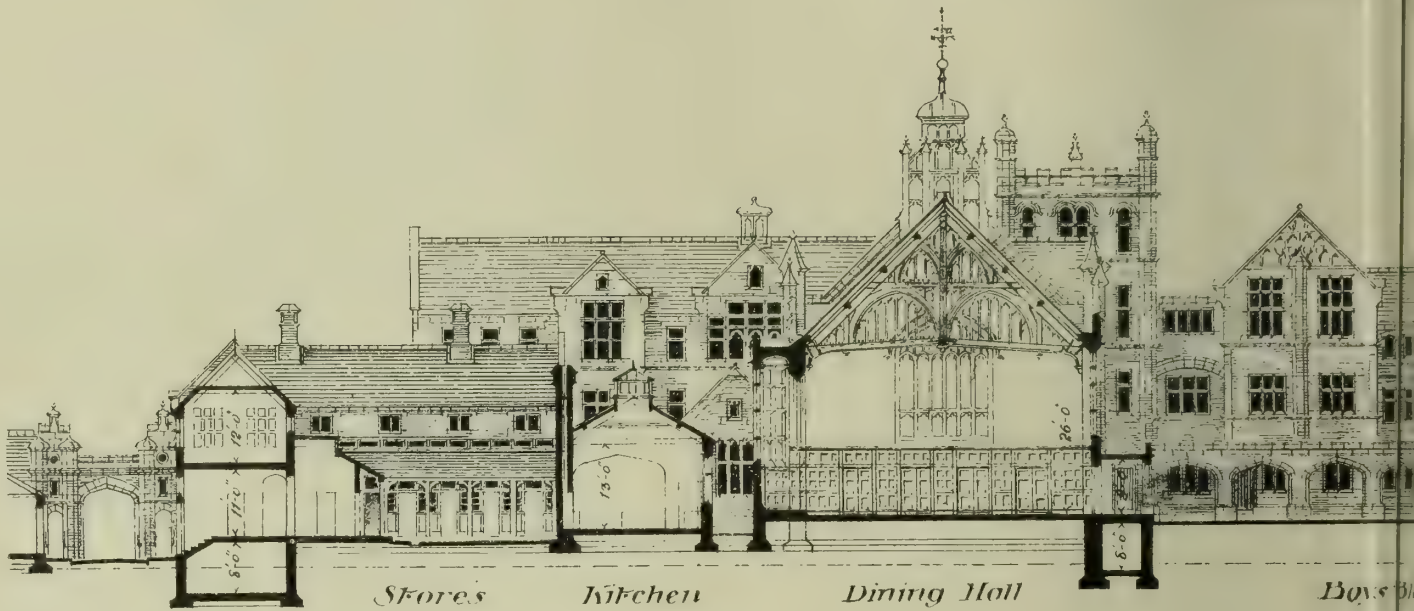
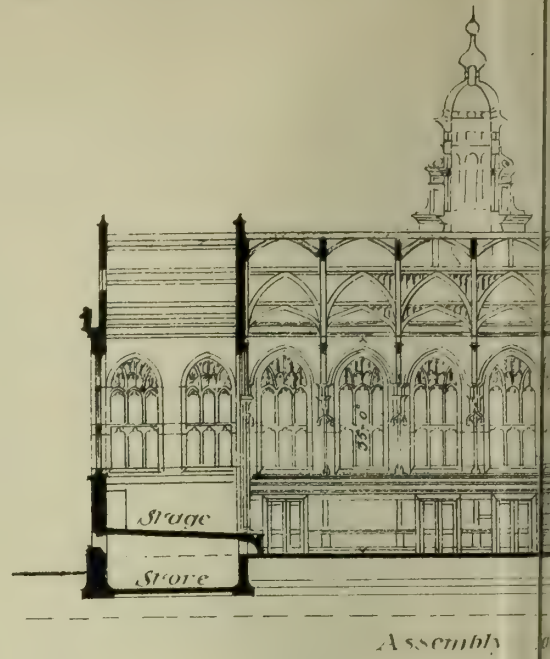

### Section and Elevation

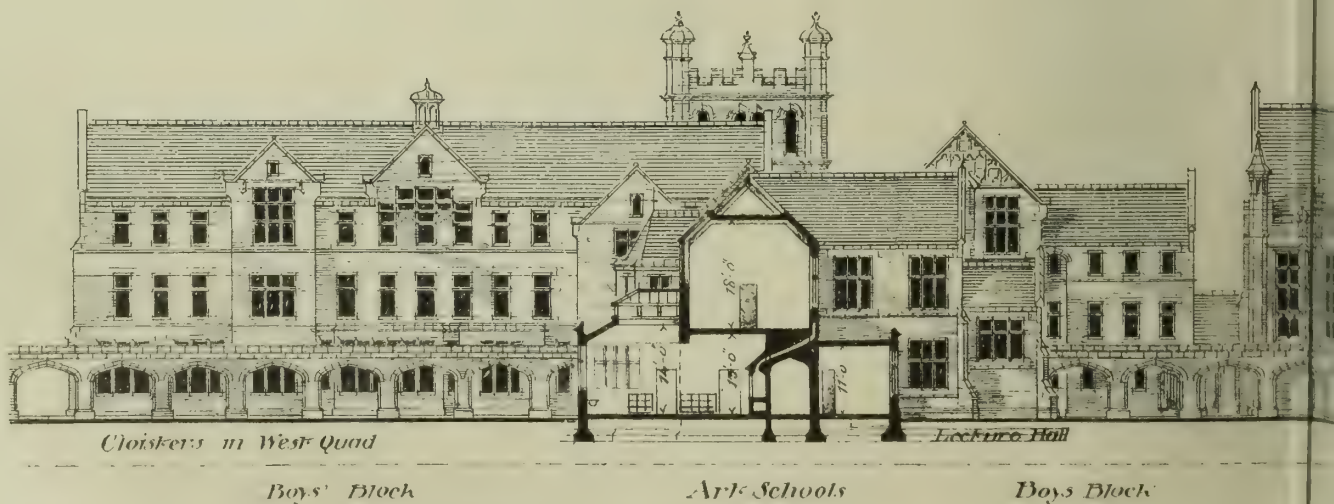

### Section and Elevation



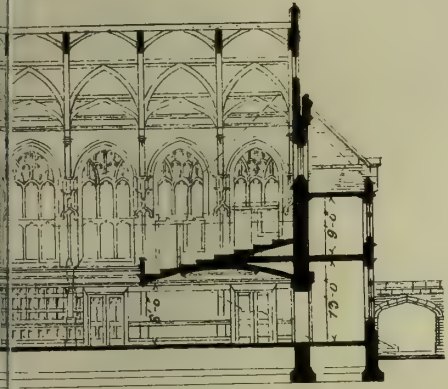

111

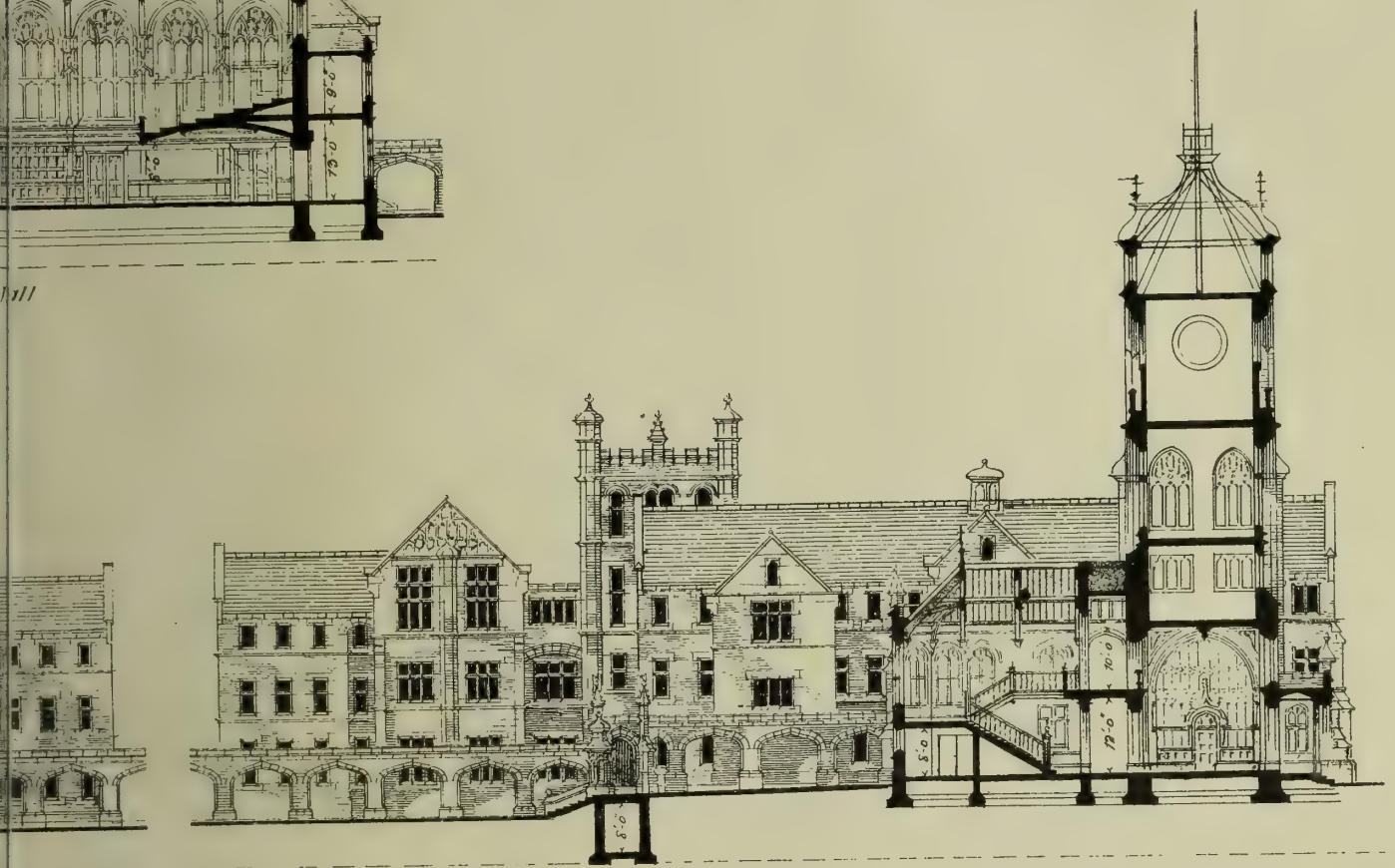

*Block*      *Boys' Block*      *Boys' Block*      *Principal Stairs & Entrance Hall.*

Section on line A.B.

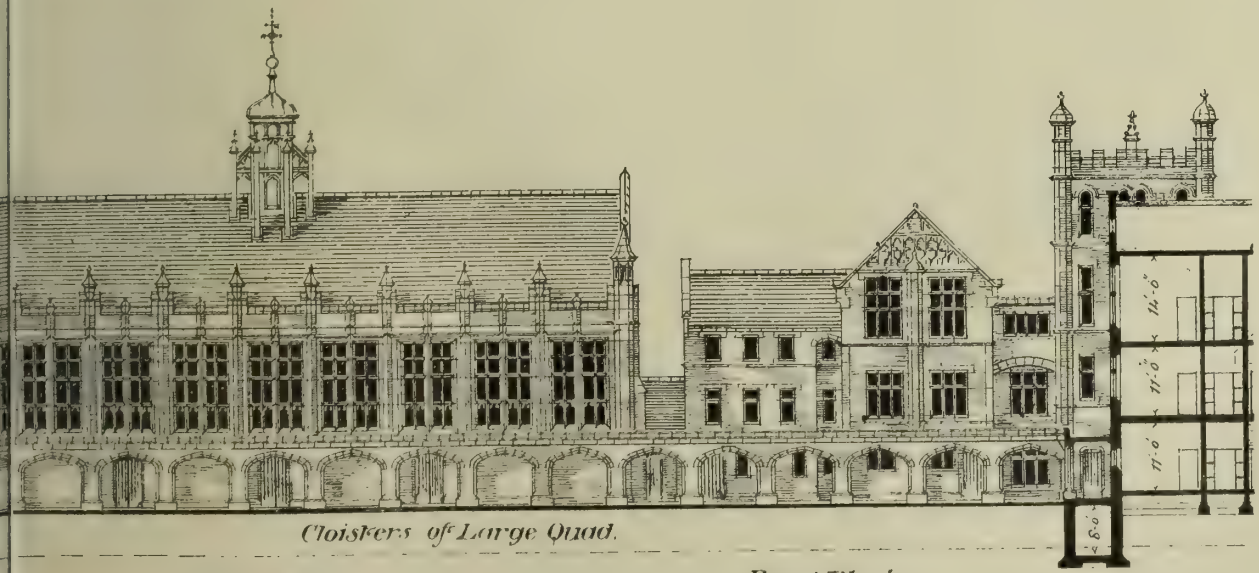

*Cloisters of Large Quad.*      *Dining Hall*      *Boys' Block*

Section on line C.D.





NATIONAL SILVER-MEDAL DRAWINGS BY JOHN J. BROWNSWORD





STUDIES OF ANIMAL LIFE TREATED FOR DESIGN

"PHOTO-TINT" by James Akerman & Queen Square London W.C.





ROYAL MASONIC INSTITUTION FOR BOYS, BUSHEY.

SELECTED DESIGN.

MESS<sup>RS</sup> GORDON, LOWTHER & GUNTON, ARCHITECTS



Assembly Hall

Head Master's House

Boys' Block

Boys' Block

Board Room

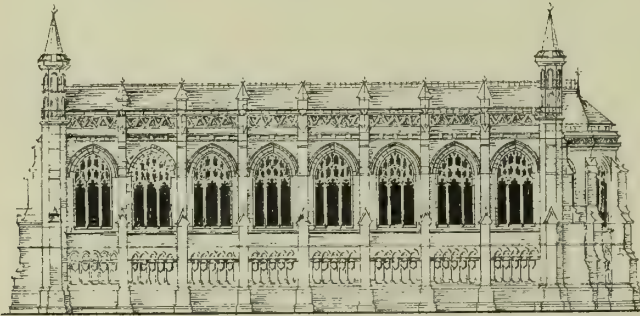

S. Elevation.

Chapel.



Workshops.

Drill Hall.

Boys' Block.

Class Rooms.  
Covered Playground.





Museum etc. Entrance Tower. Masters & Matrons' Rooms  
Administration Block

Boys Block

Boys Block

Front Elevation.



Assembly Hall.

Music School.

Class Rooms.

W. Elevation

West Side Elevation.



## LEGAL INTELLIGENCE.

**RIOTOUS ASSESSMENT OF RIGHTS OF WAYS.**—In the Queen's Bench Division of the High Court, on Saturday, before the Lord Chief Justice, Mr. Justice Grantham, Mr. Justice Wright, Mr. Justice Bigam, and Mr. Justice Darling, sitting as a Court for the Consideration of Crown Cases Reserved, an appeal was heard against a conviction of Henry Clemens and 19 others for having, on August 31 last, maliciously damaged a wooden structure, the property of the Headland Hotel Company, at Newquay, Cornwall. The hotel company had obtained a lease of land from the owner at Newquay, and begun excavations for the erection of a hotel, from plans by Mr. Silvanus Trevail, F.R.I.B.A., of Truro, and had put up a wooden building as an office. The defendants and other persons, claiming rights of net-drying and resort for recreation on the land, pulled down this building, and threw the materials of it into the sea. They were brought up for trial at the Bodmin Quarter Sessions, when their defence was that the acts alleged against them had been done in good faith, in assertion of rights which they believed to be possessed by the inhabitants of Newquay. The jury returned a general verdict of guilty, and also found that the defendants acted on the *bona-fide* belief that they were entitled to remove the building, and that they did more damage than was necessary. A fine of 40s. was imposed on each defendant, and a case was reserved for the consideration of the Court. Their Lordships upheld the conviction.

**COMMISSION ON A BUILDING LEASE**—**MARTIN AND PURCHASE V. RAFFERTY.**—This, an action heard by Mr. Justice Wright on Saturday, was brought by Mr. George Dennis Martin and Mr. Edward Keynes Purchase, architects and surveyors, formerly carrying on business in partnership, against Mr. William John Rafferty, to recover £700 under an agreement dated March 11, 1895. Defendant denied liability. In March, 1895, the defendant was the owner in fee simple of some land at Bayswater which he was desirous of letting on a building lease at a ground rent, or selling. By an agreement dated March 11, the defendant agreed to pay the plaintiff a certain commission if he let the land on a building lease at a ground rent. There was also a clause in the agreement to the effect that if the defendant should let the land to a tenant not introduced by the plaintiffs, at a ground rent not exceeding £600 a year, he would pay them £350 in full settlement, and that if the ground rent exceeded that sum, the plaintiffs should receive one-half of the excess, calculated at 14 years' purchase. Plaintiffs' case was that they used their best efforts to let the land, and that while they were in negotiations with certain persons who were likely to take the site on a building lease, the defendant let the land to a Mr. Schofield, who was not introduced by them, at a ground rent of £675 per annum. Therefore they said they were entitled to recover £700. Defendant denied that the plaintiffs used their best endeavours to let the land, and contended that, under the agreement, he was relieved from liability, inasmuch as he had to abandon the letting of the land and to commence building thereon. Mr. Justice Wright said, in his opinion, the defendant never did abandon the intention of letting the site, though he took steps to begin building operations in order to save the County Council license. There would be judgment for the plaintiff for the amount claimed, with costs.

**DISPUTE AS TO BRICKS.**—At the West Bromwich County-court on Friday, before Judge Griffith, an action was brought by Messrs. P. and S. Wood, brick manufacturers, Greets Green, against Messrs. Monk and Newell, contractors, of Heckmondwike, near Leeds, to recover £16 8s. for the supply of bricks. The plaintiffs' case was that in April, 1896, the defendants obtained a contract for the erection of works at Heckmondwike belonging to the London and North-Western Railway Company. Plaintiffs' tender for bricks was accepted, and 100,000 were forwarded, but 20,000 were rejected. The defence was that the bricks rejected were of an inferior quality to those the plaintiffs quoted for. A counter-claim for £20 was put in by the defendants, on the ground that the bricks were not equal to the standard stipulated in the contract. The Judge gave a verdict for the plaintiffs on the claim, and also in respect of the counter-claim, but granted the defendants leave to appeal.

**CURIOUS BREACH OF CONTRACT CASE.**—**HASLETT V. THE NORTH SUNDERLAND RAILWAY COMPANY.**—In this action, heard on Wednesday in the Queen's Bench Division by Mr. Justice Mathew, the plaintiff, Mr. Alfred Haslett, a contractor, claimed from the defendant company a sum of £2,611 5s. 6d. for work and labour done and materials supplied, and also damages for breach of contract. The claim arose out of the construction of a railway for the defendant company. On May 4, 1896, the plaintiff entered into a contract with the defendants to construct a railway for them from Sunderland to Seahouses, a distance of four miles, for £24,500. The contract was not actually executed, but it was adopted by the board of directors of the defendant company, and the plaintiff was authorised to com-

mence the work. On May 14 the first sod was cut, and the plaintiff began erecting machinery and bringing materials for the purpose. It was a term of the contract that the plaintiff should on its execution deposit with the defendants a sum of £1,000 as security for its due performance, and this amount was to be repaid by instalments as the line progressed. It was also a term of the contract that the defendants were to pay the plaintiff £500 seven days after the commencement of the work, and another £500 14 days after that event. It so happened that the plaintiff, contrary to his expectations, had been unable to raise the £1,000 to deposit with the defendants, and so the contract was never executed. The work, however, was carried on by the plaintiff right up to September, 1896, when the defendants gave him notice to leave off, and terminated the contract on the ground that, as he had not paid the sum of £1,000, they were entitled to withdraw from the agreement. The defendants had not paid either of the two sums of £500 agreed on, nor anything except £200 on account, for work and labour done, which the plaintiff estimated at over £1,500. The plaintiff's case was that, though the contract had not been executed, since the directors had adopted it and had authorised the plaintiff to begin the work, the defendant company must be held to be bound by the contract. For the defendants it was said that they were quite willing to pay on a *quantum meruit* for work actually done by the plaintiff. The defendants, however, were not liable for breach of contract. The authority of the directors to commence the work was given subject to the payment of the deposit, and that was a condition precedent to the contract. Mr. Justice Mathew held that the condition that the plaintiff should pay £1,000 deposit was a condition precedent, and was vital to the contract, and therefore the plaintiff could not recover damages for breach of it. The plaintiff would be entitled to payment for what work he had done. Terms being agreed on, judgment was entered for the plaintiff for £1,500, less £200 already paid to him, and £200 brought by the defendants into court.

**CONTRACT NOT UNDER SEAL: A LEGAL INJUSTICE.**—At the Grantham County Court last month, before Judge Wightman Wood, an action was brought by Messrs. Foley Bros., contractors, Bourne, against the Bourne Rural District Council, to recover £46 for work done and materials supplied in connection with a contract for the sinking of an artesian well. The case was heard by a jury, who found in favour of the plaintiffs for £37 10s. A technical point was raised for the defence, that as the contract was not under seal the plaintiffs had no claim, and on this point his Honour reserved judgment. On Tuesday Judge Wood said he had looked up authorities on the subject, and the result was that, as the contract was not under seal, it did not bind the council, and plaintiffs could not recover the value of the work, notwithstanding the verdict of the jury. He added that he knew of no instance in which there was so strong a conflict between the law of the land and the common-sense of those who live under it. In the present case the defence must prevail, and his Honour gave judgment of non-suit, but without costs.

## CHIPS.

The promoters of a pier company at Colwyn Bay seek to construct a pier, jetty, and landing-place, 1,000 yards in length, close to the L. and N.W. Railway subway. The estimated cost of the works is set down at £40,000.

Colonel Hepper, Local Government Board inspector, sat at Skipton on Tuesday to inquire into an application by the urban district council to borrow £1,200 for their Broughton-road sewerage scheme, and with respect to a further application to borrow £400 for a new steam fire-engine and appliances. There was no opposition.

In the competition recently decided for the best scheme of warming, ventilation, &c., for the new Infectious Diseases Hospital, Leeds, the scheme and tender of Messrs. Dargue, Griffiths, and Co., Ltd., of 72, Grey-street, Newcastle, was formally adopted by the corporation of the former city.

The Wesleyan General Chapel Committee have just sanctioned proposals for the erection of 13 new chapels in various parts of the country, at an estimated expenditure of £38,980. This brings up the total to 26 within the past two months. One of the proposed new chapels is at Twickenham. Another new chapel, to cost £9,153, is to be built at Weston-super-Mare. It will seat 1,000 persons. A sum of £5,364 is to be expended on alterations.

It was reported to the Manchester Corporation at the last meeting that the last arbitration under the Thirlmere water supply scheme had just been finished, and the award had been received. The late Mr. Watt was the contractor who did the work, and his executors went to arbitration, claiming £95,000 for extra work. The umpire sat a long time, and the result was that he awarded the executors of Mr. Watt £16,709.

## Our Office Table.

In the Parliamentary Estimates for the ensuing year the total for Public Works and Buildings shows a reduction of £57,279. The chief feature is the disappearance of the Vote for extending Admiralty buildings, from Messrs. Leeming and Leemings designs, a service for which other provision will be sought. In the Estimate for Royal Palaces, which has risen from £34,000 to £58,000, there is included a sum of £3,500 for beginning the installation of electric light at Buckingham Palace, and £15,000 for further restoring the State Rooms and Banqueting House at Kensington Palace. In the Estimate for Royal Parks, &c. (increase £12,850), the maintenance sub-head has grown by £3,530, while the new works include the completion (£6,600) of the new wing to the Temperate House at Kew Gardens, and further improvements (£1,000) in lighting footpaths in St. James's, Green, and Hyde Parks. The Public Buildings Vote includes an item of £25,000 for alterations to Hertford House, purchased in 1897-98 at a cost of £80,000 for housing the Wallace Collection recently bequeathed to the nation. The Estimate for Public Works and Buildings, Ireland, contains an item of £2,000 on account of the commencement of the National Gallery extension in Dublin.

ONE of the first subjects with which the newly-elected London County Council will be called upon to deal is a proposal that the Council's sinking fund should be utilised for the purchase of well-secured freehold ground-rents within the Metropolitan area. The matter will come up on a report of the Finance Committee, in which the arguments in favour of and against the proposal are dealt with, and it is stated that there is a diversity of opinion upon the subject. On the whole, the committee think that well-secured ground-rents bought at fair prices would give a good return upon the purchase money, and that the Council would be justified, from a financial point of view, in asking authority to invest, with the consent of the Treasury, its sinking fund in that class of securities. At the same time, they do not think that the necessity has as yet arisen for seeking new investments for the sinking fund, which does not at present suffice to meet the applications from local authorities for loans, and money has to be borrowed yearly by the issue of new stock to make good the balance and meet the Council's own capital expenditure. If the sinking fund should at any time exceed the demand of its use, the question of other investments must be considered; but at present they do not advise the Council to apply to Parliament for power to invest the sinking fund attached to the Council's stocks in the purchase of ground-rents.

A MEETING was held in the Douglas Hotel, Newcastle-on-Tyne, on Friday night, to consider the desirability of instituting a building trades' exchange on somewhat similar lines to those which have been successful in Glasgow and Edinburgh. There was a large attendance of gentlemen connected with various branches of the building trade. Mr. J. G. Walker presided. The Chairman said some time ago a representative meeting of the various trades was held, when it was determined that a deputation should visit Glasgow, and see how matters really stood there. The report given by the deputation was a satisfactory one, it being stated that the exchanges at Glasgow and Edinburgh had been distinct successes. Col. Bennett, of Glasgow, the founder of these exchanges in Great Britain, then gave an address, from which it appeared that the building trade exchange is an American institution. He said that at Glasgow they had proved to a certain extent the possibility of the existence of those exchanges in this country. It was of the greatest importance to have a central office where they could at a certain hour expect to meet those engaged in different branches of the building trade. The exchange could be open from 8 till 5, the hours of meeting being from 11.30 to 1 o'clock. There would be a telephone, telegraph, special service of messengers, ample supply of business and daily papers, while the exchange would also be a place where they could exchange ideas. The public would have more confidence in the tradesmen they employed, and a better feeling would be established between the architects, the surveyors, and the tradesmen in general. Mr. David Cook, secretary of the Glasgow Building Trades Exchange, also addressed the meeting, and

Mr. Laird, also of Glasgow, explained that the exchange had nothing to do, as had been alleged, with keeping up prices. It did, however, say that the contracts should be carried out in a fair and honourable fashion. Mr. John Ferguson moved:—"That this meeting is of opinion that it is desirable that a Building Trades Exchange for the city and council of Newcastle, the borough of Gateshead, and the district generally should be formed, and appoints a committee to promote a limited liability company to carry out this object." Mr. W. Lister Newcombe seconded the resolution, which was carried unanimously. A committee was then appointed.

The annual distribution of prizes in connection with the Edinburgh Technical School for apprentices and young men of the house-painting trade was made on Friday night in the Heriot-Watt College, Edinburgh. Baillie Mackenzie presided. Principal Grant Ogilvie reported that over a hundred students had entered the classes, and the work done had been very good. The scholars had worked successfully and diligently, and their conduct had been entirely satisfactory. The report of the examiners (Messrs. Thomas Kirkpatrick, Leith, and David Bisset and Thomas Hardy, Edinburgh), stated that the exhibition of work for the session reflected great credit on teachers and pupils alike. The chairman, in presenting the prizes to the pupils, impressed upon them the benefit of technical education in preparing them in all matters concerning their trade. The following were the principal prize-winners:—Class medallists: Class A, Alexander Flynn; Class B, Duncan Gollan. First grade for first and second year apprentices: Plain work, George Keppie; lettering, John Heatley; lining and stencilling, George Glass. Third and fourth year apprentices: Plain work, James Russell; lettering, Duncan Gollan; graining, Robert Wishart; lining and stencilling, George Taylor. Fifth and sixth year apprentices: Lettering, Robert Heriot; painted panels, J. R. Cantley. Certificates were also awarded to apprentices for graining, lettering, and painted ornaments.

The Ontario Association of Architects have decided to petition the Ontario Government to grant a sum of money to defray the cost of making scientific tests at the School of Practical Science, Toronto, of the various native woods adapted to building requirements. The series of tests of Canadian building stones made a few years ago, under the direction and at the expense of the association, have proved so valuable that, in many portions of the Dominion they have taken the place of reference tables and practice. The authorities of the Toronto School of Science have also conducted tests of native woods formerly employed by architects in their bricks, concrete, and cement, so that the qualities of these materials are in a measure understood. No adequate tests have yet been made, however, of native building timber. In view of the extent to which wood is employed for supports in buildings it is desirable that the strength and physical characteristics of the various woods employed should be well understood, in order that the requisite factor of safety may be used.

The thirty-third annual report of the trustees of the Peabody Donation Fund for 1897 states that the year's net gain from rents and interest has been £32,320. The total fund on December 31 last was £1,220,446. Of the £85,000 advanced by the Bank of England, the trustees have repaid £53,500, leaving a balance of £31,500 still due. The capital expenditure on land and buildings to the end of the year was £1,250,390. The whole of the repairs for the year, amounting to £12,232, which include extensive structural and drainage alterations at Islington, Shadwell, and Stamford-street, have been charged to income as formerly. At the end of the year the trustees had provided for the artisan and labouring poor of London 11,367 rooms, besides bath-rooms, laundries, and lavatories. These rooms comprised 5,121 separate dwellings—viz., 86 of four rooms, 1,781 of three rooms, 2,426 of two rooms, and 828 of one room. The death-rate, including the deaths of 69 inhabitants of the buildings removed to hospitals, was 15·4 per 1,000, which is 2·8 per 1,000 below the average of London.

The old-established and wealthy Guardian Fire and Life Assurance Company, which has hitherto confined its business to fire and life assurance, is now issuing accident policies of all kinds, and is prepared to consider proposals for the insurance of the entire liability of employers, under the Employers' Liability Act and the new Work-

men's Compensation Act, without any limitation. The "Guardian," with its large capital and resources, offers unequalled security for such protection. It has a paid-up capital of £1,000,000, and a subscribed capital of £2,000,000, and the latter with the fire funds £526,850, amounting in total to £2,526,850, is the security for the policy-holders of the company generally, including accident policy-holders. The anxiety of any of the life policy-holders, who may, perhaps, imagine that the life funds are liable for fire and accident risks, may be at once relieved. The life funds of the "Guardian," in common with those of every life company, amounting to £2,818,721, are secured to them by Act of Parliament, and are, therefore, liable only for the life assurance and annuity contracts of the company.

The Prudential Assurance Company, in its forty-ninth annual report, states that the number of policies issued during the year was 65,893, assuring the sum of £6,698,755, and producing a new annual premium income of £365,996. The premiums received during the year were £2,774,264, being an increase of £231,002 over the year 1896. The claims of the year amounted to £707,643. The number of deaths was 5,038, and 656 endowment assurances matured. The number of policies in force at the end of the year were 497,327. In the Industrial Branch, the premiums received during the year were £4,793,591, being an increase of £214,798. The claims of the year amounted to £1,823,338. The number of deaths was 192,359, and 1,876 endowment assurances matured. The number of free policies granted during the year to those policy-holders of five years' standing, who desired to discontinue their payments, was 60,848, the number in force being 549,889. The number of free policies which became claims during the year was 10,716. The total number of policies in force at the end of the year was 12,546,132; their average duration exceeds eight and a quarter years. The assets of the company, in both branches, as shown in the balance-sheet, are £30,438,337, being an increase of £3,379,226 over those of 1896.

OWING to increased business, Messrs. T. and R. Boote, Ltd., of the Patent Tile Works, Burslem, are removing their London office from Walsham Buildings to more convenient premises at Birkbeck Bank Chambers, Southampton Buildings, Holborn, E.C. The change will take place on March 25, and will no doubt be duly appreciated by their customers, whose wishes will, as heretofore, be attended to by Mr. Thomas Foster, the courteous agent of the firm. Messrs. Boote have recently completed some important contracts for tiling, amongst which are the Blackwall Tunnel, Rangoon and Pretoria Government Offices, and almost the whole of the interior of the Birkbeck Bank Buildings, in which their office will in future be situated, and which will therefore be a permanent specimen of their work.

The fabric of Christ Church, Mold Green, near Huddersfield, is about to be completed by the addition of a chancel and vestries, from plans by Mr. G. F. Bodley, A.R.A.

A dispute as to the ownership of Bridgewater-square, City, was decided on Tuesday by a special jury in the Queen's Bench Division. The plaintiffs, Trustees of Cripplegate Without Boys' Charity School, claimed to be owners of the square, which was formerly the Courtyard of Bridgewater House, the seat of the Earls of Bridgewater, by virtue of a twelve years' undisputed possession. The defendant, Mr. George S. Tranter, who is a member of the Common Council, a resident in the square, and the owner of six houses, contested the claim, urging that the plaintiffs had only been permitted to use the square as a drill-ground through the kindness of the neighbours. A verdict was returned for the plaintiffs.

The Lord Mayor of London and Sheriffs will visit the Northampton Institute, in Clerkenwell, on Friday in next week, the 18th inst., for the purpose of formally declaring it open. The buildings and equipment have up to the present cost over £80,000. In addition, the land, generously given by the late Marquis of Northampton, is estimated to be worth not less than £25,000. We illustrated the buildings, which have been erected from designs by Mr. E. W. Mountford, F.R.I.B.A., selected in competition, in our issue of April 11, 1893. The style is Free Renaissance, the facing materials being red Ipswich bricks with dressings of Monk's Park stone. Mr. Walter Wallis, of Ramsden-road, Balham, was the builder, and Mr. Isaac Gard the clerk of works.

## MEETINGS FOR THE ENSUING WEEK.

- MONDAY.—Society of Arts. "The Thermo-Chemistry of the Bessemer Process," Cantor Lecture No. 1, by Prof. W. N. Hartley, F.R.S. 8 p.m.  
Carpenters' Hall Lectures. "Architecture versus Building," by Professor Banister Fletcher, F.R.I.B.A. 8 p.m.  
Bristol Society of Architects. "Architectural Photography," by G. C. Lawrence. 8 p.m.
- TUESDAY.—Society of Arts. "The West Indies and Sugar Bounties," by Nevile Lubbock. 4.30 p.m.  
Institution of Civil Engineers. "Calcium Carbide and Acetylene," by Henry Fowler. 8 p.m.
- WEDNESDAY.—Society of Arts. "The Recent History of Paper - Making," by Clayton Beadle. 8 p.m.  
Edinburgh Architectural Society. "Ecclesiastical Decoration," by T. Ker-shaw Bonar. 8 p.m.
- THURSDAY.—Civil and Mechanical Engineers' Society. "The Theory and Practice of Co-operation as Applied to Industrial Purposes," by W. N. Twelvetrees, Victoria Hotel, Northumberland-avenue, S.W. 7 p.m.

## CHIPS.

The parish church of Dovercourt, near Harwich, has just been reopened, after restoration under the direction of Messrs. J. E. K. and J. P. Cutts, of London.

The clock purchased by the inhabitants of Kilham, near Driffeld, to commemorate the Diamond Jubilee, now being erected by Messrs. Potts, of Leeds, will be started at noon on Sunday next, March 13.

The new city hospital, Ham Green, Bristol, is being warmed and ventilated throughout by means of Shorland's patent double-fronted Manchester stoves, with ornamental tiled sides and with descending smoke-flues, the same being supplied by Messrs. E. H. Shorland and Brother, of Manchester.

A local syndicate has been formed to promote the construction of a light railway to connect the Great Western system at Brent Knoll with the town of Burnham. Plans have been prepared by Mr. W. H. Aitchison, C.E., and Mr. Chas. S. Leech, of Burnham, joint engineers for the scheme, which provides for a terminus station near the cemetery at Burnham, at a point dividing the business portion of the town from the rapidly-extending residential part. It is proposed that the ordinary gauge should be adopted.

At Monday's meeting of the Morley Town Council five candidates for appointment as borough surveyor and engineer, at a salary of £200 per year, appeared before the council, and it was decided to appoint Mr. W. E. Putman, of the City Engineer's Office, Leeds.

At a public meeting held at Paisley on Monday, under the presidency of Sir M. B. Shaw Stewart, Lord Lieutenant of Renfrewshire, it was decided to take steps for the restoration of Paisley Abbey, in accordance with plans prepared by Dr. E. Rowand Anderson, of Edinburgh. A large and representative committee was elected. It was agreed that the restoration of the abbey should be accompanied by an improvement in the surroundings of the abbey, and that it be remitted to the same committee to consider how best this could be done, and the probable cost of acquiring and laying out neighbouring properties.

About fifty applications have been received for the vacant post of burgh surveyor and sanitary inspector of Peterhead. These have been reduced to a short list of five, consisting of Messrs. Fleming, Dundee; Shand, County Engineer's Office, Aberdeen; Chisholm, Burgh Surveyor, Buckie; Black, Edinburgh; and Budge, Leith.

A deputation from the Glasgow Corporation, consisting of Baillie J. M. Johnson, Baillie R. Anderson, Mr. S. B. Macdonald, M.Inst.C.E., and Mr. T. S. Melvin, manager of the Glasgow sewage works, visited the Manchester Corporation sewage works at Davyhulme on Monday.

Alderman Baker, Alderman Barratt, Councillor Stemberge, and Councillor Fletcher, representing the Improvement Committee of the Birmingham City Council, with Alderman Cook, and Councillors Martineau and Lancaster, representing the Health Committee of the same body, went on Wednesday as a deputation from Birmingham to Liverpool to inspect the provision made by the Liverpool Corporation for the housing of the working classes, and to inquire into the working of the dual system of house-building adopted in that city. The deputation were accompanied by Mr. Adie, the retiring manager of the improvement scheme, and Mr. J. Tart, his successor, and by Mr. H. Price, the city surveyor. They were received at Liverpool by the Lord Mayor and the town clerk, and other members of the corporation, and after their round of inspection were entertained at dinner by the Lord Mayor.

**Trade News.**

**WAGES MOVEMENTS.**

**BRISTOL.**—At a combined meeting of the Carpenters' and Joiners' Societies, held at the Shepherds' Hall, Old Market-street, important changes have been agreed upon in connection with the amended rules regulating their work in Bristol. Notices of these proposed changes, to take effect on July 1st next, have been given to the Master Builders' Association and other employers in the city, with a hope that they would make the concessions asked for on the date named. The operatives ask for 8½d. an hour instead of the present wages of 8d. an hour. With reference to working hours, they ask to reduce the time generally from 48 to 47 hours per week during the months of November and February, and a similar reduction in hours in builders' yards in the months of December and January. Other alterations are asked for with regard to country work and overtime. Other branches of the building trade have sent in similar notices. The monthly meeting of the Master Builders' Association of Bristol is to be held shortly, when the matter will come under consideration.

**LINCOLN.**—The master builders have acceded to the demand of the plasterers for an advance of 1d. per hour in the rate of wages. The new rate, 9d. per hour, has come into force.

**SCARBOROUGH.**—The Scarborough stonemasons have been conceded an increase of ½d. per hour, making 8½d. Commencing on April 1st, work will be begun at 6.30 and extend over nine hours, and in the winter months the men will start at seven and cease at five o'clock. The men asked for 9d. an hour.

**BIRMINGHAM BUILDING WAGES.**—In accordance with the agreements existing between the various sections of the building trade and the Birmingham Master Builders' Association to the effect that six months' notice shall be given on either side for the alteration of rules, the scale of pay, &c., the representatives of the carpenters, plasterers, masons, plumbers, scaffolders, and labourers gave notice in October last of their intention to claim an increase of wages dating from the 1st of April next. In the case of each of the skilled branches, the increase asked for is at the rate of 1d. per hour, whilst the labourers and scaffolders ask for ½d. per hour. Notices were also given by the men of certain alterations desired by them in the rules. Since October several meetings have been held to discuss the situation on both sides, and, owing to the abnormal briskness of the building trade, the operatives have been encouraged to enforce their demands in their fulness. In view of the fact that the granting of the increases asked for would mean an enormous difference in the profits on existing contracts, the employers considered that the offer of an advance of ½d. per hour, to come into operation in April, 1899, would be fair, whilst, on the other hand, the operatives have decided that if the ½d. is granted for the current year they would accept such a settlement as satisfactory now. The latter proposition has not yet been discussed by the masters.

The death is announced of the distinguished French architect M. Louis Petit-Grand.

The new headquarters of the Volunteer Medical Staff Corps were opened by the Lord Mayor of Leeds on the 8th inst. The new premises, which are situated in St. James-street, consist of a drill-hall, staff offices, orderly offices, clothing stores, and residence for staff-sergeant. The rear portion of the site has been reserved for the erection of a model hospital in the near future. The work in connection with this corps has been carried on by Surgeon-Captain De Burgh-Birch from its formation. The new buildings have been erected from plans prepared by William Bakewell, F.R.I.B.A., of Leeds.

At Killick's-road, Mitcham, Surrey, on Saturday, Feb. 26, the foundation-stone of the new church of St. Mark was laid. The church will comprise nave and aisles, north and south transepts, apse, baptistery, north porch, and a small bell turret, and will have 500 sittings. The architects are Messrs. R. M. Chart and Son, of Union Bank Chambers, Croydon and Mitcham, and the contractors are Messrs. D. Stewart and Sons, of Wallington, the amount of their contract for the first portion (nave and aisles), exclusive of furnishing and heating, being £3,319.

The foundation-stone of the new Church Institute and Parochial Hall connected with St. Paul's Church, Prince's Park, Liverpool, was laid in Miles-street, on Friday, by the Hon. Mrs. McNeill. The new building will be of two stories, and will consist of several classrooms, a large room to contain 400 people, and two other large rooms which can be thrown into one for the purpose of a gymnasium and recreation-room. The total cost will be £3,200. Messrs. Wilink and Thicknesse, of Liverpool, are the architects.

**CHIPS.**

Among the members returned to the London County Council on Thursday in last week, were Mr. Walter Emden, J.P., the President of the Society of Architects, who was re-elected for the Strand Division, and Mr. Howell J. Williams, builder, of Bermondsey, formerly member of the Council for Rotherhithe, and now returned for South Islington.

The town council of Taunton decided on Tuesday to adopt the septic method of treating sewage in use at Exeter, and instructed Messrs. Cameron, Commin, and Martin, of Exeter, the patentees, to prepare plans and estimates.

At Hayward's Heath, on Tuesday, Herbert Chapman, described as a London journalist, was committed for trial on a charge of obtaining credit for £69 by false statements. It was alleged that he took a house at a rental of £128 a year, but had paid no rent. The alleged false statements were that he edited the *Builders' Journal* and the *Architectural Review*, and that his wife was related to the Duke of Richmond. Evidence showed that the accused was a canvasser, and that he earned £80 a year.

The Local Government Board has given notice that Col. A. G. Durnford, R.E., one of the Board's inspectors, will hold a local inquiry at the Guildhall, York, to-day (Friday), in reference to the application of the city council for sanction to the borrowing of £23,000 for sewerage purposes.

Owing to a desire on the part of several important exhibitors for more time in which to prepare their exhibits, it has been found necessary to delay the opening of the Building Trades Exhibition at St. James's Hall, Manchester, to June 20, 1898.

A disused building, intended for infectious cases and standing in the grounds of the Melksham Union Workhouse, Wilts, has recently been transformed, at a cost of £1,260, into an up-to-date infirmary for 30 patients, upon plans prepared by Mr. Walter W. Snailum, P.A.S.I., architect, Trowbridge. Mr. E. Linzey, of Trowbridge, was the contractor.



**BILLS OF QUANTITIES, PLANS, &c.**

Lithographed in best style and with great expedition by  
**PARTRIDGE & COOPER,**  
 ARCHITECTS' AND SURVEYORS' LITHOGRAPHERS,  
 191 & 192, Fleet St., and 1 & 2, Chancery Lane,  
 London, E.C.  
*Special Prices quoted for Large Jobs.*  
 LIBERAL DISCOUNTS ACCORDING TO ARRANGEMENT.

**W. H. LASCELLES and Co.,**  
 121, Bunhill Row, London, E.C.  
 TELEPHONE No. 270.

**HIGH-CLASS JOINERY.**  
**LASCELLES' CONCRETE.**  
**Conservatories & Greenhouses.**  
**WOODEN BUILDINGS.**  
**BANK, OFFICE, & SHOP FITTINGS.**  
**CHURCH BENCHES & PULPITS.**

ESTIMATES GIVEN ON APPLICATION.

**IS THE ELECTRIC LIGHT REALLY  
 DEARER THAN GAS?**

A large number of replies to the above query from actual users will be sent post free on application to the

**COUNTRY HOUSE SPECIALISTS,**  
**Messrs. DRAKE & GORHAM,**  
 66, VICTORIA STREET, WESTMINSTER, LONDON, S.W.

**HAM HILL STONE.**  
**DOULTING STONE.**  
**THE HAM HILL & DOULTING  
 STONE CO.**

Incorporating THE HAM HILL STONE CO. and C. TRASK and SONS (THE DOULTING STONE CO.)

Chief Office: NORTON, STOKE-UNDER-HAM, SOMERSET.  
 London Agent: Mr. E. A. WILLIAMS, 16, CRAVEN STREET, STRAND.

**LATEST PRICES.**

IRON, &c.		
	Per ton.	Per ton.
Rolled-Iron Joists, Belgian.....	£6 0 0	to £6 10 0
Rolled-Steel Joists, English.....	6 10 0	" 7 10 0
Wrought-Iron Girder Plates.....	5 15 0	" 6 10 0
Bar Iron, good Staffs.....	7 0 0	" 8 0 0
Do., Lowmoor, Flat, Round, or Square.....	17 0 0	" 17 0 0
Do., Welsh.....	5 15 0	" 5 17 6
Boiler Plates, Iron—		
South Staffs.....	7 17 6	" 8 5 0
Best Snedshill.....	10 0 0	" 10 10 0
Angles 10s., Tees 20s. per ton extra.		
Builders' Hoop Iron, for bonding, &c., £6 15s. 0d. per ton.		
Builders' Hoop Iron, galvanised, £15 10s. 0d. per ton.		
Galvanised Corrugated Sheet Iron—		
No. 18 to 20.	No. 22 to 24.	
6ft. to 8ft. long, inclusive	Per ton.	Per ton.
gauge.....	£10 15 0	to £11 0 0
Best ditto.....	11 5 0	" 11 10 0
Per ton.		
Cast-Iron Columns.....	£6 0 0	to £8 10 0
Cast-Iron Stanchions.....	6 0 0	" 8 10 0
Cast-Iron Sash Weights.....	—	" 4 2 6
Cast-Iron Socket Pipes—		
3in. diameter.....	5 10 0	" 5 15 0
4in. to 6in.....	5 5 0	" 5 10 0
7in. to 24in. (all sizes).....	4 15 0	" 5 0 0
[Coated with composition, 2s. 6d. per ton extra; turned and bored joints, 5s. per ton extra.]		
Pig Iron.....		Per ton.
Cold Blast, Lilleshall.....		105s. to 110s.
Hot Blast, ditto.....		57s. 6d. to 62s. 6d.
Wrought-Iron Tubes—Discount off Standard Lists f.o.b.		
Gas-Tubes.....	75p.c.	Fittings 77½p.c.
Water-Tubes.....	70	" 72½
Steam-Tubes.....	62½	" 65
Galvanised Gas-Tubes.....	60	" 62½
Galvanised Water-Tubes.....	55	" 57½
Galvanised Steam-Tubes.....	45	" 47½
10cwt. casks. 5cwt. casks.		
Sheet Zinc, for roofing and working up.....	£22 10 0	to £23 10 0
Sheet Lead, 3lb. per sq. ft. super.....	14 10 0	" 15 10 0
Pig Lead, in lwt. pigs.....	13 12 6	" 14 12 6
Lead Shot, in 25lb. bags.....	17 10 0	" 18 10 0
Copper Sheets, sheathing and rods.....	58 10 0	" 59 10 0
Copper, British Cake and Ingot.....	51 15 0	" 52 15 0
Tin, Straits.....	65 13 0	" 66 18 0
Do., English Ingots.....	69 0 0	" 70 0 0
Spelter, Silesian.....	17 7 6	" 18 7 6
Per ton.		Per ton.
Cut Clasp Nails, 3in. to 6in.....	£8 15 0	" £9 15 0
Cut Floor Brads.....	8 10 0	" 9 10 0
Wire Nails (Points de Paris)—		
0 to 7 8 9 10 11 12 13 14 15 B.W.G.		
8/6 9/0 9/6 10/3 11/0 12/0 13/0 14/9 16/9		per cwt.

**TIMBER.**

Teak, Burmah.....per load	£13 0 0	to £15 10 0
" Bangkok.....	10 0 0	" 15 0 0
Quebec pine, pitch.....		
" yellow.....	2 2 6	" 4 2 6
" Oak.....	3 15 0	" 5 0 0
" Birch.....	2 15 0	" 4 10 0
" Elm.....	3 15 0	" 5 0 0
" Ash.....	3 0 0	" 3 10 0
Dantsic and Memel Oak.....	2 10 0	" 3 9 0
Fir.....	1 9 0	" 3 15 0
Wainscot, Riga p. log.....	3 5 0	" 6 10 0
Lath, Dantsic, p.f.....	4 10 0	" 6 10 0
St. Petersburg.....	5 0 0	" 6 10 0
Greenheart.....	8 5 0	" 8 10 0
Box.....	4 0 0	" 15 0 0
Sequoia, U.S.A. ....per cube foot	0 1 8	" 0 1 10
Mahogany, Cuba, per super foot		
1in. thick.....	0 0 5	" 0 0 6½
" Honduras.....	0 0 4½	" 0 0 6½
" Mexican.....	0 0 4	" 0 0 5
Cedar, Cuba.....	0 0 4	" 0 0 4½
" Honduras.....	0 0 3	" 0 0 4½
Satinwood.....	0 0 6	" 0 1 2
Walnut, Italian.....	0 0 3	" 0 0 7
Deals, per St. Petersburg Standard, 120—12ft. by 1½in. by 1½in. :—		
Quebec, Pine, 1st.....	£19 5 0	to £25 5 0
" 2nd.....	13 15 0	" 16 5 0
" 3rd.....	6 5 0	" 10 15 0
Canada Spruce, 1st.....	9 5 0	" 11 5 0
" 2nd and 3rd.....	8 0 0	" 9 0 0
New Brunswick.....	6 5 0	" 7 5 0
Riga.....	6 15 0	" 7 15 0
St. Petersburg.....	8 15 0	" 12 15 0
Swedish.....	9 0 0	" 15 10 0
Finland.....	7 10 0	" 8 0 0
White Sea.....	9 0 0	" 15 10 0
Battens, all sorts.....	5 0 0	" 18 0 0
Flooring Boards, per square of 1in. :—		
1st prepared.....	£0 9 0	" £0 16 6
2nd ditto.....	0 7 6	" 0 13 0
Other qualities.....	0 6 0	" 0 7 6
Staves, per standard M:—		
Quebec pipe.....	£35 0 0	" £42 10 0
U.S. ditto.....	230 0 0	" 240 0 0
Memel, cr. pipe.....	200 0 0	" 210 0 0
Memel, track.....	200 0 0	" 210 0 0
OILS.		
Linsed.....per ton.	£16 0 0	to £16 18 0
Rapeseed, English pale.....	24 5 0	" 24 10 0
Do., brown.....	22 15 0	" 23 5 0
Cottonseed, refined.....	13 15 0	" 14 5 0
Olive, Spanish.....	33 0 0	" 38 10 0
Seal, pale.....	24 0 0	" 24 10 0
Cocunut, Cochim.....	27 10 0	" 28 0 0
Do., Ceylon.....	22 0 0	" 22 15 0
Palm, Lagos.....	23 5 0	" 23 10 0
Oleinc.....	18 15 0	" 19 15 0
Lubricating U.S.....per gal.	0 6 3	" 0 7 6
Petroleum, refined.....	0 0 4½	" 0 0 4½
Tar, Stockholm.....per barrel	1 0 0	" 1 5 0
Do., Archangel.....	0 12 6	" 0 15 0
Turpentine, American... per ton	23 0 0	" 23 10 0

LIST OF COMPETITIONS OPEN.

Table listing competitions open, including Carlisle - Silver Gilt Casket, Berwick-on-Tweed - Police-Station, and various architectural and engineering projects with their respective dates and locations.

LIST OF TENDERS OPEN.

BUILDINGS.

Table listing tenders open for various buildings, including Macroom - Drying Chamber, Tuckingmill - Renovation, and numerous school and public works projects across different regions.

# THE BUILDING NEWS

## AND ENGINEERING JOURNAL.

VOL. LXXIV.—No. 2254.

FRIDAY, MARCH 18, 1898.

### INSTITUTE OF PAINTERS IN WATER COLOURS.

A VARIETY of methods and of merit is to be seen in this popular exhibition of water colours. There are not only works which savour too much of the mere picture buyer, and which show the desire to bring down painting to the level of the average public, but others which aim at higher ideals. We can notice only a few of the more meritorious contributions. John Fulleylove, whose early architectural training has made him faithful to his early love, sends several bright and spirited water-colour sketches from the Continent. His "Hotel de Ville, Bruxelles," and other views of that city "The Parthenon from the Propylæa" (42), "The Caryatid Portico of the Erechtheum, Athens" (153), &c., are all truthful and feeling sketches, in which drawing is not sacrificed to effect. Several very beautiful pictures by Frank Walton of the Cornish coast are hung. We may particularly notice here his view of "The Land's End" (2), "Cape Cornwall" (616), his "Black Rock, Widemouth" (360) "Bude Haven" and "Breakwater" (442-617), all careful and pleasing transcripts. In the same gallery we notice "A Sandy Road" (4), the summit of a hill, by Joseph Knight, inimitable and dextrous in manipulation; a broad sunny sketch in Berkshire, by Edward H. Fahey (12). The president, Sir James Linton, has four subjects. "Roses" is a beautiful, but rather coldly-painted, face in Sir James's best style, graceful in drawing and admirable in technique. The bowl of rich pink blossoms which the dark girl holds daintily in her hands, and the rich yellow brocade sleeves of her bodice, the red coral necklace and pearl trimmings, are exquisite, but there is the fault of hardness. His Shakespearian subjects, "Slender and Anne Page" (190), and "Portia Sending the Letters to her Cousin" in the Merchant of Venice (245) are interesting as examples of the president's claims as a subject-painter. His other single figure "Jaqueline," "Quentin Durward" (357) is more successful, the daintily-shaped little silver goblet which the brunette carries, with a plate of fruit on a waiter, the scarlet skirt and green bodice of the girl make a picturesque subject. Very energetic and forcible is the large centre picture, "Waiting for the Fishing Boats," by Hans von Bartels.

The vice-president, E. M. Wimperis, is also strong. His "Hayfield" (21), is a breezy, fresh landscape, and his "Marsh near Bawdsey Ferry" (89), and "Wet Sands" (177), are all excellent in breadth and colour. Mr. Wimperis is a master of broad expanses of moors and marshes, and he throws the charm of passing shadow and sunlight over them, and gives us the suggestion of showery weather and breeze—some of these are studies in Cornwall. R. B. Nisbet, in his "Waiting for the Tide, Stonehaven," is delightfully quiet and broad. It is a still evening effect: the sombre shades of the harbour and craft stand out from the illumined sky and water-reflected light. Mr. Nisbet has instructively felt the deep solemnity and subtle mystery of the afterglow and mists of his Northern clime, and in this and his Perthshire scenes, "Wet Day," "Afterglow," "Moonlight," "Stormy Day on the East Coast" (555), he has abundantly proved his skill and power in this phase of landscape. A bright sketch, "Old Street, Salisbury" (103), by Miss K. Gordon, must be mentioned; but, perhaps, the chief landscape is Bernard Evans' very

fine view "From Gourdon to the Mediterranean" (113), a grand sweep of rocky hills. The stratified rocks and verdure, the vast perspective of receding hills, and the distant sea are painted with power in this landscapist's most forcible manner. His other subject is "Fountains Hall and the Ladies' Garden, Yorkshire," in the East Gallery. Other pictures that have merit are Miss Rose Douglas' "Market Day, Etaples" (25), a delightfully drawn and brilliant view of a busy market-place, executed in a few telling strokes of the brush; St. Geo. Hare's clever study of a girl by the sea, near rocks, holding her scarlet-lined sunshade during a sudden gust—"Breezy" (32); Innes Fripp's "Treasure Trove," drawn with refined technical skill; John I. Richardson's admirably broad view, "On a Perthshire Moor" (41); David Green's "Misty Morning, Polperro," grey and wet; James Tower's clever coast scenery, "Perwick Bay" (53); and works by St. George Hare, "A Breaking Wave" (57); John Muirhead, Ernest Parton, and Miss Christina Allan (104), charming sketch of "Fishing Village" and fresh colour. William W. Collins's "The Deserted Copper Mine," is a colour-study, really a background for a nude figure of a woman at her toilet, well drawn and strong in the colour of the rocky cavern, and its shades of blue-green and reds. Max Ludley is Turner-like in his large, brilliant-toned landscape No. 142: the atmosphere and light are excellent. The delicacy of colour and mist in F. Stuart Richardson's "Cormorant's Crag, Stonehaven" (149), must be noted; and Robt. Hughes' bold forest scene (141) and S. Marjoribanks' "Mist, Wind, and Rain" (168) are other works of merit. Harry Hine has a broad study, "An Old Bridle Way" (162). Count Seckendorff has a brilliant view of "Scala di Spagna, Rome" (155).

In the Central Gallery, one of the best subjects—merely a sketch study on grey paper—is George Weatherbee's "A Lonely Shore" (179), a mother and child crossing a bleak shore of sandy hillocks. Simple in drawing and arrangement, the artist succeeds in giving us a study in which there are all the elements of a good picture. A. Kinsley's "Across the Moor" (198) is bold and strong in colour; and we must also notice for its unaffectedness Alfred East's "Haverstock Hill" (187). John R. Reid's boat and fishing scenes are, as usual, brilliant and strong, but not such successes as his oils. "When the Boats come in (Scheveningen)" (201), "Waiting for the Boats" (363), "The Gipsy's Home" (208), and others in the East Gallery are at least fresh in colour.

A great many commonplaces meet us, as "The Music Lesson," and many studies of *genre* hard and crude that would have been better unhung, as Nos. 241, 248, 243, 256, &c. William Evans's child study (215) has simplicity; Henry Ryland's delicate fair maiden study, "Doris" (220), with her brown thick tresses and background of lilies, is dainty. Walter Langley's "Day Dreams" (227), a country woman outside her cottage door meditating, is one of the best subject pictures. J. Aumonier, in "A Chalk Cliff," has chosen a bold and striking subject. The sun illumines the cliff, which forms a background to a group of farm buildings and its pool. His other work is also pleasing and unaffected, and has a sense of atmosphere, as in "A Flowery Mead." "A Bridge on the Stour," by Yeend King (233), is a pleasing subject handled with care, and "Near Dartmouth" (281); and we must notice Arthur A. Dixon's "Dawn," a child's face (234); "A Savoy Garden" (256), by A. Parsons; a pleasing portrait of a girl, with a decorative motive, by Henry M. Rheam; W. T. M. Hawksworth's drawing of "An Old City Church," with its carved pulpit and sounding-board; Edgar Bundy's "Market Day," a clever group of country

folk in a country inn parlour—a characteristic study of faces; a sunny hillside sketch, "In a Swiss Garden, Lake of Zurich," by Miss Jane Inglis (327), are of interest. One of the cleverest pieces of *genre* is Mrs. Lydia J. Price's "The Première Danseuse" (365), a highly-amusing bit of drollery—Dutch dolls, with their wooden stare and expression, looking at a figure of a dancing girl, a piece of grotesque pleasantry that will provoke much mirth. H. E. Tidmarsh (404) has a good drawing of "St. Mary-le-Strand"; Terrick Williams has a nice grey evening effect (405); and C. Maciver Grierson's "An Old Maid" are clever. We need not say that Edwin Hayes, R.H.A., contributes several of his inimitable seascapes, as a "Guernsey Fishing Boat Entering Harbour" (366).

In the East Gallery, John Gulich's picture, "The Violin Concerto" (435), is unquestionably the highest piece of art in the room, though its handling and solid treatment is more suitable for the oil medium. The observer faces a vast orchestra in serried ranks during the most impassioned part of the performance. The central figure is a young and beautiful vocalist in white satin robe, taking the chief part; at her feet have been flung the choicest roses. The painter has endeavoured to realise the ecstatic delight and rapture of the melody by the hovering light which soars upwards from the songstress, and which seems to realise the very spirit or afflatus of music. With its faults of execution, there is much invention shown. A beautiful coast scene, "Aberdeenshire" (428), is by F. Stuart Richardson, the subtle blending of tones being charming. Edwin Hayes, "Fishing Boats, Hastings"; William W. Collins, "Easter Morn" (461); Miss Anna Nordgren, "Quand on est Jeune" (471); Dudley Hardy's sea-coast subject, "Last Load," are all pictures of interest. One of the chief works is Walter Langley's "In the Fishing Season," a group of fishermen on a beach of rock at the foot of cliffs. The same delineation of character, the same light and freshness, are seen in this as in former achievements, and the work will rank with many of them. A large picture, "Evening Dews and Moonset" (540), by Edward Read, realises the evening misty effect of dews under moonlight; James Orrock's large landscape, "Barford Mill, Warwickshire" (549), is one of the chief of his three contributions. There is the Constable-like manner we have noticed before in this master's treatment of foliage, a glittering dewy effect. Walter J. Morgan's large figure subject "A Reverie," a young woman in blue dress standing at an open window. The letter in her hand suggests the cause of her wandering thoughts. F. G. Cotman (551) sends a small but delightful sketch "From a Lowestoft Cliff." There is simplicity and nice drawing in Harry E. James's "Old-street, Amesbury," and R. B. Nisbet's grey-toned seascape, "Stormy Day on the East Coast" (555), must be mentioned. A large view of "The Cliff, Bagot Park," is by Fred. Mercer, a piece of bold forest painting. Luminous is David Green's fisher folk on sands "Waiting for the Tide" (559). Thos. Pyne has a careful but mannered study of landscape (563). The scheme of intense colour in T. Austen Brown's "By the Blue Sea" is strong; two girls, one stooping to pick up a pebble, are drawn with poetic power. The sea blue is intense, and contrasts strongly with the fresh face. Miss Louis Rayner (in 572) sends a careful drawing of Wrexham. J. Aumonier has several drawings of the Old Chain Pier at Brighton (573). Arthur Burrington has a large picture entitled "Cinderella" (611), in which the composition and colour are successful; and above it Stuart Lloyd has a view of "Worcester." There is some poetry in W. Lee Hankey's "Une Vierge" (636),

study of a peasant girl trudging home with her crook in the waning light of evening near the sea. The picture by G. Sheridan Knowles (499) is pretty and graceful in drawing and delicate in colour, and there are several other works of a pleasing but commonplace order.

#### MODEL SPECIFICATIONS.—IV.

##### DRAINAGE AND BRICKWORK.

WE now give plans of the drainage of two town houses, such as are built in ordinary streets (see plans 1 and 2). Both show a main 6in. house-drain laid beneath the basement floor to a sewer in front with 4in. branches. At the head of drain a chamber is built 2ft. square or more, which receives the discharge of sinks and wastes. Another manhole is built to receive the soil-pipe, and a disconnecting manhole 3ft. by 2ft. 6in. with intercepting trap with cleaning branch (already described) near the sewer end of drain. In specifying, the following clauses may be adopted:—

**Connection with Sewer.**—Due notice to be given to local authorities, and pay fees for connecting with sewer, and for inserting a galvanised iron flap for a 6in. drain, and making good to road, curbing, and pavement.

**Disconnecting Manhole.**—Build a disconnecting manhole, A, in area 3ft. 6in. by 2ft. 6in. in 9in. brickwork in cement on concrete lined with glazed bricks inside. Insert a Doulton's 6in. (or Hellyer's or Crapper's) stoneware intercepting trap having a 4in. cleaning branch with cap. On the concrete bottom lay a 6in. glazed channel invert (or half pipe) 3ft. long, and 4in. junctions. Form the sides and render in neat cement to even and smooth falls. An air inlet 6in. diameter to be introduced carried up area wall (or as directed), with iron grid or Hellyer's mica flap, or connect manhole to a 6ft. length of 4in. iron rain-water pipe fixed to wall, with approved outlet.

**Other Manholes.**—Build the other manholes, B and C in plan, 2ft. 6in. (or 3ft. by 2ft. 6in.), and at the proper depths with footings on concrete, and line walls with white glazed bricks, and connect the manholes with a 6in. (or 4in.) stoneware pipe laid to a fall of—in 10ft.—straight in line, and even in gradient. The pipes to be incased in cement concrete 18in. square when finished; the concrete to be hollowed out at every socket, so that the pipes may have a firm bedding. Or—

Connect with iron drain-pipes, well caulked and jointed with molten lead in concrete.

**Branch Pipes.**—Connect the feet of soil-pipe, rain-water waste, and gullies to the manholes with 4in. stoneware pipes, with proper bends, incased in concrete, and put Doulton's (or Hellyer's) gullies and traps where required, with iron grids in stone curbs, &c.

##### PRELIMINARY NOTES ON BRICKWORK.

In the construction of buildings many important points should be considered. First, as to dry walls. It has been calculated that ordinary cottage walls, one brick thick, consisting of 12,000 bricks, are capable of holding 1,500 gallons or  $6\frac{1}{2}$  tons of water. Hence the importance of damp-proof courses, dry areas, hollow walls, and other means of arresting the moisture to which brick walls are exposed. Where the ground or lowest floor is below level of outside soil, a dry area, or what is sometimes called an air-drain, becomes necessary. We give one or two sections of this arrangement (see sketch, e). The outer wall should be 9in. in cement, and the air-drain or space 12in. wide, covered by weathered flagstones (see section 2). A perforated damp-course or air-holes should be introduced beneath plate of joists, as shown, and air-ducts formed at intervals (see sections). Sometimes, when space is valuable, the inner brick wall can be protected from moisture by a vertical lining of White's Hygeian Rock composition between the two casings, as shown (section 3).

Damp-courses should be 6in. at least above external ground surface, and they should be placed under the lowest wall-plate. There are several kinds of damp-courses:—(1) Glazed pottery slabs (perforated), like those of Doulton, Jennings, &c.; (2) layers of asphalt 3in. thick; (3) slate in cement (two courses); (4) sheet lead (see Fig. 4).

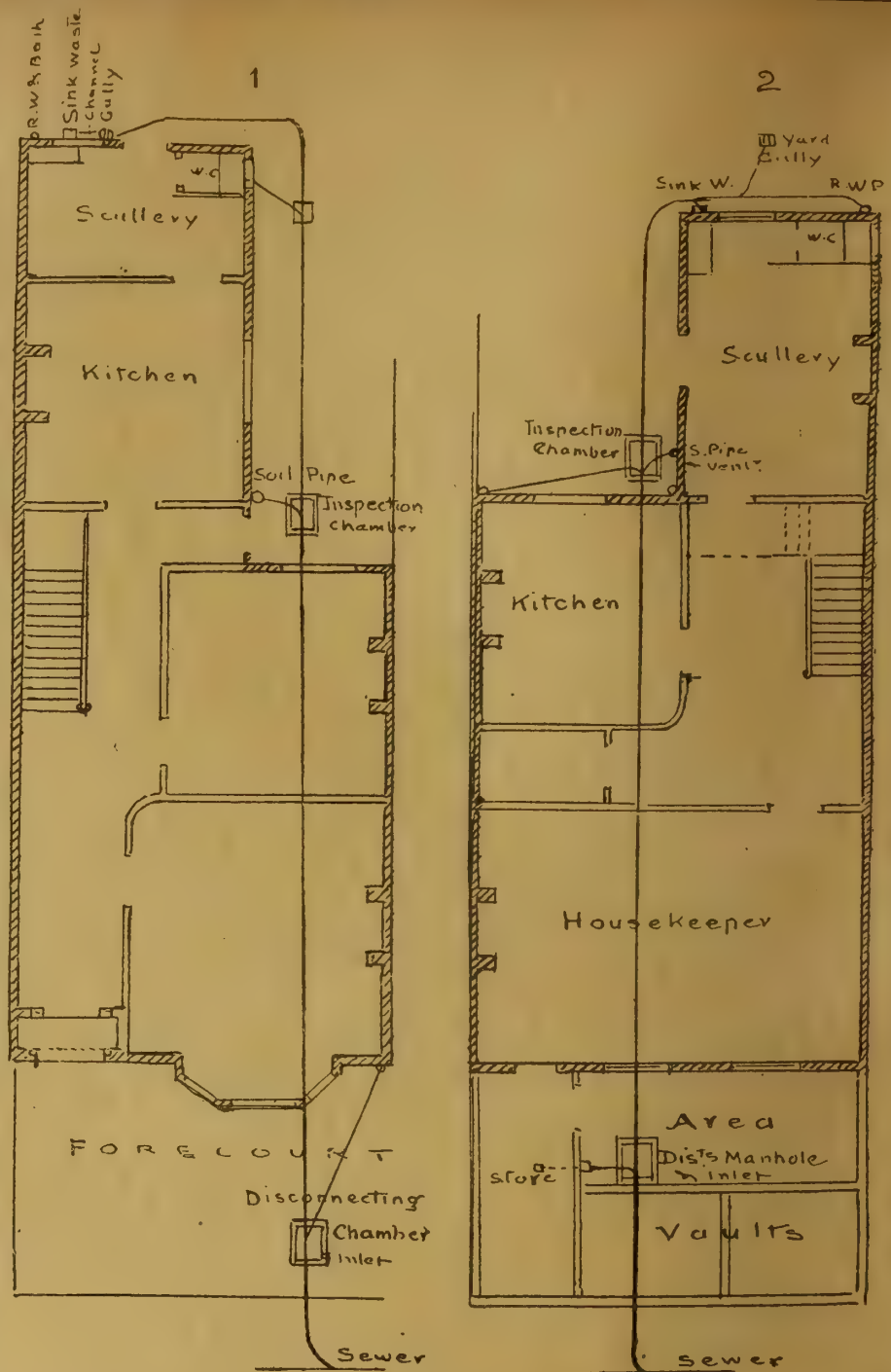

It is necessary, also, to put a damp-course in all brickwork above the roof-level, like stacks, parapets, gables, &c. The layer of asphalt or lead should be laid above the flashing of gutter in a parapet.

Footings should be built of hard, well-burnt bricks, and care should be exercised that the lower courses should be properly composed of headers, and that bats and broken bricks be avoided. They should spread on each side of the wall half the thickness of wall, and diminish in regular  $2\frac{1}{4}$ in. offsets. In specifications for important buildings it is necessary to describe in detail the number of single or double courses, and to insist that no bats or snapped headers be used in making the offsets. The lowest course should be double. Hard bricks and good hydraulic mortar ought to be used.

Bond, too, is important, and ought to be specified more fully than it is, especially in important buildings. We give plans of two kinds of brick-and-a-half walls. The first shows half-bricks in the centre of wall, and a three-quarter bat used in the inside. As it is plastered inside, this arrangement is admissible, and is strong (see b). The bond

shown at c is often used; it has a closer on each course, which weakens the bond internally, as shown by the thick line; b is stronger.

Then it is important to specify that the bond between a main wall and a thin cross-wall be so arranged by bats that the cross-wall is tied into the main wall (we shall show plans of this). If a half-brick inside wall join an outer brick wall, one course will simply abut against the main wall; but in the next course two bats are used at the end of the thin wall which runs right through the outer so that a bond is secured. Again, in 2 and  $2\frac{1}{2}$  or 3-brick outer walls the cross walls may be half-brick less in thickness. In every alternate course, the bond is secured by the cross wall entering into the substance of the outer wall, giving a one-brick tie. Then attention should be given to the arranging of the bricks at right and other angles. Generally a "closer" is introduced in each course, but in different directions. So also the bond at window and door openings ought to be specified. To prevent straight joints occurring between the reveal and jamb, "king closers" or



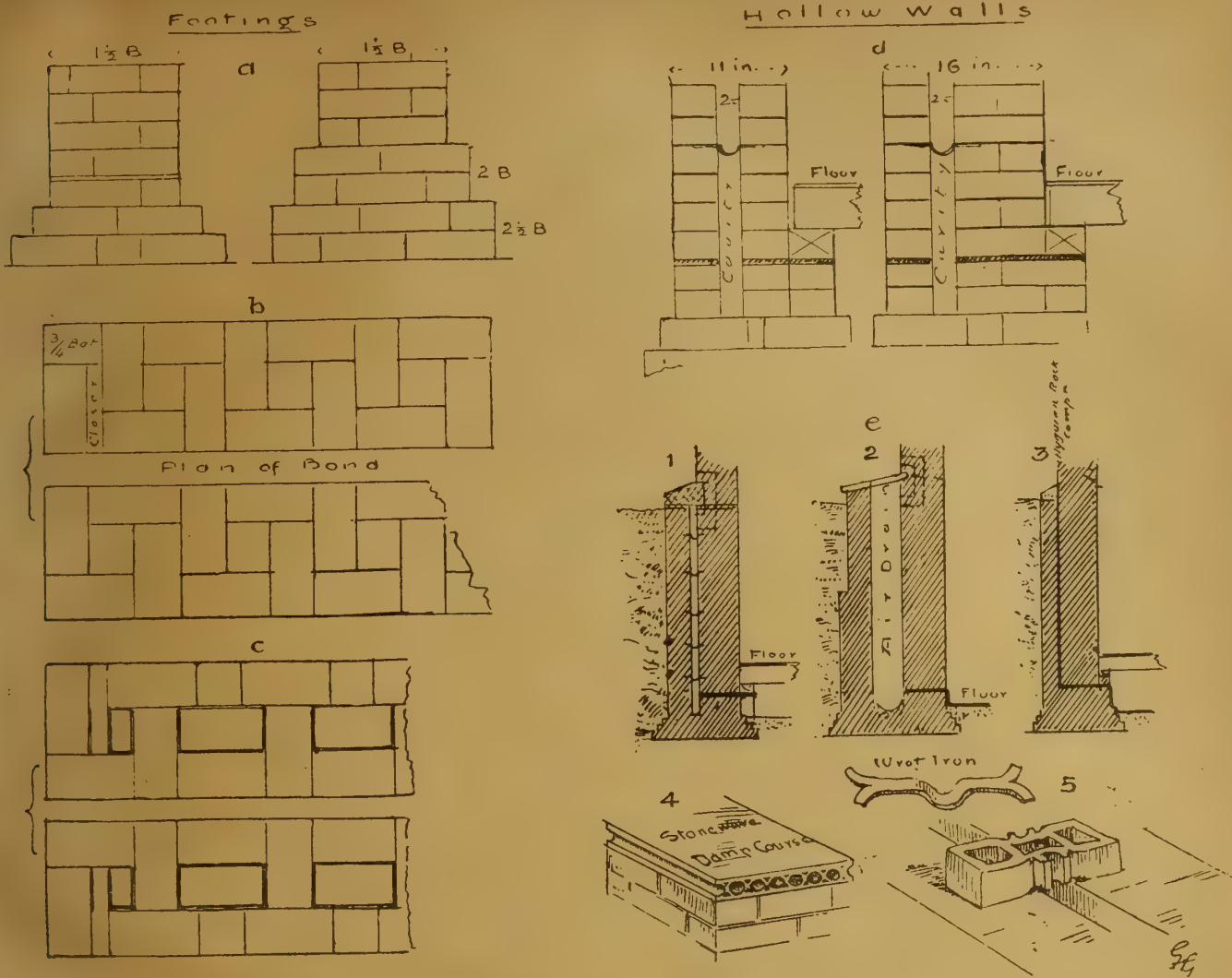

mitre-cut bricks are necessary at the inner angle between reveal and jamb. We show sections of hollow walls *d*, one 11½ in. thick, consisting of two half-brick thicknesses, and a cavity of 2½ in.; the other, one of 16 in., showing the 9 in. wall inside and a 4½ in. outside, with a cavity of 2½ in.

BRICKLAYER.

In a properly-prepared specification the bricks to be used should be described, naming the field or the manufacturer's name. It is necessary also to require a sample deposited with the architect, though this precaution is of little value unless the bricks delivered are carefully examined as they come in by the clerks of works.

The best building bricks used in London are called "stocks"; but they vary much in make, quality, and colour. Those called Malms are the best variety, and of a decidedly yellow colour, and from this circumstance and their evenness of texture are well adapted for facing-bricks, gauged arches, and dressings. Malms go under several names—cutters, best seconds, facing paviers, hard ditto, shippers, grizzles, and place; the latter are imperfectly burnt.

For superior buildings, where a pleasing stonelike tint is desired, the Suffolk whites are often used for facework. For good work in London the "Malm Cutters," "best seconds," or "facing paviers," may be used; but for ordinary building "Malm paviers" or "washed stocks" do fairly well. "Grey stocks," though not uniform in colour, make good fronts. For foundations, hidden, or rough work, rough stocks, grizzles, place bricks are employed. The best for red work are cutters or red rubbers, such as the Fareham Reds, or the well-known "T.L.B." made by Lawrence and Co., Bracknell.

A few general clauses on materials are the following:—

- 1. Bricks.**—The bricks to be hard, sound, and well-burnt, of even size, having a metallic ring when struck. Or—  
All bricks to be well burnt, of uniform size, square in shape, free from cracks, stones, flaws, and other defects, and equal to samples deposited with the architect for approval. Soft or "place" bricks will not be allowed to be used, and bats only to be used where necessary for bond. The external wall (or other portions shown) to be built with best London stocks (or malms), and to be faced with Suffolk whites (or Fareham "reds"). Or, in London—  
The brickwork generally, except when shown, to be executed in superior bricks, or hard, square well-burnt stocks (or approved grizzles).
- 2. Wetting Bricks.**—The bricks to be well wetted before being laid, and the joints to be well flushed up as the work proceeds.
- 3. Lime.**—The lime to be freshly-burnt Dorking (or Maidstone) stone lime, or freshly-burnt blue lias lime from Barrow or Aberthaw.
- 4. Sand.**—The sand to be clean, sharp Thames grit from above bridge, washed and screened and free from salt. Or—  
The sand to be clean, sharp, pit or river grit, free from loam or other impurities, and well washed.
- 5. Mortar.**—The mortar to be composed of fresh-burnt grey stone lime, and clean, sharp pit sand, in the proportion of 1 part lime to 3 (or 2) parts of sand, mixed and used fresh every day. Or—  
The mortar to be composed of fresh-burnt, slaked, and screened grey chalk or stone lime, and clean, sharp pit or fresh river sand, in the proportion of 1 part lime to 3 parts sand, measured in boxes, mixed dry on a wood or stone floor, and water added till the whole is incorporated and brought to a proper consistency.

(Sometimes clean broken brick rubbish is used instead of sand. This should be finely ground in a pug or mortar-mill.)

**Black or Blue Mortar.**—The blue (or black) mortar for pointing to be composed of 2 or 3 parts of blacksmith's ashes, finely sifted, and mixed with

three parts of grey chalk lime and 4 parts of sand. Or—

Two parts sifted forge coal ashes to 1 part of stone lime.

**Cement Mortar.**—For foundations, piers, and other portions of work shown, cement mortar is to be used composed of Portland cement, and gauged one part cement and three parts sand. Or—

To be composed of one part Portland cement and two (or three) parts sand.

**Putty for Pointing.**—To be composed of pure lime and clean, fresh water.

**6. Footings.**—To be built as shown on drawings, in English bond, with three or two projecting courses or double lower courses for 14 in. (or 16 in.) hollow walls.

**7. Air Bricks.**—Insert where shown (or directed) under all ground floors 9 in. by 3 in. (or 9 in. by 6 in.) terracotta or galvanised-iron air-bricks, and form and cement flues for same.

**8. Damp-Course.**—Lay at the proper level, as shown (or 6 in. above the outside ground), throughout the full thickness of all the walls and jambs, a course of Claridge's Patent (or Seyssel) asphalt ½ in. (or ¼ in.) thick, applied hot and sanded over. Or—  
Lay over the surface of all walls their full thickness Doulton's (or Jennings's) improved glazed stone courses, with tongue and grooved joints and proper angle pieces bedded and jointed in cement mortar. Or—

Lay over all walls, &c., a double course of stout Welsh slates, lapped at joints, bedded and jointed in wet cement ½ in. thick, the course of brickwork above and below being built in cement mortar.

**9. Brickwork.**—Build the walls, piers, chimney stacks upon proper footings (as shown on sections) with the best hard-burned London stocks (or other approved bricks carried up in English or Flemish bond) in lime (or gauged) mortar, to the several heights and thicknesses shown (or figured) on plans and sections.

Carry up the walls in a uniform manner, in English (or Flemish bond), no one portion being allowed to rise more than 4 ft. (or 5 ft.) above another at one time. Flush up each course with mortar (or grout every fourth course with liquid mortar). No four courses to rise more than 1½ in. besides the height of the bricks (or the joints to be ½ in. thick). All piers and quoins to be kept strictly true and

square, and the whole to be bonded in accordance with the rules of good work. Or—

**Bricks and Brickwork.**—All bricks to be well-burnt and of a uniform size, of the best quality of their respective kinds. The external, main, and party-walls to be built with well-burnt stocks; the external walls (marked) to be faced with malm of approved quality. The internal walls to be built with rough stocks (or grizzlies, or other approved bricks), and the footings and basements of rough stocks. Or—

**Hollow Walls.**—Build the external walls hollow in two thicknesses, 9in. brick on the inside (or outside), and 4½in. brick on the outside (or inside), with a cavity of 2½in. between, from where shown on section, or two courses below the damp-course to eaves level, and tie the two thicknesses together by wrought-iron cramp 8in. by ½in. by ½in. (or by bonding bricks of Doulton or Jennings), six of these cramps being used to a yard super. (or spaced 3ft. apart alternately to every third course). The cavity and cramps to be kept clear of mortar droppings.

Over all door and window frames in hollow walls put 4lb. lead built into both thicknesses, and beyond lintels 4in. on each side, and turn down at ends.

10. **Sleeper Walls.**—Build sleeper walls 9in. (or 4½in.) in cement mortar, to carry ground floor joists where shown on section, not exceeding 5ft. apart, pigeon-holed for ventilation. Or—

The sleeper walls to be half-brick (or brick thick) with footings, with openings left every 4ft. Or—

Build 14in. piers 5ft. apart, with footings, on a bed of concrete 6in. thick.

11. **Fender Walls.**—Round all fireplaces on ground floor, build, with proper footings, fender walls one brick thick in cement mortar, and fill in space with cement concrete for stone hearths.

12. **Half-Brick Walls.**—Build all half-brick walls with a tier of iron hooping, tarred and sanded (where necessary), inserted every 5ft. in height, and the courses above and below built in cement. Or—In cement mortar.

13. **Chimney Bars.**—Put to all fireplace openings 2½in. by ½in. strong wrought-iron bars, caulked and turned up and down at each end 6in. into the brickwork.

14. **Bed and Point Frames.**—Bed and point in lime and hair mortar all door and window frames. The hair mortar to be 1 part lime, 3 parts sand, and 1lb. clean bullock's hair.

**Generally.**—Bed in mortar all beams, plates, lintels, stone sills, &c., and make good after carpenter, mason, &c. The brickwork to be well pinned and backed up to all stone (or terracotta work), and to be cut and fitted at the ends of all joists, iron girders, &c.

## SANITARY WORK.—I.

### PRACTICAL DETAILS.

OF late years much attention has rightly been given to the subject of house-drainage and sanitation, so that it is scarcely necessary to discuss anew the broad principles which are intimately connected therewith. The present purpose is rather to direct attention to a few matters of constructional detail which may prove useful in carrying out drainage works.

It is now an accepted axiom that all drains shall be laid in perfectly straight lines from point to point (any bend or change of direction being arranged within a properly-constructed inspection chamber), and as far as possible with self-cleansing gradients throughout. Adequate provision must also be made for the proper ventilation of each length of drain and soil-pipe, whilst at the same time taking due precautions to prevent the possible entry of vitiated air from the drains into the building. An intercepting trap is fixed at the junction of the house-drainage system with the public sewer, so as to prevent the escape of sewer air from the latter into the house-drains. The materials and joints of all drains must be such that when laid they shall be quite air and water-tight, so that no air or sewage may escape from the pipes other than at those points where provision is made for such purposes.

The nature of the ground in which the drains are laid should receive careful attention, and all necessary measures taken to insure a firm seating for the pipes: otherwise, settlements and fractures may result from an unstable or improper foundation.

When the bottom of the trench is formed in hard, unyielding ground, such as compact gravel and similar formations, the pipes are frequently laid directly thereon. In loose earth, wet clay, &c., where there may be a probability of the pipes sinking with the pressure of the superincumbent earth or from other local causes, a bed

of Portland cement concrete should invariably be laid under the pipes, so as to provide an increased bearing surface.

For ordinary purposes the concrete is from 4in. to 6in. thick, and about 12in. wider than the internal diameter of the pipes to be laid. As a further precaution, the pipes are frequently well haunched up at the sides with concrete after the

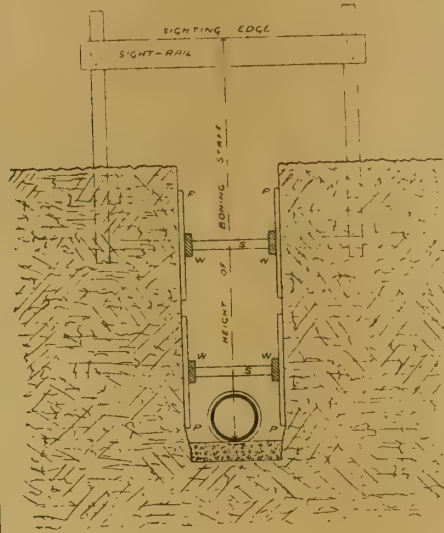

FIG. 1.

drains have been satisfactorily tested. By this means the resistance of the pipes to crushing or ultimate displacement is increased considerably, and further security provided against any chance of leakage in the drains themselves. Where very soft and treacherous ground is met with, it is desirable to use cast-iron drain-pipes, supported on stout creosoted fir piles driven sufficiently deep to insure a sufficiently stable foundation.

When excavating trenches in loose soil, proper shoring or timbering must be provided so as to prevent the sides from falling in. Fig. 1 illustrates the usual method of fixing the necessary strutting and planking. Short lengths of boarding (marked P.P. on sketch), about 3ft. long, and known as "poling boards," are placed vertically on each side of the excavation. These are held in position by means of a stout "waling piece" (W.W.) placed horizontally on each side of the trench, near the centre of the poling boards, the whole being firmly wedged against the standing earth with strong transverse horizontal "struts" (S.S.), spaced about 6ft. apart. As the excavation becomes deeper, another set of poling boards, walings, and struts are inserted below those previously fixed, until the requisite depth is

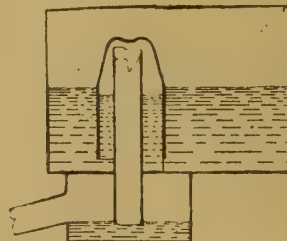

FIG. 2.

attained. Each set of poling boards, waling, and struts is technically known as a "frame," so that the illustration (Fig. 1) shows two "frames" of strutting and planking placed in position.

The poling boards are generally about 9in. wide, and from 1in. to 2in. thick, according to the nature of the ground to be supported. In very loose earth they are placed close together; but in comparatively firm ground they may be spaced from 2in. to 6in. apart.

The waling pieces consist of stout planks about 9in. wide, 3in. thick, and 12ft. to 14ft. long, whilst the struts are cut out of timbers varying from 4½in. by 3in. to 6in. by 6in. in section, according to the width of the trench and the nature of the excavation.

In Fig. 1 is also seen the elevation of a sight rail, the height of the boning staff used for laying

the pipes to the desired gradient being indicated by the dotted line. Sometimes the sight-rails are limewhited or painted black, so that the sighting edge may be more easily distinguished from the surrounding objects.

Where the exigencies of the site do not admit of drains being laid to self-cleansing falls, it is desirable to provide an automatic flushing chamber arranged to discharge by siphonic action at regular intervals. A siphon in its most elementary form consists of a bent tube or pipe, having arms of unequal length. When the short arm is dipped into any liquid requiring to be discharged, and the internal air removed from the siphon, the atmospheric pressure within the tube is then less than that on the outside, so that the external pressure of the air, acting on the surface of the liquid, forces the fluid through the siphon, which thus passes up the short ascending arm round the crown or bend of the pipe, and escapes down the long arm.

In the construction of flushing chambers the principle of the ordinary siphon has been ingeniously adapted by different inventors so that the whole apparatus may be automatic in action.

Fig. 2 is an illustration showing the general arrangement of Mr. Rogers Field's automatic siphonic-action flushing cistern. The long descending arm is here represented by a vertical pipe, the upper end of which is covered by a shorter tube of larger diameter and closed at the top. This closed tube or cap represents the short descending arm of the siphon. The lower end of the descending arm is arranged to stand slightly below the level of the water contained within the "trapping box" beneath, whilst the upper end is formed with a projecting lip. When the tank is being filled, the water at the same time rises within the annular space between the long and short arm of the siphon, whilst the confined air is forced through the slight water seal of the trapping-box below. So soon as the level of the descending arm is reached, the water overflows and passes down inside; but owing to the projecting lip at this point it is prevented from trickling down the side of the pipe, so that it falls clear into the water-pool below, carrying with it small quantities of the confined air. As the internal air gradually becomes exhausted, the pressure within the siphon consequently becomes less than the atmospheric pressure outside, so that the water in the tank is forced through the siphon with great velocity.

To insure the proper working of the siphon it is necessary that the descending arm shall be placed truly vertical; otherwise the overflowing water—instead of dropping clear of the sides—will slowly trickle down the side of the pipe and run to waste, the siphonic discharge not taking place. When properly fixed, these flushing cisterns or chambers will act efficiently, even though they be only very slowly filled with water.

Where flushing tanks are designed to discharge their contents automatically at comparatively long intervals, the water supply must of necessity be a mere dribble. Instead of fixing the usual form of ball-valve, or a regulator valve which is arranged to admit an even and unvarying flow of water to the tank, it is desirable, where practicable, to provide a "reversible ball-valve," in which the action is exactly the reverse of the ordinary ball-valve. These are so constructed that the supply of water is a mere dribble when the tank is empty, but as soon as the cistern is almost filled the valve is opened and allows a full stream of water to enter, so that the action of the siphon takes place immediately.

Another well-known automatic siphonic action flushing arrangement, patented by Messrs. Adams and Co., is shown in Fig. 3. In this case the upper end of the descending arm is covered with a cap which corresponds to the ascending arm of the siphon, whilst the lower end is deeply trapped, the outlet of the trap being slightly contracted at C. When the flushing-chamber is empty, the level of the water-seal in the trap is shown by the dotted line B. As the water-level in the chamber rises, the confined air gradually forces out the water composing the seal of the trap, which escapes into the drain. This continues until the water-level within the descending arm reaches the point A, when the imprisoned air endeavours to escape round the lower bend. The compressed air, on passing up through the water-seal, is checked at the point C, but rises with sufficient force or impetus to carry a small quantity of water with it, thus destroying the equilibrium of pressure previously maintained within the tank and siphon. The excess of atmospheric pressure accordingly forces the water

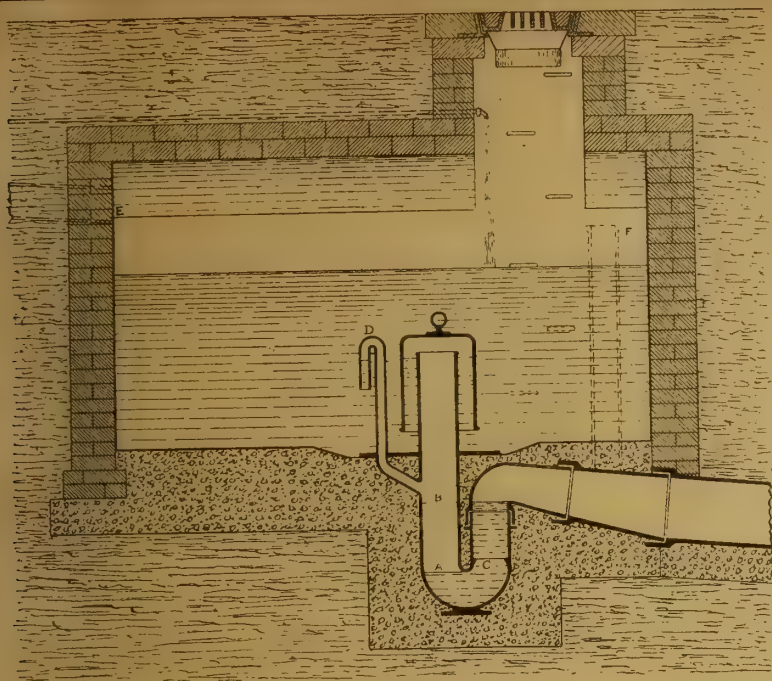

Fig. 3.

in the tank through the siphon, and the whole is rapidly discharged. A 1½ in. diameter vent-pipe with bend (D) is provided just above the water-seal of the trap. This confines the requisite amount of air within the siphon, and is designed so as to prevent a partial vacuum occurring within the siphon after the discharge has taken place, thus insuring the water standing at the normal level (B) within the trap. The siphon may be set in action by the smallest dribble of water.

In some cases sewage or storm-water is used for flushing the main drains, one or more branch drains being arranged to discharge into the flushing chamber, as indicated at E in the illustration. An auxiliary vent-pipe (indicated at F by dotted lines) may also be provided if desired. This is useful as a means of ventilating the upper end of the drain, and is so fixed that when sewage, &c., is used for flushing purposes it may from time to time be removed so as to allow any

egg-shaped section shown at F. The passing sewage is, therefore, concentrated at this point, so that the water has a greater power to force the solid matters through the dip or seal of the trap.

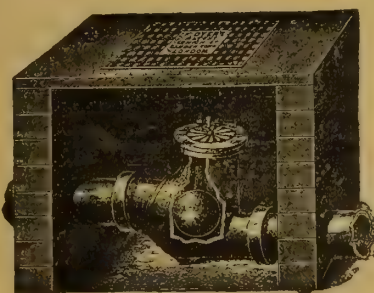

Fig. 5.

When the house drains discharge into a sewer which is subject to tidal influence, or liable to be flooded during very heavy storms, it is necessary to adopt measures for preventing the back-flow of sewage or water into the drains at such times. Some form of self-acting tide-flap or valve must therefore be provided near the outfall.

Fig. 5 is an illustration of Dyer's patent automatic tidal valve arranged within an inspection chamber. It consists of a hollow ball attached to a lever or rod so as to move freely at the slightest pressure. Under normal conditions the sphere remains suspended within the drain, and allows the unrestricted passage of sewage matters from the house to the sewer, but directly the sewage is headed back into the drain the pressure of the back-flow forces the sensitive ball against its seating on the pipe, and thus effectu-

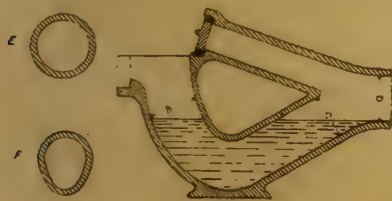

Fig. 4.

sediment at the bottom of the chamber to pass directly into the drain.

The thorough disconnection of the house-drains from the public sewer is another matter which must receive careful attention. An intercepting chamber, having a well-designed trap with a deep-water seal, should be constructed near the junction of the house-drain and the sewer. An air inlet for the continuous supply of fresh air to the drains discharging on the house side of the trap must also be provided.

The intercepting trap should be of a good self-cleansing type, with cascade inlet and a water seal of about 2 in. or 3 in. The cleaning eye of the trap should be fitted with a movable cap which can be readily removed and securely fixed without difficulty. Some of the best forms of intercepting trap are slightly contracted at the lower part of the trap, so that it may be more efficiently cleansed by the flow of sewage.

Another patented form of intercepting trap obtains the same self-cleansing effect by constructing the passage of the trap in an ovoid or egg-shaped section, as indicated in Fig. 4. The inlet and outlet are of the usual cylindrical form shown at E, so that the trap may be properly connected to drain-pipes of ordinary section; but the intermediate portion is gradually diminished until the passage between B and C assumes the

ally seals or closes the house-drain until the pressure on the sewer side of the ball-valve is removed.

All inspection or intercepting chambers should be fitted with a strong iron cover. For house-drainage purposes, solid covers and frames are

generally used, the entrance of fresh air to the drains being provided by means of a specially-constructed fresh-air inlet. Perforated covers, with dirt-box under—known as ventilating manhole covers—may be used for the admission of fresh air to the drains in suitable situations, but should not be placed near doors or windows, lest the ventilated drain become objectionable at any time, and so create a nuisance.

Numerous varieties of solid manhole covers are now obtainable. When selecting a cover for any particular purpose, it is necessary to take into



Fig. 8.

consideration the surroundings, and also the conditions under which it is to be fixed. Even when situated in the open air, and well away from inhabited buildings, the solid covers to intermediate manholes should be practically airtight, so that the air-currents between the properly-constituted fresh-air inlets and foul-air outlets of the drains may not be checked or disturbed in any way by the ingress or egress of air at other points. Where the manholes are necessarily in small areas or other confined situations, then not only should the covers be airtight for the reason mentioned, but it is essential—on the grounds of health—that they should be so arranged as to prevent the possibility of any escape of air or gases from the drain. Under such circumstances, particular attention should be given to the choice, and also the proper fixing of the frame and cover.

An efficient air-tight cover should be so designed as to be automatically sealed when closed, and at the same time the seal should not be liable to be broken in any way so long as the cover itself remains intact. It should also be strong, simple in construction, with few loose parts, easily fixed, and thoroughly secure against interference by mischievous or ignorant persons.

Figs. 6 and 7 are the plan and section of a single solid cover with a double joint. The inner groove of the frame is fitted with an indiarubber seal, whilst the outer groove may be filled with oil, glycerine, soft soap, or other suitable material. For additional security it is firmly fastened down by four gunmetal screws.

Double manhole covers should be fixed to all inspection chambers situated in confined places near the house, so that every safeguard may be provided against the escape of vitiated air from the drains.

Fig. 8 shows a section through a well-known patent double cover and frame for manholes. The inner cover is slightly arched, so that all moisture condensing on the under side runs down into

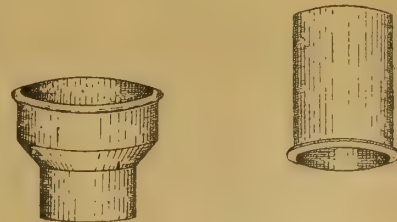

Fig. 10.

Fig. 9.

the adjacent groove. By this means an automatic water-seal is obtained. The inner cover is further secured by two locking bars (one at each end of the cover), so that it may be screwed down tightly into the groove. An air-tight joint is also provided to the outer cover by filling the groove with oil, glycerine, &c., thus affording an additional seal.

Lead soil-pipes should be connected to stone-ware drains by means of a strong brass tail-piece or ferrule (sometimes known as a "brass sleeve") passed over the end of the lead pipe and soldered thereto. The joint between the ferrule and the socket of the drain-pipe is then made good with neat cement.

The connection between the lead outlet of a water-closet and a cast-iron soil-pipe should be made in a somewhat similar manner, except that the joint is run with lead instead of being made good with cement. A brass ferrule is securely soldered to the lead outlet, which is then placed

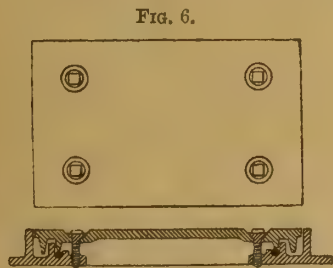

Fig. 7.

in the socket of the iron pipe, and the joint run with lead and well caulked.

Fig. 9 is an illustration of a brass straight ferrule. They should be of the quality known as heavy cast brass, well finished in every respect, and not less than 3 $\frac{1}{2}$ in. long for pipes of small diameter, so as to allow sufficient space for making the wiped joint at one end and a caulked lead joint at the other.

The following table gives the approximate weights of ordinary brass straight ferrules and tail-pieces used in sanitary work, viz. :—

APPROXIMATE WEIGHTS OF BRASS STRAIGHT FERRULES AND TAIL-PIECES.

Internal Diameter or Bore.	Length.	Weight.		
		Light.	Medium.	Heavy.
1 $\frac{1}{2}$ in.	3 $\frac{1}{2}$ in.	0 7	—	—
	4in.	—	0 9	—
	4 $\frac{1}{2}$ in.	—	—	1 0
2in.	3 $\frac{1}{2}$ in.	0 8	—	—
	4in.	—	0 11	—
	4 $\frac{1}{2}$ in.	—	—	1 4
2 $\frac{1}{2}$ in.	3 $\frac{1}{2}$ in.	—	0 14	—
	4in.	—	—	1 10
	4 $\frac{1}{2}$ in.	—	—	—
3in.	4in.	—	1 3	—
	4 $\frac{1}{2}$ in.	—	—	2 0
	5in.	0 15	1 10	—
3 $\frac{1}{2}$ in.	6in.	—	—	2 7
	7in.	—	—	3 10
	8in.	1 11	1 13	—
4in.	6in.	—	—	2 12
	7in.	—	—	4 10
	8in.	1 14	2 4	—
4 $\frac{1}{2}$ in.	6in.	—	—	3 2
	7in.	—	—	5 8
	8in.	—	—	—

The connection between the earthenware outlet of a water-closet and the lead branch of a soil-pipe must be made by means of a stout brass socket or thimble. The socket is secured to the

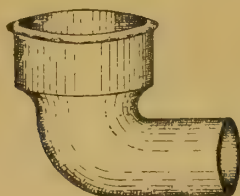

FIG. 10A.

lead pipe with a wiped solder joint. The closet outlet is then placed in the brass socket, and the joint carefully made with neat Portland cement.

The brass socket connection as ordinarily used is seen in Fig. 10, whilst Fig. 10A is a sketch of what is known as an elbow brass connection or

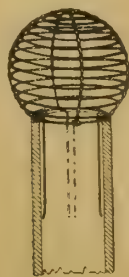

FIG. 11.

thimble. The approximate weights of ordinary brass thimbles or socket ferrules are as follows, viz. :—

APPROXIMATE WEIGHTS OF BRASS THIMBLES OR SOCKET FERRULES.

Internal Diameter or Bore.	Length.	Weight.		
		Medium.	Heavy.	Spigot End.
2 $\frac{1}{2}$ in.	3in.	1 6	—	—
	3 $\frac{1}{2}$ in.	—	—	2 6
3in.	4in.	2 0	—	—
	4 $\frac{1}{2}$ in.	—	—	2 10
3 $\frac{1}{2}$ in.	4in.	2 5	—	—
	4 $\frac{1}{2}$ in.	—	—	3 0

Copper and gunmetal ferrules or thimbles are also sometimes used. It is most important that the connection between pipes of dissimilar materials should be made in the strongest and

best possible manner. Neglect of such precautions might otherwise endanger the health of the occupants of the building.

The tops of all ventilating pipes should be fitted with a copper-wire grating or cage, so that the opening may not become blocked with birds' nests or falling leaves. Fig. 11 is a sketch showing the form of wire grating generally adopted.

ARCHITECTURAL ASSOCIATION.

THE fortnightly meeting of the Architectural Association was held at 9, Conduit-street, W., on Friday evening, the president, Mr. Hampden W. Pratt, F.R.I.B.A., in the chair. Two nominations for membership having been read, Messrs. A. T. J. Harris, of Croydon, and H. Wyllie, of Rochester, were elected as members. A vote of thanks was accorded to Mr. C. W. Stevens for permitting a visit to members to Claridge's Hotel, Bond-street, W., of which he is the architect, on Saturday, February 28th, Mr. E. Howley Sim, hon. secretary, remarking, in proposing the motion, that that building had proved a most interesting one.

SCOTTISH CHURCH ARCHITECTURE OF THE FOURTEENTH AND FIFTEENTH CENTURIES.\*

A paper on this subject—illustrated by large scale plans, elevations, and details, some of which were taken from Messrs. Ross and McGibbons's recent work on "The Ecclesiastical Architecture of Scotland," others being contributed by students to the "Edinburgh A.A. Sketch-book," and others executed by the author—was read by Mr. Hippolyte J. Blanc, R.S.A., past president of the Edinburgh Architectural Association.

To attempt anything like a detailed or systematic examination of the church architecture of Scotland of the 14th and 15th centuries is not, he said, intended. The variety of detail those periods exhibit makes their study very interesting, but there is too much in them for one evening's review. I hope to satisfy you with a sketch of some of the most prominent examples, which may form leaders to much of like form and detail to be found in many smaller works, and to endeavour, as far as possible, to assist you in your knowledge of the English work of the same time, to compare, from the illustrations, the contemporaneous architecture in Scotland. One cannot pretend to be very accurate with regard to the precise dates of each and all of the examples selected, because of the special difficulty all students of Scottish work have experienced in chronologically placing works of those periods. This particular period of our church examples has been chosen because the church work of those centuries (and for that part the first half of the 16th century also), is

MORE DISTINCTLY SCOTTISH

than can be said of the works of the centuries preceding. The most casual observer of church forms and details of the 11th and 12th centuries in France and in England will readily trace their genesis in the one country, and their acceptance and adoption in the other. During the early

\* The following illustrations of the buildings described by Mr. Hippolyte J. Blanc have appeared in the pages of the BUILDING NEWS:—Aberdeen, Old-King's College Chapel, tower and crown spire, Feb. 23, 1872 (by J. Malcolm), and Dec. 31, 1897; stalls (measured drawings by P. Auld), April 1, 1870; St. Machar's Cathedral, western towers, Jan. 27, 1871; Costorphine Church (John Stewart), May 9, 1894; Dunblane Cathedral (perspective by J. B. Tyerman), July 24, 1886 (nave interior, by James B. Gibson) July 24, 1885; windows (E. F. C. Clarke), May 20, 1870; stalls (ditto), June 18, 1869; Dunfermline Abbey, plan of monastery buildings (the late E. C. Mackenzie Walcott), July 15, 1870; interior and north porch, April 14, 1893; section, April 8, 1896; Elgin Cathedral, east front (James B. Gibson), July 24, 1885; Glasgow Cathedral, perspective (Jas. Glen), April 26, 1884; Holyrood Chapel Royal, Edinburgh, April 10, 1896; arcaiding (J. Russell Walker), Jan. 28, 1870; capitals (ditto), March 18, 1870; Kirkwall Cathedral (section), April 3, 1896; Melrose Abbey, sketches (W. Canning), Jan. 21, 1881; measured drawings (Fred. J. Waas), February 5 and March 26, 1897; east end (John Begg), August 2, 1889; south transept (T. Lennox Watson), September 7, 1869, (John Begg), May 17, 1889; Midcalder Parish Church (Hippolyte J. Blanc), April 26, 1889; Paisley Abbey, measured drawings (T. Roger Kitzell), March 9, April 13, and June 22, 1888; Pluscarden Priory, measured drawings (Alex. Macintosh), April 4 and August 1, 1890; Roslin Chapel, north and south sides, December 31, 1897; north door (from water-colour drawings by Patrick W. Adam), April 28, 1893; interior (J. B. Tyerman), July 24, 1885 (John Begg), April 12, 1889; ditto from photos, showing Lady Chapel and 'Prentice Pillar, Feb. 19, 1892; St. Andrew's, St. Salvador's Church, December 31, 1897; St. Monance, Fifeshire, plans and measured drawings (J. Russell Walker), March 20, 1891; sketches (John Begg), August 2, 1889; Stirling parish church interior, December 31, 1897.

part of the Middle Ages, when, under the freshness of enthusiasm, Christian emigrants rapidly spread themselves all over Europe, Scotland also received the foreign influence, and readily accepted the progressive developments of architectural forms and details which the church-building fraternities brought with them. I do not suppose that anyone has contended that Scotland during that early period struck forth a style of her own, or even expressed then any very distinctive individuality in her treatment of churches; rather she adopted, under the guidance of her church patrons and founders, characteristics from both France and England. During the Romanesque, Norman, and First Pointed periods of church building, there is an evident parallelism in the works of France, England, and Scotland, even to the 13th century. In England church builders accepted the leading from France, while there are evidences of some individuality in treatment of details. In Scotland the French influence for long was strongest. In England the general proportions differed from those in France: English cathedrals of the 12th and 13th centuries are wider, but not so lofty as are those of the same era in France. In this matter Scotland appears to have followed more closely the French models. English work shows more restful consistency and stolidity, but seems to lack the rich grace and elevating continuity of forms—the emotion—of French examples. Whether Scotland in her works of that early time ever reached the great flights of skill and poetic expression witnessed in the French examples, we have perhaps lost the means of determining. Wherever, however, remains of her early works are found, there is enough to show that, while her buildings could not vie with those in England in respect of magnitude or richness, yet, as regards elegance of composition and expression of disciplined refinement of detail, the abbeys and cathedrals of Scotland can claim equal merit; they possess the same grace; they show the same skill in execution. Her church designers have exhibited equal ability and her artificers show themselves to have been equally capable with those of other countries during all periods up to the end of the 13th century. In Scotland

THE BUILDINGS WERE FEWER AND OF SMALLER DIMENSIONS.

Chronologically they are several years later than are the English examples, but in plan, general treatment, and in the order of development they do not differ much from their prototypes. As illustrative of the differences of dimensions of contemporaneous cathedrals in England and Scotland the following examples may serve :—

York .....	524ft. in length	St. Andrew's .....	358ft. in length
Lincoln .....	482ft. "	Glasgow .....	283ft. "
Salisbury .....	474ft. "	Elgin .....	282ft. "
Durham .....	461ft. "	Kirkwall .....	218ft. "

Scotland's equal pace with England in the progress and expression of her church architecture is readily understood when we know that at this time the Norman barons, who, encouraged by David I., and tempted by extensive gifts of lands, spread and established themselves and their families all over the better parts of Scotland, following the great example of "that sair sanct for the Crown," founded bishoprics, and for centuries became patrons and superiors of bishops and also liberal founders of abbeys. Those noble Norman lords and knights carried with them from time to time, along with a love of war and the chase, a strong desire to foster the arts of peace, more especially in the form of church building. We find them liberally encouraging the Church in turn by gifts of lands, &c., in which such abbeys as Paisley and Melrose shared very largely. Parish churches also, as were required, were built by those barons, and were afterwards, by consent of the bishops, conferred in perpetuity upon the great monasteries and religious Houses of Regulars. The singular uniformity characterising the ecclesiastical buildings of the 12th and 13th centuries would seem to indicate that fraternities of church builders assisted in rearing the beautiful edifices found over Europe. Rickman reminds us that when Early Gothic was developed the whole western provinces of France were under the dominion of the English Crown, and that Normandy had been for a century or more part of the same kingdom. Thus Norman knights and churchmen would find ready access to England and Scotland, and carry with them the progressive development of church style. In many cases we know that monastic buildings in Scotland were subject to the rule of the French monasteries

from which the communities branched; but, as if anticipating Pope, who enjoins:—

Who builds a church to God and not to fame,  
Should never mark the marble with his name.

the architects of those great cathedrals have not left any record of their names. If, as we assume, those buildings were the outcome of an aggregation of thought by fraternities, the explanation is apparent. There is no doubt that churchmen studied architecture, and were for the most part architects of their own buildings, being aided and counselled in matters of taste by the members of church-building fraternities already referred to. The

#### INFLUENCE OF ENGLAND

at this time upon our Scottish church architecture must have been likewise very important, because we know that the clergy who served in the Scottish churches were either priests from England or kinsmen of the Anglo-Norman founders born in Scotland. "Of the fifteen prelates who were elected to the primatial See of St. Andrew's during the 12th and 13th centuries, and designated themselves 'episcopi Sctorum,' not one appears to have been a Celtic Scot. Only a few sprang from the Anglo-Norman houses of Scotland, the great majority being Saxons and Normans from England." There must have been interchange besides, because we are informed that monks from Melrose became abbots of the Yorkshire monastery of Rievaulx, the parent house; Melrose also sent abbots to other Cistercian houses, including Kinross, Cupar, Newbattle, Deer, and Balmorino. Those warlike nobles, patrons of the Church, always in a state of preparedness for war, became the natural protectors of the unarmed monks, who thus enjoyed unmolested security in pursuing their building operations. The influence upon the country by the building of an abbey was great. A long period was usually required for the work, and during that time its members were continually in the midst of the practice of all the arts—painting, sculpture, and architecture, as well as of the ornamental hand works, for these were all practised together. The highest taste was thus cultivated, to be disseminated for the greatest good of the country. To these influences may be added zeal for religion, a high ideal, a generous rivalry between convents, and a desire to render the Church ritual magnificent—each and all of which gave impetus to church work in Scotland, and kept it full of vitality and abreast of the best work found elsewhere. The industrial and social life of Scotland up to the 13th century were likewise in a flourishing condition. The burgher and trading classes amassed great wealth, and gave generously of their lands and means to the Church. Scotland was thus a centre of intellectual cultivation, and enjoyed at this period more peace than fell to the lot of English monarchs. But all at once all these favourable conditions changed. By the sudden death of one of her most enlightened kings, Alexander III., in 1286, Scotland's lamp of prosperity and progress was unhappily extinguished, only to be rekindled after a long interval. The succession was now brought to open dispute. England essayed to adjust the matter by placing a king under vassalage to her. This was resented, and wars followed between England and Scotland, and it was only towards the close of the 14th century that Scotland began to show signs of returning restfulness and prosperity. The effect upon Scotland's architecture was disastrous. Scarcely any new buildings were undertaken, and by the wars many of the finest of those existing were greatly damaged. Her patrons—the wealthy nobles—had left the country, many to espouse the cause of England's kings, to whom, after the death of Alexander, they had sworn fealty. During that interval of strife—upwards of eighty years—England's church architecture had developed new features, passing out of the First Pointed to a new phase—the Decorated or Middle Pointed. But when

#### SCOTLAND RESUMED HER CHURCH BUILDING,

her schools of church builders had passed away; consequently, she had to go back, and, so to speak, reconnect the thread of architectural evolution from where she had left it in the 13th century. Even the monks had been cast adrift, to find elsewhere the help their homes could no longer afford. In the beginning few churches were built; but gradually, as returning prosperity increased, Scotland became alive to what she had lost in art, and in the 15th century she came forward with

renewed vigour in the expression of a series of churches distinctively of native growth and development. The perfect First Pointed period, with its refinement and purity, its gracefully clustered shafts, lofty groined roofs, and elegant carvings was, in England, virtually obsolete. A style more massive had taken its place, the distinctive features of which were a greater exuberance of ornamentation, wider fenestration with elaborate cusped tracery, pinnacled buttresses, profusion of niches on walls and buttresses, &c. All these were matured, and were even passing out of English practice when Scotland commenced again her church work. England had actually entered upon her phase of the Perpendicular. France, with the buoyancy and vivacity of the race, rose out of her Decorated work into the flow of a restless form designated Flamboyant.

#### ECCLECTIC ADAPTATION WITH ORIGINAL TREATMENT.

Along with the examples of First Pointed in her midst, Scotland had the association of the Decorated and Perpendicular of England and the Flamboyant of France, on which to draw for inspiration. The result is not an adoption of either, but a sort of adaptation of all, in which the work of the Decorated period predominates. Thus Scottish artists struggled bravely to regain for her a parallel place with England, and, though here and there comparatively unsuccessful, much of her Later work of the 15th century and of that entering upon the 16th century exhibits a return of the native talent for graceful expression and skilful execution. Of the contemporaneous works of England and France no doubt Scotland assimilated a good deal; but in all cases it would appear that she gave an independent character to the *réchauffé*. Thus her Perpendicular work, which is chiefly found at Melrose Abbey, with a scattered fragment here and there over the country, can scarcely be said to be merely a repetition of that in England. Moreover, with regard to the French influence of the Flamboyant of the same period, it will be found that Scottish examples really show very little of the actual forms of that period. The forms of window tracery, for instance, might be described as a transition between Decorated and Flamboyant. The construction is heavier, but the forms are more restrained than in the French examples, and are by no means inelegant. From a few examples of these on the screen we may be able to verify this. Of Decorated buildings there are few complete in Scotland, or executed while that style was in practice in England. The Decorated style, however, lingered very late in Scotland, examples being found up to about 1462. The later examples are not so successfully treated, however, the best work being found in Lincluden, Crossraguel, the nave of Glasgow, Elgin Chapter-house, Linlithgow, and part of Melrose. After the date named the work in Scotland became very mixed and degenerate, and under later influences began to show an infusion of the contemporaneous work of her Southern neighbours. During the centuries under review no cathedrals nor conventual churches were founded, yet many alterations and additions were made to those existing. To Glasgow Cathedral was added the upper part of the nave in the beginning of the 14th century, while the sacristy, the tower, and the south crypt were added in 1425 and 1500 respectively. In these is manifested the lingering attachment of the Scotch to earlier forms, all beautifully beaded in a most interesting manner with details of a later period. But decaying piety and the comparatively diminished resources of the country brought about a reduction in the dimensions of her works. Hence we find, as fewer clergy were required, Scotland's chief works are the

#### COLLEGIATE CHURCHES AND CHAPELS,

of which nearly forty were founded in the 14th and 5th centuries. David Laing says there were thirty-six erected all over the country in the 15th and first half of the 16th centuries. They present in their detail nearly all that is characteristic of the period. Many of them no longer exist. They were built and endowed for a society of priests, commonly in a place having no episcopal see. The society consisted of a dean or provost, or other president, and, under them, prebends or canons who had in the church several degrees or stalls, where they sat for the more orderly singing of the canonical hours. They were instituted for performing divine service, for singing mass, vespers, &c., for the founders. They were divided into two kinds—one of Royal foundation, whereof the king was patron, con-

ferred the prebends, named the provost or dean, and the canons or prebendaries; the other the foundation of barons, who, of their means, bequeathed grants to the Church for singing of Mass for the repose of the dead. Both in their services were regulated as in cathedrals, but were not under cathedral chapter control. Generally,

#### THE PLAN IS CRUCIFORM,

or intended to be so (because a great many have never been completed), and comprises a central, or sometimes a western, tower, a sacristy on the north side of the chancel, and a porch on the south side of the nave. There is but one example of a building with twin western towers—that of St. Machar's at Old Aberdeen. In one or two instances—as at St. Giles's, Edinburgh—there are chantry chapels, sometimes the addition of pious founders. Aisles are not common except in the largest of them. Roofs are plain, arched with ribs, but rarely groined. In one case—Roslin—the stone arch has no other external covering. In roof-treatment there are many very interesting and quite unique features. Over the vaulting is laid a series of overlapping and guttered blocks of stone in parallel squares, in some instances at very high pitch, and in others very nearly level, with but a slight elevation for water-run. This form of construction involved much difficulty in cases where transept or chapel roofs rose up upon the nave roof. In such cases, each section of the building was treated independently with gabled termination. This feature is met with all over Scotland, and seems specially a Scottish invention, being perhaps originally designed for her castles of much earlier date. It is not much met with in English work. The forms of most of the buildings of this period being chiefly aisleless structures, gave special prominence to the

#### WINDOWS.

These were large, and arch-headed, of two, three, and four lights. They were not lofty, however, evidently to avoid the necessity of cutting in upon the interior vaulting, and necessitating cross-vaulting with its more intricate construction. In England, even, we find that notwithstanding the greater richness their works express, the groined vaulting has given place to plain surface vaulting, but decorated with a superfluity of ribs which are merely ornamental. In the same way, while we have a few examples of good vaulting such as in the south crypt of Glasgow Cathedral, in Trinity College Church, Edinburgh, and in the collegiate churches at this period—ornamental ribs are here and there found applied to surface vaulting, merely to give distinction to the choir or other part of the interior of the building—such as the chancel at Seton Church. Other examples of this are at Melrose, and St. Mirren's aisle or Chapel, Paisley. In Linlithgow and Stirling Churches may be seen some interesting manifestations of ingenuity in overcoming the difficulties of vaulting over the apsidal terminations of the choirs. Fan vaulting is not found in Scotland. Roslin Chapel, already referred to (the plan of which resembles very closely the character of the choir at Glasgow Cathedral in its aisles and retro-choir), bears the simple pointed-arch vault. It is, however, profusely decorated with ribs rising from the main piers, and, on the fields between, with an exuberance of carving, quite unique. The side aisles are vaulted at right angles to the choir vaulting, and in this way a greater elevation than would otherwise have been available is obtained for the windows. This chapel was founded in 1446, and while bearing in its charter that it was built by workmen from foreign parts, it possesses all the evidences of being of home manufacture. The details in moulding are those found on other collegiate churches of the period. Its buttress-shaped quasi-porches are quite unique and thoroughly Scottish. For richness and interest in carved work it stands unequalled, in view of its small dimensions are considered, and in view of the fact that about this time (1446) French masons were numerous in Scotland, it is possible some were employed upon Roslin. This would explain the charter notice referred to. Each bay of the aisles is spanned by a pointed arch, springing from a richly-carved flat one, from which the relative vault springs. As formerly noted, while the Scottish churches of this period are designed to have nave, choir, and transepts, in many cases the nave has never been erected. A feature almost confined to Scotland at this time is the polygonal termination of the choir. It is to France, where it was very common, we must look

for the prototype, for in English work it is not found in the Late period, though Wells Cathedral possesses it. Of that form we have many examples, some showing externally merely a continuation of the main roof; others projected from the terminal gable of the choir as a bow-window. Of side chapels there are several; but they are either formed as quasi-transpts, or, as at Melrose, out of duplicating the south aisle of the nave in the same way as at Coutances. E'gin appears to have had chapels similarly constructed. Other features, such as sacristies and porches, are noticeable in the work of this period—two of the porches—namely, at Linlithgow and Aberdeen, being remarkable for the possession of an upper priest's chamber or parvise, with a turret stair conveniently placed to reach them. In doors of this period we have examples of the features of nearly all the preceding styles. But it is noticeable that the round arched form is found most frequently through all the periods of Scotch Gothic. In detail of moulding it, nevertheless, usually conforms to that of the style of the building to which it is attached. Of double or twin doors of the period, we have interesting examples at Haddington and also at Linlithgow, both of totally different character, and seemingly of different dates. Upon this

#### QUESTION OF DATES,

however, it is very difficult sometimes to trace the period of execution of the several parts from their mixed character. Defined as are the early periods, it cannot be said that the later are equally so. There is no line of demarcation marking the change from the Decorated to the Third Pointed in Scotland, such as one finds between the Decorative and Perpendicular in England; the movement is so gradual in Scotland. In external detail the Scotch Decorative period follows largely the suggestions of both England and France. Mouldings are, however, broader in treatment, and carving not generally so fine. There are many exceptions, however, and very often one comes across an interesting monument or sedilia, designed and carved with such richness as to be suggestive of French influence of later date. Of such we have excellent examples in Bishop Kennedy's tomb at St. Andrew's and elsewhere.

#### THE TOWERS

of the period are very interesting, though perhaps not elegant. Placed at the crossing of nave and choir, or at the west end, they are usually sturdy features of a great variety of form and finish. They are rarely at this period extended as spires, though the two at Aberdeen Cathedral have spires in rather stunted form. The most interesting form of termination of towers we possess is the crown, as at Aberdeen College and St. Giles's, Edinburgh. Two others—at St. Michael's, at Linlithgow, and at Haddington Abbey—existed on a smaller scale, but were thoughtlessly recommended to be taken down through an unwarrantable fear of their giving way. The origin of that feature has not been traced; but one example, somewhat more elegant than our Scotch examples, exists at Newcastle. It is in the windows, however, that we find the best expression of this period. There are many examples of pure Decorated work at the beginning; but as the 15th century progressed, the influence of the French Flamboyant manifests itself. The tracery is heavy, often clumsy, and in many characteristic examples the cusped foliations are wanting. Forms are likewise traceable to English examples of a much earlier period. Instances of Geometric design are found at Melrose, Dunkeld, Paisley, Tain, Crossraguel, and Torpichen, and the reticulated pattern is found at Dunfermline Refectory. There are few of the English Third Pointed or Perpendicular type. Melrose, perhaps, bears the nearest approach to it, while in a less degree are other examples at Stirling, Linlithgow, and Corstorphine. At Melrose the south transept window with its gable is rather a successful, and almost unique, example of the combination of Perpendicular, Flamboyant, and Decorated types. Of carved woodwork we have, unfortunately, very little left us of the period. An easy prey to fire, it is scarcely to be expected that much would escape in the track of the wars of the 14th century. At Dunblane, however, we still possess a portion of the stalls, which is traced to be of late 15th century or early 16th century, and at Aberdeen and Tain respectively we have very characteristic pieces in a group of stalls and screen, and in a pulpit. The latter had become

dismantled, and the carved parts scattered among the townspeople. They were, about 20 years ago, collected again, and reconstructed in the original form by the writer. The original pieces were nearly complete. Such, then, is a sketch of the outstanding distinctive features of Scotland's church architecture after the close of the 13th century—a sketch which it has been thought well should comprise the gradually diminishing few churches erected in the early part of the 16th century, prior to the Reformation. The last of these—a collegiate charge—was founded in 1545, and was scarcely finished when the Reformation became a completed act to turn the tide of church building into new channels. Perhaps it is as well something did happen in the cause of art. This dying specimen, debased, perhaps, in everything but in plan, bears evidence of a sad falling off in artistic qualities. It is a mere shadow, and a distorted one, of the many fine and characteristic details of preceding examples. But it seems as if it had become aware of its impotence, and so unpretendingly evolved a structure to meet certain requirements, heedless of its art value. I trust that in your review of the buildings described and illustrated I may be permitted to anticipate that you will, as I have done, recognise that in its work, Scotland has sustained the

#### RACIAL CHARACTERISTIC OF STURDY INDEPENDENCE,

though expressed sometimes at the expense of elegance. The English work of the same type, busy with many small members in mouldings, attenuated arcades supported on elegant but rather reduced shafts, does not seem to have appealed to the Scottish mind. The Scotch seem to have preferred the strength and solidity of their earlier works, continuing the cylindrical and polygonal shafts in arcades, even to a very late period, and in nearly every case they exhibit a mastery of the art of masonry construction quite commendable. It must be recognised that Scotland laboured under very special disadvantages from its prolonged internal disturbances. These severed her continuity of art study and culture, yet her work bears the impress of a vigorous effort having been made to regain her place in the art of church architecture. I do further anticipate, however, that, while her works may be judged as exhibiting an absence of the refinement shown in the works of her Southern neighbours, it must be remembered that in England and France political conditions were more favourable to an unbroken development of art. Where work of any magnitude had to be done in Scotland, however, the results (such as at Melrose) show that the intelligence and ability to apply appropriately and skillfully available architectural details, and at the same time to give the impress of her own independent mind upon them, had not entirely died out. Mr. Blanc further illustrated his address by showing on the screen over seventy lantern-slides of the principal churches described, including reproductions of plans and sections, and also photographs specially taken by himself. In this way the churches of St. Monace, Fifeshire; Dalkeith, Stirling, Seton (chapel), Trinity College, Edinburgh (now demolished); White Kirk College (chapel), Lady Kirk, King's College, Old Aberdeen; St. Michael's, Linlithgow; St. Giles, Edinburgh; St. Machar's, Aberdeen; Elgin, Glasgow, and Dunblane Cathedrals, Roslin Abbey, St. Salvador at St. Andrew's, and Haddington, Paisley, and Melrose Abbeys were vividly illustrated, and attention was called to the characteristic features—to the curious commingling of Flamboyant and Decorated detail, and the massive central mullion in the fenestration, the persistence of the round arch, the stone blocks used as roofing over a vault, the conical dwarf spires piercing the towers, and the polygonal east ends—in such a manner as to impress the peculiarities of Later Scottish work indelibly on the minds of all.

Mr. J. M. BRYDEN, in proposing a vote of thanks to the lecturer, remarked that it had been one of the most interesting papers read in that room, whether before the Institute or Association, for very many years. There was evidently a strong French feeling in all work executed north of the Tweed, especially in later times, some of which recalled the Late Gothic tracery at the Church of St. Eustace at Paris. Attention had not been called to the beautiful example of groined work to be seen at Dunfermline Abbey.

Mr. R. PHENE SPIERS, F.S.A., seconded the vote of thanks, observing that Scottish archi-

ecture was obviously original, and neither copied from English or French work. At Melrose Abbey the great beauty of the decorative carving was very noticeable. There seemed to be some foreign influence apparent in Roslin Chapel—either Spanish or Portuguese—but after carefully studying that building, which displayed an extraordinary originality and power, he had returned puzzled and dissatisfied with his analysis.

The motion was supported by Mr. HENRY LOVEGROVE and Mr. BERESFORD PITE, the latter remarking that Mr. Blanc, in his criticism of the restoration of St. Giles's, Edinburgh, had lighted the funeral pyre of Mr. Burn; but from that office had come Norman Shaw and MacVicar Anderson. There was an obvious want of coherence in Scottish design throughout the Gothic period, and it was very doubtful whether the fenestration was derived from Norman or Spanish sources. He wondered where the idea of the Scottish crown spires was derived from, as it seemed altogether foreign to the spirit of the period, and country. There was an absence of finish in the carving; but this possibly might be due to the use of hard, coarse, and intractable stone. And when they recollected the eternal lack of pence and the hard times occasioned by the English, they must admit that the old Scottish designers did wonders.

Mr. THOMAS ARNOLD said any foreign influence in Early Scottish architecture must have been French, and not English, as the Scotch were constantly at war with the Norman conquerors of England. He had never heard so lucid and interesting an account of the Later Scottish architecture.

The vote of thanks having been passed by acclamation, on the motion of the President, who observed that Roslin was still a puzzle, Mr. BLANC responded, remarking that he had taken some 500 photographs of Scottish churches, of which he had brought to London over 200 lantern slides, and he had spent the whole of that day in weeding these down to the absolutely essential 70 views to explain his subject. The influence of Scottish work on English architecture had been as potent as that of English work on Scotland. Even the crudest work of Scotland had, he claimed, a touch of the refinement, and even of poetry, which was well known to belong to the nation. He suggested that the Architectural Association should endeavour to arrange an excursion to Scotland, in conjunction with the kindred body at Edinburgh. He could promise them a hearty welcome, and the visit would be a mutual benefit, he believed, to the members of both Associations.

#### "THE BASIS OF DESIGN," BY WALTER CRANE.

THE last addition to the artistic library which Messrs. George Bell and Sons have produced is a handsome volume of lectures by Mr. Walter Crane on "The Basis of Design,"\* in which he endeavours, with no little success, to build up his thesis from the architectural root through "utility" and "material," which in turn are, of course, influenced by climatic and racial conditions, and find expression ultimately through such controlling limitations as "the symbolic," "the graphic," "the individual," and "the collective" impressions. One scarcely knows which to admire most in the character of Mr. Walter Crane, his wonderful facility of inventiveness in the patterning and scheming of decorative design, or his remarkable and sustained industry. Throughout, his work is undoubtedly mannered, and sometimes this mannerism seems detrimentally to dominate his productions in a regrettable way; but possibly this is inevitable in any case, and particularly where the producer evolves so much as Mr. Walter Crane, who has so masterful an individuality. His influence, therefore, as a teacher, cannot be confined to the comparatively limited sphere of the Manchester School of Art, where these lectures were originally delivered during the Directorship of Design held by him at that institution with so much *éclat*. Of these essays he says: "My main object has been to trace the vital veins and nerves of relationship in the arts of design, which, like the sap from the central stem, springing from connected and collective roots out of a common ground, sustain and unite in one organic whole the living tree." Thus the author's scheme is far-reaching enough for any man; indeed, he admits that every chapter

\* The Basis of Design. By WALTER CRANE. London: George Bell and Sons, Covent Garden. 1898. 18s. nett.



FIG. 1.



FIG. 2.



FIG. 6.



FIG. 5.



FIG. 3.

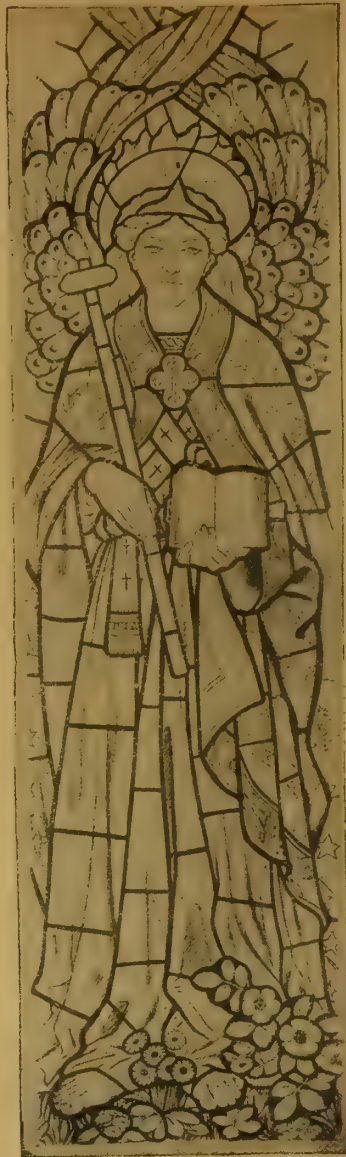

FIG. 4.

of his book might be expanded into a volume to secure for each section anything like an adequate treatment. But, after all, it is the suggestiveness of his writings which constitutes their value, giving enough, even where the touches on some branches of his subject are necessarily elementary, to set the student thinking, as he is started off in a right direction to work out for himself some of the problems connected with the art with which he has set himself the task of becoming acquainted, if not, in fact, to master. Mr. Crane begins at the beginning, and at the outset declares that the original and controlling fundamental principle of design is to be found "in Architecture, the Queen and Mother of all Arts," and so we are taken through the familiar development of architectural form and construction, the architecture of the round arch or dome, and the architecture of the pointed vault and buttress. The theme, of course, is not new—how could it be? but it is handled in an individual way, and that is what one wants, for, though Mr. Crane's method is by no means the strictly architectural way of treating the matter, the decorative side of the subject is never divorced unduly from the constructive. On the contrary, Mr. Crane insists again and again on the necessities of construction being utilised as the true base of a decorative feature and significant of its design. The construction, too, of decorative ornament, showing the relation and proportions of the masses in relief to the ground, is enlarged upon, as, for example, in the spacing of a metope of the Parthenon, which is treated upon in particular. The value of simplicity of line, the value of recurring and re-echoing forms, the value of figures in low relief, and the value of largeness of style in design are each in turn found emphasised in the first instance by the architecture of the Lintel, and in the Parthenon especially. As a

matter of fact, however, throughout the history of the art the same lessons are to be found in the acknowledged types of the various styles, and even in the degraded periods, because as architecture deteriorated, it is manifest to even the casual observer that these values, of which we have spoken, are made conspicuous by their absence.

Mr. Crane, having taken his pupils through the styles in this manner, draws their attention to minor details, and directs their notice to furniture and articles of utility. Then the influence of material and method. This, by way of example, is illustrated through a study of wrought-iron work, as showing what ornamental effects can be gained by economy of means, the effectiveness of simply repeating well chosen curves, spirals, and lines, the whole being governed by the controlling spirit and period of the architecture of which it becomes a part. The flowing Renaissance scroll balustrade from Rothenburg, herewith illustrated, from a drawing by Mr. Phené Spiers, is a case in point, Fig. 1. Compare this with the altar screen from St. Thomas Church, Salisbury, Fig. 2. On glass design Mr. Crane has many useful things to say, and he gives several good illustrations. We are enabled to reproduce two, showing lead lines as the governing element, from cartoons by the late Ford Madox Brown, Figs. 3 and 4, which are in every way admirable.

The climatic influence and the essential difference of character as between the products of one country and another, are fittingly referred to. We associate, naturally, brilliant colours and bold designs with Eastern and Southern countries; but apart from the great stimulus of light which might encourage the use of vivid colour, broad and full sunlight has a curiously flattening effect upon colour and pattern, and, therefore, colours and patterns which, under a grey sky, would look staring or very strong and striking, under the

sunlight fall into place and become subordinated to the dominant pitch of light. The porch of the cathedral at Pistoia, with its bold black and white bands of marble which face the front of this building, is given as an illustration which demonstrates this fact, Fig. 5.

Of such indications of character and preferences generally traceable to the race, or mixture of the races from which a people have sprung, Mr. Walter Crane has much that is useful to say. We attribute certain imaginative faculties to our Celtic origin; certain calculating and analytical capacities belong to Teutonic sources; while a mixed race, such as the Anglo-Saxon, is presumably distinguished by a marked practicality. These typical racial characteristics impress the art of a people, giving preference in colour, form, pattern, treatment, sentiment—and idea, leaving a distinguishing mark upon the history of art, eloquent of the life of a nation, records of powers possibly long ago covered by the sands of time. It is difficult to disentangle these strictly racial characteristics entirely from other influences. Climate, habit, and local materials all help in its formation, yet a purely human element none the less real is discoverable, as clearly definable very often as the stamp of individual choice, as well as of the collective sentiment and climatic influence. The Egyptian hieroglyphics, their lotus flower; the ram and sun symbolising Amru-Ra, the king of all gods, the Assyrian trees and other forms are all distinctly definable, though the same ideas, and sometimes the same forms, reappear in Persian, Greek, Roman, and Renaissance work. The Assyrian Tree of Life (Fig. 6) became with them a formal piece of ornament constantly recurring in the art of all the Asiatic races, and was carried by them apparently, or from them, into Europe. So with other Early forms and ideas—they, too, often originating in a common source, gradually changed and became modified, as our author has in the volume before us in general terms skilfully indicated. For his chapter on Symbolism in Art and his account of Graphic Art we must refer the reader to these lectures themselves. They conclude, as we have already indicated, by some clever remarks upon Individual Influence and on Collectivism in Art, the collective experience of ages. And thus the book ends: "If we realise the close and necessary links that unite all workers, that are essential to the production of things useful or beautiful, or both, should we not do well to strive to make the association closer and more complete than it is, and thus hand on the lamp of good tradition in design and workmanship, however far we must look forward to the enlargement of our horizon and the harmonising of human life, and its freedom from the sinister powers and false ideals that now oppress and deceive it. And if we may accept the truth that art is unity, and that what the unit is the mass may become, should we not strive, each in his sphere, whatever our main work may be, to do it worthily and well? remembering that it is better to do a small thing well than a big thing badly, and that it is the spirit in which our work is done, not the place it may accidentally occupy, or the class to which it may belong, or the reward it may receive in the ordinary estimation, that makes it great or little." There is no more to be said; the author shall thus have the last word. His book is well got up and nicely printed. The drawings are not uniformly equal in merit; lecture cartoons do not always make best book illustrations. The delineations of Gothic ornament are not among the most successful in the series, though they serve their purpose.

A sculptured monument has been erected in the south aisle of St. Michael's Church, Beer, South Devon, in memory of the late Miss Isabella Agnes Byles, of Whitecliff Glen. It has been executed in the studios of Messrs. Harry Hems and Sons, of Exeter, who carried out the whole of the carving and sculpture in the same church during the restoration, some 20 years ago.

At the meeting of the Monmouth Town Council held last week, a lengthy discussion took place regarding the cost of the new drainage scheme now being carried out by Messrs. Johnson Brothers. The original estimate by the engineer, Mr. Lailey, was about £12,000, and the original contract was £8,005. A report from Mr. Lailey before the board now estimated that it would take £16,432 to complete the work. The question of borrowing £10,000 more was adjourned, and it was decided to hold a special meeting on the 23rd inst., and invite Mr. Lailey to attend and explain.



CONTENTS.

Institute of Painters in Water Colours ... ..	367
Model Specifications.—IV. ....	368
Sanitary Work.—I. ....	370
Architectural Association ... ..	372
"The Basis of Design," by Walter Crane ... ..	374
THE BUILDING NEWS DIRECTORY ... ..	xi.
Our Illustrations ... ..	377
Competitions ... ..	377
BUILDING NEWS DESIGNING CLUB ... ..	396
The Brook Hospital ... ..	396
Obituary ... ..	396
Professional and Trade Societies ... ..	397
Building Intelligence ... ..	397
Intercommunication ... ..	398
Legal Intelligence ... ..	398
Water Supply and Sanitary Matters ... ..	399
Parliamentary Notes ... ..	399
Our Office Table ... ..	399
Meetings for the Ensuing Week ... ..	400
Trade News ... ..	400
Latest Prices ... ..	400
List of Competitions Open ... ..	401
List of Tenders Open ... ..	401
Tenders ... ..	404

ILLUSTRATIONS.

ANGELS AT THE VATICAN, BY MICHAEL ANGELO.—NEW POST OFFICE, SUBERTON.—"THE PARADE," BOSCOMBE.—DESIGN FOR A SCREEN FOR A PRIVATE CHAPEL.—DESIGNS FOR VILLAGE, HAMLET, AND MOUNTAIN CHURCHES.—A SOMERSETSHIRE FONT AND PULPIT.

Our Illustrations.

FIGURES OF ANGELS FROM THE VATICAN, BY MICHAEL ANGELO.

THE angels of Michael Angelo are almost, without exception, wingless beings endowed with superhuman forms, striking in the boldness of their muscular attitudes, depending on vigour rather than aiming at an ideal angelic conception of the messengers of the Most High. Nevertheless they exemplify great imaginative and artistic power exhibited in the realisation of the grandness of form, though the tranquillity, serenity, beatitude, ethereal purity, and spiritual grace may be sought in vain in these masterpieces of Titanic art. The "Angel in the Annunciation," by Michael Angelo, is, perhaps, his single exception in the employment of wings. The followers of his school in its later phases degraded this earthly form of spiritual beings adopted by their great master, and they caricatured his ideals, rendering them at times extravagant and even sensual. Raffaele stands alone in his sense of the aerial character of angels, though Rembrandt's works in this respect are of the highest degree of merit. Titian's angels are limited by a sense of glorified infancy. Correggio's angels are grand and lovely, while, elegant as the angels of Leonardo da Vinci unquestionably are, they seem to smile too much, and so fail in force of power, seldom entirely realising that knowledge of strength peculiar to the sons of God shouting for joy. As decorative groups, those which we reproduce to-day are too well known to need description. They embody this master's strongest characteristics in the sense which we have briefly indicated.

SUBERTON POST OFFICE.

THIS new Government building is fully illustrated by the accompanying plans and view, so as to need very little description. It is being built in red brick, with Bath stone dressings. The builder is Mr. G. H. Tucker, Caversham-road, Reading, and the architect is Mr. E. G. Rivers, of H.M. Office of Works.

"THE PARADE," BOSCOMBE.

THIS row of business premises, illustrated by the accompanying photograph, may be named among the extremely few buildings at Bournemouth which have any real architectural fitness or merit. Boscombe particularly is devoid of any buildings worthy of such a description. Mr. T. E. Collutt's big hotel is, of course, a conspicuous exception, and in Bournemouth proper Street's grand Church of St. Peter gives the town a real character. Sedding's church, and another by Mr. Norman Shaw, help to redeem the monotony of the place, which, for the vulgar

pretentiousness of its buildings, is scarcely surpassed, particularly some of the Nonconformist buildings in the town, on which no money seems to have been spared. "The Parade," Boscombe, has been built from the designs of Mr. Norman Wight, architect.

DESIGN FOR A SCREEN IN A PRIVATE CHAPEL.

THERE is a degree of freshness and richness of treatment in the accompanying Silver Medal design for a screen by Mr. James B. Fulton, which may be considered suggestive. The original drawing was washed over with a pale tint, which rendered its reproduction somewhat difficult, to the loss of some of its detail. It was crisply drawn, and the sculptures along the frieze were enlivened with gold and colour. The idea of the designer has been to adapt Late Perpendicular forms to modern uses.

"BUILDING NEWS" DESIGNING CLUB: A SMALL SUBURBAN CHURCH.

(FOR DESCRIPTION AND AWARDS SEE P. 396.)

A SOMERSETSHIRE FONT AND PULPIT.

THE font, with its handsomely carved cover, is taken from Banwell Church, and is interesting, exhibiting, as it does, on the bowl, the use of seaweed as a means of ornamentation. The cover is of oak, octagonal in plan, terminating in a spire, with metal ring attached. Besides the font, there is a very richly carved and gilded rood-screen between the nave and chancel, the church itself being a good example of the characteristic Somersetshire Perpendicular type. The pulpit, which is from Huntspill Church, presents a sturdy and massive appearance, being of oak and decagonal in plan, three sides being omitted at the back to form the entrance. It will be noticed that each face, though of similar form, is differently treated as regards the carving, thus forming a rich variety. The letters forming the texts are left slightly projecting, the surrounding wood-work being picked out. The church itself has a lofty and spacious interior, and was partially destroyed by fire some years ago, but has since been restored. E. RODWAY.

IT was reported to the Heywood Corporation at their last meeting that about half of the work in connection with the strengthening of the embankment of the higher reservoir in the Nayden Valley had been completed, and the cost up to date had been £6,080, exclusive of £4,003 for plant and material.

A new fire-brigade station has just been built at Hampton, Middlesex, by the urban district council. The architect is Mr. J. Kemp, A.M.I.C.E., the surveyor to the council. The building is in red brick, with Mansfield stone dressings, with elliptical arches and gables, and was erected by Messrs. Wright and Son, of Hampton.

Mr. G. W. Willcocks, M.Inst.C.E., Local Government Board inspector, held an inquiry at the town-hall, Maidstone, recently, with reference to the application of the corporation for sanction to borrow £1,023 for the construction of a new street and for street improvement.

Colonel W. R. Slacke held a Local Government Board inquiry at the town-hall, West Bromwich, last week, concerning the application of the town council for sanction to apply £3,500 of the balance of loan raised by them for works of sewerage and sewage disposal in defraying the cost of works of sewage disposal.

A new bank has just been built for Messrs. Stuckay in Regent-street, Kingswood, near Bristol. Messrs. Crisp and Oatley, of Clare-street, Bristol, are the architects, and Messrs. W. Cowlin and Son, of the same city, are the builders. The front is of Ham Hill stone.

Mr. H. H. Law, one of her Majesty's Local Government Board inspectors, held an inquiry at the Oswald Lodge, Woolston, near Southampton, on the 10th inst., into the subject matter of a petition to issue a provisional order to empower the rural district council of South Stoneham to put in force with reference to lands required by them for the disposal of the sewage of the parishes of St. Mary Extra, Sholing, and Bitterne, the powers of the Land Clauses Acts with respect to the purchase and taking of lands otherwise than by agreement.

Two new underground conveniences and lavatories have just been completed for the Shoreditch Vestry, the one in the High-street, and the other in New North-road. These conveniences are for both sexes, and have been constructed for the vestry, at a total cost of about £4,100, by Mr. George Jennings, sanitary engineer, of Lambeth, under the direction of the Works Committee and the surveyor, Mr. J. R. Dixon, A.M.I.C.E.

COMPETITIONS.

BARROW MUNICIPAL TECHNICAL AND ART INSTITUTE.—Acting on the advice of the assessor, Mr. Henry Lord, of Manchester, the committee of the Institute have awarded the first premium of £50 to the design submitted by Messrs. Woodhouse and Willoughby, of Manchester, and the second premium of £20 to Messrs. Wood and Hutchings, of Tunstall. The estimated cost of the structure is about £9,000.

CHIPS.

On Friday, the Woodnow district of Farsley, which has suffered for years in consequence of an insufficient supply of water, was coupled with the high-level service of the Bradford Corporation, who have carried out the work.

The partnership hitherto subsisting between L. A. Withall and E. H. Barton, architects and surveyors, Jewry House, Old Jewry, E.C., under the style of Latham A. Withall, has been dissolved.

In the House of Commons yesterday (Thursday) afternoon a Bill was introduced to enable the Government to commence building operations on the sites now being cleared in the vicinity of Whitehall and Parliament-street.

The ceremony of cutting the first sod of a new dock which is to be constructed at Llanely is to be performed on Tuesday. The dock, which is to be nine acres in area, will be 1,000ft. long and 400ft. wide, with quayside of 1,200ft. It will be 17ft. deep on the sill, and the gates will be 50ft. wide. The total cost will be nearly £200,000.

At the Congregational Chapel, Highgate, N., an alabaster cenotaph with panel of white marble has been erected as a memorial of the late Rev. Josiah Viney, 1816-96. Above the panel rises a massive canopy, crocketed, terminating in a crisply carved finial. The memorial has been carried out by Messrs. Harry Hems and Sons, of Exeter, from designs by Mr. E. J. Paine, F.S.I., architect.

The Bill for incorporating the Brighton Underground Railway Company was to have been considered on Tuesday by a Select Committee of the House of Lords. At the meeting of the committee, it was announced that the promoters had decided to withdraw this scheme, which provided for the construction of an underground railway from Brighton railway station to the sea beach.

At the church of the Holy Innocents, Fallowfield, Manchester, on Sunday, the dedication of the Jubilee thank-offering took place. This thank-offering consists of a set of nine canopied stalls occupying the full width of the nave at the west end. In the back of each stall is a medallion carved in oak. The centre one contains the symbol of the Holy Innocents; the other eight the symbols of the Beatitudes.

The annual report of John Bazley White and Brothers (Limited) states that 1897 has been a year of improvement in the cement trade, both as regards prices and demand. The increase in the profits is due to decreased cost of manufacture and increased prices of sale. The amount of £89,057 is after deduction of £35,372, which sum includes all ordinary repairs and replacements, as well as the special outlay to repair the damage caused by the recent floods. After the deduction of debenture and mortgage interest, sinking fund, and dividend paid on the preference shares, there remains a balance of £47,973, out of which it is proposed to pay 4 per cent. on the ordinary share capital, to place £10,000 to reserve, and to carry forward £1,118.

By a disastrous fire, which occurred in November, 1896, the Valletort flour mills and warehouses at Plymouth, belonging to Messrs. Hosken, Trevithick, Polkinhorn, and Co., Limited, were entirely destroyed. Preparations were immediately made for rebuilding, and Messrs. Lethbridge and Sons, of Plymouth, were intrusted with the contract. The order for the machinery was placed with Messrs. Henry Simon and Co., Limited, of Manchester, milling engineers. Not only is the new building a larger structure, but its milling capacity is considerably greater.

Mr. J. S. Brodie, C.E., the engineer to the Whitehaven Harbour Commissioners, has reported to that body on the alterations necessary for the accommodation of the proposed daily service of steamers between Whitehaven and Ramsey. Mr. Brodie has prepared alternative plans for adopting either the north pier or the west pier as low-water landing berths. He estimates the provision of a north pier berth and dredging at £6,057 18s., north pier extensions at £8,178, and contingencies £738 2s., or a total of £15,514. The alternative scheme is, west pier berth and dredging, £3,345; north pier extension, £8,718; contingencies, £603; total, £12,666. Mr. Brodie strongly recommends the north pier scheme, and especially the extension of the north pier itself, which was part of the original scheme of Sir John Rennie.

SOMERSETSHIRE FONT

AND PULPIT



FONT BANWELL

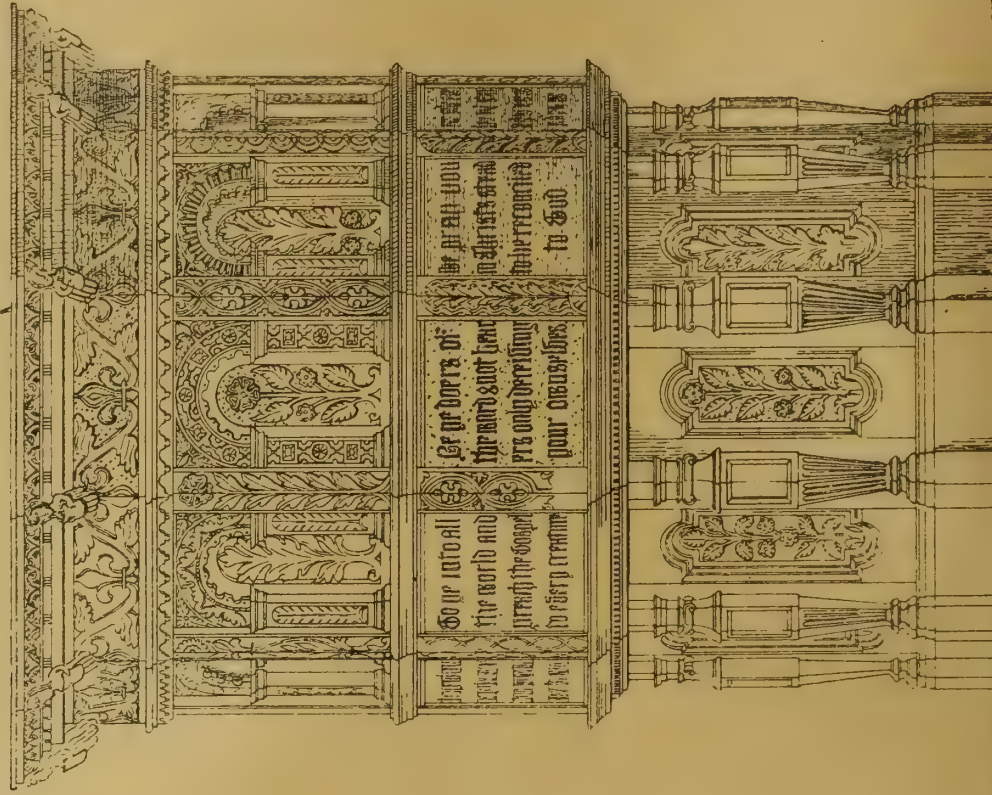

PULPIT HYNTPILL

Scale 1/4 inch = 1 foot

Printed and Published by  
 the Proprietors, 11, Abchurch Lane, London, E.C. 4.





FIGURES OF ANGELS AT THE VA

MAR. 18, 1898.



"PHOTO-TINT" by James Akerman, 1, Queen Square London W.C.

SCULPTURE BY MICHAEL-ANGELO





— NEW POST OFFICE —  
— SURBITON —  
*E. G. RIVERS, ARCHT.*

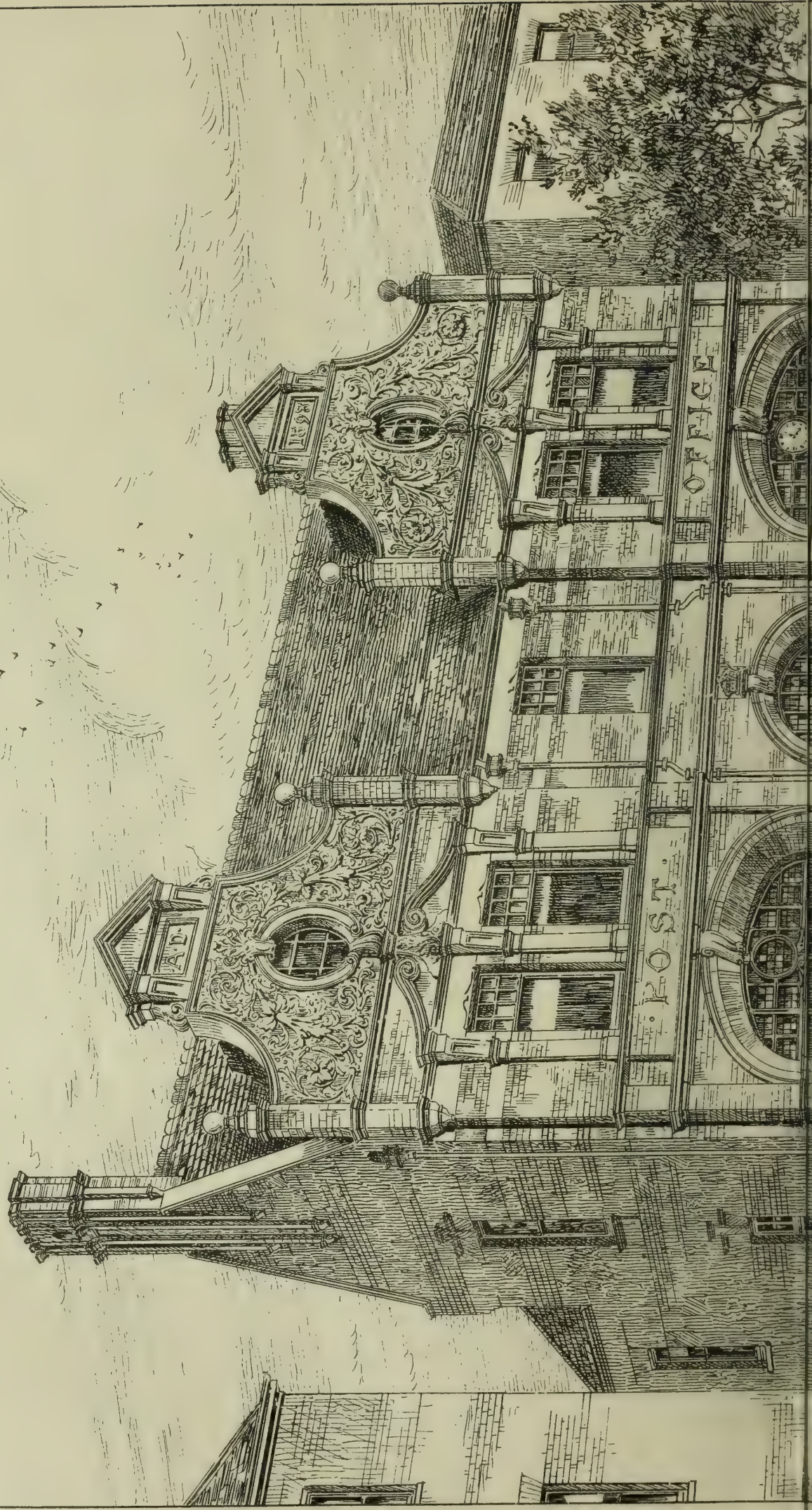





A Bickerdike. Det.

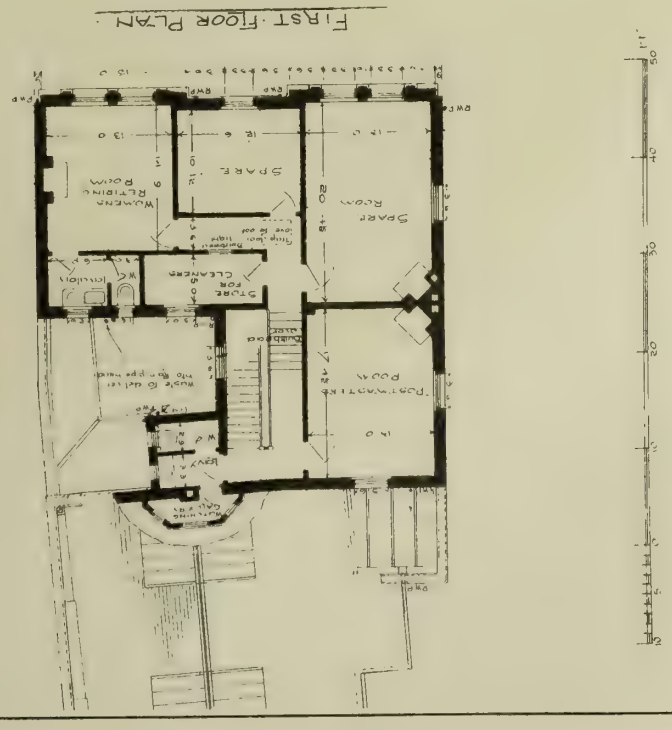
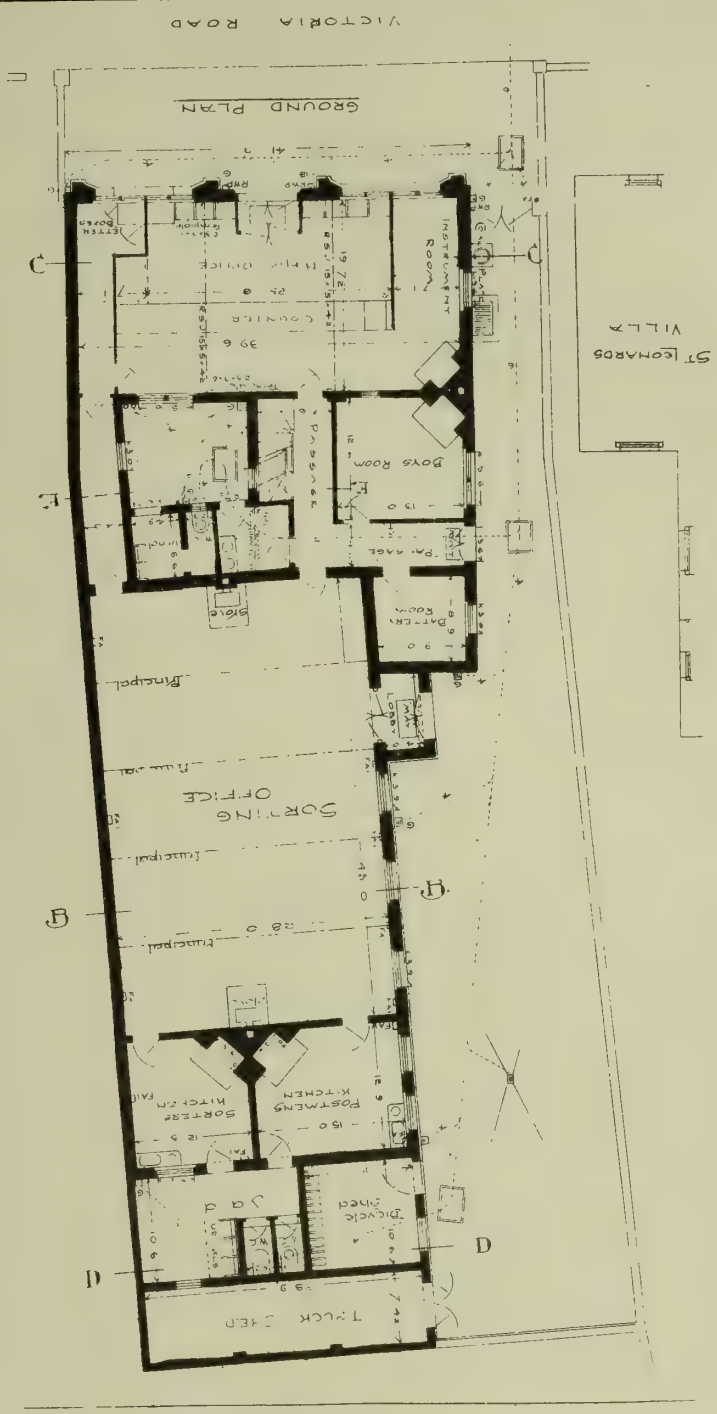





A VILLAGE CHURCH,  
BY "CENTAUR."

B·N·D·C·

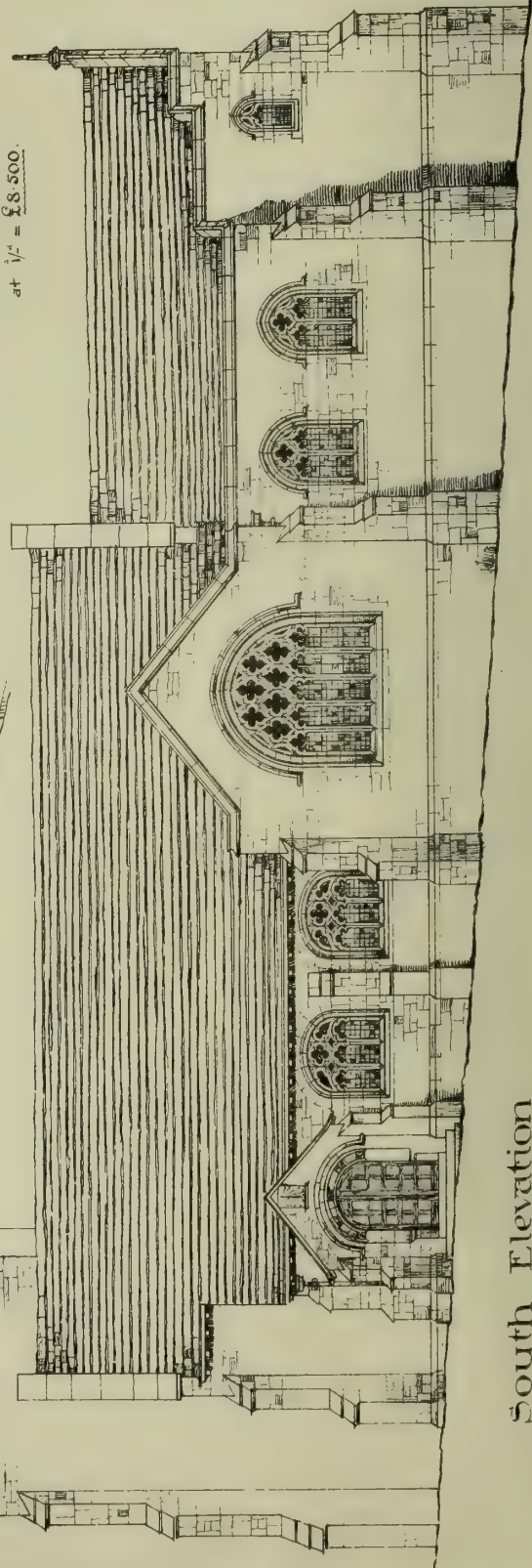
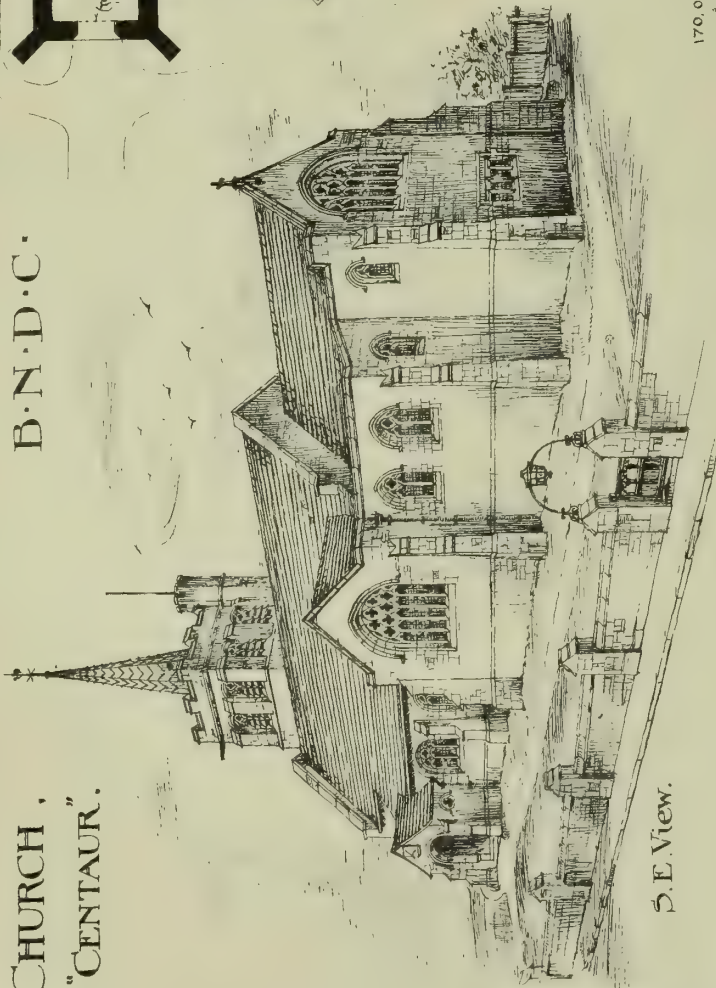
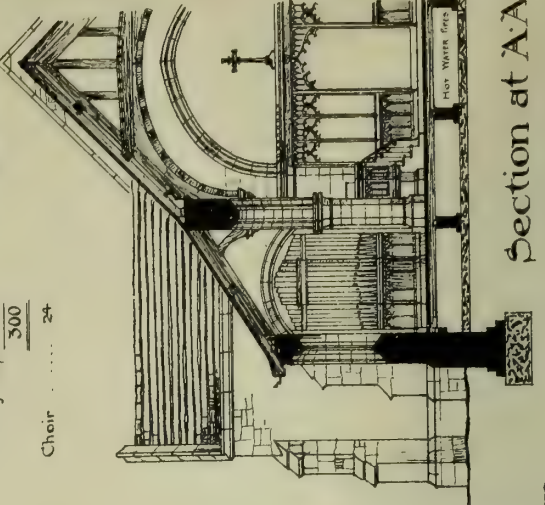
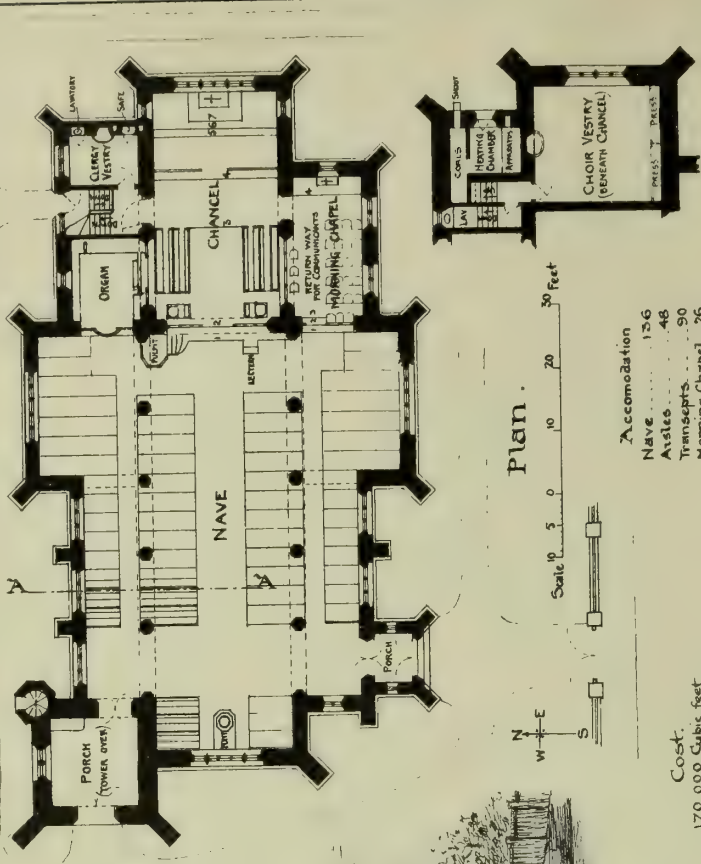

Accommodation

Nave	126
Aisles	48
Transsepts	90
Morning Chapel	26
<b>Total</b>	<b>300</b>

Choir ..... 24

Cost.  
170,000 Cubic feet  
at 1/2" = £8,500.

PLACED FIRST

Scale of 0 5 10 20 30 40 50 Feet.

Feb/98.



PL.

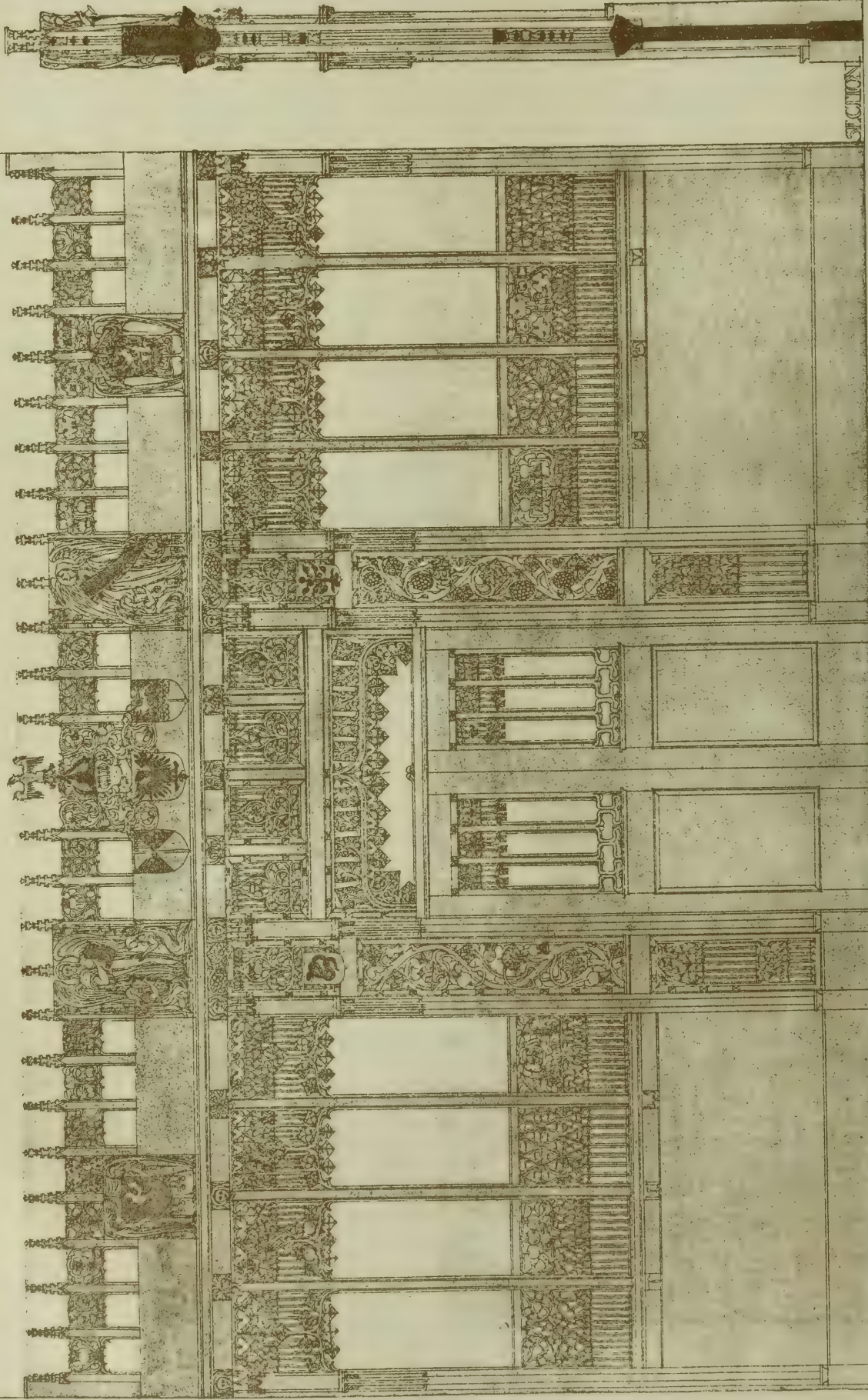

ELEVATION.



PLAN.

DESIGN FOR A  
SCREEN IN A  
PRIVATE CHAPEL

DESIGN FOR A SCREEN IN A PRIVATE CHAPEL. NATIONAL SILVER MEDAL AWARDED. JAS B FULTON

PHOTO-TINT, BY James Akerman & Co., Queen's Square, London, W.

THE BUILDING BEGINS, MAR. 18, 1898.

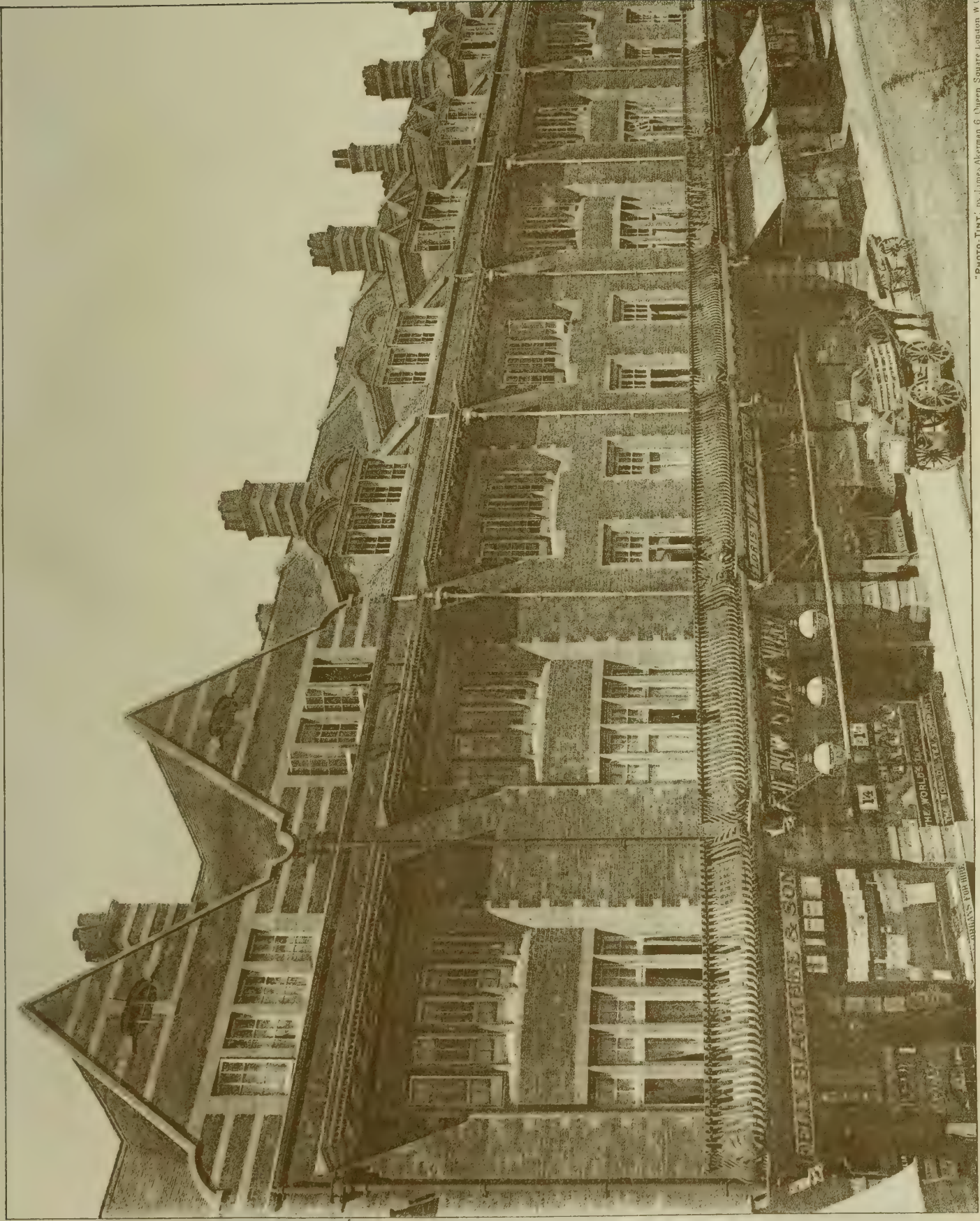

PHOTO-TINT. by James Akerman 6 Queen Square London W.C.

THE PARADE BOSCOMBE HANTS · NORMAN WIGHT ARCHT





PLACED SECOND

B.N.D.C.

DESIGN FOR A HAMLET CHURCH

By "BYD"

SCALE OF FEET FOR ELEVATIONS  
SCALE OF FEET FOR PLANS

Cubical Contents = 130468 cu ft.  
of ft.

Accommodation:  
Nave and Transept . . . 302  
Chancel . . . 26

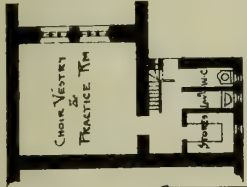
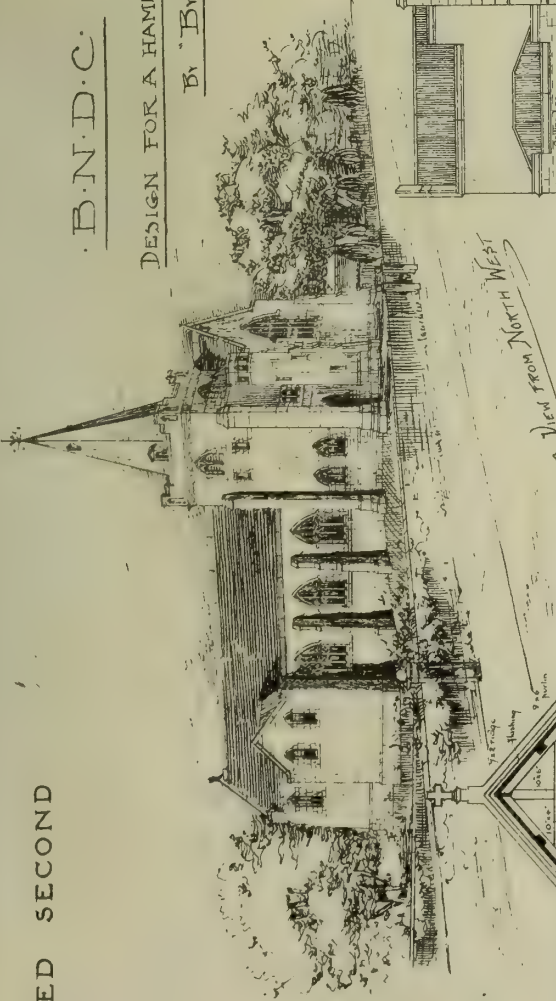

PLAN OF VESTRIES

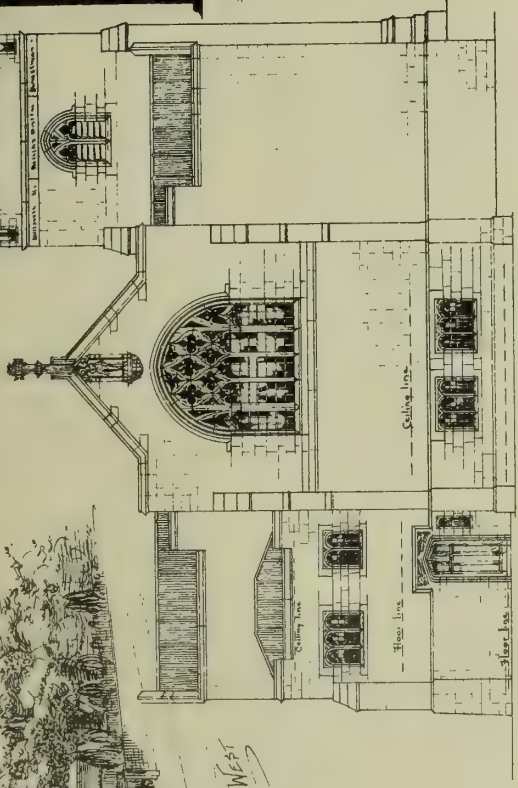

EAST ELEVATION

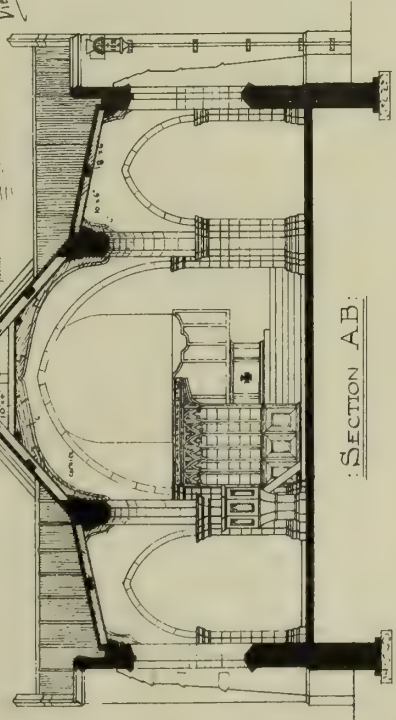

SECTION A-B

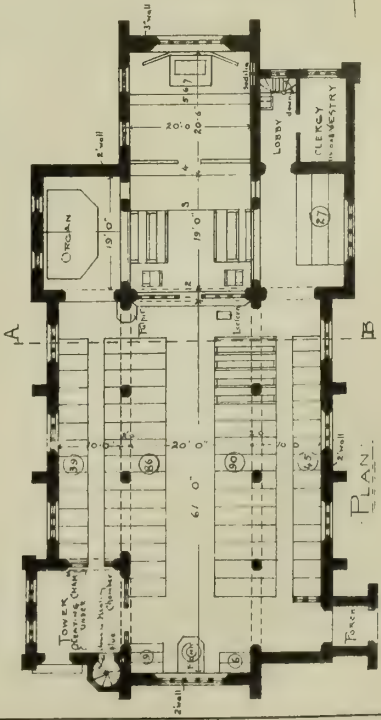

PLAN

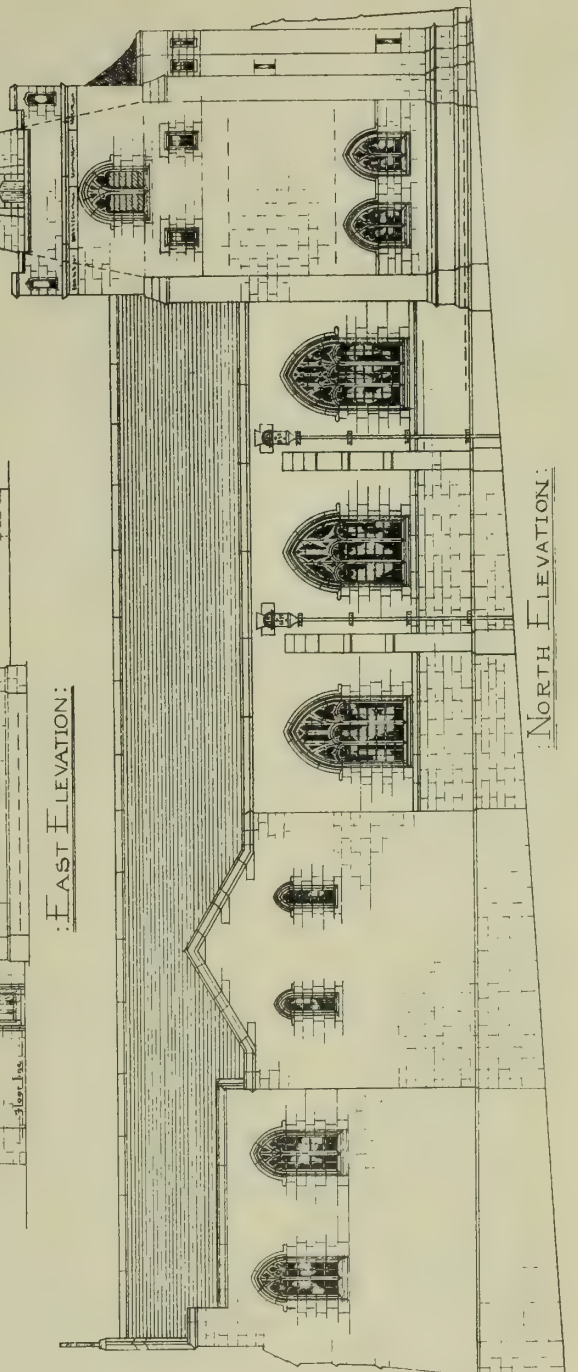

NORTH ELEVATION



PLACED THIRD

B.N.D.C. DESIGN for a  
MOUNTAIN CHURCH  
COST £7,000 by PANTILE.

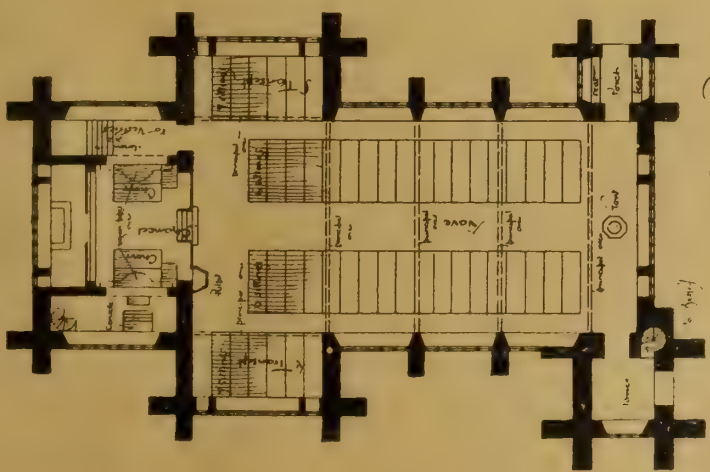

Ground Plan



Vertical Plan

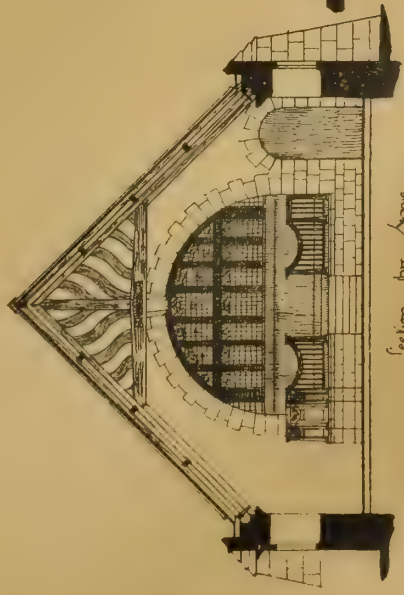
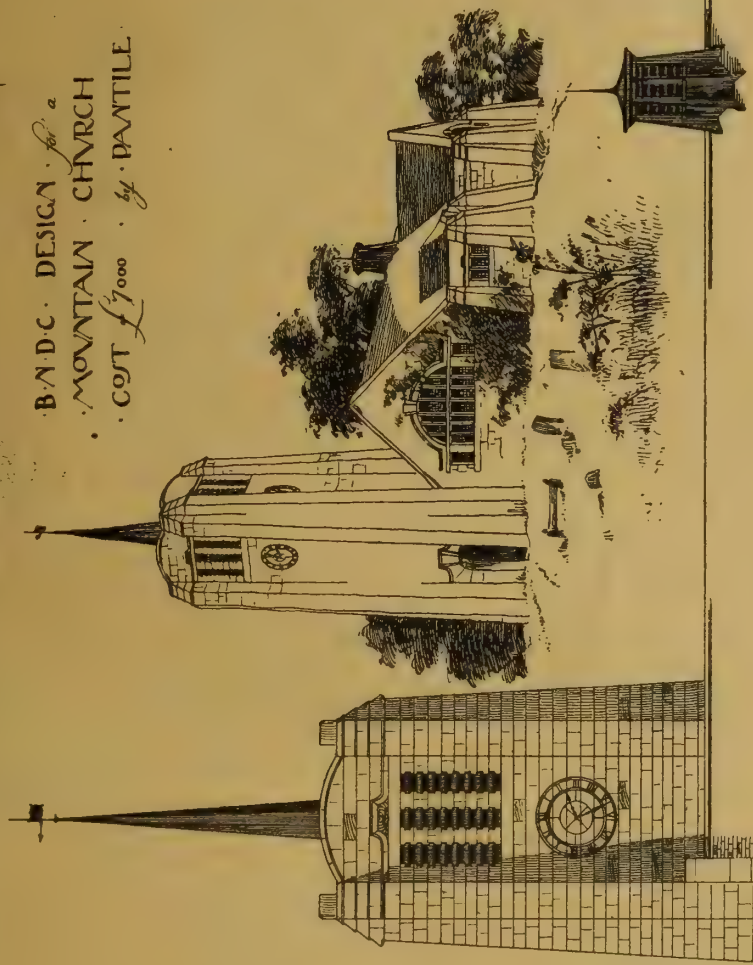

Section through Nave

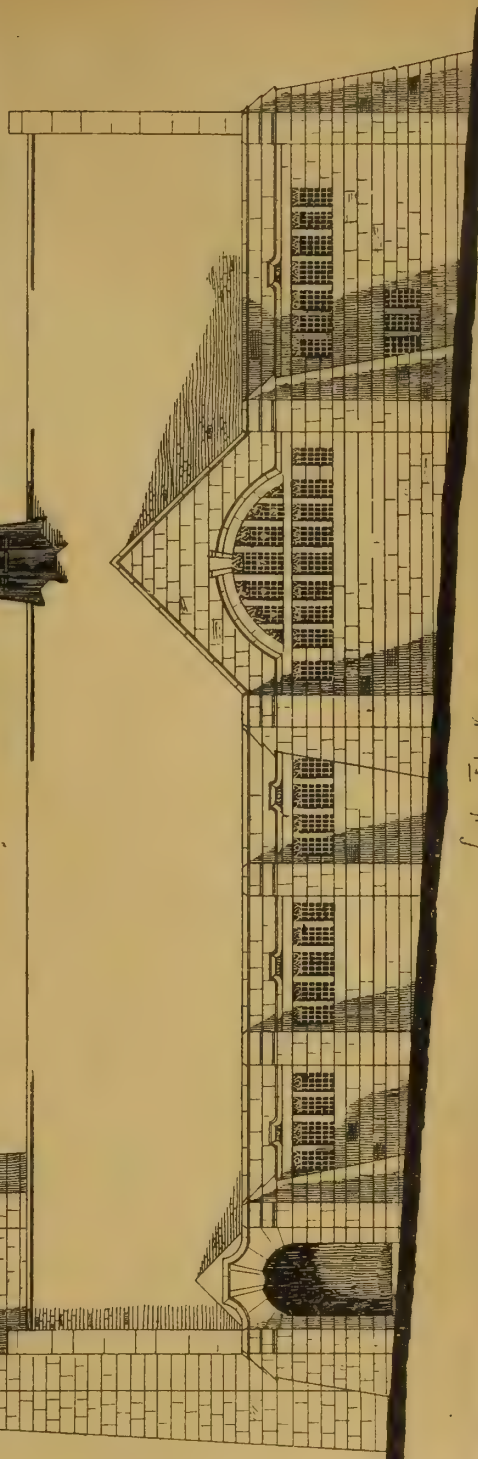

South Elevation

West Elevation

## "BUILDING NEWS" DESIGNING CLUB.

A SMALL SUBURBAN CHURCH.

A SMALL church for a hamlet on the outskirts of a town. The building to accommodate 300 and a choir of 24 voices. The site falls from W. to E. 10ft., and it is situated at the corner of two roads, with a south frontage of 160ft., and a depth of 100ft. to the second road, which runs N. There is to be a spire at the N.W. corner of the building, and the west entrance is to be through this tower, which will form a porch. There is also to be a south porch, and there may be transepts; but the building is not to be ornate, and it must be adapted to church requirements, and have a choir-vestry, as well as one for the priest. These need not be level with the church. The altar pace is to be seven steps above the nave floor, and the central passage-way up the nave is to be 8ft. wide. The organ must be near the chancel, and not be cramped in a recessed "organ-chamber," so as to impede the sound of the instrument gaining full vent. Material, coursed stone and wrought dressings. Style left to competitors. Roofs open-timbered, and covered with tiles. A pulpit and screen to choir to be shown. Scale, 8ft. to the inch for one main elevation and cross-section; other drawings may be 16ft. to the inch. Sketch view desirable. Cost will be taken into consideration; but no precise sum is fixed, though an estimate reckoned at a shilling per foot cube is to be furnished with each design.

These are the conditions which set out our requirements, and the two accompanying photolithographic drawings illustrate how our suggestions have been realised by the two architects whose plans were chosen for the first and second places. A block illustration of the third design is given with our letterpress. The first is by "Centaur," the second is by "Byd," and the third is by "Pantile." The last named is the most original; but we do not think his design is either attractive or suitable—in fact, it is crude and does not realise church requirements. "Centaur" works on regulation lines, though a strict ecclesiologist would not put a choir vestry under the sanctuary. The plan presents nothing very novel, and the external treatment hardly calls for much comment. There is good taste observable in the broad wall spaces and dignified simplicity of the elevations. "Byd," in a way, is rather similar, the transepts being, however made part of the choir rather than adjuncts to the nave. The interior we like better—indeed, the choice between these two is not very great, and not exactly easy to define. Some would no doubt prefer one to the other. The governing feeling in favour of the scheme placed first is that it is more like a village church in general idea, and it seems better as a whole. We have, perhaps, said enough about "Pantile's" design, which is rather American in type—at any rate, it is un-English. That is not a fatal fault; it is not enough, however, to be uncouth and queer, though we recognise the author's endeavour to give something out of the well-worn track. The course he has adopted, be it noted, would soon wear itself out, and this church, if built, would not weather well. Its regular coursed masonry is very out of keeping with the design. "Dacho" (who sends neither name nor address) comes next, chiefly on account of his elevation, for the plan is poor enough, with a heating chamber—of all things in the world—under the altar pace. The treatment externally is free, and the square-headed clerestory windows are ugly. "Thrams" is simple and is marked by a regulation air, with a squat Sussex-like tower, the walls of which are very thin. His tracery is Flamboyant, but weak. "Petticoats" does not understand church work, and his chancel is shockingly contrived. The view being somewhat spiritedly drawn attracts attention; but the whole thing is unreal and unsuitable. "Microbe" is very weak in a bold Lancet style which hardly calls for further comment. "Checkmate" conceives a hamlet church to look as if it were intended for St. John's Wood. He makes a feature of the narthex, or, in common English, the passage-way between two doorways, and here he locates the font. A nice draughty place for infants surely, particularly those who are baptised, in accordance with the Rubric, within eight days of their birth. This would be "Checkmate" with a vengeance. "Phantom" seems to believe in sloping buttresses, one of which he uses to shore up the relieving arch of his transept. His tower is very ugly. We really cannot specify all these

designs; they are so poor. The church work of the future will be in a sorry way if the coming generation of architects cannot do better than these designs. They come as follows:—"Stone," "Tee-Square," "Olliwops" (no name or address), "Chuckle," "Hotspur," "Lany," "Gossip," "Derige," "Stanley," "Spark," "Gaiour" (sic), "Pick-Me-Up," "Bantam," "Eric," "Cobden," "Gib," "Hubert," "Oak," "Strax," "Tit-Bits," "R. W. P.," "Bernard," "E. G." "William the Englishman," and "Chess."

## THE BROOK HOSPITAL.

AT Friday's meeting of the Metropolitan Asylums Board, an adjourned discussion took place on the report of the special committee in the matter of the Brook Hospital expenditure, which had exceeded the estimate by about £50,000. The committee had recommended the payment of the contractors' claims as finally adjusted by the architect, Mr. T. W. Aldwinckle, and the renewal of an application to the Local Government Board for an order authorising the further expenditure on loan, in respect of the erection and equipment of the hospital, of the sum of £100,000 in lieu of the sum of £75,000 applied for on Oct. 10, 1896. To this Mr. J. H. Brass had moved, as an amendment, "That the report be referred back to the committee for them to report as to the cause of the extra expenditure, as to the several contractors not executing the works in accordance with the sealed contracts, as to the power of the architect to order additional work without the authority of the board, and as to whether the certificates of the architect for such works are or are not *ultra vires*." Mr. Lile, in resuming the debate, attributed blame to the committee in allowing the architect to incur an extra expenditure of nearly £39,000 without reference to the committee; but did not think there was any evidence to show that if the whole of the items of extra expenditure had been brought before the committee the expense could have been in any way reduced.

Several members agreed that the board had a substantial building which was worth every shilling which had been spent upon it.

Mr. Purchase said the disclosures which had been made in connection with this matter were a gross scandal.

Mr. T. J. Robins asserted that the Brook Hospital Committee was as much to blame as the architect.

Mr. Edward White, the chairman of the committee of inquiry, expressed the opinion that the architect was largely to blame in not consulting the committee as to the extra expenditure.

The amendment was lost by 44 votes to five, and the recommendations of the committee were agreed to.

Mr. Lobb called attention to a letter written by the clerk to Mr. J. Brown, a member of the board, in June, 1894, in which the hon. member was informed that a resolution passed by a sub-committee to the effect that certain bricks, of which Mr. Brown was the maker, might be supplied for use in the construction of the Brook Hospital, Shooter's-hill, in no way relieved Mr. Brown of the penalty which section 14 of the Metropolitan Poor Law Act of 1867 imposed upon the managers, and which might be recovered at the suit of any common informer. He said that in consequence of the receipt of that letter Mr. Brown requested the architect to omit all reference to the bricks in the specification; but, although that was done, certain bricks of which Mr. Brown was the maker had been used in the construction of the hospital. He moved "That the whole matter be referred to the Local Government Board to ascertain whether section 14 of the Metropolitan Poor Law Act, 1867, has been contravened by Mr. Brown in supplying bricks used in the erection of the Brook Hospital."

Mr. Willmott said a dishonest attack had been made upon Mr. Brown. The bricks manufactured by that gentleman were purchased by merchants and builders all over the country, and, amongst others, by a firm of merchants in London, who supplied a comparatively small number to the builders of the Brook Hospital. Mr. Brown had no control over the merchants or builders, and the only way in which he could prevent such an occurrence was to give up his business entirely.

The motion was lost by 26 to 5 votes.

## OBITUARY.

THE death is announced of Professor Kirk, F.L.S., the well known botanist of New Zealand. Professor Kirk rendered valuable official service in connection with the Department of Woods and Forests. His "Forest Flora of New Zealand" is the standard work upon the forest growths native to the islands. Since the production of his principal work he has continued, from time to time, to publish monographs upon New Zealand timbers. A valuable report on the trees suitable for forest cultivation in the colony was issued by him in 1886, at which time he held the position of Conservator of State Forests in New Zealand, and he was engaged up to the moment of his death upon a great work devoted to the botany of Australasia.

## CHIPS.

The Isolation Hospital, Belper, is being warmed and ventilated by means of Shorland's patent Manchester stoves, with descending smoke-flues, and Shorland's patent Manchester grates, the same being supplied by Messrs. E. H. Shorland and Brother, of Manchester.

The convalescent home at Dundee is about to be extended at a cost of £3,700, by the addition of two wings providing 34 more beds.

On Friday night the members of No. 3 Branch at Leicester of the Amalgamated Society of Carpenters and Joiners met at dinner at the De Montfort Hotel, Wellington-street, in that town, and subsequently presented Mr. E. Thomson with an illuminated address and a handsome marble clock and bronzes in recognition of seven years' services as secretary of the branch. Mr. J. Steer presided.

Lieut.-Colonel A. C. Smith, R.E., Local Government Board inspector, held an inquiry at Surbiton last week into an application by the urban district council for permission to borrow £6,000 for the erection of municipal offices, and £4,500 for the making-up of five roads at Tolworth under the Private Street Works Act, 1892.

The Lord Lieutenant of Ireland unveiled, on Leinster Lawn, Dublin, yesterday, a memorial statue to the late Sir Robert Stewart, the Irish composer. The statue, which is of Carrara marble, has been executed by Sir Thomas Farrell, P.R.H.A.

At their first meeting held on Tuesday, the London County Council accepted the gift of a new recreation ground, seven acres in extent, from the Earl of Northbrook and Viscount Baring at Bromley-road, Lee.

A select committee of the House of Lords decided on Tuesday, in the case of the Inner Temple (King's Bench Walk) Bill, under which powers were sought to build on reclaimed land now forming part of the Temple Gardens, that the preamble had not been proved. The Bill is consequently thrown out.

Four memorial stones were laid on Monday in connection with the enlargement and renovation of the Bethany Welsh Calvinistic Methodist Chapel, Lodge, Brymbo, near Wrexham. The chapel was built over 30 years ago, and has been completely renovated, and will now seat about 500. The total cost was £350. The builders were Messrs. Rogers and Son, Brymbo, and the architect was Mr. G. T. Williams, Liverpool.

The opening services in connection with the new Presbyterian Church, Blundellsands, were held on Sunday. The building has been erected at a cost of about £400, and is intended to provide accommodation for 200 persons.

The new list of members of the Society of Architects just published shows that there are on the roll 514 ordinary members, 17 honorary members, and 10 associates, giving a total of 541 in the three classes. At the corresponding period last year there were 518 members, 17 honorary members, and nine associates, in all, 544.

The South Shields town council have appointed Mr. S. E. Burgess, A.M.I.C.E., surveyor to the Stoke Newington Vestry, London, as borough engineer and surveyor at a commencing salary of £500, rising by annual increments of £25 to a maximum of £700.

A Local Government Board inquiry was held at Swanage last week by Mr. H. H. Law, C.E., respecting an application from the urban district council for sanction to borrow £8,500 for sewerage purposes.

The corporation of York, having applied to the Local Government Board for sanction to borrow certain sums of money for the purpose of carrying out the electric lighting of the city and other works, a public inquiry was held there on Friday before Colonel A. G. Durnford, R.E., inspector of the Local Government Board. The corporation seek power to borrow £23,000 for the sewerage works, £20,000 for the purpose of electric lighting, and £11,852 for street improvements.

### PROFESSIONAL AND TRADE SOCIETIES.

**THE AUCTIONEERS' INSTITUTE.**—The first provincial meeting of the year of the Auctioneers' Institute of the United Kingdom was held on Friday at Oxford, and was largely attended. Mr. James F. Field, of London, the president, occupied the chair at the meeting of the council. A satisfactory report was received from the finance committee showing a balance in hand of nearly £500, and the benevolent fund showed a balance of £338. It was reported that a deputation from a meeting of bailiffs was received early in the year upon the subject of the law of distress and the present position of bailiffs, and it was resolved that it was desirable that a representative meeting of bailiffs should be held to thoroughly discuss the whole subject, and that the views of such meeting should be placed before a committee of the institute for consideration. Forty new members, 24 fellows, and 14 associates were elected. Mr. Alexander, of Cardiff, gave notice of a motion that the qualification for the election of a fellow should be amended, as it was considered by the South Wales branch that five years' practice as an auctioneer was not sufficient to admit anyone to this grade of membership. In the evening a banquet took place in the Municipal Buildings, when Mr. Field was supported by a numerous company.

**THE EDINBURGH ARCHITECTURAL ASSOCIATION.**—The members of this association met on Wednesday in last week in the Royal Institution, Mr. Thomas Ross, president, in the chair. Mr. A. Hunter Crawford delivered a lecture on "Steam Heating and Domestic Hot-Water Supply," illustrating his remarks by a plan, sketches, and a working model. The application of steam for domestic heating, cooking, and hot-water supply from one boiler was described, and the advantages and disadvantages of steam as a heating medium discussed, the lecturer expressing considerable doubt as to the advisableness of its introduction into this country to the same extent as employed in America, where the climatic conditions were so different. The flow of hot-water in pipes was then described, and the results of the experiments on the model given.—On Saturday afternoon the members visited Leith Academy, Leith Links, which has just been erected by the Leith School Board, Mr. George Craig, architect of the school, acting as leader. The company visited the infant classrooms, juvenile classrooms, art-rooms, lecture-hall, chemical laboratories, physical and technical laboratories, and other rooms for a science college, cookery and sewing-rooms. The school has accommodation for 2,097 pupils, and was built at a cost of about £30,000. The building is 122ft. long, and the height of the structure from the pavement to the top of the centre tower is 123ft. The style is Renaissance, with a centre wing and two side wings. The centre wing is one story higher than the rest of the school, which is four and a half stories in height. On the top of this story is a mansard roof, surmounted with a large flèche to be used as a ventilation outlet. The towers surmounting the other two wings are also to be used for ventilation. The heating and ventilation, which is on the plenum system, has been put in by Mr. Key, Glasgow, who explained to the company his method whereby filtered, washed, and warm air is impelled into every classroom, cloak-room, and corridor in sufficient volume to renew the whole air so many times per hour in summer and in winter. The members afterwards visited some of the few remaining buildings of historical interest in Leith, under the leadership of Mr. John Watson, architect. The town house of the Balmerino family, situated in a close off the Kirkgate, was first seen, then an interesting mansion-house in Quality-street; also the Old Custom House, dated 1727, on the Shore, and St. Ninian's Manse.

**THE SOCIETY OF ARCHITECTS AND THE REGISTRATION QUESTION.**—The council of the Society of Architects is desirous of obtaining the views of provincial architects upon the question of registration. They have, therefore, arranged to hold a series of meetings in the provinces, to which the best known architects who reside within a reasonable distance of the localities chosen will be invited. A meeting will be held at the library, Philosophical Hall, Park-row, Leeds, on Friday, March 25, at 7.30 p.m., Mr. Walter Emden, J.P., L.C.C., president of the society, in the chair. An address on "The Statutory Registration of the Profession" will be delivered by Mr.

Ellis Marsland, hon. secretary, and a resolution approving of the principle of compulsory registration will be proposed by Mr. J. Wregitt Cannon, F.R.I.B.A., of Leeds. This will be followed by a general discussion of the subject. In view of the Bill now before Parliament, it is eminently desirable to ascertain at once the attitude of provincial architects on this important subject. A similar meeting will be held at the Arts Club, Grainger-street, Newcastle-on-Tyne, on the following Monday evening, the 28th inst. The chair will be taken by Mr. Silvanus Trevail, F.R.I.B.A., vice-president, of Truro, and a resolution approving of the registration principle will be proposed by Mr. J. J. Lish, of Newcastle, past-president.

### CHIPS.

The Council of King's College, London, have appointed Dr. W. J. Simpson, late Health Officer of Calcutta, to the Professorship of Hygiene.

The parish church of Honingham, Norfolk, has just been reopened, after restoration from plans by Mr. Herbert J. Green, of Norwich. The work includes reflooring and reseating, which have been carried out by Mr. Chapman, of Hanworth.

The twelfth county school erected in Glamorgan-shire under the Welsh Intermediate Education Act was opened at Gwerton on Saturday. The new buildings, which have cost nearly £5,000, afford accommodation for 120 pupils.

On Monday evening the new theatre connected with the training ship *Mercury*, lying in Hamble River, was opened. It has been designed by Mr. Romaine Walker, of London, after the Opera House in Bavaria. It is horseshoe in shape, and fitted with electric light, and is capable of seating about 600 persons. The orchestra, out of sight of the audience, is under the stage. The scenery is from the brush of Mr. Helmsley, of London.

A meeting of the Executive Restoration Committee for the Church of St. Bartholomew the Great, Smithfield, was held last week to celebrate the completion of the work of restoring this historic edifice, and the recovery of the portions so long alienated. Addresses of congratulation were presented to Mr. E. A. Webb, who has been churchwarden and treasurer throughout the whole period, and to his brother, Mr. Aston Webb, F.S.A., F.R.I.B.A., under whose directions, as architect, the works have been carried out by Messrs. W. Dove, Brothers, contractors, at a cost of about £31,000.

Mr. H. H. Law, Local Government Board inspector, held an inquiry at Carisbrooke re a dispute which has arisen between the Newport Town Council and Isle of Wight Rural District Council, as to the terms upon which the corporation are prepared to sanction the parish of Carisbrooke being connected with their sewerage system, and also upon the application of the rural district council to the Local Government Board for permission to borrow a sum of £2,000 for the purposes of the works of sewerage for the village of Carisbrooke.

A preliminary meeting of creditors in the matters of Michael Harmel and Myer Sayers, trading in partnership as the South Main Street Furnishing Company, of Cork, also of Michael Harmel, Lombard-street, Dublin (on his own account), was held at Manchester, on Friday. The liabilities of the South Main Street Furnishing Company, which was only commenced in February, 1897, amount to £2,356, and the total deficiency is £3,914. After a long discussion an offer of 7s. 6d. in the pound, payable within twelve months, was refused, and eventually it was agreed that unless 10s. in the pound was forthcoming, the matter should be wound up in bankruptcy.

The Southampton Corporation were informed at their last meeting that, on the instructions of a committee, the borough engineer, Mr. W. B. G. Bennett, had reduced the estimated cost of the proposed municipal lodging-house from £14,500 to £10,000, the changes including the reduction in accommodation from 225 to 189 beds. After a prolonged discussion, and a division, the report was adopted, and Mr. J. F. Crook was appointed to take out the quantities for the building at a commission of 1½ per cent, preparatory to inviting tenders for the work.

The burial of the late Mr. Deputy James Edmeston, F.R.I.B.A., of 42, Old Broad-street, E.C., whose death we recorded in our last issue, took place at Brompton Cemetery on Thursday in last week, in the presence of a large gathering of relatives and friends. The principal mourners were Mrs. Hodges, Miss Edmeston, and Mrs. Dow (daughters), Dr. Dow, Mr. J. S. Edmeston, and Mr. J. Edmeston, jun. (grandsons). There were present also: Mr. E. Gabriel (the late Deputy's partner), Sir G. Harris, Mr. P. Harris, Mr. H. H. Collins, F.R.I.B.A., Mr. F. Stanley, C.C., Mr. E. C. Beedell, C.C., Mr. W. Brown, C.C., Lieut.-Colonel Thompson, C.C., and Mr. R. W. Edwards, C.C.

## Building Intelligence.

**BORDESLEY.**—A new building, to be known as the Imperial Theatre, is to be at once erected on a site in High-street, at the junction of Clyde-street, and nearly opposite to the railway station. Plans have been prepared by Messrs. Owen and Ward, architects, of Birmingham. The stage will be 70ft. by 45ft., and the auditorium 70ft. by 65ft., and providing sitting accommodation for 2,700 persons. It is divided into orchestra and pit-stalls, pit, circle, and gallery, with six private boxes. There will be only two tiers above the pit level, and these are to be constructed on the cantilever principle. The principal entrances will be from the High-street into a hall 26ft. by 24ft., with a domed ceiling, and a marble staircase leading to the grand circle and balcony. The internal decorations will be in Louis XIV. style, the prevailing colours being turquoise-blue, cream, and gold. The external elevation will have a frontage of 100ft. in length, and will be of red brick with buff terracotta dressings, and an iron and glass verandah, supported on pillar-lamps, will span the footpath. The building, irrespective of fittings, is estimated to cost £12,000. The new theatre will be completed ready for opening by Christmas next.

**DUNBLANE.**—In consequence of the yearly increasing number of visitors to Dunblane Hydro pathic, the proprietor has decided on extensive additions. A new wing will be added to the north end of the building, greatly enlarging the existing dining-room accommodation. The additions will afford room for nearly 100 persons, so that about 250 may sit down to dinner when the alteration has been carried out. In the basement underneath the new dining-room is a servants' hall and a servants' dormitory. Next year the symmetry of the frontage will be insured by the erection of a similar wing at the other end adjoining the present drawing-room. Plans for the extension have been prepared by Messrs. James M'Laren and Sons, architects, Dundee, while the contract for the mason work has been secured by Messrs. J. and C. Hay, builders, Dundee. The extension is to be completed in time to accommodate summer visitors.

It is announced that all applications for licenses for hoardings, scaffolds, shores, &c., upon or over the public-ways of the City of London, and for placards and advertisements upon the same, should for the future be made direct to the town clerk at the offices of the Public Health Department, Guildhall.

A vicarage house has lately been built at Weston, near Southampton. The building is a plain and solidly-built red brick structure, designed by Messrs. Mitchell and Gutteridge, architects, of Southampton, and executed by Mr. Rashley. It was opened on Monday in last week.

Very good business was done last week at the Auction Mart, among the notable features being the continued demand for freehold ground-rents at reasonable prices, and for building land in good positions. The aggregate realisation, as registered at the Estate Exchange, amounted to £165,354—a long way in advance of the corresponding week of last year, when the total recorded was £96,654.

The new Roman Catholic Church in Beverley was formally opened on Friday by the Bishop of Middlesbrough. The building is of stone, light being admitted by eight traceried windows, two of which, near the altar, are of stained glass. The pews are of pitch-pine, accommodating 200 worshippers. There is a gallery over the entrance for the organ and choir, and on the north side of the altar a small sanctuary and confessional.

At a meeting of the Lynn Town Council, on 9th inst., the resignation of Mr. E. J. Silcock, C.E., borough engineer, was accepted; but it was decided by the council to retain Mr. Silcock's services for the completion of the works for a new water supply to the town and new sewerage scheme which have been designed and commenced by him. We understand that Mr. Silcock has been appointed engineer to the King's Lynn Harbour Conservancy Board, and that he will also carry on a general practice as a civil engineer.

At a special meeting of Haddington Town Council, held on Friday, a report relative to the new bridge scheme was submitted by Messrs. Carfrae and Belfrage, C.E., Edinburgh. The engineers report in favour of the Market-street route, and estimate that a bridge, plans of which were produced, could be erected for the sum of £5,000, exclusive of approaches. The council agreed to ask the engineers to supply detailed figures regarding the various routes suggested.

## TO CORRESPONDENTS.

[We do not hold ourselves responsible for the opinions of our correspondents. All communications should be drawn up as briefly as possible, as there are many claimants upon the space allotted to correspondents.]

It is particularly requested that all drawings and all communications respecting illustrations or literary matter should be addressed to the EDITOR of the BUILDING NEWS, 332, Strand, W.C., and not to members of the staff by name. Delay is not infrequently otherwise caused. All drawings and other communications are sent at contributors' risks, and the Editor will not undertake to pay for, or be liable for, unsought contributions.

Cheques and Post-office Orders to be made payable to THE STRAND NEWSPAPER COMPANY, LIMITED.

## TERMS OF SUBSCRIPTION.

One Pound per annum (post free) to any part of the United Kingdom; for Canada, Nova Scotia, and the United States, £1 6s. 0d. (or 6dols. 30c. gold). To France or Belgium, £1 6s. 0d. (or 33fr. 30c.). To India, £1 6s. 0d. To any of the Australian Colonies or New Zealand, to the Cape, the West Indies, or Natal, £1 6s. 0d.

## ADVERTISEMENT CHARGES.

The charge for Competition and Contract Advertisements, Public Companies, and all official advertisements is 1s. per line of Eight words, the first line counting as two, the minimum charge being 5s. for four lines.

The charge for Auctions, Land Sales, and Miscellaneous and Trade Advertisements (except Situation advertisements) is 6d. per line of Eight words (the first line counting as two), the minimum charge being 4s. 6d. for 40 words. Special terms for series of more than six insertions can be ascertained on application to the Publisher.

Front-page Advertisements 2s. per line, and Paragraph Advertisements 1s. per line. No Front-page or Paragraph Advertisement inserted for less than 5s.

Advertisements for the current week must reach the office not later than 3 p.m. on Thursday. Front-page Advertisements and alterations in serial advertisements must reach the office by Tuesday morning to secure insertion.

## SITUATIONS.

The charge for advertisements for "Situations Vacant" or "Situations Wanted" is ONE SHILLING FOR TWENTY-FOUR WORDS, and Sixpence for every eight words after. All Situation Advertisements must be prepaid.

## NOTICE.

Bound copies of Vol. LXXIII. are now ready, and should be ordered early (price Twelve Shillings each), as only a limited number are done up. A few bound volumes of Vols. XXXIX., XL., XLI., XLVI., XLIX., LI., LIII., LVIII., LIX., LXI., LXII., LXIII., LXIV., LXV., LXVI., LXVII., LXVIII., LXIX., LXX., LXXI., LXXII. may still be had, price Twelve Shillings; all the other bound volumes are out of print. Most of the back numbers of former volumes are, however, to be had singly. Subscribers requiring any back numbers to complete volume just ended should order at once, as many of them soon run out of print.

A. S. P. (We know few books on the subject to which you refer. If you apply to the Secretary of Institution of Surveyors, Savoy-street, for a copy of their examination syllabus, you will find a list of subjects, and we believe a list of textbooks for estate-surveying is given. The subjects you ought to study are those on estate management, law of landlord and tenant, dilapidations, land surveying, agricultural buildings and drainage, road-making, sanitary work. Get the "Handbook of House Property" by Tarbuck, Inwood's "Tables for Purchasing Estates, &c.," Wheeler's "Appraisers' and Estate Agents' Pocket Assistant" (Crosby Lockwood), and inquire of Batsford, 94, High Holborn, for books on any of these subjects.)

RECEIVED.—C. H. W.—O. V.—L. T. and Co.—N. P. G.—S. K. and Son.—D. C.

## "BUILDING NEWS" DESIGNING CLUB.

DRAWINGS RECEIVED. — "Bernard," "Petticoats," "Strax," "Ivy," "Dacas," "Olliwops," "Notts," "Panfle," "Alesia," "Tee-square," "Rydal," "Klondyke," "Centaur," "Cobden," "Giaour," "Crow," "Lany," "Derige," "Don't Know," "Hotspur," "Nowhere," "Cedmon," "Chess" (nearly a week late).

## Intercommunication.

## QUESTIONS.

[11914.]—**Regimental Colours.**—Can any reader advise as to how to preserve old regimental colours, which have suffered severely from being kept against the damp walls of a church? Is it possible to mount them on strong linen or fine canvas? Are there any firms who make a speciality of such work?—R. B. C.

[11915.]—**Rendering Lime Concrete with Cement.**—Lime, gravel, and sand are obtainable here at very low prices. The lime is a good quality, of very fat nature. I have built a flight of steps with lime concrete, and rendered it with cement, the result being not very satisfactory, which I ascribe to the amount of clay in the sand used in the cement rendering and the too small quantity of cement. I am told that cement will not hold to lime concrete, the two materials having no affinity, though I have often rendered a plain lime concrete floor with cement with satisfactory results. Will any readers oblige me with their opinion?—AUSTRAL.

[11916.]—**Dry and Wet Rot.**—Can any of your subscribers give me a good remedy for both dry rot and also wet rot with fungus growth, &c.?—INQUIRER.

[11917.]—**Brick and Timber Work.**—I shall be obliged if a practical reader will give a specification for a brick gable in which brick and timber framing are employed, stating the ordinary dimensions of the uprights and other timbers, thickness of wall, load, and other details of the corbeling over of the gable. The description will be useful to others beside myself.—A COUNTRY BUILDER.

[11918.]—**Witness to Building Agreement.**—Can any reader of the BUILDING NEWS inform me if, in the case of an ordinary building agreement between the owner and the contractor, the architect can sign the same as a valid witness to the signatures of the contracting parties, or whether the signature of an outside person as witness is preferable?—LECTOR.

[11919.]—**Hygeian Rock Building Composition.**—Will anyone give particulars as to how this composition can be applied to walls—whether it is best used between two walls, and what thickness, or as an outside or inside lining to cellar walls or storage tanks?—G. WILLIAMS.

[11920.]—**Hollow Wall Ties.**—A friend is thinking of building a house with hollow walls. What is the strongest and best form of iron tie, and the name it is known by? I think the stoneware brick gives more opportunity for the moisture to pass through, as it affords a better lodgment for mortar droppings. I shall be glad of any practical advice, the distance the ties should be placed, size of cavity, &c.—DAMP-PROOF.

[11921.]—**Facing Bricks.**—What bricks are recommended for the front of a house in a West-end street? They must be good, hard, and of deep colour, though absolute uniformity of tint is not desired.—L. O.

## REPLIES.

[11909.]—**Silicate Cotton.**—Replying to "W. H., Manchester," in your issue of 4th inst., the fault of his method of applying the silicate cotton sheets is that he failed to secure entire insulation by leaving the joists free to conduct the sound. Complete insulation is essential to complete success, and this is obtained by fixing the "sheets" underneath the joists, say from centre to centre of each alternate joist. Fillets can then be fixed to carry the laths for the ceiling, or, better still, Jones's patent combined silicate cotton and plaster slabs can be used, thus economically combining the silicate cotton sheets and the plaster ceiling in one process.—M. H.

[11911.]—**Bending Moment.**—In mechanics a "moment," or "moment of a force," about a point is said to be its tendency to produce rotation about that point. We speak of the moment of a lever about the fulcrum, of the handle of a pump, the rotating effect being measured by the distance of the force from the axis of rotation. The "bending moment" of a beam is the load relatively to the cross-section, or the weight acting to bend the beam effectively. If we suppose a cantilever beam with the weight applied at the free end, the bending moment is  $w \cdot z$ ,  $w$  representing the weight, and  $z$  the distance of weight from the fulcrum, the strain or moment being proportional to the distance. In other words, the "bending moment" of a beam has been defined as follows:—"The bending moment at any point in a beam is the algebraic sum of the moments with respect to that point of all the external forces acting on the portion of the beam on either side of that point," and the amount of the moment can be determined graphically, as shown in all treatises on mechanics.—G. H. G.

[11912.]—**Painting Galvanised Iron.**—White-lead unquestionably sets up a galvanic action on the iron, and is not recommended. For toughness and adhesive qualities, iron oxide paint with pure oil is no doubt one of the best coverings for iron. Considerable experience in the painting of iron structures in America proves the value of oxide of iron paint to corrugated roofs, especially when the metal has been scraped clean. The subject has lately been discussed in the columns of the BUILDING NEWS, and I think "C. F. M." will find some useful remarks on the subject by referring to two or three of the last volumes.—G. H.

## CHIPS.

An alabaster tablet has been erected in Durham Cathedral by the family of the late Dr. Malby (1770-1859) in memory of the deceased prelate, who was Bishop of Chichester from 1831 to 1836, and Bishop of Durham from that year till 1856. It is placed in the north transept, and bears an inscription, surmounted by the Episcopal arms.

Mr. W. Y. Macgregor and Mr. W. S. Macgeorge, painters, were elected to the rank of Associate at a general assembly of the Royal Scottish Academy on Wednesday.

Decorations, designed by Mr. Aston Webb, have just been completed at St. John's, Notting Hill. The colour scheme is green, red, and yellow, sparsely relieved with gold—all kept in a light key, as the chancel is a dark one. The greatest elaboration has been reserved for the east wall. On either side of the east window are painted full-length figures of St. John and the Blessed Virgin. The general wall faces of the chancel are diapered with pomegranates and bluebells, emblems of St. John. Above the arch is the Dove, and on either side two censuring angels (9ft. high). The ornament generally is designed in a Late character, the emblematic grape and vine-leaf being mainly used.

The national harbour works at Dover have been commenced this week by the inclosure of an area of foreshore between the Admiralty Pier and Shakespeare Cliff at the western end of the town. The inclosure will be used for the purpose of making the concrete blocks for the extension of the Admiralty Pier section of the work, which is to be continued to a distance of 4,000ft. into the sea.

## LEGAL INTELLIGENCE.

PUBLIC BUILDING DISTRICT SURVEYORS' FEES.—LONDON BUILDING ACT, 1894.—DICKSEE V. BULLERS.—At Southwark Police Court on March 14, Mr. Fenwick gave his decision in this case. The plaintiff, Mr. Bernard Dicksee, district surveyor for East Newington, summoned Mr. J. Bullers, the builder employed, for £7 17s. 6d., district surveyor's fees, in respect of certain alterations made to St. Matthew's Church, New Kent-road. The case was heard on January 26, when evidence was given by the plaintiff that the work done consisted of removing the old chancel floor, and erecting a new chancel floor supported on dwarf walls at a higher level than the old floor, and extending some 9ft. further into the body of the church, several pews being removed to make room for this. The new floor had seven steps up to the altar, instead of the previously existing three steps. There was no alteration to the walls or columns of the church, except that the bases of the small attached columns at the east end were taken out and refixed at a higher level. No building notice was in the first instance given by the defendant, though one was subsequently given when demanded by the district surveyor. The district surveyor surveyed the work from time to time until completion, when he issued his certificate under Sec. 78. When, however, a demand was made for the fees, defendant wrote to the plaintiff that he was instructed by the owners not to pay. It was contended by the district surveyor, who appeared in person, that the work done came within Secs. 78 and 80, brought into operation by Secs. 207 and 209, and that the work must be done as approved by him. It was argued by counsel for defendant that the Act did not apply in this case, and the case of "Venner v. McDonell" was quoted. Mr. Fenwick, in giving his decision, said that he had come to the conclusion that the correct reading of the Act was that for the Act to apply the work done must be "work affecting, or likely to affect, the building," as stated in the latter part of Sec. 78. It therefore only remained for him to decide as a fact whether the work done was of such a character. For explanation he must refer to the earlier part of the section which read that "Every public building, including walls, roofs, floors, galleries, and staircases shall be constructed in such a manner as may be approved by the district surveyor." The question was, therefore, Was this work such as affected the construction of the church? He had heard the evidence and made a personal inspection of the building, and he had further an excellent plan of the alterations to guide him, and he could come to no other conclusion than that it did—therefore, the district surveyor was entitled to the fees. Addressing the plaintiff, the magistrate asked whether, having regard to his (plaintiff's) previous offer to accept less, he was still disposed to do so, and asked what amount was suggested. Plaintiff stated that no amount had been mentioned, and he would prefer to leave the matter entirely in the magistrate's hands. Upon the magistrate pressing the plaintiff for his view of the amount, he suggested one-half. The order was therefore made for £3 18s. 9d., and 3s. costs.

Alterations are being made at the Corn Exchange, Melton Mowbray, embracing the ventilation, which is now carried out on the Boyle system.

In the House of Commons on Wednesday, a Bill, introduced by Sir Elliott Lees, to prevent the removal of monuments which have been erected in cathedrals or churches out of public money in pursuance of a vote by Parliament, was read a first time.

In the north transept of Ely Cathedral there are two recessed bays of Abbot Simeon's original work, the finest examples of Early Norman in this country. The recess nearest the choir is known as Northwold's Chapel, and within this a work in alabaster is now being erected, consisting of a reredos and altar. Beneath a pierced canopy are figures—in the centre the Saviour, on either side an angel bearing a censer, and below these six angels in prayerful pose. The idea of a place for private prayer is due to a Canon, at whose cost it will be carried out. It will be dedicated to St. Edmund, King of East Anglia.

The parish church of Falmouth was reopened last week by the Bishop of Truro after reconstruction. The unsightly old roofs have been remodelled on an elaborate scale. The huge north and south galleries have been removed, a west gallery has been retained but rearranged, the dilapidated pewing removed, and new seating has been substituted. The old floor (which was composed of patches of woodwork, and large iron gratings, and loose stone slabs and tiles) was taken up, the numerous vaults filled in, and a new floor laid down with wood blocks, under the seating. The scheme for the alterations includes a new apse and a new north tower; but only the first portions of Mr. Edmund Sedding's plans have been carried out, for want of funds. Over £3,000 has been expended on these improvements.

### WATER SUPPLY AND SANITARY MATTERS.

**THE LONDON WATER SUPPLY.**—At Monday's sitting of the Royal Commission on the Metropolitan water supply, Mr. W. H. Dickinson, chairman of the water committee of the late London County Council, was recalled and cross-examined by Lord R. Cecil for the Hertfordshire County Council, and said the policy of the Council with regard to the outside areas was to hand over to them entirely the distribution, and a proportionate share of the right to draw water from the Thames according to the number of consumers. The witness expressed a decided preference for a policy of purchase rather than one of administrative control. Sir John Lubbock, M.P., said that in his opinion the purchase by the London County Council of the undertakings of the eight water companies would not be expedient in the interests of London, either as regarded the purity of the water supply or from a financial point of view. He cited figures to show that purchase would involve increased cost to the ratepayers. Neither Government nor municipal management could be expected to compete with private management in economy or efficiency, and was only defensible in special cases. He doubted whether the tendency of public opinion was really in favour of placing the water supply in the hands of the County Council; and it was undesirable on several grounds that the governing body of the Metropolis should be a gigantic employer of labour. In preference to a policy of purchase he advocated a control with representatives of the ratepayers on the board of each company. By such an arrangement the advantages of purchase would be secured, and its dangers avoided.

**ROYAL COMMISSION ON THE SEWAGE QUESTION.**—The Royal Commission about to be appointed to consider the various phases of the sewage question will be a small body, consisting, in all probability, of seven members. The chairman will be supported by a chemist, a bacteriologist, a couple of engineering experts familiar with the different methods of urban drainage, and probably two Local Government Board officials specially qualified to speak with authority upon sewage matters.

**WATER-BORNE TYPHOID.**—At the Sanitary Institute on Wednesday night in last week a paper was read by Dr. Childs, of University College, on water-borne typhoid. After reviewing the various causes of typhoid fever, he pointed out that the protection of water supplies was the one measure calling for immediate action. The present law was quite inadequate. The first requirement was the thorough and systematic inspection of the water supplies from source to distribution; but the duty of taking action was thrown on the sanitary authorities who had only enabling, not compulsory, powers, and were themselves often the greatest polluters. The chief obstacle to reform was the ignorance and indifference of the public. He concluded by recommending (1) that sanitary authorities should have free access to water supplies, and should provide for their inspection and analysis; (2) that water companies should publish full information as to their water; (3) that they should be required to make regular inspections and analyses, and publish the reports; (4) that they should be made responsible for the consequences of pollution; (5) that wilful pollution of water should be a penal offence; (6) that public authorities should be appointed for the care and protection of watersheds. A discussion followed. Dr. Sims Woodhead drew attention to the vitality of the typhoid bacillus in soil, and the consequent need of preventing soil pollution. He suggested that sanitary authorities should have rights of supervision over water companies, and that the responsibility for pronouncing on the sufficiency of the water should fall upon them. The whole question should be placed under the control of a central board. Major Flower, engineer to the Lea Conservancy Board, advocated individual action in getting rid of river pollution. Dr. Louis Parkes thought the protection of watersheds might very well be intrusted to county councils. Dr. Childs, in reply, laid stress on the primary necessity of diffusing knowledge among the people.

A destructive fire broke out on Friday night in St. Edmund's Roman Catholic Church, Walkden Moor, Walkden, resulting in the complete gutting of the building, which was of pitch-pine, covered with felt and galvanised iron. The fire originated through a leakage of gas in the vestry. The damage amounts to over £1,000. The whole of the church furniture, including a valuable organ, was destroyed.

An important inquiry was opened in the Withington Town Hall, on Friday, by W. W. E. Fletcher, an inspector of the Local Government Board, into an application made by the Withington Urban District Council for sanction to borrow £5,500 for the purchase of Baguley Lodge Estate, 4½ miles from Withington town hall, as a site for an Infectious Diseases Hospital. Mr. Mountain, surveyor to the urban district council, explained the scheme.

### PARLIAMENTARY NOTES.

**THE ARCHITECTS' REGISTRATION BILL.**—In the House of Commons on Wednesday, Mr. Li. Atherley-Jones brought in the Bill to provide for the Registration of Architects. The measure was read a first time.

### CHIPS.

The 20th annual dinner of the Builders' Clerks' Benevolent Institution will be held on Tuesday, April 5, at the King's Hall, Holborn Restaurant, when Mr. R. C. Foster, of Rugby (Foster and Dicksee), the President, will occupy the chair.

Messrs. Warner and Son, of Cripplegate, have now completed the recasting of the old church bells at Sevenoaks. They have been rehung in the belfry, and will be rung for the first time on Sunday.

The Hotel Victoria, at Newmarket, which has been erected from designs by Mr. Walter Emden, P.S.A., was opened yesterday (Thursday). The building, the architecture of which is of the Flemish character, stands on the site of the old Greyhound, in the High-street. The entire furnishing of the establishment has been carried out by Messrs. Maple and Co.

Messrs. Balwin-Latham, C.E., and W. J. Dibdin, F.I.C., have prepared a scheme for the purification of the sewage of Ashton-under-Lyne, by the bacteria process.

The East window of the church of St. Michael at St. Albans, lighting the famous effigy of Lord Bacon in the chancel, has just been filled with stained glass, at the cost of the Earl of Verulam. The window, of three lights, has as its subject the Transfiguration. Our Lord occupies the central light, and on either side are figures of Moses and Elijah; while underneath are the three apostles Peter, James, and John.

In the Court of Appeal, on Friday, before the Master of the Rolls and Lords Justices Rigby and Vaughan Williams, judgment was given in an appeal, "The Overseers of Worthing v. the Surveyor of Taxes," from the judgment of a Divisional Court. The question at issue was whether glass-houses in or on a market garden were to be rated as buildings or as agricultural land under the Agricultural Rates Act, 1896. A Divisional Court had decided that the buildings were to be treated as part of the market garden, and rated as such. The surveyor of taxes appealed, and their Lordships now by a majority (Lord Justice Williams dissenting) allowed the appeal, with costs in that court and below, holding that the buildings must be rated as such, and not as agricultural land.

The ceremony of opening the new Wesleyan Sunday-schools, erected in connection with the Colman-street Church, Great Thornton-street circuit, Hull, was performed on Friday afternoon. Some £3,500 has been expended on the new premises. The central hall will accommodate about 800 children; but there are in addition 17 classrooms and other dormitories.

A decorator and grainer, named Jinks, 56 years of age, was, in the Queen's Bench Division on Friday, awarded £500 damages against Messrs. Lawrence and Sons, contractors, for personal injuries. As the plaintiff was walking along the Strand last June a piece of timber, weighing 200lb., which was being shifted from a mansion at 336, Strand, W.C., by a workman in the defendant's employ, fell on him, causing serious injuries, one of the effects of the accident being that plaintiff's left leg had to be amputated below the knee, while he also lost the sight of one eye.

On Thursday, in last week, Mr. G. W. Willcocks, M. Inst. C.E., held an inquiry at Pembury on behalf of the Local Government Board, into an application by the Tonbridge Rural Sanitary Authority for a provisional order to compulsorily acquire lands required for the purposes of a sewerage scheme for the parish of Pembury. Mr. W. Vaux Graham, engineer of the scheme, explained the proposals.

The Education Committee have decided that the associateship of the Royal College of Art is to be granted to all those who, having passed satisfactorily through at least two years' training in the Royal College of Art or National Art Training School, have obtained the Art Master's Certificate, Group I., and two certificates of other groups. Applications for the diploma of associateship should be made by those past students of the college who are qualified for it under the above rule to the secretary, Department of Science and Art, South Kensington, London, W.

At the Old Bailey, on Friday, John Jolly, 47, builder, was indicted for shooting, with intent to murder, police-constable Hill, of Stratford, for causing him to be arrested for disorderly conduct. The bullet struck the constable behind the ear, and he is now suffering from facial paralysis. Justice Grantham, in sentencing the accused to seven years' penal servitude, said that if Hill had died nothing could have saved Jolly from the gallows.

### Our Office Table.

"ARCHITECTURE VERSUS BUILDING" was the title of a lecture given at Carpenters' Hall on Monday evening by Professor Banister Fletcher, C.C., J.P. Mr. A. Preston, past-master of the company, presided. Professor Fletcher pointed out that the great end of art was pleasure, and proceeded to describe the affinity of art and architecture. To show how practical was the work of the architect, he gave some drawings of buttresses, indicating first the ordinary "shore" of the builder, and secondly the same end accomplished by the architect's more pleasing buttress and flying buttresses. The point the speaker emphasised was that no ornamentation of architecture could be good which structurally was bad, and this he illustrated by a specimen of an exceedingly ugly Decorated French buttress. Passing on to the necessity of the study of proportion as an essential characteristic of architecture, the professor gave some useful rules which might be generally applied in the construction of ordinary houses, dealing more especially with the proportions of windows, doors, and staircases. Many excellent views were shown, some of them of the most admired architectural types known to the world; and, as a concluding remark, the lecturer pointed out that nothing was beautiful in a design unless it was meant to serve some good end. Finally, some lantern views were shown of famous buildings.

The London School Board have received a report from the School Management Committee with regard to a scheme drawn up by Mr. Lyulph Stanley for regulating the work in connection with the alteration and improvement in schools. Mr. Stanley stated that the Board had from time to time sanctioned the improvement of the earlier schools by the addition of halls better cloak-rooms, wider corridors, additional staircases, and so forth. The time had come when the Board should consider systematically and methodically the question of improving its older schools. The Works Committee had furnished a list of 25 schools where halls could be added at a moderate cost. There were some of the older schools, especially in the poorer and crowded neighbourhoods, where improvements were greatly needed, although in some cases they would be very costly. It was suggested that the School Management Committee should draw up a list of such schools, and that the Works Committee should be asked to report whether it was practicable to improve these schools, and, if so, at what cost. The Works Committee should also report in the case of all the schools in either list whether it would be practicable to enlarge them, and whether the improvements could be more easily carried out along with enlargement. It was probable that, taking one school with another, at least 16 schools a year could be brought up to date. There were in all 175 schools without halls, which should, sooner or later, be dealt with. Under this scheme they would be taken in hand gradually, and probably nearly all be made suitable in about a dozen years. The School Management Committee have approved of the principles set out in Mr. Stanley's memorandum, and proposed that £100,000 in the coming year be set apart on loan for the purpose of improving old schools. Consideration of the matter has been postponed.

At a special meeting of the Birmingham, Tame, and Rea District Drainage Board, held on Friday, a vote of condolence with the family of the late Mr. W. S. Till, for many years engineer to the board, and expressing appreciation of his distinguished services and zeal as an engineer, was passed. It was decided to terminate the arrangement with the Birmingham Corporation by which the surveyor of that city acts as engineer to the board, and the resignation of Mr. John Price, city surveyor, of the office of deputy engineer to the board, was accepted, with thanks for past services. Mr. John Knight, at present assistant engineer, was appointed as engineer, with a residence at Tyburn and a salary of £600 a year.

The Department of Science and Art has received information, through the Foreign Office, of an Art Exhibition to be held in Vienna this year in celebration of the 50th anniversary of the Emperor of Austria's accession. The exhibition will be opened about the middle of April and closed at the end of June, and the works will be arranged in the following groups:—Architecture, works of sculpture, painting, reproducing arts. Further information respecting the exhibition

can be obtained from the Committee of the Jubilee Exhibition of Fine Arts, 1898, Kunstlerhaus, I Lothringerstrasse, No. 9, Vienna.

MEETINGS FOR THE ENSUING WEEK.

MONDAY.—Carpenters' Hall Free Lectures. "Municipal Control of Buildings," by Dr. G. B. Longstaffe. 8 p.m. Society of Arts. "The Thermochemistry of the Bessemer Process," Cantor Lecture No. 2 by Professor W. Noel Hartley, F.R.S. 8 p.m. Surveyors' Institution. "Tithe-Rent Charge Recovery," by H. M. Grellier. 8 p.m. Royal Institute of British Architects. "Heraldic Drawing and its Adaptation," by J. D. Crace. 8 p.m. TUESDAY.—Institution of Civil Engineers. Discussion on "Calcium Carbide and Acetylene." 8 p.m. WEDNESDAY.—St. Paul's Eccelesiological Society. "Notes on the Brasses of Middlesex," by Mill Stephenson, F.S.A. 7.30 p.m. Society of Arts. "The Preparation of Meat Extracts," by C. R. Valentine. 8 p.m. THURSDAY.—Society of Architects. "The Position of Owners of Property with Regard to Rights of Light and Other Easements, with a Suggestion for Future Legislation," by A. A. Hudson, Barrister-at-Law. St. James's Hall, Piccadilly, W. 8 p.m. Institution of Civil Engineers. "Geology in Relation to Engineering," by Professor W. Boyd Dawkins, F.R.S. 8 p.m. FRIDAY.—Architectural Association. "Constructional Steelwork," by T. C. Cannington. 7.30 p.m.

THE ARCHITECTURAL ASSOCIATION. MARCH 25th, ORDINARY GENERAL MEETING. 9, Conduit-street, W. 7.30 p.m. Paper by Mr. T. C. CANNINGTON on "CONSTRUCTIONAL STEEL WORK." MARCH 26th, SPRING VISIT to Lord Windsor's House, corner of Mount-street and Park-street, W. Mr. F. B. Wade, Architect. 3 p.m. E. HOWLEY SIM, } Hon. Secs. G. B. CARVILL, }

The Society of Architects.

Founded 1884. Incorporated 1893.

The FIFTH ORDINARY MEETING of the Society of Architects for the Session 1897-98 will be held at the Rooms of the Society, at St. James's Hall, Piccadilly, W., on THURSDAY, March 24th, 1898, at Eight o'clock p.m., when a Paper will be read by Mr. A. A. HUDSON, A.S.L., Barrister-at-Law, entitled "THE POSITION OF OWNERS OF PROPERTY WITH REGARD TO RIGHTS OF LIGHT AND OTHER EASEMENTS, with a SUGGESTION FOR FUTURE LEGISLATION."

ELLIS MARSLAND, Hon. Sec. MONTAGU BALDWIN, M.A., Sec.

CHIPS.

At Newquay, Mr. O. E. Meade King, M.Inst. C.E., held a Local Government Board inquiry on Wednesday, concerning the application of the Newquay Urban District Council to borrow £400 for works for street improvements, £330 for the provision of a steam fire-engine, and £2,300 for sewerage works.

On Thursday evening in last week the new organ built in the Congregational Church, Castleton, Lancs, was opened. The organ has been built by Messrs. Driver and Company, of Burnley, at a cost of between £300 and £400.

An inquiry was held at the council-room, Morecambe, on Friday, by Colonel R. J. Hepper, Government inspector, into an application by the district council to borrow £1,418 for the purpose of extending the water supply, and £10,000 for the extension of the electric lighting. It was stated that since the last census was taken the population had increased by nearly 4,000, whilst the assessable value was estimated at £45,600.

Mr. French has been appointed to the chief agency of Lord Penrhyn's Carnarvonshire, Denbighshire, and Anglesey estates, in succession to the Hon. W. E. Sackville West, who has retired.

The organ of Clyst-Hydon Church, Devon, after fifteen years of silence, was reopened on Sunday. The work of reconstruction and renovation has been carried out by Messrs. Minns and Co., of Taunton.

The latest addition to the vast collection in the private apartments at Windsor Castle is a life-size bust in white marble of Prince Henry of Battenberg, by the Countess Gleichen, daughter of the late Prince Victor of Hohenlohe-Laugenberg. The bust has been placed on a pedestal at the upper end of the corridor.

The will and codicil of Mr. Charles Park, of 154, Piccadilly; 99, Long Acre; 157, Haverstock Hill; and Wingham Lodge, Minster, artist colourman, who died on January 28th, have been proved, the value of the personal estate amounting to £33,898 18s. 7d.

Trade News.

WAGES MOVEMENTS.

THE STATE OF EMPLOYMENT AND TRADE.—The monthly report for February of the Labour Department is based on 2,290 returns—viz., 1,648 from employers, 508 from trade unions, and 134 from other sources. The state of employment shows a marked improvement compared with a month ago, though not quite up to the level of the corresponding month in last year. The labour market has been very little disturbed by disputes, and the changes in wages have also been comparatively unimportant. In the 116 trade unions making returns with an aggregate membership of 466,362, 4.4 per cent. were reported as unemployed at the end of February, compared with 4.96 per cent. at the end of January, and with 3 per cent. with February, 1897. Employment in the building trades is very good, the percentage of unemployed union members being 1.7, compared with 2 per cent. for January, and also for February, 1897. The furnishing trades are more actively employed, the percentage of unemployed union members having fallen from 5.1 at the end of January to 2.8 at the end of February. The percentage for February, 1897, was 3.

Paisley Town Council have adopted a resolution declaring that the value of land apart from improvements should be rated for local purposes, and has signed a petition to Parliament for the necessary powers to give effect to this principle.

Operations have now been commenced in connection with the erection of the new lighthouse and fog-signal station for the Irish Channel, on the Blackhead, N.B., a bold promontory over two miles north of Portpatrick harbour, and commanding a wide expanse of the Channel. Whinstone is being quarried on the adjoining farm of Killantringan. The buildings will comprise a light-tower, engine-room, and dwelling-houses for the principal and assistant lightkeepers.



BILLS OF QUANTITIES, PLANS, &c.

Lithographed in best style and with great expedition by PARTRIDGE & COOPER, ARCHITECTS' AND SURVEYORS' LITHOGRAPHERS, 191 & 192, Fleet St., and 1 & 2, Chancery Lane, London, E.C. Special Prices quoted for Large Jobs. LIBERAL DISCOUNTS ACCORDING TO ARRANGEMENT.

FAMBRINI & DANIELS, MANUFACTURERS OF IMPERISHABLE CONCRETE MASONRY FOR

CORNICES, STRING-COURSES, MODELLED PANELS, AND EVERY STONE-WORK REQUISITE. LANDINGS and Plain or Moulded and Mitre STEPS, durable throughout. WORKS AND OFFICES: LINCOLN.

PILKINGTON & CO. (ESTABLISHED 1838), MONUMENT CHAMBERS, KING WILLIAM STREET, LONDON, E.C.

Registered Trade Mark: POLONCEAU ASPHALTE

Patent Asphalt and Felt Roofing. ACID-RESISTING ASPHALTE. WHITE SILICA PAVING.

SEYSSSEL ASPHALTE. HAM HILL STONE. DOULTING STONE. THE HAM HILL & DOULTING STONE CO.

Incorporating THE HAM HILL STONE CO. and C. TRASK and SONS (THE DOULTING STONE CO.) Chief Office: NORTON, STOKE-UNDER-HAM, SOMERSET. London Agent: Mr. E. A. WILLIAMS, 16, CHAVER STREET, STRAND.

LATEST PRICES.

Table of market prices for various materials including Iron, Steel, Zinc, Lead, Copper, Tin, and Timber. Columns list item names, units (e.g., per ton, per load), and prices in pounds and shillings.



LIST OF COMPETITIONS OPEN.

Table listing competitions with columns for project name, amount, and date. Includes entries like 'Belfast—Church and Lecture Hall at Chlorine' and 'Salford—Generating Station'.

LIST OF TENDERS OPEN.

BUILDINGS.

Large table listing tenders for buildings across various locations. Columns include location, building name, and tenderer details. Locations include Newcastle, Liverpool, London, and many others.

BUILDINGS—continued.

Barkisland—Mill	B. Taylor and Co.	A. Clement Williams, Architect, 29, Southgate, Halifax	Mar. 30
Skircoat—Villa, Albert Promenade		Chas. F. L. Horsfall & Son, Architects, Lord-st. Chambers, Halifax	31
Bolton—Fever Hospital Extensions	Corporation	R. G. Hinnell, Town Clerk, Town Hall, Bolton	31
Marsden—Additions to Lingard's Wood Bottom Schools		John Kirk and Sons, Architects, Huddersfield	31
Bridlington Quay—Additions to Holy Trinity Church		J. V. Kingsley, Marshall-street, Bridlington Quay	31
East Finchley—Mortuary Chapel at Cemetery	Vestry of St. Mary, Islington	W. F. Dewey, Vestry Clerk, Upper-street Islington	31
Llanfihangel—Additions to Board School		D. J. Lougher, Architect, Pontypool	April 1
Old Windsor—New Infirmary Buildings, &c., at Workhouse	Windsor Union Guardians	Philip Lovgrove, Clerk, 32, Park-street, Windsor	2
Leyton—Extension of Electricity Station	Urban District Council	R. Vincent, Clerk, Town Hall, Leyton	4
Barry—Additions Robially Board Schools	School Board	W. H. Lewis, Clerk, Barry	4
Halifax—Rebuilding White Horse Inn	S. Webster and Sons	Jackson and Fox, Architects, 22, George-street, Halifax	4
Ardrossan—School	School Board	Jas. Cook, Clerk, Ardrossan, N.B.	4
Bedwely—Argool School	School Board	C. Dauncey, Clerk, Tredegar	4
Droitwich—Gasworks Buildings and Plant	Corporation	S. John Tombs, Town Clerk, Town Hall, Droitwich	5
Sleaford—Foundation Works for Asylum at Ranceby	Kesteven County Council	Thos. H. Holdich, Clerk to Committee of Visitors, Sleaford	5
Aldershot—Isolation Hospital	Urban District Council	W. E. Foster, Clerk, Aldershot	6
New Brompton—Bread and Cake Bakery, &c., Gillingham-road	New Brompton Ec. & Prov. Soc., Ltd.	E. J. Hammond, Architect, 111, High-street, New Brompton, Kent	18
Belem—Cattle Pens, Abattoir, and Two Markets	Municipal Authority	The Brazilian Legation, London	July 24
Basingstoke—Shop and Assembly Hall	Corporation	R. S. Wallis, Architect, Potters-lane, Basingstoke	—
Chesterfield—Primitive Methodist Chapel	W. and M. Johnstone	W. J. Morley, F.R.I.B.A., Architect 289, Swan-arcade, Bradford	—
Carlisle—Two Villas, Dalston-road	Chas. Walker, Confectioner	Johnstone Bros., Architects, 39, Lowther-street, Carlisle	—
Colchester—Restoration St. James's Church		Chas. E. Butcher, Architect, 3, Queen-street, Colchester	—
Carlisle—Shop, Lowther-street		T. Taylor Scott, F.R.I.B.A., Architect, Carlisle	—
Littleborough—Two Shops and Slaughter-houses		F. H. Shuttleworth, Architect, Littleborough	—
Leeds—Alteration of Portion of Mabgate Mills Estate	Mabgate Mill Company	Mosley, Rent Collector, 6, Wormald-row, Leeds	—
Wadebridge—Schools		Kerley and Ellis, Architects, Exmouth and Salterton	—
Tadcaster—Enlargement of St. Joseph's	Bury Brewery Company	A. D. Kaye, Architect, 71, Albion-street, Leeds	—
Starling—Rebuilding Black Bull Inn and Cottages		Thos. Nuttall, Architect, 20, Market-street, Bury	—
Sleaford—Ten Cottages in Drove-lane	Wakeley Bros.	Jesse Clare, Sleaford	—
Otley—Thirty-one Houses		Fairbank and Wall, Architects, 3, Manor-square, Otley, Bradford	—
Maidstone—Riverside Store		Simeon Hunt, Architect, 129, Queen's-road, Brighton	—
Lowestoft—Salvation Army Buildings, Battery Green-road		Alexr. Gordon, M.S.A., Architect, 101, Queen Victoria-street, E.C.	—
Ilkley—Three Shops in the Grove		Baxendall and Critchley, Architects, The Grove, Ilkley	—
Golborne—North Aisle & Organ Chamber, St. Thomas's Church	Long Eaton W.M. Co-op. Soc., Ltd.	Heaton, Ralph, and Heaton, Architects, King-street, Wigan	—
Long Eaton—Nine Shops, Public Hall, Offices, Warehouse, &c.		Ernest S. Ridgway, M.S.I., Architect, Long Eaton, nr. Nottingham	—
Featherstone—Ten Houses		E. W. Fearnley, Featherstone Common, near Pontefract	—
Llanely—Two Villas, Old-road		J. Davies and Son, Architects, Llanely	—
Filey—Thee Shops, Belle Vue-street	H. E. Moss	Smith and Tweedale, Architects, 12, South-parade, Leeds	—
Bradford—Empire Palace Theatre, and Reconstruction of the Alexandra Hotel		W. G. R. Sprague, Fitzalan House, Arundel-street, Strand, W.C.	—
Preston Wynne—Church Restoration		G. H. Godsell, Architect, Palace Chambers, Hereford	—
Filey—Three Shops, Belle Vue-street		Smith and Tweedale, F.R.I.B.A., Archts., 12, South-parade, Leeds.	—
Selby—Factory	Inland Linoleum Co.	J. F. Walsh, Architect, Bank Chambers, Halifax	—
Llangennech—House	Working Men's Co-operative Society	J. Davies and Son, Architects, Llanely	—
Cheslyn Hay—Additions to Methodist New Connection Church		Bailey and McConnell, Architects, Bridge-street, Walsall	—
Long Eaton—Nine Shops, Public Hall, Offices, and Warehouse		Ernest R. Ridgway, M.S.A., Long Eaton, near Nottingham	—
Castle Donington—Villa and Stabling		E. R. Ridgway, M.S.A., Long Eaton, near Nottingham	—
Bradford—Detached House, Lister-avenue	Keighley Industrial Co-op. Society	F. Moore, Architect, 40, Sunbridge-road, Bradford	—
Keighley—Twenty-four Houses in Fell-lane		John Haggas, Architect, North-street, Keighley	—
Llanely—Alterations to Two Houses, Cambrian-street		J. Davies and Son, Architects, Llanely	—
Leeds—Clothing Factory in Hudson-road		Smith and Tweedale, 12, South Parade, Leeds	—

ENGINEERING.

Ballyhack—Water-Supply Works	Guardians of New Ross Union	J. Webster, County Surveyor, New Ross	Mar. 19
Oldbury—Purifier at Gasworks, Dudley-road	Gas Committee	Chairman of Gas Committee, Gasworks, Oldbury	19
Kendal—Waste Weir and Channel, Birds Park	Gas and Water Committee	T. N. Ritson, A.M.I.C.E., Manager, Gasworks, Kendal	19
Rotherham—Gas Testing Apparatus	Gas Committee	Frank A. Winstanley, Engineer, Rotherham	21
Erith—Borehole for Supply of Water	Urban District Council	Fredk. Parish, Clerk, High-street, Erith	21
Devises—Two Compound Engines (70H.P.), Wilts County Asyln.	Commissioners	Joseph T. Jackson, Clerk to Visiting Committee, Devises	21
Stromness—Water-Supply Works	Corporation	J. A. S. Brown, Town Clerk, Stromness	22
Blackpool—Electrical Plant	Urban District Council	T. Loftos, Town Clerk, Town Hall, Blackpool	22
Swinton—Precipitation Tanks	Guardians	R. Fowler, C.E., Council Offices, Swinton, Rotherham	22
Bantry—Pipe-Laying	Corporation	Richard Croly, Clerk, Board Room, Bantry	22
Southampton—Sludge Presses, &c.		George B. Nalder, Town Clerk, Municipal Offices, Southampton	22
London, E.C.—Steam and Condense Mains, &c., at City-road	Holborn Union Guardians	Harry O. Hill, Clerk, Clerkenwell-road, E.C.	23
Ballater—Concrete Filters and Boundary Walls of Reservoir		Jenkins and Marr, Architects, 16, Bridge-street, Aberdeen	23
Buncrana and Carndonagh—Execution of Railway No. 1, Co. Donegal	Board of Works, Dublin	J. Y. F. Cooke, C.E., St. Columbs, Londonderry	24
Derby—Electric Wiring at Lunatic Asylum, &c., Rowditch	Corporation	H. F. Gadsby, Town Clerk, Derby	24
Bangor—Two-Lift Gasholder	Gas Committee	John Smith, Manager, Bangor	24
Glasgow—Carpet-Beating Machine at Washhouse, Belvidere	Corporation	John Lindsay, City Chambers, Glasgow	24
Inverness—Railway Works, Fort George Branch	Highland Railway Company	Wm. Gowenlock, Secretary, Inverness	25
Birkenhead—Iron Pier, Bridge, and Floating Landing-Stage at Rock Ferry	Corporation	Alfred Gill, Town Clerk, Town Hall, Birkenhead	28
Darwen—Electrical Plant	Corporation	The Town Clerk's Office, Darwen	28
Alton—Oil-Engines and Pumps	Urban District Council	R. B. Grantham and Son, 23, Northumberland-av., London, W.C.	28
Perth—Steel Girder Bridge over River Tay	Town Council	Wm. Macleish, Town Clerk, City Chambers, Perth	28
Devonport—Widening (2½ miles) near Devonport, and Construction of Passenger and Goods Stations at Keyham, and New Viaduct over the Weston Mill Lake, Plymouth	Great Western Railway Company	G. K. Mills, Secretary, Paddington Station, London	29
Brighton—Two Reservoirs at Patcham Waterworks	Town Council	Francis J. Tillstone, Town Clerk, Town Hall, Brighton	29
Bassaleg and Risca—Widening of Line (3 miles) and New Stations at Bassaleg and Tydd	Great Western Railway Company	G. K. Mills, Secretary, Paddington Station, London	29
London, E.C.—Bridges (300ft. and 100ft. spans) and Travelling Cranes	Bengal-Nagpur Railway Co.	The Company's Office, 132, Gresham House, Old Broad-street, E.C.	29
Wetherby—Widening Leeds and Wetherby Railway (11 miles)	North-Eastern Railway Co.	H. Copperthwaite, Engineer's Office, North-Eastern Ry., York	30
Agha—Harbour	Algerian Government	M. Coustolle, Rue Mahon, No. 1, Algiers	30
Sunderland—Steel Cornish Boiler	Corporation	The Town Clerk's Office, Town Hall, Sunderland	31
Bournemouth—Motor Vehicles	Corporation	F. W. Lacey, M.I.C.E., Boro. Eng., Municipal Offices, Bournemouth	April 4
Windsor—Gas Purifier	Gaslight Co.	The Company's Secretary, 15, Victoria-street, Windsor	4
Ditchingham—Reconstructing Pirnough Bridge	Norfolk County Council	C. Foster, Clerk, Shire House, Norwich	7
Ballaclulish—Railway Extension from Connel Ferry to Balla-chulish, with Bridges across Loch Etive and Loch Creran	Callander and Oban Railway Co.	John Anderson, Secretary, 53, Bath-street, Glasgow	20
Madras—Utilisation of Water of Periyar Lake		Chief Engineer for Irrigation, Madras	July 1

FENCING AND WALLS.

Gretna Green—Inclosure Walls round Cemetery	Water Committee	M'Taggart's, Gretna Green	Mar. 21
Shrewsbury—Wrought-Iron Fencing (120 yards)		W. C. Eddowes, Borough Surveyor, Shrewsbury	25

FURNITURE AND FITTINGS.

Liverpool—Nurse's Home	Select Vestry	H. J. Hagger, Vestry Clerk, Brownlow Hill, Liverpool	Mar. 21
Lisburn—Bedsteads and Bedding	Board of Guardians	Wm. Sinclair, Clerk, Lisburn	22
Grimsby—200 Chairs, Orphan Home		Secretary, Orphan Home, Victor-street, Grimsby	—

PAINTING.

Stroud—Baths	Urban District Council	Perey Wicheh, Clerk, Russell-street, Stroud	Mar. 19
Bridlington Quay—Royal Crescent Buildings		Chas. Gray, 39, High-street, Bridlington	19
Seascale—Golf Pavilion and Caddie Shelter		H. Braithwaite, Hon. Secretary, Seascale	19
Stafford—Repainting Exterior of County Asylum	London County Council	Walker H. Cheadle, County Surveyor, Stafford	19
Kennington Park—Painting Works	Gas Committee	C. J. Stewart, Clerk, Spring-gardens, S.W.	21
Rotherham—Two Gasholders	London County Council	Frank A. Winstanley, Engineer, Rotherham	21
Bostal Woods—Painting Works	Corporation	C. J. Stewart, Clerk, Spring-gardens, S.W.	21
Bury (Lancs)—Cemetery and Approaches	Park Committee	John Haslam, Town Clerk, Corporation Offices, Bury	23
Wolverhampton—Lodge and Boathouses at East Park	Corporation	J. W. Bradley, Borough Surveyor, Town Hall, Wolverhampton	24
Durham—Baths Bridge		James Coldwell, Surveyor, Market-place, Durham	28
Westminster—Painting and Repairing Model Dwellings in Silver-place and Ingestre-place	St. James's Vestry	T. Hensman Munsey, Vestry Clerk, Vestry Hall, Piccadilly, W.	31

PLUMBING AND GLAZING.

Carlisle—Plumbers' Work to Six Houses in Beaconsfield-street	South End Co-operative Society	J. Pogson, Architect, Devonshire-street, Carlisle	Mar. 21
Rochdale—Plumbing Work at Workhouse for 12 Months	Corporation	A. Leach, Union Clerk, Union Offices, Townhead, Rochdale	23

# THE BUILDING NEWS

## AND ENGINEERING JOURNAL.

VOL. LXXIV.—No. 2255.

FRIDAY, MARCH 25, 1898.

### THE PROPOSED NEW GOVERNMENT BUILDINGS.

ONCE more the question of providing accommodation for certain public departments has been brought before a Committee of the House, and this time with greater probability of success. The scheme proposed by the Government, and detailed by Mr. Akers Douglas, as mentioned by us elsewhere, involves the expenditure of a sum of more than two millions and a half, and comprises the building of the War Office, for which £475,000 is asked; a further sum of £600,000 for the erection of the buildings on the Parliament-street site; another £100,000 for the completion of the purchase of that site, including the widening of that street; also a sum of £150,000 for the completion of the Admiralty Buildings; £300,000 for additional Post Office buildings; and lastly a sum of £800,000 for the completion of buildings for the Science and Art Department at South Kensington. From this expenditure there will be received for the spaces and areas available after the new buildings are erected a sum of about one million sterling, so that the expenditure will be lessened by nearly half. The resolution was carried by a large majority.

When it is borne in mind that a very considerable sum is paid yearly for temporary office accommodation amounting, it is said, to something like £16,000, in addition to premises on Crown land; that a large area of unused land is lying idle in Whitehall, which is valued at £10,000 rental; that, in addition, large sums have been expended in altering and fitting these temporary buildings and leasehold premises, and in appointing caretakers, office keepers, and a large staff of clerks and messenger required in carrying on the work of the department, scattered as it is in many cases over a large area, the wonder is that there has been so much delay. It is quite time that the Government took the matter in hand. The Carrington House site, Whitehall, has been a useless waste for years, besides being an eyesore in one of the best parts of London. In another case, in Charles-street, land acquired 30 years ago had been paying no interest. The Government this time means business. The purchase of Parliament-street site, and the various Bills for promoting the acquirement of the Carrington House site for the erection of the War Office, have been matters of public knowledge. Last year the Select Committee went a step further, and recommended the appropriation of sites for the different departments. The Parliament-street site was proposed for the Board of Trade and Education Department, and the extension of the Local Government Board. Now, having acquired the sites or most of them, the Committee asks Parliament for money to erect the buildings. Concentration has been found to be so urgently demanded for the despatch of business, that the building of offices on convenient sites not far from the Houses of the Legislature cannot any longer be delayed. But the question of design has yet to be decided. Are we to have a repetition of the failure of the existing buildings at Whitehall, or is there to be—as there should be—a public competition in each of these public departments? Are certain Government officials to be chosen to carry out the intentions of the committee, in conjunction with some eminent architect, or is the country to have the benefit of the talent of the whole profession?

These are questions that ought to be answered. The story told by Sir H. Campbell-Bannerman confirms the impression of all who have ever visited the new Home Office block. When that costly building was completed, it was found to be so inconveniently arranged, draughty, dark, and uncomfortable, that the officials of the War Department, on being invited to use it at first by Lord Cranbrook, on their preliminary inspection, said: "Sir, for Heaven's sake let us stay where we are, for, bad as our building is, and constructed after the manner of a rabbit-warren, we prefer it to the ghastly, uncomfortable, dark and draughty, incommensurable building which you have been good enough to offer us." The building, the same speaker said, was a scandal, and those who were housed in it, experienced public servants, could testify of the inconvenience of that structure. Dark corridors, often lighted by gas, prevail, and enormous rooms, many of them more suitable for state purposes, are set apart as offices where compactness, comfort, and warmth are demanded. The size and proportion and position of a room for an office where business is transacted are most important factors, so is light; but in the building referred to, these requirements have been disregarded, and the architect only thought of dividing up his space along the corridor into rooms of large size, and consequently much too high to suit his elevation. It is very difficult, we know, to plan a building for offices and to give it externally a palatial character; hence, it was a mistake to select a Classical or Italian style for such a purpose. It is almost impossible to make such a treatment practicable. The Classical façade demands height and dignified fenestration, and equal spacing, and every architect knows how impossible it is, without a large use of entresol arrangements, to make comfortable high rooms, or to avoid "tank rooms," or dead walling over the windows. According to Sir W. Harcourt, "each public building in succession seems worse than the last," and he gave a by no means flattering picture of the Home, the Colonial, and the Foreign Office when we are told that, even on a midsummer's day, one cannot get into the Foreign Office except through a passage lighted by gas. The new Admiralty block, bereft as it is of many of the features designed by its architects, is an exception; the rooms, as we know, are cosy and comfortable.

The outlay for the South Kensington scheme, large as it seems, is a foregone conclusion. It is a disgrace to the country that such a valuable collection should be housed, as it is, in temporary buildings of an inflammable kind. The designs for the completion of the buildings have long been in abeyance. Mr. Aston Webb's admirable design was accepted in competition in 1891; but little since has been done owing to lack of funds. The report of the Commission on Secondary Education has suggested the removal of the secretariat to the Education Office; it is also decided to remove the official residences, &c., from the Museum on the east side. These changes will enable increased accommodation for both the Science and Art Departments, and will enable an effective façade to be erected along the frontage in Cromwell-road and Exhibition-road—alterations which will require some revision of the plans.

The Post Office Savings Bank Department is also to be furnished with a new building at West Kensington. There will be some objection to the removal of this department so far west and from the City buildings; but the cost of a sufficiently large City site is one reason for the proposal, and the concentration of the Post Office buildings proper near the central office in the City is secured by this arrangement. Those intrusted with these great national

buildings have to face future expansions of the departments, and the plans for them will have to meet the need of extension.

The question that most nearly concerns the profession is the bestowal of the patronage. According to Mr. Akers Douglas, the intention of the Government is not to go to competition, because public competition has failed in the past. But why has it? The idea seems to be to employ their own official advisers to arrange the offices, and to appoint an architect for the purpose of clothing the buildings so planned. We know what such a view is worth—how often it has been tried and found wanting. It is like trying to fit a symmetrical garment to a deformed figure. Nor is it possible to produce any architecture worthy of the name under such a system? Yet it is expected of these buildings that they should "add very largely to the architectural beauty of London"!

### MODEL SPECIFICATIONS.—V.

BRICKLAYER—(continued).

WE have made a few general remarks on certain details of damp-proof walls and courses, footings, and bond in our last article, and now give a number of details which have reference to the bond of quoins and jambs (see *b*), for windows and doors, recesses and pilasters (*c*), angles of wall, bay-window bond, &c. These will explain themselves; but what we desire to emphasise is the importance of architects not only describing in general terms certain kinds of brickwork, but, when necessary, illustrating their meaning and intention by detail sketches such as those here given. The stereotyped phrases: "Carry up walls in a uniform manner, &c.," or "All brickwork to be laid in Old English bond, &c.," or "Build piers and mullions with hard, well-burnt bricks, &c.," convey very little meaning to the bricklayer as to the mode of executing the work. The bond of main and cross walls, of angles, of jambs, and reveals can only be explained by diagrams such as those given.

The importance of bond cannot be over-estimated, especially in buildings of any height, or which have to carry heavy floors, and therefore for such buildings English bond ought always to be specified. The great object of bond is to break the vertical joints; in other words, to prevent them following through more than one course at a time. For thicker walls than those of one brick, English bond is to be preferred. For heavy building or where any irregular settlement or loading is to be apprehended, hoop-iron 1 in. or 2½ in. wide and ¼ in. to 3-16 in. thick, tarred and sanded, should be used. If laid every 5 ft. or 6 ft. in height, with the courses above and below set in cement, it affords considerable strength to a wall, particularly when it is laid between the tiers of windows.

A few points in bonding deserve attention. One is the connection of main and cross walls. It is necessary that every other course should enter the thicker or main wall, as in plan (*c*), which is effected by the use of bats, as shown. Unless this is specified, bricklayers are apt to neglect the tie. The bond at window and door openings is often defective. It is necessary to insert a "closer" next the jamb in one course or to use a "king-closer" (Fig. *d*) as in the two-brick wall (plan *m*) with two closers in the jamb. Again, in forming angles of walls, acute or obtuse (see plans of those angles *i*), specially made or cut bricks ought to be used at the corners, which should be mentioned. Also in carrying up mullions for windows of bays, bond can only be secured by cutting the bricks or using special moulded ones (see plan *K*). In all these and other cases the architect should furnish a detail of the bond of two courses or give a marginal sketch, and mention ought to be



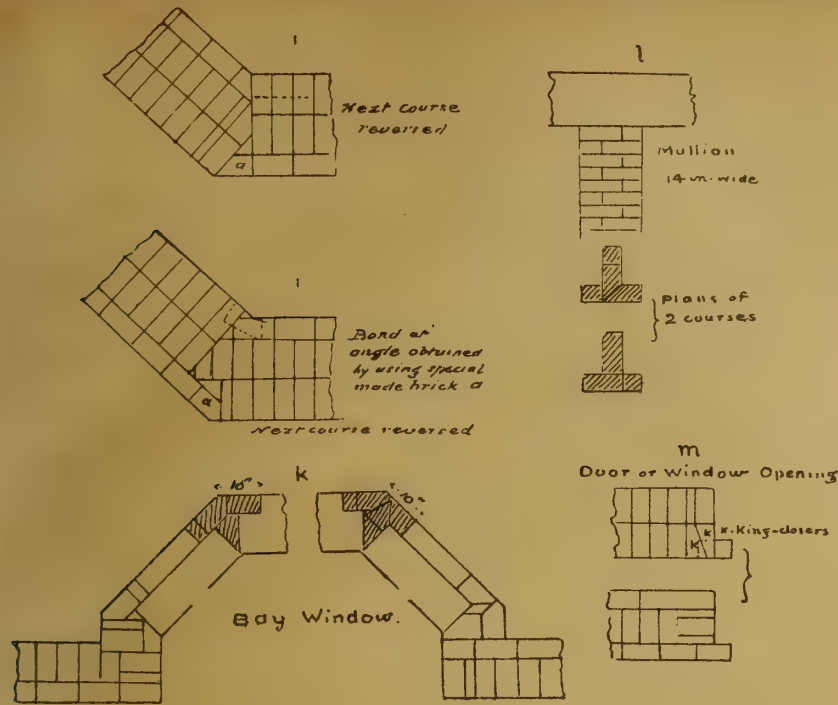

- under floor on a concrete bottom 6in. thick, with half-brick in cement sides with stone coverings.
25. *Flue Pipes.*—Line with fireclay oblong pipes (or circular) 14in. by 9in. (or 12in. by 9in. or 9in. diameter) the flues.
  26. *Stoves.*—Properly set in firebrick and cement the kitchen range, hot plates, &c.
  27. *Rake Out and Point.*—Rake out joints for flashings, and point same in cement, and to all frames. The joints to all facings where required to be raked out and weather-pointed in cement.
  28. *Glazed Brick.*—The areas (marked in plan) to be faced with Hartshill Brick and Tile Co.'s (or approved) white glazed bricks, finished with a weather joint. Or—  
Face the walls of lavatory and bathroom with cream or white glazed enamelled bricks and a dado of approved colours, and pointed in Parian or cement, with coloured joint. Or—  
Line walls of lavatory with best 3/4 in. white, cream or blue glazed tiles in 6in. squares, set in Portland cement on a backing of cement-mortar, with a dado and skirting. Or—  
Line with white glazed hanging tiles backed and bedded in Portland cement; the area walls nailed every other course.
  29. *Copper.*—Build copper with 9in. firebrick in fireclay on footings on a bed of concrete, with proper flue and ashpit, and provide and fix furnace-door and frame, with bars and damper and soot-door; and set in brickwork a strong-made copper pan, to hold 40 gallons, weighing not less than 1 1/2 lb. per gallon (or Young and Marten's galvanised iron pan and frame, p.c. 65s.); render in cement and sand.
  30. *Scully Sink.*—Provide and fix (or set) one of Doulton's (or Duckett's or Crapper's) glazed stoneware sinks, 3ft. by 2ft., p.c. 15s., on half-brick supports in cement, and pin into wall in cement.
  31. *Chimneys and Stacks.*—Build all chimney-breasts on proper footings on a bed of concrete, and parget and core all the flues, and properly bond the "withes," and make the flues airtight. The chimney-shafts and tops to be built, as shown, in cement mortar, the pots (if any) to be set in cement, and well flaunch up and weathered at top.
  32. *Parapets and Eaves.*—The upper four courses of parapets and eaves to be built in cement mortar, with red (or moulded) bricks in accordance with design. Cement fillets to be run to all gables, chimney-stacks, &c. Put tile creasing round chimney-shafts, stopped at sides in cement with Portland cement flashings. Make good after all other trades.

In connection with this trade several important rules and by-laws apply to it, which the architect must peruse before writing his specification. The London Building Act, 1894, particularly applies to external, party, and cross walls (see sections 53—81, Part IV.), and the schedules of thickness of walls relating to buildings of a private or dwelling-house kind, and those of the warehouse class, which are familiar to our London readers. Section 54, Part VI. is important, and applies to "Recesses

and Openings" made in external walls. Sub-clause (a) provides "That the backs of such recesses are not of less thickness than 8 1/2 in., and (b) that the area of such recesses and openings above the ground story do not, taken together, exceed one-half of the whole area of the wall above the ground story in which they are made. (2) Recesses may be made in party-walls, provided (a) that the backs of such recesses are not of less thickness than 13 in., and (b) that over every recess so formed an arch of at least two rings of brickwork of the full depth of the recess be turned on every story, except in the case of recesses formed for lifts; but where such recess does not exceed 5in. in depth, corbelling in brick or stone may be substituted for the arching; and (c) that the area of such recesses do not, taken altogether, exceed one-half of the whole area of the wall of the story in which they are made; and (d) that such recesses do not come within 13 1/2 in. of the inner face of the external walls. (3) An opening shall not be made in any party-wall, except in accordance with the provision of this Act in relation thereto." These requirements may be modified in certain cases, and the superintending architect (on application made to him) may consent to any modification or relaxation of this section, in respect to the area of recesses and openings in special cases.

ROYAL INSTITUTE OF BRITISH ARCHITECTS.

THE tenth ordinary meeting for the present session of the Institute was held on Monday evening, and was very numerously attended. The president, Professor George Aitchison, R.A., occupied the chair.

THE NEW GOVERNMENT OFFICES.

Mr. WILLIAM WOODWARD asked whether any communications had passed between the Council and Her Majesty's Office of Works, with reference to the designs for the proposed new Government Offices in Whitehall? The PRESIDENT replied that communications had passed; but as at present they were strictly confidential, he could give no information on the subject. Mr. WOODWARD asked whether, as members of the Institute were not all able to attend the meetings, but were scattered over the United Kingdom and the Colonies, an official intimation of the nature of the correspondence might appear in the next issue of the Institute Journal? (Several voices: No, no.) The PRESIDENT said that until the people who had asked them to regard these matters as confidential requested them to make

them public, they would be unable to publish them.

PRESENTATION OF MR. PENROSE'S PORTRAIT.

The PRESIDENT then requested Mr. Alma Tadema, R.A., to formally unveil and present to the Institute on behalf of the subscribers a portrait of their late President Mr. F. C. Penrose, who was so well known throughout all the world for his discovery of the optical refinements which governed Greek architecture. The subscribers had been so fortunate as to get Mr. Sargent to execute the commission, and having seen the portrait, he would only say it was well worthy to be hung alongside those they already possessed, executed by J. P. Knight, William Boxall, George Richmond, Frank Holl, and their distinguished honorary Associate, Alma Tadema.

Mr. ALMA TADEMA said he regarded it as a great privilege to be called upon to unveil the portrait of a man he esteemed so highly painted by a man whom he esteemed no less. They recollected that during his term of office Mr. Penrose was called upon as the English member of an international commission of three architects to revisit Athens and advise as to what steps should be taken to save the Parthenon from further damage after a seismic disturbance. To have had such a president was an honour to the Institute, and to possess such a portrait of him added very much to the collection, which, he would venture to suggest, were worthy of being hung in a special gallery. [Hear, hear.] Mr. TADEMA then, amid general applause, unveiled the portrait, which depicts Mr. Penrose at nearly full length. He is reported as seated in a high-backed armchair, with head slightly raised, and looking almost directly forward; the knees are crossed, and the hands folded just above them. On the right of the chair is a portfolio of drawings. The general expression of opinion afterwards was highly favourable.

The PRESIDENT referred at some length to the investigations and measurements carried out in Athens by Mr. Penrose for the Dilettante Society, which established for all time the truth of Wilkins's surmise as to the proper reading of the passage in Vitruvius as to the optical refinements in the lines of the buildings adopted by the Greeks. He proposed a vote of thanks to Mr. Sargent for the admirable portrait he had given them.

Mr. J. S. SARGENT, R.A., who spoke with obvious diffidence and embarrassment, briefly replied.

HERALDIC DRAWING AND ITS ADAPTATION.

Mr. JOHN D. CRACE, Hon. Associate, read a paper on this subject, illustrated by a number of original cartoons by well-known architects, and by drawings, tracings, and photographs of Mediaeval examples, specimens of book-plates, and a magnificent Spanish cloth of State, heavily embroidered in gold. He mentioned that in the drawing of heraldic devices, one leading principle applied—the necessity of recognising what has to be said, and how to say it simply and directly. The heraldic device was intended to appeal, not to the sensibilities or emotions, but to a simple intelligence, to be rapidly understood. The eagles, lions, roses, or fleurs-de-lys of heraldry were not to be thought of as pictorial illustrations of the animal or vegetable creation, nor even as emblems, but as symbols. The conventional or symbolic representation of the heraldic "charge" conveyed certain limited information at a glance. Heraldry had been described as "out of date," "antiquated nonsense"; but modern equivalents for the heraldic "ordinaries" might easily be found. The effigies painted on tavern signboards showed at once the name and purpose of the house; the colours of the jockey's jacket conveyed distinct information; flags, whether for signalling or for distinction, were actually heraldic. The lecturer cited instances of the ease with which facts about people dead centuries ago could be learned from the heraldry displayed on relics associated with them which had come down to the present day. In decorative heraldry, whether architectural or other,

EXTREME CLEARNESS OF EXPRESSION

is required; the more so since frequently the examples are distant from the eye, or in positions where other forms more important to the composition must be so rendered as to claim the first attention. The details have also sometimes to conform to cramped and difficult spaces, such as spandrels or glass inclosed by intricate tracery. Allusion was made by the lecturer to the close relationship between the symbolic design of

heraldic charges, and the less direct forms used in expressing ideas by writing. Looking back to the remote times of Egyptian art, each of the kings and queens of the various dynasties could be distinguished by the "cartouche" bearing the symbols of that sovereign. That "cartouche," repeated on the cornice of a temple, was almost as heraldic as the shield repeated on the cresting of an English monument, and its object was virtually identical. The animal devices used as symbols on Egyptian monuments of 3,000 years ago had never been surpassed, and should be well studied by the heraldic draughtsman. Though used to convey the sense of words or sounds, they were also used to convey certain information even when writing came into general use. For monumental purposes the well-recognised symbol conveyed the idea more promptly. It is of primary importance that the object representing the idea should be so drawn as to be promptly recognised; and the art of conventionalism is the art of selecting the most characteristic points, leaving details to be filled in or not according to circumstances. Having shown under what conditions it was permissible to multiply or omit details, and when "naturalism" or fanciful treatment might be indulged in, provided the object represented was as far as possible unmistakable, the lecturer went on to speak of heraldic draughtsmen of the last fifty years who had successfully grasped the problem of sound conventional drawing as applied to heraldry, selecting for mention the names of those deceased—Willemont, Pugin (some of whose original drawings for the heraldic glass in the Houses of Parliament, lent by Messrs. Hardman and Powell, were exhibited in the meeting-room), John Powell, James West, Clement Heaton, and William Burges, all in their several ways real artists. So far as heraldic art was concerned, Pugin was *facile princeps*. In point of design and arrangement, his heraldic glass at Westminster was without equal. The lecturer then exhibited a model, and dealt with the relations between the helm, the crest, the wreath or torse, and the mantling, describing and explaining the origin and purpose of the various parts, and some methods of treatment.

#### CONTINENTAL HERALDRY.

Touching heraldry abroad, the Germans had always maintained a love for heraldic device; and the principal front of the new Parliament House in Berlin is ornamented with two fine heraldic panels, in which the shields are combined with sculpture of very high artistic merit. In Spain heraldry was freely used for the decoration of architecture—there were notable examples at Burgos and Toledo. Magnificent cloths of State, embroidered with the arms and badges in gold and colour on silk or velvet grounds, were also in use in Spain. Such decorations, the lecturer considered, might be introduced into municipal and other public ceremonies in our own days. A really fine heraldic cloth would make a much more imposing background to a royal or municipal group than the extemporaneous and tawdry finery ordinarily the expedient on such occasions, and the cost, in the long run, be less than what is now expended spasmodically on temporary rubbish. As examples of the valuable decorative effect of heraldry in architecture, the lecturer instanced the blazoned shield in the boss at the intersections of rib-vaulting, or on the hammer-beam of a timber roof, or in some of the high chimney-pieces illustrated in the paper read a year since by Mr. J. A. Gotch. Having summed up the essentials necessary to good heraldic designing, the lecturer, in conclusion, read some notes by Mr. George W. Eve, author of the recently-published work on "Decorative Heraldry." These touched upon the influence of architecture on heraldic designs in book plates, perceptible from the very earliest examples; the value of the panel as a basis of design, as shown in the works of Sebald Behem, Virgil Solis, and others; the extensive use of architectural details in the armorial work of Albert Dürer and his school, and in the elaborate compositions of Jost Amman; and the modifications in treatment the armorials have undergone by the influence of the sculptures and coats-of-arms represented in high relief.

Mr. J. ALFRED GOTCH, in proposing a vote of thanks to the lecturer, observed that there had been of late years a revival of interest in heraldry, and it was most desirable that architects should be in a position to draw the charges and mantling clearly and correctly. He did not himself revel in a multiplication of quarterings,

but admired a simple and legible rendering of family arms. Architects and the public generally were largely in the hands of the officials of Herald's College, and it was satisfactory to see some improvement in recent grants on the absurd and unartistic arms granted 90 years ago. They might hope for still greater improvement in the future in the training of these officials. One paramount quality was necessary in heraldic draughtsmanship—vigour. All the animals displayed in heraldry, with one doubtful exception, the mermaid, were masculine, and should possess the virility of their sex. The heraldic artist had to study how to impart interest and beauty to subjects which were comparatively tame. It was easy to draw an interesting lion or even a vigorous pig—an example of which by Pugin could be seen on the wall; but when they came to draw a porridge-pot or a wheel then difficulties began. On the great Spanish cloth of State hung on the wall they would see an excellent treatment of this very object (a wheel) in perspective. As to the mantling, Mediaeval designers recognised and emphasised the fact that the material had two sides of different colours. With regard to book plates, many had been designed of recent years, and in some of them legibility was sacrificed to beauty. Modern heraldic drawing might be quite distinct from Mediaeval examples, and yet very effective.

Mr. W. H. ST. JOHN HOPE seconded the vote of thanks, remarking that Mr. Crace might give them a second paper on Badges and their treatment. Mediaeval heraldic artists revelled in the drawing of badges, and Pugin fully appreciated their value for decorative purposes.

Windsor Herald (Mr. W. A. LINDSAY) said the lecturer and Mr. Gotch had been rather hard on the College of Arms. He conceded that years ago grants were made of arms which were absurd; but the fault was that the officials of the College of Arms were then too willing to give individuals or the public what they demanded. He must defer to Mr. Gotch's suggestion that in book-plates the name ought to be clearly printed—if heraldic emblazonment was worth anything at all it set forth the name as distinctly as if it were written.

Mr. WILLIAM WHITE, F.S.A., having supported the vote of thanks, the PRESIDENT, in putting the motion, observed that heraldic drawing was one of the most becoming subjects to be treated of before architects, for, according to Addison's mistranslation of one of Martial's epigrams:—

If of dull parts a stripling you suspect,  
A herald make him, or an architect.

Mr. CRACE, in reply, said he concurred with Mr. Gotch that vigour was essential in heraldic drawing. The subject of Badges, suggested by Mr. St. John Hope, would make an interesting paper of itself. The College of Arms shared in the general decadence of taste on the part of the public in the first part of the century, a fault from which they were not altogether free in the second half. He was sorry he could not support the contention that the owner's name should never be added to the coat of arms on book-plates. If they examined the stall-plates of the Knights of the Garter in St. George's Chapel, Windsor, they would see that the names of the holders were engraved on many of the earliest plates.

#### ELECTRIC LIGHTING NOTES FOR ARCHITECTS.—XIX.

By AN ASSOC. INST. ELECT. ENGS.

MEASURING INSTRUMENTS AND TESTING.

BEFORE leaving the subject of ammeters and current measurement it will be necessary to refer to a class of instrument quite distinct from those already considered, much used for standardisation purposes. These instruments are known as *electro-dynamometers*, since the working of them depends upon the mutual attraction and repulsion of two adjacent current-carrying conductors, and not upon the magnetisation of iron; the determination of current strength with these instruments, in fact, depends upon the measurement of the mechanical forces existing between the adjacent coils traversed by a current or currents. Weber was probably the first to draw attention to the fact that this class of instrument was specially adapted for making accurate measurements, and both Siemens and Lord Kelvin have introduced modern instruments

depending upon the dynamical forces set up by adjacent currents. And, as Siemens' electro-dynamometer is a good example of this type of instrument, we shall consider this particular instrument to illustrate the principles underlying the action of the electro-dynamometers generally. A diagrammatic sketch of the working-parts of a

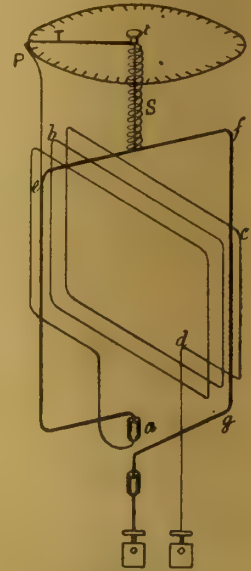

FIG. 67.

Siemens electro-dynamometer is given in Fig. 67, whilst the complete instrument is shown in Fig. 68.

As will be observed, the instrument consists of two rectangular coils, connected in series with each other. One of the coils, *abcd*, is fixed permanently to the framework, whilst the other, *efg*, which is movable, and consists of one or two turns, is suspended by a silk thread and a spiral spring *S*. Siemens' electro-dynamometer is, therefore, an example of a spring-control ammeter, the needle of which is replaced by the suspended coil. In the normal position the plane of the movable coil, *efg*, is at right angles to the plane of the fixed one, the latter being placed within the former, so that their centres coincide.

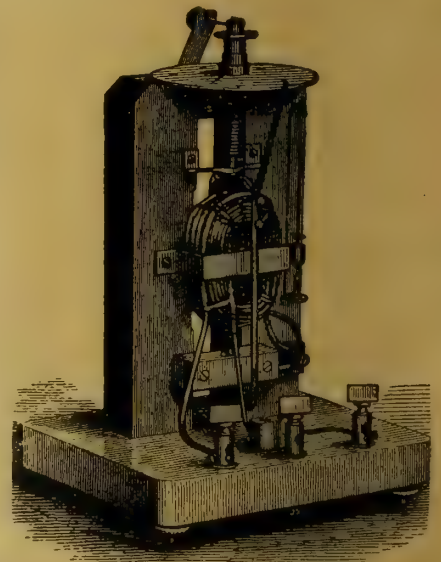

FIG. 68.

To enable the same current (which is the one to be measured) to pass through the two coils they are connected together in series by means of mercury cups, and the suspended coil is therefore perfectly free to move round the vertical suspension when the current passes. The normal position of the movable coil is indicated by a pointer, *P*, pointing to the zero point of a scale fixed at the top of the instrument. This pointer is attached to the movable coil, as shown, and the movement of this pointer, and therefore that of the coil, is limited

by two small pins, *pp*, projecting from the edge of the disc on which the scale is marked, one pin being on either side of the scale zero. A plan of the disc, scale, pins, pointer, torsion-index *T*, and torsion head *t*, is shown in Fig. 69.

Before using the instrument, it should be placed so that the plane of the fixed coil coincides with the earth's magnetic meridian, in which case the earth's magnetism cannot produce any deflecting effect on the movable coil, and the instrument should also be carefully levelled. It will also be observed that the upper end of the spiral spring is attached to a milled torsion head, marked *t* in Fig. 67, to which is also attached a torsion index *T*, to indicate the angle of torsion given to the spring. Should this torsion index not point to the zero point of the scale when the movable coil is in its normal position and no current is passing, the torsion index may be turned without twisting the spring or turning the milled head *t* by loosening a small pinching screw which clamps the torsion index to the milled head, and in this way the torsion index and pointer may be made to point to the same point without giving torsion to the spring.

On sending a current through the instrument, the movable coil tends to place itself parallel to the fixed one—i.e., so that their axes are parallel, in which case the magnetic fields due to the current traversing both coils would be coincident; but this is prevented by the two pins *pp*. In consequence of the arrangement and interconnection of the coils, the direction in which the suspended coil tends to rotate is counter clockwise,

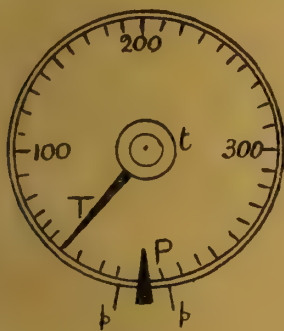

Fig. 69.

and by turning the torsion index in the clockwise direction through a certain angle sufficient torsion is given to the spring, so that the couple exerted by it just balances the couple exerted between the current-carrying coils, and the movable coil is brought back to its initial position—i.e., the pointer *P* points to zero. Now, the action between two adjacent current-carrying coils traversed by currents is mutual, and the couple is simply proportional to their magnetic moments, and therefore to the product of the currents passing through them. Moreover, the moment of the couple exerted by the spring is simply proportional to the angle through which the torsion index is turned, or, in other words, to the angle of torsion, and it is thus clear that the angle of torsion is a measure of the square of the current, since the same current passes through each coil. Hence the value of the current is given by the formula:

$$C = K \sqrt{\theta},$$

Where *C* = the current in amperes.

*K* = a constant depending on the construction of the instrument and the spring used, and which may be determined by experiment.

$\theta$  = the angle of torsion when equilibrium exists between the two couples. In other words, it is the torsion which must be given to the spring to keep the suspended coil at zero.

In order to increase the range of this instrument, or, in other words, to enable the same instrument to measure currents differing considerably in magnitude, each instrument is provided with two distinct and separate fixed coils. One of these consists of a few turns of thick wire, and is used for the measurement of heavy currents, whilst the other, consisting of five times as many turns of finer wire, is used for the measurement of smaller currents. To use either of these coils as may be desired, the instrument is provided with three terminals, the middle one being a common connection to both coils. With each instrument there is supplied a table of values, giving

the magnitude of the current corresponding to each division of the scale, so that the current is determined directly without making any calculation. The electro-dynamometer may be used for alternating currents, as well as for continuous currents, and this, it will be observed, is a great advantage.

**Voltmeters.**—We have already pointed out how essential it is that the proper electrical pressure should be generated and maintained in a circuit supplying energy for lighting purposes. It is,

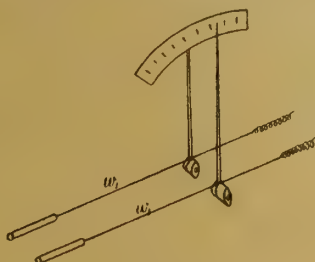

Fig. 70.

therefore, a matter of much importance to be able to determine readily the pressure between different points in a circuit, and for this purpose voltmeters are used. In the majority of the voltmeters used the electro-magnetic principle is employed, and the working parts and construction are identical with those explained under the head of ammeters in Article XVIII. As a matter of fact, electro-magnetic voltmeters are ammeters calibrated to indicate electrical pressures. When we remember that, according to Ohm's Law,

$$C = \frac{E}{R},$$

it will be obvious that if *R* is constant, the current *C* will be proportional to the pressure *E*, sending the current through the resistance *R* of the instrument—that is, the deflection produced by the current is a measure of the electro-motive force at the terminals of the instrument. It must, however, be pointed out that ammeters depending on electro-magnetic action are low-resistance instruments, being usually wound with few turns of thick wires, so as not to produce any appreciable loss of pressure, from which it is clear that voltmeters should be high-resistance instruments; they are therefore wound with many turns of fine wire, and this is practically the only difference in the construction of voltmeters and ammeters of this class of instrument. At the same time it is essential that voltmeters should not waste an undue amount of energy, and fortunately very little current—only a fraction of an ampère—passes through the instrument; and, unlike ammeters, voltmeters are connected across the mains of a circuit—i.e., between the points

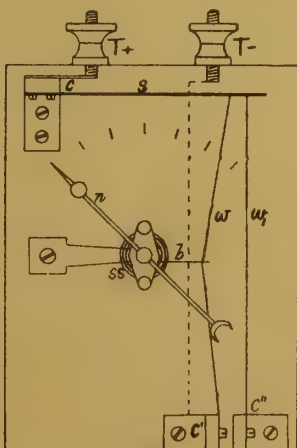

Fig. 71.

between which we desire to determine the pressure, and not in the main circuit. This is, of course, connecting the voltmeter as a shunt across the part of the circuit to be measured. So far no mention has been made of instruments depending upon the heating effect of a current, although the temperature of a wire traversed by a current is always raised to a greater or less degree, the amount of heat which is produced being

readily calculated by means of the formula  $H = C^2 R t \times 0.24$ , in which *H* is the number of units of heat (calories) developed, *C* the current in amperes, *R* the resistance in ohms and 0.24 is a constant connecting these quantities together. From this formula it is obvious that hot-wire instruments are altogether unsuitable for use as ammeters, since ammeters are traversed by the full current. As voltmeters, however, hot-wire instruments possess certain advantages. The currents passing through them are small, and since it is desirable they should have considerable resistance fine wire may be used, in which case an increase of temperature results with very little loss of heat, and the accompanying expansion of the wire produces sufficient elongation to indicate the magnitude of the current passing, and therefore the electro-motive force sending the current through the wire. They are, moreover, specially adapted for measuring alternating currents, and the same hot-wire instrument may be used on both direct and alternating current circuits. There are, however, several sources of error in hot-wire instruments, and the following descriptions explain how these instruments may be made reliable.

In Fig. 70 a diagrammatic figure is given of



Fig. 72.

one of the earliest practical forms of hot-wire instruments introduced by Mr. G. M. Hopkins. As will be observed, there are two fine wires, *w* and *w*<sub>1</sub>, and these are exactly similar and of the same material. The wires are arranged as shown, so that the one *w*, which carries the current, will move the index finger when expansion occurs, whilst the other, *w*<sub>1</sub>, which is not traversed by the current, moves the dial should expansion occur. This arrangement compensates for all variations of the temperature of the surrounding air, so that the actual reading indicates the difference of the temperatures of the two wires, and not on the absolute temperature of *w*. The difference between the temperatures of the two wires is obviously due to the current passing through *w*, and in this way the expansion of this wire enables the current to be measured.

Another interesting hot-wire voltmeter, known as a cell-tester, and introduced by Holden, is shown in Fig. 71. Since the E.M.F. given by a single secondary cell or accumulator varies from 2 to 2.5 volts, this instrument has been designed to measure small pressures. From the figure it will be observed that two fine wires, *w* and *w*<sub>1</sub>, of the same material and size, are connected to a spring, *S*, fixed horizontally at the top of the instrument, and to two separate angle-pieces, *C* and *C'*, fixed at the bottom of the instrument, and *C'* is insulated. *C* is connected by means of a conductor (shown dotted) to the terminal marked (*T*—). The spring *S* is supported by the angle-piece *C*,

which is connected directly to the terminal (T+). It is thus evident that only the wire *w* can be traversed by a current, the second wire *w*, being introduced to compensate for variations of the temperature of the surrounding air. Since both wires are stretched tightly between the spring S and the angle-pieces C and C', any sag in the two wires resulting from expansion due to variations of temperatures externally, will be taken up by the spring S, and the needle of the instrument will not be affected. But when the wire *w* is heated by the passage of a current through it, it expands more than *w*, and a certain amount of sag results. This is taken up by the hair-spring *ss*, and the bar *b* connected to the wire *w*, and the needle *n* is free to rotate a certain amount. Since the spring S is prevented from taking up any of this sag, in consequence of the tension of the wire *w*, it is clear that the controlling force of the instrument is supplied by the spring S. The arrangement of the hair-spring *ss* and the needle *n* is such that the needle tends to rotate. But this is not possible under normal conditions, and the deflection of the needle is a measure of the difference of the temperatures of the wires, and therefore of the current passing along *w*. The current passes from terminal to terminal along the spring S and wire *w*. The needle may be adjusted to zero by means of a small thumb-screw.

The chief of the hot-wire voltmeters is that of Cardew's, shown in Fig. 72. In this instrument a long length (13ft.) of fine platinum-silver wire—0.0025 of an inch, or 2½mils. in diameter—is used. This wire is fixed at one end to a small fixed brass block, *b*, from which it is led round a grooved insulated pulley fixed at the other end of the brass tube. It then returns, and passes round a small insulated pulley, *c*, and back again to pass round a second grooved insulated pulley at the end of the tube, finally terminating at the brass block *b*. These blocks are insulated from the case by pieces of vulcanised fibre, and are also connected to the two terminals of the instrument by pieces of copper wire, as shown. The spindle carrying the two pulleys at the end of the brass tube is pivoted in jewelled holes, so that the friction is reduced to a minimum, and it is necessary that the wire should pass round these two pulleys in such a way that they rotate in the same direction when the sag is taken up by the movement of the pulley C, which does not rotate. The pulley C, it will be observed, is attached to a brass strip, which is connected by a fine platinum-silver wire to the spiral spring S. This spring keeps the wires stretched tightly, and the tension of the spring may be varied by means of the adjusting screw S<sub>c</sub>. When a difference of potential is maintained between the terminals of the instrument, a current traverses the platinum-silver wire, and since the resistance of this wire does not vary greatly, the current is proportional to the pressure maintained at the terminals. The current raises the temperature of the wire, which expands, and since the wire is very thin, the temperature corresponding to the current passing is quickly attained and very little heat is lost. The elongation produced is taken up by the spring S, which pulls down the wire (passing round the double-grooved wheel W) connected to the pulley C, and the wheel W turns on its spindle, which also carries a toothed wheel geared into a small pinion. Attached to the spindle carrying this pinion, but in front of the instrument, is the pointer capable of moving over a dial graduated in volts, and the gearing is so arranged that for a small elongation of the wire there is considerable movement of the pointer. A moment's consideration will suffice to show that the movement of the pulley C is due to the expansion of only half the total length of the wire used. The same result would be produced if only half the total length of fine wire were used; but there is the advantage that by using the greater length of wire the section may be smaller (for the same spring S), so that the fine wire heats and cools more rapidly than a thicker one, and the voltmeter is more dead-beat in its action.

In addition to the advantage of being able to measure the pressures of alternating currents as well as those of continuous currents, this instrument possesses the advantage of having no heating error, inasmuch as the heating effect of the current is the property utilised. It, however, absorbs a good deal of energy, and cannot be used for measuring small differences of potential.

(To be continued.)

SANITARY WORK.—II.

WATER-WASTE PREVENTERS.

FLUSHING appliances for water-closets, urinals, housemaids' slop-sinks, &c., can be obtained in almost endless variety, and it is therefore necessary to exercise a certain amount of discrimination in their selection.

In most towns the water company make it



FIG. 12.



FIG. 13.

compulsory that the flushing apparatus to a water-closet shall take the form of what is known as a "water-waste preventing cistern," and frequently will only permit certain approved patterns to be used. The discharging capacity of the waste-preventer is also generally limited to two gallons on each occasion that the closet is flushed with water.

As a general rule the waste-preventing cistern is placed directly above the closet at a height of 7 or 8ft. from the floor. The 1½in. diameter lead flushing pipe should be connected to the flushing arm of the closet by means of a stout indiarubber cone, and well secured with copper wire. Illustrations of the indiarubber cones or connectors used for this purpose are seen in Figs. 12 and 13.

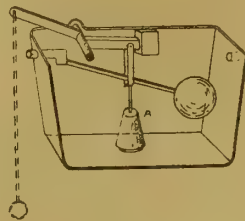

FIG. 14.

The former being known as a "straight" cone, and the latter as a "bulged" cone.

Waste-preventing cisterns are broadly divisible into two classes—viz., those which depend for their action on the opening or closing of one or more valves, and those which are entirely valveless. The contents of the latter description are usually arranged so as to be discharged by siphonic action on pulling a handle.

Before referring more particularly to the siphonic action flushing cisterns or water-waste preventers, which are now so largely used, the class of flushing cistern in which the supply of water to the closet or other fitting is regulated by one or more valves will first be noticed.

Fig. 14 is an illustration of what is known as a "single-valve waste-preventing cistern." On pulling the handle, the dead-weight valve A is raised so that the water within the cistern rushes

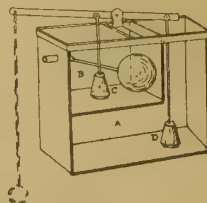

FIG. 15.

down the flushing-pipe and flushes the closet-basin. It will also be observed that by the same action of the lever the ball-valve is closed, so that should the cistern handle be held or fastened down, only the contents of the cistern (generally about two gallons) can be discharged, and no more water will be supplied until the handle is released and the dead-weight valve closed.

For the purpose of emptying cisterns of this description, and so obtaining the maximum flush which they provide, it is absolutely necessary to hold down the handle during the whole time.

The result is that in the majority of cases where this type of waste preventer is used, the closet basin is insufficiently flushed, as the volume of water passing during the short time the handle is held is quite inadequate to properly remove the faeces and paper from the drains. Such an economical use of water may be advantageous to the water company, provided the cisterns continue in good working order; but, on the other hand, should the apparatus be in any way defective, a very serious waste may take place without being noticed or remedied for a considerable time. For instance, if the valve does not sit tightly upon its seating, a small stream of water will be continually running through the flushing pipe, probably quite unobserved.

The flushing cistern shown in Fig. 15 is known as a "double-valve waste-preventer." The cistern is divided into two compartments, A and B, one of which is connected directly with the flushing pipe, whilst the other contains the ball-valve. An opening is arranged between the two chambers, which is governed by the dead-weight

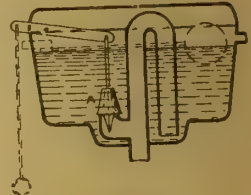

FIG. 16.

valve C. The water supply to the flushing-pipe is regulated by means of the valve D. When the cistern is not in use, both chambers of the waste-preventer are full of water. The apparatus is so arranged that when the handle is pulled the valve D is raised whilst that at C is tightly closed. So long as the handle is depressed, the water from the compartment B passes down the flushing-pipe to flush the closet-basin; but no further supply of water can pass from the chamber A until the handle is released. When this takes place the valve D is closed, and that at C is opened, so that the chamber B is again quickly filled with water. These waste-preventers are subject to the same disadvantages as those already mentioned in connection with single-valve waste-preventing cisterns.

It will be observed that neither the single or the double-valve waste-preventer shown can be

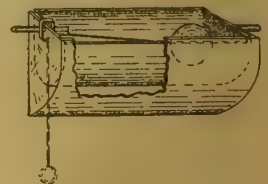

FIG. 17.

used with valve closets, as no "after-flush" is provided in order to recharge the basin with water when the closet valve is closed. Attempts have been made to overcome this difficulty by providing an additional small chamber or box at the bottom of the waste-preventing cistern, and which is known as a "trapping-box." The trapping-box is so designed as to retain a small quantity of water (about half a gallon) when the cistern is being discharged, and afterwards to allow the retained portion to slowly trickle down the flushing-pipe and remain within the closet basin. Should, however, the handle be held up too long, the dribble of water intended for the after-flush runs away, and the closet basin is left quite dry.

Another form of valve waste-preventing cistern which provides a distinct after-flush is also sometimes used. In this instance the cistern is divided into three compartments, and arranged with four separate valves. In one compartment the ball-valve is placed; whilst the other two respectively contain the specified quantity of water required for the flush and after-flush. When the handle is raised, the water within the flushing compartment is discharged; but no further allowance of water can pass into the basin until the handle is returned to its normal position. The water retained within the after-flush compartment is then immediately discharged to provide the necessary



pool within the basin. Waste preventers of this latter description are, however, far too complicated for ordinary purposes, and are constantly liable to get out of order, besides being difficult to repair.

Many descriptions of water waste-preventing cisterns are provided with a valve so arranged as to set up siphonic action, and thus rapidly discharge the entire contents of the cistern without the necessity of holding down the handle

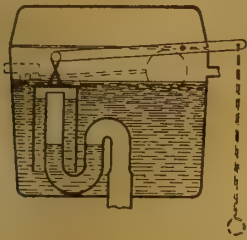

Fig. 18.

during the whole period of discharge. Fig. 16 is a sketch of a waste-preventing cistern of this class. When the handle is pulled, the dead-weight valve A is immediately raised, so that a quantity of water rapidly passes down the flushing pipe and at the same time withdraws the air from the discharging leg of the siphon. By this means siphonic action is directly set up within the siphon, and a full and complete flush is obtained. As in the case of all cisterns provided with valves, a great waste of water may take place, should the valve at any time become worn, or sit improperly upon its seating.

Numerous varieties of *valveless* water-waste preventing cisterns—good, bad, and indifferent—have been introduced from time to time, most of

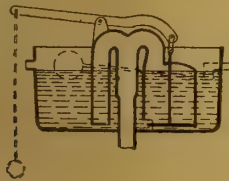

Fig. 19.

which utilise the principle of siphonic action in one way or another. For water-closets and housemaid's slop-sinks, this action is generally put in motion by simply pulling a lever or handle; but for urinals, &c., the waste-preventers are more frequently arranged to discharge automatically at regular intervals.

In addition to the various siphonic action water-waste preventers now in the market, there is another type of *valveless* waste-preventing cistern manufactured to which a brief reference may be made. These are known as "tipping," or "revolving water-waste preventers." The general principle of construction is indicated in Fig. 17. A small revolving basin or "tipping box" is accurately pivoted inside the ordinary cistern, which is filled with water by means of the usual ball-valve. On pulling the handle, the

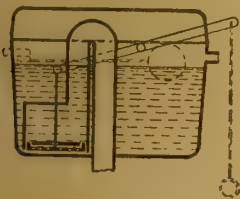

Fig. 20.

tipping box is overturned, so that the water is discharged into the outer cistern, and from thence into the flushing pipe.

*Automatic revolving water-waste preventers* may also be obtained, in which the tipping-box is so arranged that directly it is full the weight of water overturns it and the contents are immediately discharged. They may be fed by the smallest dribble of water. *Revolving water waste-preventers* are, however, not much used, as the noise and splashing of water renders them objectionable.

Fig. 18 shows a well-known form of *valveless siphonic-action* cistern or waste-preventer. It consists of a siphon provided with a trapped arm, the lever or handle being attached to the movable cap, as indicated in the sketch. By pulling the handle the cap is raised, together with the water contained within the annular space, which, falling in comparatively large volume down the vertical pipe, starts siphonic action and rapidly discharges the contents of the cistern.

Some water companies insist upon the crown or bend of the siphon being so arranged as to be *above* the level of the top of the cistern, so that any risk of the water wasting and dribbling away unobserved through the siphon itself may be entirely prevented. Under such circumstances, the waste-preventer just described cannot be used.

Figs. 19, 20, 21, 22, and 23 are typical illustrations of *valveless* water-waste preventing cisterns in which the crown of the siphon is placed *above* the level of the top of the cistern. In each case it will be seen that a quantity of water is in the first instance mechanically forced through the siphon in order to start the siphonic action. They are accordingly sometimes known as "displacer-started siphonic-action cisterns." The different means adopted for mechanically

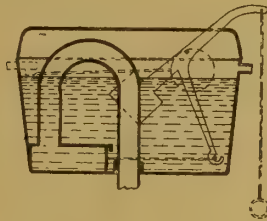

Fig. 21.

displacing the water, so as to bring the siphon into action, will be readily understood on reference to the illustrations. In Fig. 19, the act of pulling the handle lifts the plunger (or water displacer) attached thereto, and forces a quantity of water into the descending arm of the siphon, bringing it immediately into action.

A modification of the same mechanical movement is shown in Fig. 20. The water is first lifted over the crown of the siphon by means of a loose metal disc, and the siphonic action started.

Fig. 21 illustrates a water waste-preventer, in which the plunger is given a horizontal movement. This is connected to the handle by means of a cranked lever weighted at one end.

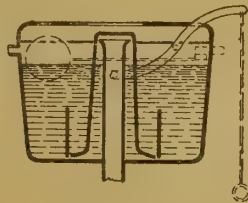

Fig. 22.

Pulling the handle, the plunger is thrust forward, driving the water before it into the siphon, and so setting it in action. The plunger remains in this position until the contents of the cistern are discharged, when it returns to its original position, being forced back by the weighted lever attached thereto.

The *valveless*, siphonic-action waste-preventer shown in Fig. 22 is illustrative of what is known as the "pull-and-let-go" type. When the handle is depressed, the movable cap of the siphon is raised; but the water within the annular space is not lifted, owing to the absence of any trap or seal on the outlet or discharging arm of the siphon. As a consequence, so long as the handle is held down, siphonic action cannot take place, nor can any water escape; but directly it is released the cap descends (in consequence of its weight) and forces the water before it into the discharging arm, thus setting up siphonic action.

Another arrangement is shown in Fig. 23. In this case the cap, when in its normal position, is raised to a certain level by means of a weighted lever. On pulling the handle the cap is forced downwards into the well in which it works, the water being at the same time driven into the long arm of the siphon in sufficient volume to start it.

When ordinary siphonic action water-waste preventing cisterns must of necessity be fixed near living or bedrooms, they are frequently found to be very objectionable on account of the loud gurgling noise which occurs at the conclusion of each siphonic discharge. This is due to the siphon drawing in both air and water towards the end of the action. Under such circumstances the closet cannot be used without

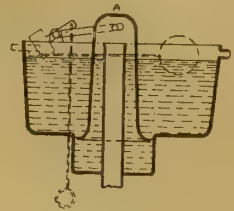

Fig. 23.

the fact being made perfectly audible to every person in the immediate vicinity. To remedy this defect, various contrivances have been designed. Amongst others that might be mentioned, the waste-preventer just illustrated (Fig. 23) can be obtained with a noiseless arrangement. A valve with a weight and float is attached to the cap or dome of the siphon at A. When the cap is pulled down in order to start the siphonic action, the weight keeps the valve closed; but when the water-level in the cistern falls below the float, the valve is opened, and air is admitted into the top of the siphon, thus preventing the noise which would otherwise be caused by drawing in air and water at the bottom.

*Automatic flushing cisterns* are usually provided to urinals, latrines, &c., and may be obtained in great variety. As regards the general principles of construction, they are practically the same as

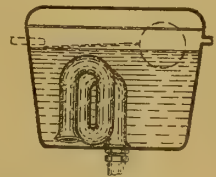

Fig. 24.

those of larger size, which are used for flushing drains. The action of the automatic siphonic flushing-cistern, shown in Fig. 2, has already been explained.

Fig. 24 is the sketch of another well-known automatic siphonic-action flushing-cistern. Essentially, it consists of a siphon with a trapped arm, so arranged that immediately the water-level attains a sufficient height, or head, above the crown of the siphon, the confined air is forced out and siphonic action set up. A reversible ball-valve must be used with this cistern; in fact, it is a safe general rule to provide a reversible ball-valve to all automatic siphonic-action flushing-cisterns.

Most water companies insist upon some form of

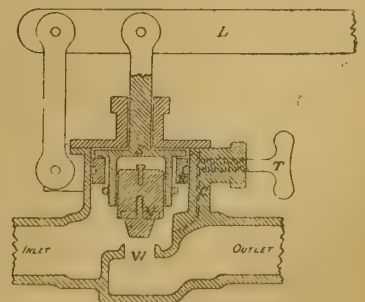

Fig. 25.

water-waste preventing cistern being used for flushing closets, &c.; but where this is not compulsory, a type of fitting known as a "waste-preventing closet-valve" is sometimes substituted. On lifting a handle, the valve (which is usually fixed on the flushing-pipe immediately under the closet-seat) is opened, and a certain quantity of

water allowed to pass for flushing purposes. So soon as the prescribed quantity of water has passed, the valve closes, even though the handle be kept raised.

Fig. 25 shows the general arrangement of Tylor's patent waste-preventing closet-valve. The plunger or valve V is so arranged as to be perfectly free to move up and down within the carrier or socket S, which is attached to the lever L by means of a short connecting-rod or spindle. The descent of the socket is capable of being controlled by the loose ring R. A small passage or channel C allows the water to flow from the under to the upper side of the ring, which can be regulated by means of the tap T.

The action of the valve is as follows:—On lifting the closet-handle, the socket S is correspondingly raised, whilst at the same time the valve V and the ring R also ascend by suction. If the handle is then released, the carrier or socket gradually commences to fall, the velocity of its descent being controlled by the quantity of water which is permitted to pass to the upper side of the ring R, through the channel C. Should the closet-handle be kept raised, then neither the

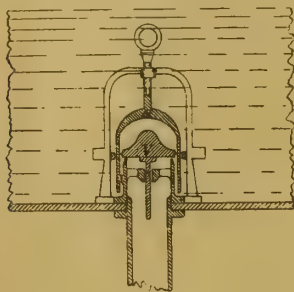

FIG. 26.

socket S nor the ring R can descend; but the valve V—being perfectly free—will slowly fall by means of its own weight and the pressure of water until it rests upon its seating W, thus cutting off the water-supply to the closet.

Another type of "water-waste preventing valve" is also sometimes used. It is intended to be fixed under water, and within the cistern supplying the closet. Fig. 26 is a sketch of a well-known patented form of "waste-preventing cistern-valve." The principle of construction is essentially the same as the waste-preventing closet-valve just described. When the closet-handle is raised, the carrier or socket S is lifted, and at the same time the loose plunger or valve V is carried upwards by suction, thus allowing the water in the cistern to escape down the flushing-pipe. On releasing the handle the socket descends, and the valve V returns to its seating. If the handle is kept raised, the carrier or socket is also held up, but the loose valve V gradually descends by its own weight and the pressure of water until it falls upon its seating. By this means the supply of water to the closet is shut off directly a certain quantity of water has passed.

#### USEFUL ITEMS FOR BUILDERS, PLASTERERS, PAINTERS, PAPER-HANGERS, &c.

(Concluded from page 340.)

66. **TO** fix glass letters on shop-fronts: Make a thick solution of marine glue in wood naphtha, and apply this to the glass surface after having cleaned same.

67. Cement for fastening glass and metals together: Glass can be made to adhere to any other substances by means of a mixture of gum arabic and calomel (mercurous chloride). Digest best quality gum arabic in water until a mucilage as thick as treacle is made, and stir into it sufficient calomel to make a sticky mass, and mix up in a plate with a bone spatula. Make only just as much as is required for use. Allow the compound a day or two before use, but it may be used directly it is mixed. This cement hardens in a few hours.

68. The usual cement for affixing metal letters to glass shopfronts is prepared by melting together up to the heat of a water-bowl, 15 parts (fluid measure) of copal varnish, 5 parts (ditto) drying oil, 3 parts (by weight) of Venice turpentine, 2 parts (fluid measure) of oil of turpentine, and five parts of liquefied marine glue,

and to the melted compound add 10 parts (by weight) by slaked lime.

69. A very secure and quick-drying cement for identical purpose is prepared by boiling 3 parts of boiled linseed oil with 1 part of white-lead and 2 parts of litharge (both in powder), and then adding 1 part of copal resin powdered, and continue the heating until the resin is melted.

70. A waterproof cement for the same purpose is prepared by melting 4 parts of glue in the least possible quantity of water, and then adding 1 part of Venice turpentine.

71. Glue for joining wood to stone or glass: Mix dry wood ashes (beech ashes preferable) with ordinary glue at boiling point until the mixture is of the consistency of thick syrup. Use while hot.

72. A cement for uniting transparent objects (such as glass letters in shop windows): Make a solution of acid chromate of lime in water, and use 1 part of the solution to 5 parts of softened gelatine. The chromated gelatine will harden to an insoluble cement when exposed to light.

73. Glue for fastening leather, leatherette, &c., to walls: Mix 20 fluid ounces of rye whisky with the same quantity of water, and then stir in  $4\frac{1}{2}$  ounces of powdered starch to make a thick paste; separately dissolve  $1\frac{1}{2}$  ounce of good glue in an equal weight of water, and melt this by heat; then stir in  $1\frac{1}{4}$  ounces of Venice turpentine in the glue solution, mix thoroughly, and then mix the glue and starch and compound together and well incorporate.

74. A cement for uniting guttapercha connections of electrical apparatus is made by melting together by heat 1 part of tar, 1 part of rosin, and 3 parts of guttapercha.

75. Another cement for the same use is made by dissolving 2 parts of common pitch with 1 part of guttapercha by heat. Make the mixture in a saucepan, and when fluid pour out into cold water. When cold it is a black elastic solid, but readily softened by heat, and at  $100^{\circ}$  Fahr. it is a thin fluid. It may be used in either fluid or solid state—in the latter case, just as putty is used.

76. Cement for affixing leather to various materials: Dissolve 20 parts of guttapercha and 20 parts of black pitch in 3 parts of oil of turpentine.

77. A cement for the same purpose is made by dissolving guttapercha in bisulphide of carbon until it is of the consistency of treacle.

78. A ditto cement is made by melting together in two parts of linseed oil 16 parts of guttapercha, 4 parts of indiarubber, 2 parts of colophony, and 1 part of shellac.

79. Gasket for putting between manholes and other removable parts of steam boilers, hot-water apparatus, &c.: is made by mixing the following ingredients to a stiff putty:—10 parts of graphite (or plumbago), 3 parts of whiting, 3 parts of litharge in sufficient linseed-oil varnish.

80. Cement for joining indiarubber connections of electrical apparatus: Dissolve in sufficient bisulphide of carbon 10 parts of indiarubber chopped up small,  $1\frac{1}{2}$  part of rosin, and 1 part of shellac.

81. To glue leather to iron: Melt equal parts of asphaltum and guttapercha. Apply hot, and put under pressure until dry.

82. Cement for hot-water and steam-pipes: Compound: 10 parts of white-lead ground in oil, 3 parts of black oxide of manganese, and 1 part of litharge.

83. Another cement for a similar use is prepared by mixing 6 parts of dried clay and 1 part of iron filings in boiled linseed oil, so as to make a paste.

84. A cement for repairing cast-iron tanks is prepared by melting at a low heat (so as to prevent the brimstone catching fire) 5 parts of brimstone, 2 parts of blacklead, and 2 parts of sifted cast-iron filings. Before applying this cement, warm the metal by laying a red-hot iron over it. The metal must be perfectly dry, so as not to generate steam, and then stop up the damaged part with the cement applied in a soft state by gently heating it in an iron ladle.

85. Cement for affixing leather, paper, &c., to iron girders, pillars, &c.: Make some carpenter's glue in the usual way, and then stir in pure tannin until the glue becomes ropy, and spread this on the cloth and metal. If the iron has a polished surface, first coat the smooth surface with a coating of white-lead; and when that has dried hard, give a coating of Russia glue dissolved in water, to which has been added a little vinegar.

86. To fasten copper in sandstone, rub up

4 parts of linseed oil and varnish, 7 parts of white-lead, 6 parts of litharge, 6 parts of bole, and 4 parts of broken glass.

87. To repair cracks in ovens, mix into a paste with water when about to use it a compound composed of 2 parts of litharge, 1 part of fine sand, and 1 part slaked lime.

88. To attach fibrous material to metal, soak good glue in water for 12 hours, and then dissolve the softened glue in hot vinegar, and add one-third of its volume of white-pine pitch, also hot.

89. A cement for gasfitters' use: melt 9 parts of rosin and 2 parts of beeswax, and then stir in 6 parts of red ochre or other red oxide of iron.

90. Cement for cracks in hot-water pipes: Mix 10z. of powdered salammoniac with 100oz. of iron borings, and ram them well into the crack or joint; or else mix 12lb. of iron filings, 2oz. of salammoniac, and 1oz. of sulphur, worked up in water.

91. To cement iron to stone: Mix together one part of iron filings and seven parts of plaster of Paris (by weight both ingredients) and make into a paste with water; use at once.

92. To repair cracks in iron grates, mix to a stiff paste five parts of wood ashes, five parts of clay, and two parts of burnt (quick) lime.

93. To cement iron railings, girders, &c.: Mix together six parts of sulphur, six parts of white-lead, and one part of borax; then, when wanted for use, moisten it with strong sulphuric acid, and place a thin layer of it between the pieces of iron which are to be joined. In five or six days the cemented pieces will be firmly attached.

94. To protect iron structures from rusting mix 1 part of quicklime with 5 parts of water, stir it up to allow the lime to settle; then pour off the clear water, and mix the lime with sufficient olive-oil to make a thick cream, and paint this over the iron surfaces to be protected.

95. To fix metal letters on glass mix 3 parts of copal varnish, 1 part of linseed-oil varnish, 1 part of oil of turpentine, and 1 part of liquefied glue; or else this compound, which is suitable for fastening metal letters on any material: melt together 15 parts of copal varnish, 5 parts of drying oil, 2 parts of oil of turpentine, 5 parts liquefied glue, made with the least possible quantity of water; when the mixture is well stirred put in 10 parts of fresh slaked lime that is perfectly dry.

96. To repair broken stone, prepare a powder and a liquid as follows: mix and grind 2 parts (by weight) of oxide of zinc, 2 parts of crushed limestone of a hard nature, and 1 part of crushed grit, and add ochre in suitable proportions to colour the mass. To prepare the fluid, make a saturated solution of zinc in commercial hydrochloric acid, and add thereto hydrochlorate of ammonia equal in weight to one-sixth of the dissolved zinc, and dilute the mixture with two-thirds of its bulk of water. To use the liquid, mix 1 part of the powder compound with  $2\frac{1}{2}$  parts of this liquid.

97. To cement steam pipes, make into a paste 8 parts of native or else precipitated sulphate of barium, 6 parts of graphite (or plumbago), 3 parts of slaked lime, and 1 part of boiled linseed-oil.

98. Putty for steam-pipes: Mix 2 parts of a good metallic paint, 1 part of litharge, and 3 parts of dry iron borings (or filings) with sufficient linseed-oil to make a stiff putty.

99. Putty for repairing broken stones (the heat will harden this cement). Reduce the following ingredients to powder. Mix all together in a mortar and make into a thick putty with water just before use: 10 parts of clay, 4 parts of fine iron filings, 2 parts of peroxide of manganese, 1 part of common salt (sodic chloride), and 1 part of borax.

100. A cement for a similar purpose that will resist a very high temperature is prepared by making into a paste with solution of silicate of potash and borax 1 part of sulphate of barium and 2 parts of clay.

101. Cement for water-pipes: Mix 5 parts of zinc white, 4 parts of pyrolusite, and 1 part of sodium silicate.

102. A waterproof glue is prepared by adding 4 parts of common rosin to 4 parts of hot glue, and stirring in 1 part of red ochre.

103. A glue for universal use is made by stirring dry powdered chalk with common glue.

104. To keep glue elastic, and free from cracking, add a little chloride of calcium to the glue made in the usual way; a little glycerine also has the same effect, but not too much must

be used, or the glue will attract moisture, and be non-adherent.

105. A putty for mahogany is prepared by melting 4 parts of beeswax and whiting in 1 part of Indian red, and 1 part of yellow ochre or shellac may be melted and coloured with these pigments, and used for the same purpose.

106. Common putty is made by mixing thoroughly dry whiting with raw linseed oil. A little dry white-lead may be added as well as ochre to colour the putty.

107. A good floor putty is prepared by melting 1 part of glue in 8 parts of water, and then stir in 1 part of litharge, 2 parts of plaster of Paris, 4 parts of curds (from curdled milk), and 2 parts of sawdust. If the floors are to be varnished, dissolve 1 part of glue in 6 parts of water, and then work in 2 parts of plaster of Paris, and 1 to 2 parts of litharge.

108. An imperishable putty is prepared by boiling 4 parts (by weight) of brown amber in 7 parts (by measure) of linseed-oil for two hours. Then melt in two parts of wax, and afterwards stir in  $5\frac{1}{2}$  parts of powdered chalk and 11 parts of white-lead, and thoroughly incorporate the whole.

109. Putties for cracks and joints: Mix 2 parts of glue in 1 part of water, and then stir in 7 parts of cement and 3 to 4 of sawdust; or else mix 1 part of powdered slaked lime with 2 to 5 parts of rye flour, and make into a putty with 1 part of linseed-oil varnish, and thin the mass with sufficient water to make it thin enough for use.

110. Russian glue is made by soaking 100 parts of good glue in 120 to 140 parts of water, and melting by heat, then adding 5 to 6 parts of nitric acid, and afterwards 6 parts of sulphate of lead in powder.

111. Glue for green or damp wood is prepared by soaking good glue in water until soft; then dissolve it in the smallest possible quantity of proof spirit by the aid of a gentle heat. In every pound of this mixture dissolve 3oz. of gum ammoniac, and while liquid add  $\frac{1}{2}$  fl. oz. of rectified spirit of wine; stir well, and for use keep it liquid by standing the vessel in hot water.

112. Glue for veneers: Dissolve a good quantity glue in water, and to every pint of this solution add 5oz. best vinegar and  $\frac{1}{2}$  oz. of isinglass.

113. A marine glue is prepared by dissolving 1oz. of unvulcanised indiarubber in 20 fl. oz. of coal naphtha; then rub it smooth on a slab with a spatula or palette knife, and add at least enough to melt two parts shellac by weight to one part of this solution. Heat this compound to 250° Fahr. when using.

114. Glue for damp walls that are to be papered: Dissolve one part of asphaltum by heat, and add 1 part of rosin, and then stir in 2 parts of powdered whiting. Separately dissolve 2 parts of caoutchouc in 4 parts of oil of turpentine, to which 2 parts of bisulphide of carbon has been mixed. Then mix these two compounds (the rubber and glue solutions) by heating at a gentle warmth. Cleanse the wall by scraping, and then brush on the above compound on the damp places, and before the glue is dry put on plain paper, over which, when dry, put on the wall-paper.

115. To make common glue waterproof add a little tannic acid dissolved in water to the hot glue.

116. Paperhanger's paste: Mix powdered alum into the flour before mixing in the parts to the proportion of 13 of alum to every 666 of the flour. Instead of alum, powdered rosin may be mixed in the paste after having made it in the usual way. The rosin should be strewn in the paste while it is boiling hot, so as to cause the rosin to dissolve.

117. To fasten tapestry and textile hangings on walls, &c.: Make a paste of rye-flour, and then stir in good glue in the proportion of 1 part glue to 4 parts of flour originally taken. The glue should be melted in the usual way before being mixed with the paste. A few drops of carbolic acid or essential oil of cloves will prevent this compound decomposing or putrefying.

118. Modelling paste for architects and draughtsmen: Boil white paper to a pulp by boiling it in water for four to five hours. Then pour off the water, and pound the paper in a mortar; pour it through a sieve, and mix with some gum water or isinglass glue.

119. Red-lead cement is made by mixing red-lead with linseed oil to a paste, and is used by plumbers, gasfitters, and for metal pipes.

120. Plaster for insulating steam-pipes: Puddle some clay in water to a thin fluid mass, and then mix in felt, cork waste, chopped straw, or asbestos,

so as to make a stiff compound, and plaster this on the pipes while moist. To prevent this compound cracking and falling off, mix infusorial cement with silicate of soda or of potash, so as to form a fluid of the consistency of paint, and then brush this over the insulating layer of clay, and when dry give a second or third application, and finally a coating of drying oil may be given to prevent efflorescence of the silicate.

H. C. S.

### THE SURVEYORS' INSTITUTION.

AT the ordinary general meeting of the above Institution on Monday evening last an interesting paper was read by Mr. Harley M. Grellier on "Tithe Rent-Charge Recovery," dealing especially with the changes which the Act of 1891 had made in the procedure under the Tithe Commutation Act of 1836. Under the older Act, tithes were, with certain exceptions, discharged, and for payment in kind or in the form of a voluntary composition, was substituted a rent-charge, fluctuating annually with the average prices of wheat, barley, and oats, calculated on the average of the seven previous years, in order to avoid too sudden fluctuations in good or bad seasons. This sum was payable in half-yearly portions, and was recoverable by distress and entry, it being expressly provided that no one should be personally liable for the payment, and that not more than two years' arrears should at any time be recoverable by distress. Although tithe rent-charge was regarded as an owner's liability, the tenant was given power to deduct from the rent the sum paid by him, as part of the consideration on which he held the land, and it became the custom for the tenant so to pay it direct. There were good reasons for this, for where the land was let tithe free, and the landlord neglected to pay it himself, the goods of the tenant were liable to seizure as the only tangible security of the tithe owner. The agitation in Wales, due to various political and other causes, hastened the passing of the Tithe Act of 1891, which introduced an entirely new method of procedure, and, starting with the fact that tithe rent-charge is a liability attached to the land, it provided that it should be payable by the landowner in every case, notwithstanding any contract or agreement to the contrary; and that where any sum due on account of rent charge is in arrear for not less than three months, the person entitled to it might apply to the County Court for an order for its recovery, either by distraint on the lands when they are in the occupancy of the owner, or the appointment of a receiver of the rents and profits in every other case, due notice and the opportunity of appearing and being heard being given. In cases of contracts entered in before 1891 for the tenant to pay the charge, he is bound to pay it, but to the landowner, and not direct to the tithe owner. In the case of lands of one owner situate in different parishes, the Court has power to apportion the charge on them according to their ratable value. The author then dealt exhaustively with the method of procedure under the Act for the recovery of tithe rent-charge which was three months overdue, the service of notices, the fees to be paid in the notice of opposing the application, and the hearing of the case, which, if the application be unopposed, may be decided without a hearing. After a receiver has been appointed by the Court—in the case of lands not in the occupancy of the owner—notice is given to the occupiers to give all particulars required as to their tenancies, and if they refuse to do so they may be compelled by summons to appear as witnesses, bringing the necessary books, papers, and documents in their possession. So much, said Mr. Grellier, depended upon the correct appreciation of the term "owner" as used in the Tithe Act, that it was well to consider its meaning very carefully. "Owners" were not only persons having a fee-simple interest in the land, but included every person in receipt or possession of rents or profits of lands or tithes without regard to their real amount of interest. Tenants for life, or leasees for lives or for a term originally exceeding fourteen years, holding at a rent less than two-thirds of the clear annual value of the premises, are owners, although the persons to whom they pay rent are joint-owners with them. The building lessee holding for a long term is an "owner," and in practice he alone may in most cases be treated as such by an applicant, for

in the case of a joint-ownership, service on the owner in possession of the rack-rents is good service on the other owners, and proceedings might be taken against the "owner of the lands" in cases of difficulty, without any name being mentioned on the notice of application. The case of "Peed v. King" decided that the only rents the receiver can take were the rack-rents payable by the actual occupiers of the premises. The last Act also introduced the principle of the remission of a certain portion of the tithe under certain circumstances, on the ground that the tithe rent-charge should never be permitted to exceed the profits on the land, the assessment of the land under schedule B of the Income-tax being taken as the gross annual profit, and the net profit being arrived at by deducting one-third to cover repairs, maintenance, and management.

Mr. Grellier proceeded to give many details of costs, tithe redemption, the calculation of the corn averages, cases which had been decided bearing upon the subject, and after a short discussion, in which Mr. J. H. Sabin, Mr. H. C. Newmarch, Mr. C. Geppis, Mr. H. Grindall, and Mr. Jonas took part, the meeting adjourned.

The next meetings of the Institution will be at Manchester on the 20th and 21st prox.

### WROUGHT-IRON AND STEEL IN CONSTRUCTIONAL WORK.—XXXV.

PROVISION for expansion and contraction due to changes in temperature has to be made in most structures of considerable linear dimensions. The character of this provision and its extent depends on various conditions, being simple and of slight amount in some cases, and the reverse in others. All work in iron or steel must, however small its dimensions, vary in size with alterations in temperature. But in many instances the effect can be neglected. The natural elasticity of these materials will often suffice to fully compensate for such alterations, due to their yielding, by virtue of that elasticity, into varying curves or cambers, and returning again to normal conditions. This is the case in all arched structures, the effect of expansion being to increase the height of the arch or camber, by a difference corresponding with the increased length of the metal measured round the arc. So long as these extensions are well within the limit of natural elasticity of the material no harm can result. The Forth Bridge cantilevers, though they stand so high over the piers, contain no provision for vertical expansion, because it is taken up by the elasticity of the steel. It may happen in some instances that the increase in the height of an arch might interfere with the level of a roadway, or railway, though the expansions would in themselves be of no moment. For this reason partly, pivoted arches are regarded with favour by many engineers, and several bridges have been built on this principle, the arches being pivoted both at the springings and at the crown. Some large roofs have also been constructed on the same principle. When absolutely linear structures confined at both ends are concerned, then it is necessary to make some provision for expansion, the nature and amount of which will vary. In many cases it is sufficient to put one set of bolts through slot-holes, the slots moving along past the bolts, and the structure sliding on planed plates. The columns of the Kuzin Viaduct in the Alleghanies are free to move in this way. In large roofs, allowance has been made for the expansion of purlins in a similar way, one end of each purlin being attached to brackets on the main spans by means of slotted bolt-holes. In bridges, in some cases broad planed sliding surfaces only are used; but generally, when the movement amounts to an inch or two, rockers are employed; when to several inches, rollers; while when of greater amount, very special arrangements have to be devised, since all cases are not so simple as that of a girder sliding on a plain base.

All lattice bridges of any considerable length are fitted with expansion bearings of one of these types. One end only is fixed, and the other end is generally supported on rollers or rockers which sustain the weight of the free end, and on which it moves during expansion and contraction. There is not much essential difference in the general type on which these bearings are constructed, but the number and details vary widely. Figs. 244, 245, illustrate the fixed, and Figs. 246,

247, the expansion bearings for a bridge over the Nerbudda, belonging to the Indian State Railways.

At the fixed end, Figs. 244, 245, a plate, A, riveted to the bottom boom B receives a broad,

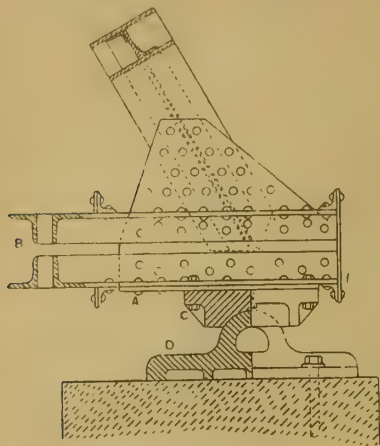

FIG. 244.

stout casting, C, which is recessed out to take a casting, D, bolted down to the pier. There is nothing beside the weight of the superstructure necessary to retain these in place. At the expansion end, Figs. 246, 247, the upper casting C

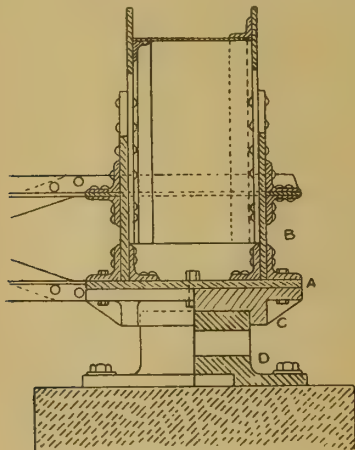

FIG. 245.

is similar, but the lower one D rests upon the live rollers E, which in turn rest upon the casting F, bolted to the pier. The rollers are merely placed between the top and bottom castings, being

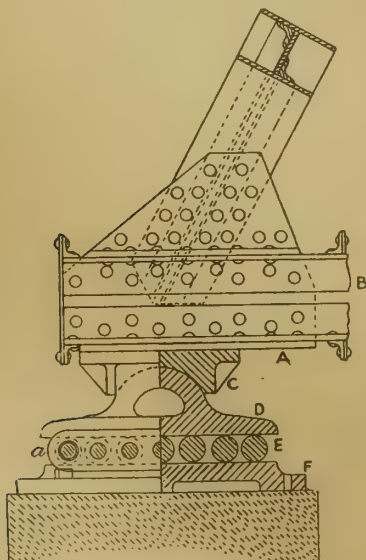

FIG. 246.

retained equidistantly by means of end cradles, aa. The semicircular fitting of the castings C and D prevents the varying deflections of the bridge from putting strain on the bearings.

As a rule, mild steel is used for rollers and rockers, cast steel for their bearing castings, and cast iron for the base, which is fastened to the masonry with bolts. To insure a good joint between the latter, sheet lead is sometimes interposed, 6lb. lead being a suitable thickness.

Much care has to be exercised in the fitting. The rollers are always turned, and sometimes ground in addition. The surfaces on which they move are planed, and the top bearing is planed to fit the bottom boom.

Figs. 248-251 illustrate the bearings of

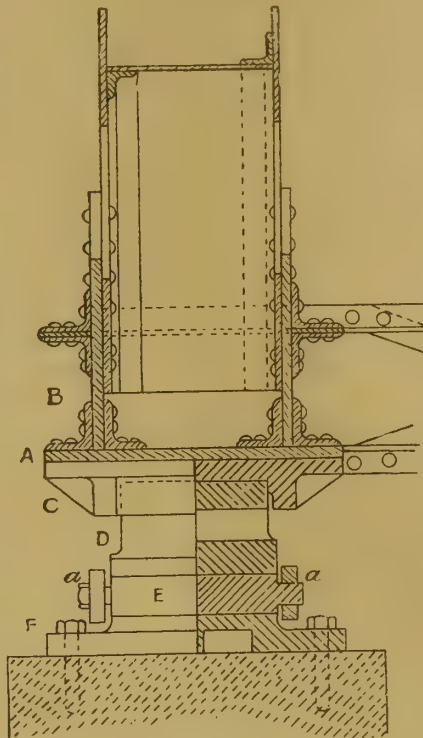

FIG. 247.

viaducts on the Manchester Ship Canal, the viaducts being built of lattice girders, each 156ft. long. Fig. 248 gives one view of the fixed bearings, and Figs. 249-251 views of the movable ones. The span being short, rockers are used instead of rollers for the latter. In Fig. 248 the top and bottom saddles A and B are of cast steel, and the pin C is of mild steel. The top saddle is attached with turned bolts to the bottom boom. In the rocker bearings, Figs. 249-251, cast, and mild steel are used similarly. The rockers are turned on their bearing faces. They are inclosed in a built-up frame, and retained in place by set-screws, the rollers and frame being seen detached in Fig. 251. There are side-guards on top and bottom saddles;—Figs. 249 and 250, to act as

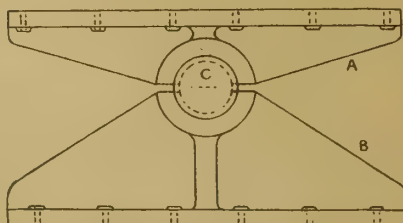

FIG. 248.

checks on the rollers sideways. The steel castings are strongly ribbed, Fig. 249; and those in Fig. 248 are ribbed similarly, in order to afford ample strength to resist crushing stresses. Figs. 252 and 253 show roller bearings which differ slightly from the preceding. The frame is united with bolts passing through distance-pieces, and the rollers are turned down in the centre. They are but light, being 3in. diam., for a single-line light railway bridge.

Probably no structure has ever been erected in which the effects of temperature had to be taken account of under such difficult conditions as the

Forth Bridge. It was necessary to await a definite rise in temperature, in order to make some of the permanent connections. An allowance of no less than two feet was considered

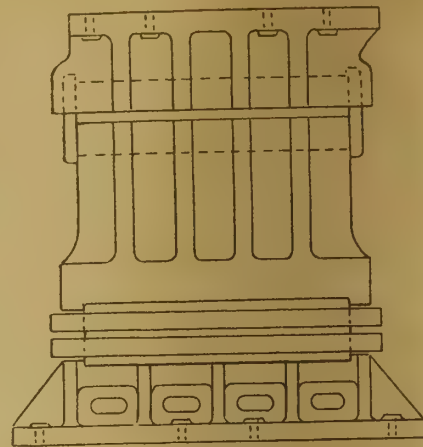

FIG. 249.

requisite to make between the cantilevers and central girders, and the nature of the connection between these rendered expansion rollers impracticable. These, in fact, were only employed in one portion of the bridge—namely, in the cantilever end piers. At the ends of these fixed cantilevers a movement of one foot is provided for. Elsewhere, the methods adopted were of an original character. In this bridge, too, the movements are of so complicated a nature that it

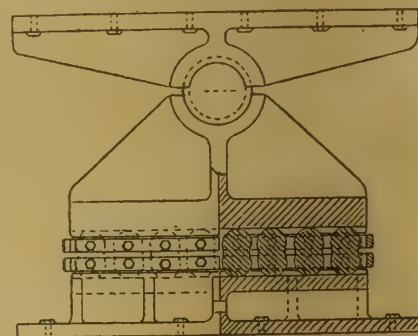

FIG. 250.

was necessary to make provision for them in more than one direction. Thus, the effect of the sun shining on one side of the bridge, and of a cold wind blowing on the other, would be to warp or curve it, and the same effect would follow from a strong wind blowing on one side of the bridge. Since the connection between the cantilever girders and the central girder cannot be rigid, it was necessary to contrive a pivoted joint for horizontal swing,

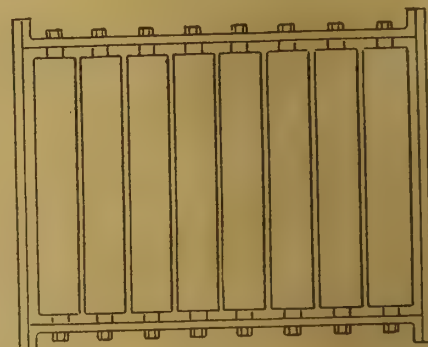

FIG. 251.

with the joint for longitudinal movement. The distance between Inchgarvie and Queensferry is 1,970ft., and between Inchgarvie and Fife 1,710ft. The maximum provision made between each of these is 24in., and is located at each end of the Inchgarvie cantilever. The distance was settled by experiment only, after many careful measurements taken at different times, and at

various temperatures; and this determined the length of the middle girders, so that there should be sufficient play between them and the cantilevers under the greatest heat of summer, with

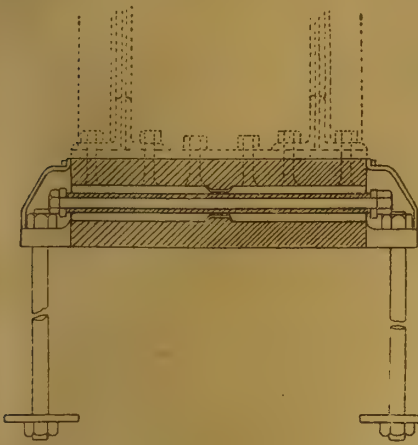

Fig. 252.

full sunshine. At the mean temperature, which is 51° Fahr., the bottom booms of the central girders stand about 1ft. away from the ends of the cantilevers.

The expansion connection is effected by means of rocking-posts (Fig. 254) and slide blocks (Fig.

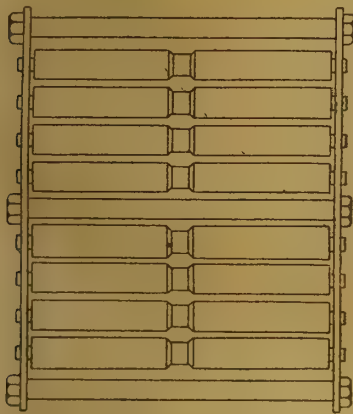

Fig. 253.

255), and expansion joints in the rails. The rocking-post (Fig. 254) forms a connection by ball and-socket joints, with the top boom B of the central girder, and bottom boom C of the cantilever, the top boom of the former projecting



Fig. 254.

into the cantilever. At the normal temperature these posts are vertical, but move out of the perpendicular with thermometric changes. The ball-and-socket joints D, E, of 12in. radius, were selected by reason of their large bearing surface,

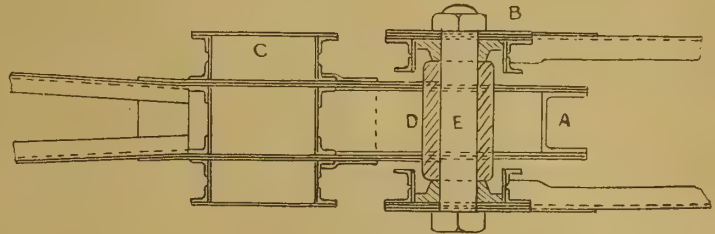
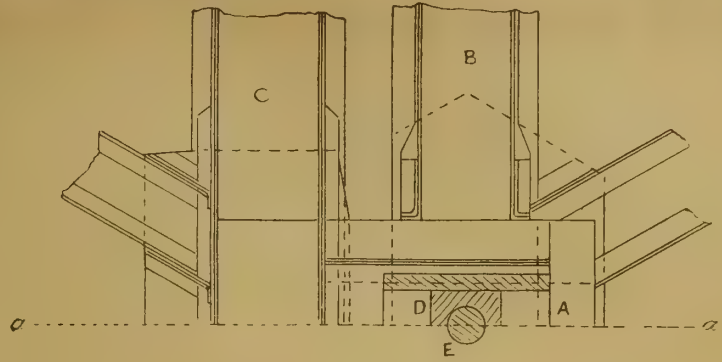

Fig. 255.

far in excess of that of suspending links. The posts A are built of steel plates and angles, and the balls and sockets are steel castings. The weight is thus transmitted from the top booms and rocking-posts to the bottom booms of the cantilevers, and side horizontal movement can

ment is provided for, as previously mentioned by rollers, and also side and vertical movements, Fig. 257. Here steel castings, A, are bolted to the bottom ends of the cantilever. These rest on the head of the roller bearing castings B, which are of the ordinary type, the

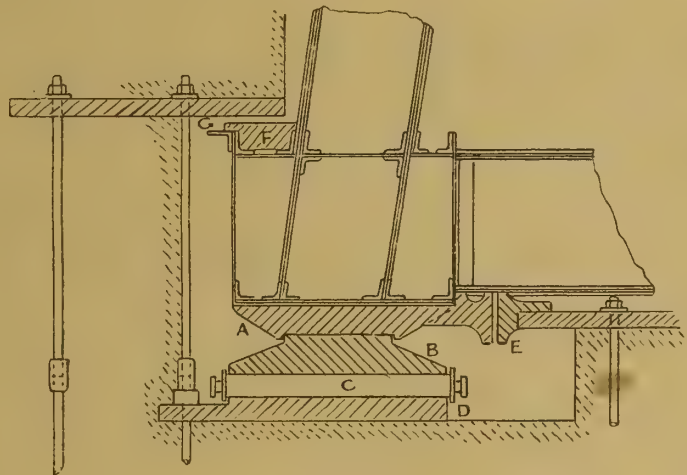

Fig. 257.

also take place. To maintain the booms in alignment, while yet allowing freedom to move lengthwise, and to pivot, a tongue or bracket A is carried (Fig. 255) from the cantilever C to the central girder B in the longitudinal centre of the bridge. The upper part of Fig. 255 illustrates this connection in half-plan view, a-a being the longitudinal centre, and the lower half is a section taken perpendicularly to the former view. The tongue A passes from the last cross-girder of the cantilever into that of the girder, a similar construction occurring both

rollers C moving in a frame between top and bottom plates B and D. To limit movement sideways, a projection with a flat face on the side of the cantilever castings, A, will come into contact with a projection on a plate, E, bolted to the masonry. To prevent possible rising of the cantilever due to gusts of wind, which might overstrain the metal, steel castings, F, are attached to them, to come into contact with overhanging castings, G, built into the masonry.

These examples cover most of the ground; but with differences in design different problems have to be solved. The Tower Bridge has a complicated system of roller bearings to carry the chains over the main columns, the Niagara Suspension Bridge has an automatic arrangement of lever and wedge to compensate for 8½in. of expansion. With increase in dimensions and complexity of form, the problems of compensating for the expansion of iron and steel structures demand more original solutions. Once on the Forth Bridge, a sudden fall in temperature taking place during the making of a permanent connection, about thirty rivets were shorn off, with a report like a 38-ton gun. Sometimes artificial heat had to be applied to girders to permit of riveting up parts. J. H.



Fig. 256.

in top and bottom. It has a slotted hole with faced sides, in which slides a block, D, 15in. square, secured by a 9in. bolt, E, to the first cross-girder of the centre girder. A long expansion-rail joint over each junction of girder with cantilever is also made, being devised in such a way that the gauge is always preserved constant. Fig. 256 shows the pivot of the fixed end uniting girder and cantilever.

In the cantilever end piers longitudinal move-

The proposed Thames-side line from Marlow to Henley-on-Thames, promoted by the Great Western Railway Company, will not be proceeded with.

### COPYING PROCESSES FOR REPRODUCING AND DUPLICATING DRAWINGS, PLANS, &c.

THE old familiar process of copying a plan by tracing it on tracing-paper is hardly consistent with the present go-ahead times. By means of chemical and photographic processes a much more rapid means of reproducing a plan is ready to hand. If the plan be one that is washed-in with various water-colours, a photographic method of reproduction is the only one to use. If the plan be one that is drawn in ink which contains a salt of iron and copper (such as most writing-inks do), then the blue or brown process of reproduction may be followed. Both these processes depend for the result on the chemical reaction that takes place between the iron or copper salt in the ink and the ferrocyanide of potassium with which the paper has been treated which is to take the copy.

Other methods of copying, such as the cyclostyle, hectograph, &c., are suitable for many cases that crop up in an architect's office. The following description will put the reader in possession of all necessary details for carrying out any of the copying processes in vogue.

#### PHOTO-CHEMICAL PROCESSES.

The following processes depend for their success on certain chemical reactions which occur in the treated paper when subjected to the influence of light:—

No. 1.—Prepare two compounds (*a* and *b*) as follows:—Compound (*a*): 15 parts of curd soap, 15 parts of alum, 20 parts of glue, 5 parts of albumen (white of egg), 5 parts of spirits of wine 60° strength, 250 parts of water, 1 part of glacial acetic acid. Preparation: Cut up the curd soap (this is a white hard soap made from tallow and soda salts), and dissolve it by gently heating in about twice its weight of water, separately soak the glue in its own weight of water until it is soft (about 12 hours), and then gently heat it and mix it with the soap solution; stir well until the mixture froths and is homogeneous. Mix the acetic acid with the spirit and the albumen in the remainder of the water, dissolve the alum; finally mix all together. Compound (*b*): 25 parts of burnt umber ground up in spirits of wine, 10 parts of lampblack, 5 parts of glue, 5 parts of bichromate of potash, 250 parts of water. To prepare the paper that is to take copies of drawings, first dip it in compound (*a*), and then, after drying, in compound (*b*), when it will be sensitive to light, and should be preserved in the dark. This paper will be the negative paper. For preparing the positive paper, treat it in the above manner without the aid of burnt umber, and only lampblack or any other suitable coloured pigment which will not be reacted on by the chemicals used. To take a copy, put the drawing of which a copy is to be obtained, in a photographic printing-frame, and lay a sheet of the negative paper over it, and expose the frame to the sun's rays for about two minutes (in cloudy weather a longer exposure is necessary). After exposing the negative paper, put in water to develop it, when a facsimile of the drawing will appear on it in white lines on a black ground, or as a negative or reverse picture. Dry the negative paper thus printed and place it in the glass of a printing-frame, and then lay a sheet of the positive paper on it close up to the frame, and expose to light as before, when the positive paper will be printed on, and the drawing will be developed by placing the positive sheet of paper in water, whence the black colouring matter is dissolved off, and the drawing appears.

No. 2.—To reproduce drawings made in black and white:—The reproductions may be made on paper or on linen by twice coating material with the following compound:—5fl.oz. of water, 135gr. of chloride of iron, 70gr. of citric acid, 217gr. of gum arabic. Place the material coated with the compound under the drawing to be copied, with the prepared surface to the drawing, and expose to strong sunlight for five or fifteen minutes, according to the thickness of the paper on which the drawing is made; then dip the copy in a solution of yellow prussiate of potash or of nitrate of silver to be developed, and then wash it in a solution bath of water which has been slightly acidified with sulphuric or hydrochloric acid.

No. 3.—To produce copies in black lines on white ground. Sensitising bath prepare as follows:—In 47oz. of distilled water dissolve 4oz. of tartaric acid, 5oz. of sulphate iron purified crystals, 10oz. of perchloride of iron (45° Be.),

3oz. of common salt (sodic chloride), 25oz. of gum. For the developing bath use a solution of red or yellow prussiate of potash (i.e., ferricyanide or ferrocyanide of potassium). It does not matter whether this solution be alkaline, acid, or neutral. After removal from this bath, wash the paper in water to free it from excess of prussiate, and then dip in a solution of acetic, hydrochloric, or sulphuric acid. To take copies of the drawings, sensitise sheets of paper by dipping them in the sensitising bath and then drying them in the dark. Then put this sensitised paper in the photographic printing frame, and lay over it the drawing which it is desired to copy, and expose the frame to sun or strong light. Then remove the sensitised paper, and dip it in the prussiate solution to develop the printing, and afterwards pass it through water, and finally dip it in the acidified water, and dry. The parts of the sensitised paper which did not receive the light will take a dark-green colour; but the other parts do not change. After washing, however, the lines which have been printed on the sensitised paper will be of a deep indigo or black colour.

No. 4.—To change blue printing on a white ground to black proceed as follows: Make a solution of potash by dissolving 1oz. of common potash in 25oz. of water, and dip the blue-printed proof in this solution, when the blue figures will assume a rusty-brown colour by conversion into iron oxide; then dip this proof in a solution composed of 1oz. of tannic acid and 20oz. of water. The brownish oxide of iron will be changed to a black colour by the tannic acid, and this is fixed by washing the print in pure water.

No. 5.—Sensitise paper as follows: Make a solution of bichromate of potash, and dissolve in it some gum or white of egg; and then mix in the solution some lampblack or other inert pigment, such as water, and brush this over the sheets of well-sized paper as evenly as possible, doing this in a dark room or by lamplight, and dry the paper in the dark. On a sheet of thin sensitised paper lay the drawing (which, if not done on transparent paper or tracing-paper should be oiled and dried so as to render it translucent), and expose the drawing to the light in a photographic printing-frame. Remove the drawing from the sensitised paper, either in a dark room or else by lamplight, and wash the sensitised paper with water, when a negative of the drawing remains, as the portions of the coating which have been acted on by light are insoluble in the water. By preparing a negative like this a large number of positives may be taken.

No. 6.—To take copies of drawings, plans, &c., that have been done in printing-ink: Wet a piece of stout paper in water and lay it on the printed matter it is desired to copy, and then rub the back of this paper with an agate burnisher or ivory handle of a knife, when a negative of whatever is done in the printer's ink will be obtained. If the ink does not readily yield a copy, moisten it with spirits of wine, or spirits of wine in which a little essential oil of lavender has been mixed. Lay a piece of blotting-paper beneath the printed one.

No. 7.—Sensitise the paper to be used for copying in the following solution:—1½ pint of distilled water, 1oz. of sulphate of iron, 1oz. of sesquichloride of iron, 1oz. of gelatine, 1oz. of tartaric acid. After sensitising the paper, keep it in a dark receptacle, not rolled. For use, lay the drawing which is to be copied—the paper on which same is drawn should be transparent—on the sheet of sensitised paper, and then expose same to light, when the parts of the sensitised paper which are influenced by the light will lose their greenish-yellow colour. For a developing solution, mix 1fl.oz. of alcohol, 9½oz. of gallic acid, 50fl.oz. of water, and dip the exposed drawing in the fluid, when the greenish-yellow lines turn black at once. Rinse in clean water, and dry.

#### CYANOTYPE COPYING PROCESSES.

Blue-print process: Sensitise the paper with the following solution:—10fl.oz. of distilled water, 1oz. of soluble citrate of iron (or else double citrate of iron and ammonia), 1oz. of red prussiate of potash. Mix these ingredients when required for use, and brush it over the surface of the paper to be sensitised as uniformly as possible. The sensitised paper should be kept in the dark out of the reach of light until it is required for use, the process of which is as follows. Cover a drawing-board with two or three thicknesses of blanket, and upon this place the sensitised paper, with the sensitised side uppermost; then lay the

drawing to be copied, which should be on tracing or other transparent paper, on the sensitised sheet of paper. Lay a piece of glass over the drawing, and press it firmly and evenly down, so as to make every part of the drawing and sensitised paper be and remain in contact. These operations should be carried out in a dark-room; then expose the whole to clear sunlight from 4 to 6 minutes in summer, 6 to 10 in winter, and, in the absence of sunlight, for 30 minutes under a clear sky. Then remove the drawing from the sensitised paper, and pour water over the latter from one to two minutes, so as to thoroughly saturate it, and then hang it up to dry, when the yellowish-bronze colour will become darker, and the lines of the drawing still darker; the sensitised surface becomes of a blue tint, with the lines of the drawing in vivid contrast. Instead of the above sensitising solution, the following mixtures can be kept ready prepared, and mixed when wanted for use:—Solution (*a*): Dissolve 1oz. of citrate of iron and ammonia in 4oz. of distilled water; keep this in a stoppered bottle. Solution (*b*): Dissolve 1oz. of potassic ferrocyanide (red prussiate) in 4oz. of distilled water, and keep in stoppered bottles. When wanted for use in sensitising the copying paper, mix equal quantities of (*a*) and (*b*), and either float a sheet of paper in a bath of the mixture, or else brush or sponge it over evenly. Blue prints obtained by the above process may be changed to brown or green by the following method. To connect blue prints with green ones, make the following solutions. Solution (*a*): A crystal of nitrate of silver as large as a pea, 8oz. of distilled water. Solution (*b*): 1fl.oz. hydrochloric acid, 8fl.oz. water. Solution (*c*): Potassic iodide solution (1oz. potassic iodide, 8oz. of water) saturated solution of bichloride of mercury water. To prepare this solution add as much of the potassic iodide solution to the bichloride of mercury one until the red precipitate is just redissolved, then reduce the resulting solution with four times its bulk of water. Solution (*d*): 1dr. of iodide of potassium, 16oz. of water. Method of usage: Dip the blue print in a bath of solution so as to bleach it until the blue lines turn either a pale yellow or else slate colour; then wash the print thoroughly in water and dip it in solution (*b*). This will restore the blue printing. Next, without washing, put the print into solution (*c*), when the printed lines will be of a green colour; but the "whites" of a yellow colour. Then put the print in (*b*) again, without washing. Next pour solution (*d*) over the print to purify the white, and give the green image a bluer tint. Do not let the print remain in this solution too long, or it will become blue again.

(To be continued.)

H. C. S.

#### CHIPS.

The War Department estimates contain a vote of £66,000 for barracks and other buildings at Pendennis, near Falmouth.

The foundation-stone of a new Wesleyan chapel was laid in the High-street, Ramsey, Hunts, last week. The building will be Gothic in style, and the contract for erection has been taken by Mr. Wade, of St. Neot's, at £1,920.

A new block of buildings is about to be erected at Llandrindod Wells for the London and Provincial Bank, Limited. The directors have instructed Messrs. Wilson and Moxham, architects, Swansea, to prepare the designs.

The North-Eastern Railway Company are about to widen the Leeds and Wetherby Railway, eleven miles in extent, and to construct a short junction line at Wetherby about half a mile in length. This will involve about 200,000 cubic yards of earthwork and the building of no fewer than 30 bridges. Tenders are now being invited.

An Order in Council has been made for the sale of Addington Park, on the ground that it is "expensive to maintain and otherwise undesirable to maintain as an Archbishop's residence." With the proceeds it is proposed to provide a house for the Archbishop within or near the city of Canterbury.

The Whitechapel Picture Exhibition, to be opened on Tuesday next, is expected to be very attractive this year. Among the many works by the late Sir John Millais, which are to be transferred from Burlington House to St. Jude's Schools are "Chill October," "The Old Garden," "Lilacs," "A Message from the Sea," and "Lord Salisbury," and we are informed that the Queen has lent the portrait of the child Princess Marie of Edinburgh, now Crown Princess of Roumania. The exhibition closes on April 17.

CONTENTS.

The Proposed New Government Buildings .....	403
Model Specifications.—V.....	403
Royal Institute of British Architects .....	406
Electric Lighting Notes for Architects.—XIX.....	406
Sanitary Work.—II.....	408
Useful Items for Builders, Plasterers, Painters, Paper-hangers, &c.....	410
The Surveyors' Institution .....	411
Wrought Iron and Steel in Constructional Work.—XXXV.....	411
Copying Processes for Reproducing and Duplicating Drawings, Plans, &c.....	414
The Building News Directory.....	1x.
Our Illustrations .....	415
Books Received .....	434
Professional and Trade Societies .....	434
Competitions .....	434
Building Intelligence .....	435
Engineering Notes .....	436
Intercommunication .....	436
Parliamentary Notes .....	437
Legal Intelligence .....	437
Water Supply and Sanitary Matters .....	438
Our Office Table .....	439
Meetings for the Ensuing Week .....	439
List of Competitions Open .....	440
List of Tenders Open .....	440
Trade News .....	442
Tenders .....	444
Latest Prices .....	445

ILLUSTRATIONS.

WOLVERHAMPTON FREE LIBRARY.—MODEL FARM, COPPED HALL ESTATE, ESSEX.—“QUEEN GUINEVERE” AND “SIR LANCELOT.”—ROYAL FREE HOSPITAL, GRAY'S INN ROAD.—THE CHARTERHOUSE.

Our Illustrations.

WOLVERHAMPTON LIBRARY COMPETITION: SELECTED DESIGN.

THE two accompanying double-page plates in illustration of the first premiated design in this competition were reproduced from the original drawings by Mr. Henry T. Hare, A.R.I.B.A., the author of this plan, chosen by Mr. Alfred Waterhouse, R.A., the referee. It is proposed to face the building with red-brick and buff terracotta dressings. The floors are to be fire-proof. The news-room and magazine-room are intended to be warmed on the “plenum” system, and the other rooms and entrance-hall by radiators. The curved outline of the site and its special surroundings offered no little difficulty in designing a satisfactory building, and the exceptionally large areas stipulated for in the conditions were at variance with the money restrictions imposed upon the competitors. The competition was a limited one, and the nine architects who submitted designs appear as follows in the official report:—Mr. H. T. Hare, A.R.I.B.A.; Mr. J. M. Brydon, F.R.I.B.A.; Mr. Maurice B. Adams, F.R.I.B.A.; Mr. W. H. Bidlake, Birmingham; Mr. W. Henman, Birmingham; Mr. W. Martin, Birmingham; Mr. F. W. Simon, Edinburgh; Mr. F. T. Beck, Wolverhampton; and Mr. G. H. Stanger, Wolverhampton.

FARM BUILDINGS AT COPPED HALL, EPPING, ESSEX.

THESE buildings, the property of Mr. Ernest J. Wythes, J.P., recently inclosed for the home farm at Copped Hall, occupy a central position for the working of the farm on high ground, conveniently placed for roads and water, and within a few hundred yards of the mansion. The home farm consists of some 600 acres of heavy clay land (mostly grass), and the new buildings, which have been planned for dairying and breeding purposes, cover an area of 25,000sq.ft., and are capable of housing 120 to 150 head of cattle, the accommodation consisting of 56 standings for tied cattle, 19 boxes for in-calvers, calves, and bulls, and covered yards to hold about 35 head of cattle. There are also two mixing floors (with chaff floors over), two granaries, with space for about 400 quarters of corn, various storehouses, cart and implement sheds, nag-horse stables (two stalls and one box), and coachhouse and piggeries. Detached from the main building, and at a convenient distance from the cowhouses, there is the separator house, also men's mess-room, fowl-houses, sick-box, more piggeries, boiling-house, meal-store and slaughter-house, the whole being substantially built of red brick, roofed with Staffordshire tiles, with the exception of the covered yards, where the open-boarded system has been adopted, the boards being crea-

soted, grooved, and placed  $\frac{3}{4}$ in. apart. The plans and views will show the arrangement and style of the buildings. Entering from the stackyard on the north side through a wide archway under the granary, are the mixing floors on either side, with chaff-shoot and steps to floors above and sliding doors leading to the feeding gangways, which run down the centre of the long ranges of cowhouses, the gangway at the upper end continuing round to the piggeries and range of boxes on the south side of the building. It will be noticed that the position of the mixing floors is convenient for the stack-yards and granary, as well as for feeding, and it may be pointed out that the open space in the centre of the buildings makes the covered yards particularly “light and airy without being draughty”—this is, of course, a matter of great importance to owners of cattle. In the making of covered yards this is overlooked, and that is why they are so often carried out unsatisfactorily. The floors of all the cowhouses, boxes, and gangways are laid with granite concrete and grooved, and the whole of the drainage is conducted into a liquid-manure tank under the cartshed at the lower end of the buildings, from whence a chain-pump delivers it into carts for distribution on the land. The drainage was made easy by the natural fall of the ground, which amounts in the length of the building to upwards of 12ft. The floors of the various cowhouses, boxes, &c., are placed in different levels to suit the fall of ground, and steps in the buildings are happily avoided altogether by sloping the gangways, &c. The upper cowhouses have iron fittings filled in with oak, carrying a shell-shaped drinking-trough for each beast, the water supply being by gravitation from large pond near. The mangers to these houses are of stoneware, the fronts being faced with brown and white glazed bricks, with oak capping; other mangers and troughs throughout the buildings are of concrete. Loading and unloading corn, &c., is made easy by double-lift hand-hoists, and the hoists being in the centre of the floors under the archways, the work can be carried on in all weathers. It should be mentioned that the cart-horses are kept in a separate set of buildings elsewhere on the farm, where also the cutting of chaff, grinding, &c., is carried out by steam power, the latter being used also for electric-lighting purposes. The agent is Mr. P. W. Dashwood, and the clerk of works is Mr. Geo. W. Johnson, who acted as architect. The farm steward is Mr. J. B. Ormond.

NATIONAL PRIZE DESIGN FOR STAINED GLASS WINDOWS.

THE subjects of “Lancelot” and “Guinevere” are chosen for this work now being executed. The intention in “Sir Lancelot” is to express remorse for his love of Guinevere. In the background, the Vision of the Holy Grail appears. In “Queen Guinevere” it is endeavoured to express the extreme contrast, by her regal and gay attire, with the solemn character of the monastic surroundings which are suggestive of her future. These cartoons were awarded a National Book Prize last year to their author, Mr. Henry Osipov, of Kensington.

THE ROYAL FREE HOSPITAL.

THE Royal Free Hospital, Gray's Inn-road, W.C., is an institution in every respect free, and it is situated just where a hospital of the kind is most needed. The locality is one of the poorest and most densely populated in the Metropolis, containing 61 per cent. of the poorest classes, and 297 persons to the acre. Since its foundation in 1828, the Royal Free Hospital has relieved the destitute sick to the number of 2,221,880. Of course, the hospital soon required more room, and in the year 1842 it was removed from Greville-street to the site it still occupies in the Gray's Inn-road. Having no endowment, the governors were forced to be content with some old barracks in the former occupation of the Light Horse Volunteers. A welcome addition was made, however, by the Freemasons of England on the death of the Duke of Sussex, their late Grand Master. They erected the “Sussex” wing to his memory, placing a statue of his Royal Highness in front. This wing was opened in 1856, and six years later the freehold of the hospital was purchased, chiefly through the zeal and ability of the then chairman of the hospital committee—the late well-known philanthropist, George Moore. Fifty beds were subsequently added, when another wing, the “Victoria,” was built in 1876, out of a large sum bequeathed by the

late Rev. John Gautier Milne. In addition, a large out-patient department (including waiting-rooms for men and women, a dispensary, and a covered way communicating with the rest of the building) was also erected. Owing to the receipt of considerable legacies, further accommodation was provided next year—the nurses' quarters, isolated wards for patients, a large lecture-room, private rooms for the medical staff and the students, a museum, *post-mortem* theatre, mortuary, and a number of store-rooms and other essential adjuncts to the hospital. By this the bed accommodation was brought up to 160, and the hospital equipped throughout on the very best lines for the comfort of patients and nurses alike. So far, we have spoken mainly of the new wings. All that remains of the old barracks are the casualty rooms, dispensary, drug-stores, laboratory, the resident medical officers' quarters, and the steward's, housekeeper's, and servants' rooms. The committee decided three or four years ago to rebuild the whole of the front at a cost of £20,000, by Mr. W. Harvey, F.R.I.B.A., the architect of the hospital, and this has now been completed, as seen in the accompanying view, lent us by the architect. The centre quadrangle has some well-grown trees in it, and on a pleasant summer day convalescent patients may be seen taking a welcome airing on the seats in the shade. As for the wards, they are more than usually large and airy, while the quantity of flowers displayed on the tables in the centre give them a most home-like and charming appearance, soothing, indeed, to weary patients longing to be at liberty. There are also plenty of pictures and ornaments, all of which contribute to the same end. The nursing staff is large and capable. This leads us to refer to one extremely important point in connection with the management of the Royal Free Hospital—its association with the London School of Medicine for Women. We believe this is the only hospital in England whose doors are open to lady students. Here these ladies are enabled to obtain actual clinical experience of the greatest value; and the outcome has been the placing of many of them upon the Medical Register; others have taken the very highest honours at the London University. Over 2,000 poor sick persons are annually treated, not to speak of the advice and medicine administered to nearly 25,000 out-patients—all gratuitously—at an annual cost of about £11,500 per annum, of which only some £2,500 is assured.

CHARTERHOUSE SQUARE.

We give herewith the general plan, &c., which we promised on page 301, when we fully described and partly illustrated Mr. Walter H. Bourne's careful and useful drawing of this famous old foundation.

CHIPS.

A Local Government Board inquiry will be held at the Council House, Bristol, to-day (Friday), in reference to an application by the corporation of that city to borrow £43,000 for the extensions decided upon at the Stapleton Lunatic Asylum.

At a vestry meeting held at Bury St. Edmund's last week, it was reported that the roof of St. Peter's district church was very insecure, and needed restoring, while the organ is beyond repair. It was decided to raise funds for a restoration fund.

Mr. Lionel Cust, director of the National Portrait Gallery, will to-morrow (Saturday) afternoon, at 3 p.m., deliver the first two lectures at the Royal Institution on “Portraits as Historical Documents; Portraits as Monuments.”

The contract for the construction of the extension of the City and South London Railway from Stockwell to Clapham Common is said to have been placed. This extension, which is to be completed in fifteen months, with the opening of the company's line to Moorgate-street, now being rapidly pushed on, will, it is confidently expected, open a new era of prosperity for the company.

In the Chancery Division on Tuesday, Mr. Justice Stirling gave judgment in an action, “Allhusen v. the Ealing and South Harrow Railway Company,” in which the plaintiff, the owner of a mansion-house known as Twyford Abbey, sought to compel the defendants—who had given notice to treat for the purchase of a small portion of a private road forming the approach to the house for the purposes of their railway—to purchase the whole of the property. His Lordship refused the plaintiff's motion for an injunction, holding that the land which the defendants sought to acquire would not pass under conveyance as part of the plaintiff's house.

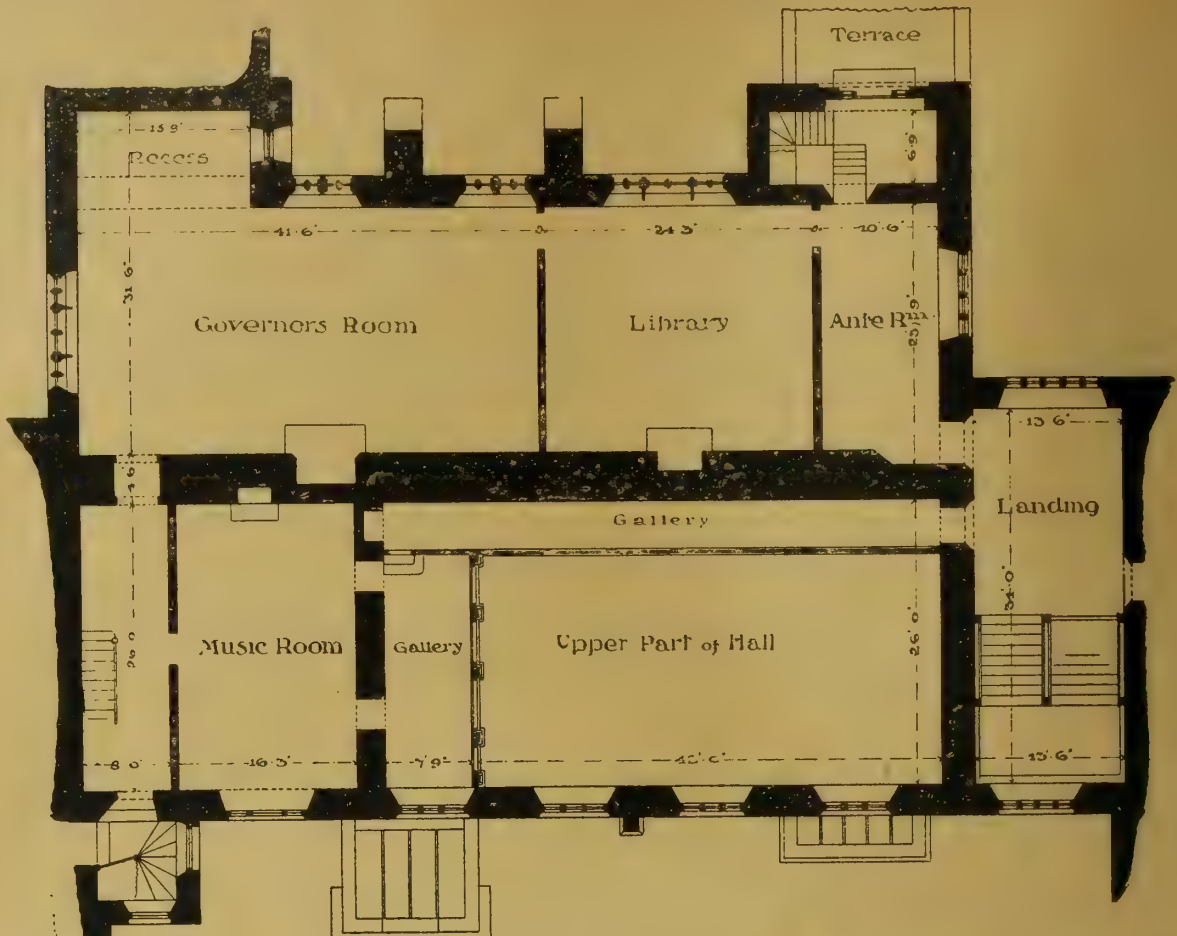

First Floor Plan

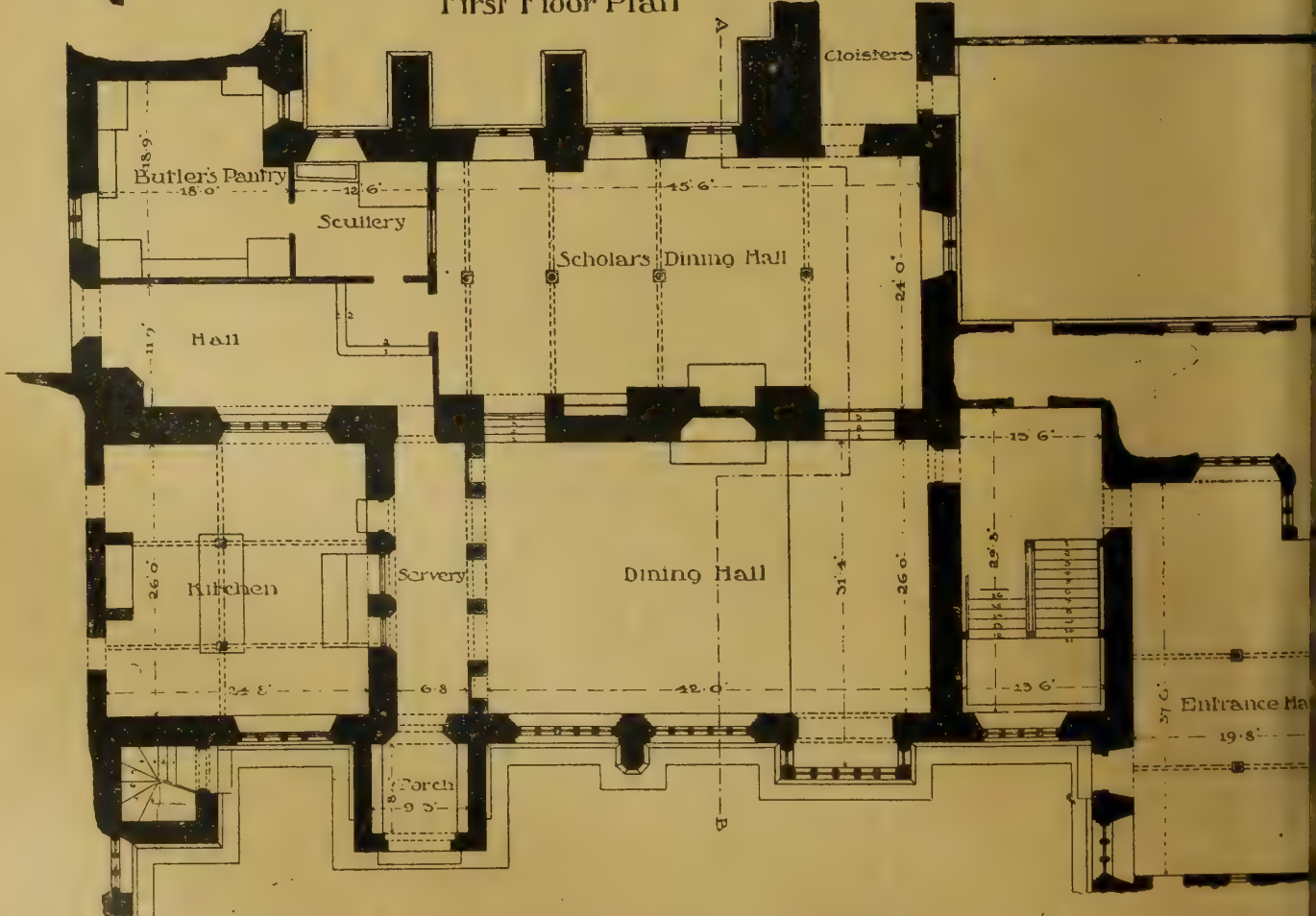

Ground Plan

Scale of Feet



# THE CHARTERHOUSE

MEASURED & DRAWN BY WALTER H BOURNE



Elevation of Dining Mall etc  
(facing Masters Courtyard)

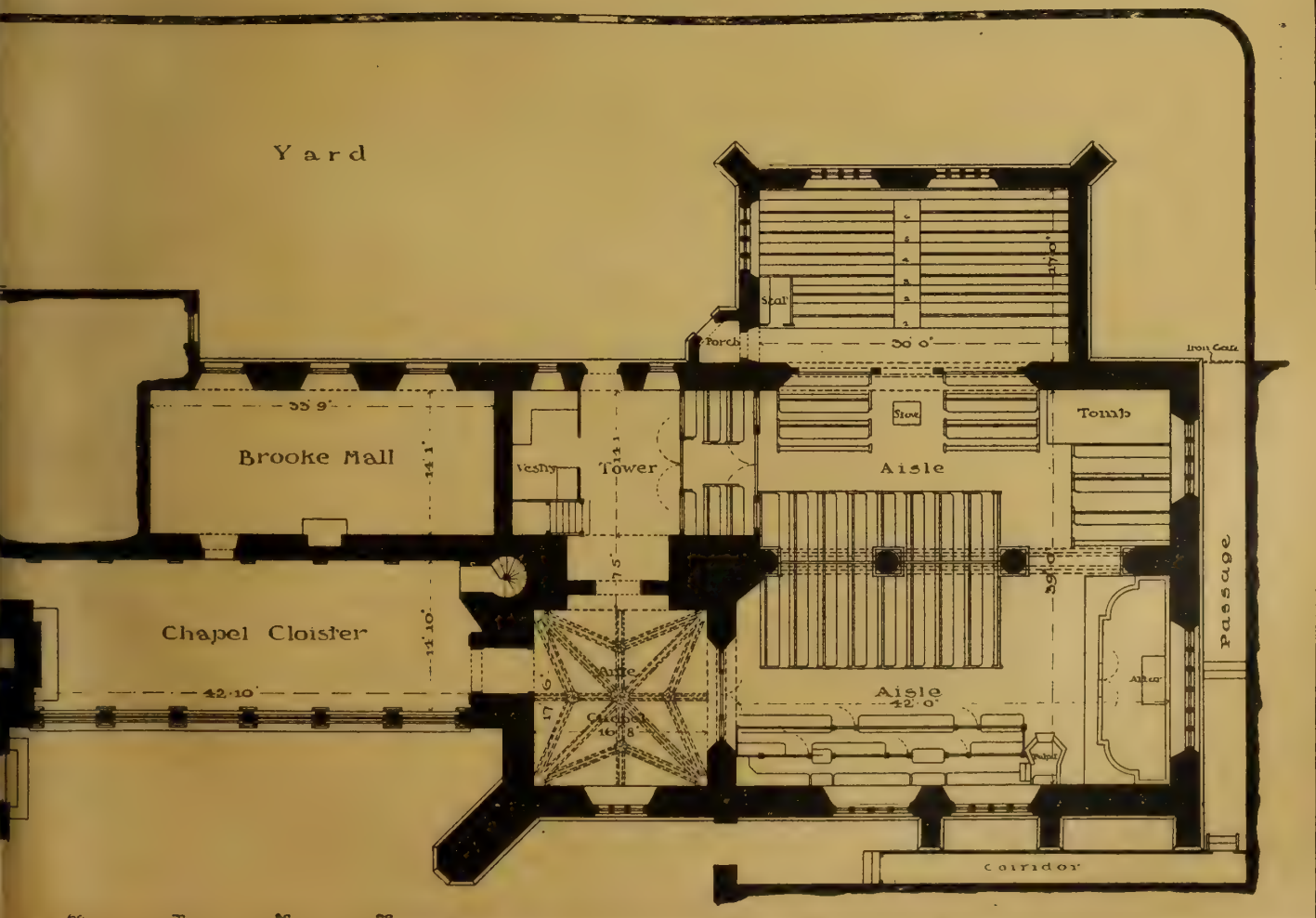

## BOOKS RECEIVED.

*Norwich Cathedral* is succinctly described and excellently illustrated in the handy volume just published as one of Bell's Cathedral Series of monographs on the English minsters (London: Geo. Bell and Sons). The book on Norwich is written by Mr. C. H. B. QUENNEL, and contains forty illustrations from drawings by Mr. S. K. Greenslade, and photographs, and also a clearly engraved plan. A history of the fabric is given, it being shown that the cathedral occupies the site of no earlier church, and that to-day, in plan and general bulk of detail, it is as characteristically Norman as when left finished by Eborard, the second bishop. Its distinctive features, the long nave, the grand apsidal termination encircled by a processional path, the segmental chapels to north and south of the apse, the centrally-placed bishop's chair and westward position of the throne are dwelt upon. The Close gates are described and pictured, and supplemental chapters deal with the sees of the East-Anglian bishops and the city itself. Everyone interested in our church architecture—and what educated man or woman is not?—ought to possess this cheap and well got-up series of handbooks.—*The Cathedral Church of Peterborough*, by the Rev. W. D. SWEETING, M.A. (London: George Bell and Sons), is another of the excellent handbooks published in Bell's Cathedral Series, of which we have noticed many. It is only necessary to add to our former notices that this handbook is compiled from the best and latest sources, such as Gunton's "History of Peterborough," Craddock's "History," the monographs of Professor Paley, Mr. Poole, and Canon Davys. The work is divided into six chapters, which deal with the history of the cathedral church of St. Peter, the exterior, the interior, the Minster precincts and City, History of the Monastery and of the Diocese. There are nearly 50 illustrations, many of these being clear reproductions of photographs by the Photochrom Company, Ltd., and Messrs. S. B. Bolas and Co. Other illustrations are from sketches by Messrs. H. P. Clifford, W. H. Lord, and A. R. Allbrow. The views of the apse and new buildings, the triple-gabled west front, and the interior are excellent. Reference is made to Mr. Pearson's restoration of the north gable, and to the controversy which raged so furiously some time ago. To all students and visitors this handbook will be a valuable guide.—*Sponsors' Architects' and Builders' Price-Book*, 1898, edited by W. YOUNG, architect (London: E. and F. N. Spon, Ltd., Strand), retains its useful alphabetical arrangement, and has been carefully revised and brought up to date by the insertion of a chapter on electricity, with a complete specification and estimates of electric-lighting installations; also notes on lightning conductors, electric bells, and memoranda on concrete fire-proof floors, &c. The notes and memoranda on ancient lights, architects' charges, floors, girders, measurements of work, stones, approximate cost of buildings, besides those of each trade, make this book, as we have said before, a textbook of general use, as well as a price-book.—We have received a third edition of *Willis's Workmen's Compensation Act*, 1897 (London: Butterworth and Sons, 7, Fleet-street). This reliable handbook, by Mr. W. ADDINGTON WILLIS, LL.B., is supplied with copious notes, and has an appendix giving the Employers' Liability Act of 1880. A new feature in the edition is an analysis of a proposed scheme to be certified under the Act of last session, and a form of application for a certificate.—The last quarterly issue of the *Essex Review* (Chelmsford: E. Durrant and Co.), contains illustrated articles on "The Hawys of Saffron Walden," by Algernon R. Goddard, and on "Essex Brasées," by Millar Christy and W. W. Porteous.

A group of labourers' dwellings at Liverpool, which have been erected for the accommodation of those who have been dispossessed of houses by the action of the Insanitary Property Committee of that city, are now ready for occupation, the rents ranging from 2s. 6d. to 3s. 6d. a week, the corporation paying rates and taxes.

The building trade throughout North Staffordshire is in a flourishing condition, and there is every prospect of a continuance of the same, cottage property for artisans being in great request. At Burslem bricklayers report a small percentage out of work, but joiners are well employed. In Hanley all branches are busy, with none out of employment. A similar remark applies to all the other pottery towns.

## PROFESSIONAL AND TRADE SOCIETIES.

YORK ARCHITECTURAL SOCIETY.—At the meeting on Friday evening of this body, Mr. C. H. Channon, of Malton, delivered a lecture on "Old Malton Priory," illustrated by measured drawings, and showed a conjectural restoration, developed from actual data, describing what the building would be like in its original and pristine grandeur. The church, he said, is interesting as being the only one of the Gilbertine Order remaining in which public worship is still held. It was founded in 1150 by Eustace FitzJohn. The Gilbertines sheltered Thomas à Becket during his flight from the King's wrath. Of the twenty-six Gilbertine monasteries suppressed by Henry VIII., twelve were in Lincolnshire, the home of the Order, five in Yorkshire, three in Cambridgeshire, and the rest distributed singly in the Midland counties. Everyone of these, with the exception of that at Malton, has entirely disappeared, and thus this little Yorkshire town possesses a church unique in character, and valuable as a national monument. Mr. George Benson occupied the chair. At the close of the lecture, Mr. A. Pollard proposed, and Mr. A. B. Burleigh seconded, a vote of thanks to Mr. Channon.

The widening of Cherry-street at a cost of £12,300 has been agreed to by the city council of Birmingham.

A new organ for the Presbyterian Church, Bristol, has just been completed by Messrs. Hele and Co., of Exeter and Plymouth. Special services in connection with the opening of the organ have just been held.

A new church of St. Silas, which has for some time been in course of erection on a commanding site in Preston New-road, Blackburn, will be ready for opening after Easter.

The Lower Mosley-street Schools, Manchester, built in 1836, are about to be demolished, the site being required for the new Great Midland Hotel. A new and larger building has been erected on the other side of Lower Mosley-street at a cost of £5,700, and is on the point of completion.

The tomb of the Duke of Clarence and Avondale, in the Albert Chapel at Windsor Castle, is now being completed. A recumbent statue of the Duke is to be placed upon the lid of the Mexican onyx sarcophagus containing the coffin, and the Royal burial place will be surrounded by bronze railings.

Professor Charles Eliot Norton will retire from the Department of Fine Arts in Harvard University at the end of the present academic year. Professor Norton has had, for the last thirty years, a very great influence upon American artistic ideas. His courses of lectures at Harvard University have been extremely popular, attracting usually more than four hundred registered attendants.

The urban district council of Sheerness have applied to the Local Government Board to sanction a loan of £13,700 for the construction of a new iron pier in place of the wooden structure which was built in 1833 and partially destroyed in the gale of Nov. 29.

At Edmonton County-court, on Friday, an action was brought by a bricklayer, named Gardner, of Westmacott-street, Camberwell, against Knight and Son, builders, Tottenham, to recover damages under the Employers' Liability Act, for injuries sustained through negligence of defendants' servant whilst the plaintiff was employed by them in carrying out internal alterations at the Crown and Shears public-house, Sparrow-court, Minories, E.C. A verdict was returned for plaintiff for £50 and costs.

The Bill for the construction of the City and Brixton Electric Railway, which the City and South London Company have agreed to work in perpetuity, came, on Friday, before a special committee of the House of Commons. It was practically unopposed, and was passed by the committee subject to the insertion of clauses to be arranged with the St. Saviour's District Board of Works. The proposal is to provide stations at Brixton Hill, Lorne-road, Kennington Oval, Kennington Cross, St. George's-circus, and King William-street; and the City and South London Company will have connections at the Oval and at the Borough. Sir Benjamin Baker is the engineer.

A new hospital is about to be built by Lord Forester near the railway-station at Wenlock, on a site of four acres. Mr. A. Balfour is the architect.

A meeting of the Conway and Colwyn Bay Water Board was held on Friday to consider the claim of the engineer, Mr. T. B. Farrington, C.E., for £2,000 for services rendered. The board offered £1,600, which was declined, and the matter remains in abeyance for a month.

## COMPETITIONS.

ALTRINCHAM, CHESHIRE, PUBLIC OFFICES.—In competition for this building, to cost £4,000, 26 architects sent in designs. The council requested Mr. John Ely, F.R.I.B.A., president of the Manchester Society of Architects, to act as assessor, and this award was before their meeting on the 18th inst., when it was found that the first place was given to the design "Vox Populi," by Messrs. Chas. A. Hindle, A.R.I.B.A., and H. Davenport, of Monton, near Manchester. The second place is taken by "Altrincham," by Mr. J. Macnamara, of Altrincham. Before opening the assessor's award, the council passed a resolution deciding to adopt the design placed first. This is an excellent procedure, and would give confidence to competitors if more generally adopted. The designs are to be exhibited in public.

## CHIPS.

A Free Church and lecture-hall are about to be built in St. John's-road, Tunbridge Wells, from plans by Mr. Galey, of that town.

A destructive fire occurred on Friday night in an extensive house carpentry yard in Ayr, and the whole premises and stock of timber were burnt out. The loss is estimated at £5,000.

In aid of the effort which is being made to fill with statues the niches which adorn the beautiful west front of Beverley Minster, Professor Woodberry, of New York University, has forwarded a cheque for £35, the cost of two statues, as a contribution from the Historical Society of Beverly, Massachusetts, of which the professor is the president.

The official view with regard to the desire of the Museums Committee that they should be consulted in connection with the changes at South Kensington is that the demand is inadmissible, as the plans must be left to be settled by experts. It is probable that it will be some time before they are framed, and the building operations may extend over two or three years.

The London School Board discussed at their last meeting a proposal of the School Management Committee to set apart £100,000 in the coming year for the purpose of improving old schools. An amendment was proposed to refer the matter to the Works and Finance Committees to bring up the whole scheme, with an estimate of the total cost; but after discussion this was rejected, and the original motion was adopted.

Mr. E. Druce, who superintended the building of the Admiralty Pier at Dover on behalf of the Government and was in charge of the structure until it was handed over to the Dover Harbour Board several years ago, died suddenly on Tuesday at his residence in Victoria Park, Dover.

The fine organ of St. James's Church, Piccadilly, originally built by Renatus Harris for the Chapel Royal, Whitehall, and given to St. James's Church by William and Mary in 1695, has been for some time under repair by Messrs. Bishop and Sons; it was reopened on Tuesday evening by Sir Walter Parratt.

The prizes offered by the Corporation of the City for the best designs for a medal to commemorate her Majesty's Diamond Jubilee have just been awarded:—First prize, £20, to Messrs. Spunk and Son, Gracechurch-street and Piccadilly; second prize, £15, to Mr. J. Gamble, 24, Rich-terrace, South Kensington; and third prize, £10, to Mr. A. B. Sykes, 16, Perry-hill, Calford. There were 16 designs sent in, and 14 were accepted for competition.

The Deritend Branch Free Library at Birmingham, which has been partially reconstructed and extended, was reopened on Saturday afternoon by the Lord Mayor. The old building was ill-lighted and ill-ventilated, and the accommodation was very inadequate; but now a lengthened, light, and commodious news-room and library have been provided. The total cost of the alterations was £1,500. Mr. J. A. Cossins, of Birmingham, was the architect for the enlargement.

The Plumstead Vestry are about to commence the sewerage scheme for Shooter's Hill district, and also to construct an underground convenience for both sexes by Plumstead Railway Station, in accordance with plans prepared by their surveyor, Mr. W. C. Gow.

New offices for the school board of Newport, Mon., have just been built in Charles-street in that town. The buildings, which also include a pupil teacher's centre, are English Renaissance in style, and are faced in red brickwork, with red Mansfield stone for dressings. Messrs. Conyers, Kirby, and Son, of Newport, are the architects, and Mr. J. Linton, is the contractor. The outlay has been about £6,000.





MODEL FARM  
COPPED HALL ESTATE ESSEX

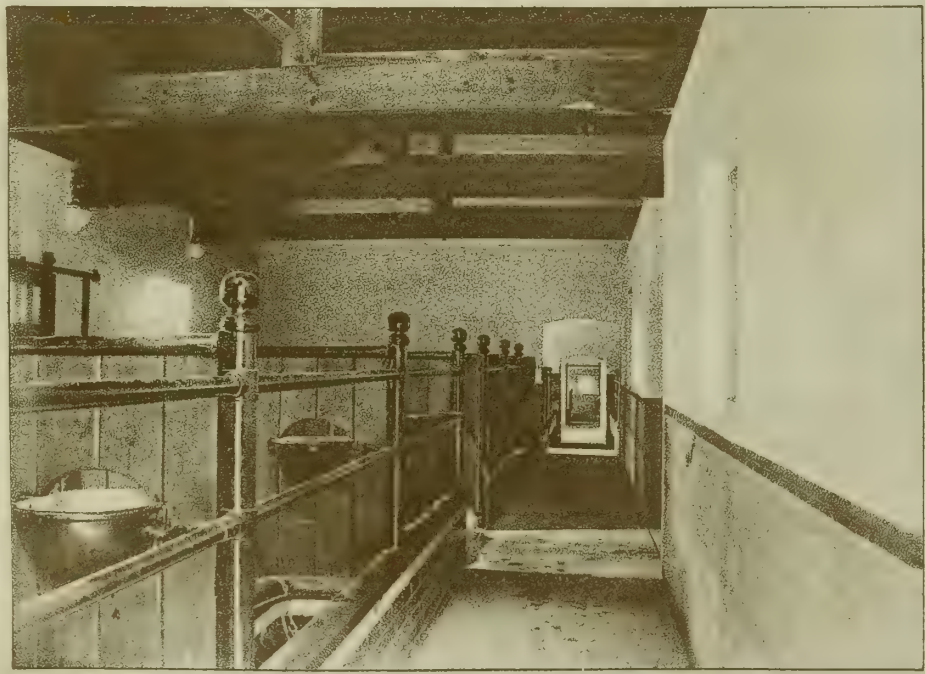

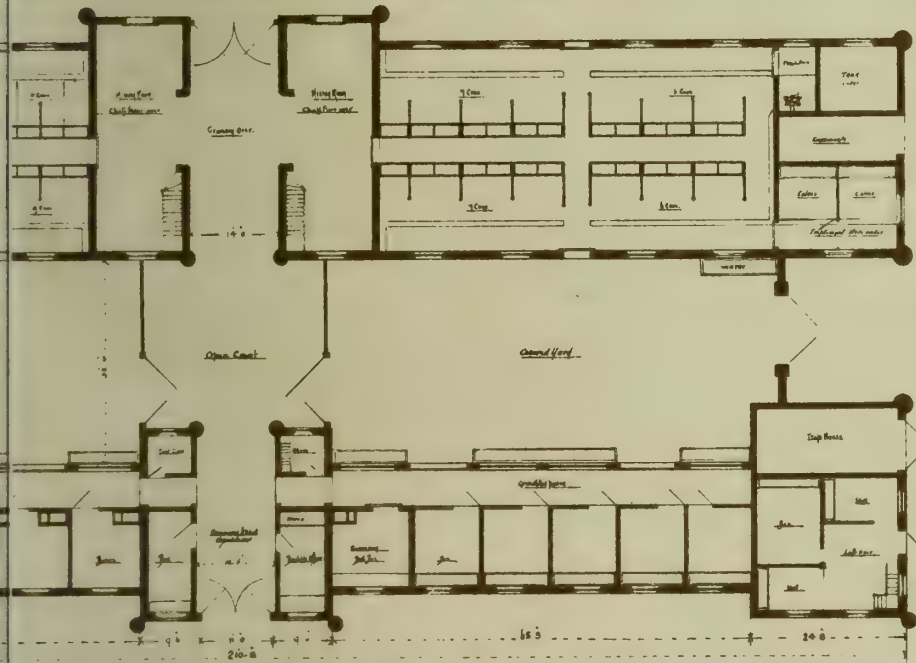

GEORGE W. JOHNSON ARCHT



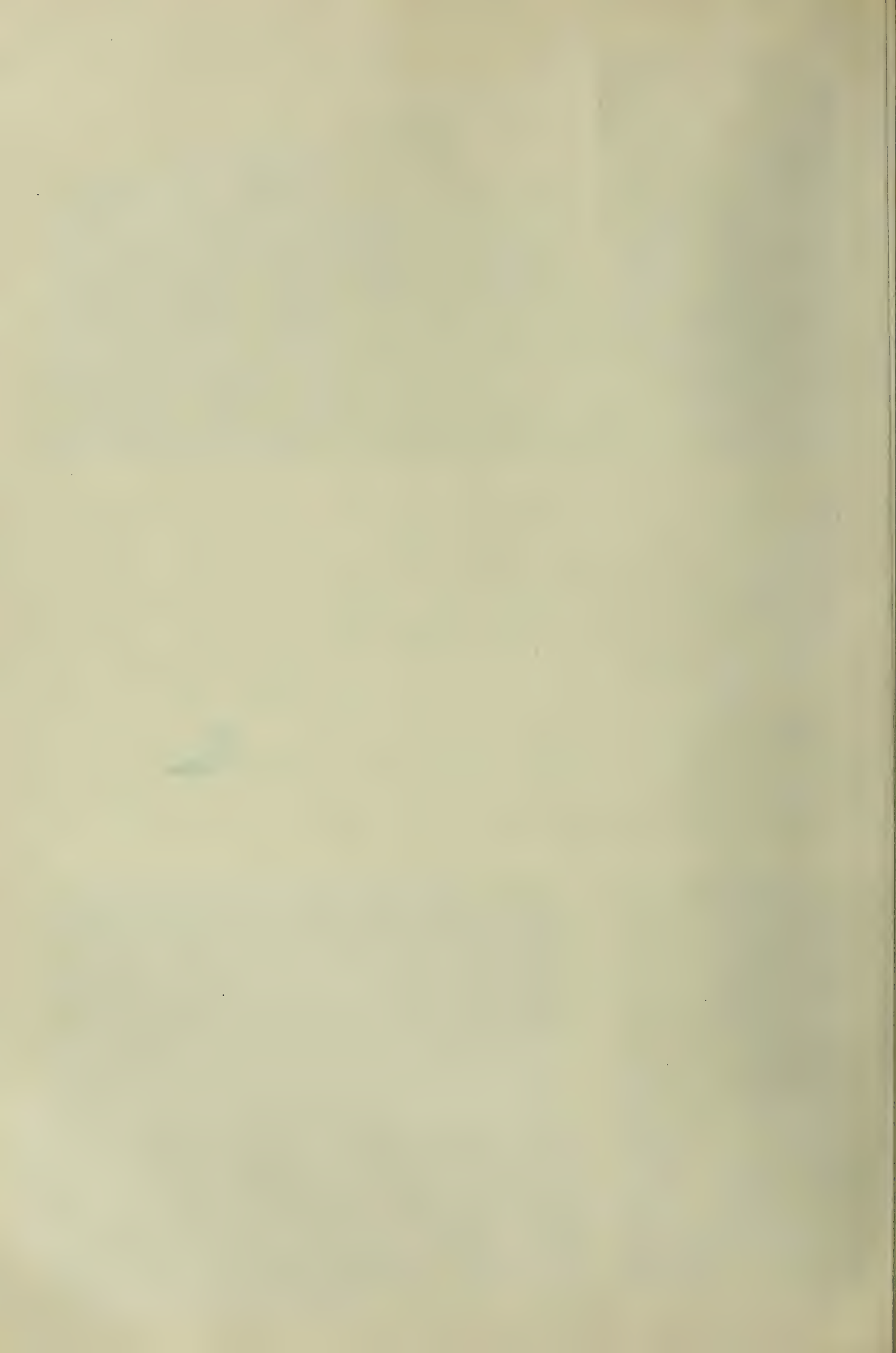



# WOLVERHAMPTON: FREE LIBRARY:

SELECTED DESIGN.

H. T. HARE ARCHITECT.

SCALE OF FEET

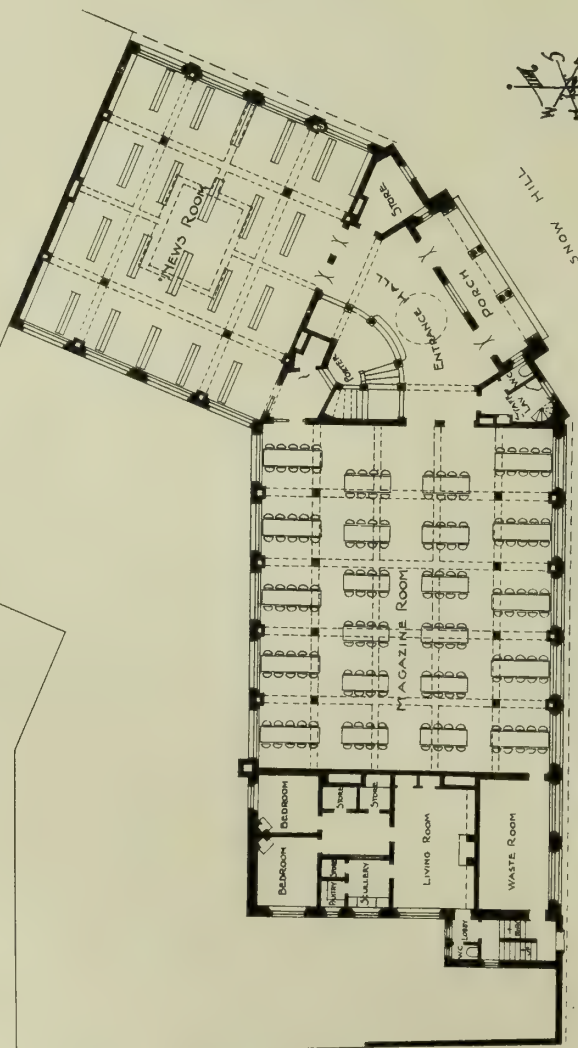

GROUND PLAN

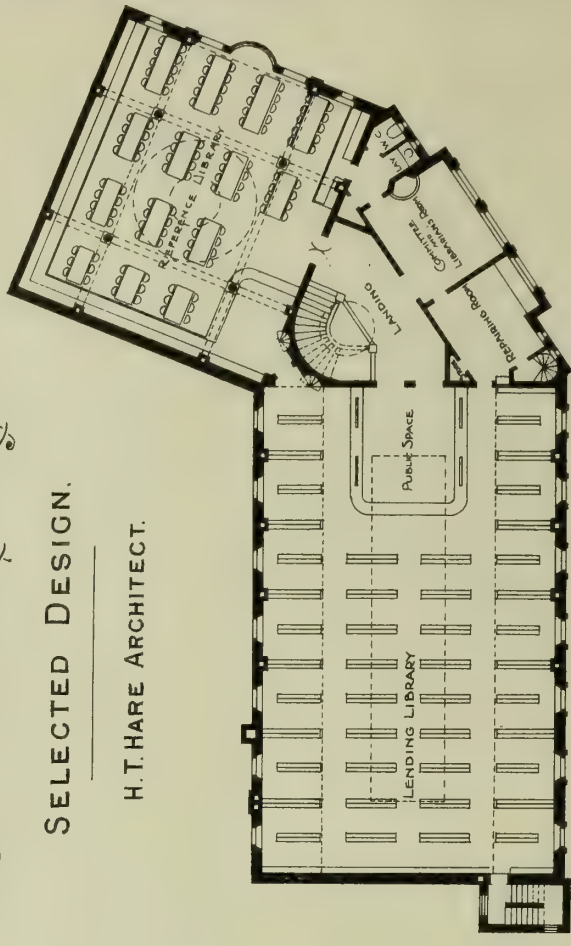

FIRST FLOOR

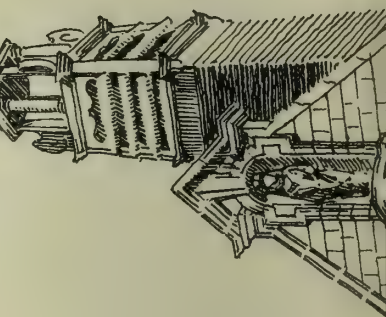

Vertical text on the right edge of the page, likely a page number or reference code.



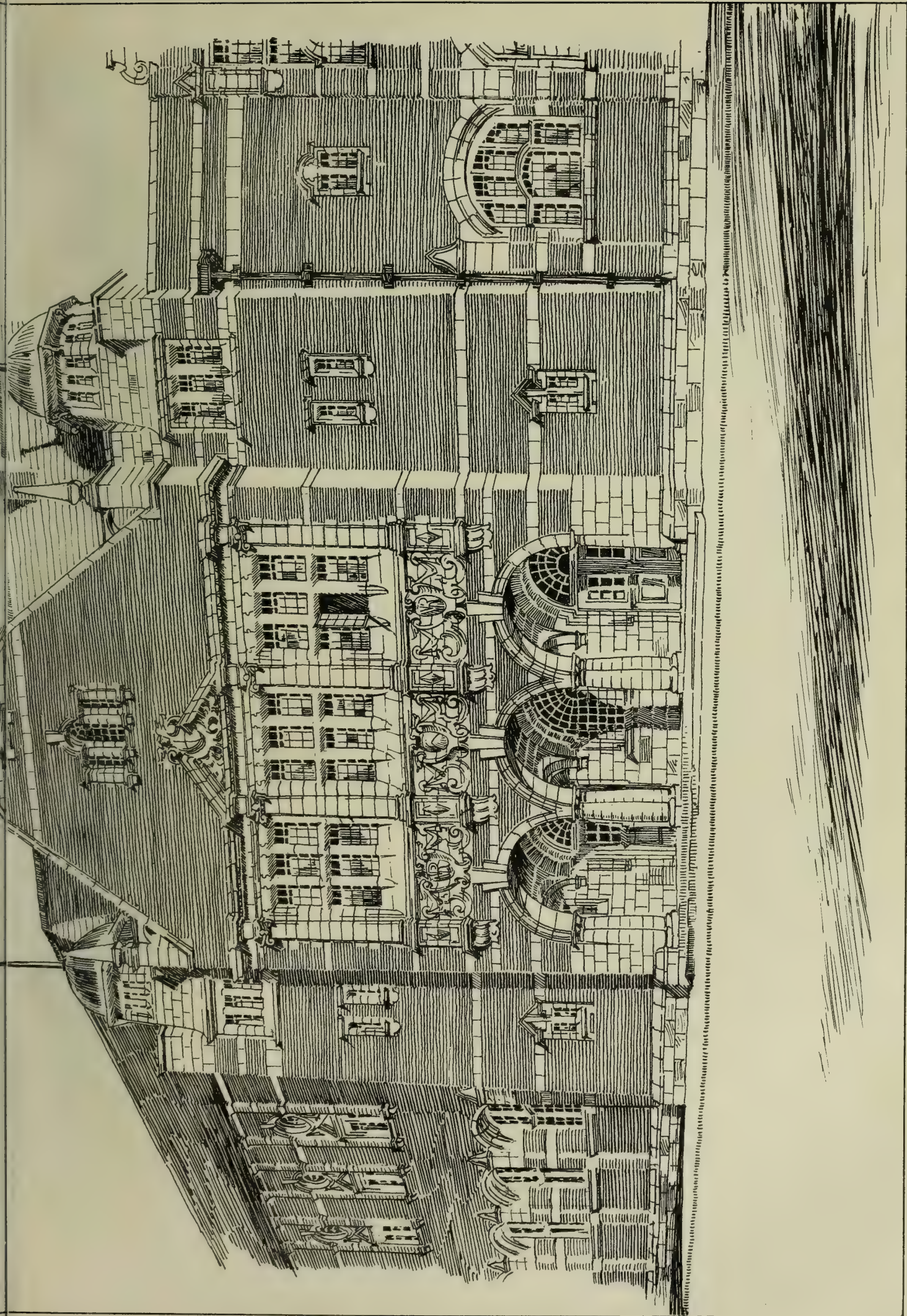
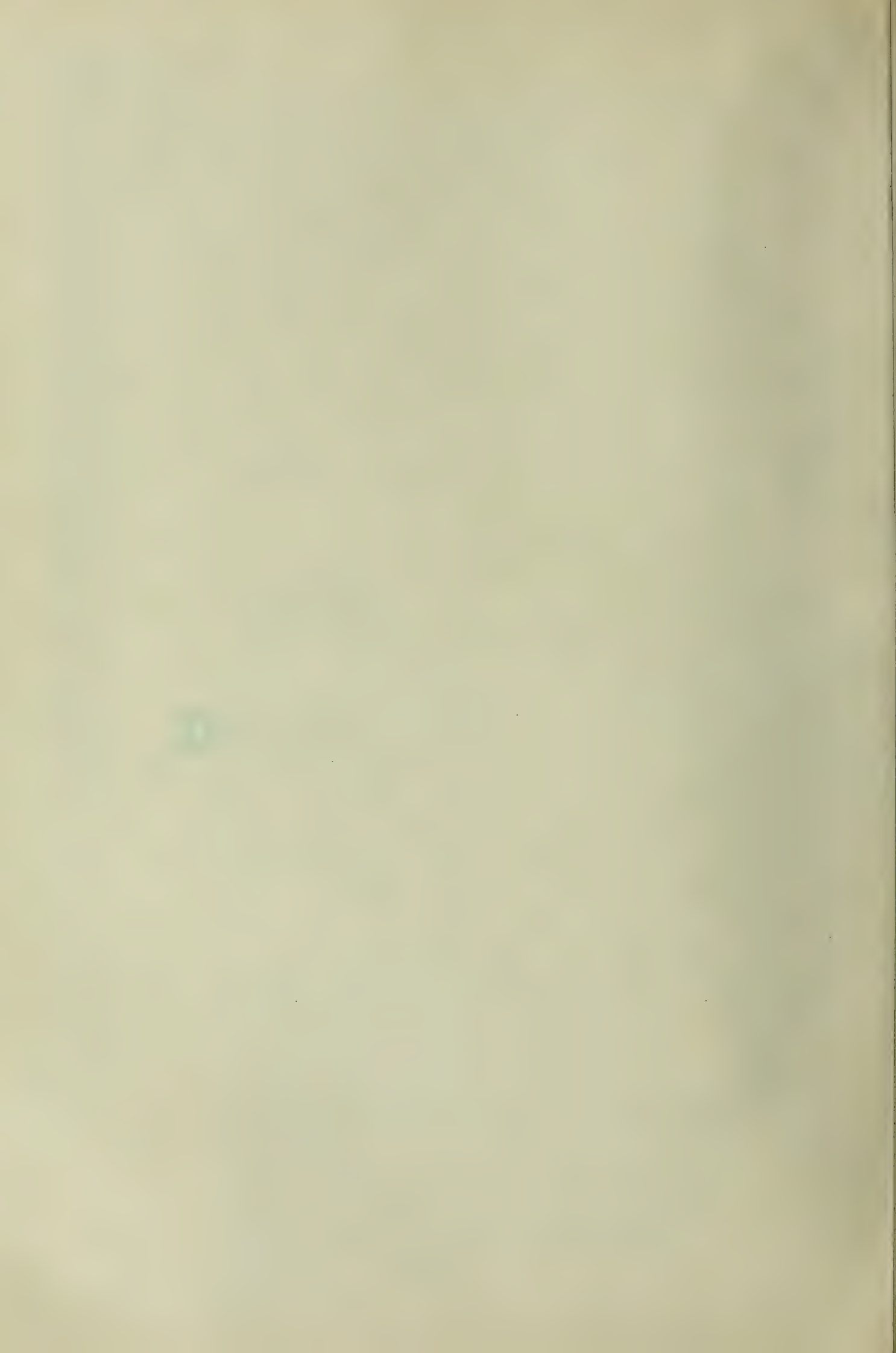

Photo-Lithographed & Engraved by James Akerman, 6 Queen Square, W.C.





: COUNTY BORO  
: PROPOSED FR

SE

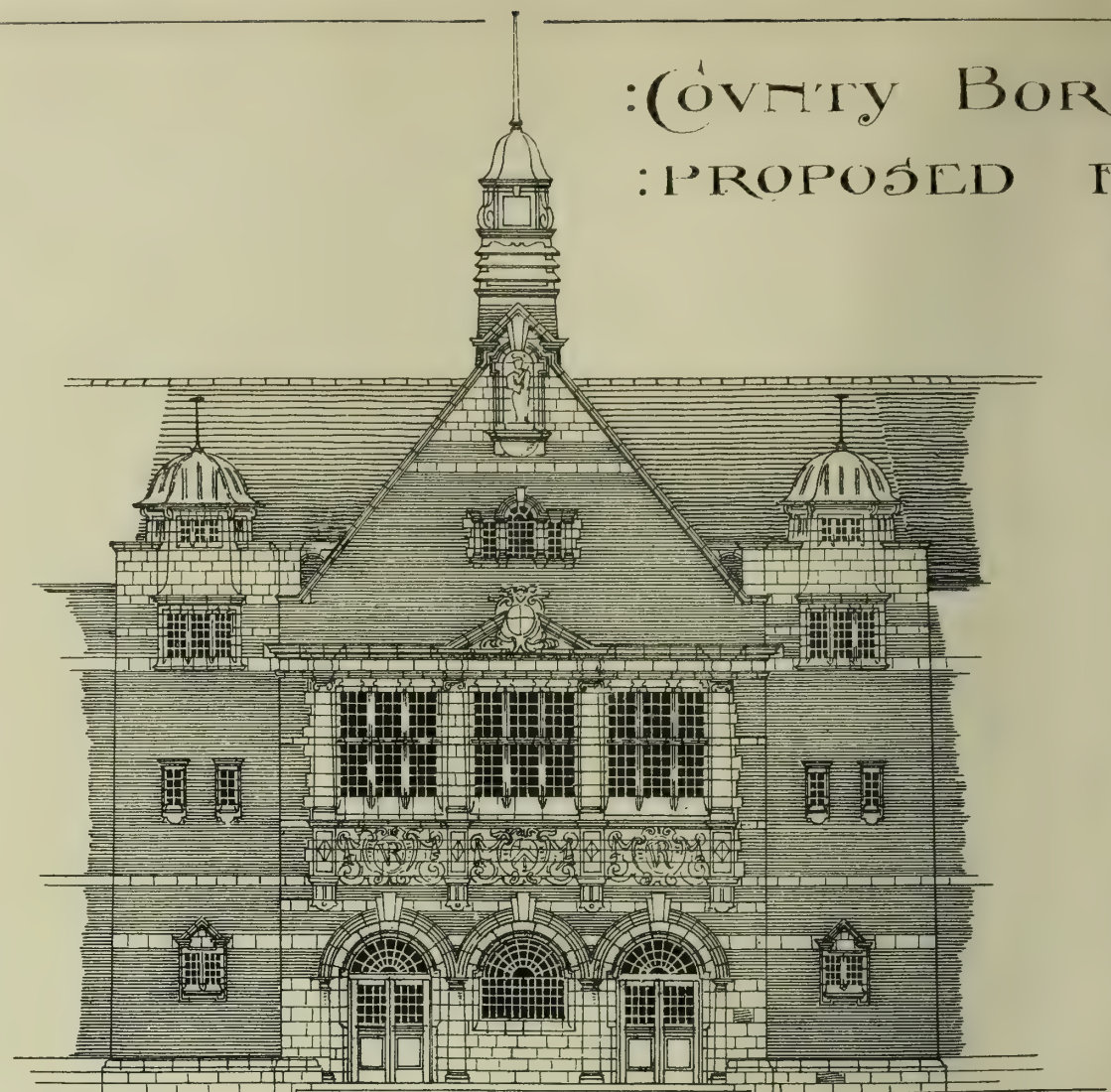

Elevation to Snow Hill:

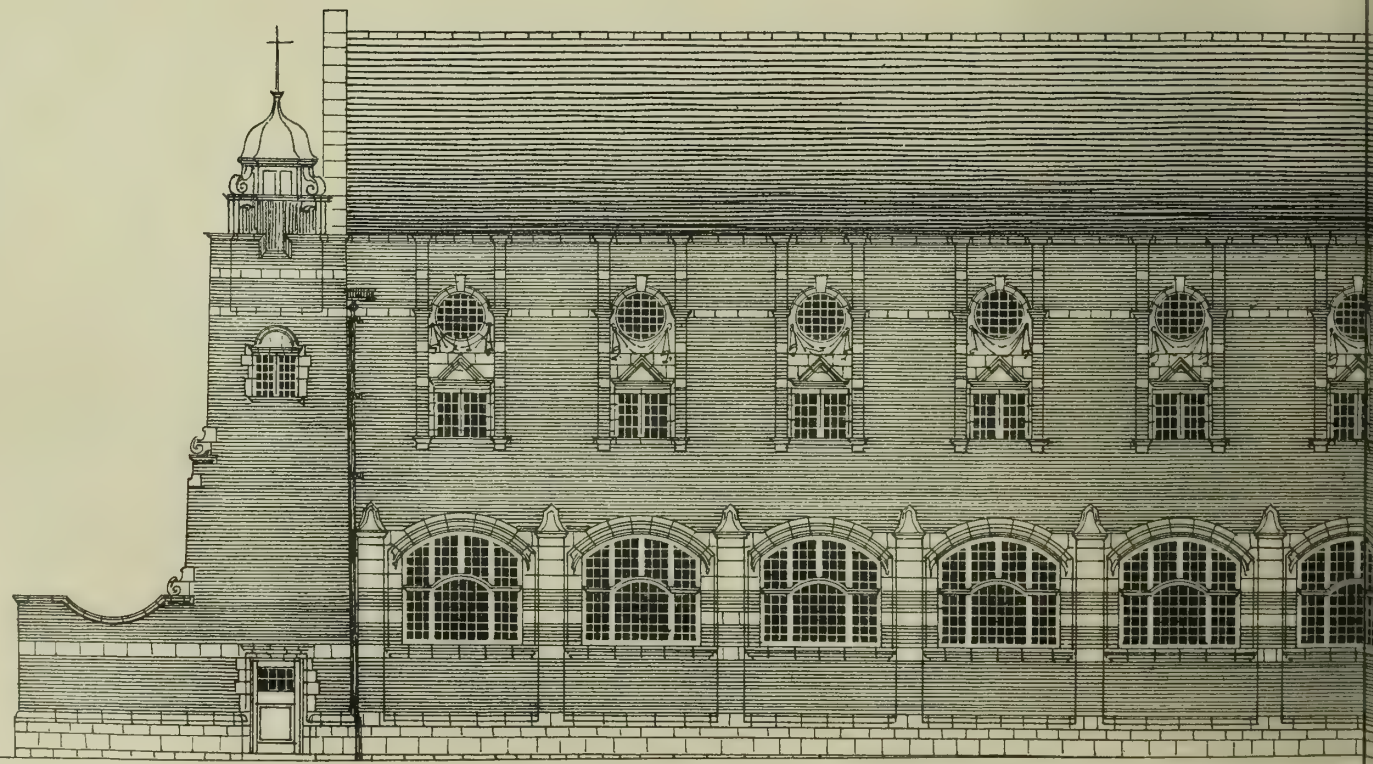

Elevation to Garrick St.

# UNIVERSITY OF WOLVERHAMPTON: FREE LIBRARY:

SELECTED DESIGN.

W. T. HARE, ARCHITECT.

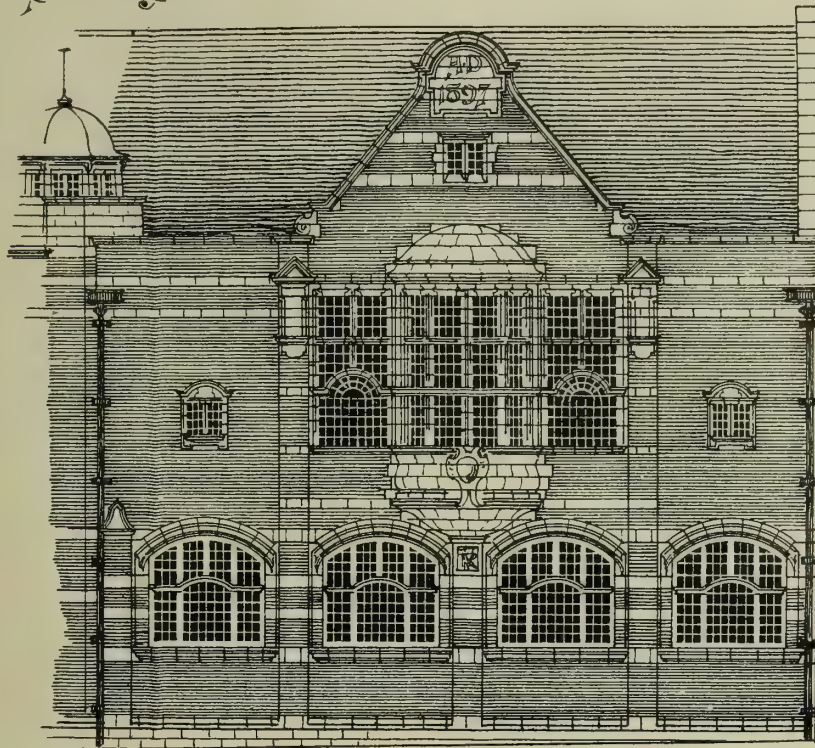

Elevation to Cleveland Rd

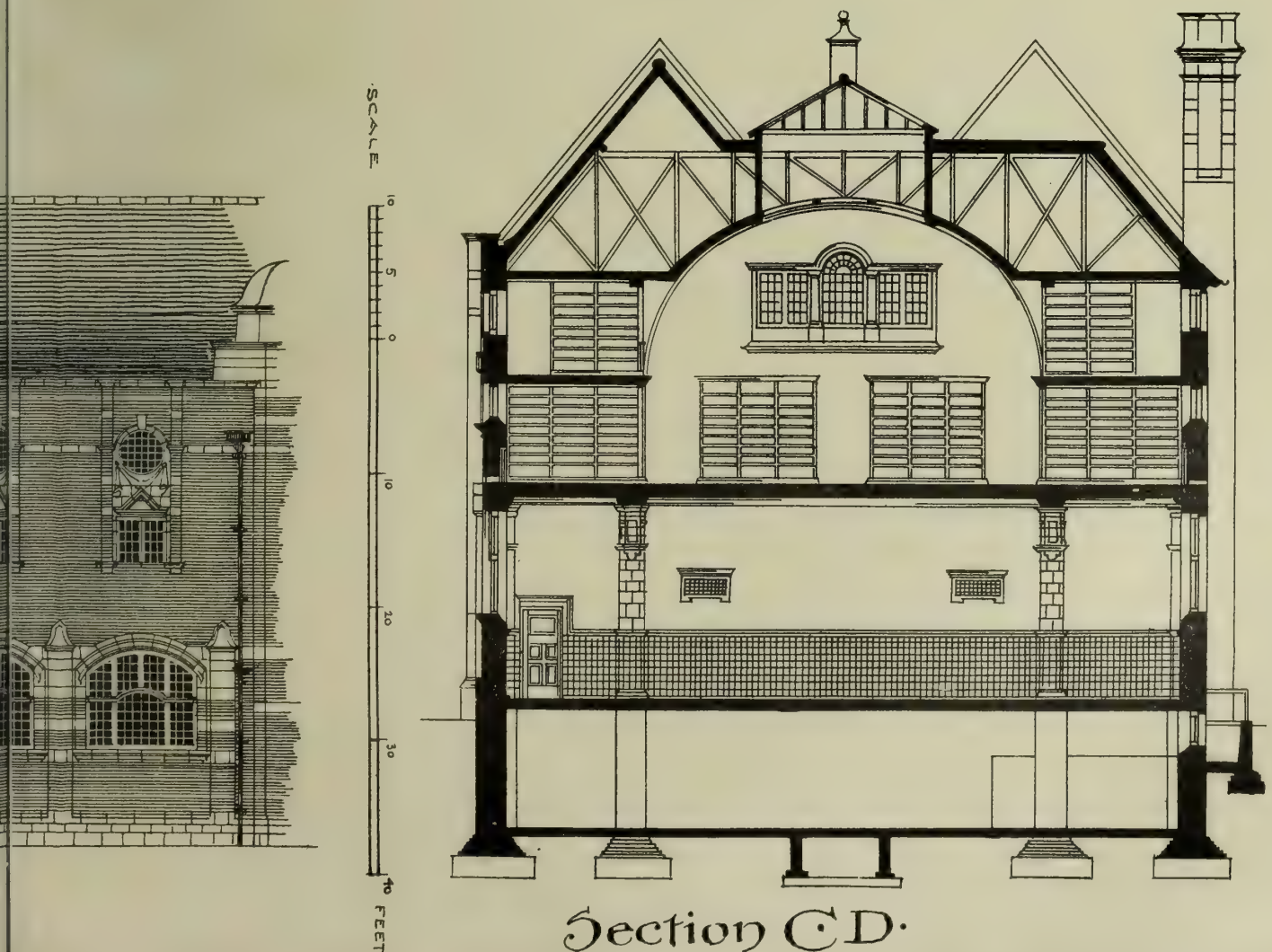

Section C.D.

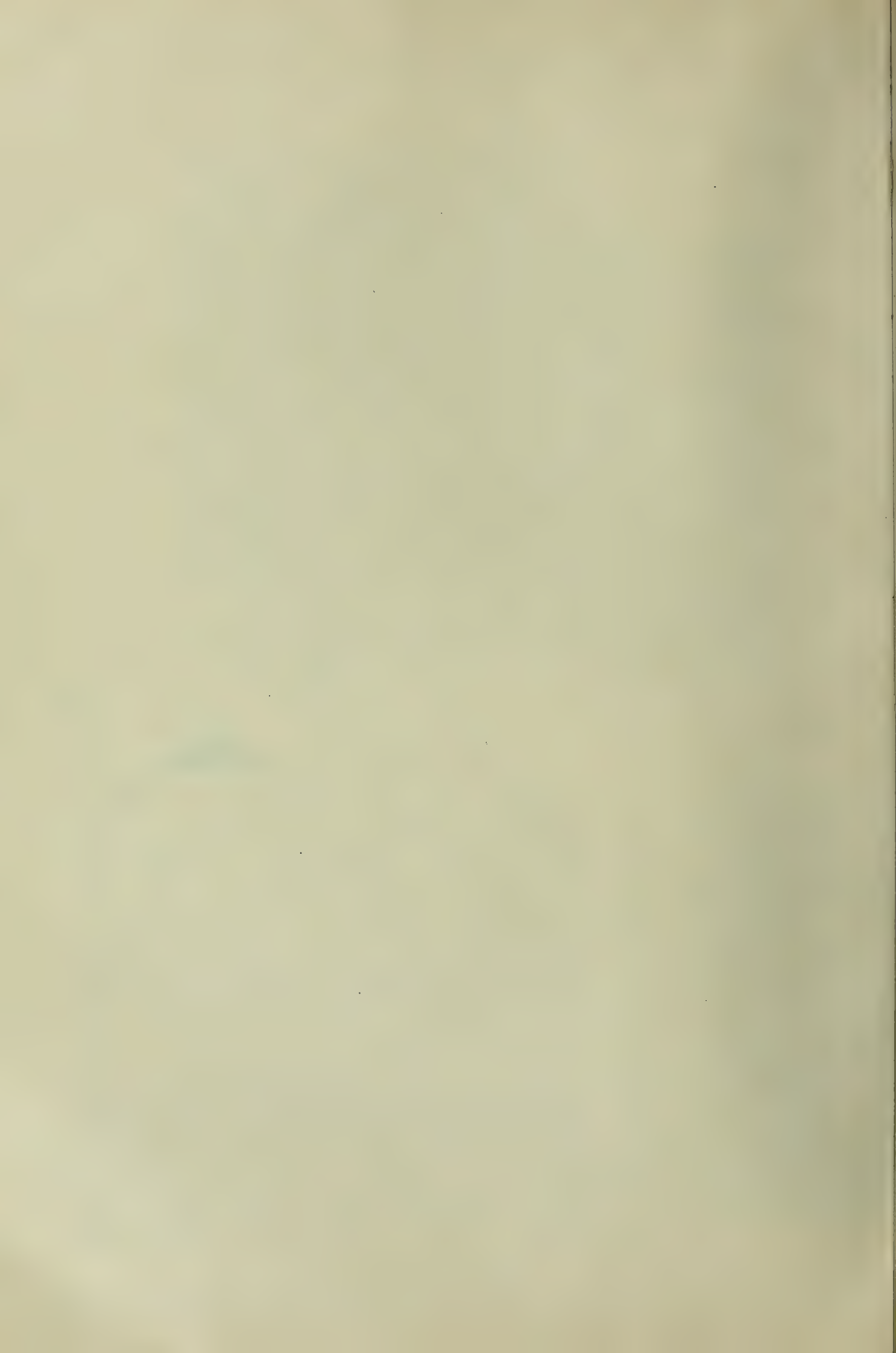





PHOTO-TINT: by Jane Assman 8 Queen Square London W.1

QUEEN GUINEVERE

SIR LANCELOT



THE BUILDING NEWS. MAR. 25, 1898.

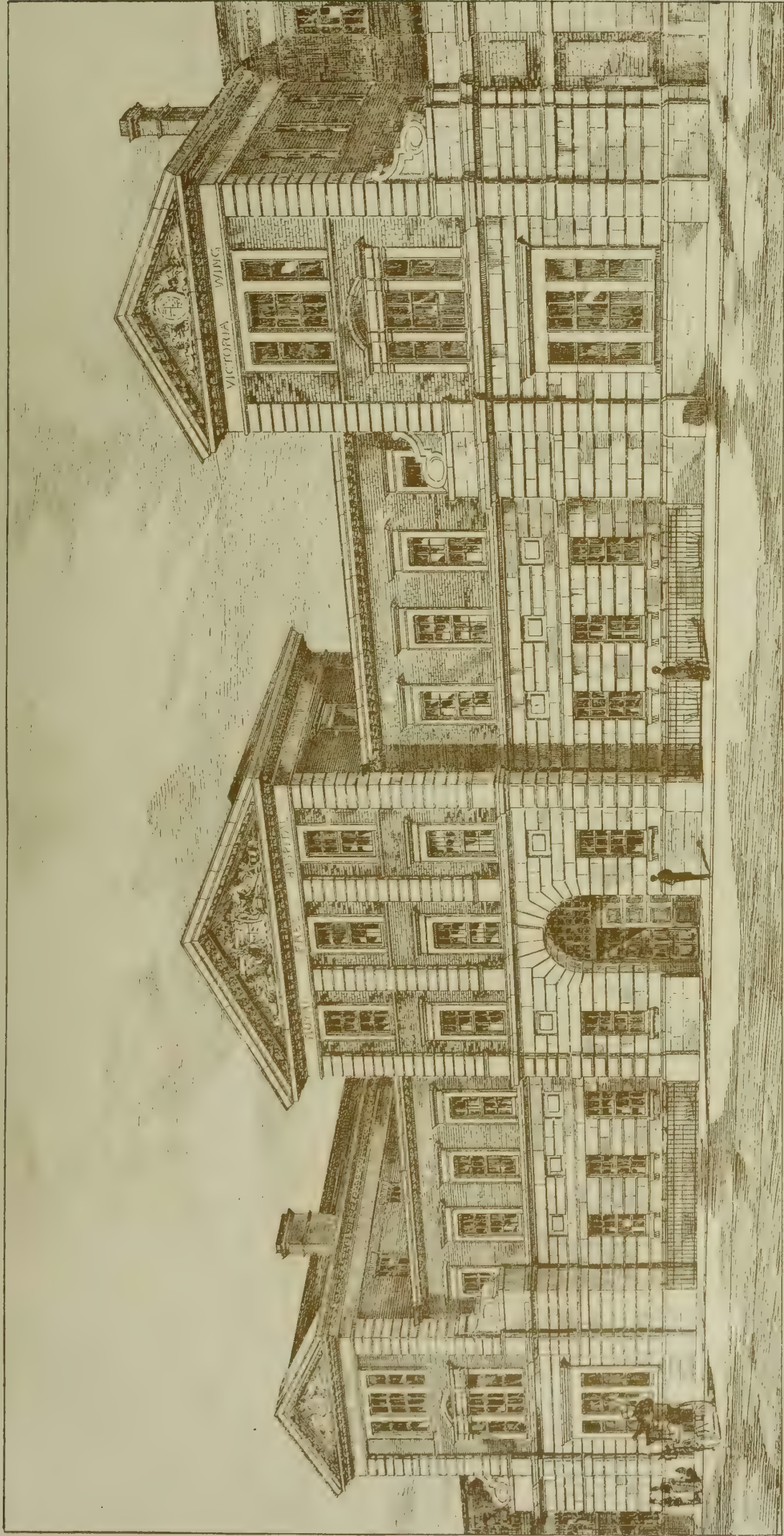
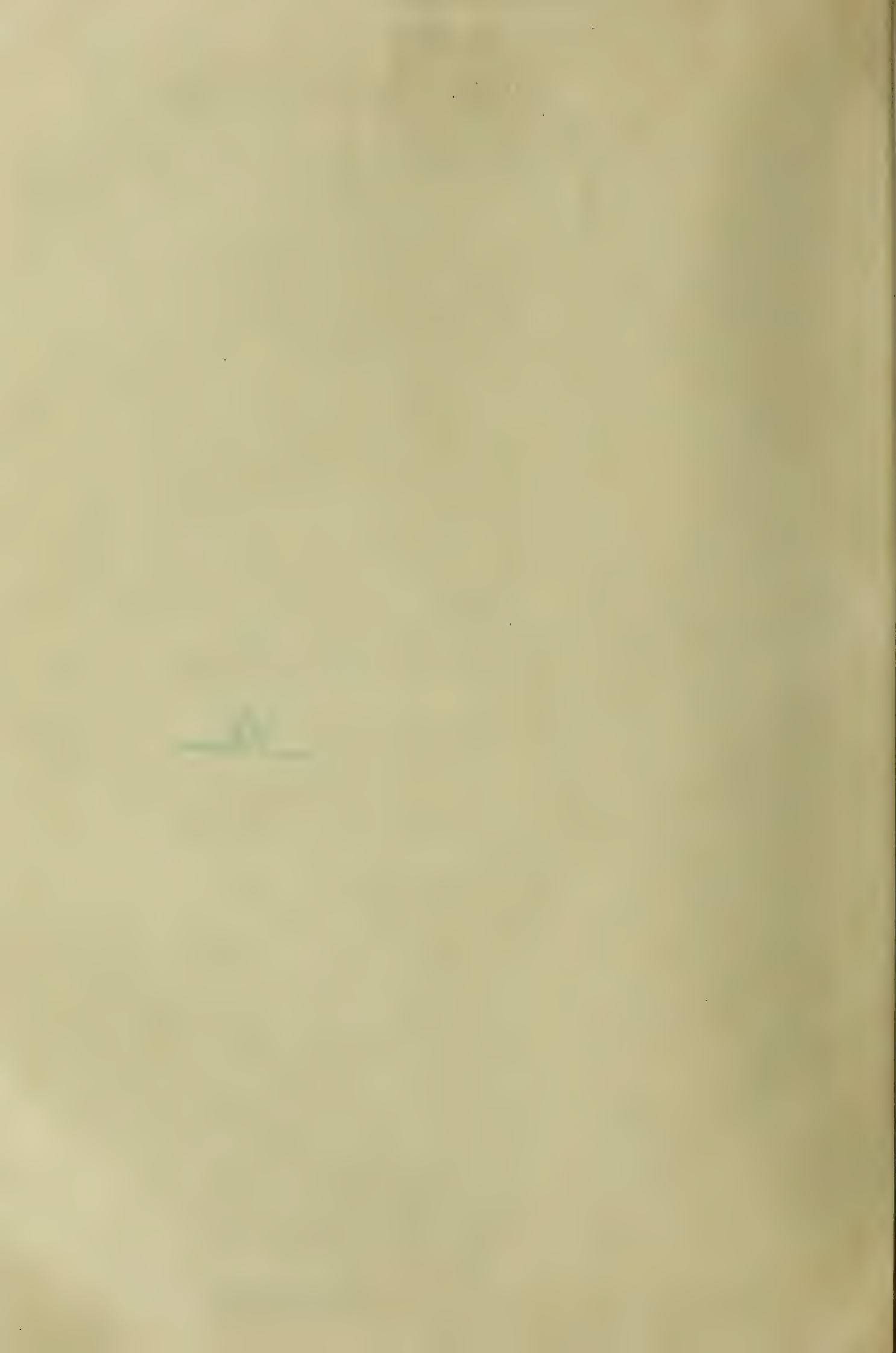

Photo Lithographed & Printed by James Akerman, 25, Queen Square, W.

ROYAL FREE HOSPITAL · GRAYS' INN ROAD · FRONT BUILDING · W. M. HARVEY ARCHT.



## Building Intelligence.

**ARMLEY, LEEDS.**—A Methodist New Connexion Chapel in Hall-lane, Armley, was opened last week. The total cost of the chapel and the adjoining Sunday-school, which has been open since September last, has been £3,850. The site of the buildings covers an area of 925 square yards. The style adopted is a plain treatment of Gothic. The chief external features are a tracery window in the front gable and a square tower with octagonal spire. The chapel, which consists of nave and side aisles, is 52ft. long by 39ft. wide, a deep recess behind the pulpit forms the organ and choir-chamber, and over the vestibule is a small end gallery. A clerestory runs the whole length of the nave, supported by iron columns and wrought-iron stanchions, filled with wood framing, and leaded lights. Between the columns are plastered, moulded arches. The woodwork is of yellow pine, varnished, the pulpit and communion railings being of English oak. The chapel provides accommodation for 410 persons. The school, situated behind the chapel, consists of a central hall, 52ft. long by 28ft. wide, out of which five classrooms open. The minister's vestry and a caretaker's house are placed between the chapel and the school. In the basement is a room for cooking. The architect is Mr. W. S. Braithwaite, of South Parade, Leeds.

**BIRMINGHAM.**—A new theatre is about to be provided for Birmingham, on the site now occupied by the circus in Corporation-street, from plans by Mr. Frank Matcham, of London. The Corporation-street frontage will be devoted to eight shops, with either residential chambers or offices above. The property on the Dalton-street side will be utilised as warehouses and business premises. The stage, at the James Watt-street end of the site, will be 70ft. wide by 45ft. deep, with dressing-rooms, scene-dock, dynamo-room, &c. The pit, which will be on the floor level, will provide accommodation for 800 persons, with 150 stalls in front. The dress-circle and stalls will be reached by a vestibule and staircase in marble and mosaic, opening out at the corner of Corporation-street and Ryder-street. A novelty will be noted in the placing of the five private boxes at the extreme back of the circle, though there will almost of necessity be a couple of stage boxes in the accepted position. The dress-circle will seat 275 persons. A lounge and promenade will extend from the ends of the circle to the stage boxes on either side, fronted with alcoves. The refreshment buffet will be reached through a foyer, and beyond will be erected a conservatory, arranged as a winter garden. In the upper circle, and in the gallery above, the accommodation will be on proportionate lines, and refreshment rooms and cloak-rooms will be provided for each section of the audience. The scheme of decoration will be Moorish throughout. The cost of the buildings is estimated at £50,000 or £60,000.

**CLERKENWELL.**—On Friday evening the Lord Mayor paid a state visit to the building in St. John-street-road, Clerkenwell, known as the Northampton Institute. The foundation-stone was laid on July 9, 1894, and the gymnasium, swimming-bath, large public hall, library, reading room, and workshops are now in occupation. The site is  $\frac{1}{4}$  acres in extent, and is triangular in shape, the apex of the triangle resting upon Northampton-square and the base upon St. John-street-road. The block of buildings in St. John-street-road contains the main entrance in the centre, on the north the large hall, and on the south a four-story building, chiefly consisting of rooms devoted to the social and recreative work of the institute. The northern side of the triangle, extending from St. John-street-road to Northampton-square, along Lower Charles-street, consists of the buildings which contain the bath and the gymnasium, each of which is 120ft. long. The former has dressing-rooms beneath, and the latter has over one end of it a three-story building devoted to educational work. The southern side of the triangle, in Ashby-street, contains a five-story building devoted to educational purposes. These buildings inclose a courtyard, from which the inner rooms and corridors derive their light. The various floors are reached by three staircases placed at the angles of the triangle formed by the courtyard. Over the main entrance there is a tower supporting a bracket clock, and containing in the belfry a heavy peal of bells forming the

chimes and hour-bell of the clock. The architect for the building was Mr. E. W. Mountford, of Buckingham-street, Strand, and the cost has been about £80,000.

**COCKFIELD HALL.**—The works in the partial rebuilding and enlargement of Cockfield Hall, Yoxford, East Suffolk, the seat of Sir Ralph Blois, Bart., which have taken upwards of two years and a half in execution, have just been completed. The new entrance hall is open from the ground floor to the first-floor ceiling, and has an arcaded gallery at the first-floor level. On the ground floor the hall is subdivided by an arcade of three wide arches, access to the first floor being by a wide staircase, elaborately treated and carved. The reception-rooms all open into the hall, and are fitted up in harmony therewith. The ancient Tudor wing remains intact, the portions pulled down being comparatively modern additions, of no architectural interest. The mansion has been redecorated throughout. The work has been executed from the designs, and under the superintence, of Mr. E. F. Bishopp, of Ipswich, architect and diocesan surveyor. Mr. Alfred Brown, of Braintree, was the contractor.

**EDINBURGH.**—The range of new conservatories which has been erected at the Royal Botanic Gardens, Edinburgh, was opened on Sunday for the first time. The range of glass buildings has a frontage of 340ft., and the main building, which is on the west side, is open from end to end for that length. At right angles to it, on its east face, are four conservatories, 64ft. in length by 24ft. in breadth; and rising over the central house is a dome with annexe, around which the other buildings are grouped. The first of these buildings on the south is devoted to the culture and exhibition of stove plants, the second to orchids, the third to economic plants, and the fourth to succulents and plants from dry regions. A new system has been adopted in the Botanic Garden conservatories for the last year or two—viz., to set the plant or shrub in the earth and not confine its roots within the limits of a pot or tub. The plants grow much larger, send out fresher foliage more frequently than under the old plan, and give to the houses a more furnished appearance. The cost of the erection of the new greenhouses has been over £2,000.

**FOREST HILL, S.E.**—Work is about to be begun upon the Horniman Free Museum, Lordship-lane, which its founder, Mr. Frederick J. Horniman, M.P., intends to present as a free gift to the inhabitants of the district. The building will consist of two galleries, each upwards of 100ft. long, lighted from the top. In addition, there will be a lecture-hall, having a seating capacity for 300 persons. Altogether the museum, including the administrative block, will be some 300ft. in length; its front will be constructed entirely in stone, and there will be a clock tower over 100ft. in height. The galleries will be divided into various courts, each devoted to a separate class of the objects of which the museum proper consists. Thus there will be a pre-historical court, an Egyptian court, an Indian court, a colonial court, a Japanese court, and so forth, while there will be special departments for the zoological and entomological specimens as well as for the library. Fifteen acres of land surrounding the dwelling in which the collection is now housed will be converted into a public park and recreation ground, while Surrey Mount, an existing mansion therein, is to be fitted up as a free library and clubhouse. Mr. C. Harrison Townsend is the architect of the new museum.

**LEEDS.**—A Home and Schools for Blind and Deaf Children is being erected by the Leeds School Board in Blenheim-walk, off Woodhouse-lane. The building, the plans of which have been prepared by Mr. W. S. Braithwaite, of Leeds, will cover an area of 1,200 square yards. The style is a free treatment of Gothic. The structure will be three stories high, with the addition of a good part basement lighted from wide areas, and a sub-basement for heating and ventilating arrangements. Each department will be separate in its working for scholastic purposes. The accommodation provided is for 100 boarders and 100 day scholars. The building will be faced with pressed brick, with sandstone dressings, except the main entrance, which will be of Morley stone. The roofs will be covered with Westmoreland slates. The building, together with the site, will cost £28,000.

**STRANRAER, N.B.**—The new United Presbyterian Church was opened on Wednesday week. It

has been rebuilt on the site of one erected in 1840 in London-road, of the plain square box type then in vogue. The new building is designed in Late Decorated style. The walls are of dark-blue dressed whinstone, with hewn work of a cream-white stone from Prudham Quarry, Northumberland. The roofs are covered with sea-green slates, finished with red-ridge tiles, and the roof of the stair-turret is covered with dark-red tiles. The main gable faces the street, the principal entrance being in the centre by a wide double doorway, with moulded arch, and tympanum filled with sunk panelling. On each side are mullioned windows. Over the main entrance is a five-light window, the upper part filled with rich tracery; and in the upper part of the gable is a moulded niche over a carved corbel. On the western side of the main gable the gallery staircase is carried up in an octagonal tower, ending in a steep conical roof covered with red tiles. The hall and other rooms form an angle to the south and west of the church, and are similar in architectural treatment. The church is divided into nave and side aisles by stone piers and arches, the piers also carrying the galleries, which are placed behind them at the sides, and supported on steel girders. The roof construction is exposed and of dressed timber, the ceilings all wood lined, and pulpit recess is formed at south end of church with stone columns and a moulded arch over it, and the upper part has a traceried three-light window. Sittings are provided for 530 persons; the hall seats about 300, while the session house can also be opened into it when required. There are also provided ladies' room, vestry, kitchen, and heating-room, with cloakroom and lavatory accommodation. The gas-lighting is by coronæ suspended from the ceiling and brackets on the lower side walls, all designed in hammered iron and copper. The church has been fortunate in gifts of stained-glass windows. The pulpit window has been designed and executed by Messrs. Stephen Adam and Son, Glasgow; the large five-light window by Mr. Joseph Miller, Glasgow; while a four-light memorial window is from the same studio. The total cost of the church, exclusive of the gifts mentioned, will be about £4,000. The architect is Mr. John B. Wilson, A.R.I.B.A. and I.A., Glasgow, and the work has been executed under his supervision.

### CHIPS.

Dr. Charles Waldstein, Fellow of King's College, Cambridge, was re-elected on Wednesday to the Professorship of Fine Art on the Foundation of Mr. Felix Slade, for a second period of three years.

On Thursday in last week, under the direction of the Local Government Board, an inquiry was conducted by Colonel Coke, M.I.C.E., at Barnet, into an application made by the urban district council to borrow £4,102 for sewerage purposes.

The sum of £6,093 has been raised for the building fund of the west front and Victoria Porch proposed to be added to Manchester Cathedral, from the designs of Mr. Basil Champneys. Of this sum Sir William Cunliffe Brooks has contributed £2,000. This special fund is in addition to the £50,000 which was raised mainly by Sir J. W. Maclure for the restoration of the cathedral.

A public hall to seat 450 people is now in course of erection at Pitsea, Essex. The architect is Mr. Arthur T. A. Bowyer, of 90, Leadenhall-street, London, and the builder is Mr. Joseph Bayliss, of Forest Gate, E.

The Pennsylvania Railway station at Jersey City, opposite New York, was burnt on Monday morning. The buildings covered four acres, and included station buildings five stories in height, and a huge iron construction covered with a glass roof. The flames also destroyed the pier adjoining, where there was a landing-stage for four lines of ferry boats.

Mr. G. A. R. Fitzgerald and Colonel Boughey, C.S.L., Light Railway Commissioners, sitting at the Hampstead Vestry-hall, Haverstock-hill, on Saturday, concluded a three days' public inquiry into a scheme for connecting Finchley and Hendon with Hampstead by means of a light railway, otherwise an electrical tramway, along the Finchley-road, starting from Canfield-gardens, South Hampstead, near three railway stations. The scheme was opposed by the Hampstead Vestry, a committee of Hampstead residents, the London County Council, and the Finchley Urban District Council, but was supported by the Hendon Urban District Council. The engineers were Sir Douglas Fox and Mr. Wragg. The commissioners said that the necessity for the light railway had not been proved, and they therefore declined to grant an order for its construction.

## Engineering Notes.

**SCARBOROUGH.**—The new sea wall for the Marine Drive has been constructed as far south as Coffee Pot Rock, a distance of about 400 yards from the existing Royal Albert Drive, and there are already manufactured blocks for 250 additional yards. The date fixed for the completion of the contract is August, 1899, and both Mr. J. E. Everett, the resident engineer, who looks after the interests of the corporation in the matter, and also the contractors (Messrs. Cooke and Co., Battersea), are of opinion that the work will be completed by that time. £10,000 has already been paid on account of the contract (£69,270), so that, allowing for retention money, more than a sixth of the labour has been performed.

**SWANSEA DOCKS.**—The Marchioness of Worcester recently laid the memorial-stone of a dock extension at Swansea. The Prince of Wales Dock has been opened only 15 years, but three years ago it was found inadequate to meet the rapid growth of shipping in the port. Beyond carrying out extensions of other docks, it was decided to extend this particular dock so as to increase its wharfage space by 50 per cent. This addition has now been completed by Sir John Jackson, contractor, at a cost of about £70,000. The whole quay frontage on the north side of the enlarged dock has been let to the Great Western Railway Company and to the Rhondda and Swansea Bay Railway Company for the shipment of coal, the former company occupying the western, and the latter the two eastern coal tips, with frontages of 260ft. and 400ft. respectively.

### CHIPS.

The urban district council of Shanklin, I.W., have elected Mr. Ernest Charles Cooper, son of one of the members, as surveyor, at a commencing salary of £120.

The Workington Docks and Railways Bill, which involved an expenditure of half-a-million of money, has been withdrawn from the present session of Parliament.

Alterations are being made to Sedgfield Asylum, Co. Durham, embracing the ventilation, which will now be carried out on the Boyle system.

Messrs. Harry Hems and Sons, sculptors, of Exeter, have received instructions from a Guernsey Committee to prepare and erect a massive monument of grey granite. The memorial will be placed upon the rocks at Guernsey, overlooking the spot where the recent disaster to the *Channel Queen* occurred, and upon its sides will be recorded in metal letters the story of the wreck, and the names of all those who perished.

On Tuesday morning a fire broke out in a timber-yard belonging to Mr. Matthews, builder, of Nantwich. Five stacks of timber, principally pitch-pine and Californian red wood, valued at £1,500, were entirely destroyed. The fire is supposed to have been the work of an incendiary, or of some tramp, who took shelter in the timber-yard, which is isolated.

The East Sussex County Council have received a report from a committee recommending the acquisition as a site for a new county lunatic asylum of about 400 acres at the Park Farm, Amberstone, in the parish of Hellingly. The report was adopted.

The House of Lords' Committee, presided over by Lord Rookwood, resumed its inquiry on Thursday into the proposal made by the Midland Railway Company in their omnibus bill to take power for widening their line between Leeds and Bradford for a distance of 2½ miles. The clause was passed.

Colonel A. J. Hepper, D.S.O., R.E., held an inquiry at Conway on Tuesday touching an application by the town council to the Local Government Board for approval to a loan of £1,500 for the purposes of municipal buildings, and £310 for gas-works purposes.

Mr. G. S. Elliott laid on Wednesday the foundation-stone of a new infirmary for Islington at Highgate Hill, which is about to be erected at an estimated cost of £250,000. The new infirmary is to be built on the site of the Highgate Small-pox Hospital.

A London syndicate contemplates spending a large sum of money in erecting sea-defence works and developing the southern end of Cleethorpes. The scheme includes the laying-out of winter gardens, and a recreation-ground with a 50ft. front road. Terms have been offered to the landowners interested, and negotiations have been entered into between the syndicate and the Cleethorpes District Council.

### TO CORRESPONDENTS.

[We do not hold ourselves responsible for the opinions of our correspondents. All communications should be drawn up as briefly as possible, as there are many claimants upon the space allotted to correspondents.]

It is particularly requested that all drawings and all communications respecting illustrations or literary matter should be addressed to the EDITOR of the BUILDING NEWS, 332, Strand, W.C., and not to members of the staff by name. Delay is not infrequently otherwise caused. All drawings and other communications are sent at contributors' risks, and the Editor will not undertake to pay for, or be liable for, unsought contributions.

Cheques and Post-office Orders to be made payable to THE STRAND NEWSPAPER COMPANY, LIMITED.

### TERMS OF SUBSCRIPTION.

One Pound per annum (post free) on any part of the United Kingdom; for Canada, Nova Scotia, and the United States, £1 6s. 0d. (or 6dols. 80c. gold). To France or Belgium, £1 6s. 0d. (or 33fr. 30c.). To India, £1 6s. 0d. To any of the Australian Colonies or New Zealand, to the Cape, the West Indies, or Natal, £1 6s. 0d.

### ADVERTISEMENT CHARGES.

The charge for Competition and Contract Advertisements, Public Companies, and all official advertisements is 1s. per line of Eight words, the first line counting as two, the minimum charge being 6s. for four lines.

The charge for Auctions, Land Sales, and Miscellaneous and Trade Advertisements (except Situation advertisements) is 6d. per line of Eight words (the first line counting as two), the minimum charge being 4s. 6d. for 40 words. Special terms for series of more than six insertions can be ascertained on application to the Publisher.

Front-page Advertisements 2s. per line, and Paragraph Advertisements 1s. per line. No Front-page or Paragraph Advertisement inserted for less than 5s.

Advertisements for the current week must reach the office not later than 3 p.m. on Thursday. Front-page Advertisements and alterations in serial advertisements must reach the office by Tuesday morning to secure insertion.

### SITUATIONS.

The charge for advertisements for "Situations Vacant" or "Situations Wanted" is ONE SHILLING FOR TWENTY-FOUR WORDS, and Sixpence for every eight words after. All Situation Advertisements must be prepaid.

### NOTICE.

Bound copies of Vol. LXXXIII. are now ready, and should be ordered early (price Twelve Shillings each), as only a limited number are done up. A few bound volumes of Vols. XXXIX., XL., XLI., XLVI., XLIX., LI., LII., LVIII., LIX., LXI., LXII., LXIII., LXIV., LXV., LXVI., LXVII., LXVIII., LXIX., LXX., LXXI., LXXII. may still be had, price Twelve Shillings; all the other bound volumes are out of print. Most of the back numbers of former volumes are, however, to be had singly. Subscribers requiring any back numbers to complete volume just ended should order at once, as many of them soon run out of print.

RECEIVED.—R. C. and I. M.—Tangye.—D. S. R.—J. P.—J. M. and Co.—F. Bartlett.

## Intercommunication.

### QUESTIONS.

[11922.]—**Cleaning Headstones.**—Could any reader tell me the best method of cleaning headstones that have gone black? I have been told some people use an acid in cleaning; if so, could reader give me the name of the acid and how to apply it?—STONE-MASON.

### REPLIES.

[11916.]—**Dry and Wet Rot.**—There is no remedy for dry-rot; the only way to get rid of it is to cut out all the affected parts and provide ventilation, with freedom from damp, to all the woodwork. Wet rot does not spread like dry rot, and the removal of the cause of dampness which produced it will also remove the infection. It may be prevented by preparing the wood in some way by injection of creosote or other patent preparations.—LOUIS ERWOLD.

[11916.]—**Dry and Wet Rot.**—The only remedy is to cut out the affected parts, and substitute new work. Several preventive solutions have been given in the BUILDING NEWS.—H. W.

[11919.]—**Hygeian Rock Building Composition.**—The manufacturers of Hygeian Rock Composition claim that by building a wall as they advise, 9in. walls are equal in strength to 18in. walls, and, therefore, where strength is required, it would be best to put the composition into the middle of the wall about ½in. thick.—LOUIS ERWOLD.

[11919.]—**Hygeian Rock Building Composition.**—This composition can be applied to walls very easily. Let the existing wall be a 9in. or 14in. wall, which it is desired to protect from damp; build up an inner or outside casing of 4½in., after raking out the joints of the old wall, and then pour the composition in at intervals after three courses of the casing are built. Mr. White, I believe, has patented a wall lining which can be applied to any damp wall. The inside joints of wall are all raked out, and a frame is put up for fixing special-made locked tiles. As these tiles are fixed the hot composition is poured in between; when it has cooled the tiles adhere firmly to the wall, and form an impervious lining. As the tiles are rough or honeycombed on the surface, their face can be cemented or plastered. The

mode of doing this is described in a pamphlet that can be obtained of the patentee. For new walls that are being built it is necessary to allow a ½in. or ¾in. cavity between the two thicknesses. The joints should be raked out so that the composition may "key" in. It should be poured into the cavity every three or four courses. For tanks it is desirable to apply the composition between a 4½ brick inside lining erected after the main walls are built, after raking out joints. Send for particulars to Mr. W. White, Abergavenny.—G. H. G.

[11919.]—**Hygeian Rock Building Composition.**—The Hygeian Rock should be applied in between two walls in new work, but may be applied internally to existing buildings. If querist (G. Williams) will write to White, Great Western Works, Abergavenny, he will send him pamphlet giving full particulars on every point.—SURVEYOR.

[11920.]—**Hollow-Wall Ties.**—I should advise "Damp-Proof" to use wrought-iron galvanised or cast-iron wall ties, many of which are in the market. These are generally made with forked ends to give a better hold in the brick joint. Glazed stoneware ties are made by Doulton and other makers perforated, but the cavity ought to be cleared out as the work proceeds. The ties should be inserted every three or five courses in height, and be placed about 2ft. 6in. apart. The cavity should be about 2½in.—G. H. H.

[11920.]—**Hollow-Wall Ties.**—I have found that a strong galvanised wrought-iron tie is most serviceable, and that 2½in. is quite enough space to leave between the two walls. It is best to place the ties about 3ft. apart horizontally, and 9in. vertically, every other row being shifted 18in. along horizontally so as to make vertical lines of ties 18in. apart. More ties should be provided for the angles of buildings, so as to make them stronger.—LOUIS ERWOLD.

[11920.]—**Hollow-Wall Ties.**—Replying to "Damp-Proof," I advise him not to use wall-ties in hollow walls. They are most objectionable, and a lodgment of mortar upon the ties would defeat his purpose. Write to White, Great Western Works, Abergavenny, and get one of his pamphlets.—ARCHITECT.

[11921.]—**Facing Bricks.**—"L. O." may use best marl stocks, Fareham reds, or Suffolk white bricks. These bricks are to be built with a flat parallel ruled joint, or tuck-pointed afterwards. Many facing bricks are to be had of good quality. The Hartshill Brick and Tile Co., Stoke-on-Trent, or R. M. Whiting, Faversham, Kent, or T. Lawrence's hand-made facings supply excellent facing bricks.—G. H. G.

A memorandum by the Indian Government shows that 800 miles of new railway have been opened during the present financial year; 1,500 miles will be opened next year.

Extensive damage was occasioned on Tuesday morning by a fire which broke out in the timber-yard in Wenlock-street, City-road, belonging to Messrs. Eadaile and Co., sawmills proprietors. A building of two and three floors, about 100ft. by 50ft., was burnt out.

The Wandsworth Guardians, having received the necessary sanction to expend a sum not exceeding £11,400 for the purposes of a nurses' home, have decided to take steps to have the home erected at the infirmary forthwith.

Sir George Meyrick, the ground landlord of Bournemouth, has entered into a provisional agreement with a speculative syndicate to make over to them the Eastern cliffs, the narrow beach, and the foreshore. It is proposed to construct on the beach a wide drive, a footpath, and behind these to erect a row of houses about a mile long, to effect which it will be necessary to cut back the cliffs very largely, and to convert this seaside resort into a second Margate.

A new Jubilee clock has been placed in Kilham parish church tower by Messrs. Potts and Son, Leeds. Messrs. Potts are also making new clocks for Hedon, Flamborough, North Ferryby, and Whitby Abbey churches.

A terrible disaster occurred at noon on Friday at Edinburgh, the scene being the Waverley hotel building which is at present being erected by Messrs. G. and R. Cousin, of Alloa, builders, for the North British Railway Company at the corner of Princes-street. A huge scaffolding had been erected 60ft. high from the beams on the first floor, and a crane and donkey engine had been put on the top of the structure. Without any warning, the whole concern collapsed with a mighty crash into the centre of the building, carrying with it 15 workmen. Four men were killed and three others very seriously injured.

At a special meeting of the town council at Leicester on Wednesday week, the chairman of the Finance Committee announced that the Council had voted £160,000 for street improvements during the past 28 months; had devoted £230,000 more during the same time to the acquisition of parks, lunatic asylum, cemetery, and baths, and had spent £183,000 on the extension of the gas and electric-lighting plant, making an aggregate of £573,000. At the same meeting special committees were appointed to consider the expediency of acquiring the Leicester tramways and erecting a block of two-story buildings for the housing of the aged poor at rentals not involving any charge upon the rates. It was also decided to spend £6,200 on the maintenance of the Municipal Technical and Art Schools.

## PARLIAMENTARY NOTES.

**NEW GOVERNMENT OFFICES: PROPOSED EXPENDITURE OF £2,500,000.**—An important statement as to the required new Public Buildings in London was made on Thursday night in last week by Mr. Akers Douglas, First Commissioner of Works, before a Committee of the House. At present, he said, many of the Government Departments were scattered about Westminster, in houses temporarily rented for the purpose. For instance, the War Office occupied eleven separate buildings, all old and insanitary, and widely scattered, and the Board of Trade eight or nine buildings, while the Home Office and the Education Department were similarly situated. It was evident that the state of things was inconsistent with good administration. It was equally inconsistent with economy, for no less than £16,000 per annum was expended in the rent of these temporary buildings, and land of a still larger rental value was lying unused. The Government had determined to put an end to such a state of things, and they therefore proposed to introduce a Bill sanctioning the necessary expenditure for the acquisition of sites for suitable buildings, and for their erection. They asked first for a sum of £475,000 for the building of the War Office on the Carrington House site, which was amply large enough for this purpose. It contained an area of 75,000sq.ft. They further asked for a sum of £60,000 for the erection of buildings on the Parliament-street site, and another £100,000 for the completion of the purchase of that site. The scheme carried with it the widening of Parliament-street. In addition to this, they also proposed to place in the Bill the money still required for the completion of the Admiralty. As it now stood, £125,000 was wanted to complete that building according to the original plan and estimates; but owing to the very large increase of the Navy in recent years, it was necessary to provide for the corresponding increase of the staff at the Admiralty. They, therefore, asked, in addition, for £150,000 to provide for this extension. They already possessed the necessary site upon which the extension should be placed. A further sum of £300,000 was required for additional Post Office buildings. It was proposed to obtain for this accommodation the building now occupied by the Savings Bank Department in Queen Victoria-street. The building was barely large enough for the present work of that department, and was quite unequal to any expansion which would shortly be required. A fresh site for housing that Department had been obtained at West Kensington. Lastly, they asked for £800,000 for the completion of the buildings at South Kensington connected with science and art. The settlement of this question had been demanded by this House and by the public for many years past. In 1891 a decision was come to to proceed with the building to complete the accommodation for the Art Museum, and for housing the administrative Departments of Science and Art. Plans were accordingly prepared by Mr. Aston Webb, and accepted, for a building to occupy the land on the south side of the Museum, facing Cromwell-road. But the resources at the disposal of the Chancellor of the Exchequer on both sides of the House, unfortunately, did not permit of the grant of the necessary funds, and the scheme had since then been in abeyance. Since that scheme was formulated, it was in contemplation to move to the Education Office the Secretariat of the Science and Art Department; and, further, in accordance with the recommendation of the Select Committee of last year on the South Kensington Museum, it had been decided to remove the official residences and certain other temporary buildings, which were a source of danger from fire. With this additional space at disposal, it was now possible to provide on the eastern side of Exhibition-road the necessary accommodation for both Art and Science. It is, therefore, intended to build an addition to the building proposed in 1891, which would complete the frontage on both the Cromwell-road and Exhibition-road sides, and which would amply meet the requirements of both branches of Art and Science for many years to come. These items brought the total up to the large sum of £2,550,000; but there would ultimately be a very considerable set-off to this figure—of probably over a million—by the release and disposal of the War Office buildings and sites in Pall Mall and those of the Board of Trade in Whitehall. After some discussion, the resolution was adopted by 265 votes to 15.

**SOUTH KENSINGTON MUSEUM.**—Mr. Bartley asked the First Commissioner of Works on Monday whether any further plans had been made for the completion of the South Kensington Museum, and, if so, by whom; and whether he would have copies placed in the tea-room before they were finally accepted. Mr. Akers-Douglas: Mr. Aston Webb, who in 1891 prepared the plans for additions to the museum, will be instructed to draw up revised plans, and hon. members will have an opportunity of inspecting them before they are finally accepted. Lord Balcarras asked the First Commissioner of Works whether, in connection with his statement about new buildings for the South Kensington

Museum, it was to be understood that the science collections now housed on the west side of Exhibition-road were to be moved to the new buildings to be erected on the east side of Exhibition-road; whether it was also proposed to move the Indian and Oriental collections to the new galleries; and what was proposed to be done with the large extent of land upon the west side of Exhibition-road, and the buildings now occupied by the science collections? Mr. Akers-Douglas: With regard to the first and second paragraphs, the answer is in the affirmative; and with regard to the third paragraph, I can only say that it is a matter which will receive the attention of the Government when the new buildings it is proposed to erect approach completion.

## CHIPS.

About six acres of ground have been acquired by the North British Railway Company adjoining their passenger station at Possilpark, in the northern district of Glasgow, and it is intended to construct a large goods station there. The plans provide for station sidings, including goods shed and double loading bank, with offices.

A special dedicatory service was held on the 24th inst. at Garforth church, Yorks, by the Rev. Canon Hope, upon which occasion a memorial stained-glass window was unveiled. The window has been erected to the memory of Mr. A. S. R. Archer, of Garforth, by his widow, and it contains subjects of the Ascension and Resurrection of Our Lord, besides smaller pictures connected with these final events. The work is from the studio of Messrs. Powell Brothers, of Park-square, Leeds.

The Expanded Metal Co., Ltd., has just received an important order for a large quantity of expanded steel to be used in an extensive area of concrete warehouse floors in Manchester, according to one of their patented designs, a construction that constitutes an improvement upon the Monier system.

The Bill for the National Registration of Plumbers was introduced into the House of Commons by Mr. Lees Knowles, on Thursday night in last week, and was read a first time.

Sir William Fraser, formerly Deputy Keeper of the Records of Scotland, and a well-known antiquary and genealogist, who died last week, has, by his will, left to the University of Edinburgh £25,000 for the foundation of a Chair, to be called the Sir William Fraser Professorship of Ancient History and Paleography; £10,000 for the purpose of the library; and one-half of the residue of his estate, which is expected to amount to between £9,000 and £10,000, for general requirements, bursaries, research, publications, &c.

A monument to the late "Red Prince," Frederick Charles of Prussia, was unveiled on Sunday in Metz. The bronze statue of the Prince, of heroic size, stands on an octagonal pedestal more than 20ft. high.

Colonel C. H. Luard, an inspector of the Local Government Board, held a long inquiry at Osett, on Friday, concerning the application of the corporation for sanction to a loan of £4,200 for the purchase of property as a town hall site. In 1896 it was proposed to build upon another site, but the Local Government Board objected. It was elicited that the corporation was equally divided upon the purchase, which was carried by the casting vote of the mayor.

The Duke of Norfolk, on Saturday, laid the foundation-stone of the Roman Catholic Hall and Club, Westminster Bridge-road, which is to be erected and fitted as a social and recreative institute, in connection with St. George's Cathedral, Southwark. The ground floor of the building will consist of a spacious hall for the purposes of public meetings, lectures, and entertainments; the first floor will become the quarters of the men's club, and the second floor will provide a home for the juniors' club.

The new wing to the Marlborough College sanatorium, Marlborough, is being warmed and ventilated by means of Shorland's patent Manchester grates, the same being supplied by Messrs. E. H. Shorland and Brother, of Manchester.

The North Warwickshire Water Bill, an unopposed measure which has been read a second time in the Commons, came, on Friday, before Mr. J. W. Lowther, chairman of Ways and Means. Its object is to supply water to the parish of Foleshill and adjacent places in North Warwickshire, at an estimated outlay of £21,629. The preamble was proved by Mr. Joseph Quick, engineer. The Bill successfully passed through Committee, and was reported for third reading.

A stained window, given by Miss Wright, of Whitworth Park, Manchester, to Alford Church, was unveiled yesterday (Thursday) by the Bishop of Lincoln. It is in the south aisle, in what was formerly the Lady-chapel. The subject is the Annunciation. The window is by Messrs. Heaton, Butler, and Bayne.

## LEGAL INTELLIGENCE.

**THE UNSEEN WIRE AND THE ARCHITECT'S SILK HAT.**—*HUNTLY-GORDON V. THE STANDARD TIME COMPANY (LIMITED).*—In this case, heard on Friday, by Mr. Justice Stirling, in the Chancery Division the plaintiff, Mr. Herbert Huntly-Gordon, an architect, sought an injunction restraining the defendant company from fixing any wires or cables to his premises in Cheapside, and he claimed damages for an alleged trespass. Mr. Jenkins, Q.C., for the plaintiff, said the Standard Time Company's business was for synchronising clocks in London, and those of the various clock and watchmakers by means of electrical connection made with the Observatory at Greenwich. The plaintiff had acquired 60, Cheapside, and on December 18, 1896, he went on to the roof, which was very high. Without knowing anything of the presence of a wire he ran violently against one and fell. By three feet he missed a well 50ft. deep. Had he fallen into it, he might have been killed. His hat was damaged. His case was that the defendants had put up the wire without leave. Correspondence was read, in which the defendants offered the plaintiff liberty to go into any hatmaker's to make a purchase, and in this way replace his damaged property. This plaintiff refused, and he brought his action by way of protest against what he alleged to be the high-handed proceedings of the defendant company. Mr. Justice Stirling, in giving judgment, said he should assess damages for trespass merely. As the wire had been removed, there was no further need for the injunction, and the sum of two guineas, paid into court, was sufficient recompense to the plaintiff. The costs would have to be borne by the defendants up to January 22, and subsequent to that date, when the offer of compensation was made, the plaintiff would have to pay the costs.

**THE USE OF SUBWAYS.**—*LONDON COUNTY COUNCIL V. LONDON HYDRAULIC COMPANY.*—This appeal, heard on Friday, was made by the defendant company from a decision of Mr. Justice Wright and Mr. Justice Kennedy, sitting as a Divisional Court, deciding that the company were liable to pay charges at the higher scale in respect of their use of certain subways under Queen Victoria-street, Victoria Embankment, Northumberland-avenue, Shaftesbury-avenue, Charing Cross-road, Southwark-street, and Rosebery-avenue. In the action, the County Council sought to recover from the company £185 5s. in respect of their water-pipes placed in these subways. The question was whether the defendant company was a "water" company, for if it was, as the company contended, then the charge for the use of the subway would only be £32. The County Council had statutory power to fix the scale of fees and charges to be paid by any company using any of these subways, and a scale of charges was accordingly drawn up. One table consisted of the charges to be made on water and gas companies having power to break up streets, and the other of the charges for companies, bodies, and persons other than water or gas companies, with similar power. The latter was the higher scale. The company was constituted under the Wharves and Warehouses Steam Power and Hydraulic Pressure Company's Act, 1871, for applying motive power by hydraulic pressure to waterside and land cranes used for working lock-gates and other machinery; but, unlike any other water company, they were bound to return all water, after it had been used by them, to the river again. The Court dismissed the appeal, being of opinion that the Hydraulic Company was not a "water" company, and was liable, therefore, to pay as a company other than a water or gas company having power to break up streets.

**RE FRANCIS MORTON AND CO., LIMITED, IN LIQUIDATION.**—The Pearson and Knowles Coal and Iron Company's petition for the compulsory winding-up of this company came before the Vice-Chancellor of the Chancery of Lancashire last Monday morning, and on the application of the petitioning creditor it was adjourned for a week. Creditors representing an aggregate of debts of £10,633 have instructed solicitors to oppose the petition, and they will be represented on the hearing. So far, the receiver and liquidator says he has no intimation from any creditor of his intention to support the petition. There are still a number of creditors who have not intimated their views one way or the other, and we should think most of them will agree with us, that it is time the company was wound up by somebody!

**"DUROLINE" NOT WATER-TIGHT.**—In the Queen's Bench Division, on Friday, before Mr. Justice Matthew and a special jury, Mr. Arthur Firth, proprietor of a hydropathic establishment near Little Orme's Head, brought an action against the New Wire Wove Roofing Company, Limited, for damages by reason that some "Duroline" which the defendants had supplied was not equal to warranty, and not fit for the purpose for which it was supplied—the roofing of two tennis-courts. The defence was, first, a formal denial that the warranty was given, or, alternatively, that if it was given, it was true. Another defence was, that the

reason of the failure of the material was that the roof, as constructed by the plaintiff's architect, was insufficient for the purpose, as it vibrated and opened the joints. The reply to this on the part of the plaintiff was that the roof had been seen and approved by the defendants' representative before the work was entered upon. In the result the jury returned a verdict in favour of the plaintiff for £350. Judgment was given accordingly, with costs.

**BUILDERS' DUTIES AND RESPONSIBILITIES.**—**BENNETT v. CASTLE AND SON.**—In the Court of Appeal, last week, Lord Justice A. L. Smith, Lord Justice Chitty, and Lord Justice Collins gave judgment in this application by the defendants for judgment or a new trial in an action tried before Mr. Justice Lawrence and a common jury. The action was brought to recover damages for personal injuries owing to the alleged negligence of the defendants' servants. The defendants were contractors who were engaged in doing certain work at a private house from the end of September, 1896, until November 24, 1896, when the accident happened. After each day's work was over, the ladders were fastened together and laid on and at the side of the path leading to the back door of the house. The plaintiff was a baker who delivered bread at the house in question, and between 6 and 7 p.m., on November 24, 1896, the night being very dark, he walked up the path and delivered the bread, and when returning he stumbled against the ladders and fell, and was injured. The defendants' case was that, at first, the ladders were placed each night on the lawn; but the occupier of the house objected, and directed the defendants' men to place them on the path in question. The ladders were accordingly placed there, and the defendants contended that if there was any negligence at all, they were not liable. The jury were asked whether the ladders were placed there by the permission or by the order of the occupier of the house, and they answered, by the permission of the occupier, and they found a verdict for the plaintiff for £50 damages. The Court dismissed the application. Lord Justice A. L. Smith said that it was contended that the defendants' men, in putting the ladders on the path, acted as the servants of the occupier of the house, and not as the servants of the defendants. He could not agree with that contention. The answer of the jury disposed of it. The jury were asked if the ladders were placed on the path by the permission or by the orders of the occupier of the house, and they said that the ladders were placed there by the permission of the occupier. That meant that the ladders were not placed there by the orders of the occupier. That finding negated the suggestion that the defendants' men, in putting the ladders on the path, were acting as the servants of the occupier of the house. There was evidence to justify that finding, and there was no ground for disturbing the verdict. Lord Justice Chitty and Lord Justice Collins concurred.

**THE TOWER BRIDGE APPROACH.**—Mr. Under-Sheriff Burchell and a special jury heard, at Red Lion-square, last week, the case of "Williamson and Joseph (Limited) v. the London County Council," a claim for about £8,300 as compensation for the leasehold interest in premises in Coxon-place, Horselydown, and for injury to the business of electrical engineers, which the claimants carried on there. At the request of the parties the Under-Sheriff referred to arbitration the question of the value of the fixed plant, machinery, and tenants' improvements and the cost of removal and replacement of stock, stores, and loose plant. The questions left for the jury were, therefore, the improved rental value of the premises in question and the injury to the business. Among the experts who gave evidence for the claimants were Mr. Edward Stimson (Messrs. Stimson and Sons), Mr. Francis J. Bisley (Messrs. F. J. Bisley and Sons), Mr. Frederick Snee (Messrs. Bradshaw, Brown, and Co.), and Mr. Henry Shirley Price (Messrs. Wheatley, Kirk, Price, and Gouley). It was stated that the nearest suitable premises were at Highbury, and that in consequence of the great activity in the engineering trade, it would be impossible for the claimants to replace their machinery in less than three or four months. Sir William Marriott offered on behalf of the London County Council to allow the claimants to transfer the whole of their plant to the new premises. Mr. Dickens, Q.C., said that offer should have been made earlier in the proceedings; it was practically useless now. The case was adjourned till Wednesday, when the case for the County Council was opened by Sir William Marriott, who contended that £100 would amply compensate the claimants for any improved rental value which there might be in the premises for the remainder of the term, and that £250 in addition would cover any loss of business during removal from Coxon-place to Highbury. The experts who gave evidence for the Council included Mr. James F. Field (president of the Auctioneers' Institute), Mr. Adrew Young (valuer to the County Council), Mr. William Eve (Messrs. William Eve and Sons), Mr. Henry Stock, and Professor Henry Robinson (of King's College). The Under-Sheriff, in summing up, reminded the jury that the greater

part of the claim had been referred to arbitration, and that they had only to assess the value of the leasehold interest and the injury to the business. The jury awarded £350 in respect of the leasehold interest and £1,100 in respect of probable loss of trade, making a total compensation of £1,450. The Under-Sheriff stated that he had appointed Mr. E. Terry Horsey (Fuller, Horsey, Sons, and Cassell) as umpire in regard to those items of the claim which are to be referred to arbitration—namely, the value of the fixed plant, machinery, and tenants' improvements, and the cost of removal and replacement of stock, stores, and loose plant. The arbitrators will be—for the claimants, Mr. Shirley Price; and for the London County Council, Professor Henry Robinson, and the amount of their award will be added to the sum of £1,450 awarded by the jury.

**NEGLECTING TO ABATE NUISANCE.**—At the North London Police-court, before Mr. Cluer on Monday, 7th inst., Mr. W. H. Pocklington was summoned at the instance of the Islington Vestry for neglecting to abate a nuisance at No. 52, Canonbury Park South, under the Public Health Act, 1891. Considerable correspondence had passed between the vestry and the owner's architect, and a sanitary notice had been served by the vestry. Certain alleged nuisances mentioned on same had been remedied, others ignored, and the point now at issue was with respect to the sanitary condition of certain drains. The vestry's solicitor called the sanitary inspector, the superintendent of the Public Health Department, and the medical officer, Dr. A. E. Harris, to show that the drains, which all run outside the house, had been tested with a scent-test and found defective. The owner's solicitor, Mr. A. H. Hammond, called Mr. P. H. Adams, A.R.I.B.A., of 65, Leadenhall-street, E.C. to prove that he had tested the drain on three separate occasions and had found no defect. Mr. Gale, builder, of Hornsey-road, N., also gave evidence to a similar effect. Mr. O. C. Hills, A.R.I.B.A., of 147, Bow-road, E., also stated that he had tested the drains that morning and found no defect. The magistrate then adjourned the case, and announced his intention of visiting the premises on the 8th inst. and witnessing the test himself. This was accordingly done; but the test proved inconclusive, and it was arranged to again apply the test on Tuesday, the 15th inst., before the parties. This was carried out, and the magistrate could find no trace of the scent, and gave judgment for the defendant in court with £10 10s. costs.

**STEDMAN v. STEDMAN.**—In the Probate Division last week before the President, Sir F. Jeune, a petition was presented by the wife, Mrs. Helen Stedman, praying for the dissolution of her marriage with Charles Mason Stedman, an architect and surveyor, on the ground of cruelty and misconduct. There was no defence. Mrs. Helen Stedman said she was married to the respondent on April 15, 1874, at St. Barnabas' Church, Kensington, and they afterwards resided in the neighbourhoods of Clapham and Streatham. They lived happily together for some years, but eventually the respondent became addicted to drink, which habit unfortunately increased. In 1888 her father died, and she then came in for a substantial sum of money, but from that time the respondent had given up his profession, and had practically done nothing since. When the respondent was under the influence of drink he acted very cruelly towards her, and eventually hearing that she was living with another woman she gave instructions for the present suit. She had received letters from him apologising for his cruelty to her. Evidence as to cruelty and adultery having been given by other witnesses, Sir F. Jeune granted a decree nisi with costs, and he also gave the petitioner the custody of the children.

At a general meeting of the Royal Society of British Artists, held on Monday, the following were elected members:—H. P. Clifford, William Kneen, Giffard H. Lenfestey, H. Childs Pocock, H. Kerr Rooke, and Henry Stannard. Mr. Carew Martin has been appointed to the post of Keeper.

A scaffold, over 50ft. in height, in course of erection at the new school of art buildings in Renfrew-street, Glasgow, was blown down on Friday by the force of the gale. A number of workmen were on the scaffold at various heights, but all escaped with slight bruises, with the exception of a joiner, Hugh M'Turk, who was engaged near the top of the structure. M'Turk fell on his head and sustained serious injuries, necessitating his removal to the Royal Infirmary.

A new lighthouse is being built for the Trinity Board on St. Mary's Island, off Currey Point, Northumberland, and when finished in August next, the illumination of the present lighthouse at Tyne-mouth Castle (3½ miles south) will be discontinued, and the building itself removed. The new lighthouse is circular on plan, white in colour, and 120ft. in height from base to vane. It will carry a white flashing light visible for 17 miles. Mr. J. L. Miller, of Tyne-mouth, is the builder.

## WATER SUPPLY AND SANITARY MATTERS.

**ARBOATH WATER SUPPLY.**—The works for the extension of the underground water supply of Arbroath have been at a standstill for many months in consequence of a difference with the contractors, Messrs. Paterson and Son (Limited), Glasgow, as to matters in connection with the carrying out of the work. The points at issue were recently referred to Mr. Mansergh, C.E., London, as arbiter, who, instead of an award, gave a report with a view to parties coming to an amicable arrangement. On Tuesday, at a meeting of the Water Committee of the Police Commission, Mr. M'ulloch, C.E., the engineer of the works, reported that he had arranged with the contractors to proceed with the work, and that the western portion of it would at once be resumed. The brickwork of the adit is to be strengthened by being made 14in. thick instead of 9in. so far as necessary through the soil which has been disturbed.

**LONDON WATER SUPPLY.**—At Monday's sitting of the Royal Commission which is inquiring into this subject, Sir John Lubbock, M.P., was further examined. He admitted that the great majority of the water committee of the London County Council were favourable to a policy of purchase. He thought it would probably be a wise course to go far afield for a fresh supply; but it involved very intricate questions. He did not think it would be impossible for the companies to go to Wales for water. He contended that it was undesirable that an enormous work such as that involved in the administration of the water supply should devolve on the London County Council in addition to their present responsibilities. He calculated that the transfer of the undertakings of the water companies to the County Council would involve the ratepayers in a deficiency of £40,000 a year in addition to any expenditure that would be necessary for an additional supply. It was not entirely on financial grounds that he objected to the transfer of the water undertakings, as it was most important that there should be a watch kept over the purity of the water. Mr. Whitmore, M.P., the next witness, expressed the opinion that it was not in the public interest that large industrial undertakings such as those of the water companies should be owned and managed by the London County Council, so long as the Council remained a political body. The witness was still under examination when the commission adjourned.

**MANCHESTER.**—The Rivers Committee of the Manchester Corporation, at a meeting held on Friday, discussed the "biological" system of treating the sewage at Davyhulme, which was recommended by a sub-committee. The calculations of a city surveyor, who has been instructed to prepare plans for proposed new works at Davyhulme, is that an outlay of £127,000 will be required for an area of 35 acres. The Committee decided to begin experiments on an area of four acres only, and a resolution was passed asking the Mersey and Irwell Joint Committee to sanction an extension of time which will enable the Corporation to carry out the works.

## CHIPS.

The Haslingden Corporation have decided to acquire and lay out land at Rough as a cemetery at an estimated cost of £7,700, including site and chapels.

Mr. D. H. W. Powell, surveyor to the urban district council of Kingswood, near Bristol, has been appointed to a similar office under the district council for Witney.

A new organ was opened on Friday last in the parish church of Alveston. The instrument has been built by Messrs. Nicholson and Co., of Worcester.

The Duchess of Montrose will visit Cheltenham College on Friday, April 1, and unveil a statue of the Queen presented to the college chapel by Old Cheltonians.

A bronze statue of Sir William Gray, subscribed for by the inhabitants of West Hartlepool, has been placed on a pedestal facing the municipal buildings. The Earl of Darham will publicly unveil it tomorrow (Saturday).

In the case of Arthur Hollick, of Birmingham, builder, the order of discharge from bankruptcy has been suspended for two years, ending Feb. 17, 1900.

In the Dumbarton Dean of Guild Court on Monday plans were passed for an extension to the present County Buildings. The extension is to contain offices, meeting-hall, and committee-rooms, and will be built at an estimated cost of £4,000.

Major Cardew, an inspector from the Board of Trade, held an inquiry at the town-hall, Halifax, on Friday, with respect to an application from the corporation for sanction to borrow the sum of £20,000 for tramway purposes, chiefly to meet the cost of the proposed depot in Gibbet-street. Mr. Wilmshurst, the engineer, explained the proposals.

## Our Office Table.

A PARLIAMENTARY Paper has been issued this week containing reports from Her Majesty's representatives abroad as to the statutory provisions existing in foreign countries for the preservation of historical buildings. In May, 1896, Lord Salisbury addressed a Circular Note to the British Ministers abroad, stating that the Royal Society of Antiquaries of London had appointed a committee to ascertain what steps could be taken to prevent the destruction, either by demolition or restoration, of historical buildings in this country. It appeared that in France there is an "Ancient Monuments Act," under which some seventeen hundred abbeys, castles, cathedrals, and other historical buildings were said to be scheduled, and cannot be touched without the consent of the Ministère des Beaux-Arts. Similar provisions are stated to exist in Switzerland and Austria. The society were anxious to know what Statutable provisions exist in various countries with regard to this matter, and how they work. Reports have been received from all the principal capitals, and they are included in the Paper just issued.

THE report of the Fire Brigade Committee, laid before the London County Council on Tuesday, stated that the new firefloat which Messrs. Yarrow and Co. have undertaken to supply for £8,000, will be 100ft. in length, the beam 18ft., and the draught about 1ft. 7in., and it is estimated the speed will be from nine to ten knots. The fire-pumps will consist of four powerful Worthington duplex pumps, each capable of discharging 500 gallons per minute, any one or more of which pumps may be started as occasion requires, and worked at full power. These pumps will deliver into a discharge pipe connected with a water-tower in the forward part of the craft, and from which a series of branches will be carried with shut-off valves connected with any required number of fire hoses in action. On the top of this large air vessel will be mounted a water-tower ladder, the two sides of which will be formed by water pipes delivering at its topmost end and through two 2in. nozzles. The direction of these nozzles can be varied according to the instructions of the fireman at the top of the ladder by lifting, depressing, or swinging the water ladder from the deck.

A LECTURE on "The Workmen's Compensation Act, 1897," so far as it affects the employer and the insurance companies, was read on the 17th inst. before the Insurance Association of Manchester, by Mr. Charles H. Green, assistant secretary to the Sun Life Assurance Society, London. The lecturer pointed out that, by the present Act, our legislators had laid down, for the first time in this country, the doctrine that a workman in certain specified industries had a legal claim upon his trade for accidental injuries arising out of his employment, except such as were caused by his own wilful misconduct. Its provisions would come into force on the 1st of July next, when every employer would find himself saddled with new and great responsibilities, and the only advisable source of relief was offered by an indemnity from an insurance office. In order to fix a rate that should be satisfactory to all parties, it would be necessary to consider the number of workpeople killed and permanently disabled annually, the number and duration of the disablement costs, and the wages paid, and at present the data to go upon were very deficient. A committee of representatives of accident offices had been for some time past engaged in preparing a table of rates, which it was hoped would meet with the approval of all the interested parties. In the absence of direct statistics, and hampered by the indefiniteness of the compensation to be paid, their labours were not enviable; but the majority of the offices appeared to be working loyally together for the common good, and that it was hoped that a combination would be maintained which would be of incalculable value in the ultimate determination of the true rate for each particular risk, thus furthering the interests of the employers, and at the same time tending to establish the business of the companies on a sound basis.

LAST week's business at the Mart, Tokenhouse-yard, was exceptionally good, considering the nearness of Easter, the total realisations reaching £207,783, against £66,578 for the corresponding week of last year. City properties readily found buyers, the principal transactions being the sale

of a freehold with an area of 2,100ft. in Gracechurch-street at £12 per foot, and shop premises in the main Finsbury-pavement at £10 per foot. The sale of the week, so far as the provinces are concerned, was the disposal of the Golden Cock estate, Leeds, by Messrs. Hepper and Sons, for £32,600. The estate, which covers an area of 1,776 square yards, and which is let at a total rent of £850, consists of the fully-licensed inn, the Golden Cock, four shops in Kirkgate, and warehouses, cottages, workshops, and stables in Fish-street. The purchasers were the Leeds Estate Company, who have now acquired the whole of the buildings and land extending from Kirkgate to Lowerhead-row, with the exception of parts of the frontage to Briggate and Vicar-lane. The company intend making two new streets, several new arcades, and over two hundred shops. The carrying out of the whole project will involve an expenditure of half a million sterling.

THE committee on Science and Arts of the Franklin Institute, of Philadelphia, has issued a report, giving an account of some experiments, which show that cast iron undergoes, with age, a remarkable change, increasing in tensile strength, often to a very great extent, as if certain internal strains, tending to cause brittleness, were gradually relieved. It has long been known that old castings were, as a rule, superior in tenacity to new ones, and this increased strength of old cast iron has often been attributed to the better quality of the old metal; but the metallurgy of iron is so well understood now that it is not likely that any valuable secrets of mixing metal have been so recently forgotten, and it is now evident that age alone accounts for the difference. The committee of the Franklin Institute, acting on these surmises, devised a series of experiments, to ascertain not only whether time produced such effects upon cast iron, but whether they were the same with all varieties of metal, and in addition, to study the conditions under which such effects were produced or hastened. The most important discovery made in this way was that the effect of age could be produced in a short time on cast iron by vibration, or repeated shocks, such as those which small articles receive by being rolled about together in the "tumbling-barrel" used in foundries for smoothing the rough edges of small castings, and that this effect might be an increase of a hundred per cent. in the tensile strength of the piece to be tested. So far, no important practical application of the new discovery has been made, but some Pennsylvania engineers have taken the precaution, in making specifications for iron castings, to stipulate that test-bars, from which the quality of the metal is to be ascertained, shall not be subjected to shock in a tumbling-barrel, or to mechanical vibrations of any kind, before testing.

MESSRS. HAYWARD BROTHERS AND ECKSTEIN, LTD., engineers and ironfounders, of Union Ironworks, Union-street, Borough, S.E., have issued a useful section of their catalogue on their improved circular and straight iron staircases. This firm's iron staircases hold a high place in the estimation of architects. We have designs of every kind of circular and straight staircases, in which the tread, riser, and spandrel are in one, giving increased strength and stiffness over the plan of making them in three pieces. The circular ones are made in seven different sizes, from 3ft. 6in. diameter to 6ft., and for right or left hand. In specifying, it is only necessary to state height from floor to floor, diameter, and if right or left hand, or give page of catalogue, &c. A great variety of tread and riser patterns is given, from plain close ribbed pattern to open scroll design. Some are made for hardwood cubes (square trellis pattern). Any of these patterns ought to be stated. Some of the patterns have a dado screen solid and plain or open scroll patterns. The balusters and newels are also shown in a variety of effective designs, from plain fluted or twisted bars to elaborate baluster designs or openwork panels. These iron staircases are very moderate in price, ranging from 19s. per foot rise for 4ft. 6in. diameter. The straight iron staircases are shown in several pages. They are often used from drawing-room windows to the garden, for hospital wards from the convalescent balconies, and for fire escapes. The illustrations show fire-escape staircases from the Boys' Home, Marylebone, a factory at Clerkenwell, and for floors from a warehouse. Hayward's sashes made in wrought and cast iron are shown, with sections of window-bars; also casements

and frames, with sections of frames; wrought-iron doors to meet the requirements of the London Building Act for party-walls, &c.; steel-lined fireproof doors, and various kinds of ornamental wrought ironwork carried out by this firm.

THE Treasury Department of the United States has prepared a list of buildings now in process of construction for their Government, which shows that there are nineteen buildings in course of erection, but still unfinished, which were put in hand, by the order authorising their construction, before the end of 1897. It is expected that, under the new system which has just been inaugurated, the public building-work will go on at a more rapid rate than this. Besides these nineteen lingering structures, the Government has fifty-nine buildings still immature, although varying in age, the cost of which, when completed, will amount to 18,439,154dol. The largest building now under way is the Chicago Post-Office, for which four million dollars have been appropriated; but the Washington Post-Office, which is to cost a little over three million dollars, is not far behind. The Mint at Philadelphia will cost two millions. The other buildings are comparatively small structures, costing half a million or less.

### MEETINGS FOR THE ENSUING WEEK.

SATURDAY (TO-MORROW).—Edinburgh Architectural Association. Visit to Museum of Science and Art. 3 p.m.

MONDAY.—Society of Arts. "The Thermo-Chemistry of the Bessemer Process," Cantor Lecture No. 3, by Professor W. N. Hartley, F.R.S. 8 p.m.

TUESDAY.—Society of Arts. "English Art in Illuminated MSS.," by Sir E. Maunde Thompson, K.C.B. 8 p.m.

Institution of Civil Engineers. "Extraordinary Floods in Southern India," by E. W. Stoney. 8 p.m.

Auctioneers' Institute. "London Traffic Problems and their Solution," by Douglas Young, F.S.I. 8 p.m.

WEDNESDAY.—Society of Arts. "Telegraphy Across Space," by Prof. Silvanus P. Thompson, F.R.S. 8 p.m.

THURSDAY.—Society of Arts. "The Earthquake in Assam," by H. Lattman-Johnson, I.C.S. 4.30 p.m.

### THE ARCHITECTURAL ASSOCIATION.

APRIL 2nd, SPRING VISIT to new Public Baths, Pittfield-street, Shore-ditch, Messrs. Spalding and Cross and Mr. H. T. Hare, Architects. Meet at works 2.30 p.m. A visit will afterwards be paid to the adjoining Free Public Library, Mr. H. T. Hare, Architect.

Nearest route by omnibus to Shore-ditch Old Church, or by tram via Old-street, St. Luke's.

E. HOWLEY SIM } Hon. Sec.  
G. B. CARVILL }

### CHIPS.

A new water supply for Bonnybridge, near Falkirk, N.B., was formally inaugurated on Friday. The supply has been obtained from the Falkirk and Larbert Water Trustees, and the works have been carried out under the direction of Mr. W. W. Neilson, C.E.

The Lords Committee have sanctioned the proposals of the London, Brighton, and South-Coast Railway for making a fourth road into Victoria Station.

The Edinburgh Architectural Society met on Wednesday in last week, Mr. A. Lorne Campbell, the vice-president, in the chair, to hear a paper on "Church Decoration," by Mr. T. Kershaw Bonnar. Mr. Ramsay Traquair was intrusted with the criticism, which led to a discussion.

A fire which resulted in the total destruction of the Steam Joinery Works, near the Berw Bridge, Pontypridd, occurred on Friday night.

Mr. E. W. Code, of the Tiverton borough surveyor's office, has been appointed district engineer under the Ceylon Public Works Department, and has been the recipient of a testimonial from the town council.

The church of the Holy Nativity, Kowle, Bristol, has been enriched by the insertion of a stained-glass window in one of the lights of the north side, the subject treated being the Adoration of the Magi, and the presentation of their gifts of gold, frankincense, and myrrh.

The Admiralty estimated expenditure to the end of the current financial year—under the Naval Works Act of last session shows a total of £974,192, and among the largest individual items are £167,000 for inclosure and defence of Gibraltar Harbour, £145,000 for Gibraltar Dockyard extension, £185,000 and £81,000 for the dockyard extensions at Keyham and Hong Kong, and £40,000 for the Naval Cadets' College at Dartmouth.

LIST OF COMPETITIONS OPEN.

Table listing competitions with columns for project name, budget/limit, and architect/submitter. Includes entries like Godalming-Municipal Buildings (£6,000 limit) and Winchester-Public Baths.

LIST OF TENDERS OPEN.

BUILDINGS.

Large table listing tenders for various buildings across different locations. Columns include project name, contractor/submitter, and date. Includes entries like Egremont-Police Station and Courtroom, and Chester County Council.



## THE BUILDING NEWS

AND ENGINEERING JOURNAL.

VOL. LXXIV.—No. 2256.

FRIDAY, APRIL 1, 1898.

## SAFETY OF STAGING.

THE terrible crane disaster at Edinburgh we briefly mentioned last week will draw attention to the strength and rigidity of these structures in a gale of wind. It is not often we have to record accidents of this kind. The three-legged timber structures upon which cranes are put are usually well built of squared timber, and braced at certain stages, and are of not so great a height from the platform as to appear to give any ground for alarm as to their being overturned or blown down. The platform may offer some surface to the wind; but as this is horizontal, little danger from such a cause is apprehended. The ill-fated Edinburgh scaffolding was erected at the Waverley Station in connection with the new North British Railway Company's hotel at this station. The scaffolding, which was 62ft. in height, was erected on a part of the building in progress, which was then four stories high. While a large steam crane was being fitted up on the platform, and a part of it was being raised, the wooden structure, without warning, collapsed during a fierce gust of wind from the south-west. The men working on the platform were precipitated upon the building below, and three were killed and thirteen injured. The legs of the scaffold rested, we are informed, on the fifth floor of the new building, on the level of the North Bridge.

From the evidence and facts which are to hand, it would be impossible to come to any conclusion as to the exact cause of the fall. The wind, of course, exercised a very powerful overturning force, which must have strained seriously the support, or supports, on the leeward side of the structure, and we may practically say the moment of the force of the wind, which is computed to have been blowing with a velocity of 50 miles an hour, must be measured by the height of the staging—a considerable leverage. The effect of this force would be to throw the weight of the staging and crane on those supports or legs of the structure which were on the side opposite to the direction of the wind, and to intensify the pressure on them. The timber balks composing these legs of the structure would consequently be severely stressed, and any weak bracing would be taxed to a great extent. According to one witness, when the gust of wind came he saw the scaffolding bend bodily, and then there was a loud crash, and the mass came down. Another witness says, the huge staging began to "screw round" towards the east before it fell to pieces. The structure moved as one mass off the plumb, and remained virtually intact until it reached an angle of about 45°, when it collapsed. The boiler, in which steam was up, was thrown on to the top of a great block of completed masonry, above the foundation of the staging. We do not know precisely how the foundations were formed, or on what the staging rested. These may have been faulty. But we are inclined to believe that, from the height of the scaffold and the number of stages or cross braces which were used, the screwing or twisting action described was caused by a weakness in the bracing. If the evidence of this twisting can be established, it would appear to support the theory that the lateral bracing was not equal to the duty of rigidly connecting the uprights or legs throughout their height. The structure, as usually the case, consisted of three piers arranged in a triangular shape, and connected by cross-

bracing. It was built of stout timberwork, and rested on iron beams laid on the walls, and it is stated that the supports were raised on the top of the piers which had supported the earlier crane scaffold. The bases were firmly secured, it is stated, by means of chains, and on the platform ten tons of material had been laid down, so as to counterbalance the weight of the steam crane of like weight, and which had a lifting power of three tons. The jib at the time of the catastrophe was projecting outwards, and a man was engaged at the time in fastening the tie-rod which was to raise the beam. There was, therefore, a considerable top-load on the platform, including crane, boiler, and counterweight, and this might have had some effect in producing the twisting motion, and thereby in dislocating the braces and causing collapse. A correspondent sends us a sketch of the structure, from which we gather that the framed timbers were bolted together. It would have added much to the safety of the structure exposed to gales if it had been supported by oblique guys firmly anchored to the ground or buildings. The scantlings of the timber might have been sufficient for the greatest stress put upon them if these had been rigidly connected by the cross-braces. In the mean time, we await the inquiry with interest.

## SOCIETY OF BRITISH ARTISTS.

A GREAT deal in this exhibition we may pass over as of little originality or merit. In the central gallery half a dozen large canvases occupy important positions, their merits being less apparent. Tom Robertson's large, hazy landscape painted in a grey key of colour, "The Valley of the Tay" (4), has a breadth and atmosphere that recommend it to the attention, and near it is a full-length portrait of a lady seated, rather flatly painted in the face, in a delicate heliotrope walking costume, that is not devoid of those qualities of character painting and harmony so often missed, by S. H. Sime. At the same end of gallery is a picturesque coast view well known to tourists of the north-eastern coast, "Robin Hood's Bay," by W. E. Tindal (10), and two or three other works by the same hand show a poetic realisation of landscape. But on this wall the most charmingly painted of the seascapes is Terrick Williams' "Morning: Whitby." Mr. Williams has scarcely done anything better than this fleet of trawlers and fishing boats seen through a misty sunlight. The sun is piercing through a hazy atmosphere, and subtle gradation of colour and reflection appear, and we have, in fact, a delicate symphony of silver grey. "Evening Glow, Brixham" (150), and "A Summer Sea" (194) are other studies of light and atmosphere worthy of Clara Montalba. Fresh colour and skilful handling are seen in Alfred S. Edwards's Scotch coast scene, "Home from the Fishing" (21), a large wave is seen breaking as it tumbles in to the shore; Robert Morley is another felicitous painter; "The Falling Tide" (49) and his "Highlanders," a dog group (303), are excellent studies in their respective subjects. A few small pictures are hung over the fireplace. "Pets" (52), by T. Watt Café, is well composed. Two Italian girls under a portico, one feeding pigeons and the other holding a vase, are refined in drawing and brilliant in the colour. Arthur Meade's "Across the Common" (71) is a large landscape. The evening effect is happily rendered, and Montague Smyth has chosen a similar theme, a flock of sheep being led through a country road—a pleasing study of waning light. Painted with true sympathy is A. E. Borthwick's "Little Match Girl" (77)—a poor wan-faced child sitting in a dark recess, with a flickering light in her hand,

offering her wares. A large landscape, "Herald of Spring" (85), by Frank Spenslove-Spenlove, deserves notice. The white blossom of the trees and landscape are handled with much freedom, and the management of the white masses of the bloom is successful. A spring landscape is not the easiest to paint, owing to the delicacy of the tints. Two clever figure subjects by J. Sanderson Wells relieve the tameness of this part of the exhibition. "Gaslight Study" (87), a lady seated, in a pale canary satin, is decidedly one of the best works of the kind; and his "Gleaning" (110) is a delightful piece of outdoor realism. The two stooping gleaners are drawn with simple grace, and there is a happy arrangement of line and colour in the sloping, golden-hued stubble-field, and the grouping of the figures, that reminds us of the work of that painter of French peasant life, Clausen. A restful evening effect is E. Borough Johnson's "At Close of Day" (104), in which the figure of a labourer carrying a scythe is appropriate. A clever, broadly-treated face is Mr. Graham Robertson's "The Jade Necklet" (101). At one corner of the room is a pleasing portrait study of two young girls, daughters of S. Lamas Dore, J.P. (121); the colour is delicate, and the chrysanthemum background pretty. The painter is G. Hillyard Swinstead, a promising painter in this branch of art. Of course, we have a few of the "pot-boiler" class, like "Teasing Rover," very large. The composition "Children of the Foam" (149), that occupies the centre place on the long wall, is decorative and allegorical. It represents two sea-nymphs on a rock in a rough, foamy sea feeding and caressing a flock of seagulls which hover round. The painter, A. D. McCormick, has conceived a design of originality and power, French in motive and colour; but the tone is cold, and the flesh tints marble-like. Two other large canvases may be mentioned—Greville Morris's landscape "The Fold" (135), a moonlight effect, and H. P. Hain Friswell's view "Dolgarrog, North Wales" (159). The hazy atmosphere is well realised. Magnitude counts for a good deal with some landscapists. Montague Smyth's "Eventide" is also a clever piece of reflected light and shadow, and the work of Haynes King, "Cinderella in Rustic Life" (140), of Wm. Strutt's "The First Sight of the Cross" (168), and of Robert Morley's "Ready" (174), are of interest, especially the last.

In the south-east gallery Hal Hurst has a portrait of Mrs. C. Thompson (181) seated, in a delicate white evening dress, and a little further J. W. T. Manuel—"Mlle. Laval-lière"—shows a stylish full-length figure of a Parisian lady in a dull red walking costume, trimmed with grey fur. The high collar obscures the lower part of the face—very aggravating if it is not intended to be a caricature. The President, Sir Wyke Bayliss, sends two fine interiors in his wonted style, in which all the glory of marble and stained glass and sculpture is manifested: "Louvain Cathedral" (208) is a splendid piece of draughtsmanship and colour. In the next gallery, his interior of Milan Cathedral we have seen before. Here the painter has full scope for his imagery and poetic fervour, and this pseudo-Gothic fane in all its splendour of sculptured pillars and colour is fully realised. C. E. Ritchie's study, "Black and White," a full-length portrait of a lady in black reading, on a white ground, relieved by delicate sprays and birds, has a French-Japanese motive.

R. Ponsoby Staple's "Leather Hunting" is a large, commonplace view of a cricket-field during a match. Arthur Briscoe, in "Rest" (260) has a pleasing study of a reposing girl in an orchard, graceful and vigorous, and there is freshness and atmosphere in Robert Goodman's large picture, "Drear October" (289), and in Percy R. Croft's "Along the Quay." Beyond these there is little to notice.

Chimney Bond

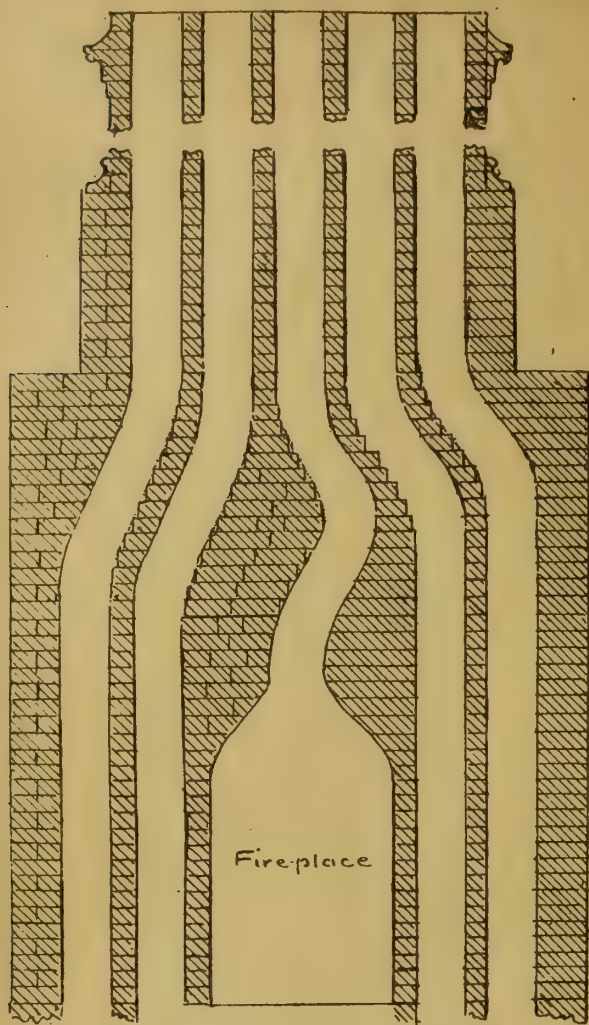

Section of Flues

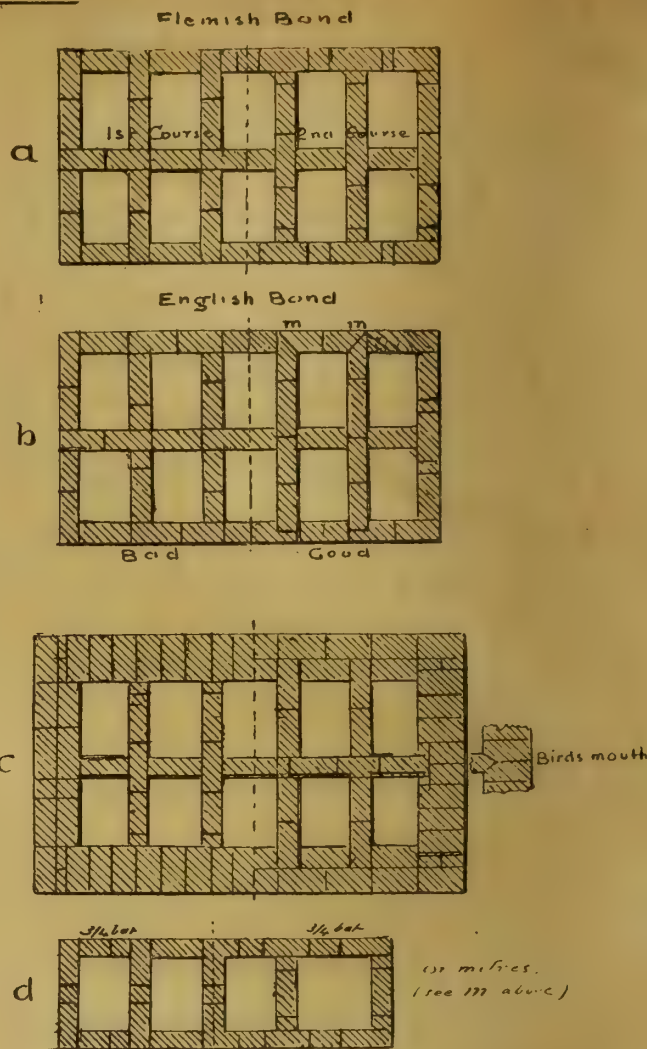

Plans of Shafts

Several clever drawings and sketches in water-colour are to be seen in the North-West and N.E. Galleries. Leopold Rivers' work is always good; his "Moonlight," with its gleaming river (313), is pleasing. James Tower's "Calm Evening" (312) and Robert Horner's solid work (318) may be mentioned, also "Eventide," by F. Spenlove-Spenlove (323). Dora Woodhouse sends a nice drawing of the "Interior of St. Bartholomew's" (328), and Miss Clara Taylor another view. Minnie Brown has a broadly-treated figure subject, "Evening"—a girl carrying a bundle of wood—admirable as a study of real life and landscape; and Geo. C. Haité has a bright study of "Farmlands" (354), and a brilliant sketch of a "Market Place" (357), both broadly handled. Two drawings, picturesquely treated, are sent by W. Harding Smith, "The Cobb Gate, Lyme Regis" (333) and "The Council Chamber in the Rath-Haus, Goslar" (403), showing some Late Gothic panel-work. Percy Dixon has a powerful picture, "Among the Tumbled Fragments of the Hills" (356). A clever piece of impressionism after Melville is Hans Hansen's "Scarboro' Regatta Day," a view of a throng of sightseers on the Pavilion. Cecil Aldin's "An Elopement," a pair tearing away in galloping speed in a carriage and four over a rough tract of country covered with snow, is vigorous. The drawing and movement of the belaboured horses are clever; and there are a few nice sketches on the screen by W. Tatton Winter (470), Janet Boothroyd (476), R. Ponsonby Staples (482), Harry P. Clifford (483), Harry Goodwin (49), John M. Bromley (507), H. Sylvester Stannard (518), and two symbolical subjects by

R. Machell rather too ambitious. The chalk drawings in the vestibule by J. W. T. Manuel, O. Eckhardt, and Sidney H. Sime are clever from a comic or music-hall point of view. We have here the realism of the stage and the music-hall. The work of Sidney H. Sime is often vivacious, as that of Manuel is eccentric. Many of the sketches are burlesques. "The Unacceptable Sacrifice" (544), "A Foul," "Nude" (549), "Pianoforte Recital," "Au Café" (554), "A Shadowy Dance," "Sloane Street," "A Wicked World," "At the Casino," "Chanteuse Eccentrique" (593), "Confetti et Serpentina," are clever but eccentric.

MODEL SPECIFICATIONS.—VI.

BRICKWORK—(continued).

THE construction of chimneys is an important branch of the bricklayer's craft, though it is often inadequately described. It is needless to say the footings should be formed of a sufficient number of courses, and be built upon a bed of concrete, so as to distribute the weight of the breasts. When the building is of several stories, the weight of the chimney-breasts and stacks are considerable, and would tend to subside or drag down the wall if a good spreading foundation was not provided. The "throat" of chimney, or the lower end of the flue, should be small and well "gathered over," each brick projecting about 1½ in. beyond the course below, and the narrowest part of throat should be over the centre of fireplace. Flues are generally made 9 in. by 14 in., though for small grates 9 in. square is suffi-

cient. For kitchens of large houses, a flue 14 in. square is usually built. In our section we show the arrangement of the flues of an ordinary town house, five flues being shown. Care is necessary in avoiding any sharp angle; but the flue should change its direction. A straight flue would be always smoking, and letting the rain and snow down. We show this necessary bend by the curved centre flue, which is supposed to be from the fireplace in the top story. The London Building Act (section 64) states: "Chimneys and flues having proper soot-doors of not less than 40sq.in. may be constructed at any angle; but in no other case shall any flue be inclined at a less angle than 45° to the horizon, and every angle shall be properly rounded." This is an important rule, and should be mentioned in the specification. The "withes" of chimney should be carefully executed, and be air-tight to prevent one flue destroying the draught of the adjacent one. It is impossible to make good bond; the use of bats cannot be avoided. But the specification should insist that they are to be well built, of well burnt bricks and the joints broken, and the withes should be well plastered or pargetted with a superior mortar.

Pasley, an authority on brickwork, recommends the bonds of chimneys to be executed with cement or with the best description of mortar mixed with tile dust, that "withes" should be plastered with it instead of common "pargetting" of lime and cow's dung. Coal ashes in the mortar are recommended. Fireplaces should be proportioned or built with reference to the bond or to the size of grate. In apartments

Damp Proof Walls

Fig 1

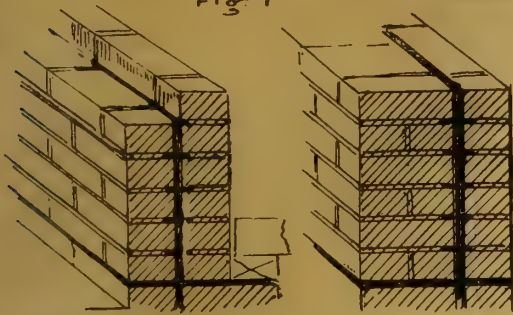

Shewing White's "Hygeian Rock"  
Building Composition

Fig 2

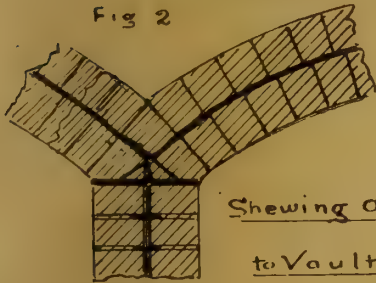

Shewing Application  
to Vault or Tank

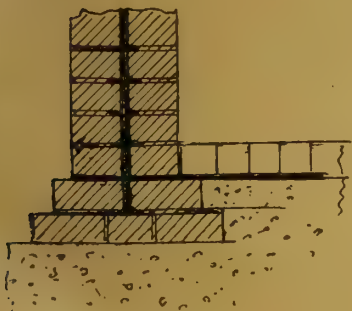
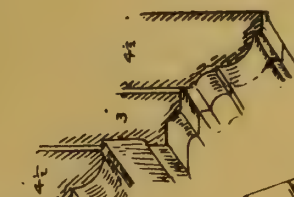

Fig 3



Moulded Bricks



Brick  
Cornice

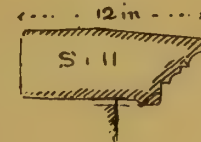

Sill

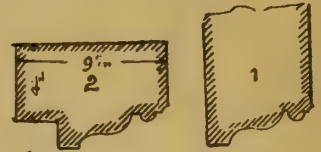
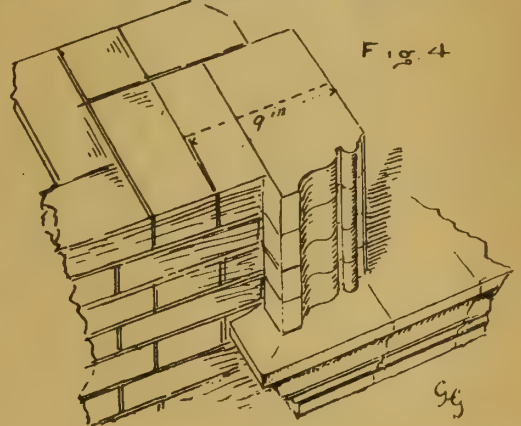

Fig 4



Brick Architrave

the fireplace may be four bricks or 3ft. wide, the jambs one and a half brick deep; in height the same, 3ft., not less. The depth is never less than 13½ in. or one and a half brick, nor greater than two bricks. We show different kinds of chimneys in plans a, b, c, and d, in English and Flemish bond, and where the "closers" and half-headers come. In the bond (see b) mitred bricks as at m m may be used, or the bricks between flues let into the stretchers as shown. One brick external wall ought to be used as shown at c. In the single shaft plan d the 14in. square flue takes the kitchen fireplace.

On a previous page (369) we gave a few sections of hollow walls. We now supplement them by the method already noticed of building two brick casings with 1in. or ¾ in. cavity, into which is run a specially-prepared liquid composition (White's "Hygeian Rock" building composition), which can be poured into the cavity as the work proceeds, every three or four courses. The sections show a 9in. and a 14in. brick wall, with the composition filling up the cavity, extending from the damp-course, and also entering into the joints on each side, which are raked out as the wall is carried up (as shown in Fig. 1). The same vertical damp-lining forms also a valuable fitch-like plate increasing the rigidity of the wall, dispensing with the need of iron ties, and adding considerably, as we can testify by experiments at Islington some years ago, to the strength of a 9in. wall. Two half-brick casings, with the cavity filled in, was supported like a beam upon supports, illustrating the great adhesive strength of the "Hygeian Rock" composition. In Fig. 2 we show how a series of vaults or a storage tank may be protected by a horizontal layer beneath the brick floor on concrete, and the

vertical lining taken round the arch between the two rings of brickwork.

33. *Chimneys and Flues.*—Turn rough brick segmental arches over all chimney openings; properly contract openings, and form throats to flues. Properly bond the withes of flues, and parget and core the same. Build the chimney-stacks in cement mortar as shown in drawings, with weathered capping and courses. Or—

The chimneys to be built as shown on plan and elevations. Carry up a separate flue to each fireplace, with easy bends. Gather the throats over openings quickly, and form the pockets as shown. No flue to be inclined at a less angle than 45° to the horizon, and the angles to be well rounded. Parget the flues with cow-dung mortar composed of 1 part cow-dung to 4 parts of hair mortar, and properly core. The flues to be 14in. by 9in. (or 9in. by 9in.) All flues at a less angle than 45° to have soot-doors and frames for sweeping. Or—

Carry up separate flues to the fireplaces with easy bends, and parget and core the same. Gather the throats over openings as shown. All flues inclined at a less angle than 45° with the horizon to have soot-doors for cleaning, and well round all bends. The external brickwork round the stack of flues to be 9in. thick. The "withes" are to be built with care, bonded to outer walls or to break joint (or the flues, instead of being pargetted, to be lined with fireclay flue-pipes of cylindrical or oblong shape, 9in. or 12in. in diameter), of Doulton's manufacture.

34. *Shafts.*—Build the shafts above roof in English or Flemish bond in cement mortar, as shown in drawings, finished with a neat weather joint. The tops to be finished with projecting courses (or with cornice-moulded bricks), and provide and fix to each flue a terracotta pot p.c.—bedded and flanchued round in cement. Cement fillet to be run round top of sailing course. The plinth to have moulded bricks as shown set in cement above the given work.

When the chimney-stacks diminish externally, insert a clause to describe this, or, preferably, give a detail. At the various offsets the bricks are "tumbled in," or terra-

cotta or stone blocks are inserted, weathered or moulded. Sometimes the shafts are enriched by panels, or by arches and pilasters in brick, in which case mention the particular moulded brick, if square or angular in section. Ornamental pilasters should be shown in detail or sketch, and show the bond. We shall give sketches next week.

The London Building Act provides certain rules as to chimneys (Sec. 64), in addition to the rule as to the angle of flues we have mentioned. The section states: "Chimneys built on corbels of brick, stone, or other incombustible materials, may be erected if the work so corbelled out do not project from the wall more than the thickness of the wall (measured immediately below the corbel); but all other chimneys shall be built on solid foundations, and with footings similar to the footings of the wall against which they are built, unless they are carried upon iron girders with direct bearings upon party, external, or cross walls, to the satisfaction of the district surveyor." Another sub-clause provides that an arch of brick or a bar of wrought iron of sufficient strength shall be built over the opening of every chimney to support the breast, and if the latter projects more than 4in. from the face of wall, and the jambs be of less width than 17½ in., the abutments shall be tied in by an iron bar or bars of sufficient strength turned up and down at the ends, and built into the jambs at least 8½ in. on each side. Other sub-clauses state: The flues of oven furnaces, cackle steamboiler, or close fire used for trade, or for cooking apparatus of any hotel, &c., are to have brickwork at least 8½ in. thick. The inside of every flue, and also the outside, when passing through any floor or roof, or near any woodwork, is to be rendered,

argeted, or the flue lined, with fire-resisting stoneware-piping. The jambs of every fireplace opening are to be at least 8½ in. wide on each side, and the breast of every chimney, and the brickwork of every smoke-flue, shall be at least 4 in. in thickness. The back of every fireplace in a party-wall, from hearth to 12 in. above the mantel, is to be at least 8½ in. thick, and the thickness of the upper side of every flue at an angle of less than 45° is to be at least 8½ in. It is also provided that the highest six courses of every chimney-stack shall be built in cement. Several other sub-clauses relating to building shafts, and their height above roof flat or gutter, cutting into chimney-breasts, timber and woodwork near flues and chimney openings, are given in this section. One of them states that the brickwork of any shaft is not to be built higher above the flat, or roof, or gutter than six times the least width of shaft.

#### ORNAMENTAL BRICKWORK.

The clauses we have already given are those which may be used in specifications of plain buildings; but the architect is often required to specify for particular kinds of brickwork of a more architectural character, ornamental gables, dormers, chimney-stacks, bay windows, cupolas, and window and door dressings, &c., come under this head. In other instances, terracotta or stone in their various forms are combined with the brickwork. Half-timber work, brick and flint, and other varieties of building are also to be considered, and it will be necessary to give a few clauses of a general kind that will apply to these descriptions of work.

We give now a few patterns of the moulded bricks usually made, and the manner the jambs or reveals of windows and doorways are worked. It will be seen that these bricks admit of a variety of combinations for cornices, string-courses, architraves, jambs, &c., which the architect may select and specify, and these arrangements ought to be sketched in the margin. We show a sketch of an architrave for a window, Fig. 4, and the two special bricks required to form the bond; also for a brick cornice and window-sill. Other sketches of ornamental brickwork, to illustrate cases which occur in practice, we shall give in our next article.

A general clause ought to appear providing that any moulded bricks or gauged work are to be made or executed from the architect's designs, and the bricks trimmed or touched up before burning. Moulded bricks should be made a trifle thicker than common bricks, to allow for rubbing and the finishing of joints. Before the scaffolding is struck, the work ought to be rubbed or rasped, and the arrises made straight and true.

1. *External Facings.*—The external walls to be faced with approved picked bright stock facing bricks (or Suffolk white, or red Fareham) carried up with a flat ruled joint in washed sand and lime or slightly coloured (or tuck-pointed in fine stuff). No headers to be broken. Or—

Face the walls and chimney-stacks with the best red facing bricks (or Lawrence's, or picked stock facing bricks, or pressed facings) laid in English (or Flemish) bond finished with a neatly-struck weather joint as the work proceeds. The moulded brick courses to be all headers, to match the facing bricks in cement, and rake out joints and point to match the facings. All arches to be of the best rubbers, rubbed and gauged and set in cement. Or—

Face the external walls and the other ornamental portions shown on elevation with approved selected Suffolk (or red Fareham or bright stock) bricks, and point the work as it proceeds with a weather-joint in washed sand and lime or slightly coloured with ochre. Or—

Rake out joints and tuck-point in fine stuff when striking scaffold (or with blue ash-mortar and flat joint). All chimney-stacks should be pointed with a weather-joint in cement, after raking out the mortar joints.

2. *Dressings.*—All window and door dressings, plinths, eaves, and other courses to be formed as shown in detail with red Fareham (or washed malms or moulded bricks). Or—

The pilasters, window and door reveals, and quoins to be executed as shown in detail, with

cut and rubbed red-brick or other approved rubbers set in fine putty (or with moulded bricks as shown). Or—

All string-courses, sills, jamb mouldings, cornices, and other projecting members to be executed, as shown, in red Fareham (or other approved) rubbers in fine putty, the weathered courses being in cement.

#### THE SOCIETY OF ARCHITECTS.

THE fifth monthly meeting of the Society of Architects was held at St. James's Hall, Piccadilly, W., on Thursday evening in last week, the president, Mr. T. Walter L. Emden, J.P., L.C.C., in the chair.

#### OWNERS OF PROPERTY AND RIGHTS TO LIGHT.

Mr. A. A. HUDSON, A.S.I., Barrister at Law, read the following short paper on this subject, entitled: "The Position of Owners of Property with Regard to Rights of Light and Other Easements, with a Suggestion for Future Legislation." He proposed, he said, to deal with the subject, as far as possible, from a layman's point of view, and to avoid legal terms. The question to be faced, continued the lecturer, is whether anything can be done to remedy the existing state of law, and obviate the great difficulties which are placed in the way of, or I might say added to, building operations, by the tactics of persons claiming rights of light. Those tactics are known, I am sure, to everyone in this room, and therefore it would serve no purpose to enlarge on them. Of course, there are two sides to every question, and the person whose light is to be affected has a right to protection. Now, in order to consider the possibility and advisability of legislation, it is as well to consider analogous legislation in the case of party-walls. Before the London Building Act, and previous Acts dealing with party-walls, there was constant litigation. The owner of the property upon which buildings were proposed to be erected, or rather reconstructed, often did not know whether the dividing wall was a party-wall; and even if he knew that, he did not know what kind of party-wall it was. A party-wall may mean, first, a wall of which the two adjoining owners are tenants in common; secondly, the term may be used to signify a wall divided longitudinally into two strips, one belonging to each of the neighbouring owners; and, thirdly, the term may designate a wall divided longitudinally into two moieties, each moiety being subject to a cross easement in favour of the owner of the other moiety. In case of a longitudinal division between two neighbours, each of them could pass away one moiety; and if this was done, the moiety of the other owner might be of little use to him. Many other peculiarities and difficulties arose—more useful to the lawyer than to anyone else. All this doubt has been disposed of by the London Building Act, which constitutes every division wall a party structure with certain definite rights, and in case of any dispute the parties can refer to the arbitration of a technical tribunal. The objection raised to legislation in matters of this kind always is that private rights should not be taken away by Act of Parliament, unless there is a very strong case for so doing. Undoubtedly the London Building Act does take away private rights, but so do many other Acts. The Lands Clauses Acts compel a person to sell his property or his rights in it, and legislation of this kind is permitted because in the public interest it would have been disastrous to prevent great public enterprises being carried out either at all, or at such great expense, by paying out blackmailers, as to render the enterprise a failure. In the case of party-walls, the rights as between private owners have been legislated for, and this offers a stronger case of legislation than in the case of great public enterprises like railways, canals, and so on, where legislation has been, so to speak, between private owners and the general public. It must be remembered also that in the case of party-walls under the London Building Act, nothing in the Act authorises any interference with an easement of light or other easements, and this would include a right to support. But the powers conferred by the Act of dealing with party-walls in all kinds of ways are so wide, that this reservation interferes but slightly with the useful operation of the Act. The person building must so deal with the party-wall that the adjoining owner's easements are not interfered with; but directly either a building or adjoining owner proceeds in any way to use the powers of the Act, he brings himself under its

powers and loses the rights which he had at common law. The question is, in what way building in London could be simplified as regards rights of light by some such legislation as the London Building Act in relation to party-walls. I think the first principle to be adopted is that disputes should be settled by a technical tribunal, and I think that the tribunal should be presided over or be assisted by a lawyer. The reason I suggest that a lawyer should be added is because the rights of neighbouring owners are much more complicated than in the case of party-walls. The reason for a technical tribunal is obvious: instead of the disputants having to prepare elaborate models, and to call in conflicting evidence of the facts, the parties would come before a tribunal composed of persons who understood plans, and who could, and should, view the site and surrounding buildings. In the next place, the persons proposing to build should serve notice on the adjoining owners, and the meaning of the term "adjoining owners" would have to be defined so as to include occupants, trustees, reversioners, tenants, and all persons who might claim right of light. The notice, I think, should specify exactly what kind of building is proposed to be erected, and that the plans, sections, and elevations can be seen at the offices of the tribunal to be created to dispose of such cases. The parties on whom such notices are served should be called upon within a certain time to specify their objections (if any) to the proposed building. The building owner would then know the persons from whom he must expect opposition and claims. It would be difficult to take away an adjoining owner's rights to compensation for injury to light upon a failure to answer such a notice, and it would not even be possible, I think, to settle the amount of compensation to be paid in any case before the buildings were erected. But the object to be attained would be to get settled at once by a competent tribunal, whether upon the plans deposited the building owner should or should not be restrained by injunction; and I would suggest that no person who had been served with the notice, and had failed to object at the time to the proposed building, should be entitled subsequently to apply to have the building pulled down. If on the application of objecting parties an injunction was granted by the Court, of course, the building owner would have to make fresh plans; if no injunction was granted, then he would be free to build; but, on completion, he would be obliged to meet any claims made against him for injury to light or air. The distinction between an injury which will entitle an adjoining owner to an injunction, and an injury which would only entitle him to damages, has been more or less defined by many judicial decisions; but the principle of those decisions might be codified so as to strengthen and direct the tribunal, who in the first case have to decide whether an injunction should be granted or not. This tribunal should, I think, be able to decide this preliminary question without a jury; but when the building was erected, unless the partners had in the meantime agreed, I think a claimant should be entitled to a jury if he wished it, the tribunal, of course, being the same. I do not think it necessary that the tribunal should only have to deal with matters of right to light. There are a great many disputes about building, engineering, and other technical matters which may well be disposed of by a similar court. One of the most important matters in view of legislation is to provide some remedy for the enormous costs which a litigant may be put to now without any means of preventing it. There are, as most of you know, two scales of costs, one between party and party, and these are all a successful plaintiff or defendant can recover; and another scale called solicitor and client costs, and it is the difference between these two which a successful defendant or plaintiff has to pay. In the cases in which expert evidence, models, and so on are required, this difference is very great. Eminent judges have already expressed an adverse opinion on these two scales of costs, but in the case of a technical tribunal being created to settle and dispose of the matters I have indicated, the tribunal should have power to regulate the scales of costs as well as the procedure, subject to the approval of the Lord Chancellor. This was so provided in the case of the Tribunal of Appeal under the London Building Act. I think this tribunal affords an illustration of the advantage to litigants of having their cases disposed of by men with a practical knowledge of the

subject. I do not say this because I am a member of that tribunal, but because persons have found out how promptly their claims are disposed and how short the trial is, this being due partly to the fact that the tribunal always views the site or buildings as the case may be. With a similar tribunal light and air cases might, I think, be disposed of equally well. I have now concluded my subject. I have purposely made it suggestive. The suggestions are simple, and I have stated the points for consideration shortly, so that in the discussion which I hope may issue the experience of members will bring into more prominence those matters which are of importance to surveyors and building owners.

Mr. G. GARD PYE, in proposing a vote of thanks to Mr. Hudson, said information of great value to architects had been given, especially to those practising in London, where questions of light and air often arose. With regard to party-walls, he did not quite follow the author's definition of a party-wall, and stated a case in which he could not be quite certain whether the structure could be reckoned as a party-wall or not. He proposed the following resolution:—"That a Parliamentary Committee be appointed to inquire into the present state of the law with regard to ancient lights and other easements, with a view of saving the large amount of moneys now expended in determining and settling the rights of owners with regard to the same."

Mr. J. R. MANNING seconded the vote of thanks, remarking that the question of ancient lights had for a long time been one most difficult to decide, men's ideas as to the value of light being so various. Such a tribunal of qualified men as that suggested by Mr. Hudson to deal with questions of light and air would be of the greatest service to the profession. As an example of the various values set on light, he mentioned the cases of two dentists. One of these, by the erection of an adjoining building, had the light of his operating room a good deal affected, but did not, however, take any action. In the other case, the second dentist raised a question about a shadow which was cast across his operating-room, and declared that he could not stay in the building any longer. His case was put into the hands of lawyers, and after a long trial it was decided in his favour, and 14in. had to be cut off the offending chimney by which the shadow was cast. The whole question of ancient lights was beset with difficulties, and he could not help remarking the almost fabulous value which some owners put upon their windows. He also wished to second the resolution proposed by Mr. Gard Pye, as well as the vote of thanks.

Mr. GEORGE HUBBARD said there was one point in Mr. Hudson's paper which he did not quite understand. The lecturer had proposed that the tribunal should adjudicate upon the amount of compensation to be paid for loss of light after the building was erected. In the case of the speculative builder this would be very hard, as, after his building was erected, it was most likely that the speculative builder would have no money to meet any liabilities which might be claimed as compensation. He considered that the builder should know what claims he would have to settle before the building was erected.

Professor BANISTER FLETCHER, in supporting the vote of thanks, said he had known and admired the lecturer for many years; but he thought a man could admire another, and yet not agree with him. He should like to point out the immense difference between party-walls and light-and-air questions, so that they might appreciate the distinction between the two. The case as mentioned by Mr. Hudson with regard to the London Building Act of 1894 was extremely good; but there was obviously a vast difference between party-walls and light and air. In the case of a party-wall, it was important that both sides should have it dealt with in the easiest and speediest manner possible; no right was lost by rapidly dealing with a party-wall, which should be rebuilt in the speediest manner possible. But in the case of light and air, the man who wished to build wanted to deprive a man of that which had been his from time immemorial, and which belonged to him as much as the house he occupied. The case of the two dentists which Mr. Manning had given them was rather amusing, and it appeared to him that Mr. Manning had either "done" one man, or that he had given way too much to the other. Referring to the value of windows, he alluded to a lecture given recently by Dr. Longstaffe, in which it was stated that the Hotel Windsor had rendered unfit

for habitation some model dwellings of the artisan class by taking away their sunlight. He thought there was usually a great objection on the part of the architect against anyone stopping his building. He had been in the profession a great number of years and could, therefore, appreciate this great difficulty of the architect; but they ought to keep a judicial mind, and to remember that there was always the other side to be thought of. They must consider, too, how far the proposed tribunal would meet the difficulties. The London Building Act had certain intentions, and everybody thought the Act carried out these intentions; but it did not do so. Indeed, the lawyers regarded it as one of the worst-drawn-out measures existing in the Statute Book. Ground-rents had now advanced to such an enormous extent in value that in London every inch of space was valuable. There was no doubt, as Mr. Hudson had said, that the cost of litigations in questions of light and air was enormous; but it was not an unmitigated evil, for it made men timid of entering into such cases. He was aware of a large hotel, the proprietors of which had put aside a sum of £20,000 to fight any light-and-air cases which might be brought against them. The Court of Chancery was, in his opinion, a highly respected tribunal, with which he was very well satisfied, and he doubted whether they could constitute another tribunal, in which the public would feel an equal degree of confidence. He differed from Mr. Hudson's suggestion that rights of light could be simplified in London by some such provision as that which existed in regard to party-walls, because the two things were entirely dissimilar. Professor Robert Kerr once made a similar proposition, but it ended without result, and he believed any like suggestion to-day was also doomed to be inoperative. In his opinion, the Society of Architects was doing a great deal of good by ventilating such important subjects as those before it.

Mr. HENRY LOVEGROVE said that the whole question was thoroughly gone into some years ago by a committee appointed by the Institute of Architects, and a careful report was drawn up; but it was found impossible to proceed with it, because there were so many lawyers in the House of Commons. He agreed with Mr. Hudson's views, and thought that with such a tribunal as suggested all would work very well, and would be a great improvement on the cumbersome system now in vogue. He was glad to hear Professor Fletcher say a word about the speculative builder. The speculative builder was a much-abused man, but he did not know what they would do without him.

Mr. ELLIS MARSLAND, hon. secretary, thought that Mr. Hudson had foreshadowed some very welcome changes in the building laws of London, to gain which architects and surveyors, as well as lawyers, must be prepared to make some sacrifice. Mr. Hudson had pointed out that he wanted all questions dealing with light and air to go before a technical tribunal, because he wished to avoid expense and delay. These same questions of light and air were also matters in which architects and surveyors often got into bad repute. In the cases which came before the Courts in the usual way, they would have three or four surveyors on the one side swearing that there was a great amount of damage, and they would have three or four surveyors on the opposite side swearing that there was no damage at all. Such instances as these gave the judges a very bad impression of their profession. Mr. Hudson's idea was that the members of the tribunal should go down to the site and inspect it for themselves, and they would then be able to form an opinion without taking conflicting technical evidence at all.

In closing the discussion, the PRESIDENT observed that, in his judgment, there was not such a vast difference between party-wall cases and cases of light and air as had been assumed by Mr. Fletcher, and he considered that Mr. Hudson's proposal was a good one. He had had some thirty years' experience in the architectural profession, and during that period he had necessarily had something to do with questions of light and air. He had noticed that where a public building was erected more claims for compensation were put forward than in the case of a private building. According to Mr. Hudson's proposal, the person about to build would first serve a notice on the adjoining owners, and if any of them thought they possessed a claim, they should within a certain period give notice of such claims to the tribunal.

The tribunal would then settle whether or which of the adjoining owners' claims were legal and the amount of compensation to be awarded. Under the present system he had often known builders to be stopped for eighteen months or two years at a time, because some adjoining owner had brought an action for right of light against the building owner. This delay was often a serious matter, whereas by Mr. Hudson's proposal the matter was settled at once. Many people who had no legitimate right of light often put in claims, and these claims were generally a source of great expense and trouble. Mr. Hudson's proposal was a commonsense one, and should, therefore, appeal to everybody.

The vote of thanks and the resolution were then put and carried unanimously.

Mr. HUDSON, in reply, said that Mr. Marsland had hit the right nail on the head. What he had suggested in his paper was that they should have a technical tribunal, but they might have more than one lawyer upon it, or a judge if they wished. In any case, the tribunal should have power to visit the site, and so avoid wasting time. In this way the adjoining owner, whom Professor Banister Fletcher wished to protect, would be protected by a cheaper tribunal. Professor Fletcher had said that the speaker was wrong in dealing with questions of light and air in the same way as party-wall cases were dealt with. He thought, however, that the two cases were very similar, as a party-wall might deprive an owner of his rights, just as much as a builder might deprive an adjoining owner of his rights of light; and it was of equal advantage that questions of light and air should be dealt with as speedily as possible. Professor Fletcher had said that there was no tribunal which had power to take away a man's rights except the Court of Chancery; but he would point out that the Lands Clauses Consolidation Act, though not a tribunal but a Statute of Parliament, did deprive a man of his rights. It had power to compel a man to give his land, if public enterprise demanded it, and awarded him a reasonable amount of compensation, and he thought it was right in every case that the minority should give way to the majority. Replying to Mr. Hubbard, he would point out that it would be very difficult to judge the amount of damage to a man's right of light until after the building was erected, and it was impossible to fix the amount of compensation till the damage had been determined. He agreed that it would be hard in the case of the speculative builder; but he did not see how it could be avoided. Every person had a right to build on his own land; but when his building interfered with the right of light of the adjoining owners they had a perfect right to compensation. He had read a paper on this subject at the Surveyors' Institution, and he noticed that the members looked rather blue at the idea of his tribunal, for they thought that the whole of the work of surveyors would be wiped out. What he proposed doing was, he thought magnanimous, as he would be wiping out an immense amount of litigation. He was rather disappointed that the discussion had followed the lines it had. He thought there would have been no question as to the necessity for his proposal, but that speakers would have made suggestions for its efficient carrying-out. It was certainly a great advantage for a man to go before such a tribunal and be told that either he had or had not a right of light. In any case, if they would cheapen the trial of light-and-air cases, they were conferring a benefit on both sides. What he had suggested was, that there was an opening for a new system of legislation—for a system of simplified legislation, and he left the matter, together with his proposal, in their hands.

#### THE ARCHITECTURAL ASSOCIATION.

THE fortnightly meeting of the Architectural Association was held at 9, Conduit-street, W., on Friday evening, the President, Mr. Hampden W. Pratt, F.R.I.B.A., in the chair. Messrs. C. C. King and S. J. B. Stanton were elected as members. It was announced by the PRESIDENT that a demonstration on stained glass would be given before the members by Mr. Christopher Whale on Monday, April 4th, at the Central School of Arts and Crafts, Regent-street, W. Mr. E. HOWLEY SIM, hon. secretary, stated that the annual Members' Soirée will take place at the Café Monico, Piccadilly, on Friday, April 29th. A vote of thanks was passed to

Mr. T. W. Dinwiddy for permitting the visit on the previous Saturday to the public baths in New Cross-road.

#### CONSTRUCTIONAL STEELWORK.

A paper on this subject, illustrated by numerous diagrams, was read by Mr. T. CUNNINGTON, who observed that until recent years this topic was considered to be within the sphere of the civil engineer only; but with the developments both in character and in extent of recent buildings and requirements, it has to be seriously considered by the architect. In buildings of the warehouse or factory class, the construction is comparatively simple. The complication, both as regards loads and construction, arises where the several parts of the same building are occupied by several different classes of tenants and devoted to different uses. In city buildings, where space and light are of the most paramount importance, every thought and care has to be taken with the view to limiting the columns, stanchions, girders, and floors to the minimum sections consistent with their carrying power. In the first place we will consider

#### INTERIOR COLUMNS AND STANCHIONS

with their several connections and joints, as upon them depends principally the stability of the superstructure. Interior columns and stanchions form one of the most important steps in the modern problem of design, and greater variations are probably to be found in them than in any other features of steel construction. Each of the several forms has its own adherents, and the many types of connections between the columns and stanchions, and with the floor systems, permit of an unlimited choice. We will endeavour to investigate the more prominent forms, and point out the advantages and disadvantages of each. The most satisfactory for general and specific cases may then be selected as combining the desired features. The relative advantages of the various sections are of the greatest importance, as affecting economical and successful design. In actual practice the treatment of the different shapes will be found to vary greatly with the designer, not only in the relative value of the sections, but in the treatment of any one section. In the first place, the formulae differ greatly—not in fundamental principles perhaps, but in the treatment being often empirical, and containing factors deduced from some special case. These formulae, also, generally assume ideal loading, which seldom occurs in the actual building, and none, or very few, full-sized tests have ever been made on the effects of eccentric loading. The general principles which govern the

#### RESISTANCE OF BUILT COLUMNS

may be summed up as follows:—(1) The material should be disposed as far as possible from the neutral axis of the cross-section, thereby increasing resistance. (2) There should be no initial internal stress. (3) The individual portions of the column or stanchion should be mutually supporting, and (4) the individual portions of the column or stanchion should be so firmly secured to each other that no relative motion can take place, or they will fail as a whole. From experiments, we know a closed column or stanchion is stronger than any open one, due to the fact that the edges of the segments are mutually supporting when held in contact by complete closure. Therefore the circular-built column is undoubtedly the most favourable form for compression, because the capacity of columns of equal areas varies as the metal is removed from the neutral axis. It must also be remembered that any form of column or stanchion, having a maximum and minimum radius of gyration, is not economical for use under a single concentric load, as the calculations must be based on the minimum radius of gyration. The metal represented by the excess of the maximum radius of gyration is, of necessity, disregarded, and part of the section is thus lost or wasted when we consider the ideal efficiency of the column; but practice does not always support theory, and many other questions besides mere form arise in connection with the judicious choice of a section. The form of stanchions and columns most generally in use are No. 1 section, made of four angles, riveted back to back; No. 2, of two T-bars, also riveted back to back. The caps and bases of these are easily formed by either forging one of the flanges of each bar at right-angles to the stem, or riveting forged angle-seatings to the stem to receive cap- and base-plates. These stanchions are frequently made up of angle-bars

and plates riveted together as indicated. The strength and size can be either increased or decreased as circumstances require. The caps, bases, and flange-plates of these forms are attached by angle cleats riveted to the plates, angles, and webs. Bearings for joints or girders at intermediate levels can be readily riveted either to the web or flanges of them. Another type is made up of four angle-bars, with strap-bars, say, every 4ft., or diagonal bracing suitable to the purpose, to be used either as stanchion or bracing. Other stanchions are made up of single joists, joists and angles, joists, tees, and plates, and joists with one riveted both sides of web. The strength of each of the sections can be adjusted either by increasing the size of the joists, or angles and tees, or by the addition of flange plates. The cap- and base-plates are attached to the shaft by riveting angle-cleats to the webs and flanges to form the requisite bearing surface for the flange-plates. Stanchions are often made up of channel sections and joists, or of channels, bars, tees, and plates. These forms of stanchions are applicable for continuing through two or more stories of the building admitting of two or four girder joists bearing at the same level. Other sections, again, are made up of flanged quadrant bars, flanged quadrant bars and channels; the diameter can be increased and decreased as occasion requires by using smaller or larger sections of channels. Certain of these sections, whilst retaining the minimum diameter, can be very considerably increased in strength by adding plain or bulb-shaped tees, plain bulb-shaped angles, or by the addition of plates, either inside or outside of the channel bars. Another form is made up of channels and Lindsay's special angles, or plain angles. This particular section was very successfully used in the West Australian Bank, Cornhill. Stanchions formed of channels and angles readily adapt themselves to purposes of construction of high buildings, where several floors have to be considered, and supported by the same stanchion. The section can easily be made to suit any number of loads and floors, by either increasing or decreasing the diameter, or increasing or decreasing the sectional area. These sections have found particular favour with the American architects and engineers in the construction of their high buildings, from the fact of their easy adaptability to their specific requirements, to their form and construction, and from the fact that they can be readily incased with fire-resisting materials independently of being made up of bars, that are either kept in stock at the mills or can be generally quickly supplied. Drawn steel columns are made from 4in. up to 24in. in diameter, and from  $\frac{1}{2}$ in. to 1 $\frac{1}{2}$ in. metal in one piece, excepting the flanges forming caps and bases. They are made in lengths not exceeding 21ft. or 22ft., and are generally used in lengths not exceeding in height one high or two short stories; when they are superimposed, the single joist girders bear upon the flanges, and are attached. When columns of larger diameter are required, and girders either of double joist compound girders or riveted plate girders are used, the columns are made to seat on the girders, the girders abutting and being continuous, the flanges of the caps and bases being bolted to the girders. Ornamental caps and bases, either in cast iron or other metal, can be readily adapted to these drawn steel columns, to suit the several styles of architecture. The great advantage of these columns is that you get the greatest amount of carrying power for the minimum diameter and thickness of metal; this deserves consideration when space is an object, or where shipment has to be considered. One of these columns was tested at Messrs. Kirkcaldy's with most excellent results, the length being 14ft., 7in. diameter, and 1in. metal, the calculated safe load being 92 tons. It was tested up to 180 tons, practically without any movement, and no injury was observable under microscopical examination. Other forms of columns are built up of steel plates and the bars, and curved steel plates for large diameter columns, heavy constructions; or, where they are exposed, their form admits of being increased almost to any diameter and strength. The cap and base flange-plates are attached by angles riveted to shaft, and the flange-plates riveted to the angles. In special cases an additional plate is put on, the outside extending from 12in. to 14in. from the ends before putting the flanges on for purposes of additional strength. The steel stanchions shown on Wm. Lindsay and Co.'s sheets combine the principle of the ordinary angle-bar stanchion and the column, the bars being rolled in such

a manner as to form a hollow shaft, and placing the metal at as great a distance from the central axis as possible. They are made of four bars, or, for additional strength or diameter, plates or bulb-bars are inserted between the flanges of the angles. The cap- and base-flanges are attached to forged bent plates, or angles riveted to shaft. These stanchions have been extensively used, as, independently of their strength, comparatively with their diameter and sectional area, independently of the fact of being easily incased in fire-resisting material, either rectangular or circular shape, to suit the architecture of the building. Taking a stanchion 14ft. long, 8in. diameter, the safe load is 80 tons, and generally, in practice, the full load has been placed upon them, and proved satisfactory. To increase the size of the bases and bearing-surface area of the various steel columns and stanchions referred to, to provide for heavy or extreme loads, they rest upon cast-iron bases, formed to suit each special requirement. The cast bases may either rest upon joist foundations, hereafter referred to, or upon adequate stone bases and concrete foundations, the columns and stanchion bases being bolted down to the cast-iron bases.

#### THE FIREPROOFING OF COLUMNS AND STANCHIONS.

As columns and stanchions carry the greatest concentrated loads found in modern buildings, the proper fireproofing of these becomes a most important subject for consideration; unfortunately, in only too many cases is this slighted or omitted, even to a very dangerous extent, as has been proved in numbers of instances. Many systems have been introduced, and both the "hard tile," the "porous tile," "terracotta," and concrete have been used extensively. The requirements in the adequate fireproofing of columns and stanchions are:—1. The material must be indestructible by fire. 2. The material must not be heat-conducting. 3. The material must be so secured to the columns or stanchions that it cannot be dislodged. The use of hard fireclay tiles is only to be recommended when such tiles are hollow with a sufficient and proper air-space around the metal column or stanchion, and even then experience seems to show that the hard tile is in no way so satisfactory under great heat as the porous kinds. Application of cold water in combination with heat have also proved the hard tile far less reliable in case of conflagration than the porous tile, as the hard tile is very apt to crack off under such conditions. The use of solid blocks of porous tile well bedded against the metal column or stanchion or solid pumice concrete, seems to be the most highly satisfactory. The requirements for fireproofing the interior columns and stanchions by the Chicago Ordinance are defined as follows:—(1) "The coverings for columns or stanchions shall be, if in brick, 8in. thick; if of hollow tile, one covering at least 2 $\frac{1}{2}$ in. thick. If the fireproofing is made of porous terracotta, it shall be at least 2in. thick, whether hollow tile or porous terracotta is used; the courses shall be so anchored and bonded together as to form an independent and stable structure." (2) "In all cases there shall be on the outside of the tiles a covering of plaster with Portland cement, or of other solid cement of equal hardness and efficiency when set." (3) "If plastering on metallic laths be used as fireproofing, it shall be in two layers, of which the first shall be applied in such a manner that the concrete or plaster will cover the entire external face of the column or stanchion, while the space between the two layers shall not be less than 1in. The metallic laths shall in each case be fastened to the metallic frings and the plastering upon same shall be made with cement."

#### FOUNDATIONS FOR COLUMNS AND STANCHIONS.

In designing the foundations for columns and stanchions for a building, where they rest upon a yielding stratum, proper provision must be made for the uniform distribution of the weight. In cases where the loads vary, the foundations should be proportioned according to the different loads, so that the bearing per unit of ground area will be equal, and a uniform settlement of the structure assured. Where the loads are excessive an excellent foundation for columns and stanchions can be formed with rolled steel joists, either in a single bed or more, the foundation for them being prepared by a suitable bed of Portland cement concrete of ordinary depth, then placing the joists thereon. Where unusual loads are to be supported, the joists may be crossed in two

or more directions, each at right angles, their distances apart from centre to centre varying from 9in. to 24in., according to circumstances—i.e., length of their projection beyond the masonry, thickness of concrete, estimated pressure per square foot, &c. They, however, should be placed at least far enough apart to permit the introduction of concrete filling between the joists. The most useful application of this system of foundation is on sites where a thin and comparatively compact stratum overlies another of a more yielding nature. By using joists in such cases, the requisite spread at the base may be obtained without penetrating the firm upper stratum or carrying the footing courses down to an unusual depth. In covering the joists with concrete, 6in. should be left at the ends and sides of them, and 1½in. to 2in. on top. A convenient way of doing this is to make a plank frame of the same size as the concrete bed, and at the proper height and perfectly level; after this is filled it is made for the next courses, and so on, the whole exterior rendered with Portland cement, so that no metal is exposed.

THE METHOD OF CALCULATION FOR JOISTS

used in foundations may be stated thus:—The arms or projections of the two lower courses are fixed by the lengths of the upper ones, and by the dimensions of the subsoil area; hence, the question is, how many joists are required?

Let  $y$  = projecting arm of any course.

$a$  = width of supporting area.

$l$  = total load on footing.

$M$  = bending moment on one side of plate.

Then the length of joist =  $a + y + y = a + 2y$ .

Load on  $y = \frac{l y}{a + 2y}$  and since the distribution of the load on every layer is uniform, we have—

$$M = \frac{l y}{a + 2y} \times \text{lever arm } \frac{y}{2} = \frac{l y^2}{2(a + 2y)}$$

In calculating the lower course,  $y$  becomes a known quantity and  $M$  an unknown. The usual spacing where three tiers are used is 15in. for lower tier, 12in. for middle tier, 9in. for top tier. For any other spacing of pressure than given,  $M$  can be found from the formula—

$$M = P \sqrt{\frac{sb}{12}}$$

When  $P$  = the projections in feet for the several tiers of beams.

$b$  = the allowable bearing capacity per square foot of ground in tons.

$s$  = spacing in inches.

The method in regard to the calculation of such footings is still an unsettled question, as some engineers claim that the action of the concrete filling, with its tendency to bind the iron and concrete together, causes the foundation to act as a whole, and thus possess a moment of resistance much greater than the sum of resistance of the individual layers. But in view of the uncertainty of such assumption, the method of calculating all moments about the edge of the casting would seem more logical, as well as being on the safe side. In determining the sizes of the joists in any layer, care must be taken to leave sufficient clearance between the flanges to admit the concrete, which must be rammed in place. Hitherto this class of foundation has been but little used in this country, although it has been used in several isolated cases. In Messrs. Jones and Higgins's warehouse, Peckham, it was very successfully used. A modification of the system lends itself readily as foundation for columns, stanchions, and piers for buildings or corner sites, or where the side of the building is of such a nature as necessitates the system being used. It has been used in the construction of the new premises in the Strand, at the corner of Adam-street. In this instance the joists are framed 3in. or 4in. wide, and rest upon the solid concrete foundation, substituting the usual piers and footings for the front walls. Another instance is in the building of some flats at Tufnell Park. In this case it was not considered advisable, from the nature of the site and the great expense, to take the walls down to the requisite depth for foundation. Piers about 4ft. square in Portland cement concrete were taken down to the solid strata, and upon these piers a framework of steel joists was built, properly fitted and connected together to carry the external and principal internal walls. By this method, it will be inferred, there is little or no possibility of any one part of the wall subsiding without affecting the general structure. The foundations, basement columns, &c., are either surrounded by constant moisture or by the wet

clay or earth itself. For such positions cement mortar should undoubtedly be used, as, from experience, it seems the most perfect conservator of metal work. A further recommendation of the use of cement lies in the fact that the thermic expansion of Portland cement is practically the same as that of steel—a fact which insures perfect cohesion under any changes of temperature. It has been suggested to rely entirely upon the preserving qualities of cement rather than upon a proper painting of the metal work. Professor Bauschinger states that his experiments show a cohesion between steel and concrete after hardening of from 570lb. to 640lb. per square inch, which is more than the tensile strength of good concrete; but in building work a perfect union between the cement mortar and metal work can never be attained at all points, and a thorough coat of paint must be largely relied upon. All constructive steelwork should therefore be well coated with either lampblack mixed with oil, or red lead and linseed-oil, the very best of materials being employed. The oxide of iron or mineral paint which has generally been specified for all painting of the metal-work has been found to separate from the steel and form an oxidation of the metal behind the paint. A mixture of red-lead and linseed-oil is now considered as the best protective coating for iron or steel. Having regard to their importance in steel construction, we have dealt somewhat in detail with columns and stanchions, together with their foundations. We will now proceed to deal with girders, their connections, and bearings, and the various forms of floors.

GIRDERS.

In designing a building numerous cases occur where a single joist-girder will not be suitable, and it may be necessary to increase the length of the spans, so as to reduce the number of the supporting columns or stanchions to the minimum, or perhaps heavy, concentrated loads, such as columns, stanchions, brick walls, chimney-breasts, and stacks, necessitate the introduction of plate and angle-riveted girders, or compound girders of joists and plates. Having calculated the loads on the several girders, it is an easy matter to determine the sections most suitable to the purpose. It frequently happens in designing a building that excessive loads are concentrated at two or more points of the floor, and in order to confine the construction within the limits of the design without increasing the sections where the minimum loads occur, recourse has to be had to various methods. The depth of the girder being reduced to the minimum in order to obtain the required strength, the flanges of the girders must be unusually wide, the webs well stiffened or trussed. An illustration of this occurs in ground floor ceiling of the West Australian Bank, Cornhill, as also the ceiling of the news-room of the Shore-ditch Library. Where the ends of the girders rest upon the wall, it is advisable to use steel bearing-plates or joists to distribute the pressure over a greater surface, and thereby prevent the crushing of the material in the wall directly under the girder. In most cases a large tough stone will be sufficient; but where the pressure is heavy, both plates and stone should be used. The average pressure per square foot for brickwork should not exceed 6 tons, and for stone 12 to 20 tons, according to its character. In calculating for loads upon girders where the bricks are laid regularly that the probable line of rupture (providing the girder should fail) will be found to be inside of the sides of an isosceles triangle, whose base is the span, and whose height is one-third of the span; in order to be entirely upon the safe side, the weight of the wall between vertical lines directly over the girder for a height equal to that of the triangle is frequently adopted as the load to be carried. However, it should be noted that for green walls, or walls having openings, this rule does not apply, as the full height of the wall between the points of support must be provided for. Where the width of the walls, either internal or external, exceeds 14in. that are supported by girders, it is advisable to use compound girders or plate girders; and where plate girders, it is preferable to have them double-webbed, or box girders, the latter giving greater stability than the single-web girder. In all built girders it is advisable that the flanges alone are to be considered as resisting the bending moments, and both flanges nominally of the same section. No angles used smaller than 2½in. by 2½in. by ½in., and no webs of less thickness than ¼in. Stiffeners

of tee or angle-bars must be used where the depth of the girder is above a certain ratio in proportion to the web (say, 70 times), and disposed so as to resist the shearing forces upon the web. In all cases it is absolutely necessary that they are provided at all bearings, and at points of concentrated loadings, and where straight stiffeners are used (they being preferable in girders for building work) the ends of them both top and bottom must fit closely against the flange angles in order to fulfil their proper functions. The safe loads for steel joists are given in the various merchants' catalogues, as also for compound girders made of joists and plates. In designing compound girders—say, of two joists, with plate top and bottom, take the safe load given for the two joists, making due allowance for the quantity of material taken from the flanges in the rivet-holes, and the difference must be provided for in the sectional area of the plates. The distinct functions of the flanges and webs of all girders with thin, continuous webs are that the whole of the horizontal strains must be provided for in the flanges, the web practically taking no part in resisting them, neither are the horizontal flanges considered to take part in resisting the shearing forces, the whole of which must be provided for in the webs. In selecting joists for girders or similar purposes, the proportion of depth to length should not be less than one-twentieth of the span, otherwise deflection may take place. Due allowance must be made for all holes drilled in the joists for connections, &c., more especially for such that are placed in the flanges. The depth of plate girders should be one-tenth to one-sixteenth of the span; the greatest economy of material is perhaps obtained at one-twelfth. For continuous girders or girders fixed at the ends, the depth may vary from one-fifteenth to one-twentieth of the span. The width of the flange not less than one-thirtieth to one-fortieth of the span, and no plates should be less than ½in. thick. The general formula for plate girders of this class is—

$$S = \frac{W I}{8 D}$$

$S$  = strain on top and bottom flange at centre in tons.

$W$  = weight distributed in tons.

$L$  = length of girder (or span in feet).

$D$  = effective depth of girder in feet.

Steel may be strained to 7 tons per square inch in tension and compression, although some authorities limit it to 6 tons per square inch.

FLOORS.

Before considering the most economical arrangement of steelwork for floors, the question of loads, which very largely governs the design of the floor system, must be examined. The loads in building construction may be classified as dead, live, and eccentric loads, the principal loads affecting the floor systems are:—

*Dead loads*, comprising all of the static loads due to the constructive parts of a building, stationary machinery, water tanks, or other permanent loads.

*Live loads*, comprising the people in the building, office furniture, movable stocks of goods, or varying loads of any character.

The maximum live-load per square foot is usually assumed as follows:—

For Crowd of people .....	80lb.
„ Floors of house .....	40 „
„ Theatres and churches .....	80 „
„ Ballrooms or drill-halls .....	90 „
„ Warehouses, &c. ....	from 250 „ up.
„ Factories .....	200 to 450 „

While 80lb. is the maximum possible live load per square foot from a crowd of people (unless dancing be considered.) Still, we can hardly expect to realise any such load under the conditions governing an office building. Large crowds very seldom collect in offices, except on the lower floors devoted to stores or banking purposes, and greater allowances are generally made for such places; the ordinary office furniture will certainly not exceed and seldom equal the weight allowed for persons, and hence additional security is introduced. These loads used in the calculations affecting the girders, columns, and stanchions must not be confounded with the required loads for the strength of the individual floors, while the live load per foot super. may be reduced over large areas in proportioning the girders and columns. The maximum possible live load must still be used when any single floor is considered by itself. The practice in America seems to be pretty well defined in the matter of decrease of

live loads per square foot, as they are transferred from beams to girders, from girders to columns, or stanchions, and thence down the columns to the footings. This practice is founded upon the supposition that it is quite possible that the beams may sometimes have to carry their full capacity in live loads, while the chances are increasingly less that the girders or columns will ever be required to carry anywhere near their full capacity if a full load had been assumed. The fully-loaded area would probably never be large, and a girder or column would rarely, if ever, lie in the centre of such area. The effect of a live or moving load, causing vibration in the parts of a structure, is also gradually lessened, as the vibration, if any, is taken up in the transfer of the load from member to member, so that by the time it reaches the footings, or foundations, the live load is ignored entirely. As examples of this system of calculation the following may be mentioned. In the Venetian Building in Chicago, the beams were calculated for the following live loads:—

Upper floors, per foot super. ....	35lb.
Second, third, and fourth floors, ditto ..	60 "
First floor, ditto .....	80 "

Girders carry 80 per cent. columns 50 per cent. of the loads. The weight of the steel girders, and brick or tile partitions are actually calculated for a typical floor plan, and then rated at so much per square foot of floor surface. The dead loads assumed in the old Colony Building, Chicago, comprised:—

Flooring .....	5	lb.
Deadening .....	18	"
Tile arches .....	35	"
Iron .....	10	"
Plaster .....	5	"
Partitions .....	18	"
Total .....	90lb.	per foot super.

giving the following results:—

	Beams.	Girders.	Columns.	Footings.
Live loads .....	70	50	40	90
Dead loads .....	90	90	90	90
Total .....	160lb.	140lb.	130lb.	90lb.

In the administrative block of the Royal Infirmary, Liverpool, which is five floors high, a similar system of calculation was adopted in regard to the strength for the lower columns and girders. In floors generally, one of the main points to be considered is that they must be firm and rigid, and at the same time as light as possible and subject to no vibration. To insure this desideratum, the joists must be of adequate depth. Where floor framing abuts on girders, it is seated on angles which are riveted or bolted to the webs, and in special cases the joists are angle-cleated to the girders.

#### STEEL FLOORING.

There are several systems of steel flooring, each having some special features and more suitable for particular purposes:—No. 1 is flooring made of steel trough-bars of various sections and weights per foot, from 4½in. deep to 12in. deep; the depth of the 12in. section can be increased to 15½in. deep by the addition of bars. The sections up to 12in. deep are riveted together on the neutral axis, and the sections over 12in. deep require two rows of rivets. This steel flooring is used in the floors of the National Liberal Club, Prudential Building, Holborn, and in the Bishopsgate Goods Depot. Section No. 2 (Messrs. Wm. Lindsay and Co.) is rolled in depths 10in., 12in., 14in., and 18in. if required. In this section it will be observed the riveting is on the top and bottom flange. Section No. 3 is either rolled or pressed in several depths and strengths, and is used as in No. 4, with plain bar riveted to both top and bottom, the edges of the troughs abutting. It is also used as No. 5, with the troughs lapping and one row of rivets top and bottom. Section No. 6 is a simple form of flooring, composed of plain plates and angles riveted and connected. It can be made any strength, depth, or span by increasing the sectional area of the plates and angles, or by increased depth. It is nominally the same price per ton as the other section. Where the ends bear upon the walls, steel or iron bearing-plates must be provided, and it is advisable to keep these plates a little distance in from the face of the brickwork. These several classes of flooring can be fixed either upon the top or bottom flange of the girders, or upon angle-bars that are riveted upon the webs of the girders, and bolted down. These floors are well adapted for warehouses, factories, mansions, and public buildings, or in any situation

where great and variable strains occur, either by crowds or the vibration of heavy machinery. The strength of these steel floorings when riveted together is considerable, as each trough may be treated as a girder. As the whole is riveted together, no one portion can deflect without dragging down the adjoining troughs for some distance from the point of application of the weight. At this stage it would not be advisable to go into the question of the finishing of the floors, as we consider it ought to be treated separately, or dealt with in a special paper. In order to render a building "fireproof" where steel construction is used, it is absolutely necessary that every member of the construction must be thoroughly and adequately incased in some fire-resisting material, so as to remove the metal from the direct action of the fire; and if this particular is insisted upon, we shall not have such lamentable catastrophes that continually occur, more particularly in city buildings.

At the conclusion of the paper a hearty vote of thanks was accorded Mr. Cunningham on the motion of Mr. B. FLIGHT FLETCHER, seconded by Mr. C. H. BRODIE, and supported by Messrs. R. MORLAND, GIFFORD READ, and MARK FAWCETT.

### SANITARY WORK.—III.

#### SINKS.

In its elementary form a sink may be defined as a basin or trough designed to receive dirty and waste waters. Sinks are, however, largely used for washing-up purposes in connection with the varied operations of domestic life. As a consequence, slop or waste waters are formed, each of which may be totally distinct in character, so



Fig. 27.

that it is not only convenient, but even necessary, that they should be dealt with separately. A type of sink must, therefore, be selected, which shall be suitable for each particular case.

For ordinary household requirements sinks may be divided into five classes—viz., (1) Scullery and kitchen sinks, (2) butlers' pantry sinks, (3) housemaids' washing-up sinks, (4) housemaids' slop sinks or closets, (5) laundry sinks or troughs. They are usually made of glazed stoneware, fire-clay, earthenware, slate, galvanised or enamelled iron, and wood lined with copper and lead. Formerly, stone sinks were largely used; but are now practically obsolete. They were most difficult to keep clean, as the stone was found to absorb grease and other impurities, with the result that, after a time, they became most offensive.

For permanent sanitary efficiency it is essential that the materials composing the sink should be non-absorbent, not easily acted upon by acids or



Fig. 28.

alkalies, and having a perfectly smooth surface. The internal angles should be rounded, every part of the fitment being exposed to view, and easily accessible for cleaning purposes. The special requirements of each class of sink in general use will now be considered in detail.

#### SCULLERY AND KITCHEN SINKS.

These are principally intended to receive the various greasy and dirty liquids which ordinarily arise from culinary operations: they are continually subject to much rough usage, and must, therefore, be thoroughly strong, and impervious to moisture. White glazed fireclay and salt-glazed stoneware provide a very satisfactory fitment for this purpose. They should be free from fire-cracks or flaws of every description.

Enamelled iron sinks—commonly known as

"jaw-boxes"—are also largely used in some parts of the country. They are impermeable and easily cleansed, but are liable to damage from rust and chipping of the enamel. In small houses, where no other sink is provided for kitchen use, all the greasy and rough work is carried on here. The vegetables, dishes, cooking utensils, &c., are usually washed in portable iron or wooden tubs set apart for such purposes; the dirty liquids being afterwards emptied into the sink.

Figs. 27 and 28 are illustrations of the ordinary pattern of stoneware scullery-sink. They are comparatively shallow, and as no solid plug is provided to the outlet, therefore no overflow is needed. The waste-pipe from the sink must be



Fig. 29.

trapped immediately under the outlet, and afterwards carried directly through an external wall, so as to discharge over a trapped surface gully. A small anti-siphonage pipe should also be fixed near the crown of the siphon trap, and carried through the outer wall into the open air so as to prevent the water-seal of the trap being broken.

Trapped surface gullies intended for the reception of greasy liquids, as from scullery sinks, &c., must be suitably arranged for the purpose. They should be frequently cleansed by means of the discharge from a small automatic flushing tank. Where large quantities of greasy liquid are discharged, a grease-trap is frequently fixed, the accumulations of grease being then periodically removed by hand from the trap. For large mansions, hotels, &c., separate sinks for washing-up purposes are provided. These are made much deeper than the ordinary form of scullery sink, and are fitted with a solid plug and overflow or a combined plug and standing waste, so that they may be filled with water when required.

Fig. 29 shows a glazed stoneware sink fitted with a visible standing overflow and plug. The top of the overflow is protected by a movable perforated grating to prevent the passage of solids of large size. In this instance the waste is shown

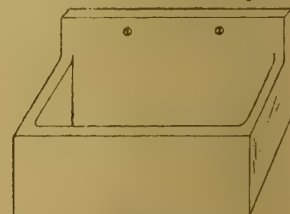

Fig. 30.

fixed to a sink of stock pattern, but it should preferably be placed in a small recess at the side.

An illustration of what is known as a "high back" sink is shown in Fig. 30.

The wash-up sink, shown in Fig. 31—and known as Shank's "Modern" sink—is made in white-glazed fireclay, the outlet being arranged within a small recess at the back, so as to be well out of the way when the sink is being used.

Fig. 32 is the sketch of a combined sink and drainer, formed in one piece of white-glazed fireclay. When in use, a movable wooden grating, or a fluted board of elm or teak is placed on the sloping drainage surface to receive the dishes or utensils after being washed, and thus minimise any risk of breakages.

When separate sinks are provided for washing vegetables, &c., glazed stoneware or fireclay is admirably adapted for the purpose, but for washing dishes, plates, and other ware, they are a fruitful cause of breakages, unless very great care is taken. To avoid this, a loose wooden grating is sometimes fitted to the bottom of the washing-trough.

Enamelled iron wash-up sinks may also be obtained; but they possess no sanitary advantages over those of well-glazed stoneware or porcelain.

Sinks which are chiefly or entirely intended for washing-up crockery are usually made of wood, lined with lead or copper. Lead-lined kitchen sinks consist of a box of well-seasoned



pine or deal, about 12in. deep, and lined inside with sheet lead. The bottom of the sink must be sloped towards the outlet of the waste, which should preferably be provided with an exposed standing overflow. The sheet-lead used for lining

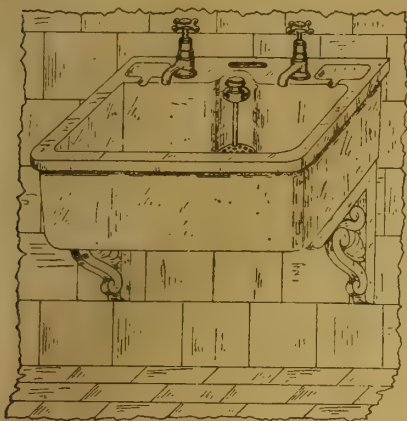

Fig. 31.

purposes must be extra stout, that for the bottom weighing not less than 12lb. per superficial foot, and 8lb. lead for the sides.

A section through a lead-lined wash-up sink is shown in Fig. 33. The trough is made of 1½ in. wrought yellow pine, dovetailed at angles, the bottom tongued into the sides and ends, and the whole put together with white-lead. All the interior angles are filled in with a small triangular or hollow fillet, in order that they may be well rounded. Sheet-lead is then dressed over the top edges and close copper-nailed thereto, all the joints being securely soldered. The sink is

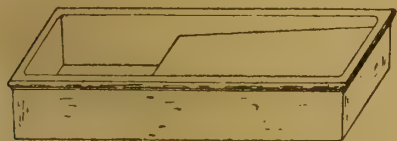

Fig. 32.

finished with a teak or other hard-wood capping secured with brass caps and screws. A perforated brass hollow plug and waste is provided to the outlet, together with a 2in. diameter lead trap and waste-pipe. An anti-siphonage pipe is fixed near the crown of the trap, the waste being arranged to discharge into (or over) a trapped surface gully outside.

A slate or marble slab is sometimes fixed at the back of the sink, or the surface of the wall finished with tiles, or rendered smooth in cement. Frequently the sink is provided with a hard wood

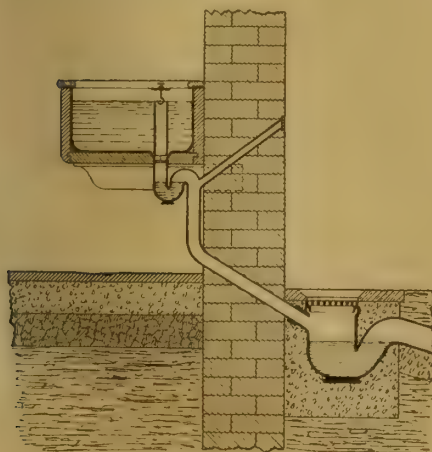

Fig. 33.

cover or top, which is designed to act as a draining board when any washing-up is taking place. Lead-lined sinks insure an impervious and at the same time a soft and yielding surface which is most desirable for washing-up purposes; but the

susceptibility of the metal when subject to extremes of temperature causes it to expand and contract considerably. The metal then rises in ridges or folds, and these, after a time, wear into holes, thus necessitating constant soldering and repair. For this reason copper-lined sinks are to be preferred, as they practically possess all the merits of sheet-lead without its corresponding disadvantages. Tinned sheet-copper for the bottom should weigh about 3½ lb. per foot superficial, and 2½ lb. for the sides. The remaining details of construction are similar to those just mentioned for lead-lined sinks (see Fig. 33).

Fig. 34 is an illustration of Jennings's copper-lined wash-up sink, provided with two compartments, the ware being washed in one and afterwards rinsed in the other. Each compartment is provided with an exposed standing overflow and waste, the wood capping and grooved draining-boards being of teak.

BUTLERS' PANTRY SINKS.

These are entirely reserved for washing-up glass, china, and other fragile articles which require a more careful handling than is usually obtained in the average kitchen. As indicated by the name, they are generally fixed in the butler's pantry. A lead- or copper-lined sink, similar to those already described, should generally be provided in preference to stoneware, fireclay, or enamelled iron, so as to reduce the risk of breakages to a minimum. The pantry sink may also be advantageously divided into two compartments, for washing and rinsing respectively, whilst the draining-board may be of plain grooved teak, or covered with lead, pewter, or copper. Sinks are sometimes made entirely of wood, the metal lining being omitted. Such a construction is not only objectionable on sanitary grounds, but they

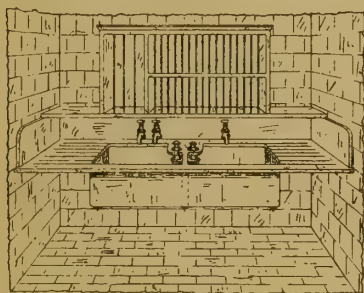

Fig. 34.

are also quite unfitted to withstand constant wear and tear.

HOUSEMAIDS' WASHING-UP SINKS.

Glazed stoneware or porcelain sinks are largely used for this purpose; but unless care is exercised they are apt to prove destructive to toilet-bottles and jugs when these articles are being cleaned and refilled with water. If preferred, a copper or lead-lined sink may be substituted as being less dangerous to bedroom ware. The sink should be conveniently placed for serving the bedrooms, whilst both hot and cold water should be laid on for the convenience of the servant.

Sinks similar to those shown in Figs. 29 and 30 may be used for housemaids' washing-up purposes. The standing overflow and waste shown in Fig. 29 should be placed in a small recess at the side or back. The waste from the sink must be properly trapped, and discharge into a vertical waste outside the building. The upper end of the vertical external waste should be carried above the eaves, whilst the lower end is arranged to discharge into or over a trapped surface gully. An anti-siphonage pipe should be fixed near the crown of the trap under the sink, and connected to the vertical waste outside, so as to properly maintain the water-seal of the trap. In many instances the housemaids' washing-up sink and slop-sink are combined so as to practically form one fitment. The waste-pipe from the wash-up sink may then be arranged to discharge into the basin of the slop-sink, instead of being separately carried outside the building.

HOUSEMAIDS' SLOP-SINKS.

As these conveniences are intended to receive the slops and other fouled liquids from bedrooms, it is necessary that they should be designed and fixed on similar lines to those laid down for waterclosets. In fact, for small houses the

watercloset also acts as the slop-closet to the dwelling. For buildings where a separate slop-sink is required, the simple and inexpensive pattern shown in Fig. 35 is largely used. It is suitable for the corner of a housemaid's room, and stands within a glazed stoneware safe. The sink is of the same general form as a wash-down closet, and must be fixed in the same manner.

LAUNDRY SINKS OR TROUGHS.

Fixed laundry sinks or troughs are not usually considered necessary for small houses. The soiled linen is either washed at stated intervals in a

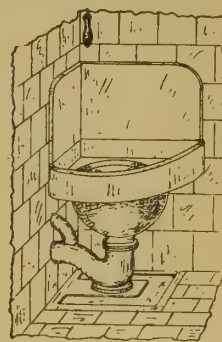

Fig. 35.

portable galvanised iron or wooden washing trough, or else sent to a public laundry. For large mansions, hotels, and other similar establishments where a certain amount of washing must be constantly carried on, an outbuilding is usually set apart for this particular purpose, and fitted up with a series of laundry troughs and other appliances according to requirements.

Fig. 36 is a sketch of a white enamelled fireclay laundry sink or washtub arranged with soap-trays and holes for hot and cold water supply-taps. A 2in. diameter waste, fitted with brass washer, chain, and vulcanite plug, is fixed in the bottom of each trough. Where a range of troughs is provided, the wastes may discharge into a surface channel formed in the floor, which, in its turn, discharges over a trapped gully outside. The surface channel should be frequently and thoroughly cleansed by hand. Instead of discharging into a surface channel, the wastes are sometimes connected by means of a main waste-pipe designed to discharge outside; but the pipe soon becomes foul with soapy and other matters, and cannot be readily cleansed.

Owing to the great weight of fireclay and stoneware wash-tubs, they are usually supported on white enamelled piers of the same material, instead of brackets. The edges of the supports

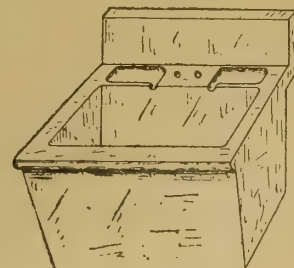

Fig. 36.

should be well rounded, and the piers so constructed that the space under the troughs may be easily kept clean.

Where a large amount of rough treatment is anticipated, strong wooden troughs are frequently used. They are made of well-seasoned yellow deal or pine 1½ in. thick, wrought, grooved, tongued, and bolted together with ¾ in. copper or gunmetal bolts, the joints being put together with white-lead. The front is made to slope slightly towards the bottom. The internal dimension of each trough is usually about 2ft. 6in. by 1ft. 6in., and 1ft. 3in. deep. Wooden laundry troughs are inferior to glazed fireclay sinks from a sanitary standpoint, owing to the porous and absorbent nature of the material used in their construction.

## THE PROPOSED REGISTRATION OF ARCHITECTS.

UNDER the auspices of the Society of Architects, a meeting was held at the Arts Club, Grainger-street, Newcastle-on-Tyne, on Monday night, to consider the question of the statutory registration of architects. There was a fair attendance. Mr. S. Trevail, F.R.I.B.A., of Truro (vice-president), occupied the chair. It was announced that a large number of replies had been received from well-known architects, encouraging the promoters to persevere in their endeavours to obtain registration. Mr. ELLIS MARSLAND, of London (hon. secretary), gave an address, in which he traced the history of the movement which they were met to discuss. In 1886 circulars were issued, embodying registration proposals, and 1,300 replies were received, with the result that a Bill was introduced in the House of Commons. That Bill included architects, engineers, and surveyors. In 1893, however, a Bill was introduced dealing with architects alone, and had been brought in every year since, being down for reading again in April next. Before success could be looked for, it would be necessary to show that there was something like unanimity among architects on the subject. The Society of Architects was organising a series of meetings in the chief provincial centres, and if it should be found that there was a preponderance of opinion in favour of registration, they would make strong efforts to carry it out. Registration would mean that every man practising architecture was duly qualified by examination. It would close the doors to incompetent men, raise the standard of the profession, secure the confidence of the public, and receive State recognition. It was not proposed for one moment that all who desired to build should employ an architect; but if registration were adopted, henceforth no person who was not qualified would be entitled to call himself an architect. Registration would enable every one to ascertain who were properly qualified. One of the first effects of registration would be to put a stop to the increase of incompetent practitioners. Mr. J. W. Dyson, of Newcastle, moved the following resolution:—"That this meeting cordially approves the principle of the statutory examination and registration of architects, and is of opinion that it is desirable, in the interests of the public and the architectural profession, to promote a Bill in Parliament for the attainment of this object." Mr. Dyson added that they were not in opposition to the Royal Institute; but what, he asked, was the use of an examination unless there were some recognition of it afterwards? Mr. ORD, of Durham, seconded the resolution. Some discussion followed, in which it was suggested that pressure should be brought to bear on the Royal Institute of British Architects to support the registration proposals. One speaker pointed out that it was much more necessary that architects should be registered than plumbers, though he was ready to admit that the latter were a useful and important body of men. Qualified architects had to submit to many disadvantages because of the absence of registration, which, if adopted, would not merely benefit the profession, but would be distinctly in the public interest. The resolution was carried unanimously; and it was resolved that it should be sent to the members of Parliament for constituencies in Northumberland and Durham. Another suggestion which found favour was that the signatures of as many architects as possible be obtained to a petition embodying the resolution.

A new hospital for hip diseases is about to be built on a site of 3½ acres at Tub's Hill, Sevenoaks, the present buildings in that town being quite inadequate. Mr. T. G. Jackson, R.A., is the architect.

A special meeting of the Derby Town Council was held last week for the purpose of electing a candidate to fill the office of borough surveyor in succession to the late Mr. R. J. Harrison. The salary is £600 a year, rising to £750, and there were upwards of 80 candidates for the post. These were reduced to four—namely, Mr. Wm. Dyack, Burgh engineer, Aberdeen (who retired before the voting took place); Mr. R. S. Routhwaite, borough surveyor of Sunderland; Mr. Howard Smith, engineer of Lynton and Barnstaple (formerly city surveyor of Carlisle), and Mr. John Ward, assistant city surveyor of Sheffield. Mr. Ward was elected, the first choice lying between him and Mr. Howard Smith.

## OBITUARY.

MAJOR T. A. SKELTON, J.P., architect and surveyor, of Portland-street, Southampton, and of Oakfield, Bitterne, a justice of the peace for the borough, died at Burlington, Shirley, on Friday morning. Some few years ago the deceased gentleman, whilst at Plymouth on business, had a paralytic seizure, from which he really never wholly recovered, although until a short time ago he was able to carry on his professional duties. Major Skelton for a long period was connected with the Southampton Rifle Volunteers, and was formerly secretary of the Conservative party. Major Skelton was added to the Commission of the Peace for the borough on the 27th June, 1892. He leaves a widow and family. Mr. Skelton was a native of Southampton, being a son of Mr. T. Skelton, printer and lithographer. Before his illness he was intimately identified with several commercial undertakings, and aided much in the development of the St. Denys estate, and of estates at Midanbury, Bitterne, and Lyndhurst-road. One of his inventions, which he patented, received much attention from gas engineers and others interested in improved gas illumination in the days when the electric light was yet in its infancy. This was the catoptric lamp, the main feature of which was that the upward rays of the flame from the gas burner were reflected by an ingenious arrangement fitted within the lamp and thrown downward, the light being thus practically doubled. Mr. Skelton was the architect of the present Southampton Workhouse, his plans being selected in competition. He was a well-known amateur astronomer.

MR. JAMES BARWELL, founder of the firm of Messrs. Barwell and Sons, brassfounders, &c., of Great Hampton-street, died at his residence, Hampton-road, Edgbaston, early on Tuesday morning. The deceased gentleman, who was in his 81st year, was a native of Birmingham, and took a good deal of interest in its institutions. Mr. Barwell was a governor of the Bluecoat School for fourteen years, and a prominent supporter of the Church Pastoral Aid Society and the Church Missionary Society. He was a very strongly-pronounced Conservative; but his urbane manner and kindly disposition won for him the esteem of friends of all parties.

The new Wesleyan Methodist Sunday-school, Willington, Co. Durham, has now been completed at a cost of about £900. The architect was Mr. H. T. Gradon, of Durham.

The activity which has been prevalent at the Auction Mart for some time past was fully maintained last week. The aggregate realisation was £165,897, as compared with £102,717 registered for the same period in 1897, thus placing this year, which already holds a considerable lead over its predecessor, still further in advance. The demand for licensed properties has recently slackened, and there can be no doubt that prices have been unduly inflated during the last two years.

The Massachusetts Institute of Technology at Boston is about to make a large addition to the building already occupied by its architectural and engineering departments. The new structure will contain a new laboratory for the department of mechanical engineering, three lecture and recitation rooms, a modelling room, and drawing rooms for the architectural department, the architectural library, gymnasium for women students, and laboratories for the department of biology. In the upper story will be an architectural museum, and some rooms devoted to industrial chemistry.

A general meeting of the heritors of Coldingham has been held in the Priory Church of that parish. The object of the meeting was to receive the report of a committee appointed to inquire as to the preservation of the remains of the old Priory. The committee reported that they had had the benefit of the advice of Mr. A. J. Heiton, architect, and they now recommended that, as a first step, the heritors should authorise them to have the lines of the exterior walls marked out on the turf wherever that could be done without interfering with the graves in the churchyard. The committee further recommend that, when the lines of the old building have been thus ascertained, sepulture should, as far as possible, cease within the old church. Mr. Usher, in moving the adoption of the report, said that, as regarded a suggestion of probable restoration of the Priory, there was really nothing left that could be restored or preserved except the portion of the Priory—the choir—in which they were met. It would not be of practical utility to rebuild the Priory as a model of what had been there.

## COMPETITIONS.

BOSCOMBE.—The design submitted by Mr. G. A. Bligh Livesey, A.R.I.B.A., Salisbury Chambers, Boscombe, and Bournemouth, has been placed first, and gained him the premium awarded in open competition for the proposed rebuilding of the Boscombe Hospital. The cost of the entire scheme, which will be carried out in sections, is about £10,000. The assessors were Messrs. Young and Hall, of London.

PUTNEY.—A new public library is to be built at Putney, and a limited competition of designs submitted by the following chosen architects has just been held and decided, a first premium of thirty guineas, and a premium of twenty guineas to be paid to the remaining competitors—viz., Messrs. Maurice B. Adams, F.R.I.B.A.; G. L. and G. R. Crickmay, F.R.I.B.A.; S. W. Lee, F.R.I.B.A.; S. Perks, A.R.I.B.A.; and S. R. J. Smith, F.R.I.B.A., the author of the first premiated plan being Mr. F. J. Smith, F.R.I.B.A., whose design has been provisionally chosen subject to the modification of the elevation. The site is in Disraeli-road, and the cost is limited to £8,000.

WADEBRIDGE.—For memorial schools at Wadebridge, Cornwall, fourteen sets of designs were received from different architects, and those prepared by Messrs. Kerley and Ellis, of Exmouth, have been selected as the best. Working drawings and specifications have been made by the above-named architects, who are now inviting tenders for carrying out the work.

## CHIPS.

The room facing Queen's Bench Judges' chambers at Royal Courts of Justice, hitherto used for arbitration meetings, is being fitted up as a court, and will in future be known as Queen's Bench Court X. There will be a raised bench for the judge, and a witness-box, but the new court will not be available for jury cases.

A new chapel has been erected at Llandrinod, Wells, and special consideration has been given to the ventilation, which is carried out on the Boyle system.

The additions to the Boothferry-road board schools, Goole, are being warmed and ventilated by means of Shorland's patent Manchester stoves, those previously supplied having proved very satisfactory.

M. Falguière's statue of Dr. Charcot, one of his finest works, is shortly to be placed in the Cour de l'Hospice de la Salpêtrière, Paris.

The death is announced of Mr. Thomas Rigby, manager to the Bury Corporation Waterworks. He was a prominent Freemason in East Lancashire. After being secretary to the old Bury Waterworks Company, he was, on the incorporation of the borough, appointed manager of the now extensive Bury Waterworks undertaking.

At Marlborough-street Police-court, on Tuesday, George Veale, a builder, of Dunsmore-road, Stamford Hill, was summoned for obtaining £600 by false pretences from Edward Collins, managing clerk to a firm of solicitors. Evidence was given that the prisoner borrowed this sum, making a statutory declaration at the time that £1,000 was due to him by a brewery company, but that the prosecutor had since found out that a receiving order in bankruptcy had been made against the defendant. The further hearing was adjourned.

Mr. Robert Treloar, of 27, Peckham-road, Camberwell, formerly of Elham, and of the firm of Treloar and Sons, cocoa fibre manufacturers, Ludgate Hill, who died on March 13 last, aged 53 years, left personal estate of the value of £16,413 19s. 1d. He appointed as executor his brother, Mr. Alderman William Purdie Treloar, of Ludgate Hill, and left to him all his real and personal estate absolutely.

The opening services at a new Wesleyan school-chapel in Ladypit-lane, Beeston Hill, Leeds, took place on Monday. Mr. G. F. Danby, Leeds, is the architect of the building, which is a plain structure, built of brick, with stone dressings, and affords accommodation for 250 worshippers. There are three classrooms. The cost has been £1,400. Mr. W. Schofield had the contract for the brick and stone work, and Messrs. J. Tomlinson and Son that for the wood work, a large portion of which is of pitch-pine.

An oil painting by Scott of the Pantiles, Tunbridge Wells, at the close of the last century, has just been presented to the corporation of Tunbridge Wells by Mrs. J. Stone Wigg, as a memorial of her late husband, the first mayor of the borough. The picture will be hung in the municipal gallery, which already possesses two old water-colours of the Pantiles.

CONTENTS.

Safety of Staging ... 441  
 Society of British Artists ... 441  
 Model Specifications.—VI. ... 442  
 The Society of Architects ... 444  
 The Architectural Association ... 445  
 Sanitary Work.—III. ... 448  
 The Proposed Registration of Architects ... 450  
 Obituary ... 450  
 Competitions ... 450  
 THE BUILDING NEWS DIRECTORY... xi.  
 Our Illustrations ... 451  
 Building Intelligence ... 470  
 Professional and Trade Societies ... 470  
 Correspondence ... 471  
 Intercommunication ... 471  
 Legal Intelligence ... 472  
 Parliamentary Notes ... 472  
 Our Office Table ... 473  
 Meetings for the Ensuing Week ... 474  
 Trade News ... 474  
 Latest Prices ... 474  
 List of Competitions Open ... 475  
 List of Tenders Open ... 475  
 Tenders ... 478

ILLUSTRATIONS.

DESIGN FOR THE DIAMOND JUBILEE MEMORIAL HALL, WOLVERHAMPTON.—TECHNICAL SCHOOL, BOOTLE.—ALHAMBRA THEATRE, ATTERCLIFFE.—FOUR DEVELOPMENTS OF PLAN FOR A HOUSE COSTING ONE THOUSAND POUNDS.—DESIGNS FOR SIMPLE BEDROOM AND DINING ROOM.—CONGREGATIONAL CHURCH, RICHMOND.—STAIRCASE HALL, AULDWOOD.

Our Illustrations.

WOLVERHAMPTON PUBLIC LIBRARY.

The desirability of placing the main entrance immediately facing Snow Hill has, in common with the first premiated plan,\* been recognised in the accompanying design; but the placing of the reference-room along Garrick-street, which is a much quieter street than Cleveland-road, entirely reverses the general contrivance of the scheme as compared with the plan chosen. The curved outline of the frontage, the restrictions as to light on the N.E. boundary of the site, and the very large area stipulated for the lending-library, formed the leading points of the problem, which was unduly hampered by an equally stringent condition as to limitation of cost. The difficulty of lighting ground-floor rooms 50ft. wide by side windows only, has been avoided in this plan, which also has the distinct advantage of conveniently separating the administrative departments of the library from the public part of the building. The waterclosets are placed to the rear, and away from the main entrance. The caretaker's rooms are central, and are reached without passing through any of the public apartments, or the necessity of going outside the building. To economise space, the heating-chamber is located in a half-basement, in the midst of the work to be done by the apparatus. A site is reserved in this plan for the librarian's house. Passages are reduced to a minimum, and the staff can control all the public rooms without leaving the private part of the premises. All the rooms are of the specified areas. The borrowers' space provides counter room for nine indicators, besides seven hatchways and an inquiry counter. Wall room is contrived for the exhibition of the framed displayed catalogue in accordance with the system used at Wolverhampton. Six indicators at least are necessary to work a lending library of two-thirds the dimensions given, and nine certainly will be required when this library is in full work. The reference books in this plan are as close to their readers as the lending library books are to the borrowers. The librarian is situate in the centre of both departments, which are thus under his immediate control, and yet his room is quite private and the working can go on without his being disturbed. The committee approach to this room for meetings has the advantage of being shut off from the public. Terracotta for the dressings being stipulated, the necessity of repeats and smallness of detail had to be recognised, and so had the condition as to the building being made to accord with the idea of a Diamond Jubilee Memorial. These particulars

\* See BUILDING NEWS for March 25, 1898.

are condensed from the report accompanying this design, which was made by Mr. Maurice B. Adams, F.R.I.B.A., in this limited competition.

TECHNICAL SCHOOL, BOOTLE, LIVERPOOL.

The competition for the proposed technical school at Bootle was decided some few months ago. The town council received twenty-two sets of plans and designs for the buildings, the estimated outlay being £15,000, and called in as assessor Mr. W. E. Willink, A.R.I.B.A., of Castle-street, Liverpool. Acting upon his advice, they resolved, on the recommendation of the Free Library and Museum Committee, to divide the first and second premiums, together amounting to 80gs., between Messrs. Best and Callon, of Prince's Mansions, Victoria-street, Westminster, and Messrs. Woodhouse and Willoughby, 100, King-street, Manchester, and to award the third premium of 20 guineas to Mr. A. J. Rowley, of High-street, Oxford. Although the merits of the first two designs were obviously so evenly balanced that the assessor could not see his way to place either distinctly first, Mr. Willink advised that the plans of Messrs. Best and Callon were "better adapted to meet the requirements of the school," and this view being adopted by the town council, that firm have accordingly been appointed as architects for the building. The accommodation provides for the usual classrooms and workshops, lecture-rooms, and laboratories, as well as an examination hall to seat from 280 to 300 students. The site is in Balliol and Pembroke-roads. We are promised by the selected architects, Messrs. Best and Callon, of Westminster, that we shall have the loan of their drawings, so that we propose to illustrate the chosen design at an early date.

ALHAMBRA THEATRE OF VARIETIES, ATTERCLIFFE ROAD, SHEFFIELD.

This theatre was opened last January. The front elevation faces the Attercliffe-road. The lower portion of the front is of stone, resting on a base of coloured glazed bricks. The upper part of the two sides of the building is of red brick, the centre being of stucco with carved heads to the windows. The flanking portions on either side, which are devoted to staircases, are carried up to form towers, and these are terminated by lead cupolas and flagstuffs. Arc lamps are suspended over the main portion of the building, and the windows being of stained glass with electric lights behind them, light up the building. The interior of the house is decorated with Moorish designs, and all the fittings are in keeping. The seating accommodation consists of ground-floor area, with a gallery over. There are four direct means of entrance or exit to the ground-floor seats, and two to the gallery. There is also a pass stair between the two parts. The stage has a separate entrance at the back of the building, and in close proximity are dressing-rooms and the manager's office. The building is of fireproof construction, and hydrants are provided in case of emergency. The lighting throughout consists of a duplicate system of electric light and gas, the former being supplied by an engine and plant laid down for the purpose; the gas is only provided in case the electric light should at any time unexpectedly not be available. The theatre has been erected for the Attercliffe Alhambra Company from the designs and under the superintendence of Messrs. G. D. Martin and A. Blomfield Jackson, architects, both of London. The contractors are Messrs. G. Longden and Sons, of Sheffield.

FOUR DEVELOPMENTS OF ONE PLAN FOR A HOUSE COSTING ONE THOUSAND POUNDS.

THESE designs are by Mr. James Ransome, of London, and are based on some smaller houses of his planning at Wimbledon, Broadstairs, and Haslemere, &c. The sketches illustrate some possibilities of very varied treatment applicable to a plan in itself plain and square, while the arrangement of the rooms is interesting as showing the amount of accommodation that may be contrived within a very limited space. As such the sheet is suggestive.

TWO INTERIORS.

THESE designs, by Mr. Charles E. Varnell, are for two rooms of a country house. The dining-room, after the Jacobean style, is to be panelled in oak to a height of 8ft. 6in., above which will hang tapestries. The doors and shutters are to have ornamental dull steel hinges. The fireplace sides and hearth will be lined with long narrow red bricks, picked out for their brightness of colour and ruggedness in shape. The face of the

chimney-breast would be covered with old Dutch tiles. In the panelling, bookshelves are arranged, the seats being upholstered in a dark green leather. The plaster ceiling will be panelled with moulded oak ribs. In the bedroom an effort has been made to produce a simple and artistic room. The ceiling joists have been left showing, to give it an old-time character. The woodwork is to be in pine, stained a warm brown, and the furniture in ash, stained green.

CONGREGATIONAL CHURCH AND LECTURE HALL, RICHMOND.

MR. PHILIP E. PILDITCH is the architect of this building, of which no further particulars have reached us.

STAIRCASE HALL, AULDWOOD, SEABRIGHT, N.J.

WE have no particulars of this work, which has been carried out from the designs of Messrs. Shepley, Rutan, and Coolidge, architects, whose work, as here seen, is refined and suitable for its purpose and position. The scheme is, to some extent, based upon historic examples, and the style seems well adapted to modern requirements.

\*\* WE are informed that the two stained-glass cartoons published by us last week were designed for Messrs. Walter J. Pearce, Limited, of Albert-street, Manchester, who executed them for their own showrooms. This information was not in our hands when we gave the drawings referred to.

CHIPS.

The new Wesleyan Methodist day-schools at Sacristan, Co. Durham, are to be opened at Easter. Mr. H. T. Gradon, of Durham, is architect for both schools and church.

In memory of the former vicars of the parish, St. Martin's Church, Leicester, has been restored, and a new south porch, erected by subscription, has just been dedicated. The entrance is enriched by four full-length statues of Bishop Magee, St. Hugh, Bishop of Lincoln, Bishop Grostete, and St. Dunstan. These are the work of Mr. Nathaniel Hitch, of Vauxhall. About £800 is to be spent in renovating and improving the organ of the church.

Colonel C. H. Luard, C.E., held an inquiry at the Southport Town-hall on Friday week, on behalf of the Local Government Board, into an application by the Southport Town Council for power to borrow £21,178 for electric lighting and £18,070 for street improvements. The electric light extensions consist of the erection of a 600-unit engine and alternator combined, the laying down of two main cables to the town, and various works connected therewith.

A stained-glass window has been placed in Corstorphine Church, N.B. The window is of three lights with tracery, and is situated in the north transept. The designs are in six groups, illustrative of the Acts of Mercy. The artists are Messrs. Ballantyne and Gardiner, of Edinburgh.

The churchwardens of St. Mary-le-Quay Church, Ipswich, have received a report from Mr. E. F. Bishop, of that town, architect, stating that, owing to the spread of dry rot, the fine hammer-beam roof of the nave and the aisle roof are in an unsafe condition. They have, therefore, closed the church, and are appealing locally for funds for its restoration. The church, which is in a poor district, and is slenderly endowed, was built in 1448.

There are in course of erection naval workshops at Port Edgar, South Queensferry, N.B. These are to include carpenters' and shipwrights' departments and blacksmith's shop. The erection is some 50ft. by 40ft., and is laid with concrete flooring.

On Monday next, the Great Northern Railway Company will open an important link of their system in the Nottinghamshire district, consisting of a new line forming part of the Leen Valley extension. The railway joins the Leen Valley line at Annesley, and, when completed next year, will extend to Pleasley—a distance of nine miles; but at present the line has been carried as far as Skegby only, or a length of five miles. The railway gives access to collieries at Kirkby, Teversall, and Pleasley, and when laid throughout will also extend to the Shirebrook and Langwith collieries.

The Coventry and District Master Builders' Association have presented a petition to the corporation of that city calling attention to the requirements of the city surveyor with regard to workmen's houses, to the alleged unnecessary expense, and the impracticability of these requirements. The general purposes committee of the corporation have instructed the surveyor to report on the question. He has already stated that he simply enforced the city by-laws, which have been in force some years, and are founded on the model code of the Local Government Board.

CONGREGATIONAL CHURCH & LECTURE HALL  
RICHMOND · SURREY  
PHILIP E PILDITCH ARCHT

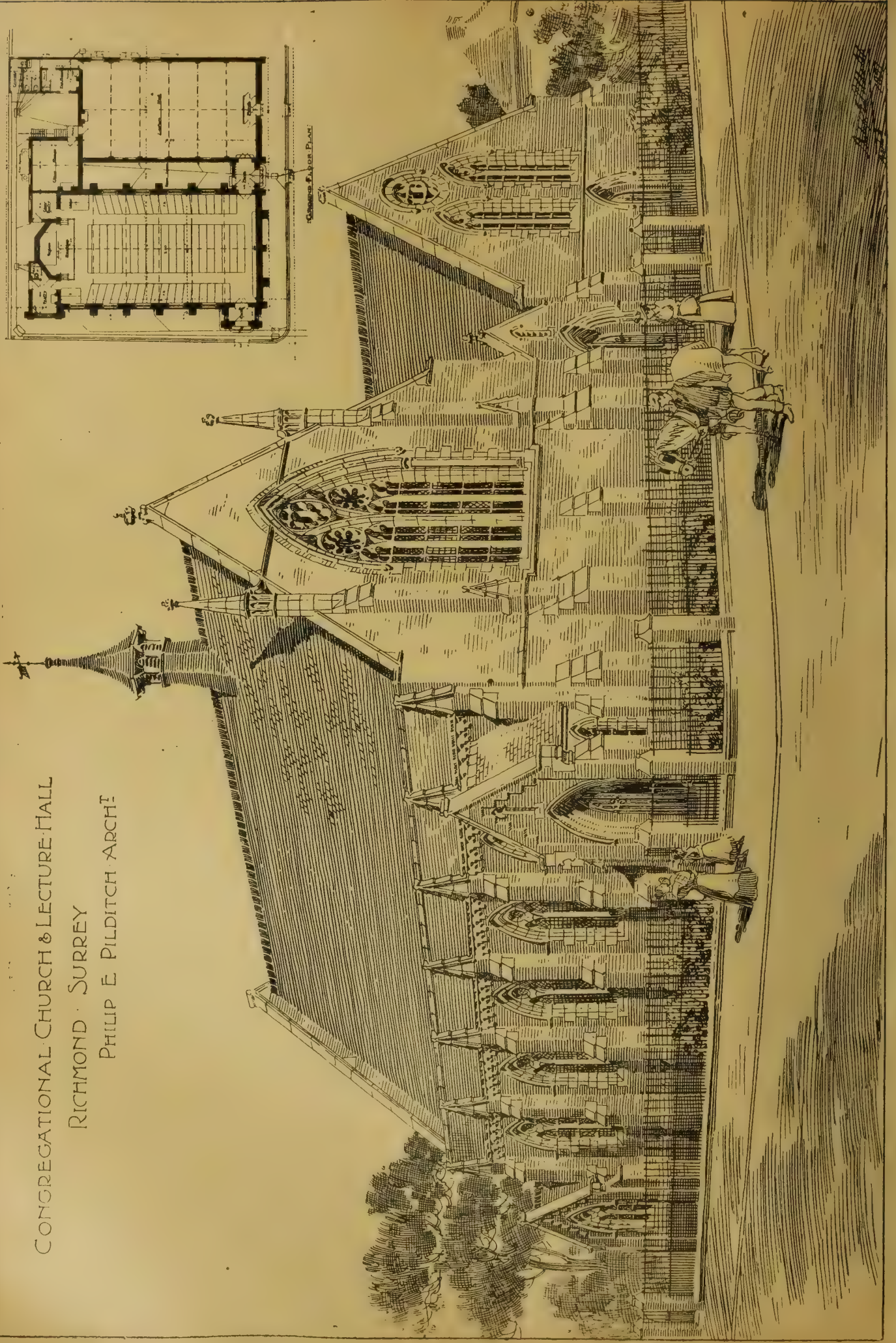



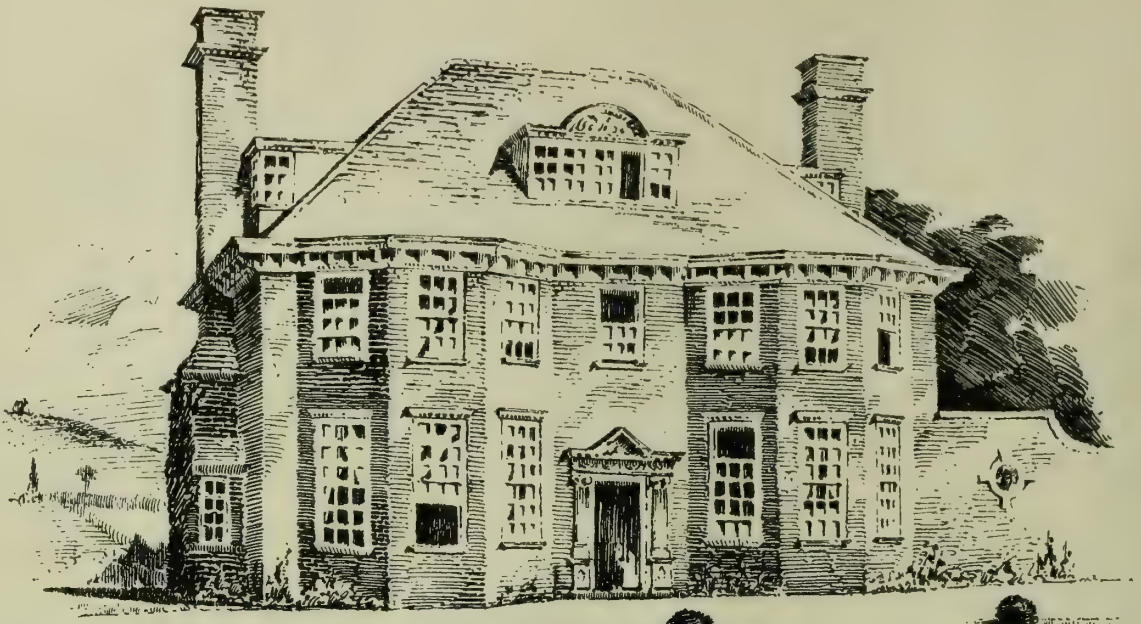

HOUSE A.

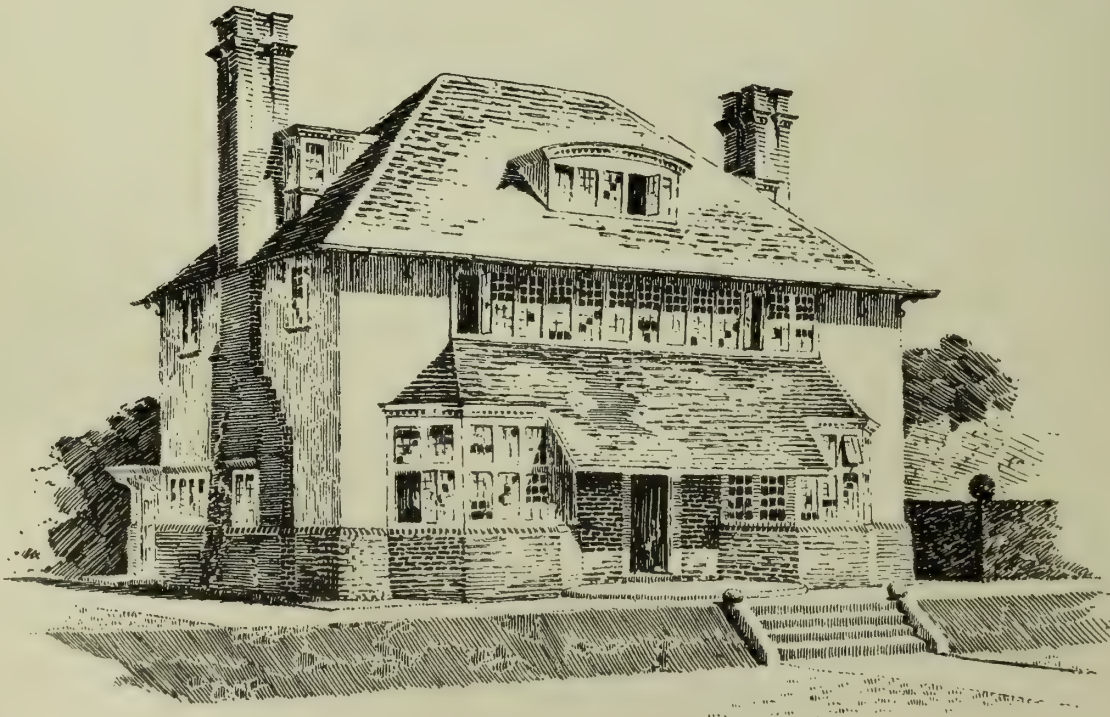
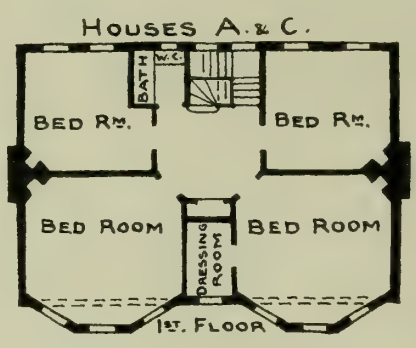
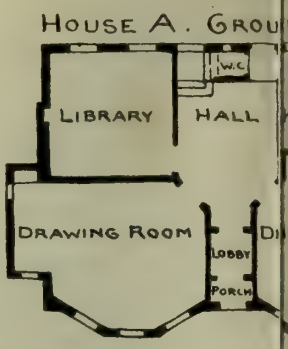

HOUSE C.



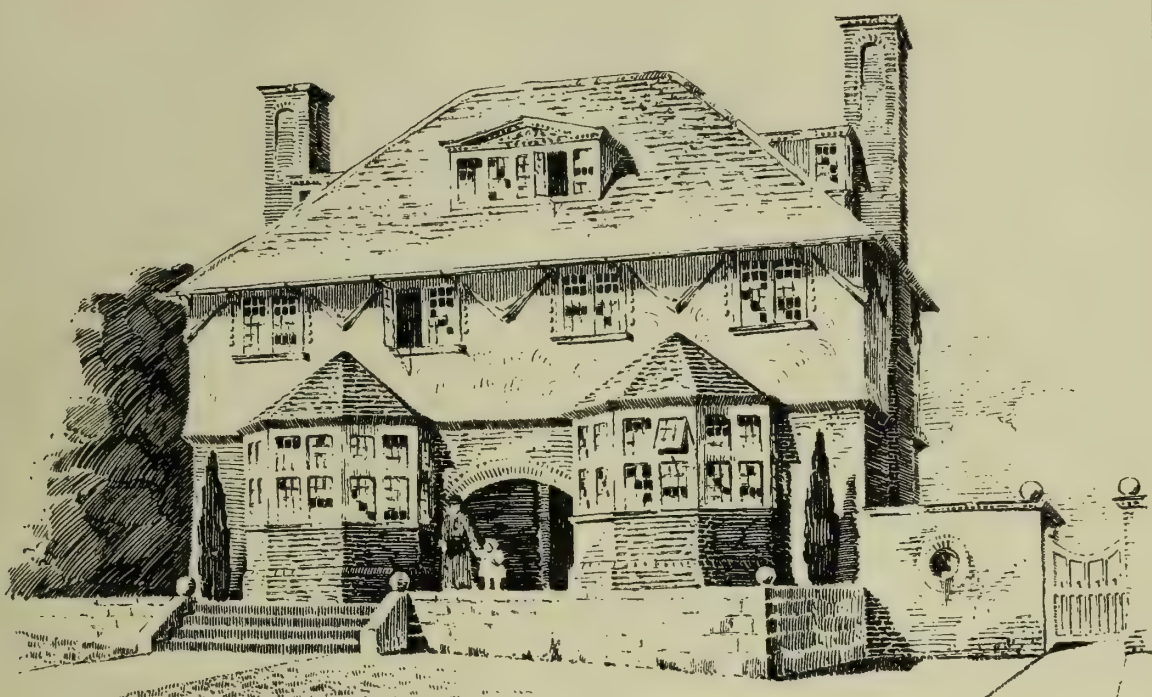

HOUSE B



HOUSES B. & D.

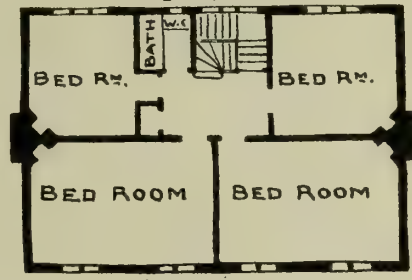

FIRST FLOOR



FLOOR



HOUSE D.

Photo Lithographed & Printed by James Akerman, 6, Queen Square W.C.







DESIGN BY MAURICE WATSON

SECOND FLOOR  
 MATERIAL AREAS  
 NEWS ROOM 257 1/2  
 MAGAZINE RM 106 9  
 WASTE ROOM 280  
 REPAIR ROOMS 350  
 LAUNDRY FOR STAFF AND  
 ROOMS FOR CARETAKERS

RRRR RADIATORS  
 FA FRESH AIR INLETS

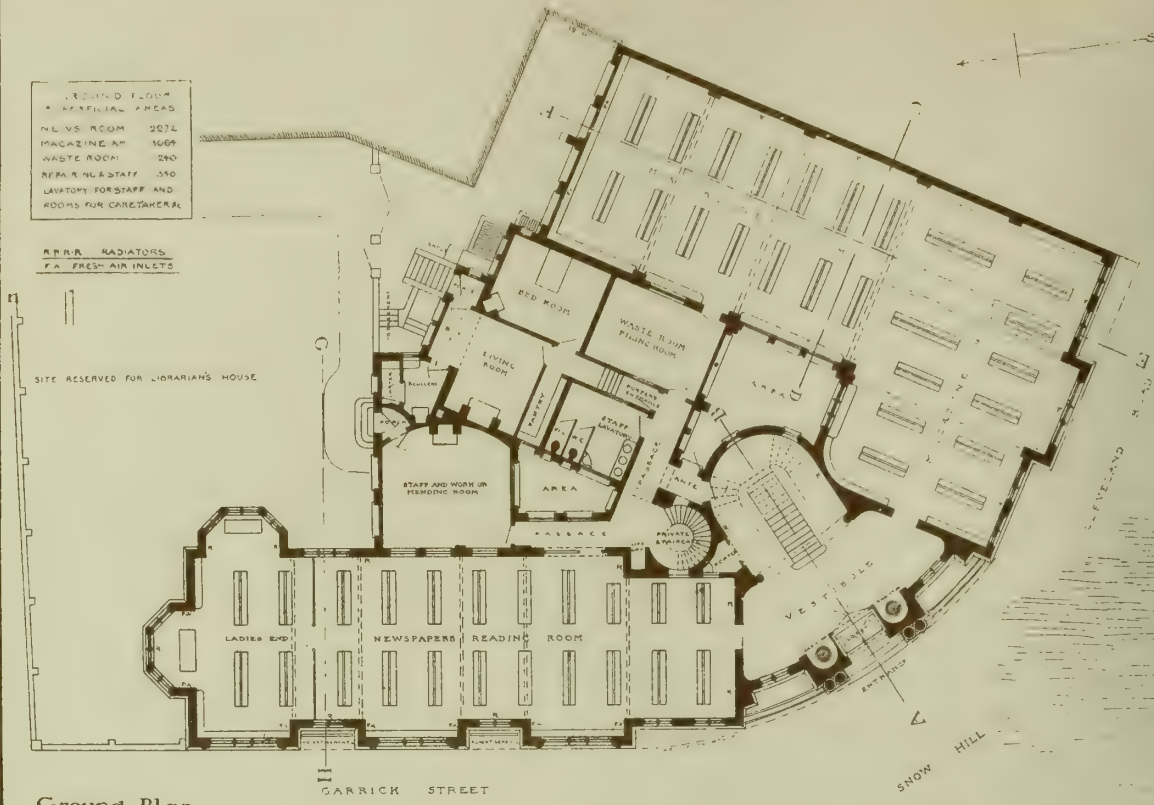

Ground Plan



DIAMOND JUBILEE MEMORIAL NEWS

CE B. ADAMS, F.R.I.B.A. ARCHITECT

REFERENCE LIBRARY 247 1/2  
 LENDING LIBRARY 425  
 COPIES & SHALFEN 174

HARRIS BALJOHNS  
 TA FRESH AIR INLETS

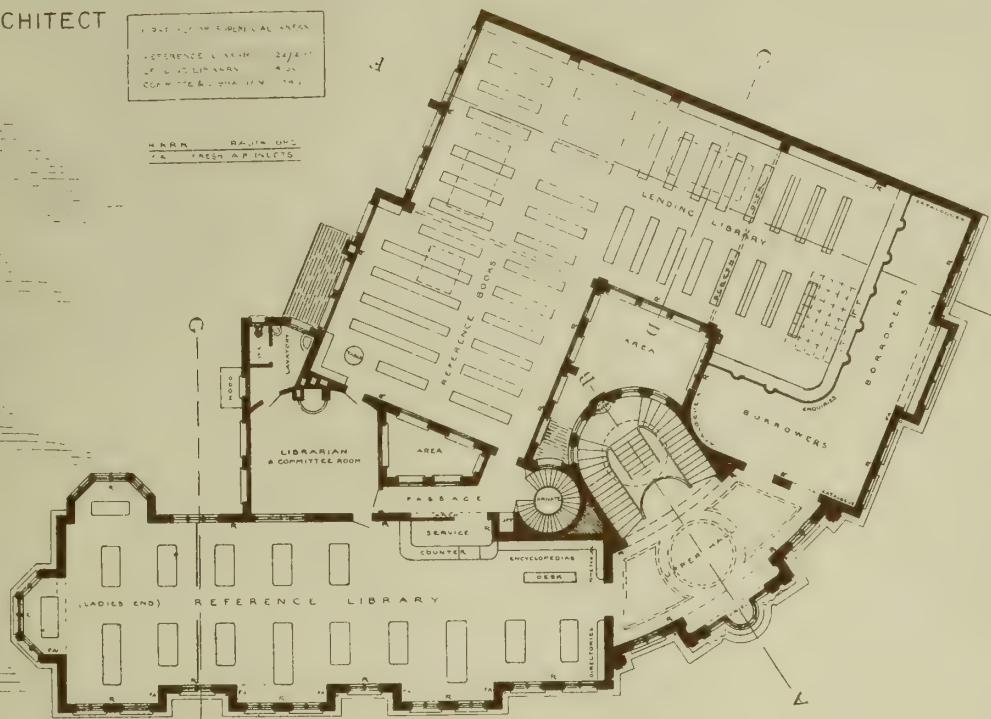

First Floor Plan

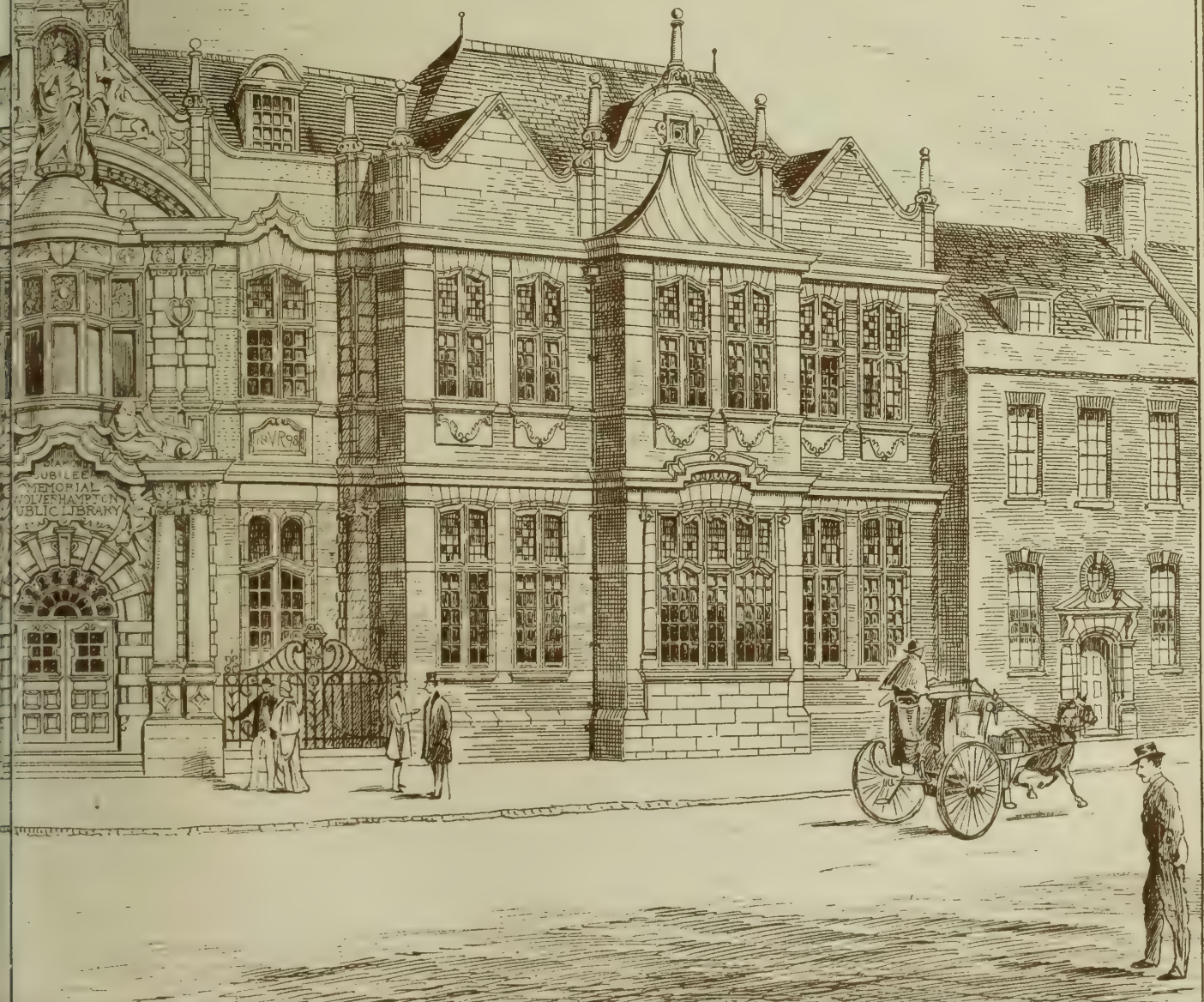





THE BUILDING NEWS APRIL 1. 1898.

BOOTLE INSTITUTE. PREMIATED DESIGN.

WOODHOUSE & WILLOUGHBY, ARCHITECTS

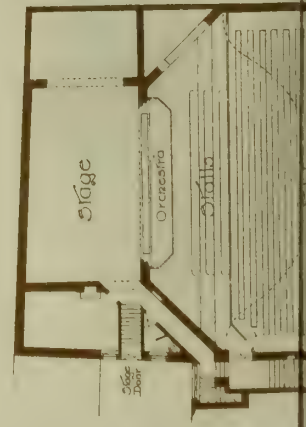

ALHAMBRA THEATRE,  
ATTERCLIFFE.

G. D. MARTIN & A. BLUMFIELD JACKSON, ARCHITECTS





"PHOTO-TINT" by James Akermat. Queen Square London W.C.







THE BUILDING NEWS APRIL 1, 1898.

A DINING ROOM  
IN JACOBINE STYLE

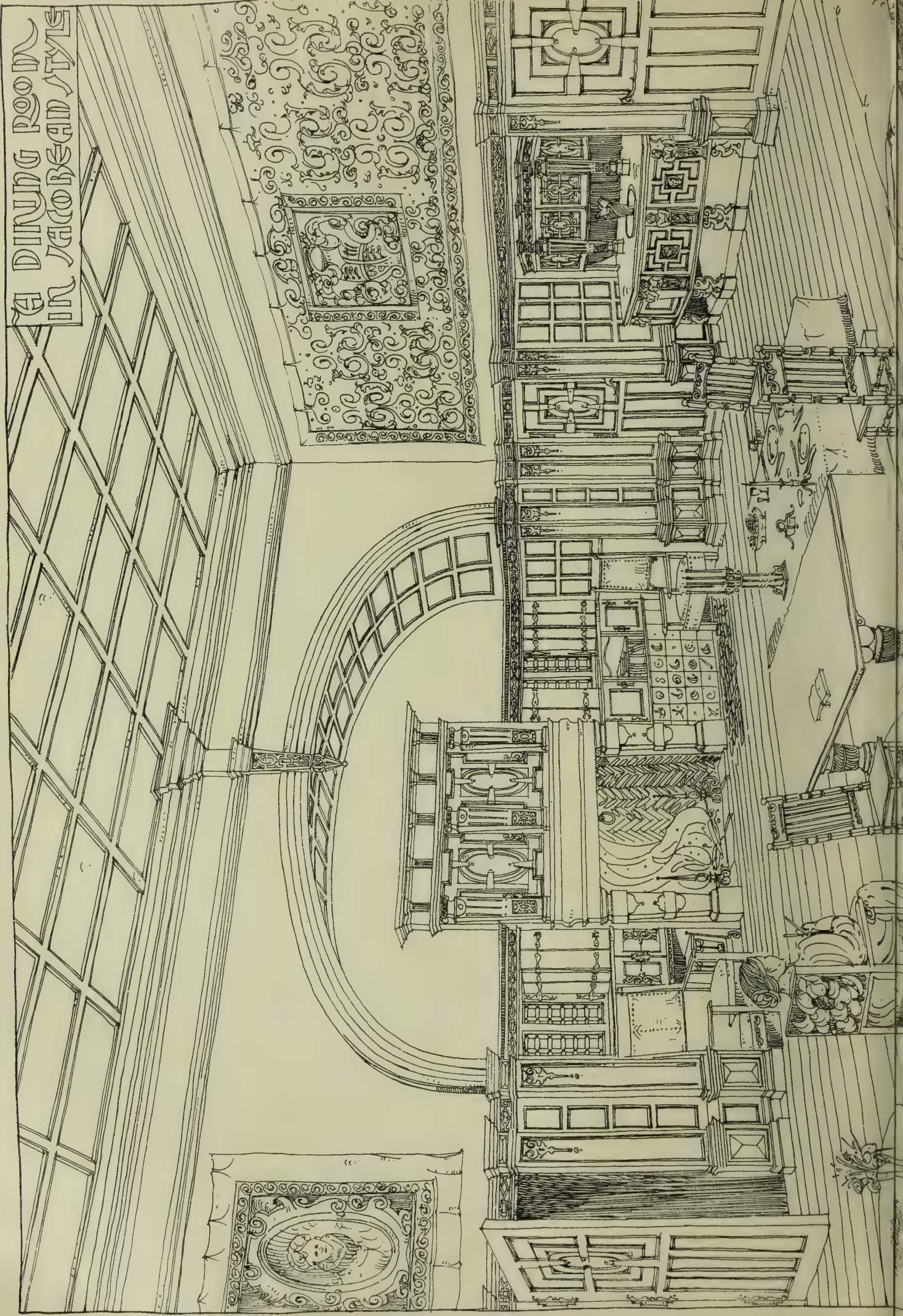

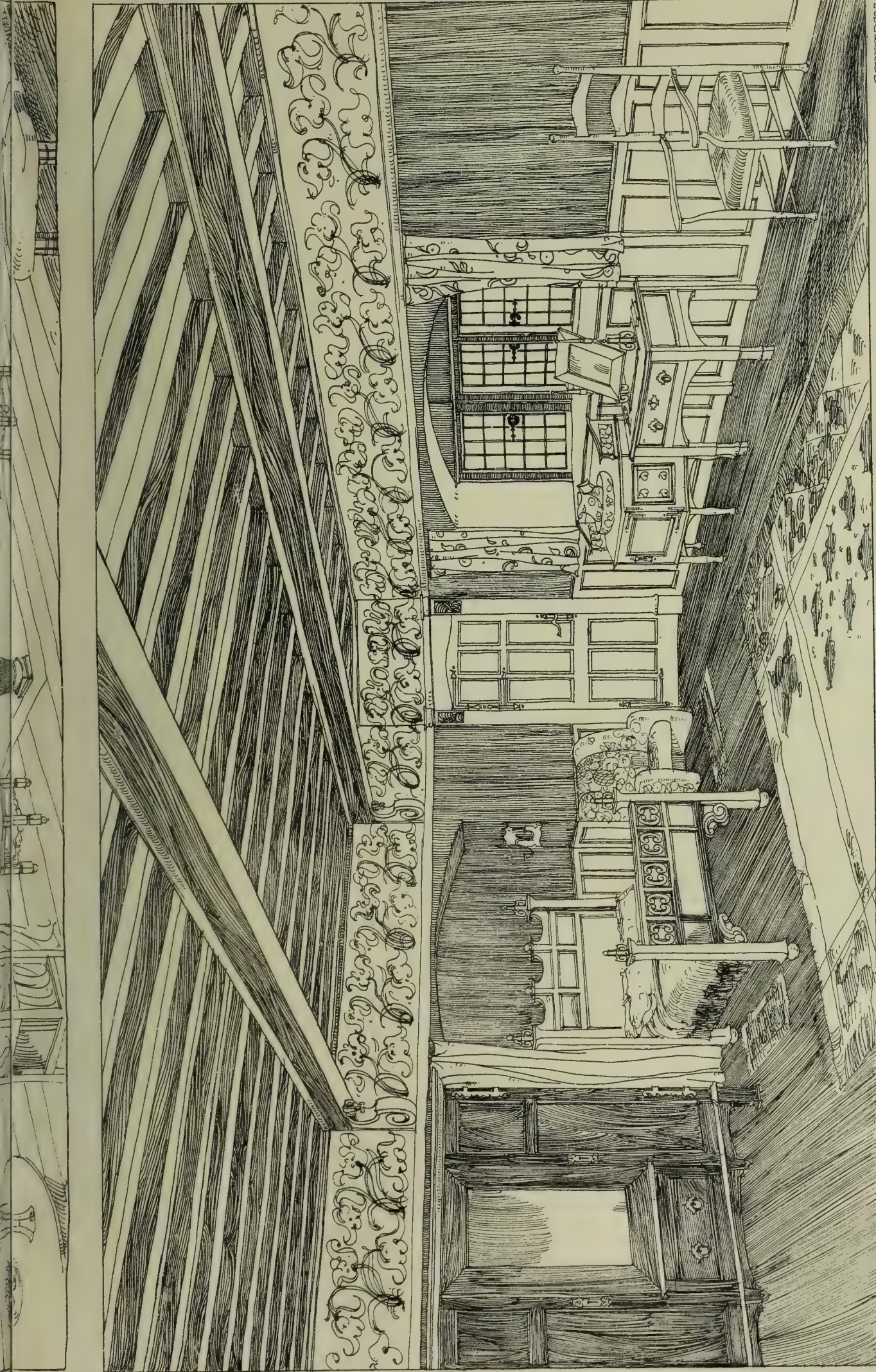

DESIGN FOR A SIMPLE BEDROOM

GEORGE DEB

Photo: Lithographed & Printed by James Alkerman, 6, Queen Square, W.C.



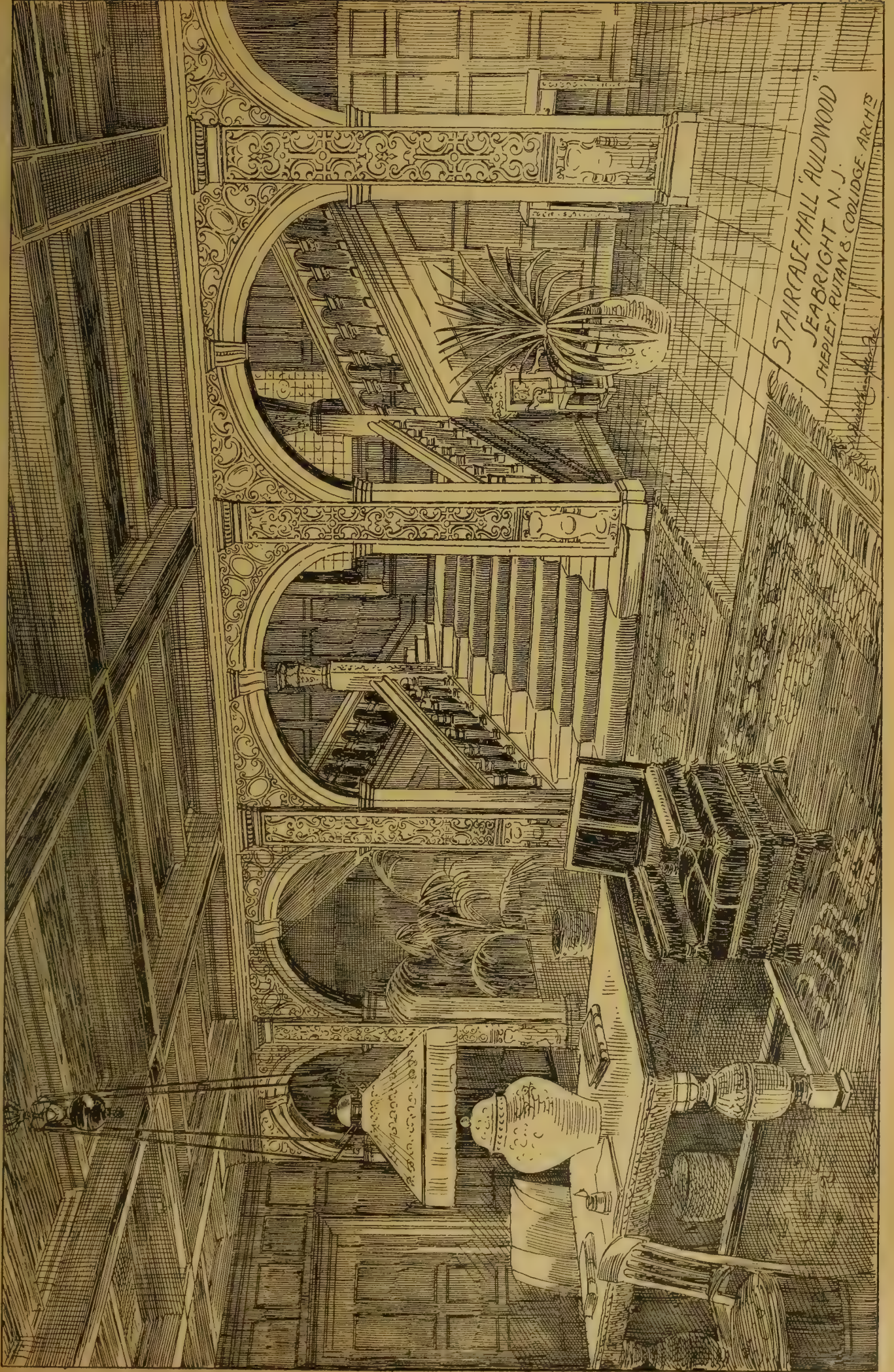

STAIRCASE HALL "AULDWOOD"  
SEABRIGHT, N. J.  
SHERLEY, RUTAN & COOLIDGE, ARCHTS.

## Building Intelligence.

**KENNINGTON, S.E.**—A new theatre is being built in Kennington Park-road, from designs by Mr. W. R. G. Sprague. It will have frontages of about 80ft. to Kennington Park-road, 150ft. to South-place, and 90ft. to De Laune-street. The main frontages will be executed in white Portland stone. The elevations are of Italian Renaissance character. The more expensive parts of the house will be entered from Kennington-road by a few broad steps running the entire length of the 50ft.-wide colonnade into a vestibule, and thence to the grand crushroom, which will be 42ft. by 22ft. The walls will be of an Italian marble, and recessed marble columns will be employed. From this crushroom one ascends a marble staircase 27ft. wide, branching off on each side to the dress-circle, with a separate entry to each side of the stalls. Above the main crushroom will be a ladies' foyer and the grand saloon. Throughout the interior the decoration will be French Renaissance in style, with a free introduction of paintings on ceilings and panellings, whilst the draperings and colourings throughout will be of soft tints, with a free use of gold. The auditorium will have a depth of 70ft. and a width of 60ft., and will be constructed on the two-tier system. The electric light will be employed. Exceptionally large saloons are adjacent to each part of the theatre, the pit saloon having the walls entirely covered by fancy tiling. The gallery staircase and pit entries and exits are lined with white glazed bricks. The theatre throughout will be heated and ventilated on the plenum system. The stage will be fitted with a special double asbestos and steel fire-proof curtain, controllable by one man. The stage will be about 80ft. wide and 50ft. deep. Large scenery stores, painting-rooms, and property-rooms are included in the scheme. Mr. Sprague hopes to have the theatre ready in November.

**LONDON COUNTY COUNCIL.**—At Tuesday's meeting an animated discussion took place on a recommendation of the General Purposes Committee that the extreme end of the Victoria Embankment wall, by the corner of Westminster Bridge, be approved as a suitable site for the Boadicea statuary group, by the late Thomas Thornycroft. Eventually the recommendation was agreed to by 78 to 36 votes, a proposal to defer consideration of the recommendation for three weeks, and to take the opinion of the Presidents of the Academy and the Institute of British Architects and the First Commissioner of Works being rejected. It was referred to the Improvements Committee to bring up a scheme for the embankment of the Thames from the Victoria Tower-garden to Lambeth Bridge. It was referred to the Technical Education Board to consider the suitability of the Crystal Palace as a centre of technical instruction, and to ascertain the terms on which certain parts of the building and grounds could be acquired for such a purpose.

**MANCHESTER.**—The Owens College buildings, Oxford-street, will receive in the course of the next eighteen months an addition by the erection of the new Whitworth Hall, for which preparations are now in a forward state. The hall, standing at the intersection of Burlington-street and Oxford-street, will complete the college quadrangle, and will form a connecting link between the museum and the Christie Library. Messrs. A. Waterhouse and Son, the architects of the college, in preparing plans for the new edifice on a scale of dignity worthy the importance of the site, have adopted a modification of the style employed by them in the museum. Constructed of Minera stone, the eastern side of the hall, fronting Oxford-street, will rise to a height of 50ft. It will be pierced by a double row of windows, of which the lower will be somewhat plain in character; while the upper tier will consist of four large cusp-headed, transomed, two-light windows. The principal public entrance to the building from Oxford-street will be emphasised by two small pinnacled turrets rising to a considerable height, while the gabling over the doorway will contain lancet windows. Immediately beyond this feature will rise, at the south-eastern corner of the building, a turret, which, with its fellow at the opposite angle, will flank the great traceried Perpendicular window in the south front. Both towers will contain staircases, and the westernmost of the pair will mark the entrance to the hall from Burlington-street. Within the building, on the ground floor, will be

arranged a number of small apartments for examination. Above them, along the entire length of the building, will be the great hall, which will measure just over 120ft. by 50ft., its height up to the roof-plate being 35ft., and to the visible apex 56ft. 6in. This open-timbered roof will represent a modification of the hammer-beam treatment. The organ is to be placed in the north gallery. At the other end of the building there will be not a gallery proper, but tiers of seats rising one above the other from the floor of the hall. Seats will be found for 977 persons, including the orchestra. For heating purposes a system of warm air, avoiding the use of radiators, will be adopted. The total cost is estimated at about £42,000.

**METROPOLITAN ASYLUMS BOARD.**—At Saturday's meeting of this board the South-Western Hospital Committee presented a report prepared by Mr. T. W. Aldwinckle in regard to the accounts for alterations and additions at the South-Western Hospital. The amount of the contract, as sealed, was £24,300, and the total accounts amounted to £28,857 16s. 6d.—a difference of £4,557 16s. 6d. The report was referred to the finance committee for consideration and report. Mr. Brass moved a resolution to the effect that the question of the expenditure on the Brook Hospital be referred to the general purposes committee, with directions to instruct a solicitor to take the opinion of counsel as to the liability of the architect, Mr. T. W. Aldwinckle, to refund the managers all or any portion of the cost of the extra works or claims ordered or allowed by him on his own responsibility. Ultimately an amendment by Mr. E. White was accepted and agreed to, in favour of obtaining an opinion on the general question of the personal liability of architects for work ordered by them without authority.

**THE PASSMORE EDWARDS INSTITUTIONS.**—Sir John Lubbock, M.P., opened the public library, Hoxton, on Wednesday afternoon. This has been built by Mr. George Hooper, from plans by Mr. Charles Bell, F.R.I.B.A. Mrs. Creighton, accompanied by the Bishop of London, will open the hospital and nurses' home, Acton, at 4 o'clock on May 5. This building has been erected from plans by Mr. H. T. Hare, F.R.I.B.A., whose design, selected in competition, was given in our issue of Dec. 13, 1895. On May 12 the Duchess of Marlborough will open the home for epileptic men, the Victoria House, at Chalfont, Buckinghamshire, and immediately afterwards the Duke of Marlborough will lay the foundation stone of the home for epileptic boys, while Mrs. Passmore Edwards will perform a similar ceremony for the home for epileptic girls. These three homes, which are being built from plans by Mr. Maurice B. Adams, F.R.I.B.A., were illustrated in our issue of June 25, 1897. A little later in May Sir H. H. Fowler, M.P., will lay at Clacton-on-Sea the foundation-stone of a holiday home for children, with 80 beds, to be maintained and administered by the Sunday School Union. Of the latter building Mr. Charles Bell is the architect.

### CHIPS.

The new baths which the Leeds Corporation have erected in Holbeck-lane, Holbeck, are to be opened to-morrow (Saturday) by the chairman of the Leeds Baths Committee.

Owing to the opposition raised by the Ipswich Corporation, the Great Eastern Railway Company have withdrawn from their General Powers Bill, now before the House of Commons, the section asking for powers to construct a dam over the River Orwell, just below Stoke Bridge, Ipswich.

A Local Government Board inquiry was held on March 24, before Colonel A. J. Hepper (inspector) in the Municipal Offices, Liverpool, touching the applications by the corporation for powers to borrow £2,000 and £600 for the purpose of recreation grounds. Mr. Pickmere, deputy town clerk, and Mr. Shelmerdine, surveyor, represented the corporation.

The excavations of the Greek Archaeological Society at Thebes, in Boetia, have brought to light a necropolis of the Mycenaean age, the tombs of which are similar to the rock-tombs of Argolis and Attica. The richest amongst them contained personal ornaments in gold and bronze of the Mycenaean type, and objects of Egyptian porcelain.

The Mersey Docks Board have decided to increase the salaries of Mr. W. Brodie, head of the drawing and general offices, from £450 to £500 per annum; and of Mr. W. L. Wallace, surveyor and measurer-up of all work done under contract, from £330 to £350.

### PROFESSIONAL AND TRADE SOCIETIES.

**EDINBURGH ARCHITECTURAL ASSOCIATION.**—The members of this association visited, on Saturday afternoon, the Scottish Museum of Science and Art, Edinburgh, by the kind permission of Sir R. Murdoch Smith. The curator, Mr. D. J. Vallance, who conducted the party, gave a general description of the building, the dates and methods of its construction, the precautions taken against fire, the heating arrangements, and the workshops. Explanatory remarks were also given of the arrangement of the collections, and attention was drawn to the more important specimens. At the conclusion of the visit, Mr. Thomas Ross (president) proposed a vote of thanks to Mr. Vallance.

**MANCHESTER AND SALFORD BUILDING TRADES ASSOCIATION.**—The annual general meeting of this association was held at the Albion Hotel, Piccadilly, on Monday, the 21st ult. Mr. George Macfarlane, vice-president, in the absence of Councillor W. Holland, J.P., president, occupied the chair. After reading the annual report, which was adopted, the president, vice-president, treasurer, and council were unanimously re-elected. The chairman, in his address, stated that the previous week the final arrangements had been made and officers elected, forming a Federation of Building Trades Employers for Lancashire and Cheshire. This combination of building trades employers embraced, along with Manchester and Liverpool, twenty-four of the largest towns in Lancashire, and also some of the towns in Cheshire. The purpose of the Federation is to unite all the local associations connected with the building trade throughout Lancashire and Cheshire, and form builders' associations in towns and districts where they do not already exist. This plan of federating local associations with a county federation is part of a national scheme whereby all England and Wales is first apportioned or divided into county districts, then into national association centres. A map has been prepared, showing fourteen county divisions—these, again, are combined into five national centres—the National Association of Master Builders of Great Britain, being the head, uniting all. Thus every town and every group of villages would have a Masters' Association dealing with matters immediately connected with their own locality, the county division dealing with wider and more important issues, while the National Centre would focus the power of all the constituent associations. By this scheme a truly national association will be formed that will have strength and weight to deal with any matters affecting the building trades. In Manchester, they had difficulties before them in two of the building trades. The carpenters and joiners have given notice for alterations to their working rules, which, if adopted, would seriously affect employers. They trust, however, that some mutual concessions will overcome the present difference. The stonemasons have also sent in notice for another 1d. per hour, and rather drastic alterations to their working rules. If such stringent working rules as the masons now wish to enforce were adopted by all the other trades in the country, England would, in a few years, become a third-rate power, and such a thing as free trade would be unknown. The limitation of apprentices question is a very serious one, producing a marked scarcity of workmen in the trades affected. Mr. Walter Marshall, stonemason; Mr. W. Higson, jun., plasterer and painter; Mr. Henry Matthews, builder; Mr. Frank Williams, plumber; Mr. Ames Mason, plasterer; and Mr. J. Daniels, builder, spoke upon the importance of getting the various members of each trade to join their several associations. The necessity of having a Builders' Institute or Building Trade Exchange was raised by some of the members, and the secretary, Mr. Fred Scott, was asked to communicate with those towns who had already formed such an institution for information as to their constitution and working.

A Dominican church is about to be erected at Charlestown, near Pendleton, from plans by Messrs. Sinnott and Powell, of Manchester and Liverpool. The building will be Gothic in character, and will be dedicated to St. Sebastian the Martyr.

An important meeting was held at the Stratford Room, Grand Hotel, Birmingham, on Wednesday week, attended by representatives of the building trade in the Midland Counties. The gathering was convened for the purpose of forming a Masters' Federation, and was well attended.

**TO CORRESPONDENTS.**

[We do not hold ourselves responsible for the opinions of our correspondents. All communications should be drawn up as briefly as possible, as there are many claimants upon the space allotted to correspondents.]

It is particularly requested that all drawings and all communications respecting illustrations or literary matter should be addressed to the EDITOR of the BUILDING NEWS, 332, Strand, W.C., and not to members of the staff by name. Delay is not unfrequently otherwise caused. All drawings and other communications are sent at contributors' risks, and the Editor will not undertake to pay for, or be liable for, unsought contributions.

Cheques and Post-office Orders to be made payable to THE STRAND NEWSPAPER COMPANY, LIMITED.

**TERMS OF SUBSCRIPTION.**

One Pound per annum (post free) for any part of the United Kingdom; for Canada, Nova Scotia, and the United States, £1 6s. 0d. (or 6dols. 30c. gold). To France or Belgium, £1 6s. 0d. (or 33fr. 30c.) To India, £1 6s. 0d. To any of the Australian Colonies or New Zealand, to the Cape, the West Indies, or Natal, £1 6s. 0d.

**ADVERTISEMENT CHARGES.**

The charge for Competition and Contract Advertisements, Public Companies, and all official advertisements is 1s. per line of Eight words, the first line counting as two, the minimum charge being 5s. for four lines.

The charge for Auctions, Land Sales, and Miscellaneous and Trade Advertisements (except Situation advertisements) is 6d. per line of Eight words (the first line counting as two), the minimum charge being 4s. 6d. for 40 words. Special terms for series of more than six insertions can be ascertained on application to the Publisher.

Front-page Advertisements 2s. per line, and Paragraph Advertisements 1s. per line. No Front-page or Paragraph Advertisement inserted for less than 5s.

Advertisements for the current week must reach the office not later than 3 p.m. on Thursday. Front-page Advertisements and alterations in serial advertisements must reach the office by Tuesday morning to secure insertion.

**SITUATIONS.**

The charge for advertisements for "Situations Vacant" or "Situations Wanted" is ONE SHILLING for TWENTY-FOUR WORDS, and Sixpence for every eight words after. All Situation Advertisements must be prepaid.

**NOTICE.**

Bound copies of Vol. LXXIII. are now ready, and should be ordered early (price Twelve Shillings each), as only a limited number are done up. A few bound volumes of Vols. XXXIX., XL., XLI., XLVI., XLIX., LI., LIII., LVIII., LX., LXI., LXII., LXIII., LXIV., LXV., LXVI., LXVII., LXVIII., LXIX., LXX., LXXI., LXXII. may still be had, price Twelve Shillings; all the other bound volumes are out of print. Most of the back numbers of former volumes are, however, to be had singly. Subscribers requiring any back numbers to complete volume just ended should order at once, as many of them soon run out of print.

**GOOD FRIDAY.**

NEXT week the BUILDING NEWS will be published on THURSDAY. All Advertisements for the next issue, therefore, must reach the Office by THREE p.m. on WEDNESDAY NEXT, instead of on Thursday, as usual.

J. D. (Better try silicate cotton. See recent replies in "Intercommunication.")

RECEIVED.—T. K. A.—H. C.—O. M. W. J.—T. W. E.—M. G. and Co.—F. L. C.—M. M.

**Correspondence.**

**THE ROYAL INSTITUTE OF BRITISH ARCHITECTS.**

To the Editor of the BUILDING NEWS.

SIR,—Yours is the only journal in which members can express their disapproval of anything done by that august body the Council.

I want to know why Mr. Aitchison should be asked to serve another year, when there are plenty of good men who should have a chance? To re-elect the president is a confession of weakness in any large society. It is not as if the present president had designed a vast number of buildings, and made a great name; in fact, when you are asked by any member of the public to name some great building of great beauty and excellence, you find it difficult to answer, so have to state that he is a very scholarly, genial man.

Then why should arch tects over forty years of age be unable to compete for the prize essays, as it is in middle life that men generally can, from their experience, find something interesting and instructive to write about?

Finally, does the present system of electing Fellows quite give satisfaction, as the Council set aside all the benefit of well-known sponsors, and judge the candidate by the drawings submitted? Thus, a man who has been trained as an architect, but through lack of friends has carried out

very little work, is rejected; while the exhibitor's clerk or land agent, who has carried out a number of important jobs by the aid of able assistants, is admitted, although probably he never made a drawing with his own hand in his life.

The poor attendance at the ordinary meetings should have the immediate consideration of the Council.—I am, &c.,

ASSOCIATE.

**CHIPS.**

The Archaeological Museum of Berlin has received permission from the Sultan to make excavations at Miletus. The work will begin next autumn, under the direction of Dr. Wiegand.

Premises in Liverpool-street, Southampton, are being pulled down to make way for a new theatre, to be built for Messrs. Morell and Mouillot. The theatre will have a tower 82ft. in height, and will be isolated on three sides. Accommodation will be provided for 1,800 people. Messrs. Jenkins and Son, of Southampton and Bournemouth, are the contractors.

A joint deputation of the County Councils Association, the Association of Municipal Corporations, and the Association of Technical Institutions waited upon Sir John Gorst at the Privy Council on Wednesday week, in order to lay before him the views of the associations in regard to the recent decision of the Government abolishing building grants from Imperial funds to schools and institutions under the Science and Art Department. The speakers especially dwell on the inconvenience caused by the withdrawal of the grants without previous notice. Sir John Gorst promised to bring the views of the deputation before the president of the Council.

As a memorial to her uncle, the Earl of Shaftesbury, Miss Ashley, of Stratton Manor, Dorchester, has presented to the Dorchester Union Workhouse a new chapel for the use of the inmates.

The formal ceremony of opening the new annexe of the Central London Ophthalmic Hospital, Gray's Inn-road, was performed on Friday by the Lady Mayoress. The hospital was established in 1844, and until 1882 it occupied only one house at the corner of Calthorpe-street. Then it acquired the next house, and now it has absorbed the two adjoining. The last extension, which has cost £1,700, has raised the accommodation from 12 to 28 beds. The committee have in view the demolition of the whole block, and the erection of a modern hospital upon the site as soon as the funds will permit.

A new county school for Flintshire has been built at Penymaen, near Hollywell, and will be opened by the Duchess of Westminster about a week hence. The building is carried out in red Ruabon brick in the Domestic Tudor style. The contractor was Mr. Matthew Rogers Flint, and the architects were Messrs. Bellis and Grierson, Bangor.

The whole of the block of buildings of the up-platform refreshment-rooms at Swindon Station, on the Great Western Railway, were burnt out on Saturday morning.

The death has occurred at the Johnson Hospital, Spalding, of Mr. Edward John Tatam, at the age of 53 years. The deceased was a civil engineer, and was a well-known authority on drainage matters in the Fen districts.

The Railway Department of the Dominion Government has just presented its annual report, which shows that the last fiscal year ended (on July 1, 1897) with 16,687 miles of railway completed and 16,550 in operation in Canada, the former total showing an increase of 300 for the year.

An inquiry is being made by the committee appointed by the Home Secretary into the extent to which water gas and other gases containing a large proportion of carbon monoxide are being manufactured and used for heating, lighting, and other purposes, and the dangers which may attend such manufacture and use. The committee is composed of Lord Belper, chairman; Mr. H. H. Cunynghame, Assistant Under-Secretary of State for the Home Department; Dr. Marsons, Local Government Board; Dr. Haldane, and Professor Ramsay, with Mr. J. Pedder, of the Home Office, as secretary.

Col. Waring, Street Commissioner for the City of New York, is given as authority for the statement that ashes mixed with lime make a mortar superior in point of lightness and strength to mortar composed of lime and sand. By the substitution of ashes for sand the cost of the mortar would be reduced by more than one-third.

Mr. R. E. Paget, vestry clerk of Clerkenwell, has received a letter from the secretary of the Metropolitan Railway Company, informing the vestry that his directors had under consideration the question of providing a station at Rosebery-avenue, between King's-cross Station on the one hand and Farringdon-road Station on the other.

**Intercommunication.**

**QUESTIONS.**

[11923.]—**Note on Crane Scaffolding Calculations.**—(1) It seems doubtful whether the structures for cranes, if composed of three legs or towers bound together by diagonal braces and also by lattice frames connecting their tops, should be considered as one triangular frame with sides of 60ft. long or thereby; or as three independent towers, each from 10ft. to 18ft. square; but it is considered reasonable that each tower should be able to stand alone. (2) The horizontal wind pressure on vertical surfaces is stated to rise to 50lb. per super. foot (see Rivington, part IV, table 14, p. 339); but this pressure is called by authorities a "violent hurricane" (Hurst, p. 140). On this datum the whole question rests, and Hurst's table above quoted rises from a "fresh breeze" of 15 miles an hour giving a pressure of 1½lb. per foot, to a "storm" of 50 miles an hour giving 12½lb., and a "violent hurricane" of 100 miles an hour giving 50lb. (3) The wind is the main force to be considered as opposed to the stability of the tower, for in a height of 6ft. and a dimension of say 10ft. by 10ft. this supposed possible wind force, if square on the side of the tower, would have a moment of 6ft. by 1ft. by 50lb. by 32ft. (height of centre of gravity), which equals 457 tons on a solid structure, or 45.7 tons on one nine-tenths hollow on the side. This very far exceeds any weight or strain to be otherwise brought to bear, for the boiler, crane, and load would not generally exceed about 15 tons, standing on all three towers. (4) Suppose the tower to be of solid wood at 32lb. weight per cubic foot, then 6ft. by 10ft. by 10ft. by 32lb. by 5ft. (distance of vertical line of gravity from fulcrum) equals 457 tons—i.e., the tower would be in equilibrium, but have no factor of safety during a "violent hurricane," giving a wind-pressure of 50lb. per square foot. (5) If, again, two-thirds of this supposed mass were hollow, and the side acted on by the wind contained √ one-third or √ the solid contents, then the material would have to be three times the above weight, or 96lb. per cubic foot, and could not, therefore, be of wood if only 10ft. by 10ft. = 100sq. ft.; but it might be so if √300, or, say, 18ft. by 18ft. (6) Consider, therefore, a tower 18ft. by 18ft. framed of four legs of wood at 32lb. per cubic foot, and having each leg x<sup>2</sup> in scantling, then—  
Wind-pressure = 6ft. × 2x × 32ft. × 50lb. = 251 tons  
Weight moment = 6ft. × 4x<sup>2</sup> × 32ft. × 9ft. dist.  
= 9 × 28 tons—(equal.)

When x = 2ft. 9in.—i.e., the frame would be in equilibrium if on four wooden legs each 2ft. 9in. square, in a violent hurricane. (7) The lattice-framing has not been considered; but it is supposed above that the 6ft. long legs are sufficiently stiffened thereby to be kept straight. The lattice is mainly useful for this end, and it is suggested that it would probably hold the wind sufficiently to counteract much of its strength. The bending stress of a load of 15 tons on top of three towers, each weighing 28 tons, may be safely neglected; but the additional weight of five tons on each tower, and the substitution of wood, which weighs 36lb. per cubic foot, would reduce the requisite scantling to 2ft. 7in. by 2ft. 7in., or 96lb. sq. in., to be in equilibrium in a violent hurricane. So proportionately per square inch of section, according to Hurst, a stiff leg of 7½in. by 7½in. would cause equilibrium in a "brisk wind" of 25 miles per hour, giving a pressure of 3½lb. per super. foot.—NISI DOMINUS FRUSTRA.

[11924.]—**Terracotta Work.**—Will some practical reader enlighten me as to the best size of blocks, where the best terracotta for architectural purposes can be obtained, how the pieces are to be set, and any point to insure good work—what thickness of joint, and what mortar?—NOTA BENE.

[11925.]—**Gauged Work.**—Is there any work treating on ornamental brickwork, gauged or rubbed, and the name of it? I shall be glad with a reply.—W. H. H.

[11926.]—**Size of Chimney Stack.**—Will any practical reader tell me the best size for flues in the stack for a three-story building? A flue 14 by 9in. is awkward. Can these be made square at the top, and which is the best way to gather the brickwork together?—A STUDENT.

[11927.]—**Extra Commission.**—A. employs an architect to carry out certain works. The architect, in the usual course, employs a quantity surveyor. The contract is let, and the work completed. The contractor complains that the quantities are in certain items short, and submits an account of what he considers to be the correct measurements. It then becomes necessary that the work should be measured up. Is the architect entitled to any further commission for satisfying himself and his client that the amount claimed is really due before granting a certificate, or can he refuse to do so, and merely give a certificate on the finding of an independent surveyor? If the latter, who is liable to the surveyor for his charges? Or, briefly, is an architect entitled to extra commission for measuring up work for the purpose of granting certificates on account, and on completion for the total amount expended? Perhaps Mr. Lovegrove or Mr. Fletcher would be good enough to answer this.—SIC.

[11928.]—**Workhouses.**—Will any of your readers with experience in the planning or carrying out of the above kindly inform me what would be a reasonable price, per inmate, to allow for a workhouse to accommodate, say, 1,200 to 1,400, exclusive of site?—OMEGA.

**REPLIES.**

[11922.]—**Cleaning Headstones.**—I should think the application of acid to stone or marble would injure the surface. I should rather wash it well with one of the prepared soaps, or rub it with stone.—G.

The corporation of Canterbury are about to build a city lunatic asylum on the Stone House Estate, Littlebourne-road. Mr. W. J. Jennings, of Canterbury, is the architect, and buildings, two stories in height, will be built for 250 patients behind the existing premises, which will be utilised for administrative purposes.

## LEGAL INTELLIGENCE.

**FRANCIS MORTON AND Co., LIMITED.**—In the Court of Chancery of Lancashire, at St. George's Hall, Liverpool, on Monday, Vice-Chancellor Hall presiding, Mr. John Rutherford said that in regard to the case of "Francis Morton and Co., Limited," he appeared in support of a petition by a creditor for the winding up of the company, a voluntary winding-up resolution having been adopted in January, 1897. However, nothing practical had been done, and the question was whether or not an end should be put to the matter. The petitioning creditor claimed £1,117 13s. 10d. and costs of judgment. Mr. Rotch, on behalf of the company; Mr. Durand, for the second debenture holders; and Mr. Hughes, for creditors representing £16,000 out of a total liability of unsecured debts of the £23,000, opposed the application. The preliminaries necessary to the motion had not taken place before the Registrar. The Vice-Chancellor said he could make no order, especially in face of the opposition offered by Mr. Hughes. He would, however, give leave to amend the petition by asking, in the alternative, for a previous order, and meanwhile the petitioner could go before the Registrar, and put everything in order. Answering the Vice-Chancellor, Mr. Hughes explained that negotiations were proceeding for the sale of the concern, and unless it were disposed of at a good price, there would be nothing left for the creditors after satisfying the debenture holders. The Vice-Chancellor said he would not allow one man to wreck the company, if there were any chance of keeping it afloat; but he could not at present dismiss the petition.

**A QUESTION OF CUSTOM.**—At Marylebone County-court, on Tuesday, before his Honour Judge Stonor, Messrs. H. E. Foster and Cranfield, surveyors, claimed £44 14s. 6d. from Mr. Wm. Dean, a retired licensed victualler, at present residing at Shooter's Hill, Kent, but formerly of Malvern Tavern, Notting Hill, W. Mr. G. M. Cohen and Mr. E. J. Green appeared for the plaintiffs, and Mr. D. M. Kerly for the defendant. Mr. Green stated that in May, 1870, a Mr. Crewse became the freeholder of Malvern Tavern, and shortly afterwards granted a lease to another man, under whom the defendant became a lessee. About 1892 the defendant proposed to make certain alterations in the property, and this coming to the knowledge of Mr. Crewse, he wrote to the plaintiffs instructing them to write to the defendant asking for specification and plans. The plaintiffs, acting in the interests of the freeholder, were continually upon the property, and the amount now claimed was in respect of such works for which the defendant was liable. The Judge: Had you any authority for it? I do not see that the defendant is liable. Mr. Green: I shall show that it is the usual custom. The ground landlord was getting no benefit out of the alterations. The Judge: I shall ask for some authority, or I shall rule to the contrary. Mr. H. E. Foster deposed that he had previously been instructed in similar cases, and had always been paid by the lessee. Mr. Kerly: There surely cannot be a question of custom here. In answer to Mr. Kerly, witness admitted that the plans were made for the landlord's guidance and as a record of what had been done. He had regarded Mr. Crewse from first to last as his employer in the transaction, with the exception of some work done in regard to ancient lights. The whole bill had been made out in the name of Mr. Crewse, and sent in to his solicitors. Application had been made to the defendant for payment, but refused, and the present action was instituted before it became statute barred.—Mr. Wm. L. Cranfield deposed that defendant personally gave him instructions with regard to the light. In October, 1892, the defendant told him not to proceed further with the matter; but witness worked at it until December of that year. Part of the amount charged was for the preparation of plans which it was found impossible to get from the defendant's surveyor.—Mr. Wm. Dean, the defendant, denied that he had ever instructed the plaintiffs to do any work for him. They were engaged on behalf of the ground landlord. In regard to the ancient lights, he particularly asked the plaintiffs not to go to any expense in the matter. On a previous occasion, when in occupation of The Warrior, Deptford, he had to pay the landlord's surveyor a fee of 2 guineas on the occasion of some alterations being effected.—His Honour said he believed the plans were furnished, and the work in connection with the lights done, at the request of the defendant, and he gave a verdict for the plaintiffs in respect of the fee of 10 guineas, with costs. He refused to accept the evidence as to custom.

The church of St. Thomas à Becket, Bovey Tracey, has just received a new Litany desk, a memorial to the late Mrs. Southey. It is 15th-century Gothic in style, blending with the surroundings, and is wrought in English oak. It is from the studios of Messrs. Harry Hems and Sons, church workers, of Exeter.

## PARLIAMENTARY NOTES.

**THE NATIONAL GALLERY.**—Dr. Farquharson asked the Under Secretary for War, on Monday, when the long-promised removal of St. George's Barracks would take place; and whether in the mean time any steps were being taken to lessen the risk from fire by the close proximity of the canteen to the Turner Room of the National Gallery. Mr. Brodrick: The partial evacuation of St. George's Barracks will take place as the barracks at Millbank are ready, and a portion of the building will then be handed over to the Office of Works. It is unlikely that this can take place before the end of next year. The canteen is at some distance from the National Gallery. There will be a space of 15ft. between the National Gallery and the barracks when the alterations have taken place.

**PUBLIC BUILDINGS BILL.**—Mr. Akers-Douglas formally moved, on Monday, the second reading of the Public Buildings Expenses Bill, providing for the erection of War Office, Admiralty, Science and Art, and other public buildings in London, at an estimated cost of £2,500,000. Mr. Dillon moved, as an amendment, that the Bill be read a second time that day six months, he disapproving of the general financial character of the Bill. Sir F. Powell, as chairman of the Museums Committee, strongly supported the measure. Mr. Bryce called attention to the desirability of making provision in these new blocks of public buildings for a comprehensive library which should serve the needs of all the great departments, and which also, to some extent, might be made to serve the needs of the public. Nearly all their great public departments had got a more or less insufficient library. In Paris the Ministry of Justice had such a library as he had described, and it was found to be of great service by the public as well as by the department. The Congress at Washington had a similar library, but very much larger—corresponding, in fact, to the British Museum library. Mr. Herbert Gladstone supported the Bill as a practical and comprehensive scheme, on which he congratulated the First Commissioner of Works. He asked the right hon. gentleman to reconsider his proposal to intrust the design of the new buildings to an outside architect, with the view of seeing whether he could not employ Sir John Taylor to design the whole building, both outside and inside. If anybody wished to see specimens of Sir John Taylor's work, there were the new police-court in Bow-street, the new Bankruptcy Court buildings in Carey-street, and the last addition to the Record Office in Chancery-lane. Each of these buildings was admirably designed for its purpose, with an excellent external appearance. The new addition to the Record Office was one of the best and most handsome buildings erected in London in the last fifty years. Sir John Taylor would design buildings for the new front of Parliament-street which would be in harmony with the great surroundings, and he knew better than anybody the mistakes made by architects in previous buildings, and would not err in the same path. He urged that the new offices in Whitehall should not align with the Home Office, but should, if possible, be recessed a little. This would be better architecturally, and would give increased width to Parliament-street, which was desirable. Had any decision been come to as to the location of the police-station in King-street, and would the Civil Service Commissioners be moved from their present position? At South Kensington, he understood, the Science and Art Department would be housed on the east side of Exhibition-road; thus a considerable space would be set free. What would be the extent, and what was proposed to be done with it? Mr. Akers Douglas, replying on the discussion, said special attention had been called to the widening of Parliament-street. Three proposals were put before the committee last year. That of the Government was to make the width of Parliament-street the same as that of Whitehall; that of his right hon. friend opposite was to leave the whole space open; and that of the Royal Institute of British Architects was to diverge slightly from a parallel line so as to give increased effect to the existing Home Office. The committee came to the conclusion that they should maintain the parallel line. If they adopted the proposal put forward by his right hon. friend, and decided that Parliament-street was to be finished off by an obtuse angle, the architectural effect would be bad, and it would cost £108,500 more. The scheme put forward by the Royal Institute of British Architects would cost about £20,000 more than that of the Government. His attitude with regard to this question would be guided by the advice of the architect who carried out the building. They would not necessarily follow the exact line of the Home Office, and he should be prepared to recommend a sum slightly in excess of the estimate if it should be found desirable to do so for architectural purposes. As to the architect, his right hon. friend asked him to press Sir John Taylor to accept the appointment. No man had a higher opinion of Sir John Taylor's ability than he had. But he was afraid he would not be able to persuade Sir John to undertake at his time of life,

and after his long service, so onerous a duty as that. He had been fortunate enough, however, to secure his services (which would be lost to the State this year) for another three years, in order to have the benefit of his assistance as assessor in carrying out the plans of these buildings, and he would have a very large discretion in their arrangement. The Government were also fortunate in securing as another assessor Mr. Aitchison, R.A., president of the Institute of British Architects. It had been arranged that the police-station in King-street should be moved to the building now occupied by the Civil Service Commission, Cannon-row. The Civil Service Commission would be removed to premises which had already been taken for them in Victoria-street. As to the scheme for the rearrangement of the buildings at South Kensington, he thought he had succeeded in finding a scheme by which the whole of the buildings required for science and art would be housed on the east side of Exhibition-road. When the committee inquired into this subject last year they came to the conclusion that the official residences were a source of danger from fire to the collections of art. When the buildings which the committee had condemned were taken down it was found that the Government had a very much larger space at their disposal than they had anticipated. They therefore decided to place the whole of the new buildings on the east side of the road, and in those buildings they would find accommodation for both the Science and Art Departments for many years to come. The existing buildings on the western side would still be retained. The right hon. member for Aberdeen had asked him whether they could find room for a comprehensive library for public departments, in which there should be a copy of every blue-book of this and of other countries. He was afraid the sites at their disposal would hardly provide for housing so large a collection. Ample space had been taken for the housing of the staff of the Education Department, and further room would be allowed for the expansion of the office. On a division, the second reading was carried by 202 votes to 19.—The Bill passed through Committee on Tuesday evening, when it gave rise to an animated discussion. It was again assailed by the Irish and Welsh members. Mr. Akers-Douglas and the Chancellor of the Exchequer gave conciliatory replies to both sections of members, and promised to consider any claims that might be brought before them. Mr. W. Reginald challenged a division on a reduction of the amount by a million, which he had moved, and was defeated by 294 to 31. The Bill at last got through the Committee stage without amendment, and on Wednesday it was read a third time, and will now go through its various stages in the House of Lords as speedily as possible.

**BARRACKS AT SHORNCLIFFE.**—Mr. Brodrick, in reply to Sir B. Edwards, said, on Friday: It is the intention of the Government to provide accommodation in permanent buildings at Shorncliffe for a cavalry regiment on the higher establishment, two battalions of infantry, three field batteries, a field company of engineers, and two companies of the Army Service Corps. The cavalry buildings are expected to be completed in 1899, and the others in 1900.

## CHIPS.

A translation of Benvenuto Cellini's treatises on goldsmith's work and sculpture, by Mr. C. R. Ashbee, is about to be published by the Guild of Handicraft, Essex House, Bow.

On Saturday, the formal opening took place of the new Market Hall, recently constructed in Dockray-street, in the borough of Colne, Lancs. The building has cost altogether, with the land, the town's market ground, and the fish market, about £9,000.

The foundation-stone of the new workhouse infirmary for the Islington Board of Guardians was laid at Highgate-hill on March 24. Mr. Smith is the architect, and Messrs. Kirk and Randall, of Woolwich, are the contractors. The cost will be about £250,000.

Two additional bells, to complete the peal of eight, are to be placed in the tower of St. Paul's Church, Walkden, together with a stained-glass window in the north aisle, during the coming summer, when the jubilee of the church will be celebrated.

A bronze statue of the Queen, intended for erection at Kingwilliamstown, South Africa, is now being cast at the foundry of Messrs. Hollingshead and Burton, Thames Ditton. It is a replica of the marble statue of her Majesty, executed in 1887 by the Queen's private sculptor, Mr. F. J. Williamson, of Esher, which now stands in the examination hall of the Royal College of Physicians on the Thames Embankment. A second statue, on similar lines, is also being executed in marble by the same artist at his studio at Esher, and will be erected at Londonderry; while a third copy, with modifications, is being prepared for reproduction in bronze, and is intended to be set up at Auckland, New Zealand.



## Our Office Table.

THE council of the Royal Institute of British Architects are determined to heap every honour in their bestowal upon their president. Not content with nominating Professor Aitchison as the recipient for the Royal Gold Medal for 1898, they have decided to recommend his election for a third year of office as president—a proposal which directly contravenes By-law 26, made under that Royal Charter which, when it suits their purposes, it is declared to be impossible to infringe in any particular. A private business meeting of members of the Institute is convened for Monday evening next at 8, to receive and consider the council's recommendation, and if this be adopted to take the first steps, under By-law 33, to suspend By-law 26, which declares that "No president who has filled the office for two successive years shall be again eligible for the presidency until the expiration of two years from the termination of his term of office." The recommendation will doubtless be agreed to *nem con.*, but it suggests a singular lack in the Institute of members qualified to occupy the chair.

A MEMORIAL signed by many of the leading architects, painters, and sculptors of the day appears in Wednesday's *Times*, expressing the anxiety of the writers that the great building schemes proposed by the Government should result in something that would worthily represent the architectural ability of the country. The signatories state that they have heard with dismay the utterances in Parliament of the First Commissioner of Works and the leader of the Opposition, whose disparaging criticism of Mr. Norman Shaw's New Scotland Yard seems to render it almost hopeless to expect anything from the present scheme but another architectural failure. The artists desire to place on record their admiration of Mr. Shaw's building, and their opinion that of the public buildings erected by Government in London during the present generation it is the one of which London may be most justly proud. The memorialists include Messrs. T. G. Jackson, R.A., L. Alma Tadema, R.A., Sir Arthur W. Blomfield, A.R.A., W. Butterfield, F.S.A., E. Onslow Ford, R.A., John Belcher, Thos. Brock, R.A., Philip Webb, John S. Sargent, R.A., W. R. Lethaby, Hamo Thornycroft, R.A., Walter Cave, Walter Crane, John F. Bentley, George Frampton, A.R.A., H. H. Armistead, R.A., J. C. Horsley, R.A., Frank Dicksee, R.A., Val. C. Prinsep, R.A., G. H. Boughton, R.A., Ernest Crofts, R.A., J. MacWhirter, R.A., Briton Riviere, R.A., Walter W. Oules, R.A., Ernest George, John Fulleylove, R.I., J. T. Micklethwaite, Philip Norman, Halsey Ricardo, and Basil Champneys.

REPAIRS and improvements have been in progress the last few months at Anne Hathaway's cottage at Shottery, near Stratford-on-Avon, and have just been completed. The trustees have not attempted a "restoration" in the modern acceptance of the term. All the window casements were in a dangerous state. The wood-work was rotten, and the old glass and leadwork were falling out. Several of the plaster panels between the timber-framing were on the point of collapse, and some of the main timbers were found to be decayed in places. The old windows and casements have been repaired. English oak frames and mullions have been put in, and the ancient glass has been put back in diamond-shaped leaded lights. The timbers have been renewed where necessary, sound oak, taken from ancient buildings in Stratford, being used. Two old windows hidden beneath the plaster were discovered and opened up, and oak panelling that has been removed at different periods has been restored to its original position. The beams have been scraped of the whitewash which had covered them for generations, and cleaned and oiled, and the several rooms made more interesting by disclosing once more various old characteristics of the building. The old-fashioned "dog-grate" of the living-room was found at the bottom of the old bacon cupboard, where it had remained about fifty years.

At the Society of Arts on Tuesday night, Sir Edward Maunde Thompson read a paper on "English Art in Illuminated Manuscripts." The lecturer observed that the knowledge of the history of art that was to be gathered from a study of the illuminated manuscripts of the Middle Ages would be more generally appreciated

if such manuscripts were more numerous than they are. Although they had survived in fairly large numbers, yet, in the ordinary nature of things, such portable relics, easily passing from hand to hand, must always have been liable to injury and loss. In our own day they were to be found in any numbers only in the national libraries or in the possession of a very few private collectors. The illuminated manuscript from its very shape had had an advantage which could scarcely be overrated for preserving the paintings and ornaments with which it was adorned—an advantage denied to the picture which hung upon the wall exposed to the light day by day and year by year. The earliest examples of illuminated manuscripts produced in England proved the existence of two distinct schools, differing essentially from one another, the one holding sway in the north, the other in the south, the one excelling in ornament, the other striving at a higher form of art and developing a remarkable power in figure-drawing. Both were imported, the Northern style being Celtic in its origin, and the Southern being introduced into the country without doubt by the Roman missionaries. The lecturer traced the development of the illuminated manuscript, referring especially to the Lindisfarne, Canterbury, and Winchester schools, fully describing some of the most interesting manuscripts now in existence. He observed that the political changes through which England had passed had surely left their mark upon the artistic productions, as they did upon the characters of the people; and as they moved from century to century they traced the hand of the Celt, the Roman, the Saxon, and the Norman as clearly in manuscripts as in the architecture of cathedrals and the remains of ancient sites. The wars with France and the convulsions of the War of the Roses seemed to have extinguished the last efforts of native artists, and henceforward the influence of the French style became so predominant that in the latter part of the 15th century the English art of illumination was practically dead.

THE comparative cost of gas and electricity as sources of light, heat, and power was the subject of a paper read before the Royal Scottish Society of Arts at George-street, Edinburgh, on Monday evening, by Mr. C. K. Grieve. Rather exaggerated claims had, the lecturer said, been made on behalf of electricity since the date of its introduction. Both systems had their proper sphere, and, apart from the question of cost, that was likely to continue. For the purposes of the lecture the hall was fitted up with incandescent gas lamps, and an inquiry into the cost of the two illuminants showed that lighting by electricity cost four times as much as lighting by these lamps. Heating by electricity was, he said, much more expensive than heating by gas. Comparing gas-engines with electric motors, it might be said that in regard to convenience they were equal, but the cost per horse-power was considerably greater for the electric motor than for the gas-engine. Bailie Mackenzie said that he had not heard that part of the paper which dealt with the question of light, but in regard to motive power his opinion was that for all practical purposes, if the cost of the electric current was reduced to 1½d. per Board of Trade unit, as he hoped it would be in Edinburgh, it would be quite as cheap as Edinburgh gas at 3s., or as it would shortly be, 3s. 2d. His conclusion was that electric light at 4½d. per unit was just about the same price as gas at 3s. per thousand feet, and it was admitted all over that electric light at 4d. was as cheap, if not cheaper, than gas at 3s.

A NEW volume of photographic illustrations has been issued by Messrs. Aldam Heaton and Co., of Bloomsbury-street, W.C., giving a large number of executed designs in stencils for wall and frieze decoration, a variety of glass patterns for quarry windows, as well as figure-work for houses and churches. There are also a lot of chimney-pieces and furniture designs, curtains, and some ceilings. Colour, in not a few of these productions, form their essential characteristic, and in monotone printing, of course, the colour is left to the imagination; but for form and detail these colotype prints are unexceptional, and there is no risk of misrepresentation by tricky draughtsmanship. As we are personally acquainted with many of the designs chosen for illustration, we can speak highly of their excellence and good taste. They are as refined in idea as they are commendable in execution—new, without vulgarity.

In connection with the great city improvement

made by the corporation of Edinburgh in the rebuilding of the North Bridge and the widening of North Bridge-street, an important sale took place on Wednesday of the areas on each side of North Bridge-street, recently acquired by the corporation. The whole of the west side of North Bridge-street, from the bridge to High-street, with a frontage of 350ft. and a depth of about 130ft., was exposed for sale in one lot at £120,000, and was purchased at that figure by the proprietors of the *Scotsman* newspaper. It is the intention of the purchasers to erect on the principal portion of the site, which faces Prince's-street, extensive offices for the accommodation of all departments of the *Scotsman*. A block on the east side of the street was sold to the Commercial Bank for £35,000, while two remaining blocks, on the same side, did not find a purchaser.

A PAMPHLET is being issued by the National Hardware Association, 1, Creed-lane, Ludgate Hill, entitled "Ironmongers and the Plumbers' Registration Bill," warning ironmongers that their interests are seriously threatened by the Bill now before Parliament. It is stated that the system of registration begun some time ago by the Plumbers' Company was the beginning of a scheme which may exclude ironmongers from plumbing work. While the present Bill is intended to strengthen the hands of plumbers in their demands, there is not, it is claimed, a single provision in it which will secure that better work is done. A number of amendments are suggested. Among them there are the following:—That members of the proposed general council which is to make by-laws shall include eight ironmongers, since the representation of master plumbers and operative plumbers is specially provided for; that firms as well as individuals shall be registered; and that every ironmonger who employs capable ironmongers shall be put on the "authorised list." But the best course, it is urged, would be to destroy the Bill altogether.

## CHIPS.

The partnership hitherto subsisting between W. Matthews and W. L. Lawrence, surveyors, Delahay-street, Westminster, under the style of Matthews and Lawrence, has been dissolved.

Mr. Robert H. Bicknell, L.G.B. inspector, has held an inquiry at Norwich into an application by the city council to borrow £13,500 for works of sewerage, and a sum not exceeding £4,900 for the purchase of premises for the extension and improvement of the provision market.

The Dean of Winchester has received an offer from Mr. Boyd, of Sillwood, Winchester, to defray the cost, amounting to over £200, of an addition to the recently reconstructed organ in the cathedral of the great 32ft. reed pedal stop.

The old irregular cricket pavilion at Kennington Oval is being replaced, at a cost of over £30,000, by a new structure. It is of red bricks, with Bath stone dressings, and has a frontage of 300ft. The building is to be finished early in May, in time for the opening match of the season. Messrs. Foster and Dicksee, of Rugby, are the contractors.

In the case of Samuel T. Harvey, of Queen Victoria-street, E.C., surveyor and builder, the bankrupt's discharge has been suspended for three weeks, ended March, 24, 1898.

An appeal is being made for £1,000 for the restoration of the ancient tower of St. John de Sepulchre at Norwich. It is situated in Ber-street, and, with one exception, rises to the highest point in the city, but is badly cracked from summit to base, and two of the five bells are broken.

The services rendered by Sir Thomas Roe to Derby were recognised on Wednesday evening by the presentation to him of his portrait, painted by Mr. J. F. Shannon, A.R.A. Sir Thomas asked the mayor to accept the portrait on behalf of the town.

Mr. C. T. Ritchie, M.P., visited Croydon on Wednesday, and performed the ceremony of opening some cottage homes, which have been erected by the board of guardians at a cost of £7,080, for the accommodation of pauper children of the union.

An extensive piece of ground on the West Hoe estate at Plymouth has been secured by a powerful syndicate as a site for a large new up-to-date hotel, with winter garden and opera-house. The ground has for some time been fenced in. The work of clearing and levelling the ground has been begun, and the erection of the buildings will be commenced forthwith. The work has been intrusted to Messrs. Kirk and Randall, contractors, of Woolwich.

The urban district council of Ashford, East Kent, have voted a gratuity of £100 to their surveyor, Mr. Terrill, in recognition of his services in connection with the new reservoir.

MEETINGS FOR THE ENSUING WEEK.

MONDAY.—Society of Engineers. 7.30 p.m.
Royal Institute of British Architects.
"Artistic Copyright," by M. Georges Hamand, Avocat à la Cour d'Appel, Paris. 8 p.m.
Liverpool Architectural Society. "The Royal Insurance Buildings, Liverpool," by J. F. Doyle, F.R.I.B.A.

TUESDAY.—Builders' Clerks' Benevolent Institution. Annual Dinner, King's Hall, Holborn Restaurant. 6 for 6.30 p.m.
Society of Arts. "The British Empire, its Resources and its Future," by John Lowles, M.P. 8 p.m.
Institution of Civil Engineers. Discussion on "Extraordinary Floods in Southern India." 8 p.m.

WEDNESDAY.—Edinburgh Architectural Society. "Building Stones: their Uses and Preparation," by John Kennedy, 8 p.m.
Edinburgh Architectural Association. "Fever Hospital Structure," by Baitie Pollard. 8 p.m.

CHIPS.

The town council of Hastings have raised the salary of their borough surveyor to £800 a year.

The Bishop of London opened, on Wednesday week, the new schools which have been erected at Kingswood-road, Fulham, by the London School Board.

An hotel is about to be built on Saunders Hill, Padstow, from plans by Messrs. Crickmay and Sons, of Westminster and Weymouth.

Saturday afternoon saw the formal opening of the New Marine Park at New Brighton, recently acquired by the Wallasey Urban District Council. The park is situate opposite the Convalescent Home, and adjoins the shore. In area it covers 16,540 yards, and was purchased at 5s. per yard, the total cost being £4,135. Besides the sums spent on road-making, the laying-out and inclosing of the plot cost £6,235, making the total cost £10,370. The work has been carried out by Mr. W. H. Travers, the engineer to the urban district council.

Some notes on the life of timber bridges were contributed by Mr. E. S. Meloy to a discussion on "Wooden Piles and Bridges" at a meeting of the employés of the Bridge and Building Department of the Chicago, Milwaukee, and St. Paul Railway. From the records of over 100 miles of wooden bridges, Mr. Meloy concludes that the life of the floors in pile bridges is from 7 to 11 years, the average being 9 years 1 month. Howe truss bridges have a very similar span of life, the average age at which renewal was effected being 9 years 6 months. The wooden floors of iron bridges were longer lived, the average age at renewal with them being 10 years 2 months. Wooden bridges required inspection twice a year.

The committee of the Co-operative Wholesale Society, Limited, have selected from 168 candidates Mr. A. A. Blackburn, of Dewsbury, for the position of electrical engineer of their large works near Manchester.

Mr. James Holme, estate agent, Westminster-buildings, Crosshall-street, Liverpool, was on Saturday morning found dead in bed at his residence, 10, Huskisson-street. Mr. Holme, who was 59 years of age, had for some time suffered from heart disease, and his general state of health had given his friends some concern. The deceased's father, James Holme, was chief magistrate of Liverpool in 1857-58, and his uncle, Samuel Holme, in 1852-53.

The Local Government Board has sanctioned a loan of £3,510 for the improvement of footpaths at Falmouth.

An outbreak of fire occurred on Saturday in a sawmill and woodyard on the St. Fort estate, in Fifeshire, where the whole erections and stock of cut wood were destroyed, the damage being estimated at £1,000.

A design for an altar rail in bronze, prepared by Sir Arthur W. Blomfield, A.R.A., has been adopted by the Dean and Chapter of Canterbury as part of the scheme of restoration for the cathedral. It is also in contemplation to restore the figures of the Archangel St. Michael, from which the Bell Harry Tower—the Angel Tower of olden days—derived its name. It was destroyed by the Puritans about the year 1500.

The almshouses under the management of the Coopers' Company, situated in School House-lane, Ratcliff, are shortly to be pulled down, as the site is required for the erection of modern buildings. The inmates will in future receive pensions and reside with their friends. Several of the houses have been empty for some time, and last week the 13 remaining occupants removed their furniture to their new homes, and bade farewell to the old quarters. The old buildings, which were built over 100 years ago, after a fire which occurred on the spot, are to be immediately demolished.

Trade News.

WAGES MOVEMENTS.

GREENOCK.—The Greenock and district plumbers have demanded an increase from 8½d. to 9d. per hour. A further request for a winter wage of 10d. per hour they are willing to withdraw, but they threaten to strike if their demand for increase to 9d. is not complied with by Friday.

MANCHESTER.—At a meeting of the rivers committee of the Manchester Corporation on Monday, a letter was read from the Local Government Board in which that authority refuses to sanction the committee's scheme for dealing with the sewage effluent by what is known as the bacteriological system, unless the corporation will undertake to acquire 200 acres of land on which to carry out the system. It was resolved to hold a special meeting of the committee to consider the situation.

NORTHUMBERLAND.—The strike in the Blyth painting trade has been settled, an amicable arrangement having been arrived at between the employers and workmen over the question of apprentices, which was the chief point in dispute. The strike began on the 16th March.

A project is on foot for a direct railway from Thun to Brieg, in the Canton Valais, via the Loetschberg. For the purposes of this line a main tunnel will have to be pierced over seven miles in length, and over 4,000ft. above the sea-level, the cost of construction being estimated at £1,500,000 sterling.

On Saturday afternoon the memorial-stone of a new Masonic temple in connection with Stevenston Thistle and Rose Lodge, No. 169, was laid by Mr. Hugh R. Wallace, of Busbie, Provincial Grand Master of Ayrshire. The new Masonic temple is situated in New-street, Stevenston, adjoining the present Lodge premises, and is erected from plans prepared by Mr. John Armour, architect, Irvine.

The promoters of the Folkestone District Light Railways do not intend to proceed with the application to the Commissioners for the order for the construction of the proposed railways in Folkestone, Sandgate, and Hythe.

Brocksley Hall, the seat of Lord Yarborough, near Grimsby, was the scene on Sunday morning of a serious fire, by which the whole of the north-east portion of the building, including the library and a number of bedrooms, was destroyed. Many valued heirlooms and manuscripts were destroyed. The damage is estimated at £20,000.

The town council [of Richmond, Yorks, have decided to build a farmhouse and buildings on the estate of 201 acres at Aislebeck, from plans by their borough surveyor, Mr. Wetherell. The estate, which has hitherto been leased, will be managed for the corporation as a dairy farm.

The town council of Brighton have under consideration the amendment of the building by-laws, the chief proposal being to reduce the stringency of the requirements as to the height and thickness of walls.

The corporation of Stoke-on-Trent inaugurated at their gasworks on Wednesday week a new gasometer, which has been built for the corporation at a cost of £7,000, by Messrs. W. C. Holmes and Co., of Huddersfield. The new gasometer will hold 430,000ft. of gas, and meets a 30-hours' maximum demand. It is on the telescopic principle, with three lifts, and has a steel tank 25ft. deep by 90ft. in diameter, which will contain a million gallons of water.

On behalf of the Local Government Board, Mr. W. W. E. Fletcher concluded, on Friday, an inquiry into the application of the Withington Urban District Council for power to borrow a sum of £5,500 for the purchase of land on which to erect an infectious diseases hospital.

Colonel A. J. Hepper, D.S.O., R.E., an inspector of the Local Government Board, held an inquiry at Widnes Town-hall on Friday into an application of the town council for sanction to borrow £3,850 for works of sewerage. The town clerk, Mr. Oppenheim, said the money was required to construct a new sewer in place of the central outfall sewer, which was the oldest sewer in the borough. Mr. J. Sinclair, the surveyor, gave evidence as to the need of the new sewer, and produced reports and plans.

A Local Government Board inquiry was held at Radcliffe, Lancs, on Friday, by Mr. Sandforth Fawcett with regard to an application of the Radcliffe District Council for powers to borrow £2,000 for works of surface drainage. It is proposed to replace the old-fashioned brick eyes, which are stated to be very insanitary, with stoneware trapped gullies. Powers to borrow upwards of £30,000 for sewers and sewage works have already been obtained.

LATEST PRICES.

Table with columns for Iron, &c. items, Per ton, and prices. Includes items like Rolled-Iron Joists, Wrought-Iron Girder Plates, Bar Iron, etc.

Table with columns for Sheet Zinc, Hot Blast, Wrought-Iron Tubes, Gas-Tubes, Water-Tubes, Steam-Tubes, Galvanised Gas-Tubes, Galvanised Water-Tubes, Galvanised Steam-Tubes, 10cwt. casks, 5cwt. casks, Sheet Zinc, Sheet Lead, Pig Lead, Lead Shot, Copper Sheets, Copper, Tin, Straits, Do., English Ingots, Spelter, Silesian, Cut Clasp Nails, Cut Floor Brads, Wire Nails, etc.

Table with columns for Timber items, per load, prices, and B.W.G. Includes items like Teak, Burmah, Bangkok, Quebec pine, Oak, Birch, Elm, Ash, Dantsic and Memel Oak, Fir, Wainscot, Riga p. log, Lath, Dantsic, p.f., St. Petersburg, Greenheart, Box, Sequoia, U.S.A., Mahogany, Cuba, etc.

Table with columns for Oils items, per ton, prices. Includes items like Linsseed, Rapeseed, Do., brown, Cottonseed, Olive, Spanish, Seal, pale, Coconut, Cochin, Do., Ceylon, Palm, Lagos, Oleine, Lubricating U.S., Petroleum, refined, Tar, Stockholm, Do., Archangel, Turpentine, American, etc.

LIST OF COMPETITIONS OPEN.

Table listing competitions with columns for project name, amount, and date. Includes entries like Cricklade-Water-Supply Scheme, Relper-Sewage Disposal Schemes, and Tipton-Laying Out Park.

LIST OF TENDERS OPEN.

BUILDINGS.

Large table listing tenders for buildings across various locations. Columns include project name, contractor name, and date. Locations include Ushaw Moor, Old Windsor, Morley, and many others.

BUILDINGS—continued.

Table listing building projects and architects. Includes entries for Otley-Thirty-one Houses, Maidstone-Riverside Store, Lowestoft-Salvation Army Buildings, Wakeley Bros., Fairbank and Wall, Architects, 3, Manor-square, Otley, Bradford, etc.

ENGINEERING.

Table listing engineering projects and companies. Includes entries for Bath-Reservoir, Innellan, N.B.—Renewal of Pier, Buxton—Heating Wesley Chapel and Schools, Rural District Council, I. Williams, Clerk, 30, The Paragon, Bath, etc.

FENCING AND WALLS.

Table listing fencing and walling projects. Includes entries for King's Lynn—Wrought-Iron Unclimbable Fencing, Corporation, E. J. Silcox, C.E., Borough Engineer, King's Lynn, etc.

FURNITURE AND FITTINGS.

Table listing furniture and fittings projects. Includes entries for Swindon—Iron Bedsteads, Mattresses, &c., to Victoria Hospital, Thos. Roberts, Secretary, Swindon, etc.

PAINTING.

Table listing painting projects. Includes entries for Rochdale—Infirmary, Henry Booth, Secretary, 58A, Yorkshire-street, Rochdale, etc.

ROADS AND STREETS.

Table listing roads and streets projects. Includes entries for Batley—Paving and Flagging Crown-street, Goodall's-yard, O. J. Kirby, Borough Surveyor, Market-place, Batley, etc.

# THE BUILDING NEWS

AND ENGINEERING JOURNAL.

VOL. LXXIV.—No. 2257.

FRIDAY, APRIL 8, 1898.

## WORKMEN'S COMPENSATION AND EMPLOYERS' LIABILITY.

WE have already referred briefly to the provisions of this momentous Act, which comes into operation on the 1st of July next. As many of our readers are concerned with the new Act, it is important that they should make themselves acquainted with the requirements of the new law, whether as employers who will have to reconsider their position and their liability to make provision for any of their workmen, or as workmen who will be much benefited by the Act, and who will be anxious to find out their rights and their mode of action. The Act will certainly add considerably to the responsibility of the employer, for he will be liable to pay damages or compensation for personal injuries that have not been caused by any negligence on his part. The long and short of it is that the Act compels every employer who comes within the scope of the law to insure all his servants against injury.

Mr. W. Ellis Hill, M.A., in his comprehensive volume,\* which will be found of great use as a guide to the new Act as well as to the Employers' Liability Act, 1880, and the Factory and Workshop Act, 1878 to 1895, points out the leading object of the new legislation which is to soon come into operation. The burden of personal injury caused by accident during employment has, it will be admitted, been chiefly borne by the unfortunate workman himself according to common law. The Employers' Liability Act, 1880, happily altered this state of things, and so did the Factory and Workshop Acts, but they still left it impossible in some cases for the injured man to recover compensation from his employer. The Act which we are considering is intended to place the workman in a more satisfactory position, and make the employer responsible for any injury caused by his negligence, or by that of any person in his employ. In his introduction Mr. Hill observes: "It is difficult to see how any negligence on the part of an individual, and yet of an impersonal character, can exist. If a man is negligent, it would appear that he is guilty of negligence personal to himself, and therefore it may be taken that the law existing before the coming into force of that statute is left unaffected. Under the Act, however, the workman is given the right to proceed either under the law existing before the coming into operation of the Act, or, at his option, to take advantage of the provisions of the statute." The amount of compensation is the main thing, and therefore the workman will have to consider which course is the best for him to adopt.

At common law the workman had a right of action against his employer for any injury he sustained through personal negligence, and under the Employers' Liability Act he could recover damages for injuries sustained through negligence of any persons for whom the employer was answerable. The workman or claimant for compensation had to prove negligence on the part of employer, and that such negligence was the direct cause of the injury; but it was generally difficult to prove these two things—it was difficult to say what the duty was, or how much. The contract, express or implied, had to be considered before the duty of the master could be found; so that, as a conse-

quence, when a workman was injured at his work by the negligence of those employed by the same master, he could not recover if a contract of employment existed. That he suffered by the negligence of some workman in the same grade as himself was no doubt often the case. Yet it was hard, too; for the injured man might know that his comrades were working dangerously, but he did not like to complain to the employer or foreman of the fact. The Employers' Liability Act so far altered this relation as to make it more satisfactory to the workman. The effect was to throw a responsibility on the master for the injuries sustained through the negligence of men in his employ who were foremen or superiors of the injured man, and who, therefore, did not like to complain.

Mr. Ellis Hill deals with the liability of the employer under this and other Acts; but we mainly now treat of his liability under the Workmen's Compensation Act of 1897. By this Act a new principle has been introduced. It casts upon the employer a new statutory liability for injury, without reference to any duty or negligence on his part or those for whom he is responsible. This liability is confined to certain persons and employments to which the Act applies—namely, to employment on, in, or about a railway, factory, mine, quarry, or engineering work, "and to employment by the undertakers on, in, or about any building which exceeds 30ft. in height, and is either being constructed or repaired by means of a scaffolding, or being demolished, or on which machinery driven by steam, water, or other mechanical power is being used for the purpose of the construction, repair, or demolition thereof." The liability is imposed on the employer even when the accident is caused by the negligence of the workman himself, if the latter has not been guilty of serious and wilful misconduct. The compensation is small in cases of mere injury, but when death ensues it is substantial. The first schedule gives the scale and conditions of compensation. The amount is to be, where death results, if the workman leaves any "dependants wholly dependent upon his earnings at the time of death, a sum equal to his earnings in the employment of the same employer during the three years next preceding the injury, or the sum of £150, whichever of those sums is the larger, but not exceeding in any case £300, provided that the amount of any weekly payment made under this Act shall be deducted from such sum, and if the period of the workman's employment by the said employer has been less than the said three years, then the amount of his earnings during the said three years shall be deemed to be 156 times his average weekly earnings during the period of his actual employment under the employer." If the workman leaves any dependants in part dependent upon his earnings, such sum not exceeding the sum payable under the foregoing provision as may be agreed upon on arbitration; and if he leaves no dependants, the expenses of his medical attendance and burial, not exceeding £10. In cases of total or partial incapacity for work, a weekly payment after the second week not exceeding 50 per cent. of his average weekly earnings during the previous 12 months if he has been so long employed, or, if not so long, a weekly allowance not exceeding £1.

Other conditions are given. It is remarked, as to the compensation for personal injury, that it is so small, and the chances of injury so infrequent, that the most economical course to meet such cases would be to insure against accidents.

Confining our attention to building accidents, it will be frankly admitted that the Act makes an arbitrary limitation as to the height of building, for unless it is over 30ft. in height, the trade does not come within the operation of the Act. This limit is bor-

rowed from the Factory and Workshop Act, 1895; so that if personal injury is sustained by a workman on or in a building which is, say, 29ft. high, there is no compensation. But there is no guide for the determination of the height; how is it to be determined? No definition is given. This is a question which will give rise to much difference of opinion. Those who framed the Act were only thinking of the risk incurred by the use of high scaffolding, building cranes, and other appliances. Should an accident occur and personal injury or death result in or near a building over the statutory height without scaffolding or machinery, the Act is inoperative. Under the head of demolition, the Act applies to any building being demolished over 30ft. in height, although no scaffolding or machinery is used.

Sub-contracting introduces another point. To prevent the evasion of liability, section 4 provides that the undertaker or head contractor is to pay compensation whenever the contractor is liable to pay it to the injured workmen, or whenever the contractor would be liable if he were an employer. The section goes on: "Provided that the undertakers shall be entitled to be indemnified by any other person who would have been liable independently of this section." A right is there given to the undertakers to recover what they have been obliged to pay to the injured man from any person who would have been liable independently of the section.

We have given here simply the broader features of the new Act, which has been so ably dealt with by Mr. Ellis-Hill. The decisions under the Employers' Liability Act collected in the appendix will be found to contain every important point likely to arise. All legal practitioners, employers, contractors, and others interested in the far-reaching powers of this Act ought to carefully study the sections and schedules. Insurance companies as well as employers are concerned with them to ascertain their liabilities, and the workmen also ought to know the privileges conferred by the Act, if only to arrange terms with their employers.

## MODEL SPECIFICATIONS.—VII.

### ORNAMENTAL BRICKWORK.

LAST week we made a few remarks on the subject of moulded and gauged brickwork, and we gave a few clauses for external facings, dressings, and pointing. The architect ought to make himself acquainted with the leading kinds of bricks or any local-made goods. For red-brick facings, the Fareham reds are best for weathering, and are of a nice, deep-red colour, and the Fareham "rubbers" for gauged work; there are also the "T. L. B." (Bracknell) red rubbers, and the harder gault bricks. "Picked stocks" are largely used for facings, also the "bright yellow stocks." The "Suffolk Whites" make good facings, and are suitable for gauged work. The best yellow malms and "seconds" are frequently specified. Then we have the Hartshill Brick and Tile Company (Messrs. Birks), Stoke-upon-Trent, as makers of first-grade bricks, tiles, terracotta, and paving bricks; while the excellent moulded bricks made by Mr. J. Brown, Whitechapel, furnish the architect with all the necessary materials for his ornamental brickwork.

We do not propose to enter into the subject of design; but many brick buildings show often a want of knowledge of certain rules of design. What is right in moulded work like terracotta is often undesirable in brickwork. For example, we sometimes see ornamental mouldings with sharp curves and angles which cannot be executed in cut or rubbed brick without much labour unless the bricks are specially moulded, as, for instance, a gable coping with two concave curves joining at an acute angle.

\* The Law and Practice relating to Workmen's Compensation and Employers' Liability. By W. ELLIS HILL, M.A., of the Inner Temple and Northern Circuit, Barrister-at-Law. London: Waterlow and Sons, Ltd., London Wall.

## Brick work

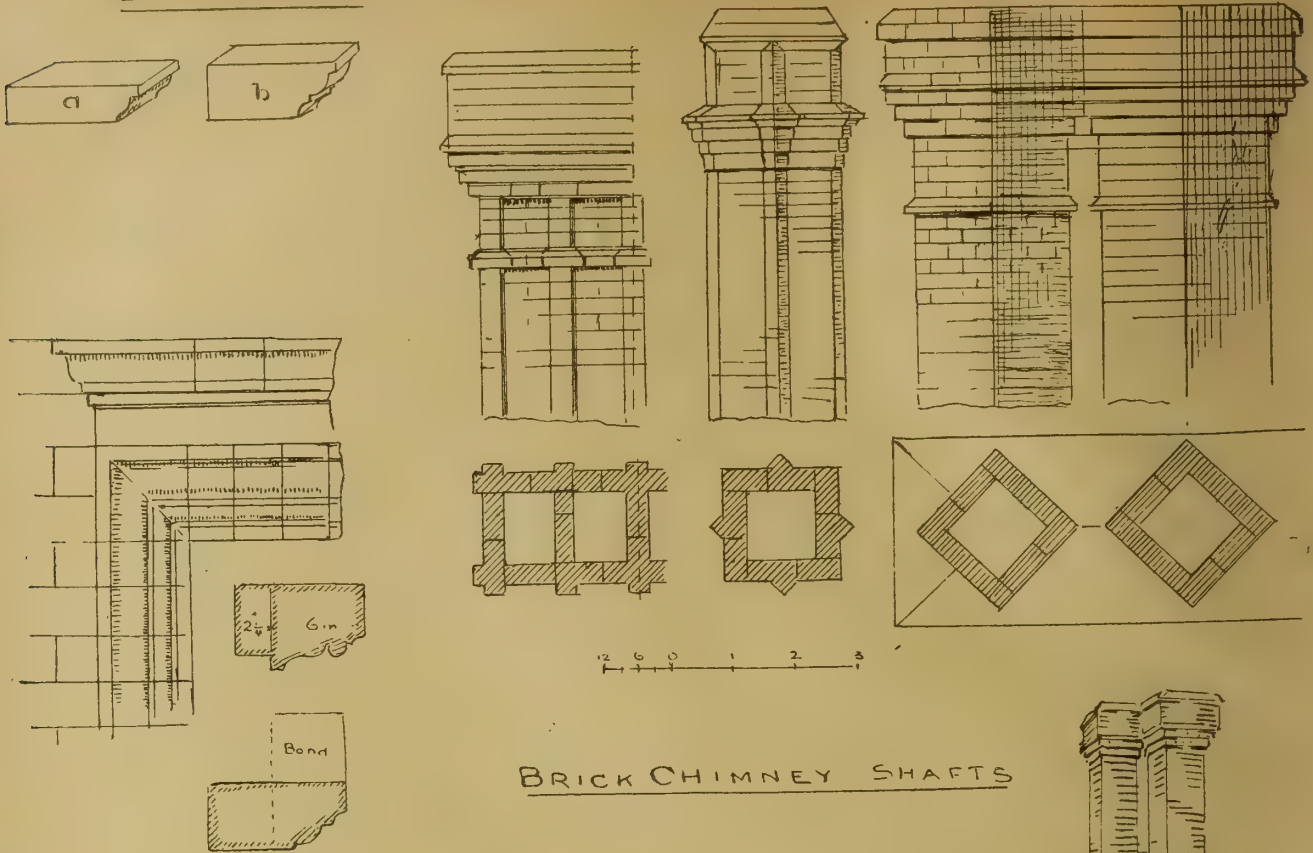

## Window Jambs

## BRICK CHIMNEY SHAFTS

Not only are these ornamental details unpracticable, but they are not consistent with good brick design—even moulded work. There is a taste just now for these and other rococo vagaries in design. What is tolerable in carved stonework or terracotta work is contrary to the principles that should govern brick ornament. Carved brickwork, such as we see in tympana, panels, shields, friezes, &c., can only be regarded as carving in stone, the joints being kept very close and the bricks of a soft, easily-chiselled quality; but such ornament should always be subordinated to the design and confined to small surfaces. The sketches we give explain themselves. In the design of brick moulded work, such as cornices and stringcourses, the architect ought to decide whether the work should be headers or stretchers. It is necessary also to bear in mind that the moulding, if on one end of the brick, may be made in the thickness of brick 3in., or in the width 4½in., (shown in *a* and *b*). For arches and curved work these are necessary. Moulded bricks for jambs or architraves generally have the moulding placed as in *b*, so as to line with the courses; on the next stretcher course the moulding is run on part of the length of brick to form bond with the header course, as shown in the sketch of jamb bricks. These bricks can be had with wider mouldings than 4½, and specially-made bricks for the purpose can be ordered.

We also show one or two sketches for ornamental chimney-stacks, with members or narrow pilasters worked in the sides. Many different arrangements are possible with the use of these special-made bricks, and we show how the projecting pilasters are formed and the bond secured. In specifying chimneys, it is necessary to insist on such a clause as this: "Bond in the withes on every second course, and the use of bats to be avoided as far as practicable." The joints,

too, should be well filled up with mortar and cement. In ornamental stacks, where there are a number of flues, as in large town buildings, terracotta flue-pipes (as those made by Messrs. Doulton) can be used, and to save space, Boyd's iron flue plates, which are ½in. thick and 12in. square, having tongued and grooved joints, may be employed.

We illustrate also a moulded brick window jamb and the brick bond, also a gabled doorhead and pilasters for a doorway in brick, in "gauged" work, executed with Fareham or T. L. B. "rubbers" set in putty. The tympanum of the gable is shown carved. The rubbers used are of even texture, and when there is deep carving, it is better to use all "headers," and grout the back in solidly with cement. Carved work is better set in a composition of whiting and patent stopping, or shellac, and the bricks may be put together in this cement before putting it in place for carving.

In brick buildings a great many details occur which are often inadequately described in general clauses, and the builder can only gather the intention of the architect by referring to the contract drawings to an eighth-of-an-inch or a quarter-inch scale, if there are no details supplied. The consequence is that they are misinterpreted, or the contractor, if honest, is more likely to err on his own side. Omission rather than excess is the rule. We mean with regard to such details as the execution of quoins and reveals of openings, brick cornices, stringcourses, chimney-top courses, gauged arches, panels, and other features. The results are: Bricks not moulded to the design of a cornice are put in, or the cornice is arranged out of ordinary bricks, the jointing is in mortar instead of cement, the arches and courses are not set in fine putty, or are not properly backed in cement. In many cases

an inferior class of red "rubbers" are used. It should be the aim of the architect to write his clauses so as to prevent any of these things happening by specifying the exact kind of brick to be used; by showing by detail how it is to be cut and arranged with regard to other courses, to state the kind of cement joint and pointing, and other items.

Here follow a few clauses on jambs and reveals, gauged arches, brick cornices, and other details that usually occur:—

3. *Plinth*.—The plinth course to be formed in red Fareham (or moulded bricks of approved section), and to be 6in. or 9in. high, and project 2½in. from the face of wall above, in cement mortar. Or—

The plinth to be formed as shown in detail of red moulded bricks (sections described), set in cement; it is to project 2½in., and be of two courses. Or—

Form plinth course as shown in red moulded brick, projecting 2½in. from face of main wall (or to be finished at top with blue Staffordshire brick splay). Set out bond for upper openings, and make a "perpend" for every reveal, and avoid "closers" in the internal angles where possible.

4. *Moulded Brick Architraves*.—The window and door architraves and reveals to be formed as shown in detail for margin with moulded bricks made by J. Brown (or R. M. Whiting, or other maker) of the section No. 278 or 281, with bond bricks, mitre to head, and stop in cement mortar (or set in fine putty). The moulded bricks are to be made a little thicker than ordinary bricks, and the beds and joints rubbed true; and before the scaffolding is struck, the work is to be rasped or rubbed, and all arrises made straight and true. Or—

The jambs to be executed in approved red moulded bricks in stretcher and header courses, as shown by detail, set in fine mortar (or cement), and point with a neat weather joint.

5. *Mullions, &c.*—The mullions, sills, heads, &c., of windows marked in elevation to be executed in cut and rubbed (or moulded bricks) of the shapes shown in margin, set in cement mortar with a neat joint. The work to be rasped and rubbed, and true arrises to be made before the scaffolding is struck. Or—

Carry up bay window (or porch) in accordance

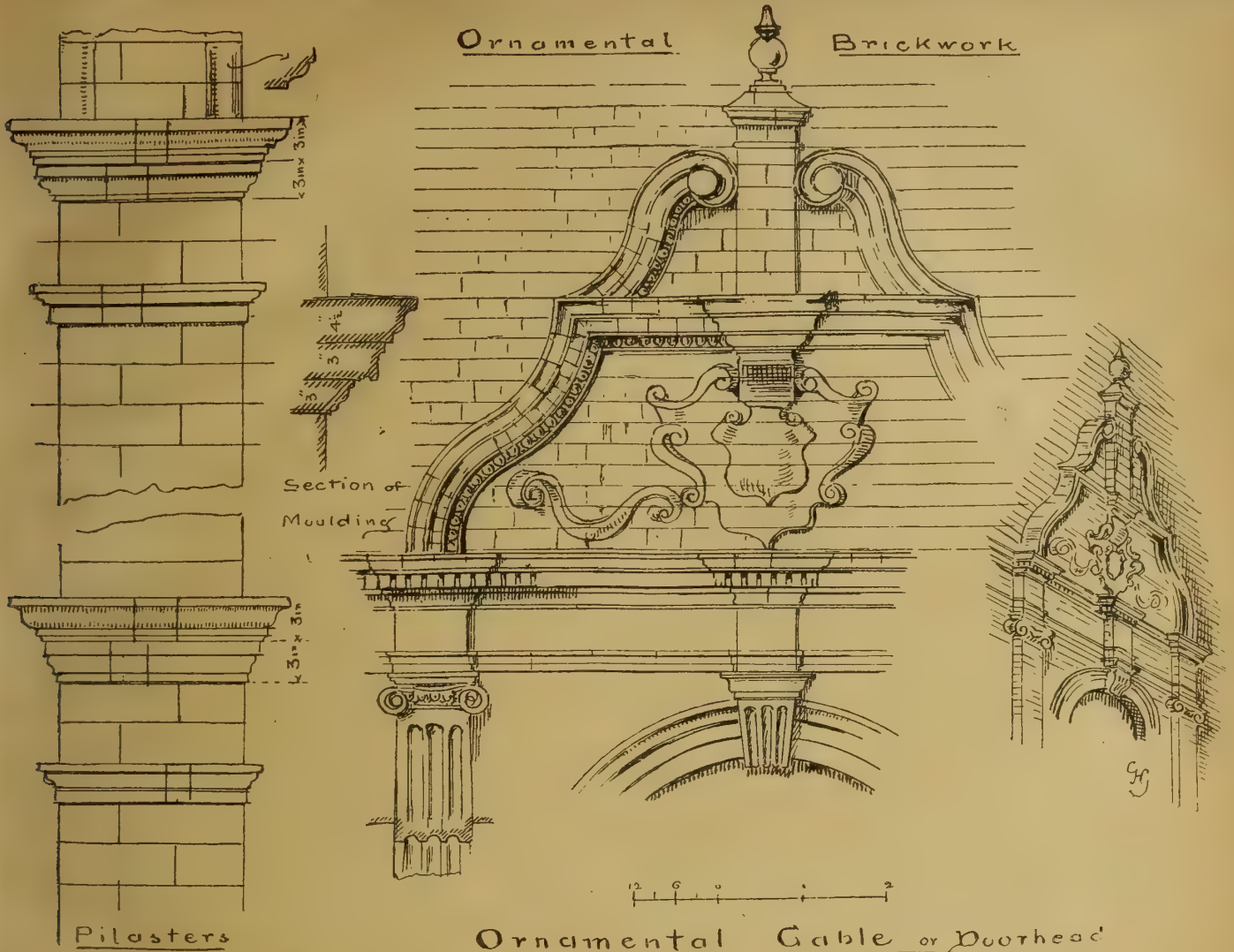

- with detail. The mullions to be built with special moulded bricks (name maker and number of section in catalogue if selected therefrom) with proper bond and with broken joints, with mitred corners and in cement mortar, worked as shown in detail.
6. *Gauged Arches.*—The external window and door openings to have carefully executed cut and gauged arches of red Fareham rubbers, or "T.L.B." red rubbers, or Suffolk whites, &c., with fine joints set in lime putty. Or—  
Turn accurately, with a cambered soffit  $\frac{1}{4}$  in. rise to the foot, cut and gauged arches in red "rubbers" (or best malms) over all openings 12 in. deep, and set in lime putty (or raked out and pointed to match facings). (If joggled joints, state so; also if there are stone "keys," &c.)
7. *Stock Brick Arches.*—All other arches to be "axed" of red (or other) bricks, 9 in. (or 14 in.) deep, with a camber of 2 in. or more (or to be segmental or circular) set in cement mortar.
8. *Brick Cornices.*—Form the cornice (state if the main, under eaves, or round chimneys) in cut rubbed and moulded red Fareham rubbers, with dentil or enrichment course as shown in detail with cement weathering (or put over top of cornices 5 lb. lead weatherings, well wedged into brick joint).
9. *Ornamental Gauged Work Generally.*—The ornamental moulded gables and carved brickwork, shown in sketch above, to be executed to design, details for which will be supplied. The best Fareham red bricks and rubbers, or "T.L.B." rubbers of approved colour, are to be selected for this part of the work (or use the best Suffolks). The moulded projections to be of three (or more) courses of the sections shown, all headers (or as shown). The carved enriched portions or "key" blocks to arches to be put together before placing in position, set in putty (or shellac) for carving, and to be all headers. Well grout the back solidly with cement. The architect will furnish a design for the ornament, and the carving must be done to the architect's approval. The mouldings, cornices, and string-courses to be weathered with two courses of tiles, breaking joint set in cement, or to be covered with 5 lb. lead well wedged into brickwork.

10. *Ornamental Gables.*—The copings of gables shown in elevation to be of red Fareham bricks of quality and make (or Lawrence's or Brown's moulded bricks, Nos. —), in two or three courses, laid in cement mortar (gauged 2 to 1) and finished with a neat weather joint. Or—  
Build the gables as shown in elevation and cope the same with the best hard burnt coping bricks or moulded bricks (name manufacturer), and of the sections shown in detail, in three (or more) projecting courses laid in cement mortar, finished with a neat weather joint, the moulded bricks to be rubbed and to form true arrises in straight lines and curves, the top course to be set and weathered in cement. Or—  
Form the gables over entrance, &c., as shown in detail, in cut, rubbed, and moulded brick rubbers, of Fareham reds or "T.L.B." red rubbers (or purpose-made moulded bricks). The moulded bricks to be in three (or two or one), projecting and enriched courses, with headers, as shown, all to be properly cut and rubbed to form the curves, with proper mitres set in lime putty, the upper course to be set in cement, and to be covered with 5 lb. lead weatherings well wedged into brickwork of wall behind.  
This clause would be suitable for gable we illustrate in sketch.
- — — — —
- SANITARY WORK.—IV.  
LAWS AND BY-LAWS.
- FROM time to time it has been found necessary to specifically define and enforce certain general sanitary measures in order to safeguard the interests of the public health. The more important of the statutes which relate to the various matters of public hygiene are as follows—viz.:—Public Health (Scotland) Act, 1867, 30 and 31 Vict. c. 101; Public Health (England and Wales) Act, 1875, 38 and 39 Vict. c. 55; Public Health (Ireland) Act, 1878, 41 and 42 Vict. c. 52; Public Health (Amendment) Act, 1890, 53 and 54 Vict. c. 59; Public Health (London) Act, 1891, 54 and 55 Vict. c. 76; Public Health

(Water) Act, 1878, 41 and 42 Vict. c. 25; Factories and Workshops Act, 1878, 41 and 42 Vict. c. 16; Housing of Working Classes Act, 1890, 48 and 49 Vict. c. 72; Contagious Diseases (Animals) Act, 1878, 41 and 42 Vict. c. 74, as amended by the Contagious Diseases (Animals) Act, 1886, 49 and 50 Vict. c. 32; Contagious Diseases (Animals) Act, 1894, 57 and 58 Vict. c. 57; Infectious Diseases (Notification) Act, 1889, 52 and 53 Vict. c. 72; Infectious Diseases (Prevention) Act, 1890, 53 and 54 Vict. c. 34; Rivers Pollution Prevention Act, 1876, 39 and 40 Vict. c. 75; Metropolis Water Act, 1852, 15 and 16 Vict. c. 84; Metropolis Water Act, 1871, 34 and 35 Vict. c. 113; Metropolis Local Management Act, 1855, 18 and 19 Vict. c. 120; London Building Act, 1894, 57 and 58 Vict. c. 213.

Of these, the Public Health Acts deal more particularly with the sanitary construction of buildings and their accessories.

Within the limits laid down by the respective Acts of Parliament, the different local sanitary authorities throughout the kingdom are empowered to make such regulations and by-laws as may be considered necessary for the proper drainage of houses. It is also provided that such by-laws must not be in any way repugnant to the laws of the country, and must have been previously confirmed by the Local Government Board. To assist sanitary authorities in framing suitable regulations, the Local Government Board have compiled a set of model by-laws for their guidance, and it is on these that most local by-laws are based.

It is now proposed to indicate the general sanitary conditions which are required in the Metropolis, so far as they relate to matters of ordinary house-drainage. These may be taken as fairly representative of what is absolutely necessary to secure satisfactory results.

Under the Public Health (London) Act, 1891, 54 and 55 Vict. c. 76, section 39, it is laid down that the County Council shall make by-laws with respect to "water-closets, earth-closets, privies,

ash-pits, cesspools, and receptacles for dung, and the proper accessories thereof in connection with buildings, whether constructed before or after the passing of this Act." Also that every Sanitary Authority shall make-by-laws "with respect to the keeping of water-closets supplied with sufficient water for their effective action." The examination of house-drains and sanitary fittings, together with the enforcement of all by-laws relating to the same devolve upon the various sanitary authorities.

For the purpose of carrying into execution this Act, the Metropolitan Sanitary Authorities are the Commissioners of Sewers for the City, and for all other localities embraced within the Metropolis or administrative county of London, the respective vestries, district boards, local board of health, board of guardians, or overseers of the poor, as the case may be.

The following is a brief outline of the by-laws which have been made by the London County Council under section 39 (1) of the Public Health (London) Act, 1891, so far as they relate to ordinary house-drainage.

Clause 1 states that every water-closet shall have an external wall for one of its sides at least, whilst an earth-closet must have external walls to not less than two of its sides. A water-closet must not be entered directly from a living-room, larder, or workshop. The entrance to an earth-closet must be from the external air.

Clause 2 requires that every water-closet or earth closet shall have a window with an area of not less than 2 superficial feet. The window must be placed in an external wall so as to open directly into the external air. Means of ventilation must also be provided, consisting of at least one air brick built in an external wall.

Clause 3 directs that the closet water supply shall be kept quite distinct from that for drinking purposes. Adequate flushing apparatus to be provided to each closet, the flushing pipe being not less than 1½ in. in diameter. An efficient siphon trap, with water seal, to be fixed under the closet basin. The use of D traps is not permitted.

Where two or more water-closets discharge into the same soil pipe, an anti-siphonage pipe of not less than 2 in. diameter must be provided to the closet traps, and ventilated into the open air at a point as high as the top of the soil pipe, or connected to the soil-pipe above the highest water-closet. The anti-siphonage pipe must be connected to the soil-pipe branch at a distance of not less than 3 in. and not more than 12 in. from the highest part of the trap on that side of the water-seal which is nearest to the soil-pipe.

Clause 4 states that for new buildings the soil-pipes are to be fixed outside. They must be not less than 3½ in. diameter, and carried up full bore above the roof of the building. The open end of the soil-pipe to be provided with a wire guard, and, where practicable, to be not less than 3 ft. above any window which may be within 20 ft. of the same. The weights for lead and iron soil-pipes of different sizes are as follows—viz.:

WEIGHTS FOR SOIL-PIPES.

Diameter.	Lead.—Weight per 10ft. length, not less than :	Iron.—Weight per 6ft. length, not less than :
3½ in.	65lb.	48lb.
4 in.	74lb.	54lb.
5 in.	92lb.	69lb.
6 in.	110lb.	84lb.

The connection between a lead trap or pipe and an iron soil-pipe or drain must be made with a brass thimble soldered to the lead pipe, the joint between the thimble and iron pipe or drain being run with molten lead and properly caulked. The junction between a stoneware trap or pipe and a lead soil-pipe must be made with a brass socket soldered to the lead pipe, the end of the stoneware trap or pipe being inserted into the socket and the joint made with Portland cement. In the case of stoneware and iron, the end of the stoneware trap or pipe is to be inserted into a socket on the iron pipe or drain and the joint made good with Portland cement. No soil-pipe must be connected with any rain-water pipe, bath waste, &c., nor shall there be any trap fixed between the soil-pipe and the drain.

Clause 5 directs that any alteration made to an existing water-closet shall comply with the foregoing by-laws.

Clauses 6, 7, 8, 9, 10, 11, 12, and 13 refer entirely to the construction of earth-closets and privies.

Clause 14 requires that notice shall be given in

writing to the clerk of the sanitary authority before carrying out works relating to the construction of waterclosets, earth-closets, privies, &c.

Clause 15 refers to the reconstruction of existing earth-closets and privies.

Clauses 16, 17, 18, and 19 deal with the provision of ash-pits in connection with buildings.

Clauses 20, 21, 22, 23, 24, and 25 relate to the construction of cesspools and dung-pits.

Clauses 26 and 27 insist upon the efficient cleansing and maintenance of all waterclosets, earth-closets, privies, cesspools, &c.

Clause 28 states that for every offence against the foregoing by-laws, the offender shall be liable to a penalty of £5, and in the case of a continuing offence to a daily penalty of 40s. for each day after written notice of the offence from the sanitary authority.

In addition to the by-laws of the London County Council dealing with the construction of water-closets, earth-closets, cesspools, &c., in the manner already indicated, the various local sanitary authorities—as represented by the respective vestries, district boards, &c.—have issued further regulations respecting the construction of drains and their accessories. These local regulations vary in almost every district; but it is probable that one uniform set of regulations will shortly be enforced by the different Metropolitan sanitary authorities. Such a consolidation of local drainage regulations would undoubtedly be advantageous in every way.

The regulations made by the vestry of St. Martin-in-the-Fields under section 76 of the Metropolis Local Management Act, 1855, 18 and 19 Vic. c. 120, are now given in order to afford a typical indication of what is required by Metropolitan local sanitary authorities in the construction of house drainage. In this instance they are as follows—viz.:

1. Seven days' notice of the intention to drain a house or building is to be given to the vestry. Forms of application can be obtained from the surveyor.

2. A second notice is required when the work has not been commenced within six months from the date of the application, and the sanction is given only to the person or persons making the application.

3. Such notice must be accompanied by a plan drawn to a scale of not less than 8ft. to an inch, accompanied by a block plan, showing the locality of the intended works, drawn to a scale of not less than 4ft. to an inch. The plan must show as much detail of the house or premises proposed to be drained as is necessary to enable a judgment to be formed as to the efficiency of the intended drainage. It must also show the position of all water-closets, sinks, bath wastes, &c., the lines of new drains with the sizes thereof to be shown in red, and any existing drains in blue upon the plan.

4. All horizontal pipes from water-closets shall have an internal diameter of 6 in. if of stoneware, and an internal diameter of 5 in. if of iron. For the drainage from areas, sinks, and subsidiary drains, 4 in. pipes may be used.

5. The whole of the available fall is to be made use of, and no drain to have a less fall than 1 in 40. In any case, however, where a gradient of less than 1 in 40 cannot be avoided, special provision shall be made for an automatic flushing of the drains by the adoption of an approved flushing siphon.

6. Each house or building shall have a separate drain in connection with the sewer, and no drain shall be laid under any house or building, should it be practicable to lay them outside of same.

7. The drains shall be laid in direct lines between the points of inspection wherever possible.

8. The drains of all houses and buildings shall consist of glazed stoneware pipes, or of cast-iron coated with Dr. Angus Smith's bituminous rust-prevention composition inside and out.

9. All pipes must be laid with watertight joints upon cement concrete, and where they pass underneath buildings they must, if of stoneware, be surrounded with not less than 6 in. of cement concrete in the proportions of one part of clean sharp sand, five parts of clean ballast, and one part of Portland cement—all by measure. Where the covering of pipes underneath any building is less than 1 ft., iron pipes shall be used with lead and gaskin joints.

10. The connection with the street sewer will be made by the vestry at the owner's expense, including so much of the work as will be beneath the public-way, and upon the estimated amount

of same being paid by the applicant to the surveyor to the vestry.

11. No drain shall be laid on the premises until the drain from the sewer to the premises has been laid in accordance with the above regulation.

12. For the effectual ventilation of the drains at least two untrapped openings shall be provided.

(a) One opening being at or near the level of the surface of the ground adjoining; such opening shall communicate with the drains by means of a suitable pipe, shaft, or disconnecting chamber, as near as practicable to the trap, which shall be provided between the main drain of the building and the sewer with which such drain communicates. Such opening shall be situated on that side of the trap nearer the building. (b) The second opening shall be obtained by carrying up from the point or head of the drains farthest distant from the first-mentioned opening, a vertical pipe or shaft to such a height, and in such a manner as effectually to prevent any escape of foul air from such pipe or shaft into any building in the vicinity thereof.

13. A suitable trap to be provided in every main drain which directly communicates with the sewer at a point as distant as may be practicable from the building, within the curtilage thereof, and as near as may be practicable to the point at which such drain may be connected with the sewer.

14. Immediately above the disconnecting trap a suitable inspection chamber shall be constructed, provided with an air-tight cover.

15. Junctions of branch drains shall in no case be made at right angles, but with proper junction pipes, having the branch pipe formed on them at an angle of 45° to 60° with the main drain in the direction of its flow; no cutting of pipes will be sanctioned, and no vertical right-angle junctions will be allowed except as inspection shafts, or for ventilation purposes.

16. Rainwater pipes, bath-wastes, and all wastes from sinks, hydraulic lifts, or other business appliances shall deliver outside the building on to open trapped gullies, or, if they must of necessity be within the building, on to special interceptors approved by the vestry, which must in every case be connected to the drains, and all inlets to the drains shall be properly trapped, except those inlets used for the purpose of ventilation. "Bell" traps will on no account be allowed.

17. Soil-pipes placed vertically shall be of, at least, 7lb. lead. They shall be of an internal diameter of 4 in., and placed, wherever practicable, outside the house or building, and in every case extended full-bore up to and above the eaves, finished with an approved cowl, at such a height as effectually to prevent any escape of foul air into any building in the vicinity thereof. The connection between the water-closet and the soil-pipe and ventilating pipe shall be of lead. Soil-pipes are not to be used as rainwater pipes.

18. The principle of construction of all water-closets is subject to the approval of the vestry. "D" traps, containers, receivers, and hopper-shaped pans cannot be permitted. Where a series of water-closets are placed one above the other, delivering into a common soil-pipe, the traps of each closet-basin must be specially ventilated to prevent siphonage by means of a 2 in. lead pipe turned into the main ventilation pipe.

19. No rain-water will be allowed to deliver on to the footways or roadways; water from the roofs, bay windows, cornices, &c., must be taken into the system of house-drainage.

20. Overflow-pipes from all cisterns, service-boxes, "safes," &c., must discharge, if practicable, direct into the open air, or be carried by means of lead or other suitable pipes, to a proper trapped gully or siphon.

21. The whole of any system of drainage must be approved by the surveyor before a single pipe is covered up, and the joints tested by charging with water or other means, should the surveyor so direct.

NOTE.—Under the Metropolis Management Acts persons are liable to the following penalties—viz., £10 for making drains contrary to the directions or regulations of the vestry. £50 for making drain contrary to the order of the vestry, and drain cut off from the sewer. £20 for building or encroaching on any sewer. £20 for interfering with any sewer without a license.

The by-laws of the London County Council, made under section 39 (1) of the Public Health (London) Act, 1891, and dated 28th June, 1893, are enforced by the sanitary authority.

A careful consideration of the by-laws and



regulations which usually obtain with regard to house drainage in the Metropolis, and a thorough compliance therewith—in the spirit as well as in the letter—would be productive of sound sanitary work in lieu of much that is at present dangerous to health.

### COPYING PROCESSES FOR REPRODUCING AND DUPLICATING DRAWINGS, PLANS, &c.

(Concluded from page 414.)

TO CONVERT BLUE PRINTS INTO BROWN OR SEPIA TONE.

**P**REPARE a bath of liquid ammonia that contains 22 per cent. of the ammonia gas, and dilute this by adding 18 parts of distilled water, and let the blue print remain in this fluid for two to four minutes; then rinse in clear water and plunge it into a filtered solution of tannic acid 2 parts, distilled water 100 parts, and let the print remain in the fluid for about twelve hours to intensify the tone produced. If not deep enough, add a few drops of liquid ammonia to the tannic acid solution; then take out the prints and wash them, when they look like sepia drawings. A way of converting the greenish-toned prints to blue is to dip them in a 1 per cent. solution of sulphuric acid. Another process of converting blue prints to brown is this. Prepare the following solution: Dissolve 2½ oz. of borax in 38 oz. of hot water, and when cool add sulphuric acid in small quantities until blue litmus paper turns slightly red, and then add a few drops of ammonia until the alkaline reaction appears, and red litmus paper turns blue; then add to the solution 154 gr. of red crude gum-catechu, and allow this to dissolve with occasional stirring. Immerse the blue print in this solution for a minute or two longer than it appears when the desired tone is produced, and then rinse in water; the resulting colour is olive or blackish brown. There are other methods of producing blue (and even green and red and violet) prints, of which the following are typical. Keep the paper which it is proposed to sensitise in a close box or canister, so as to keep it unexposed to light for a few days. Before sensitising this, float it in a bath of nitrate of ammonia prepared by 1 oz. of the nitrate in 5 oz. of distilled water. Allow the paper to remain in the bath four or five minutes, then lift it off, boxing it up in a dark room to dry. This paper so prepared can be kept for future use in dark receptacles. The exposure varies from one to several minutes in the sun's rays, and 15 to 60 minutes in diffused light. To develop the image thus produced, dip it for barely a minute in the following solution: 2 dr. distilled rain-water, 7 gr. of nitrate of silver, acetic acid a mere trace. As soon as the picture appears in perfect contrast to the surrounding surface of the paper, take it out and wash it in clear water, which will fix the print. To produce red prints, sensitise the paper by means of nitrate of uranium; drain and dry them in the dark, then expose beneath the drawing—done, of course, on translucent paper—for 8 to 10 minutes, then wash and immerse in a bath made up of 30 gr. of ferrocyanide of potassium, 3 oz. of water. When the picture appears in red colour, fix it by washing thoroughly in water. For a green print, proceed as above for red pictures, and then dip the red print in a solution of 30 gr. of sesquichloride of iron, 3 oz. distilled water. When the red print changes to green, wash it in water to fix the printing, and dry before a fire. For violet pictures, sensitise the paper with a bath made up of 2 oz. of distilled water, 2 dr. of nitrate of uranium, 3 gr. chloride of gold, expose for 10 to 15 minutes, and wash in water and dry. A mechanical method of reproduction is the following process: The materials required are Japanese paper, a copying press, and a smooth polished zinc plate. To prepare the ink for the process, make a solution of methyl violet, or any other suitable aniline dye in water, and mix 3 fl. oz. of this solution with 10 fl. oz. of water, and add about 25 minims of acetic acid. To prepare the negative, moisten the cover of a sheet of Japanese paper and lay it on the zinc plate. Smoothed out on this, place a linen cloth which has been soaked in water and wrung out, so as to be not too wet, and on top of this, under the sheet of zinc, lay a pad made of a sheet of paper folded together several times; remove the linen cloth from the Japanese paper, when the latter will be sufficiently moistened. In a similar way

moisten the sheet of paper on which the written matter appears, lay the written matter face down on the Japanese paper, place a sheet of paper over the written sheet, and put the whole on copying press. In a short time the Japanese paper will have taken a copy of the written matter (reverse to the original), and by laying sheet after sheet of damped paper on the Japanese paper negative, twenty or more copies can be readily obtained therefrom by putting the whole in the press each time. A ready means of taking a facsimile copy of a drawing done in ink which contains a salt of iron or copper, is to lay over it a sheet of paper which has been moistened with yellow prussiate of potash and pressing on it, when the iron or copper salt will react on the paper and leave a copy wherever it comes in contact with the ferrotype paper. Chemic-mechanical processes of reproducing drawings, written matter, &c., are familiar by reason of the hectograph and similar processes that depend upon material from which the reproduction is obtained. A simple means of duplicating drawings, &c., is this:—Prepare a compound of gelatine and glycerine (*vide infra*, the Hectograph) and spread it upon waterproof paper, and for the ink with which to make the drawing use the following fluid:—20 fluid ounces of water, 2 oz. of chrome alum, 1 oz. of sulphuric acid, 2 oz. of gum arabic. Place the drawing upon the gelatine layer on the waterproof paper, and then lift it off, and pour over the gelatine coating a solution of an aniline dye, but not too strong, in water, and absorb any superfluous colour which may remain on the surface by laying sheets of tissue paper on the gelatine coating. To obtain the copies lay sheets of paper successively on the prepared gelatine surface and apply a slight pressure.

#### THE HECTOGRAPH

consists of an absorbent pad of a gelatinous nature which absorbs a certain amount of a specially prepared ink with which the drawing or written matter is done, and by laying on the gelatine surface sheets of paper, and applying a slight pressure, a dozen or two copies can be obtained from one negative. In this process it is apparent that the copy on the gelatinous surface is a negative, and that the copies obtained therefrom are positives or facsimiles (not reversed) to the original drawing. There are several formulæ for preparing the gelatinous compound, the best of which are given below. Anyone with a little skill can make a suitable apparatus, all that is necessary being a shallow tray of tin or other material into which the gelatinous compound is poured, and, when set, it is ready for use.

Hectograph composition, No. 1: Ingredients: 1 oz. good edible gelatine, together with 6 oz. or 7 oz. of pure glycerine. Preparation: Soak the gelatine in cold water for 10 to 12 hours, so as to cause it to swell up but not lose its form separately. Put 2 oz. of common salt (kitchen salt) in 1 pint of water, and put it in a saucepan to boil. In this boiling salt water stand a gallipot or earthenware jar in which the glycerine is placed, and heat the glycerine until it is about 200° Fahr. Meanwhile pour off the unabsorbed water from the gelatine, and put the gelatine into the hot glycerine, and continue the heating for an hour, with careful stirring; but avoid whisking the mixture to a froth, or cause bubbles. When the mixture has been sufficiently heated, add 20 minims (20 drops) of essential oil of cloves, so as to prevent the mixture decomposing, and then pour the compound into the shallow tray which is to receive it. Place this on a perfectly level surface in a place free from dust, and let it remain undisturbed for at least five hours.

**NOTE.**—If the gelatine be of poor quality, the compound will not "set" or gelatinise; in such a case, less glycerine should be used with such gelatine. The compound, however, thus prepared need not be wasted, but reheated, and a little more swelled gelatine added. When once you have prepared a suitable compound, take special note of the proportion of ingredients, and also the exact particulars which were followed in preparing same. The object in using a salt-water bath is to obtain a higher temperature—salt water boils at a higher temperature than fresh water—and also to prevent it being vaporised too readily, for such vapour would be absorbed by the gelatine compound, and consequently liquefy it too much.

Before using the gelatinous pad thus prepared, pass a wet sponge lightly over the face of the gelatine, and allow it to nearly dry before taking

the first copy. If this precaution be not observed, the surface of the gelatine will be ruined by the first copy taken, as the gelatine will stick to the paper, and in lifting up same, it will more or less tear away the gelatine and produce a rough surface. The pad becomes worn out in time, but it need not be cast aside, as all that is required is to remelt the compound. After taking the required number of copies, wash the surface of the gelatine with a wet sponge so as to absorb out of it all the ink that remains therein; but if the gelatine pad is not required for several days, this washing is not necessary, as the ink will become absorbed out of the compound, and thus not interfere with a fresh drawing being laid on it. To use this pad, make the drawing with the special inks (see below). Allow the ink to dry, and then lay the drawing on the gelatine pad; slightly press the back of the paper drawing, so as to cause it to become in immediate contact all over; then gently lift up one corner of the drawing and strip it off the pad so as to carefully avoid blurring the inked portion. The drawing should remain on the pad about one minute before removal. To take the copies, hold the sheet of paper on which the copy is to be taken squarely and evenly above the surface of the pad, and then gently lower it to the surface of the latter, being careful that you do not shift it about after it has come in contact with the gelatine. Apply a slight pressure to the back of the sheet of paper, and then carefully lift it off by taking up one corner first, and stripping the sheet off. Proceed to take the other copies in a similar manner.

Hectograph composition No. 2.—10 parts of gelatine and 37½ parts of water (soaked), 37½ parts of glycerine, 5 parts of kaolin (china clay). The addition of the kaolin prevents the gelatine gelatinising too quickly, and at the same time renders the compound opaque and of a milky whiteness, which effectually disguises the actual composition of the compound.

No. 3.—10 parts of gelatine, 10 parts of dextrose, 100 parts of glycerine, baryta q.s. (the native barytes ground, or else the precipitate sulphate of barium may be used).

No. 4 (a cheap compound).—10 parts of good glue, 5 parts of glycerine, 2½ parts of barium sulphate, 37½ water.

No. 5.—10 parts of glue, 50 parts of glycerine, 2½ parts of kaolin or baric sulphate, 37½ parts of water.

No. 6.—3 oz. of glue, 15 oz. of glycerine, ½ oz. of kaolin, 11½ oz. of water. This will suffice for a tin trough 7 in. by 11 in. superficial. To prepare the compound on sheets instead of in troughs, proceed as thus described in the *Chemist and Druggist*:—"Soak 4 parts of best white glue in a mixture of 5 parts of water and 3 parts of a solution of ammonia until the glue is soft; warm the mixture until the glue is dissolved, and add 3 parts of granulated sugar and 8 parts of glycerine, stirring well, and letting come to boiling point. While hot, paint it upon white blotting-paper with a broad copying-brush until the paper is thoroughly soaked and a thin coating remains on the surface. Allow it to dry for two or three days, and it is then ready for use. An aniline ink should be used for writing, and before transferring to the blotting paper, wet the latter with a damped sponge and allow it to stand one or two minutes, then proceed to make copies in the ordinary way. If the sheets are laid aside for two days, the old writing sinks in, and does not require to be washed off."

**Ink for use with the Hectograph.**—No. 1:—Ingredients: 1 oz. of aniline violet or blue (2 R.B. to 3 B.), 7 fl. oz. of hot water, 1 fl. oz. of spirit of wine, ¼ fl. oz. of glycerine, a few drops of ether, 1 drop of carbolic acid to prevent decomposition. Dissolve the aniline colour in the water, and, on cooling, add the spirit and other ingredients, and put in well-stoppered bottle for use.

No. 2.—Black: 1 part of nigrosine soluble in water, 14 parts of water, 4 parts of glycerine. More glycerine, sugar, or gum arabic may be added to render it more copying.

No. 3.—Blue: 6 oz. cotton blue (aniline), C.B., 1 oz. glucose, ¼ oz. glycerine, 1 quart of hot water. Rub up the blue in the hot water until dissolved; then add the other ingredients, and strain through muslin while hot.

To prepare tracing paper for architectural use, take common tissue or cap paper (any size of sheet); lay each sheet on a flat surface, and sponge over (one side) with the following, taking care not to smear any part of the surface: Canada balsam, 2 parts; spirits of turpentine, 3 parts, to which add a few drops of old nut oil. A sponge

is the best instrument for applying the mixture, which should be used warm. As each sheet is prepared it should be hung up to dry over two cords stretched tightly and parallel about 8in. apart, to prevent the lower edges of the paper from coming in contact. As soon as dry, the sheets should be carefully rolled on straight and smooth wooden rollers about 2in. in diameter, covered with paper. The sheets will be dry when no stickiness can be felt.

To render tracing paper more translucent, so as to allow the finest lines to be seen through it, soak it in benzine by means of a cotton pad, so as to thoroughly permeate the fibre. Indian ink, water colours, or pencil take equally well upon paper thus treated. For rendering opaque drawing-paper translucent, so as to permit of a photographic image of the drawing done on it to be depicted on some of the sensitised papers above referred to, there is nothing better than to saturate it with benzine. As this rapidly evaporates, the paper will resume its normal opaque appearance without showing the slightest trace of the treatment to which it has been subjected. Benzine vapour is easy to catch alight at a low temperature, so do not use it in the presence of a light or flame.

Another process of rendering ordinary drawing-paper transparent consists in dissolving a given quantity of best castor-oil in one, two, or three volumes of absolute alcohol, according to the thickness of the paper, and applying it by means of a sponge. The alcohol evaporates in a few minutes, and the tracing paper thus made is dry and ready for use. The drawing can be made with lead pencil or Indian ink, and the oil removed from the paper by steeping it in absolute alcohol, whence the paper resumes its original opacity. The alcohol thus used can be preserved for diluting the oil used in preparing fresh supplies.

VARNISHES FOR DRAWINGS.

Size the print with a solution of gelatine, and allow to dry before laying on the varnish.

No. 1.—Dissolve 5oz. of mastic resin, 2oz. of sandarac resin, 1oz. of camphor resin, 16oz. of spirits of wine 95°.

No. 2.—10oz. mastic resin, 20fl.oz. spirits of turpentine. Digest till the resin dissolves, and thin with turpentine for use. H. C. S.

WROUGHT-IRON AND STEEL IN CONSTRUCTIONAL WORK.—XXXVI.

THE employment of trough flooring or decking has become nearly universal by reason of its combined efficiency and simplicity of construction. It secures strength without adding much to dead weight. The latter consideration is of very high value in all bridge work, in which it is desirable to lessen that dead weight which has to be carried by the bridge itself. It embodies the principle of corrugation or fluting, which has been so successfully applied in other ways. Steel is the material used. It is built up into a good many sections, ranging between the rectangle and the arch, and, in different dimensions, is used for all kinds of floors and roadways, ranging from the lightest sections suitable for floors of warehouses, to road bridges and the heaviest railway-bridges. It occurs in pitches from 4in. to about 3ft. 4in. It has displaced largely the buckled plates, both of cast and wrought iron resting upon cross-girders.

The trough floorings are immensely strong by virtue of their corrugated, splayed, or arched forms. They are in effect single girders, rigidly united, combining the strength of single girders with the distribution of the load over several so connected. For the latter reason, theory has been much at variance with regard to the allowances to be made for distribution of load, whether over two or three adjacent troughings. It is often the case that the troughing carries the whole load without any other aid. In railway bridges the sleepers aid in distributing the load. In many instances the abandonment of the ordinary cross-girders in favour of the troughing has not only lessened the cost, but has got over difficulties on the score of head room. Drainage, too, of bridge-floors is secured in a much better manner than with girders and ordinary plates, or with timber.

Trough floorings were originally invented for the purpose of dispensing with wood flooring, and, to a certain extent, with rail-bearers or short longitudinal girders placed under rails, and to dispense with the ordinary floor-girders. These

floorings were first patented by Mr. Barlow in 1856. In 1865 Mr. Crompton patented the Lindsay section, afterwards patented by Lindsay in 1882. Many other patents have been taken out for trough floorings, and some of these have become very generally used.

Troughings are variously arranged and variously connected to girders. Generally they are

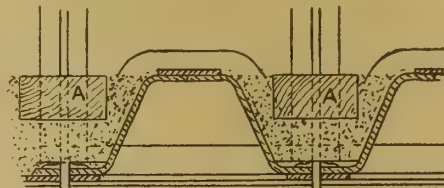

FIG. 258.

placed transversely. In long-span bridges this is always the case, and the transverse sleepers are laid in the hollows of the troughings imbedded in the ballast. The rail-chairs are spiked to the sleepers, so that the pitches or points of bearing of the rail are equal to the pitch of the troughing. In heavy troughing, packings are often laid on

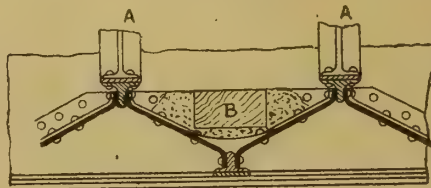

FIG. 259.

the crowns of the troughs intermediate between the sleepers and chairs, to increase the distribution and reduce the shear on the rivets. In road-bridges having spans not exceeding about 36ft., the troughing is often laid longitudinally, covered with concrete and wood flooring. The early troughing was generally too narrow and too

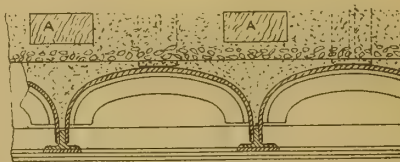

FIG. 260.

shallow, the idea being to obtain a better distribution of the load. But the modern practice is to use deep and wide sections, which distress the rails less, which cost less for riveting, and which present fewer possible sections of leakage. Troughing is often cambered to allow the rain-

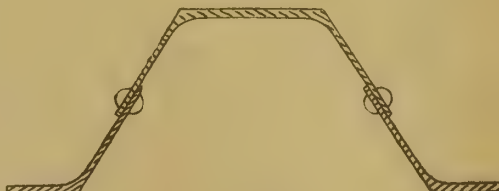

FIG. 262.



FIG. 264.

the cost of riveting, and the weakening effect of lines of rivets. Hence all modern troughings are stamped in sectional widths, which may be of half the pitch, or two, or three pitches wide. The succeeding figures show some of the trough sections most generally used for floors.

Westwood and Baillie's troughing is shown in Fig. 259. It is composed of rolled sections of steel plate, which are riveted at top and bottom. The timber sleepers A A are bedded in sand and gravel on asphalt in the troughs, so doubling the bearing surfaces for the rails.

Fig. 260 illustrates Hobson's diagonal trough flooring. In this the plates are splayed and riveted to top and bottom angles. The bottom angle is riveted to the bottom angles of the main girders, and the stiffeners A A are riveted to the top angles. The ends of the plates are riveted to the girder webs with angles. A layer of asphalt is laid over the plates, and sand and gravel above, in which the sleepers B are embedded. This is

not used so much as the arched flooring, seen in Fig. 261, which is adopted extensively, the pitch being generally 2ft. 6in., the plates being 1/2in. thick, 15in. deep in the middle of the arch. The plates are riveted to the sections which rest on the bottom flanges of the main girders. Asphalt covered with sand and gravel is used, the sleeper A being imbedded in the latter. Hobson's arched flooring was used on the Liverpool Overhead Railway.

Two sections of Lindsay's troughs for flooring are shown in Figs. 262, 263, as made by Dorman, Long, and Co. They consist of splayed



FIG. 265.

channels riveted at the sides. The section in Fig. 262 ranges from a weight of 19-06lb. per square foot covered to 51-83lb.; and Fig. 263 in 32-18lb. and 56-76lb., the latter being 1ft. 5 1/2in. deep and 3ft. centres, 5/8in. thick in sides, and 1in. thick at top and bottom, and being suitable for a double line of railway. The lightest section of 19-06lb. is but 4 1/2in. deep, 12in. centres, 3/8in. thick in sides, and 5/8in. at top and bottom. The firm make 15 different sizes, and give the moment of resistance for each, and tables by which the section suitable for carrying a given weight can be determined. Lindsay's flooring is used for road-bridges of short span, the troughing running longitudinally and the parapets being riveted to the top of the flanking troughs.

water to run off. This escapes through drain-pipes into guttering suitably arranged.

Trough floorings have been made as in Fig. 258 by riveting wide bars together with angles. In many cases the form has been rectangular, instead of that with sloping sides. The objection to the method of jointing shown in Fig. 258 is

It is also employed for the fireproof floors of public buildings. The troughing, filled with concrete, separates the floors, the flooring boards being laid on joists embedded in the concrete, and the lathing being attached to a backing of quartering which is bolted to the bottom of the troughing.

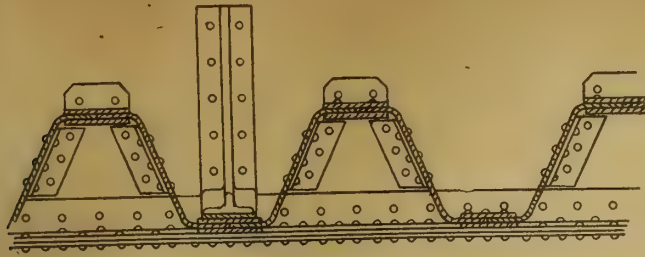

FIG. 266.

Two of Braithwaite and Kirk's floorings are shown in Figs. 264, 265. Fig. 264 comprises two Z-sections riveted at top and bottom, stiffening cover-plates being added. Fig. 265 is rolled

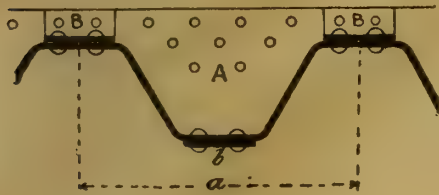

FIG. 267.

into the trough form, and riveted with single or with double riveting.

The ordinary trough floorings are attached to main girders by means of angles, either in the manner shown in Figs. 259, 260, 261, or in Fig. 266. Strickland's troughing, manufactured by

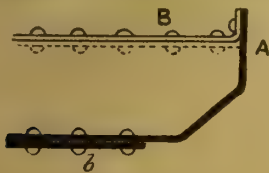

FIG. 268.

the Patent Shaft and Axletree Co., Limited, of Wednesbury, is of the usual angular type; but it is distinguished by the ends being boxed in, instead of open. The bent angle-irons, therefore,

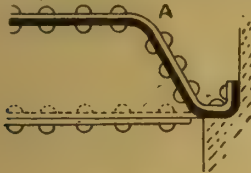

FIG. 269.

which are used to connect the ends of the open troughing to the webs of the main girders, are dispensed with entirely, the stamped boxed ends being attached directly to the girders. One advantage is, that there can be no leakage at the

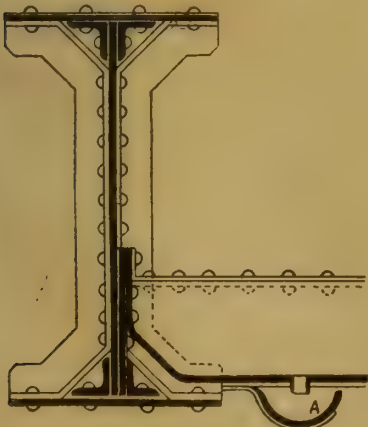

FIG. 270.

ends. Also, in the ordinary floorings, the girders are partly covered by the ends of the troughing, and cannot be painted. In the Strickland type

the girders are left exposed for painting. Another advantage claimed is that the ends of the troughs are suspended from the webs, instead of resting on the flanges, which latter tends to twist the main girders under heavy loads.

Fig. 267 shows a section through the troughing, where A is a turned-up end, riveted to the

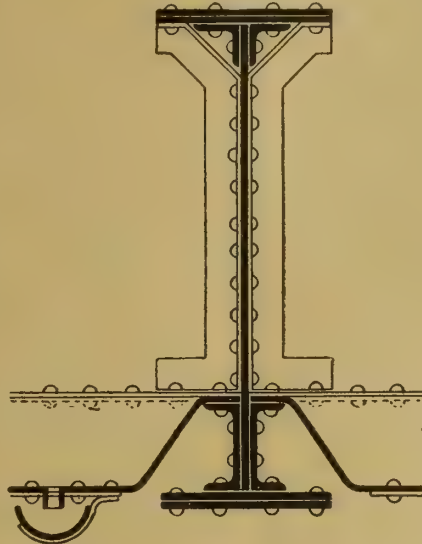

FIG. 271.

girder. The length *a* is the pressed width or pitch of trough, *b* is a stiffening bar, and B B are covers and stiffeners turned up at the ends and riveted to the girders. Fig. 268 is a section next the end, showing A, *b*, and B. Another method of fastening is shown in Fig. 269. Here the ends are turned up to the section shown, or in any other proportion, and the cover-plate A

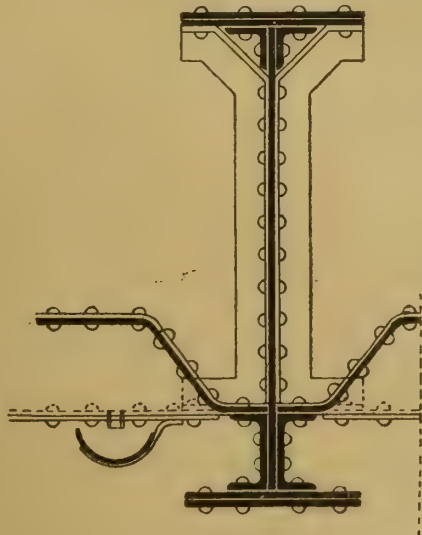

FIG. 272.

follows round the shape of the stamped end. Fig. 270 shows the end of the type in Fig. 268 attached to a main girder, with the drainage-pipe. The plate and cover are notched to allow the stiffener to pass down; but the stiffener is sometimes turned over on top of the trough instead. The drain-channel is seen at A, and with the troughing cambered the water runs to

the ends, and through the drain-pipes into the gutter.

Fig. 271 illustrates an attachment of Strickland's troughing to channel irons, which are

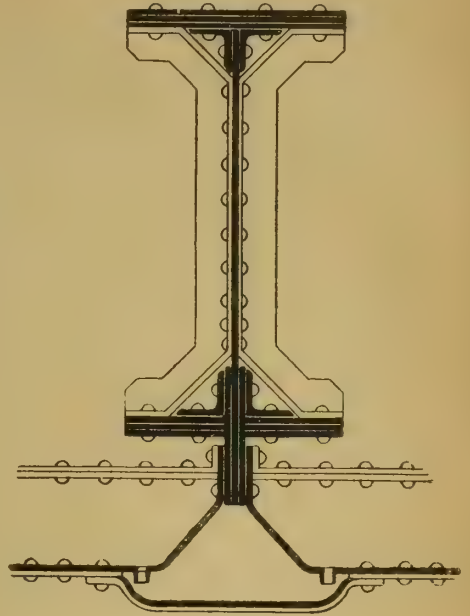

FIG. 273.

made to form the union between the web and the bottom flange of the main girder. The stiffeners stop at the troughing. The drainage gutter is seen; or, the troughing can be inverted on the



FIG. 274.

channels, giving greater head room underneath, as in Fig. 272. Fig. 273 shows the flooring suspended from the main girder, the webs being continued past the bottom flange, and reinforced



FIG. 275.

to take the strain. A single wide gutter is common to adjacent drain-pipes. For special strength the troughings are stiffened as in Figs. 274, 275; in the first case with double

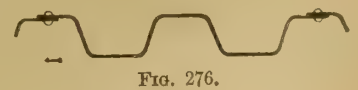

FIG. 276.

covers, in the second with tee sections. Very light sections are stamped as in Fig. 276, from 16in. pitch down to 4in. pitch, for warehouse floors and light bridges. J. H.

ROYAL INSTITUTE OF BRITISH ARCHITECTS.

RE-ELECTION OF THE PRESIDENT.

A SPECIAL general meeting of the Institute of British Architects was held on Monday evening. Mr. ALEXANDER GRAHAM, F.S.A., the chairman of the meeting, moved that in accordance with a recommendation of the council, Professor George Aitchison, R.A., be requested to allow himself to be nominated as President for the year of office 1898-99, and consequently by-law 26, which limits the duration of the

presidential term of office to two years, be suspended. This motion was seconded by Mr. JOHN SLATER, and was carried unanimously. A meeting for the confirmation of the resolution for the necessary suspension of the by-law will be held on April 18th.

An ordinary meeting of members was held immediately afterwards. Professor Aitchison, R.A., the President, who had not been present at the previous meeting, was summoned from the arbitration-room below and informed of the decision arrived at by Mr. Graham, who then vacated in his favour.

#### ARTISTIC COPYRIGHT, WITH SPECIAL REFERENCE TO ARCHITECTS.

A paper on this subject was read (in excellent and terse English) by M. GEORGES HARMAND, Avocat à la Cour d'Appel, Paris. The author explained that one of his objects was to give an idea of the state of opinion on the Continent regarding the question of copyright. Over the greater part of Europe architects enjoyed protection for the works they created, and it was of greatest importance that the profession in England should have the same privileges. Unity in the protection of their art was the best means to its development and its triumph. The fact that for a long period architects had not claimed copyright in their works was no reason against the right. There was ample evidence to show that from remote ages architects had been accustomed to put their names, or to leave some other trace of their personality, on the monuments they erected. Instances of the custom were cited by the lecturer from a paper read by M. Charles Lucas at Milan in 1892. Years before any other European country, England had promulgated laws for the protection of artists and authors. Till quite recently, however, the reproduction of architects' designs for publication was an expensive matter, and only monographs of a few very important buildings, or the works of a few very great architects, had been published—and that in exceedingly limited numbers. In the present day it was easy for architects to get photographic and other reproductions of their works, and for the sake of their own memory, their credit, and their fame, they should strive to secure the preservation of their drawings and the guarantee of their authorship. In England the rights of artists in reproducing their works by printing processes were protected by statute, architectural drawings being expressly mentioned: but English architects apparently lacked confidence in their rights, and hesitated to claim the protection of the law afforded them. The question of unification of the legislative measures relating to copyright had been well thrashed out at congresses held by the International Literary and Artistic Association in various cities of Europe; and, as a result, a convention was agreed upon at Berne, in 1886, between Great Britain, France, Italy, Spain, Belgium, Germany, &c., which provided for the grant of copyright to, among other works, drawings and works of painting and sculpture, to engravings, prints, &c., and to "plastic works relating to geography, topography, architecture, and sciences in general," also to any production belonging to literature, science, and art capable of reproduction by printing, &c. But the law of some nations party to the convention did not fully protect architecture. In Germany an architect enjoyed copyright in his designs so long only as they existed on paper; he lost his rights in his drawings as soon as a building was erected from them. In Great Britain, the lecturer understood, architecture was not protected by law, except for drawings and plans. Conferences had been held all over Europe by the association above referred to, and strenuous efforts made to secure full protection for architecture. Having dealt with the object of copyright, its privileges, the class of work whose authors were universally admitted to be entitled to the right, the lecturer went on to show that, by their methods of work and the nature of their inventions, architects were in a similar position to painters, sculptors, and other artists, and should be conceded the same safeguards for their protection. Quoting judgments of French and Belgian legal tribunals, emphasis was laid on a decision at Antwerp in October, 1893, where it was held that, in order to be considered the author of a protected work, it was not necessary for a man to produce a work entirely original in all its parts; it was sufficient that he had made a design, traced a drawing and plan, and infused his own individuality into elements

gathered from works whose copyright had expired. Such was an artistic creation which merited the protection of the law. The lecturer then touched upon the arguments adduced against the rights contended for, and having shown their unsoundness, proceeded to treat of the

#### RELATIONS BETWEEN THE ARCHITECT AND HIS EMPLOYER.

The architect furnishes plans and drawings, and agrees with his client for their reproduction in a building on a certain site. Such plans and drawings represent the original work of the architect. The client bargains for the possession and use of the building, and the enjoyment of its beauty, if it have artistic qualities. But, the lecturer contended, the right of reproducing the building on paper, by drawing, photography, or printing process did not pass to the client, but remained in the architect. If the client desired in any way to reproduce his building pictorially by engraving or other process, the architect could consent, for an agreed consideration, or he could refuse. The client, again, had no right to the original drawings, but only to copies, and this was sufficient to warn the client that the architect intended to keep the copyright for himself. The drawings handed to the owner should show some evidence of their being copies merely, and should bear the architect's signature. The owner had no right to repeat the building on any other site, or to permit anyone else to do so. The architect received fees calculated on the cost of the one building only. Repetition could only be made with the architect's sanction; and if repeated, he was entitled to fresh fees. It was important for the preservation of his rights that the original drawings should bear the architect's signature. His signature could not well be preserved on the buildings themselves; but as they were mere reproductions of his drawings, his interests would be sufficiently safeguarded by the signature being placed on the original drawings, and any copies, prints, or photographs of them. An architect could always print reproductions of his drawings under his own name; but the client had no more right to make prints or photographs of his buildings without the architect's consent than to repeat the buildings on another site. In concluding, the lecturer expressed his conviction that when architects felt that they could work and create for their profit, and have the reward of their pains and efforts, they would strive more after genuineness, and architecture as an art would progress, to the greater glory of beauty. If architects in Great Britain did not enjoy such rights in their creations as the lecturer had advocated, he hoped they would do their utmost to prevent the matter being overlooked in any new Copyright Act.

Professor ROBERT KERR, in proposing a vote of thanks, remarked that M. Harmand's suggestive paper was full of information with regard to other subjects also; but he feared the matter was looked at from very different standpoints here and in France. If in this country there was a chance of establishing anything in the nature of architectural copyright—and he for one did not regard it as possible—it would be a means of raising the status of architects. The fact must be faced that peoples of the Latin race were possessed of a faculty for art and its appreciation which we of the Teutonic race could not pretend to, and when the lecturer referred so eloquently to the architect's "glory," he was compelled to inform him that such a characteristic would not be recognised as a possibility in an English court of law, and that architectural copyright would fare badly in the hands of forensic gentlemen in this country. The difference between architecture and the other arts was practically very considerable, and the views that might be taken of architectural copyright in our courts of law might be this: that the common law recognised as deserving of protection that which possessed a commercial value and nothing else. If the architect could show a court what material damage he had sustained in pounds, shillings, and pence, his claim would be considered; but neither judge nor jury could understand any injury to his *amour propre*. The lecturer had throughout insisted on the merit of an architect's work lying in the architectural drawing and not in the executed building; but such a theory would not be recognised in an English court of law. It was well known to all English architects that our judges had ruled that the ownership of drawings was vested not in the architect who prepared them, but in the building owner

who ordered and paid for them; and that decision would not, he believed, be shaken, let them try as they might to do so. Certainly, any drawing, of whatever kind, could be protected against reproduction if the originator cared to register it and pay the fee. Again, an architect could, if he chose, patent any idea for a number of years, securing a monopoly in its use, on condition that he made its principle open or patent—but these were obviously very different from copyright. The principle that a man should not be at liberty to copy the arrangement, plan, and treatment he had ordered to be prepared for his own house, or that he should be prohibited from giving a friend permission to reproduce it, would not be tolerated in this country. A genuine grievance an English architect felt was that when he had been employed to design a house in the suburbs, two or three house agents would send emissaries to copy its leading points, paying these men as little as 5s. a piece, and that the design with which he had taken such pains was reproduced, more or less badly, all over the district. In conclusion, he could not agree that an architect should be protected to the same extent as a painter or sculptor, for his designs, except as means to an end, were not saleable as were theirs, and, therefore, the architect suffers no such pecuniary loss in reproduction.

Mr. JOHN SLATER seconded the vote of thanks, remarking on the excellent English in which the author had expressed his thoughts. All English architects were well aware of the decision of the judges as to the ownership of drawings, and although it was an absurd one, it could not be gainsaid. The only remedy the architect had was to draw so badly that it would not be worth the client's while to claim them, or to prove to the client that he was not paying for the mere drawings. He differed from Professor Kerr, and thought that the well-planned and designed building was just as saleable as the picture or statue would be, and he believed English architects would be only too happy if M. Harmand's efforts to secure an equitable international law of architectural copyright were successful.

Mr. JOHN HEBB thought the matter lay in a nutshell. At present it would be quite useless for an expert architect to assert a claim to copyright in his drawings in the face of the decision of the courts that this passed to the building owner. He was not sure, moreover, whether architects objected to being copied, for imitation was the most sincerest form of flattery. If they appealed confidentially to Mr. Norman Shaw or to Mr. Mountford, he believed they would not express annoyance that they had each, in their own way set a fashion among the younger men.

Mr. E. W. MOUNTFORD observed that it would be interesting to hear whether the experiences of a firm of architects in the North of England, who patented a particular plan in a competition design, had been satisfactory, and whether their example had been followed by others.

Mr. E. W. HUDSON reminded the members that in 1877, when a Royal Commission was inquiring into the question of copyright, the then President of the Institute, Mr. Charles Barry, gave evidence in which he demanded that architects should be given the right of reproduction extending over 20 years, but the Commissioners rejected his proposal. The architects' drawings which passed to the owner were the contract drawings signed by the builder, and therefore he did not see any objection in equity to the English law on the point. He referred in detail to the variations in Continental law on this point, observing that Austria and Hungary were governed by different regulations, while architects were better protected in Russia than in any other country.

In putting the vote of thanks, the PRESIDENT remarked that with small buildings the architect's remuneration was quite disproportionate to the time and labour expended on the plans, and it was annoying to see a design for, say, a farmhouse, prepared with much care, repeated all over an estate and the adjoining ones without acknowledgment to the author. At the same time, it would be so easy to make trifling alterations in materials or plan in execution, that it was not easy to copyright such designs. Architectural drawings were quite a modern idea; from the 6th to the 18th centuries all large buildings were erected from models, and the architect was also the contractor.

M. HARMAND, in replying to the vote of thanks, observed that while few English architects would agree with his views on copyright,

they would generally concur that the damage done to the author by imitation was twofold—first, he lost the remuneration to which he was justly entitled, and, secondly, he suffered in reputation from the poor and incorrect reproduction.

#### THE SOCIETY OF ARCHITECTS AND REGISTRATION.

THE question of "The Statutory Registration of the Profession" has occupied the minds of architects for many years, and the council of the Society of Architects is now taking steps to obtain the views of provincial architects upon the subject, with reference to which a Bill has been introduced into Parliament in the present session. With this object a meeting of architects was held on March 25th in the library of the Philosophical Hall, Park-row, Leeds. The chair was occupied by Mr. T. Walter L. Emden, J.P., L.C.C., President of the Society of Architects. There was a good attendance. In opening the proceedings, the chairman said they believed that if every architect were compulsorily submitted to examination, they would by that means be able to protect the public from men who were incompetent, and at the same time protect the profession from what he might call illegitimate competition. Mr. Ellis Marsland (hon. secretary) read a paper on the question. He asked what was meant by registration? It meant, in the present, that every man practising architecture should be duly enrolled in an official register under an Act of Parliament, and be duly responsible for his professional actions, and that no one be allowed to practice until he had been duly enrolled. In the future it meant that no one be allowed to practise architecture until he was duly qualified and had been found so by undergoing a qualifying examination. At present any person, with or without a fair general education, any builder, builders' foreman, clerk of works, clerk in a local board office, auctioneer, undertaker, "et hoc genus omne," with the sole qualification of being able to provide a brass plate, was at liberty to advertise him as a person qualified to give advice to the public in the science and art of architecture. Builders and others going out of their proper province boldly proffered their services as architects to their customers gratis; and the tempting bait of an apparent saving of 5 per cent. was not to be resisted. Could it be wondered at that they were still unrecognised while such a condition of things existed? For at present the public had no guarantee that the class who called themselves architects were any better qualified to plan and design their buildings than the contractors who erected them, and should they employ an architect they had no means of ascertaining that his knowledge was greater than that of the builder, and the only certainty about it from their point of view was that they would have to pay the professional charges. The advantages arising from registration were these:—Closing the doors to incompetent men; raising the standard of the profession; and obtaining the confidence of the public and State recognition. It was not proposed for one moment to say that all who desired to build should employ an architect; but what they did propose was that henceforth, in the interests of the public, no person should be entitled to call himself an architect whose name was not enrolled as qualified under an Act of Parliament, and any person wishing to employ an architect might, by consulting the official register, ascertain what men were qualified. Mr. J. Wreghitt Conr on (Leeds) moved the following resolution:—"That this meeting cordially approves the principle of the statutory examination and registration of architects, and is of opinion that it is desirable, in the interests of the public and the architectural profession, to promote a Bill in Parliament for the attainment of this object." He thought they were all agreed that the profession of architecture was by no means in the position it ought to occupy, or that it was in the possession of those facilities or advantages which it was entitled to possess. For instance, they would be agreed that the profession fell very far short of the professions of law and medicine in the facilities which were afforded it for educational purposes. They would also be all agreed that under existing conditions the profession of architecture did afford opportunities for entry into it of those who were not strictly entitled to belong to it; and he was sure they would all be agreed that the number of architects was certainly in excess of

the requirements of the population of this country. There were in the country some 1,500 more architects than there was any necessity for, and there was only one remedy for that state of things, and that was a system of legal registration of architects. He expressed regret that the Royal Institute of British Architects should not yet have seen its way to give its weight to this movement. When it became convinced that the great body of the profession throughout the country was in favour of it, it would then give it its support. Mr. D. Dodgson (Leeds) seconded the resolution, which, after a brief discussion, was carried unanimously. Votes of thanks to the president and the hon. secretary, proposed by Mr. W. S. Braithwaite (Leeds), and seconded by Mr. B. D. Fairbank (President of the Bradford Society of Architects), concluded the proceedings.

#### THE PROTECTION OF UNDERGROUND WATER SUPPLIES.

AT a meeting of the Society of Engineers, held at the Royal United Service Institution, Whitehall, on Monday evening, Mr. W. Worby Beaumont, president, in the chair, a paper was read by Mr. John C. Thresh, D.Sc., M.D., &c., entitled, "The Protection of Underground Water Supplies." The author pointed out in the first place that recent outbreaks of epidemic disease, due to polluted water supplies, had demonstrated in a terribly emphatic manner that there was either much wilful carelessness, which required to be rebuked, or much ignorance which required to be dispelled. The discoveries of bacteriologists had proved that these water-borne diseases were due to specific organisms, and these organisms might gain access to, and be carried by, a water otherwise organically pure, as well as by an organically contaminated water, although the latter water would almost certainly be more liable to specific pollution, and therefore be more dangerous. Underground water was derived from that portion of the rainfall which passed by percolation into the subsoil. In this country, nearly the whole of the exposed surface of the permeable strata was under cultivation, and on account of the facility with which water was obtainable, the population thereon was considerable. The subsoil water must therefore be contaminated at its source, and were it not that there were powerful natural agencies at work capable of producing perfect purification, underground waters would be too dangerous to be utilised for public supplies. Where such water was collected in close proximity to houses, from wells sunk in a sewage-sodden subsoil, it was notoriously liable to pollution, and was a prolific cause of the dissemination of disease. The records of the outbreaks of typhoid fever and cholera in this country were sufficient proof of that. These impurities, however, were not carried far in a compact permeable subsoil, although in a fissured stratum they might be carried very considerable distances. During the progress of the polluted water through the subsoil the organic matter became broken down, and finally oxidised or burnt up, the ashes (carbonates, chlorides, phosphates, sulphates) alone remaining to afford evidence of the previous contamination. The particulate matter, including the micro-organisms, was more or less completely removed by the process of natural filtration implied by the percolation, and it seemed certain that specific organisms gaining access to the subsoil water speedily perished. There was no record of any outbreak of typhoid fever being caused by underground water taken from a wisely-selected and properly-protected site. The investigations of Pettenkofer, the researches of Hanser, and the recent experiments of Martin and Robertson all tended to prove that the typhoid and cholera bacilli could only flourish near the surface and in a polluted soil, and Fraenkel had shown that the subsoil, even where the soil above had been grossly contaminated for a long period, was quite free from germs. That result, the author stated, he had recently been able to confirm in the examination of sand taken from various depths below the ground surface. At 4ft. very few organisms were found; below 5ft. none were discovered. These facts supported Koch's statement that "we have no reason to keep out of consumption the subsoil water which can be found nearly everywhere. On the contrary, we cannot find a better filtered water, and one more protected against infection." Although the use of water from shallow

wells sunk in populous neighbourhoods was not to be commended, there was very little doubt that in many such places a perfectly safe water could be obtained from the subsoil, from a properly constructed well, with clean immediate surroundings. Shallow wells supplying only a few houses, drew water from an exceedingly limited area, the cone of depression rarely exceeding 5ft. or 6ft. in diameter, and it was the ground surface over that cone which required special protection. A shallow well yielding 45,000 gallons of water per day, and depressing the water level 9ft., would produce a cone of depression with a base about 34ft. in diameter in a sandy subsoil. Round such a well there should be a protective area with a radius of 30ft., upon the surface of which no contaminating matter should be deposited, and which should be so guarded as to prevent the public having access. Encircling this should be an outer zone, which might be used for grazing purposes, but not otherwise manured. The area of this outer zone would have to be decided upon in each case after a due consideration of all the factors involved—such as the contour of the ground, the direction of flow of the ground-water, the depth and fluctuations of the water-level, &c. In certain cases an elliptical area would be preferable to a circular one, especially in the case of springs. Where collecting-channels fed the well, these should be not less than 10ft. below the ground-surface, and included within the protective area, and within the inner zone of that area if possible. Where wells were sunk in fissured strata, the form and extent of the protective area would require even more careful consideration, and should include the surface at which the fissures were most likely to outcrop. The water from the more freely flowing fissures should from time to time be examined, to ascertain whether any show signs of contamination; and if, after a heavy rainfall, the water became in the slightest degree turbid, danger was indicated. In the construction of deep wells, the greatest care should be taken to exclude subsoil water, and further, an area round the well should be protected, so that if any subsoil water did gain access, it would be free from the possibility of specific pollution. The use of the bore tube as the pump suction pipe was not to be commended, since the external atmospheric pressure would force air or water through the most minute aperture. Where the outcrop of the stratum yielding the water was within a few miles, it should be subject to examination, as impurities entering fissures might travel such a distance. Whether underground water be drawn from a deep or superficial stratum, the chief factor in guarding it from pollution was the provision of a protective area round the well or spring, under the absolute control of the purveyors of the water, the inner portion of the zone immediately surrounding the source being so protected that neither tramps, hop-pickers nor the general public could gain access. Existing sources of supply should be examined, and steps taken, if necessary, to secure adequate protection. Where, unfortunately, protection was impossible, it would be better to voluntarily abandon the works than wait until an outbreak of disease aroused public indignation, and compelled their abandonment.

#### BUILDERS' CLERKS' BENEVOLENT INSTITUTION.

THE twentieth annual dinner of this deserving and useful charity was held in the King's Hall, Holborn Restaurant, on Tuesday evening, and was more numerously attended than any previous festival. The chair was occupied by the president for the year, Mr. R. C. Foster, of the firm of Messrs. Foster and Dicksee, of Rugby, who by his frequent and pithy anecdotes enlivened the after-dinner proceedings, and among the 345 friends and subscribers to the Institute who supported him were Messrs. T. E. Colcutt, F.R.I.B.A., Edwin T. Hall, F.R.I.B.A., T. J. Bailey, F.R.I.B.A., William Woodward, A.R.I.B.A., Thomas Hall (Hall, Beddall, and Co.), ex-president, S. J. Dicksee (Foster and Dicksee), Joseph Randall (Kirk and Randall, of Woolwich), J. Howard Colls, Howell J. Williams, L.C.C., B. Eyres, C. Bussell, Octavius Newling, B. Hellyer, W. Nash W. Dyce, J. Ewitt, H. W. Parker, C. K. Turpin, E. C. Roe, &c. The loyal toasts having been given from the

chair, that of the "Army, Navy, and Reserve Forces" was proposed by Mr. W. Downs, and acknowledged by Mr. J. O. Belcher. In proposing the toast of the evening, "Success and Prosperity to the Builders' Clerks' Benevolent Institution," the President remarked that it was founded in 1866, and during the two-and-thirty years it had accomplished a great amount of quiet and beneficent work. It was established entirely by self-help. Two or three builders' clerks felt that sufficient was not being done for their class; and while it had been well supported by the body it sought to benefit, it had been most liberally supported by the builders and builders' merchants. So successful had it been, that its successive committees had distributed no less than £7,228 in pensions and temporary relief, and had purchased three presentations to the Orphan Working School at a further cost of 750 guineas in all, representing a total of £8,017. Having referred to the indebtedness of the institute to the courteous and indefatigable secretary, Mr. H. J. Wheatley, and the committee, the President added that the funds were administered on an economical basis, so that out of every 20s. contributed, 18s. was immediately available for benevolent purposes—a proportion which would compare favourably with the administration of most missionary societies, and certainly with the London County Council and our Government Departments. They had recently lost by death their genial friend Major E. C. Roe, for many years a member of this committee, and who was formerly a clerk in the employ of the speaker's father, and also Mr. Thomas Peto Ward, the actual founder of the institution, and one who had laboured zealously and faithfully in its behalf for many years as one of the committee. In appealing for liberal aid, the President added that during the year of office of his immediate predecessor, Mr. Thomas Hall, the largest income had been raised since the foundation of the institution, and he hoped that would now be exceeded. From the contractor's point of view, no body of men were more deserving of assistance than the builders' clerks. They were a competent and hardworking class; they formed no trade-union to bind or harass employers, and were not too exacting as to overtime, and the ranks of contractors were largely recruited from among them. The toast of "The Architects and Surveyors" was proposed by Mr. Howell J. Williams, who said that these professional gentlemen represented the bread and cheese of the contractor. He repelled the slur recently cast on our architects by Sir William Harcourt during the debate on the Government Buildings Bill. He had had the good fortune to travel over a great portion of the world, and had seen no finer example of modern Gothic than the Houses of Parliament, which were gained in competition, and if the Government, who were about to spend two and a quarter millions on new offices in Whitehall, would have the courage to throw the designing open to competition instead of restricting it, as proposed, to their permanent officials, he had no doubt that the younger architects would rise to the occasion, and show themselves well able to grapple with the problems set before them. Having referred to the surveyors, he deprecated the practice of some architects taking out their own quantities, as these were neither so full nor so reliable as those prepared by men who devoted themselves exclusively to that work. Mr. E. T. Hall, in responding, congratulated builders and their clerks that there was every sign of abundance of work for a long time to come. The very large scheme for building Government offices in Whitehall to which Mr. Williams had alluded must indirectly bring employment to the trade generally, and he was glad to see that there was a growing appreciation of architecture among the public, which in towns affected the great spending bodies, and stimulated them to provide themselves with more worthy and dignified buildings than were considered necessary in the past. Mr. Williams had referred in terms of praise to the Houses of Parliament, and we had no occasion to be ashamed of the work of our modern architects in this country, and going back two centuries, he held that there was no more beautiful building in the world than St. Paul's Cathedral, nor a tower and spire which surpassed Bow Church, while our Mediæval churches and cathedrals were equal to those to be seen anywhere. As to surveyors, he would assure Mr. Williams that it was the exception

for London architects to prepare their own quantities, and personally he deprecated the practice, for the architect was unavoidably biased to keep down the quantities, whereas the surveyor was perfectly independent of building owner or builder, and was more likely to see justice done on both sides. Mr. H. J. Oldham gave the toast of "London and Provincial Builders," remarking that for 20 years the Institution was almost entirely supported by Metropolitan builders and their clerks; but during the last seven or eight years they had looked further afield, and rightly so, as provincial builders and their clerks were carrying out more and more work in London. Their President, that evening, was an example in point, and he was endeavouring to bring provincial builders' clerks and their employers in as supporters of the funds of their most useful charity. Mr. J. Howard Colls responded in a humorous speech. The secretary, Mr. Wheatley, read a long list of subscriptions and donations, including the president and his firm, 25 guineas; the Institute of Builders, 10 guineas; Messrs. English Brothers, Wisbech, 10 guineas; John Mowlem and Co., 10 guineas; George Farmiloe and Sons, 10 guineas; Joseph Randall, 10 guineas; the Carpenters' Co., Eastwood and Co., W. Oliver and Sons, Nobles and Hoare, Thomas M. Rickman, B. J. Hudson and Sons, Farnley Iron Co., T. Lampard Green, Dent, Hellyer and Co., and T. W. Alsop, 5 guineas each; and Slater, Bird and Co., £5, and very many donations of lesser amount, including a large proportion from builders' clerks. The President announced the total amount as £480. Mr. E. B. Gammon proposed "The Builders' Merchants," which was acknowledged by Mr. T. W. Alsop. The remaining toasts were: "The President," given by Mr. Leonard J. Maton, and acknowledged from the chair, and "The Past Presidents," proposed by Mr. H. W. Parker, and acknowledged by Mr. Thomas Hall.

ELECTRIC LIGHTING NOTES FOR ARCHITECTS.—XX.

By AN ASSOC. INST. ELECT. ENGS.

MEASURING INSTRUMENTS AND TESTING.

**D**ETERMINATION OF RESISTANCES.—We have previously remarked that the resistance of conductors plays a most important

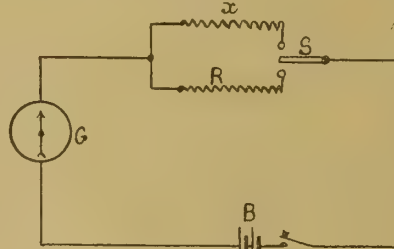

FIG. 63.

part in the distribution of electricity for commercial purposes, and we shall give here some methods of determining the resistances of conductors in practice. We must, of course, refer the reader to works dealing specially with electrical measurements for details, as we can only allude briefly to the everyday practical methods. In nearly all methods the determination of the resistance of a conductor is made by comparing it with others whose resistances are known. Probably the readiest and simplest method is by the fall of potential method. As is well known, a current traverses a conductor whenever two points in the conductor are maintained at different potentials, and its magnitude is limited by the difference of potential so maintained, and the resistance of the conductor between these two points. The relationship between these quantities is given by Ohm's law as follows:—

$$C = \frac{E}{R} \text{ and } R = \frac{E}{C}$$

where C denotes the current, E the difference of potential between the two points, and R the resistance of the conductor between the two points. If an ammeter be inserted in the circuit, and a voltmeter be connected between the two points, C and E are given by the readings of

these instruments, and the ratio between them gives R.

For the purpose of comparing the resistance of a conductor with others known, it is usual to have a number of accurate standard coils, arranged so as to form a resistance-box. These coils are constructed

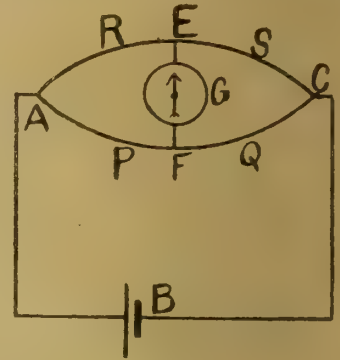

FIG. 64.

of metals possessing a high specific resistance and a low temperature coefficient, German-silver and platinum-silver alloy being largely used for this purpose. The wire is generally wound—doubled on itself—upon a wooden bobbin, and well soaked in paraffin-wax. This method of winding diminishing the self-induction of the coils to a minimum,

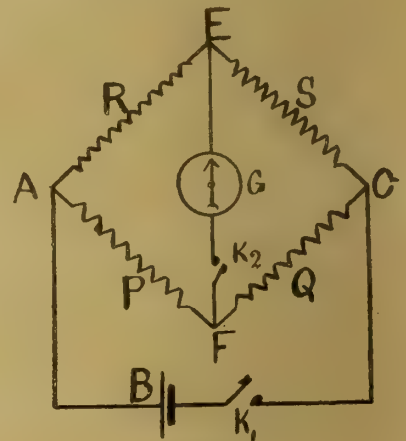

FIG. 65.

and the free ends of the coils are connected to separate brass pieces, as described under the heading of Post Bridge Box later on. By means of plugs, any desired resistance may be introduced into a circuit quite readily. Since these coils are usually wound with fine wire, none but weak currents should be sent through them.

*The Method of Substitution.*—By this method the conductor whose resistance is required is, placed in series with a sensitive galvanometer, and a source of constant electro-motive force. An ordinary Daniell's cell answers well. When

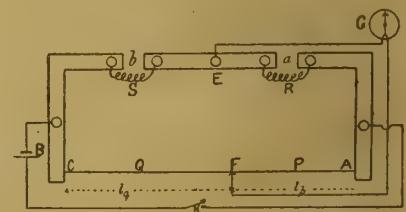

FIG. 66.

the galvanometer deflection is steady—that is, when the current is steady—the deflection is noted. The conductor of unknown resistance is then removed and replaced by a box of resistance coils, and sufficient resistance is introduced into the circuit by withdrawing plugs from the box to produce the same deflection as before, from which it is evident that the resistance so introduced will be equal to that of the conductor, which is required. If a number of determinations have to be made by this method, it is an advantage to use

a two-way switch, and to connect the conductor and resistance box as shown in Fig. 63.

In this figure, R represents the resistance box,  $x$  the conductor of unknown resistance, G the galvanometer, B the battery, and S the two-way

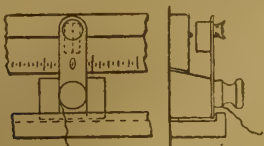

FIG. 67.

switch. The method of procedure is the same as that already given; but in this case it is not necessary to remove the conductor from the circuit. It is, of course, cut out of action by means of the two-way switch, and repeated observations may be quickly made to see if the battery has remained constant. The defect of this method is due to the fact that ordinary cells are not very reliable as regards their constancy, and it is advisable to take the mean of a number of read-

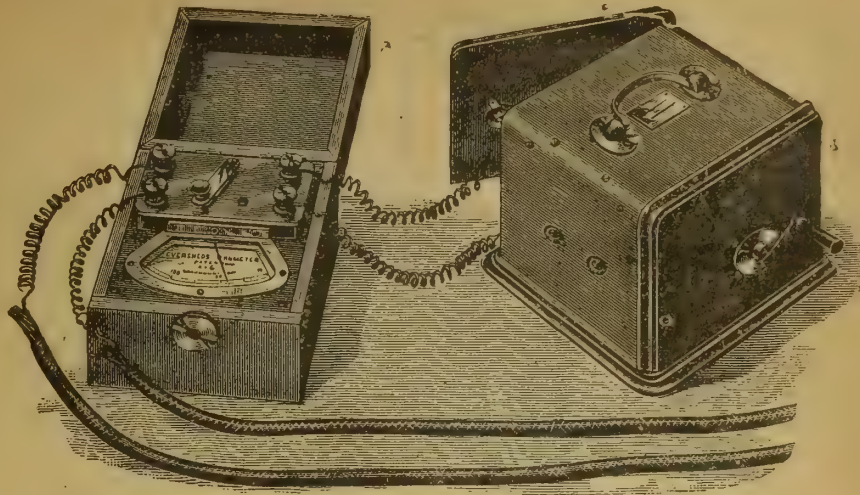

FIG. 70.

a conductor is proportional to the resistance of the conductor between the two points.

(2) If two conductors, AEC and AFC be connected in multiple arc between two points in a circuit, as in Fig. 64, there will be the same drop in volts along AEC as along AFC, and consequently two points, E and F, may be found, one in AEC and one in AFC, which have the same potential.

(3) No current flows along a conductor between two points at the same potential.

By combining these principles, an unknown resistance, R, may be determined in terms of a known resistance by adjusting the resistances P, Q, and S when arranged as in Fig. 64, so that the points E and F are at the same potential. From the figure it is evident that the current from the battery B divides at A, and unites again at C; and, as is well known, the proportion of the main current flowing along the two branches AEC and AFC depends upon the resistances of AEC and AFC. If, when we take the point E in AEC, the resistance of AE is R, and that of EC is S, and also that when the point F is at the same potential as E, the resistance of AF is P, and that of FC is Q; then if  $e$  is the drop in volts between the points A and C,  $e_1$  the drop in volts between the points A and E, and  $e_2$  that between the points E and C and between F and C, we shall have—

$$e = e_1 + e_2$$

$$\frac{e_1}{e} = \frac{R}{R+S} = \frac{P}{P+Q}$$

from which—

$$\frac{R}{P} = \frac{R+S}{P+Q}$$

also—

$$\frac{e_2}{e} = \frac{S}{R+S} = \frac{Q}{P+Q}$$

from which—

$$\frac{S}{Q} = \frac{R+S}{P+Q}$$

$$\therefore \frac{R}{P} = \frac{S}{Q} \text{ and } R = P \times \frac{S}{Q}$$

$$= S \times \frac{P}{Q}$$

P, Q, R, and S are the resistances of the conductors forming a balanced Wheatstone's Bridge, and from the relationship just determined we have means at hand of calculating the unknown resistance R of a conductor:—(1) When P, Q, and S are known quantities; or (2) When the resistance of one of the adjacent conductors to R—i.e., P or S, is known, and the ratio of the other two is also known. The conventional way of representing Wheatstone's Bridge is shown in Fig. 65, in which the same letters are used as in Fig. 64. In practice a sensitive galvanometer, G, is inserted between E and F so as to ascertain when these points are at the same potential. When the four conductors P, Q, R, and S form a balance or bridge, each is known as an arm of the bridge, and the two forming the ratio  $\frac{S}{Q}$  or  $\frac{P}{Q}$  (as the case may be) are termed the ratio arms.

If  $S = Q$ , then  $R = P$ , and if  $P = Q$ ,  $R = S$ . A moment's consideration also shows that these principles permit of several different ways of arranging the conductors so as to form a bridge, according as we may wish to adjust one or more

of the resistances P, Q, S in obtaining the balance.

Thus (1) both members of the ratio  $\frac{P}{Q}$  may be varied until balance is obtained, whilst S remains constant, and (2) the ratio  $\frac{S}{Q}$  may be maintained constant, and the value of P varied until balance is obtained. In this case the value of the ratio  $\frac{S}{Q}$  is usually made unity,  $\frac{1}{10}$  or  $\frac{1}{100}$ .

In practice, two forms of bridges are in common use, and these are constructed for working according to the conditions named in (1) and (2) above, and are termed respectively the *Mètre Bridge* and *Post Office Bridge*.

*The Mètre Bridge.*—A very convenient way of arranging the conductors forming a Wheatstone's Bridge, so that both members of the ratio  $\frac{P}{Q}$  may be varied at pleasure, is shown in Fig. 66, and is known as the *Mètre Bridge* pattern, on account of a wire 1 metre in length, and made of German silver or platinum wire, being used for the ratio arms of the bridge. This form of bridge is easily and cheaply constructed, and if used in conjunction with reliable standard coils, permits of great accuracy. Three connecting pieces, A, C, E, of stout copper or brass bar (the two former being right-angle pieces), to each of which binding screws are soldered, as indicated by the small circles, are firmly fastened to a board about 42in. long and 9in. wide, the inner edges of the right-angle pieces being exactly 1 metre apart. The German silver or platinum wire is tightly stretched and soldered between A and C, so as to be exactly one metre in length. Upon the board and under the wire is screwed a box-wood scale one metre in length, and divided into centimètres and millimètres. The same letters are used in Fig. 66 as in Figs. 64 and 65, and contact is made with the metre wire by means of a sliding key, K, which is free to move from A to C, so that the segments, into which the metre wire is divided by the key at F, form the two resistances P and Q. The construction of the sliding key is shown in Fig. 67.

In using this form of bridge, the ratio  $\frac{P}{Q}$  is varied by means of the key until balance is obtained, the actual position of F depending upon the ratio of R to S, which are two coils of wire inserted in the gaps a and b. The point F divides the metre wire into two sections,  $l_p$  and  $l_q$  millimètres in length, and since  $l_p + l_q = 1,000$  millimètres, the ratio  $\frac{P}{Q}$  may be written  $\frac{l_p}{l_q} = \frac{l_p}{1,000 - l_p}$  resistance being proportional to length. Therefore if the value of S be known—

$$R = S \times \frac{l_p}{l_q} = S \times \frac{l_p}{1,000 - l_p}$$

*Post Office Bridge.*—The second form of Wheatstone's Bridge is the Post Office pattern, which practically consists of a box containing twenty-two standard coils and connections arranged so as to form a very compact, and at the same time, complete bridge. A plan of the arrangement is shown in Fig. 68 I, and the complete box in 68 II. The free ends of the coils of wire, forming standard coils, are soldered to solid brass

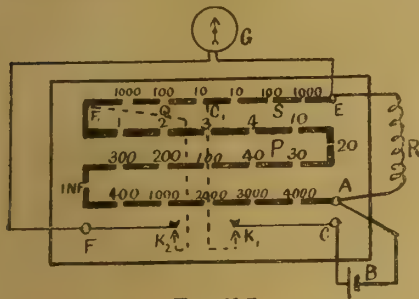

FIG. 68 I.



FIG. 68 II.

ings. If the galvanometer be very sensitive, it is often convenient to shunt it during the test.

*Wheatstone's Bridge.*—For everyday testing of resistances, where easy, rapid, and accurate determinations are required, the Wheatstone's bridge is employed. Wheatstone's bridge consists

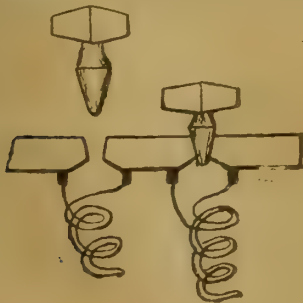

FIG. 69.

of a certain arrangement of adjustable resistances, and the principle of the method is very simple, depending upon the following elementary principles:—

(1) The fall of potential between two points in

pieces fixed to insulating material, and between the adjacent brass pieces there is a carefully formed conical recess, in which a stout conical brass plug with an insulating handle is inserted, as shown in Fig. 69. The coils are made of platinum-silver wire.

When the plugs fit the holes tightly, the resistance coils are practically short-circuited, and to place any coil in circuit the corresponding plug is removed. With this pattern of bridge the proportional or ratio arms, S and Q, each consists of three coils of 1,000, 100, and 10 ohms resistance respectively, and form the top row in the box. The ratio  $\frac{S}{Q}$  is maintained constant and equal to

unity,  $\frac{1}{10}$  or  $\frac{1}{100}$ , according to the degree of accuracy desired, and balance is obtained by varying the value of P. The rheostat arm P consists of a series of coils having the following resistances, 1, 2, 3, 4; 10, 20, 30, 40; 100, 200, up to 4,000 ohms, from which any desired value from 1 to 11,110 ohms may be obtained by removing the plugs; thus, 376 would be made up as follows:— $300 + 40 + 30 + 4 + 2$ .

When the plug marked I N F is removed, infinite resistance is introduced, and that part of the circuit is completely broken. The battery and galvanometer are connected to the terminals A and C and E and F respectively; the keys  $K_1$  and  $K_2$ , when closed, connect the pieces C and  $C_1$  and F and  $F_1$  together by means of the stout pieces of wire placed inside, and indicated by the dotted lines. The wire of unknown resistance, which has to be determined, is inserted between the terminals A and E. The method of using this form of bridge is as follows:—With the galvanometer shunted, determine the value of R to the nearest whole number by taking  $S = Q = 10$ . Then to the first decimal place, by taking  $Q = 100$  and  $S = 10$ , and finally to the second decimal place, by taking  $Q = 1,000$  and  $S = 10$ . In the final determination the galvanometer shunt should be removed.

**Measurement of Very High Resistances**—Although the Wheatstone's Bridge permits of a very wide range of measurement—from 1 ohm to 100,000 ohms—there are many cases for which this arrangement is not applicable, such as, for instance, the determination of the insulation resistance of an electric light or power circuit, which, to be satisfactory, should come out in megohms (millions of ohms). For these tests—the determination of insulation resistance—some form of portable testing apparatus is required, which usually includes a sensitive galvanometer, resistance coils, and a current generator, either in the form of a large battery or magneto-machine. Since extreme accuracy is not necessary, some form of an ohmmeter is mostly used, by means of which insulation tests may be quickly made, the insulation resistance being given directly in megohms by a pointer moving over a dial. An ohmmeter is an instrument for measuring directly high resistances, and it is so constructed that the position taken up by a delicately poised needle when working indicates the ratio of the pressure or P.D. between the ends of a conductor, and the current passing through the conductor. The ohmmeter was introduced by Ayrton and Perry, and, as improved by Mr. Sidney Evershed, is a very satisfactory commercial apparatus, and is much used. Furthermore, the whole testing set—consisting of a generator and an ohmmeter—is easily manipulated. The complete testing-set is shown in Fig. 70, and the construction of the ohmmeter will be understood from the following brief description and the diagrammatic sketch given in Fig. 71:—A and B represent two pairs of coils of wire fixed so that their axes are at right angles to each other, and the needle to which a light pointer is attached is pivoted at their centre. Coils A consist of many turns, whilst B is of much lower resistance; the two pairs of coils being connected in parallel as shown. It will also be observed that the resistance to be measured is connected in series with B, so that B may be termed the current coil, whilst the set A, which often has a high resistance, R, connected in series with it, may be looked upon as a shunt to the current coil.

In some of the earlier instruments the needle was a permanent magnet; but with these needles reversing the direction of the current through the ohmmeter impairs the accuracy of the instrument. In the latest patterns, therefore, the needle is made of soft iron, and is magnetised by the currents passing through the coils. To neutralise the effects of the earth's magnetism, a bar magnet is placed below the needle. For testing purposes,

the current is supplied by a small magneto machine, which sets up a pressure of about 120 volts when the handle is turned from 60 to 70 turns per minute. This generator is contained in a separate box (see Fig. 70), and should be placed not less than 3ft. from the ohmmeter when in use; otherwise the needle will be affected.

The indications of the needle of the ohmmeter obviously depend upon the relative intensities of the magnetic fields produced by the two sets of coils, and since the intensities of the magnetic fields are proportional to the currents passing through the coils A and B, which in turn are inversely proportional to the resistances of the two circuits, it is clear that the deflection of the needle depends only upon the ratio of the resistances of the two circuits. The position taken up by the needle is, of course, that of the resultant direction of the two fields, one of which is a measure of the current passing through the current coil; and the other is a measure of the

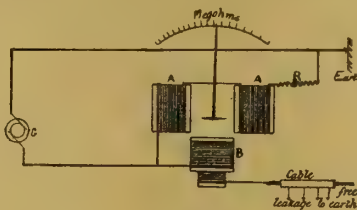

FIG. 71.

P.D. at the terminals of the instrument, and the ratio between the latter and the former is a measure of the resistance inserted. Thus, let—

$r_a$  = resistance of the coils A.

$r_b$  = resistance of the coils B.

$C_a$  = current in the coils A.

$C_b$  = current on the coils B.

R = resistance in series with the coils A.

$x$  = insulation resistance of cable.

E = P.D. maintained between the terminals of the ohmmeter. Then—

$$C_a = \frac{E}{R + r_a}; \quad C_b = \frac{E}{x + r_b}$$

$$\therefore \frac{C_a}{C_b} = \frac{x + r_b}{R + r_a}$$

Now, the ratio of  $C_a$  to  $C_b$  determines the position of the needle; consequently the position of the needle depends upon the ratio of the resistances. To calibrate the ohmmeter,  $r_b$  is eliminated, so that the scale reading gives the value of the insulation resistance  $x$ .

Each ohmmeter possesses a two-contact switch. By placing the switch-arm on one contact the range is from 0.1 to 5 megohms (for one size of ohmmeter), and by placing it on the other contact the range is from 10,000 to 500,000 ohms.

To use this testing set, the + and - terminals of the generator are connected to the + and - terminals of the ohmmeter, and for finding the insulation to earth, one end of the main under test is connected to the line terminal of the ohmmeter, the other end being perfectly free and open, whilst connection is also made between the earth terminal of the instrument and a good earth. With all switches turned on and the lamps removed, the insulation resistance of that main to earth is given with very fair accuracy upon working the generator. The insulation resistance of the other main is likewise tested. For the test as to the insulation resistance between the two mains, the earth connection between the ohmmeter and the earth is removed, and is replaced by the end of the second main, the further ends of both mains being open and perfectly free.

(To be continued.)

#### MR. LIONEL CUST ON PORTRAITS.

MR. LIONEL CUST, C.B., director of the National Portrait Gallery, gave on Saturday afternoon at the Royal Institution, the first of two lectures on "Portraits." Dealing with the subject of portraits considered as historical documents, he inquired, if portraits were valuable as illustrating the history of families, how much more valuable were they in illustrating the history of a nation? Since portraits might be regarded as historical documents, one would expect to find the nation treasuring up portraits as carefully as it had treasured up the records of its laws and plans and documents relating to military

achievements. It was instructive to see what England had done in this matter. Henry VIII., Mary, and Elizabeth all employed eminent portrait painters. Indeed the Royal families were the early patrons of the art, and Holbein might be regarded as one of the historians of the reign of Henry VIII., for to him we were indebted for our knowledge of the personal appearance of that king's court. His portraits were absolutely indispensable to the historian of that age. The arrival of Vandyck in this country was the beginning of a new epoch in the history of portrait painting. He raised the art both historically and pictorially to a higher level. It was to him we owed our knowledge of the personal appearance of Charles I. and his family. With reference to the collection of portraits, private enterprise had done what the nation neglected. Mr. Cust next referred to the foundation of the National Portrait Gallery through the energy of Lord Stanhope, and the great additions made to it through the influence of the late Sir G. Scharf. He instanced the value of the collection from the historical point of view, and concluded by referring to the great aid afforded by portraits to education and historical research.

In his second lecture, delivered on Monday afternoon, Mr. Cust dealt with the subject of "Portraits as Monuments." He said that if inquiry were made into the strict sense of the word "monument," it would be found that it meant little more than a record or memorial, which should be an incentive to thought. Monuments mostly took form in architecture, sculpture, and painting. As an independent art painting was immeasurably younger than either sculpture or architecture. Having referred to the progress of art in Egypt, Greece, and Rome, he pointed out that Mediæval art portraiture was little used, as the art of that period was completely consecrated to God and the Church. But from the time of the Renaissance onward to the present day the statue and the bust had reigned supreme in monumental art. They were often more than mere portraits; they were works of art, and deserved to rank with the paintings of Titian and Holbein. It was not until the middle of the 18th century that the world of art began to recognise that the art of ancient Rome was a mere transcript from the Greek. One of the most unfortunate delusions which had beset portrait and artistic work for generations both in England and on the Continent had been the belief that Rome, and Rome only, was the Mecca for artists. The complete subjugation of art to the decadent sculpture of Rome was a great misfortune to the human race, and nearly proved its artistic ruin. Unless the marble bust had a place fixed for it, and unless there was some intention for its creation, it was one of the most useless and meaningless things that an artist could produce. Fortunately for London, most of its statues were in bronze. It was difficult for the sculptor ever to produce a real portrait: he could not go beyond certain limits in his art, especially if he were working in marble. As a mere portrait and nothing else the marble bust could seldom be successful. Bronze gave a much more satisfactory statue than marble. Sculpture in terracotta was a branch of the art which seemed to have fallen into a most unnecessary disgrace. By its use colouring could most usefully be brought into play. Portrait statues had before now been made of wood and coloured. Mr. Cust, in conclusion, dealt with memorial, official, and presentation-portrait paintings, pointing to the necessity for the exercise of care in the use of portraits for such purposes.

On Thursday afternoon in last week board schools erected in Nether-street, Beeston, Notts, were opened by Dr. Clifford, of London.

The Gildersome District Council has made application to the Local Government Board for sanction to borrow an amended loan of £2,500, for purposes of sewerage and sewage filtration works.

The subscriptions for the Wilslow parish church restoration fund have reached a total of £1,143. The work of restoring this ancient Cheshire church is now being carried out, the chancel having already been dealt with. The restoration committee have purchased for the use of the parish the ancient Trafford Chapel, one of the most interesting parts of the fabric. This was the property of the trustees of Sir Humphrey de Trafford. The chapel is now being renovated, and it is afterwards to be furnished as a chapel for daily service. All the work is being done under the supervision of Mr. G. F. Bodley, A.R.A., of London.



CONTENTS.

Workmen's Compensation and Employers' Liability 477  
 Model Specifications.—VII. . . . . 477  
 Sanitary Work.—IV. . . . . 479  
 Copying Processes for Reproducing and Duplicating  
 Drawings, Plans, &c. . . . . 481  
 Wrought Iron and Steel in Constructional Work.  
 —XXXVI. . . . . 482  
 The Royal Institute of British Architects . . . . . 483  
 The Society of Architects and Registration . . . . . 485  
 The Protection of Underground Water Supplies. . . . . 485  
 Builders' Clerks' Benevolent Institution . . . . . 485  
 Electric Lighting Notes for Architects.—XX. . . . . 486  
 Mr. Lionel Cust on Portraits . . . . . 488  
 The Building News Directory. . . . . IX.  
 Our Illustrations . . . . . 489  
 Interior of the Church of Sta. Maria, Belem, Portugal 490  
 Building Intelligence . . . . . 508  
 Cheap Paints and Pigments . . . . . 509  
 An Architectural Curiosity . . . . . 510  
 Obituary . . . . . 510  
 Competitions . . . . . 510  
 Engineering Notes. . . . . 511  
 Correspondence . . . . . 511  
 Intercommunication . . . . . 512  
 Legal Intelligence . . . . . 512  
 Parliamentary Notes . . . . . 513  
 Water Supply and Sanitary Matters . . . . . 513  
 Our Office Table . . . . . 514  
 Trade News . . . . . 514  
 List of Competitions Open . . . . . 515  
 List of Tenders Open . . . . . 515  
 Tenders . . . . . 518  
 Latest Prices . . . . . 519

ILLUSTRATIONS.

BONDED WAREHOUSE, GLASGOW.—STUDIES OF ANIMAL LIFE.—"THE LAWN," COGGESHALL, ESSEX.—FONT COVER, COCKINGTON CHURCH.—STATES ASSEMBLY HALL, GUERNSEY.—"WOODNORTON," KING'S NORTON.—"COURT HEY," MOSELEY.—BUSINESS PREMISES, FRIAR STREET, READING.—INTERIOR OF THE CHURCH OF STA. MARIA, BELEM, PORTUGAL.

Our Illustrations.

BONDED WAREHOUSE, GLASGOW.

This building, which will add a striking feature to the commercial architecture of Glasgow, is at present in course of erection in Washington-street, for Messrs. W. P. Lowrie and Co., Ltd., the well-known firm of bonded warehouse proprietors and storekeepers. The warehouse occupies an area of 1,825 square yards, with a frontage to Washington-street of 89ft., and is six stories in height. On the street floor are the blending and bottling departments, washing room, loading banks, Excise office, &c. The remaining flats will be used for storage in bond. The Washington-street front is built with red Corncockle stone, and the north wall with terracotta brick from the works of the Scottish Terracotta and Metallic Co., Ltd., with Corncockle stone dressings. The architect is Mr. Alexander Gardner, 209, St. Vincent-street, Glasgow.

STUDIES OF ANIMAL LIFE TREATED FOR DESIGN.

These National Silver Medal drawings by Mr. John J. Brownword form part of the series of drawings of birds and beasts which we commenced with the opening number of the BUILDING NEWS for the New Year. The present sheet of grandly-plumaged pheasants, the lyre-bird of Australia, and birds of Paradise furnish colour as well as suggestive decorative forms for the artist in applied design. Shown as these graceful creatures are in the accompanying plate, truth to nature is observed, though the draughtsman has somewhat skilfully arranged his subjects for their special adaptation to the purpose in view, and we can only regret that the limitations of monochrome printing do not allow us to give the colours of the originals.

"THE LAWN," COGGESHALL, ESSEX.

A NEW half-timbered front has recently been added to this house, the residence of Mr. G. F. Beaumont, F.S.A., which is a 16th-century building. The brickwork has been executed in 2in. red bricks, specially made, and the doors and windows have moulded Bath stone dressings. The principal entrance has carved stone spandrels and rich mouldings, and linen-fold panelled door. All the timber work has been executed in English oak, the frieze and barge-boards being richly carved in foliated pattern, with the following inscription on scrolls entwined in the foliage of the frieze:—"Hæc Domus anno sexagesimo Victoriae Reginae renovata est." The work has been carried out from the designs of Mr. P. M. Beaumont, A.M.I.C.E., architect, of Maldon, by Mr. Sach, contractor, Coggeshall. The carving is by Mr. W. B. Polley, of Coggeshall.

FONT COVER, COCKINGTON CHURCH.

THIS interesting old carved font-cover in the Church of St. George and St. Mary, Cockington Court, Devon, has recently been restored. It is richly carved, and when needed for baptism, four cants of the octagon open like a tryptich. For many years this cover lay about the church in a number of pieces; but on the Rev. James Henning being recently appointed vicar, one of his first acts was to gather the fragments together and send them to Messrs. Harry Hems and Sons, sculptors, of Exeter, who have carefully put the remains together, and conservatively restored the decayed and missing parts. All the original old hammered iron hinges have been reused.

PROPOSED STATES ASSEMBLY HALL, GUERNSEY.

THIS design was submitted in the early part of last year by Mr. Arthur Ardron, F.R.I.B.A., of 8, Delahay-street, Westminster. Nothing has transpired as to the decision of the promoters, although rumour has it that a second competition is to be undertaken. The principal floor is on the level of the floor of the present Upper Court in St. James's-street. Owing to the considerable fall of ground from the new street to the lower end of St. James's-street, the entrance to States of Assembly Hall is placed at the lower level, and would be approached by a flight of steps leading into a spacious vestibule or hall. Out of this hall are the cloak-rooms for ladies and gentlemen, -to be available more particularly when the assembly hall is used for public meetings, &c. This hall is capable of seating 400 persons, exclusive of the gallery. A rostrum is provided at the eastern end, and behind this, fronting the street, is placed the president's retiring room, with ante-room adjoining. At the opposite end of the large hall provision would be made for forming two committee-rooms by means of movable partitions, as shown by the plan. Communication is given to the present upper court from the corridor, and convenient of access for each floor. A gallery capable of seating about 100 persons is provided. This is placed over the committee-rooms, approached by a wide staircase and corridor. An additional approach and exit is provided from the staircase opposite the St. James-street entrance, and separate lavatory accommodation is provided for ladies and for gentlemen. The hall for the States of Deliberation is placed at the corner of St. James's-street and the New-street, and is designed to give ample seating accommodation for the 50 members. The approach is by a flight of steps in the tower over entrance leading into wide vestibule and inner hall, &c. A lavatory and cloakroom is provided on the same floor, with additional accommodation on the floor above. A large committee-room is shown on the first floor. This room would also be available as a supper-room when required. A small gallery for the use of the public to this hall is provided at one end of the hall, approached from St. James's-street by a stone staircase. On the basement floor provision is made for two sets of offices with separate approach from St. James's-street. These could be let off to solicitors or others without in any way interfering with the public buildings. The caretaker's house is in the basement, under Deliberation hall, and contains parlour, kitchen, scullery, and three bedrooms. The design of the building externally is Italian Renaissance freely treated. The tower is placed over the main entrance in St. James's-street at the highest level of site, so as to be made as conspicuous as possible without entailing extravagant expenditure. A four-way dial clock is shown, and also a small projecting balcony over principal entrance, which could be used for speaking purposes when the elections take place. The buildings would be faced entirely in granite, the mouldings, &c., would be kept as plain as possible in detail. Grey granite to be used for the dressings, and red and blue granite for the general facings; the roofs to be covered with red tiles. The cost of the building was limited to £15,000.

"WOODNORTON," KING'S NORTON.

THIS residence, for Mr. Theodore Pritchett, is situated in the New-road, King's Norton, the site sloping towards the south, the best rooms being placed so as to secure views of the undulating and wooded scenery for which King's Norton is so famed. Besides the three reception-rooms and usual accommodation, there is a billiard-room in the basement. The builder was Mr. Harford, of King's Norton, and the architect Mr. De Lacy Aherne, of King's Norton and Birmingham.

"COURT HEY," CHANTRY ROAD, MOSELEY.

THIS house, for Mr. J. Price (city surveyor of Birmingham) is situated in the Chantry-road, Moseley, and has a pleasant outlook on to the ornamental water and grounds of Moseley Hall. The architect was Mr. De Lacy Aherne, of Birmingham.

BUSINESS PREMISES, FRIAR STREET, READING.

THIS building, now in course of erection, is the Friar-street front of A. H. Bull's (Limited) extensive premises in Reading, which occupies a site extending from Broad-street to Friar-street, and when completed will form an arcade through a well-lighted shop from one street to the other. The upper floors are planned for the accommodation of assistants. The front consists of silver-grey bricks and Bath stone; the shop-front is of red and grey granite, and the roof is covered with Westmoreland green slates. The contract is let to Mr. Margetts, of Reading, and the architects are Messrs. Millar and Nasmyth, of Reading and Oxford.

CHIPS.

The new railway-station at Leigh, Lancs, was opened on Sunday. The platforms, booking-offices, &c., have been completed some time, but the new approach road, owing to a dispute between the town council and the London and North-Western Railway Company, was only connected with Princess-street last week. The station has cost £17,000.

A new Presbyterian church-hall erected at the corner of the Alcester and Chantry roads, Moseley, by the local Presbyterians, was dedicated on Friday night. The hall, which has cost between £1,200 and £1,300, has been built from designs by Messrs. De Lacy Aherne and McRewan, of Colmore-row, Birmingham.

Works for the production of silicate bricks for use in steel-smelting furnaces and kindred purposes have been erected at Brahead, near Baillieston, Lanarkshire, by the Scottish Silicate Brick Company. Such bricks have had to be procured hitherto almost entirely from the Midlands and South Wales.

A new organ, which is in course of erection by Messrs. Lewis and Co., of London, at New-road Congregational Church, Bury, Lancs, is to be opened on Thursday in next week.

Mr. J. J. Colman has purchased from the governors of the Jenny Lind Infirmary the site on which the old hospital stands, and is converting it into a model playground for the children of Norwich.

The churchyard cross at Melbury Bubb, which for many years has consisted of a decayed base only, the shaft having been lost, has just been restored by Messrs. Harry Hems and Sons, of Exeter. The new structure is of Portland stone. From the base rises an octagonal shaft, and on the upper portion in the front is a representation of the Crucifixion. On the reverse side is the figure of the Virgin Mary and the Child Jesus.

This is the 50th year of the existence of Bloomsbury Chapel. It was in December, 1843, that the building, erected by the enterprise of Sir Morton Peto, was opened for public worship. It was the first Nonconformist chapel in London to be built in a prominent position on a leading thoroughfare. It has been decided to thoroughly modernise the building by reseating it, installing the electric light, and providing new heating and ventilating arrangements, and the total cost is estimated at about £2,500.

The well-known City church of St. Mary the Virgin, Aldermanbury, was reopened on Wednesday by the Archdeacon of London, after restoration and reparation from plans by Mr. Eric Collins, architect. The works include the introduction of the electric light.

Of the 94 applicants for the borough surveyorship of Douglas, the following will come before the Committee of Selection for final decision:—Messrs. A. E. Prescott, deputy borough surveyor, Luton; H. J. Weaver, deputy city surveyor, Gloucester; and T. L. Lewis, assistant surveyor, Bristol.

The Andoversford and Stratford-on-Avon Railway Bill has successfully passed through the House of Commons Committee, and now awaits the decision of the House of Lords. The scheme which the Bill seeks to authorise will provide a direct route between Southampton and Birmingham via the Midland and South-Western junction system.

The Libraries Committee of the Liverpool Corporation have adopted plans prepared by Mr. T. Sheldermine (city surveyor) for the new library proposed to be built at the corner of Windsor-street and Upper Parliament-street, Toxteth. The building will be of brick and stone in the Renaissance style. It was resolved to recommend the Council to invite tenders for carrying out the work.

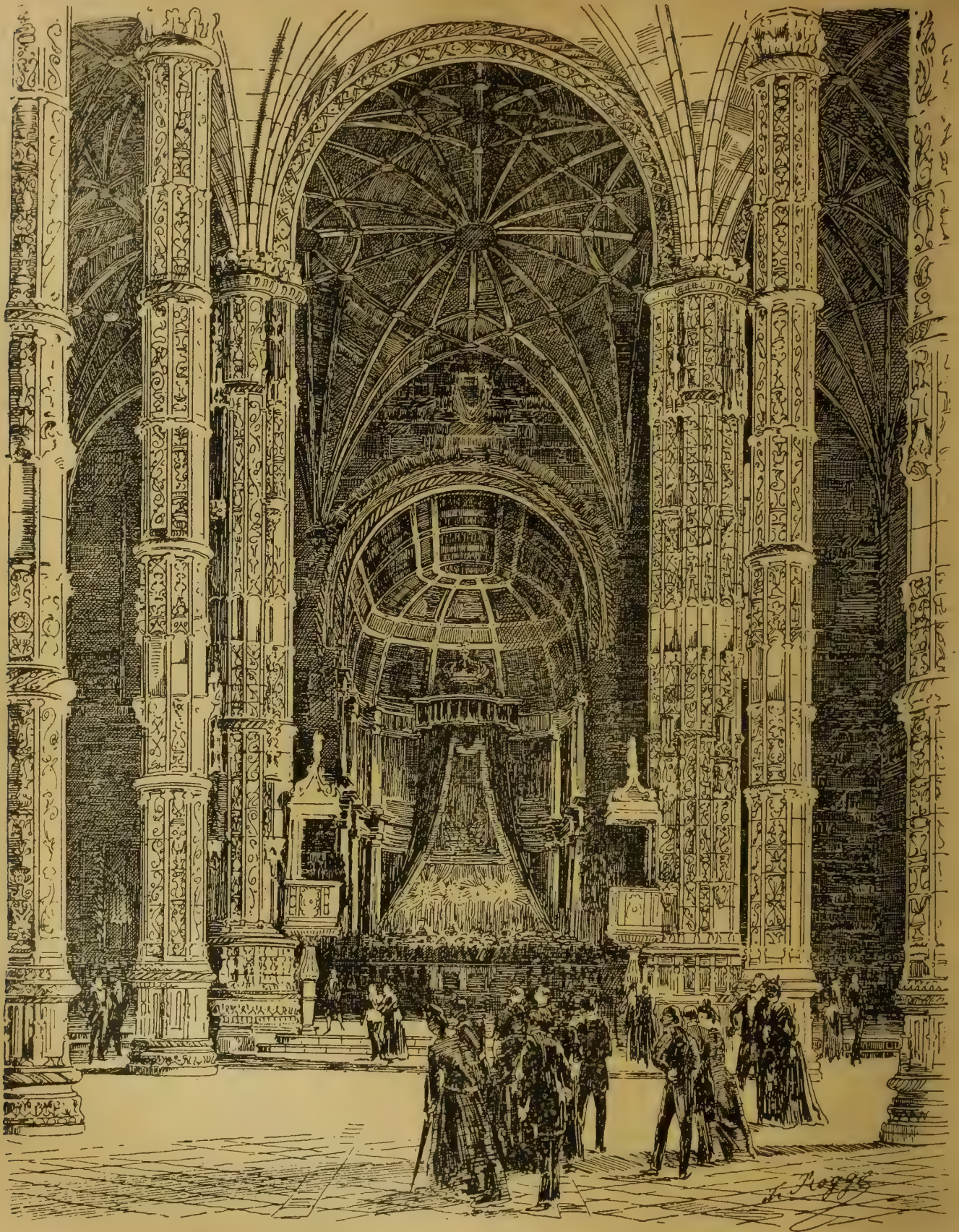

From Oesterr. Monatschrift f. d. öffentl. Baudienst

#### INTERIOR OF THE CHURCH OF STA. MARIA, BELEM, PORTUGAL.

#### INTERIOR OF THE CHURCH OF STA. MARIA, BELEM, PORTUGAL.

THE arcade of this lofty and ornate building is very similar in detail to the well-known cloister in the monastery of St. Jerome, also in the village of Belem, on the outskirts of Lisbon. A drawing of this last-named work appeared in our pages for Jan. 2, 1891, when an account of the building was given. The detail is florid, like that in the cathedral at Braga; but the treatment of the shafts in this church of St. Maria, as will be seen

by the accompanying illustration, seems to afford a suggestive idea for the employment of terra-cotta successfully. The two pulpits give an additional picturesqueness, but the high tester hanging over the altar is hideous and dreadfully out of scale.

The church has been cleared out of many of its old fittings and furnishings, while the repair and so-called restoration of the fabric have not enhanced the historic charm of this interesting building.

A clock-tower is about to be built at Skegness, from plans by Mr. E. Winter, of Egremont.

Memorial stones of a new Sunday-school in connection with Wesley Church, Higher Tranmere, Birkenhead, were laid on Monday at the rear of the chapel. The new buildings will cost £3,600.

At a meeting of the Worcestershire Standing Joint Committee, on Saturday, a tender from Mr. S. Cheese, of Worcester, for the erection of a police-station at Stirchley, King's Norton, was accepted, the amount being £3,050.



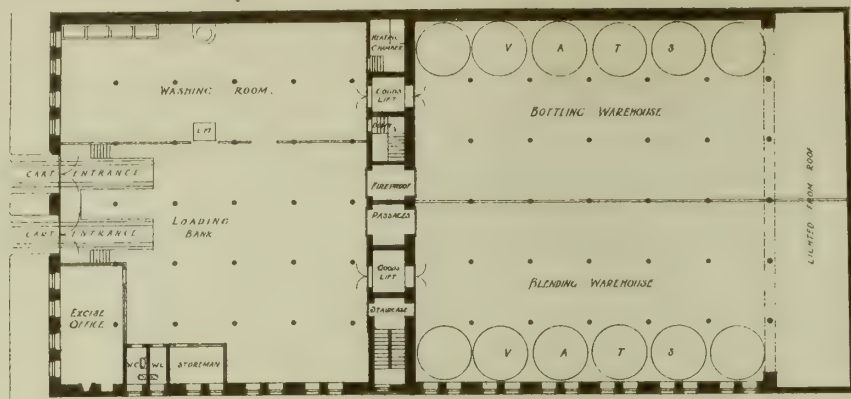

PLAN of STREET FLOOR.



APRIL 8, 1898.

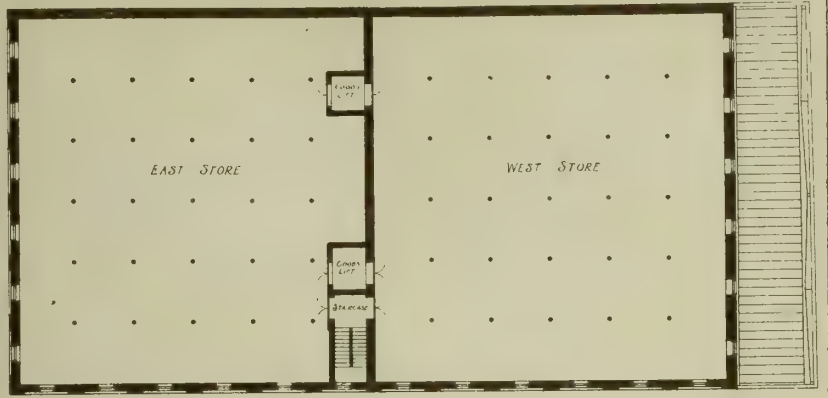

PLAN OF UPPER FLOORS.



Designed and drawn by James Allan & Co. Architects, 6 Queen Square W.

HOUSE, GLASGOW.

ARCHITECT.





THE BUILDING DEWS APRIL 8, 1898.







STUDIES OF ANIMAL LIFE TREATED FOR DESIGN

NATIONAL SILVER-MEDAL DRAWINGS BY JOHN J BROWNSWORD





WOOD NORTON · KING'S NORTON · DE LACY-AHERNE ARCHT



WOOD NORTON PLAN



KING'S NORTON PLAN



COURT HEY · MOSELEY · DE LACY-AHERNE ARCHT



COURT HEY PLAN



MOSELEY PLAN





THE BUILDING NEWS APRIL 8, 1898.

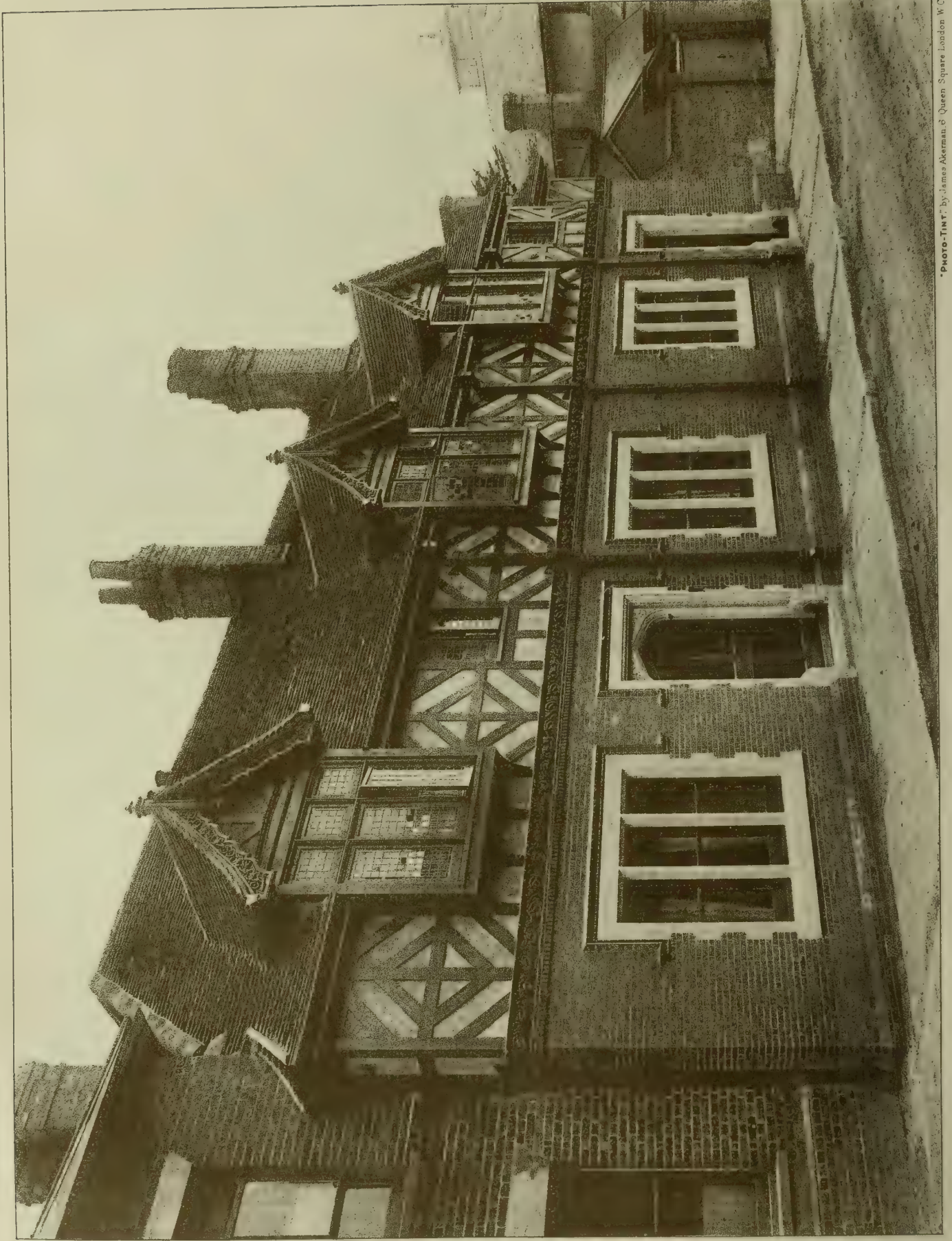

"PHOTO-TINT" by James Akerman, 8 Queen Square London W.C.

THE LAWN · COGGESHALL · ESSEX · P.M. DEAUMONT ARCHT.

THE BUILDING NEWS APRIL 8, 1898.

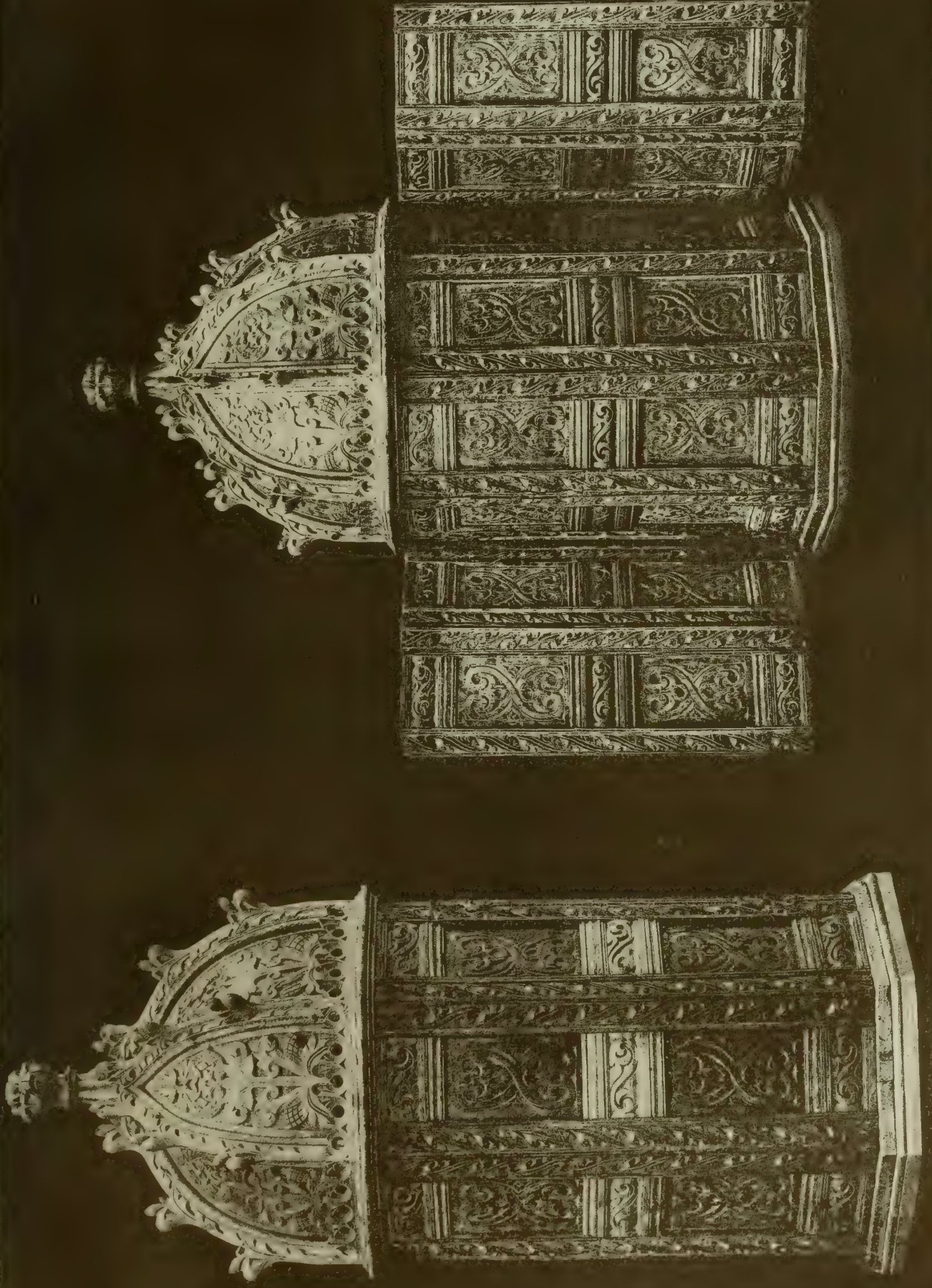

"Photo-Tint" by James Abnerman, 6 Queen Square, London, W.C.

FONT COVER · COCKINGTON · CHURCH · RESTORED BY MESSRS HARRY HEMS & SONS.





THE BUILDING DEWS APRIL 8, 1898.

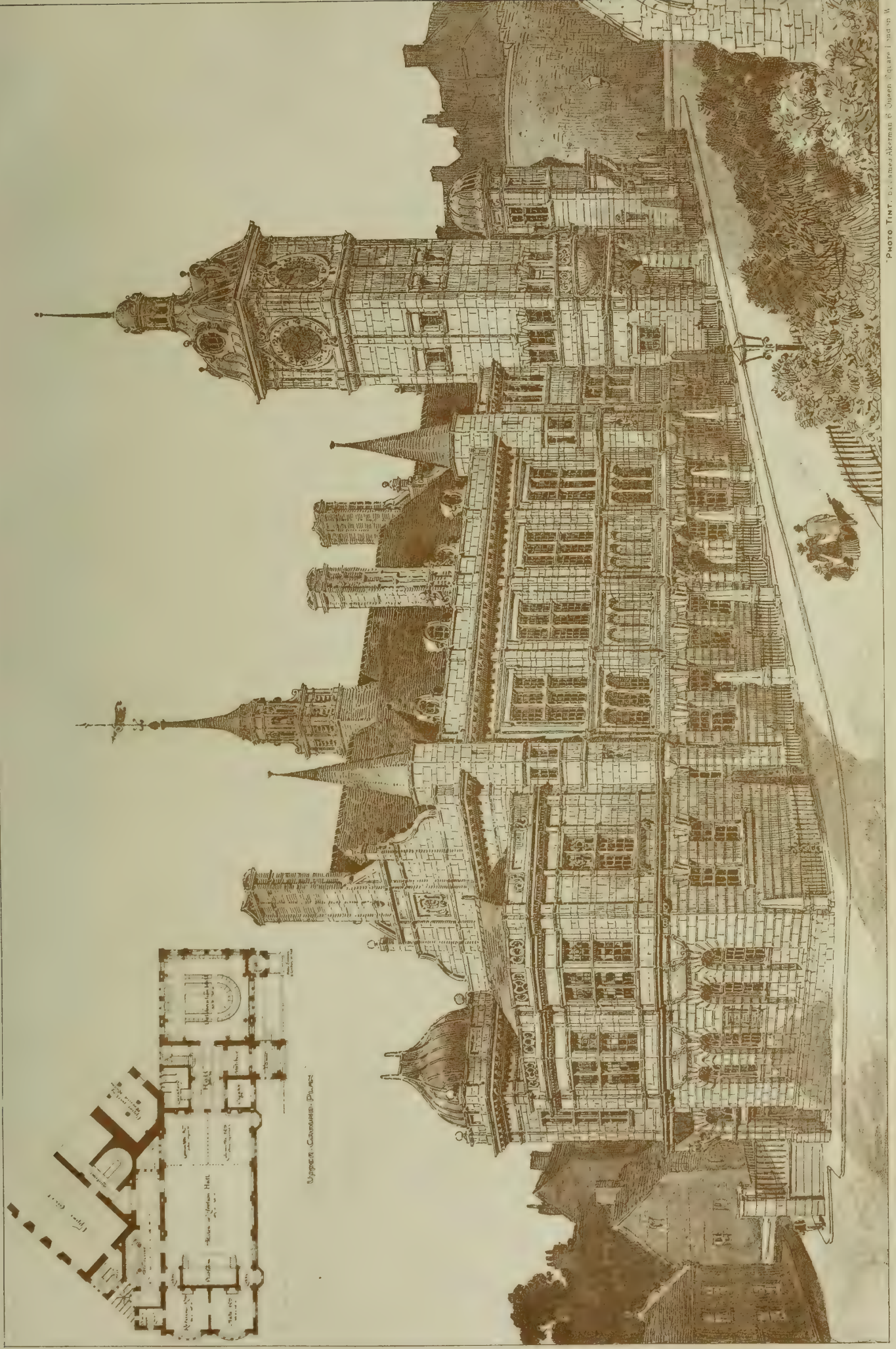

PHOTO TINT. BY JAMES AKERMAN & SONS, SQUARE, LONDON W.

STATES ASSEMBLY HALL & GUERNSEY. COMPETITION DESIGN BY ARTHUR ARDRON FRIBA ARCHT





## Building Intelligence.

**ABERDEEN.**—Preliminary arrangements having been completed, actual work has been commenced this week in the internal decoration of the Trades Hall, Belmont-street, by a series of frescoes. The platform in the hall is recessed from the main hall, and the portion of the wall to be filled in with these frescoes is the part at each side of the platform facing the audience. This part of the wall is formed at each side of the platform into an oblong panel 12ft. high by 10ft. wide, and is surmounted by two smaller panels, the inner panel of each pair being triangular-shaped, occupying the spandrel of the arch over the platform. The artist is Mr. R. Douglas Strachan. The subject chosen for treatment is that of "Labour," and the general idea running through the design as a whole is the progress which labour has undergone. Looking on the left-hand large panel one sees an Eastern group of merchants bargaining over their cargoes, and attended by slaves. In the corresponding panel on the right-hand side is illustrated "Modern Labour." The background, in this case, is largely filled in with mills and factories. A triumphal car, on which the various industries are depicted—agriculture, engineering, textile work, &c., while the arts of music and painting are portrayed in figure. On the left hand of the picture appears a group of workmen—blacksmiths, builders, engineers, &c., engaged in typical occupations; while a group on the right hand are engaged in operations connected with the arrival of a vessel from distant parts. In the four smaller panels figures of "Electricity," "Steam," "Textile Industry," and "Building" are portrayed in monochrome, and the series is completed by the representation, at the spring of the arch, of the lion rampant of Scotland on one side, and the arms of Bon-Accord on the other. Designs have also been drawn up by Mr. Strachan for the decoration of the three large panels in the ceiling of the hall.

**BRADFORD.**—The restoration of the Bradford Parish Church is being proceeded with rapidly, and the citation for the faculty for additional alterations were formally posted on Sunday. It has been resolved to open the recently-discovered "squint" into the church on the north side of the chancel, and that the priest's chamber will be rebuilt as muniment rooms, so that this quaint feature will be preserved in its original form. The total amount now available for the restoration fund, including the Fawcett gift and the Bardsley memorial, is £4,450. The outlay was originally estimated at £6,000; but it will now exceed that sum.

**BURY, LANCS.**—The foundation-stone of a Baptist chapel was laid in Tenterden-street on Sunday. The buildings are in the 14th-century style, and are being carried out with Haslingden Grane bricks and Greetland stone dressings to all windows, doors, quoins, and plinths. The principal front of the chapel has a large gable with central Geometrical window, and the buttresses have turret terminations. At the entrance there is a porch with a flight of stone steps. The chapel is divided into a nave 42ft. by 34ft. 6in., with transepts 52ft. 6in. by 22ft. 6in.; baptistery, 26ft. 6in.; and two vestries, each 16ft. by 14ft. The sitting accommodation provided is for 500 persons. The interior fittings will be of varnished pitch-pine, and the floor will be laid with wood blocks. The roof will be open, and ceiled between the spars, and covered with Welsh slates. The school consists of central hall, 49ft. 8in. by 31ft., surrounded by classrooms each 16ft. by 14ft., with arrangements for enlarging central hall. The interior fittings will be all of pitch-pine, the floor being boarded. The architect is Mr. Thomas Nuttall, of 20, Market-street, Bury, and the building is being erected by Mr. Charles Brierley, contractor, of Fishpool, Bury.

**GLASGOW.**—The new municipal baths and washhouses in Kay-street, in the Springburn district of Glasgow, which have been in process of construction for some time, were opened on Monday. Occupying a site some 2,000 square yards in extent, the new baths are the most completely equipped of those as yet erected by the corporation. They include a swimming pond of the usual size (75ft. by 30ft.), attached to which are dressing-boxes, foot-baths, spray-rooms, &c., at each corner, and a gallery overhead for spectators, the dressing boxes being built on a

new principle, which will preclude the appearance of the rot which has hitherto been so destructive in these establishments; 15 first-class and 13 second-class hot baths for men, and five hot baths for women; whilst the washing-house contains 34 stalls. Instead of the usual timber, the swimming-pond roof is carried by steel principals. Mr. A. B. Macdonald, the city engineer, prepared the plans for the building.

**HOLBECK, LEEDS.**—The third group of public baths erected by the Leeds Corporation were opened on Saturday. They are situated in Holbeck-lane, near the Holbeck railway station. Built of pressed bricks, with stone dressings, the structure, like the baths in Kirkstall-road and Union-street, is in its central portion three stories high, with a one-story wing on each side. The cost is about £8,500. Mr. Walter Hanstock, architect, of Leeds and Batley, prepared the designs.

**KIDSGROVE.**—The want of public buildings at Kidsgrove has been long felt, and the deficiency has been supplied by the urban district council, who have erected a suite of buildings on a site given by Messrs. R. Heath and Sons. The buildings have been erected from the plans of Messrs. Wood and Hutchings, of Tunstall and Burslem. Mr. C. Cope, of Tunstall, has been the contractor, the amount of the accepted tender being £2,034, in addition to which the furniture and fittings will cost nearly £400 and the clock £120, other expenses bringing up the total to about £2,700. The style of the buildings is Free Renaissance. They are of red brick with stone dressings, and are covered with red tiles. The clock tower has been carried to a considerable height. The clock, which strikes the hours, and is by Messrs. Smith, of Derby, has four dials, and will be illuminated at night. The principal room, which is provided with a gallery, will accommodate about 700 people, and there is accommodation for a police-court, council chamber, committee-rooms, ante-rooms, reading-room and library, whilst cloak-rooms for ladies and gentlemen are also provided.

**LEEDS.**—The builders of Leeds are having a busy time. In all the outlying districts row upon row of new dwellings are making their appearance. Indeed, if the present rate of erecting houses continues for another 40 or 50 years, large though the area of the city is, it will be quite built up. A feature of this development is that the majority of these houses are spoken for long before they are ready for occupation, proving that the supply of new dwellings is not in excess of the demand. The fact is, the population of the city is rapidly growing. About sixty more births are recorded every week than deaths, which in itself means an addition to population of over 3,000 a year. The arrivals from other towns are even more numerous. Fully double the number of full removal vans come to Leeds than go out, and, of course, the new-comers have to be housed. At the meeting of the Corporation Building Clauses Committee on Friday, the number of plans submitted for new houses and business premises, and for alterations to existing structures, was 126, establishing a new local record. The guardians of the Leeds Union are about to erect at the workhouse, Burmantofts, new imbecile wards. The pavilion plan has been adopted—a building for males on the one side, another for females on the other side, and an administrative block between, the whole connected by covered corridors. Accommodation for over one hundred patients will be provided. The administrative department will be of one story, comprising receiving and inspection wards, rooms for the medical officer, waiting-rooms, and padded-rooms. Adjoining the kitchen will be the dining-hall, and the two portions allotted to the male and female inmates will be separated by a folding screen. The male and female attendants will have separate mess-rooms, adjoining the kitchen. The pavilions on the right and left will accommodate 14 imbeciles and 11 epileptic patients of each sex on the ground floors, and 34 imbeciles of each sex on the first floors. Each pavilion will be provided with bathrooms, &c. There will likewise be day-rooms. For the attendants there will be, on the second floors of the pavilions, bedrooms and sitting-rooms, with bathrooms. About £14,000 is the estimated cost. The contractor for the excavation, the bricklayer's, mason's, and joiner's work is Mr. Wm. Airey, of Servia-road; for the slater's work, Mr. T. C. Heavyside, Roundhay-road; for the plumber's and glazier's work, Messrs. Braith-

waite and Co., Swinegate; for the plasterer's work, Messrs. Wheeler Bros., Calverley; and for the painter's work, Messrs. Roylance and Horseman, St. Mark's-road. The plans have been prepared by Mr. J. Mitchell Bottomley, Albion-street, and Mr. Prentice is the clerk of works. The ceremony of laying foundation-stones took place last week.

**MACCLESFIELD.**—At the Chester Consistory, on Friday, the vicar and wardens of the church of St. Michael, Macclesfield, were granted permission to make extensive alterations in the church, the cost of which will be about £20,000, which will be defrayed by voluntary contributions. The alterations include the taking down of the nave and aisles of the church and the rebuilding of the same, the lowering of the floor of the nave 12in., the restoration of the Savage and Legh chapels, the formation of the Savage chapel into a morning chapel in lieu of the present one, the conversion of the Legh chapel into a baptistery, the rebuilding of the south porch, the removal of the existing roof over the chancel and the substitution of a new one, the rearrangement of the chancel seats, the restoration of the tower, and the building of a detached vestry.

**WALWORTH.**—The ceremony of opening the public baths and washhouses, which occupy the site of the old dust depot, Manor-place, Walworth-road, took place recently. The building has but one frontage, 284ft. long. The centre portion is three stories in height, having a high-pitched roof, surmounted by a domical turret. At the eastern extremity of one of the two wings is a tower furnished with a clock having three illuminated dials. The public laundry and ladies' swimming-bath are at the extreme ends of the frontage. Renaissance freely treated is the style. The front is faced with red bricks, and the columns, cornices, architraves, corbellings, and other embellishments executed in buff terracotta. The men's first-class swimming-bath has a water area of 120ft. by 40ft., designed to contain 157,000 gallons. There is also a men's second-class bath, 144ft. long by 35ft., possessing a water capacity for 164,896 gallons. Messrs. E. P'Anson and Son are the architects, Messrs. Balaam Bros., the builders, and Messrs. Clarke and Sons, engineers. The vestry agreed to a loan of £33,000 in May, 1894, to carry through the work.

### CHIPS.

The new schools, Llangollen, are being warmed and ventilated by means of Shorland's patent Manchester grates, patent exhaust roof ventilators, and special inlet tubes, the same being supplied by Messrs. E. H. Shorland and Bros., of Manchester.

An inquiry under the Light Railways Act was opened on Friday afternoon at Beaumaris for the consideration of the project to construct a light line between Llanfair, P.G., on the London and North-Western Railway system, and Beaumaris. The estimated cost is £40,000.

At a sale of freehold building plots at Willesden Green, on March 29, an acre and a half of land realised £3,056. A few years ago similar land in the locality was selling at from £500 to £1,000 an acre.

The 25th voluntary pass examination of candidates for the offices of municipal engineers and surveyors to district councils, carried out by this Incorporated Association Municipal and County Engineers, was held at the Institution of Civil Engineers, by the kind permission of that body, on Friday and Saturday, the 1st and 2nd inst. There were 49 entries for this examination, the written portion of which was taken on the first day. The whole of the second day was occupied with the *viva-voce* portion of the examination.

On Saturday afternoon a demonstration took place in Newton Heath to celebrate the opening of the Newton Heath new premises of the Failsworth Industrial Society. The site is at the corner of Oldham-road and Church-street, and has cost £4,000. The buildings have cost about £14,000, and have been designed by Mr. F. W. Dixon, architect, of Manchester and Oldham. They cover an area of 850 square yards.

At a meeting of the creditors of William Harrison Gray, late borough surveyor of Tewkesbury, it was stated by the official receiver (Mr. Charles Scott, of Gloucester) that the unsecured liabilities were £2,355, fully secured £1,160, and partly secured £100. The debts included money-lenders' claims for £327. Against these liabilities were assets consisting of the household furniture and effects, valued at £147, horse, harness, &c., sold at £17. Other small assets had not yet been realised. The estate was left in the hands of the official receiver.

## CHEAP PAINTS AND PIGMENTS.

THE demon Cheapness has entered the hearts of manufacturers of paint and pigments, and, as a consequence, much of the stuff sold for painters' use is spurious. The oil used in grinding the pigment may be a thickened oil or "substitute" for the genuine linseed oil. The thinning vehicle, instead of being honest turpentine, is a make-believe of some hydrocarbon fluid, such as one of the series of turpenes or a mixture in which fluid paraffin largely enters. The pigment itself may be largely adulterated with barytes, gypsum, kaolin, or some other adulterating body which is destitute of all the qualities of a pigment. With such poor materials, it is utterly impossible to produce a first-class job. It is not the writer's intention in the present paper to show how to ascertain the purity or otherwise of the materials used in painting. That subject requires a separate article to itself. What is purposed to do in this paper is to explain the cause of the ill results obtained by the use of bad, impure, or poor materials, and, at the same time, to discuss the chemical reactions that are caused in a coat of paint as ordinarily composed. In our last article on "A Coat of Paint," the actual practice observed in painting a first-class job—on wood—was considered. In that article it was presumed that the materials used were of the best. Let us now consider the case of using inferior (or ordinary) materials, when we shall note many causes of various vagaries exhibited by paints. In the first place, let us consider the knotting compound that has been used. All painters must be familiar with patches of dry paint exhibiting themselves on a wooden painted surface some time after the paint has dried and hardened. This dry patch plainly indicates the position of the knots in the wood, as if the patch were painted in another coloured paint. Such dryness in the coat of paint is caused by the quicker drying of the knotting compound that has been daubed over the knots. If it has been a shellac knotting compound, that will dry at a much quicker rate than the coat of paint, and consequently become dry and hard when the paint is still moist. If the knotting compound has been one composed of litharge and linseed oil, that also will be a very quick-drying compound, and, therefore, by drying at a quicker rate than the surrounding coat of paint, will exhibit its presence in dry patches. Practically there is no remedy for preventing these dry patches, but they can be partially obviated by laying on a little manganese oleate (linseed-oil varnish). When the patches first begin to show themselves, the oleoresinous fluid will partially combine with the knotty compound, and, therefore, by drying with it, cause the knotting compound to dry with a gloss or shine, like the coat of paint. Too much of the linseed-oil varnish should not be used, or it will have the reverse effect to that desired—viz., it will dry with a varnish-like gloss, and so exhibit shining patches.

"Manganese" linoleate (sometimes called manganese varnish, but more frequently called linseed-oil varnish) is prepared by heating raw linseed oil with borate or sulphate of manganese until the fluid has a varnish-like consistence. Such fluid will dry with a tough, elastic, varnish-like skin; but as it does not contain any hard rosin, it will, if laid on paint before the latter is quite hard, more or less sink in or unite with the paint, and thus produce the effect of the paint having been compounded with a varnish vehicle. This linseed-oil varnish, in fact, is one of the best vehicles to use in grinding up a pigment.

Let us now consider the case of an adulterated pigment. White-lead is most likely to be adulterated with barytes, gypsum, kaolin, chalk, or silica. None of these substances have any qualities that fit them for use as a pigment.

*Barytes* is the sulphate of barium. It is obtained as a native product by grinding up heavy spar to a fine powder, or else by precipitating the sulphate of barium by the addition of sulphuric acid, or an alkaline sulphate to a solution of a barium salt. The native variety is of a very crystalline nature, and when ground up in oil is utterly destitute of body or covering power—that is, the compound of oil and ground heavy spar will not hide the colour of the surface on which such compound is spread. It is, in fact, translucent, and therefore worthless as a paint. The artificially-produced sulphate of barium is not quite so destitute of body (it is, in fact, sold and used as blanc fix in water-colour and distemper painting); but in oil it is semi-translucent. The object of using this substance as an adulterant to

white-lead is to increase the weight of the latter so that the (so-called) white-lead can be sold at a cheap or low price. Barytes, native or artificial, is a very heavy body, and consequently a pound of pure white-lead and a pound weight of a white-lead adulterated with barytes will not be equal bulk for bulk. It will be readily granted that as the barytes is destitute of body, that when a comparison is made between a genuine sample of white-lead and one containing barytes, that the latter will not cover so completely a space as large as the pure sample will, or, in other words, loz. of a pure white-lead can be spread out over a larger area than the same weight of a sample adulterated with barytes, because the latter, to enable it to completely obliterate the surface on which it is laid, will require to be laid on in a thicker coat than the former.

In a subsequent article the writer will give instructions for easily and readily making comparative tests of the quantity of pigments used in common painting.

*Gypsum* is also a sulphate, being the sulphate of calcium, and this body is also found as a native product, and likewise produced artificially. The native variety, when calcined and dried, is known as plaster of Paris. In its raw state it is called terra alba. Gypsum is similar to barytes in being destitute of body or covering power, but it is slightly more unctuous, or exhibits a slightly better power of combining with the oil vehicle when ground up therewith. Gypsum is not specifically so heavy as barytes; but it is used for a similar purpose, and exhibits the same effects—viz., want of body or power of obliterating the colour of the surface on which it is laid. Pigments with either of these two bodies mixed with them work livery under the brush when old.

*Kaolin* is a clay or silicate of aluminum. It is the kind of clay that is employed in porcelain manufacture, it having greater unctuousity or power of combining with oil; but it is semi-transparent, and therefore lessens the opaqueness of the white-lead with which it is mixed.

*Silica* is quartz or flint ground up to a very fine powder; it is crystalline, and, therefore, has no power of combining with the oil vehicles, and consequently a mixture of silica and oil is just as effective in covering up the surface of any material as a mixture of oil and sand would be. All the above adulterations are substances which are perfectly inert towards the other compounds of a paint; that is, they do not suffer themselves, nor do they engender chemical reactions in the paint, but as they do not possess any covering power, their presence in the paint is undesirable, and practically a fraud against the purchaser. Anyone who takes the trouble to think over the matter will conclude that it is far better to pay a fair price for a genuine article that does its work well than a lower price for an article which will not cover half as much space. The presence of this body in white-lead, or in any other pigment for that matter, cannot be justified under any pretext whatever.

In the case of chrome yellow, gypsum is a very frequent adulterant—in fact, most manufacturers of these lead chromes maintain that a yellow chromate of lead cannot be produced without the addition of gypsum, or some other white base, in which to precipitate the chromate of lead. The writer emphatically denies this assertion, as he has, and can, always produce any of the commercial tones of yellow lead chromates without the aid of any adulterative body—simply a solution of a salt of lead and a solution of chromate or bichromate of potash or of soda. However, this is not the place to discuss such questions; but as the assertion is so generally made, it may, perhaps, be contended that the presence of gypsum or barytes in yellow lead chromes is not an adulterant. In any case, however, the presence of either of these bodies reduces the staining power, and also the covering power of lead chromes, likewise their unctuousity. But there is one thing to be said in favour of the presence of either of these bodies, and that is that the stability or durability of the yellow chrome is increased by their presence. This is so because chromates of lead readily combine with the linseed-oil vehicle with which they are ground up, and by uniting therewith, form a linoleate of lead (a lead soap, which is soluble in water). Now, the presence of the inert bodies (gypsum or barytes) lessens the formation of the lead soap, and consequently, increases the permanency of the colour. Chalk, whiting, or china clay, however, are positively injurious to the colour, as the alkalinity of the two first bodies chemically reacts

on the yellow chrome, and tend to convert it more or less into a brown colour. Moreover, chalk or whiting will not unite or grind up well with linseed oil, except to form a kind of putty, and thus render the chrome yellow lumpy in working under the brush. Likewise, chalk or whiting, being a carbonate of a metal (carbonate of calcium), it is liable to be decomposed by the action of an acid on the colour, whence the carbonic acid gas compound of the carbonate escapes as a gas, oxide of calcium being left behind. This oxide is caustic and alkaline in its action, and thence causes a darkening of the yellow colour: although a mineral or vegetable acid is not likely, in the ordinary course of events, to come in contact with the yellow paint, yet acids are likely to be brought into contact with the yellow pigment, because as the chromate of lead unites with the oil vehicle to form linoleate of lead, there are certain fatty acids eliminated from the oil which chemically react on the carbonate (chalk or whiting) that is in the adulterated pigment. The presence of a carbonate, or any other alkaline body in yellow lead chromium, is also to be considered in the case of compounding these yellow pigments with Prussian blue to form Brunswick and other green paints; such alkalis chemically react and destroy the colour of Prussian blue, causing the pigment to lose its blue colour and become more or less brown or otherwise changed.

In the case of vermilion the usual adulterant is red-lead or orange mineral; these bodies are used because they are heavy ones like vermilion itself. Their presence of course lessens the vivid red colour of the vermilion; but to restore it, the pigment is brightened up by the presence of eosine or some kindred red aniline dye colour. As red-lead and orange mineral are both good pigments, there is nothing to be said against their use on that point; but, of course, when a man buys an article, and pays the price of the genuine article, he does not want to be palmed off with something inferior, and, therefore, vermilion, adulterated with either of the above bodies is an undoubted fraud.

*Ultramarine Blues* are now produced so cheaply that it does not pay to adulterate the cheaper grades, nevertheless, even the low grade ultramarine are not free from reproach because they frequently contain much free sulphur, owing to the careless or insufficient attention bestowed on making these blues. Now, the presence of sulphur in a paint is one of the most disastrous bodies possible to be there, as it causes all manner of chemical changes in many pigments, whereby they change in colour or lose their stability. The same remark about the presence of sulphur holds good in the case of all those pigments which owe their colour to the presence of sulphur as a component; such colours are vermilion, cadmium yellow, orpiment or "King's" yellow, and a few minor pigments.

*Chrome-greens* that are generally sold are mixtures of yellow chromates of lead and Prussian blues; but the true chrome-greens are oxides of chromium. Opaque oxide is of a sage-green colour, of very good body and unctuousity when ground in oil. The transparent oxide of chromium is a very brilliant, full, rich green, of good body and working qualities; but the method of producing this splendid rich green is too expensive to permit of the pigment being used in common house-painting, while the dull, greyish-green colour of the opaque oxide renders that an undesirable pigment for many purposes of the decorative painter.

In the case of Venetian, light, and other reds, which are oxides of iron, they are seldom pure oxides, but a mixture of sulphate of calcium and red oxide of iron. In this case the presence of the sulphate cannot be looked upon as an adulterant, because it is used in calcining the ingredients which are employed in producing the red oxide, so as to render the production of the red colour easier; this it does, as it enables the salt of iron that is employed to be reduced to the red oxide at a lower temperature than would be the case if the iron salt were calcined alone. The only things to guard against in the red oxide of iron are to make sure that all the sulphate of calcium has become broken down or pulverised, because, if it be in a lump, it will be a drab or buff colour, and this not only materially spoils the colour of the red pigment, but also reacts on the oil vehicle, and causes the paint to work lumpy and go livery. There is one advantage in the presence of the sulphate in red oxide of iron: and that is, it enables the red oxide to be

ground up with an oil vehicle, for if the red oxide were the pure oxide, the union that would take place between the oxide and oil would be so energetic that the paint would be burned or rendered useless. The presence of this sulphate lessens this activity of the oxide on the oil, and therefore its presence is beneficial.

We must leave for a future paper the further consideration of this subject.  
H. C. S.

#### AN ARCHITECTURAL CURIOSITY.

THE following form is being issued for signature by architects desirous of being appointed to erect the Hastings Workhouse, the cost of which is to be about £50,000, and for which an entirely new set of drawings must be made, as the site is a different one:—

TO THE BOARD OF GUARDIANS OF THE HASTINGS UNION.

LADIES AND GENTLEMEN,—I beg to apply to the Guardians to be appointed to act as Architect in connection with the erection of Workhouse Buildings for the Hastings Union, and to state that if appointed I agree to abide by the following conditions:—

1. To adapt the Guardians' plan to provide administrative buildings for 500 inmates, and accommodation for about 370 inmates on the nine acres field, Cackle-street, Ore.

2. To adapt the plans above mentioned, and to prepare such other plans, drawings, specifications, and rough estimates of cost as may be necessary, and will meet with the approval of the Guardians and the Local Government Board.

3. To make all necessary reports to the Building Committee, the Guardians, and the Local Government Board, and to give personal attendance before such Committee, Guardians and Board when so required to do.

4. When the scheme has been adopted by the Guardians, and approved by the Local Government Board, to prepare quantities and estimate of cost, in order that tenders for the execution of the work may be invited, and upon a tender being accepted, to prepare and submit a draft contract for the approval of the Guardians, and to supervise the carrying out of the whole work to its completion.

5. The Guardians to appoint and pay for the services of a clerk of works.

6. My remuneration to be £600, for all services from the time of engagement to the completion of the work and for any extra work that may be necessary. The work of the preparation of the quantities to be an additional charge equal to 1½ per cent. on the contract price, which additional charge is to include the cost of lithographing, &c.

7. In the event of the work not being carried out after the preparation of plans (if the reason be not my own fault) the sum of £100 to be paid to me in full settlement of my claim against the Guardians.

8. The Guardians to have power to determine the appointment at any time before the commencement of the work upon payment to me of the said sum of £100.

9. All new plans, drawings, specifications, and other documents to become the absolute property of the Guardians.—I beg to remain,

Ladies and Gentlemen,  
Your obedient Servant,

The remuneration offered contrasts somewhat remarkably with that paid to the Board's former architect, we believe!

A new graded board school is to be built in Rosendale-road, West Dulwich, at a cost for the building of £15,589.

A special meeting in committee of the Bath Town Council was held last week to consider a letter from Mr. A. R. Holland, proposing to erect on the old slaughter-house site a hotel of the value of £25,000, provided the corporation made a new roadway from Pierrepont-street to Bridge-street, and demolished certain houses belonging to the city so as to open up the site. The meeting was favourable to the scheme, and a committee of nine members was appointed to conduct negotiations with Mr. Holland, and to report to the council.

Colonel Hasted has given his award in the arbitration respecting the cost of maintenance and repairs of main roads within the Flint borough. The amount in dispute between the county council of Flintshire and Flint Town Council was for the three years ending March 1896. The town council claimed the sum of £989 16s. 10d., the county council offered £819 4s. 8d., and the arbitrator has awarded the sum of £938 4s. 10d., the arbitrator's cost (£20 3s. 8d.) to be borne in equal proportions by each authority, and each party to pay their own costs.

Through the enterprise of the Handsworth Urban District Council, the area of the Victoria Park has just been trebled in size by the addition to the original park of some 44 acres. The Victoria Park was established in commemoration of the 50th anniversary of the Queen's Accession, and the extension was intended to celebrate her Majesty's Diamond Jubilee. The cost of the extension has been £17,000. The plans for the laying out of the ground and the designs for the new bridge and boathouse were prepared by Mr. E. Kenworthy, surveyor to the urban district council, and the gardening operations have been carried out under the superintendence of Mr. Mair, the park-keeper.

#### OBITUARY.

THE death is announced, at the age of 67 years, of Mr. WILLIAM DAVIES, builder and contractor, of Gumfreston House, Culver Park, Tenby. Amongst the buildings which he erected may be mentioned Tenby and County Club, board schools at Whitland and St. Clear's, Tenby Wesleyan Chapel, St. Julian's Chapel, Tenby; St. Andrew's School and other houses on the North Cliff, the rectories of Tenby, Jeffreston, and Gumfreston, Tenby Parochial Schools, Somerset Houses, Esplanade; Tenby lifeboat house, the greater number of the houses in Victoria-street, Lancaster Buildings, Tenby Market. He also constructed for the Admiralty Department the coastguard station at Angle, and the silent battery at Tenby. During the latter years of his life he carried out a deal of work for the War Department, including the several large stores at Pembroke Dock, and a two-gun battery at Ferryside. He also held the repairing contract for the War Department from Ferryside to Pembroke Dock, at which latter place he built the new co-operative stores. The deceased, who was twice married, leaves a family of eight—four sons and four daughters. For twelve years he was a member of the Tenby Town Council.

#### CHIPS.

Memorial stones of a new free Methodist chapel were laid last week in Carlton-street, Horninglow, near Burton-on-Trent. The present section of the building will seat 200 persons, and the contract has been taken by Mr. A. Mason, of Burton.

The urban district council of Sevenoaks decided on Monday to raise the salary of their surveyor to £275 per annum.

A discovery of Roman remains has just been made at Dorchester. A few days ago, while digging the foundation for the church house in connection with All Saints, the workmen came upon part of a tessellated pavement and other indications of a Roman villa. A porringer in a good state of preservation was unearthed a few feet below the surface, together with a vase.

On Saturday, the committee of Perth Town Council met with Mr. Westland, of Messrs. Blyth and Westland, engineers, and opened the offers for the new bridge. As it was found they considerably exceeded the probable estimate, they were remitted to the engineers for examination and report.

The interesting old church of St. George's, Douglas, Isle of Man, is about to be taken down on account of the unsatisfactory condition of the building. Some little time ago upwards of £2,000 were spent upon its restoration, but it is now found necessary to rebuild the church.

The rector of Llanrwst has started a movement for the erection of a church house in Conway-terrace, Llanrwst, at an outlay of about £1,000, as a memorial to his predecessor in the living, the late Archdeacon Hugh Jones. The architect is Mr. McIntyre, whose plans show a building to accommodate 400 persons, with classrooms adjoining.

Miss Chattock laid at Solihill, on Saturday afternoon, the foundation-stone of the Victoria Home for Nurses, which is in the course of erection in Beechnut-lane. Miss Chattock is defraying the entire cost of the building, the plans for which have been gratuitously prepared by Mr. J. A. Grew, architect.

The Plynlimon and Hafan Railway, which runs from Llanfihangel on the Cambrian Railway to the stone quarries of Plynlimon, was on Monday formally opened for passenger traffic. The line has been primarily constructed with the object of developing the stone industry of Mid-Wales.

Mr. W. A. Ducat, an inspector of the Local Government Board, held an inquiry at the town-hall, Newport, Mon., on Friday, into the application by the town council for power to put into force the Land Clauses Acts, in order to acquire lands required for the construction of a new road from Corporation-road to Liswerry. It is estimated that the road will cost £3,950, and towards this certain landowners have agreed to contribute £1,685.

Mr. Harry Hems, the widely-known ecclesiastical sculptor of Exeter, is, says the *Times of Natal* of March 10, in Pietermaritzburg, having arrived by the *Avondale Castle*. He will remain there for a few weeks, and then go on to Johannesburg, Pretoria, Kimberley, and Mafeking, returning again to the city some time in April, and leaving for England about the middle of May.

The Derker Schools, the largest property of the Oldham School Board, were opened on Saturday. The buildings replace a privately-managed school, and have been erected at a cost of £20,600. They provide accommodation for 1,524 children. Mr. T. Taylor, of Oldham, is the architect.

#### COMPETITIONS.

ABERDEEN.—The competition for the erection of a new Free Church at the corner of Mid-Stockton-road and Beechgrove-avenue, Mile-End, Aberdeen, has just been decided. The design of Messrs. Brown and Watt, of Aberdeen, has been selected, and that by Mr. A. Marshall Mackenzie, A.R.S.A., also of Aberdeen, has been placed second by the assessor. The selected design is proposed to be built of light Kemnay granite, and the style of architecture is a phase of Early English with Scotch features. A lofty tower with broach spire will rise at the north-west corner, and, attaining to a height of 175ft., will be a conspicuous landmark from many parts of the city and the surrounding country. For a height of 100ft. from the ground it rises as a square tower, having double-light windows with pilasters running up at the angles, while, at the summit above-mentioned, run out four pointed turrets. From this point the tower tapers off in a slender granite steeple, surmounted with a finial. The church is seated for 800 worshippers, and the total cost is set down at £8,000. In the second design, submitted by Mr. A. Marshall Mackenzie, the church would consist of a nave and two side aisles. The choir would be accommodated in a special gallery at the east end, with special provision for the introduction of an organ. The design provided for the accommodation in the church of 820 worshippers, and the seating accommodation in the hall was put down at 361. Provision was made for session-house, vestry, &c. The walls were to be of Kemnay granite, rock-faced ashlar, with picked dressings, and the internal arches and pillars of Corennie granite. The tower was battlemented, and finished by a dwarf spire rising within the parapets of Scottish type. The architect estimated that the probable cost of the whole buildings, including the inclosing walls and railings, decoration, &c., would be £8,000. It is understood that the assessor held the view, in which the committee concurred, that the design could not be carried out for the amount stipulated. The fine proportions of the tower of the church were generally admired, as constituting a commendable departure from the spiral architecture so common in ecclesiastical buildings in Aberdeen. The design is not unlike in general effect to the towers of the cathedral in Old Aberdeen.

BIRMINGHAM: HOLLY MOOR LUNATIC ASYLUM.—In October last the city council of Birmingham received a report from the Lunatic Asylums Committee announcing the completion of the purchase of Holly Moor Farm as a site for a new asylum, and recommending that Messrs. Martin and Chamberlain, the architects of the Rubery Hill and Winson Green Asylums, Warwickshire, and also of those at Bridgend and Carmarthen, be appointed as architects. By 32 votes to 30 the council rejected the committee's report, although it transpired that the nominated architects had prepared sketch plans, and decided to have a limited competition, Messrs. Martin and Chamberlain being one of the six local firms invited to submit plans, and Mr. G. T. Hine, F.R.I.B.A., of Westminster, being nominated assessor. At a meeting of the Lunatic Asylums Committee, on Friday, a report was received from Mr. Hine, in which he gave the preference to plans distinguished by the name "Forward," and the committee unanimously adopted his recommendation. Upon opening the sealed envelopes containing the clues to the authorship of the various plans, it was found that those selected were sent in by Messrs. Martin and Chamberlain.

The urban district council of Cannock have decided that Mr. H. M. Whitehead, their surveyor, be appointed as sanitary inspector at a salary of £135 per year, which, with his salary as surveyor at £165, will make a total of £300 per year.

Considerable interest will be evinced in the trials of motor vehicles for heavy traffic which have been arranged by the Liverpool and District Centre of the Self-Propelled Traffic Association, to take place in Liverpool next month. The object is to arrive at a type of heavy motor-wagon suitable for trade requirements in Liverpool and neighbourhood which shall be capable of economically taking the place of horse haulage. The trials will be over minimum distances of 30 miles on four successive days, but no longer route than 46 miles will be selected. Money prizes of £100, £75, and £50, together with certificates of merit, are to be awarded. Mr. Shrapnell Smith is the local secretary.

## Engineering Notes.

**ALEXANDRA PALACE.**—An electric tramway from the gates of the park in which the Alexandra Palace stands to the entrance to the building is being constructed, at a cost of between £9,000 and £10,000. The length is about one-third of a mile, and the gradient of the hill is very steep. The work of constructing the tramway—which will be the first to be worked by electricity in London—is being carried out by the Imperial Electric Light and Power Company, in conjunction with Messrs. Wandruszka and Co., of Berlin. The tramway will be worked on the overhead trolley system. Each car will have its own trolley, and will be fitted with a couple of American motors of the Steel type, giving in combination from 50 to 60 horse-power. The cars will be of American make and style, and each will be about 40ft. long, and will accommodate 60 passengers. Messrs. Taylor and Field, of Westminster, the electrical engineers who have the supervision of the work, are directing also arrangements for lighting the main hall of the palace by electricity.

**DOCK EXTENSION IN LIVERPOOL.**—The Mersey Docks and Harbour Board Bill, which embraces a scheme of dock extension involving an outlay of £3,562,000, has been passed as an unopposed measure, by a Committee of the House of Lords. The scheme contemplates the construction, on the southern portion of the dock board's estate at Liverpool, of four new branch docks and two new graving docks, with a new deep-water entrance to the existing Brunswick Docks, and, on the northern portion, two new branch docks and one graving dock, with improved entrances. Ten years are given for the completion of the works; but it is the intention of the board to carry them out at the earliest possible moment. When the Bill reaches the House of Commons it will be opposed by the representatives for Ireland on behalf of the Irish cattle-trade, who desire that the dock board should construct, without delay, the new Waterloo Dock landing-stage, at a cost of about £30,000.

**GREAT NORTHERN RAILWAY EXTENSIONS.**—An omnibus Bill of the Great Northern Railway Company came before a Select Committee of the House of Commons last week. Under the Bill extensive powers were sought for widening the existing main line at various points between London and Doncaster, and the construction of a loop line about 20 miles in length between Wood Green and Stevenage by an extension of the Wood Green to Enfield branch by way of Hertford to a point in the main line between Knebworth and Stevenage. This new loop line, which will involve an estimated expenditure of some £1,090,500, will have the effect of placing Enfield and Hertford on a through route between London and the North, and of opening up a district at present poorly served by railways. Another important work, estimated to cost half a million, is the widening of the line at Finsbury Park. For this purpose it was necessary to take a slice of Finsbury Park itself, and here the company met with the unsuccessful opposition of the London County Council. The committee passed the preamble of the Bill, which has been reported for third reading. For the purposes of the works proposed in the Bill, it is intended to raise further capital to the extent of two millions and a half sterling.

**LEEN VALLEY RAILWAY.**—The extension of the Great Northern Railway Company's line in the Leen Valley, Nottinghamshire, from Annesley to Sutton-in-Ashfield, Skegby, and Teversall, was officially opened for passenger traffic on Monday. The line passes through a rich mineral country, and sidings have been made at Pleasley, Silverhill Summit, and Birchwood Collieries. The length of the line now open for traffic, including the colliery sidings, is twelve miles. The contract was let to Mr. Walter Binns, of Bradford, who carried out the greater portion of the work; but the line was completed by Mr. W. H. Hutchinson, of Mansfield. The line will be continued as far as Langwith, a further distance of four-and-a-quarter miles, and the contract for this section has been let to Mr. Hutchinson.

At the last meeting of the urban district council of Buckley, Flintshire, Mr. Edward Astbury, joiner and builder, Buckley, was appointed to the offices of inspector, surveyor, and rate collector at a combined salary of £100 per annum.

### TO CORRESPONDENTS.

[We do not hold ourselves responsible for the opinions of our correspondents. All communications should be drawn up as briefly as possible, as there are many claimants upon the space allotted to correspondents.]

It is particularly requested that all drawings and all communications respecting illustrations or literary matter should be addressed to the EDITOR of the BUILDING NEWS, 332, Strand, W.C., and not to members of the staff by name. Delay is not unfrequently otherwise caused. All drawings and other communications are sent at contributors' risks, and the Editor will not undertake to pay for, or be liable for, unsought contributions.

Cheques and Post-office Orders to be made payable to THE STRAND NEWSPAPER COMPANY, LIMITED.

### TERMS OF SUBSCRIPTION.

One Pound per annum (post free) to any part of the United Kingdom; for Canada, Nova Scotia, and the United States, £1 6s. 0d. (or 6dols. 30c. gold). To France or Belgium, £1 6s. 0d. (or 33fr. 30c.) To India, £1 6s. 0d. To any of the Australian Colonies or New Zealand, to the Cape, the West Indies, or Natal, £1 6s. 0d.

### ADVERTISEMENT CHARGES.

The charge for Competition and Contract Advertisements, Public Companies, and all official advertisements is 1s. per line of Eight words, the first line counting as two, the minimum charge being 5s. for four lines.

The charge for Auctions, Land Sales, and Miscellaneous and Trade Advertisements (except Situation advertisements) is 6d. per line of Eight words (the first line counting as two), the minimum charge being 4s. 6d. for 40 words. Special terms for series of more than six insertions can be ascertained on application to the Publisher.

Front-page Advertisements 2s. per line, and Paragraph Advertisements 1s. per line. No Front-page or Paragraph Advertisement inserted for less than 5s.

Advertisements for the current week must reach the office not later than 3 p.m. on Thursday. Front-page Advertisements and alterations in serial advertisements must reach the office by Tuesday morning to secure insertion.

### SITUATIONS.

The charge for advertisements for "Situations Vacant" or "Situations Wanted" is ONE SHILLING FOR TWENTY-FOUR WORDS, and Sixpence for every eight words after. All Situation Advertisements must be prepaid.

### NOTICE.

Bound copies of Vol. LXXXIII. are now ready, and should be ordered early (price Twelve Shillings each), as only a limited number are done up. A few bound volumes of Vols. XXXIX., XL., XLII., XLVI., XLIX., LI., LIII., LVIII., LIX., LXI., LXII., LXIII., LXIV., LXV., LXVI., LXVII., LXVIII., LXIX., LXX., LXXI., LXXII. may still be had, price Twelve Shillings; all the other bound volumes are out of print. Most of the back numbers of former volumes are, however, to be had singly. Subscribers requiring any back numbers to complete volume just ended should order at once, as many of them soon run out of print.

CEMENT. (Inquire of B. T. Batsford, 94, High Holborn, W.C.)

RECEIVED.—A. F. T.—W. S. A. and Co.—G. N. W.—F. S. and Son.—L. R. P.—M. and K.—E. E.

### "BUILDING NEWS" DESIGNING CLUB.

#### SEVENTH LIST OF SUBJECTS.

G.—A suite of oak furniture and chimneypiece, suitable for the living-room of the Gentleman's Bungalow which formed the subject for the sixth and last competition of our Designing Club. The room is 24ft. long by about 18ft. wide. The chimneypiece is to have a fire 18in. wide. The whole composition is to be 4ft. 6in. wide, and the total height is to be not more than 7ft. 6in. including the overmantel. A good shelf is to be provided, and tiles are to be introduced round the slow-combustion firegrate. The table is to be suitable for a dining-room. One armchair with leather seat, and a sideboard. This latter is to be 6ft. long, and have cupboards and drawers below, with buffet shelves above. The entire height is not to exceed 5ft. Style left to the competitors. Scale for general drawings, inch scale, and details quarter full size. Plans sufficient to show the design, and armchair may be shown only by a view. A view of the buffet is desirable.

DRAWINGS RECEIVED.—"Swan," "Don't Know," "Gib."

## Correspondence.

### FYLDE UNION WORKHOUSE COMPETITION.

To the Editor of the BUILDING NEWS.

SIR,—We have the pleasure to inclose herewith copy of letter sent by us to the Clerk to the Guardians, and shall be obliged if you will be good enough to insert same in your next issue.—Yours faithfully, CRICKMAY AND SONS.

13, Victoria-street, Westminster, S.W.,  
April 5, 1898.

### FYLDE UNION WORKHOUSE COMPETITION.

13, Victoria-street, Westminster, S.W.,

March 26, 1898.

DEAR SIR,—We are very much astonished in finding from the local papers that Messrs. Haywood and Harrison, of Accrington, have been appointed architects for the carrying out of this work, after your intimation to us of

the 11th inst. that the first prize had been awarded to our plans, and this from the public reports appears to be on the ground that Messrs. Haywood and Harrison are local men and we are London men, and not on the ground of the superiority of the plans.

In reference to your conditions of competition, in clause 7 you state:—"The Committee will be advised in their selection by a professional assessor, who will be a Fellow of the Royal Institute of British Architects."

And clause 9 states:—"To the authors of the three designs which, in the opinion of the Committee and the Assessor, are most worthy of it, three premiums of £150, £100, and £50, respectively, will be awarded in accordance with their order of merit. The premium of the architect selected to carry out the work will merge into his usual commission of five per cent. on the outlay of the whole, or any portion the Guardians may decide to carry out."

Relying upon these conditions, we decided to compete for the position of architects, and not for the premiums.

We went to Kirkham, made every inquiry, prepared our designs, and sent them in due course.

We saw by the local papers that an assessor had been appointed, and that he had advised the Guardians to select ours as the most suitable design, and on the 11th March you wrote us follows:—

#### PLANS FOR NEW WORKHOUSE.

"I beg to inform you that the first prize has been awarded to your plans in this competition."

This letter was accompanied by a list of competitors, at the bottom of which it stated:—

"First prize awarded to No. 3. Second prize to No. 13. Third prize to No. 16. The plans will remain staged at the Workhouse, Kirkham, until Saturday, the 19th inst."

We went to Kirkham and examined the plans very carefully and critically, and divesting ourselves as much as possible of prejudice, we came to the conclusion that there was no other set of designs which had entirely solved the problem so completely as we had done.

When at Kirkham, we sent in our names to the chairman and yourself, and found it was not convenient for either of you to see us, and on our return to London we forwarded you references which should have been sufficient to prove our competency and ability to carry out the work.

You may, therefore, imagine how surprised we are to find reported in the local papers of yesterday a statement that the committee, after careful consideration, had decided that Messrs. Haywood and Harrison should be intrusted with the work, and from the report of the subsequent remarks, it appears that the guardians thought they had taken a proper step in appointing a local man.

In our opinion, it would have been perfectly right on the part of the guardians if they had decided in the first place that only local men should compete; but having thrown the competition open and revised their conditions, in our opinion, they are bound by them. And so far as the chairman's statement that Messrs. Haywood and Harrison's plans seem to be the best, we are so satisfied of what would be the decision of the Local Government Board, that we challenge the guardians to send up the three sets of competition drawings to the Local Government Board, and let them, with their full knowledge of the requirements decide as to which set of designs most nearly complies with their stipulations, and who should be appointed as architect, and by their decision we pledge ourselves to be bound; but failing this, we hereby give you and the Guardians notice that we regret to have to say that we feel compelled to consult our solicitors, and to take such steps as they may advise us in order to enforce our rights in this matter.

If driven to it, this will be the first time in the course of a very long practice that we have been compelled to take legal proceeding of any kind; but in this matter we feel so deeply wronged that we shall be bound to vindicate ourselves.

A copy of this letter has been sent to the Local Government Board, the Builder and BUILDING NEWS, and the local papers.—We are, dear Sir,

Yours faithfully,

(Signed) CRICKMAY AND SONS.

The Clerk to the Guardians of Fylde Union.

The Government have just purchased Old Park, Canterbury, for military purposes, and extensive barrack accommodation will be provided on the site.

The memorial stone of new buildings in connection with the Church day-schools of St. John Baptist, Dorset-road, Tuebrook, was laid, on Saturday, by Canon Lester, chairman of the Liverpool School Board. The work is in progress, and being carried out from the plans and under the superintendence of Messrs. Woodfall and Eccles, architects, Castle-street. Mr. W. Knight, of Tuebrook, is the contractor. The cost will be £1,700.

The Public Buildings (Expenses) Bill passed through all stages in the House of Lords without opposition, and on Friday received the Royal Assent. The London Building Act, 1894, Amendment Bill was also read a second time in the House of Commons on Friday night.

On Wednesday week, Col. Slack, the inspector appointed by the Local Government Board, held an inquiry at the Bull Inn, Horn's Cross, as to the application of the Dartford Rural District Council to borrow £4,000 for the buildings at Stone Cemetery. Mr. G. H. Tait, architect, explained the plans.

An important step has been taken, 23 years after the passing of the St. Albans Bishopric Act, towards providing an episcopal residence in the cathedral city of the diocese. Fourteen years ago Lord Grimthorpe purchased a plot of ground close to the cathedral, and he has now transferred it to the Ecclesiastical Commissioners at the price he gave for it. An effort will be made to raise funds to erect a palace without further delay.

## Intercommunication.

### QUESTIONS.

[11929.]—**Useful Items for Builders, Plasterers, &c.**—Will the writer of the above article, in the *Building News* for March 11th last, kindly favour me with a reply to the following query? He would greatly oblige me. Can wax of any sort be dissolved in liquid without of necessity applying heat? I wish to apply it with a brush, in a cold state if possible.—N.

[11930.]—**Brick Ornament.**—A carved piece of brickwork, about 5ft. long by 2ft. high, has to be done. Is it not better to get the work put together and carved in the shed, and then fixed in position? Will some experienced bricklayer reply?—C. L.

[11931.]—**Plumbing Fittings, &c.**—Are there any books which will give the arrangements for fitting up large houses and hotels, and the kind of work, size and thickness of pipes, brass fittings, and other details required?—LEARNER.

[11932.]—**Photography for Architects.**—Is there any guide that will help me in learning the art sufficiently to be able to take views of buildings that I come upon in my cycling or rambles?—T. F. M.

### REPLIES.

[11924.]—**Terracotta Work.**—It is well to joint this material as you would stone. You can have the blocks of any reasonable size, but large blocks are more liable to twist in burning. This journal cannot well select firms to recommend. Terracotta should be set in mortar with a fine joint.—HENRY LOVEGROVE.

[11925.]—**Gauged Work.**—There is, I think, a small book in Weale's series on this subject; but "W. H. H." could get all he requires from some practical bricklayer if he is observant, and has seen building work executed.—H. L.

[11925.]—**Gauged Work.**—There is no treatise specially devoted to this sort of brickwork; but the elementary treatises published by Lockwood and others give particulars and directions for cutting and rubbing and setting. Bricks for this purpose should be rather soft, of even texture, free from holes, &c., so that the cut and rubbed surface may be smooth, and the arrises sharp. The Fareham red rubbers or the Bracknell bricks are probably the best, though there are excellent rubbers made by R. M. and H. Whiting, Faversham. The bricks used for gauged work should be of full size, rather thicker than ordinary bricks, so as to allow for rubbing the beds and joints; the mortar used is lime putty, or a composition of whitening and patent knotting, a mixture of naphtha and shellac, the latter for work intended to be carved. One objection to gauged work is that it is a facing that is not often bonded to the wall, and it is not so durable as ordinary brick, though we know of many buildings in Surrey in which gauged work is used which has stood for more than a hundred years, and the surface is quite hard.—G. H. G.

[11926.]—**Size of Chimney Stack.**—A "Student" will find flues of 9in. square sufficient for his purpose. The brickwork will be gathered together in the usual way of corbelling, or if two breasts carry one stack, these should bear arch between them.—H. L.

[11927.]—**Extra Commission.**—If it becomes necessary for any or all of the work under the contract to be measured, the person measuring is clearly entitled to be paid for his services by the employer. In this case, the surveyor who had prepared the quantities would check the builder's measurements, and prepare a bill of extras, which the architect would examine, and upon it make out his certificate. For this latter service architects rarely charge; but they get the usual commission on the total amount of work executed. If the result shows that the errors were serious, the builder may reasonably expect that his surveyor should be paid by the employer; and although he could not, I think, recover his costs, I have known some allowance made to him. The architect would not, I think, be able to charge for any work done in making up the amount due on each certificate.—HENRY LOVEGROVE.

### CHIPS.

Mr. Alexander McDowall, J.P., timber merchant, of 48, West George-street, Glasgow, died on March 29th, at 5, Glencairn-crescent, Edinburgh.

The Lords Commissioners of Her Majesty's Treasury have selected Mr. Hawes Harrison Turner for the post of Keeper of the National Gallery and Secretary and Accounting Officer to the Trustees.

The Supreme Court of Pennsylvania has sustained the action of the County Court, in refusing to issue an injunction restraining the Capitol Commissioners from awarding contracts for the new Capitol Building at Harrisburg, so that nothing now seems to stand in the way of the prosecution of the scheme.

A memorial to Dr. Arnold has been placed on the north wall of Laleham Church. The memorial is in carved brass, the letters being in relief. The inscription was written by the late Dean Lake, formerly Dean of Durham, who was then the senior surviving pupil of Dr. Arnold. Dr. Arnold lived at Laleham, in a house occupying the position of the present vicarage, from 1819 to 1828.

The Lambourn Valley Railway was formally opened on Monday after inspection on Friday by Col. Yorke, R.E., on behalf of the Board of Trade. The line is 12 miles in length, and extends from a junction with the Great Western system at Newbury through an agricultural district to the town of Lambourn and its racing stables.

### LEGAL INTELLIGENCE.

**DEFECTIVE SOIL-PIPES.**—J. O. Richardson, builder, Albert Works, Peckham, appeared before Mr. Hopkins at the Lambeth Police-court on Thursday in last week to answer to a summons taken out by the Camberwell Vestry for badly executing some vertical soil-pipe drains at the South London Art Gallery in the Passmore Edwards' Technical Institute, Peckham-road. The proceedings were taken out under Section 42 of the Public Health (London) Act. Mr. G. W. Marsden, solicitor to the vestry, prosecuted, and Mr. Geo. Elliott appeared for the defendant, Mr. J. O. Richardson. Inspector Stevenson gave evidence in support of the charge as to bad workmanship, and proved the existence of escapes from the joints of the iron vertical soil-drains which had not been properly caulked with lead. This was confirmed by the Medical Officer of Health, and by Mr. King, a certificated plumber, who has since redone the work for the vestry. Mr. Elliott admitted there was no defence, but the defendant excused himself with the plea that he had only too faithfully followed the specification. Mr. King in his evidence said he had received no other instructions than those contained in the same specification, and that his work had withstood the water-test to the satisfaction of the sanitary authority and also of the architect. No other witnesses were called, and the magistrate fined Mr. J. O. Richardson 40s. and three guineas costs.

**EXTRAS AND PENALTIES.**—The action of Jenkins and Sons v. Randall was tried by Mr. Justice Channell, sitting without a jury, on two days of last week at the Glamorganshire Assizes. Messrs. J. Jenkins and Co., builders, Bridgend, sued Mr. W. R. Randall, solicitor, also of Bridgend, for £771, for balance and extras due on a building contract. In October, 1894, the plaintiffs contracted to build a residence near Bridgend for defendant from designs by Mr. P. J. Thomas, architect, for £1,700. This was called the original contract. Very soon after alterations were commenced, continual changes and additions going on. In April, 1895, the defendant wished to have a large new wing added. This the plaintiffs refused to tender for under the old contract, as they were dissatisfied with the architect; but it was eventually agreed by them to go on, subject to arbitration as to the new wing. Alderman David Jones, of Cardiff, was agreed upon as arbitrator. In the new contract made the defendant would only allow the arbitrator to deal with prices and values, defendant holding that his architect's quantities should rule, so that the award was given in schedule of prices without a sum total being arrived at. When the award was received, the plaintiffs appealed to defendant and his architect for the quantities; but up to the present they had refused to put them in, thus making the award valueless. Plaintiffs made out their own quantities and applied them to the arbitrator's prices, and this showed a balance due to them above what was paid on account of the new wing of £368. Added to this were extras on the original contract of £394. The architect had certified that only £250 was due, and the defendant further deducted from this amount £175 as penalties for non-completion of the building within the time prescribed, paying the residue of £75 into court. The Judge pointed out that as the architect's certificate had not been set aside within the prescribed period the plaintiffs could not now go beyond it, and they were compelled to abandon £140 on this part of the claim. The remainder of the claim was made up of £368 13s. in respect of a wing added to the house under a supplemental contract dated June, 1895. In this case the architect certified for only £168 17s. 3d. The plaintiffs were now suing on the full amount due on both contracts, amounting to £762, while the defendant had paid £75 into court. At the close of the first day's hearing, Mr. Justice Channell ordered the defendant to put in the quantities, and also requested the architect to apply them to his prices. On the second day Alderman Jones attended, and made the amount £237 19s. 7d., as against £168 18s. 3d. admitted by defendant. Plaintiffs abandoned £140, because there was no architect's certificate as regarded this. Defendant claimed £175 for damages for non-completion. In the course of the argument, the Judge said this expensive action had been rather thrown away, as if the figures had been gone through earlier it would not have been necessary at all. In the end, judgment was given for plaintiffs for £412 19s. 7d. and costs, beyond a sum of £75 paid into court. His Lordship ruled that the ordering of extras under a building contract did away with penalties, and disallowed defendant's claim on this head.

**CLAIM FROM PADDINGTON AGAINST THE SCHOOL BOARD FOR LONDON.**—Mr. Under-Sheriff Burchell and a special jury, at Red Lion-square, Holborn, heard on Friday the case of "Pearce v. the School Board for London," a claim for about £6,500 compensation for land taken and houses injuriously affected adjoining Paddington Recreation Ground. It appeared that the School Board acquired a portion of a plot of land which the claimant held on lease from the trustees of the Bishop of London. The

claim was put forward under three heads—the profit rent on the land taken; builder's profit on the houses which would have been erected; and consequential damage to claimant's houses opposite the proposed school. Sir Edward Clarke objected to the claim for compensation for injuriously affecting the houses opposite. The School Board, he said, were not like a railway company working at a profit. If the jury were allowed, after his objection, to assess the damage to the opposite houses, then the Board desired to test the question, and he therefore asked that the verdict should state the sum awarded under each head of claim. The expert witnesses for the claimant were Mr. Wetherall (Messrs. Wetherall and Green) and Sir John Whitaker Ellis (Messrs. Farebrother, Ellis, and Co.); while the experts for the School Board were Mr. Daniel Watney (past president of the Surveyors' Institution), Mr. G. A. Wilkinson (Messrs. Wilkinson and Sons), Mr. Pilditch (Messrs. Pilditch, Chadwick, and Co.), Mr. Leopold Farmer, and Mr. Cooke (surveyor to the School Board). The jury awarded, for land taken £1,650, plus 10 per cent. for compulsory sale £165, together £1,815; for loss of contemplated profit on building, £875; and for injuriously affecting opposite houses, £1,000; a total compensation of £3,690.

**SERIOUS CHARGE AGAINST A STONEMASON.**—At Southwark Police-court, on Friday, John Service, a master stonemason, of Mina-road, Old Kent-road, and Belmont-road, Lse, was charged on remand with obtaining, by means of forged bills, £23 and £95 from Mr. William Jackman, horse-dealer, of Running Horse-yard, Blackfriars. The prosecuting solicitor said there were a number of cases against prisoner, involving a total sum of nearly £1,000. From a document which Detective-sergeant Cox, L division, found in the prisoner's possession, it appeared that the accused made copies of trade bills which he received in the course of business, and got the forged bills discounted by Mr. Jackman. Mr. William George Hornsey, contractor, of West Ham, stated that he gave a contract to Messrs. Bennett and Co. to carry out the mason work in the erection of some new buildings in Dover-street and Rider-street, Piccadilly, and during the progress of the work he gave them a number of trade bills. What purported to be his signature on the bills discounted by Mr. Jackman was a forgery. Mr. John Bennett, master mason, of 32, Gilbert-street, Russell-square, principal partner in the firm of John Bennett and Co., said he received bills of acceptance from the last witness, and handed them over to the prisoner, who had a sub-contract with him. The prisoner was entitled to several thousand pounds under this contract, and he had been over-paid. What purported to be witness's signature on the forged bills was apparently in the prisoner's handwriting. The prisoner was formally remanded, prior to being committed for trial at the Old Bailey, bail being refused.

**SQUABBLE BETWEEN ARCHITECT AND BUILDER.**—At the West Riding Assizes, Stephen Elgar Thorold, an architect and surveyor, of North Ormesby, near Middlesbrough, brought an action against William George Harrison, a builder, of North Ormesby, for damages for slander. The parties were members of the Ormesby District Council, and plaintiff's case was that on two occasions the defendant called him a forger. In the pleadings, defendant denied the slander, and alternatively said if he used the words they were true. The evidence for the plaintiff was to the effect that defendant had accused him of tampering with plans which came before the district council. In cross-examination, plaintiff was asked about the contents of a bill which he wrote in support of his candidature for a seat on the council, for which he was formerly surveyor—a position from which he admitted he was asked to retire. He admitted he spoke of those he was opposing as "barmy on the crumpet." In further cross-examination, plaintiff admitted that he called defendant a prevaricator, and that defendant offered to withdraw his words if he (plaintiff) would take back his. In summing up, his Lordship said the language used by both plaintiff and defendant was a disgrace. The jury found for the defendant.

**CLAIM AGAINST A QUANTITY SURVEYOR.**—At Churston County-court on March 22nd, Marcus Bridgman, contractor, Paignton, claimed £18 11s. of F. W. Vanstone, surveyor to the Paignton Urban District Council, for damages sustained by reason of defects in a bill of quantities supplied to plaintiff by defendant, &c. The claim was made up as follows:—Cost of supplying and laying 290ft. of pipes for the purpose of laying on gas to a lamp, £8 1s.; services by Mr. V. C. Brown, surveyor, £4; balance on £30 lent by plaintiff to defendant, £6 10s. Defendant had paid the £6 10s. into court with costs, and the £4 for Mr. Brown's services was withdrawn. In October, 1896, the district council required certain work to be done in Tower-road, Paignton, for which defendant prepared the plans and specifications. Tenders were invited, and plaintiff was among the contractors who tendered. Plaintiff instructed Vanstone, in his private capacity



as a surveyor, to draw up the quantities. It was for gross mistakes made by defendant in the preparation of the bill and for consequent damages that plaintiff made his claim. A portion of the work was connecting street lamps with the gas company's main, and defendant did not show the distances. The practice was, if no distances were shown in the bill of quantities, to assume that only a few feet had to be laid. As a matter of fact, plaintiff had to lay over 200ft. of gas-piping. Consequently the work cost him more than the £94, the amount of his tender, and he claimed for extras. The district council referred the matter to an arbitrator, who decided that the work was not an extra, as it was in the specification. Defendant's solicitor argued that it was the contractor's place to find out where the main was. His Honour: It was the quantity surveyor's duty to ask where the main was, and to measure it. There is no defence. I have had hundreds of cases of this kind, and know pretty well what is the duty of a quantity surveyor. He has to find out the quantities. I should be doing a very great disservice both to contractors and quantity surveyors if I allowed such a practice to creep into their work. A contractor would never be safe, and quantity surveyors would do their work in a slovenly manner. Mr. Vanstone went into the witness-box and said he had acted in accordance with his usual custom. The finding of the main was never mentioned to him, although plaintiff saw him every day. The Judge: But if the plaintiff had found the main and told you, what would you have done? Witness: I should have done nothing. The Judge: Oh, nonsense. Verdict for plaintiff for £8 ls., with costs.

**FINALITY OF ARCHITECT'S CERTIFICATE.**—BUCKLAND v. TROOD.—In this case, heard by Mr. Justice Darling in the Queen's Bench Division, sitting without a jury, last week, the plaintiff claimed as assignee of Messrs. Garner and Lovelock, a firm of builders. In 1896 Messrs. Garner and Lovelock entered into an agreement with the defendant to make some alterations on the defendant's premises. It was provided by the conditions attached to the specification that the works should be executed to the full satisfaction of the architect, and that payment should be made upon the certificate and at the discretion of the architect. On February 5, 1897, Messrs. Garner and Lovelock assigned to the plaintiff all moneys due or to become due to them under this agreement. The first point in dispute was as to various items of the work, amounting in all to £36 17s. 7d., which the defendant alleged to be negligently executed. As to the second point, the question was whether an item of £106 3s. 6d. for granite-work, executed by a Mr. Whitehead, was due from defendant to Whitehead or to plaintiff's assignors. Mr. Dickens, Q.C., contended, on the first point, that the architect's certificate was final. As to the second point, Whitehead was a sub-contractor under Garner and Lovelock, and had no direct contract with the defendant. Mr. Greene, Q.C., for defendant, argued that in all the reported cases where an architect's certificate had been held to be final, there had been words to that effect in the conditions, which was not the case here. As to the granite-work, it had been agreed by all parties that that portion of the agreement should be cancelled, and the work executed by Whitehead for defendant, and not for Garner and Lovelock. After hearing the evidence, Mr. Justice Darling said that, as to the first point, he could not admit evidence contradicting the architect's certificate. That certificate was final, and the defendant was not entitled to go behind it. On the second point, he had no doubt that the arrangement by which Whitehead took over the granite-work from Garner and Lovelock was entered into with Garner's consent, and on that point the defendant succeeded. Judgment for the plaintiff for £36 17s. 7d. and costs.

**MANCHESTER CORPORATION v. PERKINS, GRAHAM, AND CO., LIMITED.**—An action by the Manchester Corporation against contractors, to recover a considerable sum in respect of alleged defective work in the construction of sewers, came before Sir Benjamin Baker on Monday as arbitrator. Mr. Sutton, in opening the case, said Messrs. Perkins, Graham, and Co. contracted in 1893 to make three sewers in the neighbourhood of Water-street and Deansgate. They were to put in two rings of brickwork; but in many places they only put in one, and the work had been done in dry brick instead of in mortar. The result had been that the corporation had been put to great expense to make the sewers satisfactory. Messrs. Perkins, Graham, and Co. had paid £1,900 into Court to satisfy the claim, but the corporation contended that that sum was totally inadequate. The corporation paid £2,873 2s. 6d. for the part of the work they did themselves, and they further paid Mr. Nuttall, a contractor, £2,563 14s. 5d. for another portion of the work, and there had been left open a certain length of sewer for inspection, and £200 additional would have to be spent in putting that right. These were the sums the corporation were actually out of pocket, and in addition they said that the defendants had been largely overpaid. He supposed it might be said that the state of

things which the corporation complained of was owing to the slackness of the supervision during the illness of the late city surveyor Mr. Allison; but that did not excuse the contractors. It was extraordinary that the corporation officials should have failed to the extent they did. It was estimated that Messrs. Perkins, Graham, and Co. put 300,000 fewer bricks into the sewer than they should have done under the contracts. A claim was made for £610 for cement packing; but when Mr. T. de Courcy Meade, the present city surveyor, proposed to have the sewer opened to see if the cement was there, Mr. Perkins said he would rather forego the claim than that should be done. However, Mr. Meade had the sewer opened, and he not only found that there was no cement, but that there was not the proper quantity of brickwork. Mr. Meade gave evidence in support of the claim, and the proceedings were then adjourned.

**LAMPETER ARBITRATION CASE.**—A long-pending arbitration case between John Watkin Davies, late of Llanybi Mill, and Mr. Wilmot Inglis Jones, of Derry Ormond, has at last been brought to a termination, the arbitrator (Mr. Arthur Lewis) having made his award. The action was brought by John Watkin Davies to recover £191 13s. 6d. for improvements and haulage of building materials towards the erection of new buildings at Llanybi Mill. The defendant had paid £30 6s. 3d. into court. The arbitrator finds that the amount payable to the plaintiff is £29 14s., and directs that judgment should be entered in favour of defendant, with costs, and that the plaintiff should also pay the costs of the arbitrator and a ward.

### CHIPS.

The canopied work over the stalls in the chancel of the parish church of St. Lawrence, Ludlow, which has been placed there by Mrs. Phillips to the memory of the late rector of Ludlow, has now been completed, and the niches have been filled with figures. The work was begun by Sir Gilbert Scott, and his design has been carried on throughout.

The new infectious hospital at Worcester, which has been erected at a cost of upwards of £10,000, was opened on Saturday by the mayor of that city. It is constructed on the pavilion plan, the architects being Messrs. Rowe and Son, of Worcester.

The sanitary committee of the Manchester Corporation has presented a report to the council with regard to the proposed additions to Monsall Hospital. The committee recommend the erection of an isolation block and an erysipelas block, and of additional accommodation for nurses and servants. The cost of the new buildings is estimated at £27,500.

The Duchess of Montrose unveiled a statue of the Queen at Cheltenham College, Cheltenham, on Saturday. It is life-size, and represents her Majesty in full coronation robes, wearing the crown and holding the sceptre and globe. It is the work of Mr. Martyn, of Cheltenham.

Mr. William Henman, architect and surveyor, of Cannon-street, Birmingham, has been joined in partnership by Mr. Thomas Cooper, A.R.I.B.A., a pupil of and leading assistant to Mr. Alfred Waterhouse, R.A.

The water committee of Glasgow Corporation has recommended the acceptance of an estimate of £10,000 by Messrs. Craik and Hendry for making a new driving road on the north side of Loch Katrine. The road, which will be four miles in length, will take the place of an old road at a lower level.

A meeting of Liverpool merchants and ship-owners considered on Tuesday the proposed high level bridge over the Mersey, uniting Liverpool and Birkenhead. The intended bridge would be two miles long, having a roadway 62ft. wide, with one span of 2,000ft., and two others of 1,000ft. each. The headway above high water would be 120ft. The cost of the scheme would be nearly three millions. The engineers, Messrs. Webster and Wood, said that the scheme would pay 7 per cent., and would do for Liverpool what New York's Bridge had done for Brooklyn. The meeting pronounced in favour of some high-level bridge without committing themselves to this particular scheme.

The adjudication in bankruptcy is gazetted of Bernard Joseph Green, Wolverhampton, architect and surveyor.

Considerable alterations are being made to the Memorial Hall, Chesterfield, and special consideration has been given to the ventilation, which will be carried out on the Boyle system.

The members of the Institute of Clayworkers dined together at the Holborn Restaurant on Wednesday evening and the following morning. Some five-and-forty members embarked on the ss. *Fjord* for the annual excursion. Copenhagen is the destination, and excursions will be made to various brick-yards in Denmark and Sweden. The return journey will be made from Esbjerg on Thursday morning next, the 14th inst.

### PARLIAMENTARY NOTES.

**THE NEW GOVERNMENT OFFICES.**—No COMPETITION.—Mr. Akers-Douglas told Mr. W. Allen on Tuesday that it is not the intention of the Government to invite designs for the erection of the new Government offices at Whitehall. The Government has decided to take the responsibility of appointing the architects, and if the question is repeated at a later date, Mr. Akers-Douglas promises further information.—We think a competition would have been the right thing, though we are bound to confess that certain past experiences point the other way. Much will depend on the architect selected. It is said freely that the Government is taking counsel with the Council of the Institute; and in its probable ignorance of the fact that that body in no way represents the architectural profession, it is hardly to be blamed. If something like a job is the result, the Government will, however, have to bear the responsibility.

### WATER SUPPLY AND SANITARY MATTERS.

**MANCHESTER.**—The Local Government Board has written to the Manchester Corporation declining to sanction the proposal of the Rivers Committee to deal with the sewage effluent by the bacteriological method of treatment, as an alternative to the defeated culvert scheme by which it was intended to convey the effluent to the Mersey estuary. The Rivers Committee have consequently decided to recommend the city council to carry out the bacteriological system in spite of the Local Government Board, and borrow the money without the sanction of that body, as they can under the Public Health Act. The estimated cost of the plan proposed is £127,000. The Local Government Board's method of land filtration would, it is said, cost half a million.

The Shipley Urban District Council have decided to invite four architects to prepare designs for new offices, fire-brigade station, baths, stabling, &c., and that they be paid a fee of twenty guineas each, except the successful competitor, who will be paid by commission.

The foundation-stone of Raphael House, Moorfields, was laid on Tuesday by Mr. Raphael Tuck, the founder, some thirty years ago, of the art publishing house of Raphael Tuck and Sons. The new building has been designed in the Renaissance style by Mr. W. Hilton Nash, Mr. Delissa Joseph being consulting architect. The building has a frontage in Moorfields, and return frontages to White-street and Tenter-street.

The new viaducts at Trenance and Gover, on the Cornwall Railway, will be opened as a permanent way in July. They have solid granite piers, with turned arches and spandrels of Staffordshire brick, granite string course, and brick parapet, with granite coping. Messrs. R. T. Relf and Son are the contractors, who commenced building about three years since, under the personal superintendence of Mr. George Westlake, who is at present engaged at Sutton Harbour Works, Plymouth, and Mr. Charles Pickford (Great Western Railway superintendent). In the construction of the viaducts there have been two fatal accidents, both occurring at Trenance.

The directors of the North-Eastern Railway Company have let the contract for the extension of the Middlesbrough Dock to Mr. John Scott, of Cotherton. Two new arms, 700ft. and 650ft. in length, will project westward, and the whole area will be widened, allowing large stretches of wharf area to be added. The entrance channel is also to be deepened along its course and widened on the south side. The plans are those of Sir J. Wolfe Barry. The original dock was opened in May, 1843, when it was only nine acres in extent; in 1849 it was leased to the Stockton and Darlington Railway Company, by whose successors, the North-Eastern Railway Company, it has been since twice enlarged.

A block of publishers' and booksellers' premises, five stories in height, has been built on the sites of Nos. 22 and 23, Warwick-lane, E.C., where for many years there stood an inconspicuous little cobbler's shop and other unsightly premises. The new shop, which has been built for Mr. Charles Taylor, is of Classic design, the front consisting of Portland stone and white brick. The new building, which has an area of 3,000sq.ft., has been erected from the designs of Mr. Walter Starr, architect, of 9, Queen Victoria-street, and the contract, amounting to £6,000, has been carried out by Messrs. Chessum, of the Crown Works, Haggerston.

The new Chelsea Baths at Kensal Town, which have been erected at a cost of £27,000 by Mr. C. Wall from the designs of Messrs. Harnor and Pinches, were opened last week. The building contains two swimming-baths, 80ft. by 30ft. and 60ft. by 25ft.; 51 private baths, of which 16 are for women; a laundry for the establishment, waiting-rooms and offices, and accommodation for the resident superintendent.

## Our Office Table.

THE London County Council considered, on Tuesday, a report of the Improvements Committee on the proposed improvements of Cripple-gate, consequent on the great fire. The City authorities asked for a contribution from the Council towards the cost estimated at £629,000. The committee recommended that the City Corporation be informed that none of the suggested improvements would prove to be of such general advantage to the through traffic in London as to justify the Council in contributing any part to the cost. This was agreed to. It was *nem. con.* referred to the Highways Committee to consider and report as to the practicability of the Council laying and itself working a tramway along the top of the northern outfall sewer embankment from Stratford to Barking; and also what system of traction would be the most suitable and economical for such a tramway, and at what intervals the cars should be run in order to meet the requirements of the public travelling between Old Ford, Stratford, Barking-road, Beckton, Albert Docks, &c. Colonel Rotton, on the report of the Asylums Committee, asking the Council to approve the excess of £7,923 over the estimate in the final cost of the foundation of the Heath Asylum at Bexley, pointed out that the matter was a serious one, because it involved a dispute between two officials—the architect (Mr. Hine) and the works manager (Mr. Adams). The report was adopted without comment.

THE Surveyors' Institution will pay a visit to Manchester on Wednesday and Thursday, the 20th and 21st inst. The use of the Mayor's Parlour in the town-hall has been granted by the Lord Mayor and Corporation. On the Wednesday members will assemble at 10.45 a.m. in this apartment, where they will be welcomed by the reception committee, headed by Mr. John Holden, the provisional chairman of the district, and after an address has been delivered by Mr. Christopher Oakley, the President of the Institution, the following papers will be read and discussed:—"Manchester from 1847 to 1897," by Mr. John Holden; "Lessons from Fire and Panic," by Mr. Thomas Blashill, superintending architect, L.C.C.; "A Consideration of Some of the Present-Day Difficulties met with in a Land Agent's Practice," by Mr. C. P. Hall; and "Notes on the Construction of Town Buildings," by Mr. Howard Chatfield Clarke. In the evening the members will dine together at the Grand Hotel, Aytoun-street. The second (Thursday) will be devoted exclusively to excursions, separate parties being made up for (a) Chester and Eaton Hall, (b) the Manchester Ship Canal, (c) Crewe Railway Works, or (d) Egerton Cotton Mills and the Corporation Sewage Farm. The arrangements appear to have been thoroughly well organised by Mr. Julian C. Rogers, the secretary, and it is expected that the party at Manchester will exceed 200 in number.

A PUBLIC inquiry, under the Fatal Accidents Act, was held on March 31 in the Sheriff Court, Edinburgh, into the circumstances attending the scaffold accident which took place on March 18 at the new North British Railway Hotel buildings, and by which three men lost their lives and several were injured. Evidence as to the stability of the staging which carried the cranes at a height of 60ft. above the North Bridge was given by George and Robert Cousin, of Alloa, the contractors, William Begg, their manager, and John Woodward, the clerk of works, and by many bricklayers and others. It was stated that no expense was spared in the construction, and that in the bracing bolts were used instead of nails. Mr. Thomas Heath, first assistant at the Edinburgh Royal Observatory, showed that at the time of the occurrence the velocity of the wind was 60 miles, and the pressure of 18lb. per square foot. Mr. Cooper, the borough engineer, was called, but counsel objected to his giving any opinion as to the cause of the accident, and Sheriff Rutherford informed the jury that the inquiry was not held for the purpose of ascertaining whether anybody was or was not to blame for that unfortunate event. What the jury had to find was as to the time and place of the accident, the time and place of the three deaths, and the causes of the deaths—not the cause of the accident itself. The jury having heard Mr. Cooper's evidence as to the accident, returned a purely formal verdict that the cause of death was injuries they sus-

tained from being knocked down by the falling, during a gale of wind, of a large steam crane and boiler, with the scaffolding on which they were supported at a height of 63ft.

A DEPUTATION from the Liverpool City Council had a private interview on Monday with the Parliamentary Secretary of the Local Government Board, to seek the sanction by the board to the appointment by the corporation of a bacteriologist to assist in the administration of the Food and Drugs Act. Mr. Russell, in reply, reminded the deputation that the Food and Drugs Act only provided for chemical analysis, the science of bacteriology being much less advanced when that measure was passed in 1875. If the corporation cared to appoint an analyst who was also a bacteriologist, the Local Government Board could sanction his appointment in respect of chemical qualifications; but unfortunately the form of certificate required from the analyst was embodied in the Act of 1875, and it made no special provision for a search for disease germs by means of bacteriological examination.

## CHIPS.

The new fever hospital erected at Thornhills, Clifton, by the Brighouse Joint Hospital Board was formally opened on March 30th. The architects were Messrs. Sharpe and Waller, of Brighouse.

The Eccleshill School Board have adopted plans by Messrs. Kendall and Bakes for enlarging their school at Greengates, at an estimated cost of £1,500. Additional accommodation for 90 children will be provided.

The Liverpool Corporation have accepted the tender of Mr. Charles Burt, of Wellington-road, for carrying out improvements at Newsham Park, at a cost of £7,187. The work consists of laying out as ornamental gardens a piece of land, sixteen acres in extent, which lies on the south side of Gardner's-drive and the west side of Orphan-drive. An avenue, ten yards wide, bordered on each side with trees and shrubs, will be formed, in which four fountains and a band-stand are to be erected.

The organ, renewed and enlarged, of St. Mary's Church, Penzance, has been for several weeks in the hands of Messrs. Heard and Sons, of Truro, and on Thursday evening in last week was again dedicated to Divine worship. The organ was built by Crabb, of Exeter, in 1835.

New Wesleyan Sunday-schools are in course of erection at Boston, Lincs. Mr. W. Greenfield, of that town, is the contractor, and the outlay will be about £2,000.

It has been decided to erect a new technical institute for Selly Oak, and a site has been secured at Bournbrook. The building will include necessary classrooms, reading-rooms, and a central hall for concerts, lectures, &c. Mr. B. B. Hirst, of Birmingham, is preparing the plans, and the cost is estimated at £3,000.

At the Keighley Workhouse Infirmary, a new block erected at the north-west angle of the grounds as a nurses' home was formally opened on March 30. The new building has been planned by Messrs. John Judson and Moore, architects, to accommodate nine nurses. The cost, inclusive of furnishing, will be about £1,000.

At Chelmsford, where rapid progress is being made in various industries, a new building estate is being laid out between Goldlay-road and Lady's-lane, Baddow-road.

The Southport Corporation have purchased by auction of the Scarisbrick Trustees for £18,050 a most central block of freehold property in Chapel-street and Market-passage, free from any restrictive covenants. The contents are about 520 superficial square yards. At present four small shops and a beerhouse occupy the site, and the corporation propose to widen a section of Market-passage—a thoroughfare connecting Chapel-street and Lord-street—and to abolish the beerhouse.

Messrs. F. V. Burrige, A. Evershed, and C. M. Pott have been elected Fellows of the Royal Society of Painter-Etchers and Engravers.

The Select Committee appointed by the House of Commons to consider the merits of the Bill promoted by the Metropolitan Railway Company with the object of obtaining power to use electric traction on their line, and in the meantime to make new ventilating openings at certain points, resumed its investigation on Thursday and Friday. The committee found the preamble of the Bill proved subject to certain conditions laid down as to clauses. The clauses were then adjusted, and the Bill was ordered to be reported. It is understood the Bill will be opposed in the other House.

The Birkenhead Guardians have appointed Mr. George Wharton, principal rating assistant to the Mersey Docks Board, as official valuer to the Assessment Committee, at a salary of £300 a year.

## Trade News.

### WAGES MOVEMENTS.

BIRMINGHAM.—SETTLEMENT OF THE BUILDING TRADE DISPUTE.—In October last the Birmingham Master Builders' Association received notices from the carpenters, plasterers, masons, plumbers, labourers, and scaffolders, demanding an increase of wages, to date from April 2. In the case of the first four named trades the increase asked was at the rate of 1d. per hour, whilst the labourers and scaffolders only demanded a ½d. advance. During the six months disturbing elements have been at work, with the result that the deliberations of the conciliation board up to a week ago were ineffective. At first the masters declared the increases to be unreasonable, but afterwards a promise was made of ½d. advance all round on April 1, 1899. This was rejected. Eventually the masters agreed to concede an advance of ½d. per hour, to come into operation on October 1 next. With the exception of the plasterers, the whole of the operatives agreed to accept this offer, and as the plasterers remained obdurate, the masters decided on Friday to grant the ½d. advance to the plasterers at once. The other advances will date from October 1. Several alterations in the rules will come into operation at once. The dispute is, therefore, at an end, and work is proceeding as usual.

BIRMINGHAM.—The brickmakers of Birmingham have given their employers 15 days' notice of a claim for 10 per cent. rise on moulding and ½d. per hour rise in daywork, and certain other alterations desired in regard to the present conditions of labour in the trade.

COALVILLE.—At a meeting, on Saturday afternoon, at the Red House Hotel, between the master builders and the representatives of the Joiners and Carpenters' Association, an amicable arrangement was come to by advancing the rate of wages ½d. per hour. The rules were signed accordingly, and work was resumed on Monday morning as usual.

GLASGOW.—One thousand cabinet-makers left work in Glasgow on Thursday in last week as a protest against the new regulations dealing with overtime and other questions.

LEICESTER.—The plasterers have obtained an advance of one penny per hour in their wages, a reduction in their hours of labour on Saturdays, and other concessions.—The whole of the carpenters and joiners in Leicester struck work on Saturday on a demand for an advance of ½d. per hour, between five and six hundred men being affected. The men originally demanded an increase from 8½d. to 9d. per hour and a reduction of hours, but were, on the suggestion of the local representative of the Board of Trade, offered by the masters ½d. advance and two hours less per week. They decided, however, to drop the hours demanded and stand out for 9d. They offer to submit the question to arbitration.

SOUTH SHIELDS.—A large number of the bricklayers employed at South Shields came out on strike on Friday for an advance of wages from 9d. to 10d. per hour. The usual three months' notice was given, since which time negotiations have been going on between the representatives of the men and the Master Builders' Association, but have proved futile. Besides the terms for an increase of wages there are also other conditions laid down in respect to the working rules. The masters offered ½d. per hour increase, but this the men have refused, on the ground that in all other parts of the district workmen were receiving 10d. per hour, and in some cases 10½d. and 11d. Other branches of the building trade are also in a disturbed condition. The stone-masons have demanded an increase from 9d. to 10d. per hour, and an 8-hours day or 44 hours per week, and the masters have offered 9½d. and 50 hours per week. The plasterers seek an advance from 9d. to 10d., and the masters have offered 9½d.; while the labourers request an advance from 6½d. to 7½d. per hour.

YORK.—At a large and representative meeting of the operative house-painters of York, held at the Victoria Hall on Wednesday in last week, it was unanimously decided to adhere to their former demand for 1d. per hour advance. It was stated that the wages of the York painters are now only ½d. per hour above those of the labourers in the city.

The plans for the proposed alterations to the Theatre Royal, Preston, prepared by Mr. John P. Briggs, of Ethingam House, Arundel-street, Strand, were approved at the meeting of the town council on March 31st. The pulling down will commence directly after Easter, and the theatre will be opened on Oct. 3.

An interesting ceremony took place at Hull on Friday, on the formal transfer of the undertaking of the Kingston Gas Company to the City Corporation, the latter having purchased it for the sum of £92,500.

# THE BUILDING NEWS

## AND ENGINEERING JOURNAL.

VOL. LXXIV.—No. 2258.

FRIDAY, APRIL 15, 1898.

### CHANGES AND EXTRAS.

IT would be well if the architect, in preparing designs and contracts, contemplated the risks and difficulties attending upon alterations and "extras," and thereby saved himself and his client many heart-burnings. Some people wish to build before even they know what they really want. They employ an architect, it may be, accept his design, and forthwith give him instructions to obtain tenders without discussing with him the plans, or clearly defining what they really want. Their intentions are very obscure, and they apparently employ a professional adviser to assist them in making them clear, or putting before them something in black and white. We believe many people go to an architect simply for this reason, as they have no capacity themselves for realising their ideas. If they can be put on paper and presented in a pictorial way so much the better. Again, there is another large class of people who think they can build without any professional assistance. They have a certain idea of what they want, and imagine they can carry it into effect themselves if only they could get some one to help them in drawing out their ideas on paper or in assisting them in the technical matters. Both these sorts of clients come to grief; the latter sort, having "a fool for their client," often get hopelessly stranded. The "practical" Mr. Brown, or the commercially-minded Mr. Smith, who thinks he can save architect's commissions and buy his materials first hand in the cheapest market, the man who boasts he "knows a thing or two" about building, is often disappointed. Something or other he has omitted, even such a commonplace thing as a damp-proof course or a little care in protecting his basement from dampness or his upper rooms from drenching rains. How frequently the architect has been called in to examine a building erected in this way! A dispute arises about bad drainage—pipes whose gradient is faulty, or joints not properly made. In another case water comes through a basement wall or floor, which could have been prevented by the expenditure of a few shillings at the commencement, but now can only be effected by the rebuilding or pulling-up floors, and the cost of many pounds. Several failures in keeping upper rooms dry have resulted from simply not knowing the rule about a safe pitch for a slate roof, or the necessary lap, to say nothing of hundreds of other mistakes which an ordinary specification would have prevented.

But there are many legal difficulties arising from changes of contract, due often to want of clearness, and sometimes from a change of the client's intentions. A case of this kind was tried at the Glamorganshire Assizes the other day, and was reported in our last issue, where a firm of builders at Bridgend sued a solicitor of the same place for balance and extras, £771, due on a contract for building a residence from the designs of an architect. After this was commenced sundry alterations and additions were made; the defendant wanted to add a new wing, but the contractors refused at first to tender for it under the old contract, as they were dissatisfied, but eventually undertook the work, subject to arbitration, and an arbitrator was appointed. In the new contract the defendant only allowed the arbitrator to deal with prices and values, the architect's quantities ruling. The award was therefore given in a schedule of prices, but no total was arrived at. After the award

was made the plaintiffs appealed to the defendant and his architect for quantities, but they refused to put them in; whereupon plaintiffs made up their own quantities, and applied the arbitrator's prices, which showed a balance due to them over and above the sum paid on account of new wing. Extras also were made up in the old contract of £394; but this exceeded the amount the architect said was due, and a further sum of £175 was deducted as penalties for non-completion within prescribed time, the residue being paid into court. The judge said that as the architect's certificate had not been set aside within the prescribed period, the plaintiffs could not go beyond it, and they were compelled to abandon £140 on this part of claim. As to the wing under the new contract, the architect certified for a sum much less than that of the arbitrator. After some further discussion, the judge said the action had been thrown away, as the figures might have been gone through earlier. Judgement was given for the plaintiffs for £412 12s., and costs, and his lordship ruled that the ordering of extras under a building contract did away with penalties, and disallowed the claim under this head. We refer our readers to the details in the report. But the result of the case is instructive. Here we have a contract which was being continually altered or invalidated by additions and extras which amounted to a considerable sum. The claim for damages for non-completion was disallowed, and the ruling that the ordering of extras did away with penalties is a lesson to all who try to enforce them after making additions and changes. The case is also instructive, inasmuch as the new arbitration clause only allowed the arbitrator to deal with prices based on the architect's quantities. We have here one way in which changes and additions to building contracts may lead to trouble and cost. Half the disputes in building are traceable to alterations and extras, and these are mainly owing to the want of a clear intention on the part of the employer at the onset. As a rule, these alterations and extras release the contractor from his obligation to finish the work by a certain date, especially when the extras have involved more time and have not been assented to by the builder. Numerous excuses for non-performance are made by some builders, such as waiting for a decision of the owner or his architect, halting for working drawings, heavy rains, frost, unfitness of premises to work in, bad soils; but there is no excuse more willingly taken advantage of than the ordering of extra work, or alterations in which extra labour is entailed;—it is so easy for a builder to plead that he has made previous arrangements, or ordered material which cannot be easily set aside without entailing extra cost and time.

### MODEL SPECIFICATIONS. — VIII.

#### ORNAMENTAL BRICKWORK: ARCHES.

BRICK arches demand much care and attention both in the details and specifications. We show two or three sorts of arches in our sketches. Arch cutting and gauged work may be done slovenly or well. How many insufficient camber arches one sees in modern buildings, with badly set-out skew-backs, or the bricks slipping down! Camber arches ought to be set out on scientific rules from a face-mould, and proper bevells obtained for cutting the bricks. Unless the bevells are accurately drawn, the arch is a failure. Of course, this arrangement of arch bricks is not good or constructive, as there is no real arch in it, hence it is called a "scheme." The elliptical arch we give shows two ways of cutting the bricks. On the left side the proper and natural radiation of joints is shown from the three centres or foci of the ellipse, and on the right-hand side is shown a "scheme" in which the joints are

all drawn from the centre of the opening *c*, irrespective of the curvature of the arch. According to this plan the lengths and bevells of each brick vary. This mode of jointing elliptical arches, however, is often followed by bricklayers, as it is supposed to look better for face work. The pointed arch illustrates also two ways of jointing. The left is the natural system in which every brick is of the same length, and is normal to the curve, while on the other side the arrangement is a "scheme." It will be noticed that by the first method the keystone bricks form a wedge in shape, but with a centre joint, as there ought to be in pointed arches. To obviate the wedge-shaped key bricklayers adopt the "scheme" method when the joints are radiated from one centre, and sometimes a key-brick "birdsmouth" in shape is introduced. It is, certainly, not so good to see the apex of a pointed arch formed with a stretcher on one side of the vertical joint and two headers on the other; but this can be avoided by adopting the wedge-shaped key of two bricks.

In specifying these, points ought to be mentioned or a sketch given. Niches are often introduced in ornamental gauged work, and care is necessary in cutting the bricks to insure good bond and to obtain proper bevells. The plan and elevation of this feature to a large scale ought to be given. We also show how a moulded brick archway may be formed. Many suitable patterns of jamb bricks can be obtained, and these can be combined to produce a pleasing arrangement of moulded members. The header bricks bond with the stretchers as shown in plan.

Our next group of sketches show a variety of ornamental gables for doors and windows, dormers and main gables, indicating the courses and jointing. A course of headers and stretchers may be used in the straight members of the lower mouldings, then a course of headers on each of the upper members. Many ornamental variations can be produced by curves, as in designs *c*, *d*, and *e*, and the tympana filled in by carved gauged work, terracotta, or enriched moulded bricks, as in Figs. *c* and *e*. Fig. *f* represents a panel with carved or cast ornament. Fig. *g* is a perspective sketch of a window-head with enrichment in frieze, suitable also for terracotta. In all curved mouldings headers are used.

We have given a few clauses that are applicable to gables and moulded work round door and window openings; and these ought to be accompanied by detail drawings in special cases. Our sketches give a fair idea of the kind of drawing necessary to illustrate clauses of this kind.

We resume clauses for ornamental-brick gauged work. A clause may state generally of the projecting courses, that they are to be all headers, or as directed, and all the courses to be trimmed or rubbed straight and true.

11. *Pilasters*.—The pilasters to entrance to be of approved red rubbers, cut and gauged in cement, and of the projection shown. Or—

The brick pilasters to be cut and rubbed to the form shown, or fluted, and be set in cement or fine putty.

12. *Ornamental Panels or Carved Work*.—The tympana (or frieze panels) to be executed in squared and rubbed red-brick rubbers, set in shellac (or fine putty); the carving to be done to the architect's approval and to his design.

13. *String-Courses and Friezes*.—The string-courses to be formed of two (or three) projecting courses of section as in margin, of Brown's moulded bricks (or Lawrence's purpose-made moulded bricks), set in cement-mortar. Execute cornices (or string-courses) with moulded red bricks according to design, 12in. high and 8in. projection (or in three projections or courses), the second course being enriched (or name particular pattern of brick from Brown's or other catalogue), the other two courses moulded, the courses to be all headers set in fine putty to match facings or rake out and point. The ends to have proper mitres.

## Ornamental Brickwork



## Gables and Ornaments

The following are clauses for gables and panels like those of *c*, *d*, and *f*:-

14. *Ornamental Gables*.—The gable panels shown in *c*, *d*, and *f* to be built in rubbed and gauged facings of Lawrence's best red rubbers, in Flemish bond, set in fine putty or shellac for carving.
15. *Ornamental Gables and Panels*.—Construct the gables of best red Fareham bricks (or red rubbers) laid in Flemish bond, rake joints, and finish with blue ash mortar with neat bevelled joints. The string-courses and curved mouldings to be in three (or two) projecting courses laid as headers in cement, weathered in cement (or the tops covered with two courses of plain tiles, breaking joint in cement, or the outer copings to be covered with 5lb. well secured to brickwork. The pilasters to be formed of moulded bricks projecting from face of work 4½ in. (or 2½ in.), with the strings and cornices returned round them, with moulded mitres at angles (as in *d*). The ornamental finials to be executed from detail with moulded bricks specially made. The voluted curves (in *d*) to be of moulded brick (or courses cut and rubbed) according to detail, the outer cyma moulding and corona being cut to die away on the eye of volute. The pendent pilaster and corbels (see sketch) are to be of gauged, cut, and rubbed brick neatly pointed in putty (or shellac), and carved.
16. *Ornamental Tympana and Friezes*.—Fill in the tympana of gable or panel (*e* and *f*) with brick enriched diapers or ornament in slabs 6 in. (or 9 in.) square, or of required dimensions according to architect's design (or the tympana to be executed in red rubbers carved, set with fine putty joints or shellac), and well grouted at the back in cement; or—  
The frieze over windows (see *g*) to have (6 in. or 9 in.) ornamental bands, or swag ornaments in slabs according to design. Or—
17. *Ornamental Pilasters*.—The panels of brick pilasters to have plastic enrichments in 6 in. (or 9 in.) squares, fixed in cement with neat joints (or to be rubbed, jointed in putty, and carved).
18. *Sills*.—The window-sills (No. ) windows to be of two (or three courses), the upper one of splayed bricks on edge 7 in. or 8 in. projection, with moulded courses below of bricks of section

in margin (or Brown's No. bricks) set in cement to 4½ in. reveals and fitted ends. Or—

The sills to be of red splayed bricks (as design) on edge, all headers in cement to 4½ in. (or 9 in.); reveals, including mitred ends, neatly fitted.

19. *Under-Sills*.—Form under-sills in courses of cut and rubbed best red Farehams or Lawrence's rubbers projecting lin. (or more) from face of work, closely set in putty, and grout in back, and carve lower courses to the design.
20. *Turrets or Oriels*.—The circular turret or oriel to be built in conformity with the plans and elevations, of 14 in. brickwork, Flemish (or old English bond) all headers; in cement mortar. Proper templates to be made to the curve, which are to be approved by the architect or clerk of works. (Octagon turrets or bays should be also set out to a proper bond, and templates prepared to produce accuracy of work.)
21. *Moulded Arches*.—The arches numbered on plan to be constructed of red Fareham rubbers, according to the design furnished, in two or three rings in three recessed members, one behind the other, with moulded (or enriched) bricks of approved section. The rings to be accurately set out and turned and well bonded, and the arrises to be kept true, with fine joints set in cement mortar. Or—  
The arches to be formed of the best red rubbers (or of Brown's bricks, Nos. ) in three orders or rings, as shown in sketch. The rings to be accurately turned and set in lime putty. (If there are capitals, state whether of brick, terracotta, or stone.) If the arch is elliptical or Gothic, add: The arches or rings to be turned accurately with cut or rubbed bricks properly bevelled and set out in shed to the proper centres. (It is best to give the scheme or large-scale drawing of arch, showing centres).
22. *Bed all Stone or Terracotta*.—The brickwork to be well backed up and pinned to all stonework and terracotta, and bed built in, cut and pin all stone sills, lintels, steps, landings, corbels, &c., in cement. Or—  
Neatly bed, cut, and fit all stone or terracotta dressings and arches. The terracotta work is to bond and course with the brickwork.

23. *Pointing Brickwork*.—Rake out cement joints and point brickwork of chimneys (or gables, &c.) with a flat joint in white mortar. Or—

Rake out joints of chimney stacks (or parapets, or fronts) and point the brickwork in ash mortar with a flat joint. Or—

24. *Clean Down*.—Clean down brickwork, including terracotta and stone dressings, and point with a neat weather joint in cement cut on top and bottom.

We have referred to the statutory rules as to brick construction found in the London Building Act, having reference to chimneys and fireplaces (see page 442).

Other important clauses relate to bay windows to dwelling-houses, which provide that no bay window in a street of not less than 40 ft. is to exceed three stories in height above level of the footway, and is not to project more than 3 ft. from the main wall of the building to which it is attached; is not to project within the prescribed distance of the centre of roadway, and is not to be nearer in any part to the centre of the nearest party-wall than the extreme amount of their projection, and is not to exceed in width three-fifths of the frontage of the building fronting the street (see section 73). Oriel windows and turrets are also regulated as to projection and height above level of footway in streets of not less than 40 ft. wide. No part of the projection is to extend more than 3 ft. from the face of front wall of building or more than 12 in. over the public way, and no part of it is to be less than 10 ft. above level of footway, nor within 4 ft. of the centre of nearest party-wall where it overhangs the public way, and it is not to exceed in width three-fifths of the length of wall on the level of that floor.

The rules as to bressummers (section 56) and those relating to the height and thickness

Brick Arches

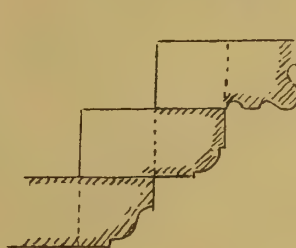
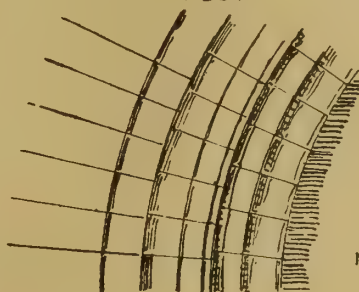
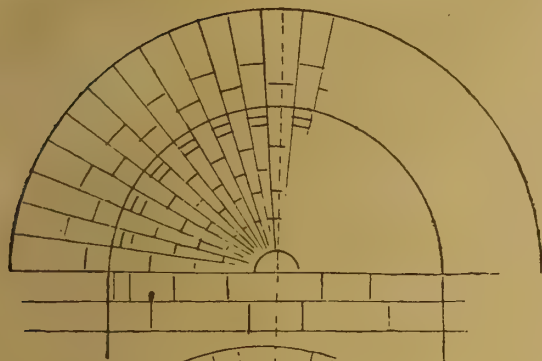
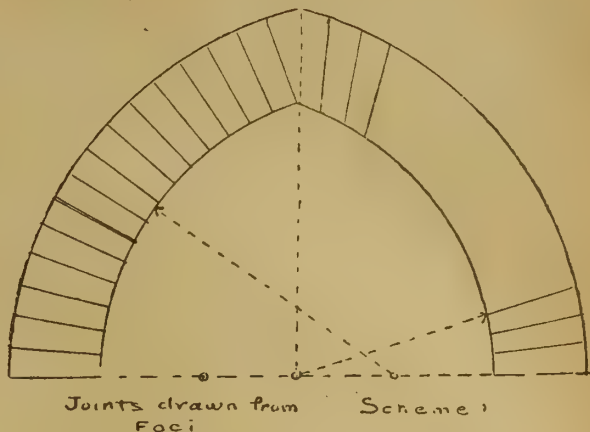
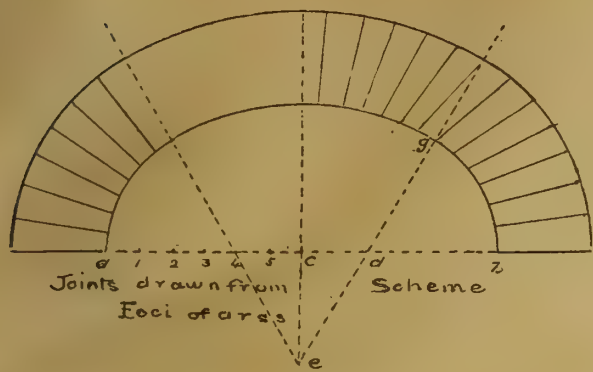

Plan of Jamb

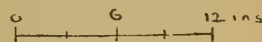

of parapets (57) are important. Rules as to chimneys and flues (64), flues and ovens, chimney-breasts, fireplace openings; thickness of upper side of flue when at a less angle than 45°, arches under public ways (72), we have already given.

“BUILDING NEWS” DESIGNING CLUB.

A SEASIDE CONVALESCENT HOME.

THIS has proved a popular subject, calling forth a considerable amount of good work and no little skill on the part of the competitors. The scheme is not realised perhaps in any one plan so entirely satisfactorily as to justify unqualified approval; indeed the critical reader is little likely to be content with the plans which we have placed first and second, as both of them are too involved to merit description as typical samples of good planning. To make a really simple plan which shall be economical of space and architecturally composed, and at the same time provide for a somewhat complex variety of requirements in a suitable manner, necessarily implies a degree of experience which we do not expect to find usually among the members of a designing club like ours. Consequently, we are prepared to make more allowances possibly than the critic whose lofty eminence sometimes at least may account for the severity of his criticisms. These must be taken in good part by the student, and the same degree of forbearance should be accorded to our remarks in reviewing the plans submitted. It is always so easy to find fault, and the architect cannot expect to be spared more than the painter, the poet, or the sculptor. The engineer escapes blame more than the architect, because the mysteries of construction mystify the ordinary man in the street, and technical expressions, to say nothing of clever-looking calculations, fortify their professors against cheap criticisms. An architect's work, on the other hand, is always associated somewhat directly with questions of taste, and everybody in such things more or less makes a

claim to infallibility. The less qualified the judgment, the more absolutely is it as a rule asserted. There is this to be said, however: that occasionally the want of knowledge on the part of the critic enables him to make a very useful criticism well worth remembering on another occasion.

The conditions under which these designs for a Convalescent Home were prepared, ran as follows:—A Small Convalescent Home for 24 men, by the seaside, on a site overlooking the shore at the head of the cliff, where the land is practically level. The position is exposed, and the building, which is to be built in local coursed stone, must be planned accordingly. The aspect is south-west on the sea-front side. The accommodation is to provide a dining-room, recreation-room, small writing-room or library, two dormitories, a superintendent's residence, comprising parlour, adaptable as an official room, a living-room 14 by 14, or of that area, a kitchen, scullery, and offices. A bath-room with two baths, lavatory with 12 basins; five w.c.'s and urinals, for the use of the inmates; also a boot-room, a cloak-room, and box-room. The whole of the accommodation is to be provided on the ground floor, excepting one dormitory and the superintendent's two bedrooms and two bedrooms for the female servants. A house-yard and small laundry, well separated from the patients' departments, to be provided. The building is to be suitable for 24 men, exclusive of the staff. The roofs to be covered with tiles. The style is to be suitable for stone. Two plans, two elevations, one section, and a view. Scale, 8ft. to the inch for elevations. Plans and section may be drawn to 16ft. to the inch.

We put “Centaur” first, “Dachs” second, and “By Go” third. In arriving at this conclusion we take, of course, the external treatment as well as the plan into consideration, and in a case such as this, where no money limit is named, the appropriateness of the approximate outlay for the purpose in hand should govern the determination of the award. “Centaur” is the best, and his

strongest points are to be found in his elevations perhaps, and in the suitability of the contemplated cost. It would be no difficult task to pull his plans to pieces; as, for example, the attic character of the upper dormitory is a decided defect. The want of lavatories and baths on both floors is to be noted, particularly as the whole of this part of the accommodation on the ground floor is cramped, and inconveniently restricted. It is an advantage to be able to shut off the dormitories from the rest of the house, at the same time securing an approach to the w.c.'s, so that they are available for day or night use conveniently. The superintendent's rooms are not badly placed, though the w.c. on the first floor would have a very conspicuous soil-pipe next the main entrance and up in the air in front of the dormer.

“Dachs” is more ambitious, and more expensive in his scheme, though he gives seemingly a better dormitory with big windows on the first floor. To balance these, however, the small “spare bedrooms” have similar dormers which are out and away too large for these small apartments. On the other hand, for effect sake, the superintendent's bedroom and the matron's room have squat and rather unsuitable windows, and these again are in marked contrast to the linen-room window. The w.c. accommodation is inadequate, and a through draught should be provided by windows in the lobbies between the lavatories and the closet blocks. These last can only be reached through the house, which is a mistake. Another fault is the necessity of patients from the lower dormitory having to go through the main hall and up the staircase facing the front door to reach the bath-room. The dining-room and recreation-room are best in juxtaposition. The bay window to the last-named room is not done justice to in the perspective. “By Go,” the third man, is painstaking, and aims at some spirit in his design. Yellowish paper is contrary to the conditions, which specify white, because drawings on white paper reproduce better. He pays the penalty, for we do not print

his design, as possibly we otherwise might have done. The central garden in his plan is a pretty and useful idea, though on account of the aspect being north-east, it is to be feared the sun would not often reach this garden. The hall is in keeping with the ambitious and hotel-like idea of the arrangements generally, which are clever, but wasteful in passages. The elevation misses success somehow, though we observe an endeavour to avoid elaborate features. This failure may be due to some extent to the ugly splays over the square bays out of which the canted bays rise. The sprawling segmental arches inclosing the shallow verandah are uncouth and ugly. "Pantile" has a sense of the picturesque, but this convalescent home is not one of his best efforts. The building has somewhat the appearance of a farmhouse in the view, and on the road front the central part looks like a tavern. The plan has been sacrificed to the elevations, and we do not like the long corridor. The first-floor dormitory would be a cheerless room facing the north by east, and its windows are very low down. "Saxon" works in the same school as "Dachs," and in some ways his work is better; but we do not like the way in which he mixes up the dormitory traffic upstairs with the servants' apartments. The patients' w.c. is at one end of the landing, and facing it at the other end is the servants' w.c. The superintendent's bedroom is between the two. Externally the design shows taste. The dormitories have cubicles, and downstairs the windows are high up under the eaves. Upstairs the windows are not so clearly delineated, and where they appear on the plan they are left out in the sectional elevation, the only place where they ought to show. "Petticoats" has one of the best plans on the board, and it looks rather practical; but we are unable to express approval of his elevations. They are so unshapely, and in the view might be mistaken for a cricket pavilion. The belvedere tower is a good idea, not very effectively realised. "Caedmon" has a compact plan, with a quaint, unsophisticated elevation marked by an odd bay, which attracts our attention. The entrances to the house are bad, too cramped, and in both cases too much connected with water-closets. The interior arrangements are very mixed, and not good. "Bernard" shows an original endeavour, overweighed with circular forms in plan, clever in a way, and uncommonly ingenious, though carelessly completed; his inky view would ruin any chance of success. The sea-front looks like a salt-water bath house. The plan is crowded, and not convenient. "Mantom" (H. R. C., we cannot really read your motto) has a quiet design and workable plan, making the building in appearance more like a school. The sanitary arrangements are better than in most of the other schemes, and both floors have lavatories, &c. The bathroom is on the upper story. The drawings are carefully and properly worked out; but they are not very attractive. "Ivy" sends an odd design with a pavilion at either end of a long line of roof. It is drawn rather crisply; but the plan is ill-considered, and crude in its parts. The stairs leading up to the servants' bedrooms rises almost immediately outside the doorway opening into the men's ground-floor dormitory. This is not suitable isolation. "Hotspur" has a plan with several points of merit. The S.W. front is partly in half-timber work, but on the N.W. side a sort of Scotch style in stonework is adopted. The angle-nook in the inner hall would serve no purpose, and the plan generally would be improved by simplification. "St. Catherine" comes next, and has a dormitory in the roof with dormers, after the manner illustrated in the design placed first. The superintendent's living-room is located as far away as possible from the kitchen and administrative part of the premises. "Swan" cannot say his design is graceful, and the upper dormitory, leading out of the lower one, is most objectionable. "Olliwops" draws in outline a design which is not devoid of meritorious simplicity; but we do not praise his plan. The main passage of the house gets its light and ventilation on one side, at any rate, from the lavatory and urinal department. This is not nice. "Notts" has a squat porch to the main entrance leading into a square hall, in front of which is the dining-room, so that all the food from the kitchen necessarily must be brought into the entrance hall. "Alesia" sends a bird's-eye view which hardly helps his chances. Both dormitories are badly planned, with two beds in the centre. Each has a nurse's bedroom attached,

and also a bath-room, lavatory, &c. The dining-room is not well placed with regard to the kitchen. "Tee Square" marks his design by a square dwarf tower. The composition is quaint and unusual, but the drawings are thin and poor. "Rydal" comes next, then "Klondyke" (whose view is only partly done in pencil), "Cobden," "Giaour," "Crow," "Lany," "Derige," "Strax," "Suburb," "Angler," "Stanley," "Nowhere," "Gib" (a very neat and thoughtful design falling short of the success it aims at). "John Bull" is neatness itself; but his scheme is not well contrived, and the domestic arrangements are too intimately intermingled with the patients' rooms. "Don't Know" should improve his draughtsmanship. The triangular Gothic porches against the canted dormitory and dining-room are strangely out of place. "Oak" has much to learn, and so has "Chuckle," who ought to draw better than in this careless sheet. The last plan is marked "Chess."

#### WROUGHT-IRON AND STEEL IN CONSTRUCTIONAL WORK.—XXXVII.

(CONCLUDED.)

LIGHT buildings of steel have the advantage over those of masonry, of cheapness, and rapidity of erection. A temporary or a permanent building can not only be erected at little cost in this material, but it can also be pulled down and re-erected elsewhere at any time. This is a consideration in the case of growing firms, enabling them to locate their shops in different localities from time to time, as may seem most suitable for the work in hand. The deep and broad foundations necessary for a superstructure of masonry are not so essential for light iron structures. Attachments for machinery are also made much better to iron than to stone or brick. There is one important use of steel, of which we know nothing in this country—namely, as a material of which the skeletons of tall buildings are constructed. These are built in America from 12 to 20 stories high, attaining a height in some cases of 280ft. to 300ft. In these the masonry is like that on our own Tower Bridge, simply a facing or covering for the gaunt anatomy beneath; for the joists, columns, channels, angles, tees, and gussets which are built directly upon the foundations upwards, and which sustain the whole of the stresses due to weight and wind pressure. These buildings are the work of specialists, both architects and engineers, since the problems to be faced are of a unique and special character. Maximum of space, with minimum of weight, have to be duly balanced, and the provisions for the elevators, and the motive power by which they are operated have to be made. Ten or a dozen elevators or more will be operating in a single large building. Rapidity of erection also is often a problem to be seriously considered where land is costly and rents high, while the probability of future modification or extension may have to be borne in mind. Without steel, and without the modern quick elevator, these tall buildings could not have been economically constructed.

The value of steel as a material for structural purposes is not to be measured alone by the massive work which has been considered. In two other directions developments have taken place which would have been impossible if iron alone had been available. Steel ropes and expanded metal have each a future, and are destined to exercise immense influence in the construction of public buildings and engineering works. Without wire rope many of the great engineering feats would have been more costly and difficult than they have been. The Sukkar Bridge over the Indus is one case only in point. It has a span of 820ft., and a breadth of 79ft., and it was erected by wire rope supplied by Messrs. Bullivant.

Though expanded metal has been only about nine years before the public, its uses and applications are already very numerous. Both as a binding element of strength in concrete work, and as a protective agent against fire, its merits are beyond question. Yet metal could not be stamped and expanded if there were no mild steel. Wrought iron could not stand such stretching without fracture, and though the best iron might be expanded to a very small mesh, the continuity of the fibre would be short in one direction, and the strength in the direction of fibre much less than that of steel. In the protection of buildings from fire

this material will probably play an important part, for it is not only in itself fire-resisting, but it is not open to the objection of being subject to expansion under heat, like continuous sheets, because the reticulated form permits of local expansion, and the concrete or cement is, therefore, not so liable to flake off. It is consequently a suitable material for incasing cast-iron columns, steel joists, and girders, and for the bases of floors and party walls. The very great increase in strength which it affords to concrete arches is remarkable. It affords an excellent binding element or key for cement enrichments, becoming at once a fireproof protection, and a basis for ornament. It is not possible to say to what extent this metal may not ultimately be employed. Wherever a binding material is required in concrete and cement, the qualities afforded by this must give it precedence of the older ones. Interwoven with wire studs, it makes a practically solid structure without the drawbacks incidental to the use of solid sheets of metal. It is made in sheets up to 8ft. square, in various thicknesses, and in meshes from  $\frac{1}{2}$  in. to 6 in. The thicknesses range from 24 B.W.G. to  $\frac{1}{2}$  in. The expansion is from two to twelve times the original width of plate, according to the size of mesh and width of strands. The numerous applications of this metal in buildings are already tolerably well known, and need not be further dealt with here. It may be noted that expanded metal, and the machines for making it, are American inventions.

The weights of iron and steel work afford a rough basis upon which estimates are made. To go through the detail weights of a large structure seems a very formidable task; but it is facilitated by the use of tables which give weights of sheets, plates, and of the various sections. Then, further, it is often possible to cover a large quantity of detail in a short time when there is much similarity or repetition of outlines and sections. There is a knack in getting out estimates quickly, previous experience being a very sure guide. Parts which are similar, even though not identical, afford a sufficient aid to the making of approximate allowances, greater or less in extent. Formulae are given with a view to facilitate such calculations, but they have to be used with caution, since they mislead if applied in cases which are not absolutely identical. The only safe rules are those which deal with the details of a structure instead of a structure as a whole. And since built-up work is nearly always built wholly of sections which have uniform cross-sectional areas, and as these are repeated many times, the safe way is to go through a little detail, taking a given section, and multiplying the weight of that by the number of similar ones.

Trautwine gives a simple rule for weight. In beams of wrought iron, of any cross-section, provided it be uniform—

The weight per lineal yard in pounds = area of cross section in square inches  $\times$  10.

And—

The area of cross section in square inches = weight of beams per lineal yard in pounds/10.

It is not safe to base an estimate on weight alone except with reference to a previous similar structure. That would be very misleading, notwithstanding that price is often given at so much per ton. But prices must vary exceedingly with the quantity of work involved and the quality of the workmanship. The first named varies with design, so that structures which are built up in a simple fashion may not cost half as much as others of the same weight, built up in a different way. The details of the design of a bridge depend partly upon the cost of material and the weight. Thus in a very long bridge there would be greater reason for the saving of weight than in a short one, and the aim would be to build up its members of sections, which would give the minimum of cost and of weight, even though it might happen that the cost of labour might be somewhat increased.

In designing work of an extensive character, it is desirable, for several reasons, to adopt uniformity in detail as far as is consistent with considerations of structural suitability and of strength. It will often happen that this will involve some redundant strength, or some slight redundancy of details in certain sections. But from the point of view of economy in cost, and of facility of erection, such a course is politic. The work of manufacture is facilitated by the introduction of repetitive details, and better workmanship is often possible, because it pays to make special

appliances and rigs-up for the purpose of improved manufacture of large quantities of identical parts.

The inspection of workmanship differs in some respects from the testing of materials. The latter can be carried out by a man who has little acquaintance with the former. To judge of workmanship, one must have some practical experience—and the more the better. Among points to be noted are the following:—

The proper bedding of all faces is important, because lessening risk of initial strains; cover-plates, angles, tees, &c., in flanges, in stiffeners, and attachments of members must be close fits if a structure is to be stable. Planed edges, the closeness or otherwise of joint edges, are to be observed. Whether girder-plates have been properly levelled, or angles, tees, &c., straightened, or regularly curved as the case may be, can be observed in finished work; departure from accuracy in these respects being detected by the crookedness, or the winding of the built-up structure. Welds and sharp bendings should be looked after closely. All angle- and tee-stiffeners of rectangular form, all angles and tees turned to quick bends, square, and acute, are welded at the bends, on the flat webs by the insertion of glut pieces, or of lapping joints. These corners, on which a good deal often depends, must be looked after for signs of imperfect welding, being tested by observation and by hammer-blows. A point on which stress is laid in high-class work is the neat finish of flush outer edges. It is not a matter affecting strength, but it is nevertheless insisted on by good engineers. The time spent in finishing such edges is considerable if they have to be done after the riveting-up of the work. The aim, therefore, always should be to get them as true as possible before riveting-up, and to effect the latter with such accuracy that the edges will not be pulled out of truth by the rivets. It is a question mainly of shop methods, and neat work becomes as easy of accomplishment then as the rough workmanship which discredits some structures. The hot iron and cold iron saws are among the most valuable machines in a bridge and girder yard. They will cut ends as accurately as they can be planed, and either square or to any bevel. They will cut bar, plate, flat, or any section within the range of their capacity generally much more quickly than the work could be done by planing, because the saw makes but one cut, no matter whether  $\frac{1}{2}$  in. or 1 in. has to be removed.

Edges and rivet-holes resemble each other in one particular—namely, that the inspector has in all contracts, except those of the cheaper and rougher classes, to see that edges are planed, and the holes drilled or reamed. Sawn edges are equivalent to planed edges, and reaming is often held to be equivalent to drilling. Practice, however, differs in regard to the latter, and here, too, it is often a question of shop methods. With due care a punched and reamed hole is just as good as a drilled one. But then that depends on how the punching is done, and on the extent of metal removed by the reamer. Rivet-heads must be noticed, whether they are sound or cracked. The latter must be cut out and replaced. Note must be taken that bolts are properly made, threads cut cleanly on tie-rods, nuts a good fit, eyes well made, and other kindred points which a practical man will understand. The inspection of wrought-iron and steel construction work like that of cast work should go on simultaneously with the work; the workmanship must be observed as the work proceeds, because many imperfections are not readily detected, some not detected at all in a completed structure. Flush holes, as against overlapping holes, and drifting can only be noted properly during the progress of the work. Also, that rivets fill their holes properly without drifting.

The difficulties of erecting large works are often far greater than those involved in their construction in the shops. In the shops and contractors' yards there is generally plenty of tackle available, cranes, travellers, staging, blocking, shear-poles, and skilled help. In erecting work it is very often the case that there is no precedent to guide one: conditions are peculiar, and perhaps unique. The weight of responsibility is correspondingly great; life and property are at stake, and frequently work has to be done against time.

J. H.

The Todmorden School Board are about to erect a new school at Cornholme, on the Worsthorne estate, at an estimated cost of £5,000. The architect is Mr. Jesse Horsfall, of Todmorden.

#### IMITATION VARNISHES.

BY imitation varnishes is meant compounds that are prepared without the aid of heating the resins to dissolve them. In the "good old times of yore" it was the custom to distil or roast all resins, so as to effect their solution in oil and turpentine for the production of varnish. Nowadays, however, many resins are dissolved by chemical means, precipitated from the solution, and the precipitate thus readily forming a solution in the usual menstrua used in varnish making. The chemical process of dissolving resin consists in boiling the resin with a caustic alkali, such as caustic soda lye, by which means the resin is dissolved and taken up in the fluid. To precipitate it again in the solid form, the alkali of the fluid is neutralised by the addition of an acid, whence the resin is precipitated, and can then be collected, washed, and dried. Such precipitate is very soluble in linseed and other oils, turpentine, &c., even in the cold. Inasmuch, however, as the compound formed by dissolving the precipitated resin in oil or spirit is not a perfect varnish, as it exhibits feeble drying powers, it is customary to precipitate the resin from the alkaline liquid by the addition of some salt of lead or manganese that possesses siccative qualities, such, for example, as chloride or sulphate of manganese, sugar of lead, &c. The addition of these bodies to the alkaline solution of resin precipitates the resin, and at the same time these salts combine with the precipitated resin, and thus convey the siccative quality to the varnish which is made from such resin. The quantity of the precipitating agent has to be regulated, as only a definite quantity can combine with the precipitated resin, and any excess would simply become mechanically mixed therewith, and prove an undesirable component of the varnish, inasmuch as their presence renders the varnish dull and turbid. The general process of preparing these "resinates" is thus: a resin soap is made (by precipitating the powdered resin with the caustic soda) &c., and the solution thus obtained is mixed with a hot saturated solution of one of the salts above named, the nature of the metallic salt determining the nature of the resinate produced—e.g., whether resinate of lead, manganese, &c. After mixing the metallic salt and alkaline solution of resin, stirring, and allowing the mixture to rest, the resinate will rise to the surface of the fluid in a curdy mass. This is skimmed off, washed in warm water to free it from all traces of alkali, and then dried in hot air.

The resinate contains from 12 to 20 per cent. of oxide of lead in a soluble form, and of oxide of manganese about 10 per cent. Sometimes both manganese and lead salts are used together in precipitating the resin, whereby a double resinate is obtained, 7 per cent. to 9 per cent. of lead oxide, and  $1\frac{1}{2}$  to 2 per cent. of manganese being used in making this. The washed and dried resinate is in the form of a powder, and all that is needed is to dissolve same in the oil of turpentine.

Another form of this resinate is obtained thus: The resin is liquefied by melting it by heat, and after keeping it melted for some time, adding 10 per cent. of litharge or 5 per cent. of precipitated oxide of manganese, and continue the heating until all, or nearly all, the metallic oxides have been dissolved. The above proportion of oxides should not be exceeded, as any excess would remain undissolved in the varnish, and spoil its appearance. The resinates thus prepared are then mixed with the fluid vehicles used in making varnish. Instead of adding metallic salts to the resin, they are sometimes added to the oil vehicle, whence there is formed a linoleate. This process consists in saponifying the oil by boiling it with caustic soda lye, and then adding the soapy solution thus made to a solution of sugar of lead or chloride of manganese. When the linoleate is precipitated, it is collected, washed with water, and dried. Sometimes the linoleate is heated until it melts. Lead linoleate may contain 20 to 22 per cent. of lead oxide, and manganese linoleate 9 to 11 per cent. of manganese. The method of using these linoleates and resinates is to heat raw linseed oil to 300° F., and then add 5 lb. of the resinate or linoleate drier per gallon of oil, and stir the mixture until dissolved; this liquid drier is then added to the bulk of the oil, which should be heated 230° to 250° F., and if required the oil can be further oxidised or boiled. The oil varnish thus made is very useful and cheap.

A quickly-made copal varnish is one prepared

by dissolving the copal resin in a compound solvent. As is well known, some varieties of copal resin are very difficult to dissolve, and the usual process is to melt them or soften them by dry distillation before compounding the oil and resin; but by means of a compound fluid, consisting of equal measures of bisulphide of carbon, oil of turpentine, and benzole, the copal resin may be readily effected. The proportion of the solvent fluid to use is two parts by weight to one part by weight of the resin. The mixture is made in a closed vessel and allowed to stand several days. The solution thus obtained is decanted in this mixture with a fat oil.

Soap varnishes are also useful for common purposes. They are prepared by dissolving a good tallow soap in boiling water until a clear solution is obtained. This is filtered several times through felt filtering bags or cloth while it is still hot. The solution is again heated and diluted with an equal bulk of water, then a boiling-hot solution of alum is added to it so long as a precipitate (a sebate of aluminum) is formed. The precipitate is allowed to settle, the supernatant liquid poured off, and the precipitate washed several times with boiling-hot water. Then it is dried and heated in a vessel standing in boiling water until it becomes transparent. In a separate vessel oil of turpentine is heated to nearly the boiling-point, and then sufficient of the aluminum soap is added to form a solution of the consistency of thick varnish. If this becomes too thick when cold, it may be thinned with hot oil of turpentine.

H. C. S.

#### THE ELECTRICITY SUPPLY OF LONDON.

AT the ordinary meeting on Tuesday, April 5, of the Institution of Civil Engineers, the paper was read on the "Electricity Supply of London," by Mr. Arthur H. Preece, A.M.I.C.E. The supply of electricity on a commercial scale had been started in London after the passing of the Act of Parliament in 1888, which amended the Act of 1882, principally by extending the date for compulsory sale to the local authority from 21 years to 42 years. In 1888 many companies applied for Provisional Orders, and, in determining which were to be granted powers, and the districts over which the powers were to extend, the Board of Trade decided that competition would be advantageous to the public, and that it was advisable to allow one direct-current system to compete with one alternating-current system. There were now in London eleven important companies and five vestries supplying electricity, and three other companies and three vestries were taking steps to start works. The capital invested in the industry amounted to £6,000,000, and plant was installed to the extent of 80,000 H.P., the equivalent of 2,000,000 8c.p. lamps being connected to the mains. The total annual revenue was £800,000, and the total annual expenditure £450,000. Of the systems for supplying electricity in London, the alternating current was applicable to large areas where consumers were scattered, and it enabled the generating works to be established by the riverside, or where land was cheap and coal was easily unloaded. The undertakings using this system were the City of London Company, the Metropolitan Company, the London Electric Corporation, the County of London Company, the House to House Company, the Hampstead Vestry, the Islington Vestry, and the Hammersmith Vestry. The direct-current systems were divisible into two classes, the high pressure and the low pressure. In the former rotary transformers were used to reduce the high pressure, while the latter produced and distributed electricity at the same pressure at which it was supplied to consumers. The direct-current systems were applicable to compact areas, and, with the use of high pressure, to scattered or isolated compact areas. The chief advantages of the direct-current system were the possibility of using storage batteries, which could not be employed with the alternating-current systems, greater efficiency in distribution, and greater adaptability to motive power. The undertakings using the system were the Chelsea Company (high pressure), Charing Cross and Strand Corporation (high pressure), the Westminster Corporation, the St. James's and Pall Mall Company, the Kensington and Knightsbridge Company, the Notting Hill Company, the St. Pancras Vestry, and the Metropolitan Company (at one works). The generating works of the several undertakings in London contained many interesting features. No less

than twenty different works had been erected. The boilers used comprised the water-tube, marine, Lancashire, and miscellaneous types; but the preference for the water-tube boiler was very marked. The works were liable to sudden demands through fogs, and the quick-steaming properties of this type of boiler were of great advantage. The boilers were fired chiefly by hand with Welsh coal; but in the works of the City of London Company and the County of London Company mechanical stokers and cheaper coal were used. The use of extensive systems of steam-pipes was now being dispensed with. The multiplicity of valves was unnecessary, and the number of valves was being reduced, and arrangements were made as simple and with as few joints as possible. The present tendency was towards engines of the marine type for large outputs. The high-speed engine was not used for larger powers than 750 H.P. Some engineers, however, found engines of 350 H.P. sufficiently large, and the most convenient unit to adopt. The dynamos were similar in most works, and were always connected direct to the engines. Storage by secondary batteries was not extensively employed in London, as their maintenance had hitherto proved expensive. But a few works used them entirely for maintaining the supply after midnight, and in the daytime in summer. The author gave the results of a test of a small marine engine and alternator, showing the combined efficiency to be 85.5 per cent. The question of vibration had been of great importance in many works; no cure had been found effective when once vibrations were set up. High-speed engines must have three cranks to be free from appreciable vibration. The favourite methods of distributing electricity were to transmit current at a high pressure in heavily-insulated cables in iron pipes, and current at a low pressure in insulated cable in stoneware conduits or in cables heavily armoured and laid direct in the ground. Rubber was now little used, paper and jute, impregnated with insulating compounds, having been extensively adopted. The usual system of measurement of the electricity supplied was by meter, and the average charge was 5<sup>3</sup>/<sub>4</sub>d. per unit. The average charge in 1890 was 7<sup>3</sup>/<sub>4</sub>d., so that the price of electricity had been reduced in eight years no less than 25 per cent., equivalent to a reduction in the price of gas from 4s. to 3s. A curve was given to show the variations in the price of gas since 1870. The average price had varied between 4s. and 2s.; it was now 2s. 7<sup>1</sup>/<sub>2</sub>d. The cost of generating and distributing electricity had been greatly reduced in the last few years. In 1892 it was seldom supplied for less than 4<sup>3</sup>/<sub>4</sub>d. per unit. The usual cost was now 2<sup>3</sup>/<sub>4</sub>d. to 3<sup>1</sup>/<sub>4</sub>d. The actual cost of generating was about 1<sup>1</sup>/<sub>4</sub>d. per unit, and the cost of management, &c., about 1d. The direct current was everywhere produced at a cheaper rate than the alternating current. The difference was between <sup>1</sup>/<sub>2</sub>d. and 1d. per unit, or 20 per cent. cheaper. Since 1888 an important inquiry had been held by the Board of Trade regarding the maximum pressure permissible in customers' premises. The result of this inquiry, in 1896, was to increase the pressure from 150 volts to 250 volts. A comparison was made between the two largest companies in London—namely, the City of London Company, which supplied alternating current, and the Westminster Corporation, which supplied direct current. Both companies had nearly the same number of lamps connected to their systems, the number of 8c.p. lamps connected being 270,898 and 269,939 respectively. The capital expended was respectively £945,829 and £546,434; the annual incomes per 8c.p. lamp, 11s. 9d. and 7s. 9d.; the annual expenditures per 8c.p. lamp, 4s. and 3s.; and the costs per unit, 7<sup>6</sup>/<sub>4</sub>d. and 5<sup>8</sup>/<sub>4</sub>d. The industry was growing so rapidly that most undertakings had to seek new sites for generating works, and the tendency was to erect large works on the outskirts of London, where coal could be conveniently brought to the site, and where water could be obtained for condensing. The powers granted under Provisional Orders were limited as regards the compulsory purchase of land, and further powers were being sought by some companies from Parliament, so that they might be placed on the same footing as railway companies. No less than 40,000 H.P. was now being installed in London in order to meet the demand for electricity in the immediate future.

The new buildings for the University Extension College at Reading will be opened by the Prince of Wales on Saturday, June 11.

## ELECTRIC LIGHTING NOTES FOR ARCHITECTS.—XXI.

By AN ASSOC. INST. ELECT. ENGS.

### CIRCUIT TESTING.

AS the wiring of buildings is generally given out to contractors, it is of the utmost importance that the architect in charge should be able to test the complete installation before passing the same. It will, therefore, be necessary to refer to some simple everyday tests, which should be made both during the wiring and after the wiring is finished, and since so much depends upon the quality of the work, there is room for improvement in the matter of testing electric circuits, and it is hoped that cheap and inferior work may become a thing of the past as architects gain experience in electrical testing. The following are important tests with which architects should be conversant:—(1) *Continuity Tests*; (2) *Insulation Resistance Tests*; (3) *Leakage Current Tests*; and (4) *Tests for the Localisation of Faults*.

*Continuity Tests* are made during the wiring of buildings by the foreman in charge, and consist in forming simple closed circuits in which are connected in series a sensitive detector galvanometer, a battery (consisting of a number of cells in a portable case), and the parts of the circuit containing the joints to be tested. The deflections obtained by the galvanometer give some indication of the quality of the joints, and the continuity of the current is tested. This test, of course, gives no idea of faulty insulation, or the existence of earth connections, and it is, therefore, advisable to also make tests for *earths* and *short circuits*. For these tests the further ends of each branch are left perfectly free, the near ends being in turn connected in series with the detector and battery to earth. Should any earthing exist the galvanometer needle will be deflected. For short circuits the near ends of the lead and return wires should be connected by means of the galvanometer and battery (the further ends still being free). If a deflection is obtained, then it is clear that a short circuit exists, or that there is a partial connection between the two wires.

*Insulation Resistance* is the obstruction presented to the passage of electricity to the earth by the insulation covering of the conductor, and since it is essential to confine electricity along the definite paths formed by the conductors, so as to avoid loss and danger from leakage currents, insulation resistance should be very high. It is, therefore, usually expressed in megohms (million ohms), and since it is proportional to the thickness of the insulation and inversely as the length, the insulation resistance of a mile of the cable is taken as the standard of reference, and insulation resistance is therefore expressed in megohms per mile. Thus, if a cable has an insulation resistance of 300 megohm-miles, the insulation resistance of a half-mile of that cable would be 600 megohms, and that for two miles would be 150 megohms.

The following notes on insulation given in the Institution of Electrical Engineers' Wiring Rules will be found useful. Insulated conductors may be broadly classed under two heads:—(A) Those insulated with a material, as a dielectric, which is itself so impervious to moisture that it only needs further protection from mechanical injury or from vermin. (B) Those insulated with a material, as a dielectric, which, in order to preserve its insulation qualities, must be kept perfectly dry, and, therefore, needs to be incased in a waterproof tube or envelope, generally of soft material, such as lead, which is drawn closely over the dielectric.

When class A is used, the dielectric must be perfectly damp-proof, and not in any case less in thickness, measured radially, than 30 mils plus one-tenth of the diameter of the conductor; it should not soften at a lower temperature than 170° Fahr. The minimum insulation of a test piece cut from it should be:—

- 1,200 megohms per mile for conductors between 18 and 16 S.W.G.
- 800 megohms per mile for conductors between 16 and 14 S.W.G.
- 600 megohms per mile for conductors between 3/18 and 19/18 S.W.G.
- 400 megohms per mile for conductors between 7/14 and 39/16 S.W.G.
- 300 megohms per mile for conductors between 19/12 and 19/11 S.W.G.

the test being made at 60° Fahr., after one

minute's electrification, and after the test piece has been immersed in water for 24 hours.

When class B is used, the same conditions as to minimum thickness and softening temperature of the dielectric should be enforced, as in class A; its covering should be such that a test piece cut from the conductor and immersed in water will not break down with an alternating pressure of 2,500 volts, having a frequency of from 40 to 100 periods per second, applied for ten minutes between the conductor and the water, the test piece previous to immersion being bent six times (three times in one direction and three times in the opposite direction) round a smooth cylindrical surface not more than twelve times the diameter of the conductor measured outside the dielectric.

The coil from which the test-piece was cut should be tested in a similar manner to class A; but the minimum insulation resistance should be 300 megohms per mile for all sizes of conductors. Conductors of class A must be protected from mechanical injury, by being covered with stout braid or taping, prepared so as to resist moisture, and must be further protected by casing, or by being drawn into pipes or conduits. In the case of conductors insulated as in class B, great care must be taken to protect exposed ends of conductors where they enter the terminals of switches, fuses, and other appliances, from the possible access of moisture which creeps along the insulating material within the waterproof covering.

To make these insulation tests, a long and known length of the cable is taken and formed into a coil, which is then placed in a tank containing water at 65° Fahr. for at least 24 hours, with the ends free. The outer covering of the free ends should be removed for 8in. or 9in., and the core should be thoroughly cleaned with wood naphtha and dried in the flame of a spirit-lamp. Connection should then be made with the testing-set and generator (previously described), and the insulation resistance taken exactly after one minute's electrification, as mentioned above. It is also advisable to apply the electrical pressure for a considerable time, in order to stress the dielectric to such an extent as to break down weak parts of the insulation, and to detect any latent flaw which may exist. In this way the quality of the insulation may be determined. Not only should the insulating covering be of good quality, but every joint should be well insulated. When we remember that every joint and connection presents an opportunity for leakage, it is evident that the production of a high insulation resistance of a circuit depends as much upon the number of joints, switches, fuse-blocks, and other fittings as upon the dielectric, since these sources of leakage are all in-parallel with one another. The effect upon the insulation resistance of a circuit of introducing fittings and making connections in a system of conductors will be seen by considering the following example:—A circuit consists of 1,000 yards of cable, having an insulation resistance of 2,000 megohms per mile, and there are 200 fittings, having an insulation resistance of 750 megohms each; in addition to which there are ten joints in the circuit, each of 12,000 megohms resistance. Determine the insulation resistance of the circuit.

$$\begin{aligned} \text{Insulation resistance of cable} &= \frac{1,760}{1,000} \times 2,000 \\ &= 3,520 \text{ megohms.} \\ \text{Insulation resistance of fittings} &= \frac{1}{200} \times 750 \\ &= 3.75 \text{ megohms.} \\ \text{Insulation resistance of joints} &= \frac{1}{10} \times 12,000 \\ &= 1,200 \text{ megohms.} \end{aligned}$$

And these are in parallel with each other, so that

$$\begin{aligned} \frac{1}{R} &= \frac{1}{r_c} + \frac{1}{r_f} + \frac{1}{r_j} \\ \therefore R &= \frac{1}{\frac{1}{r_c} + \frac{1}{r_f} + \frac{1}{r_j}} \\ &= \frac{1}{\frac{1}{3,520} + \frac{1}{3.75} + \frac{1}{1,200}} \\ &= \frac{1}{.000284 + .266 + .00083} = 3.6 \text{ megohms.} \end{aligned}$$

It is, therefore, obvious that the installation comprising the conductors, fittings, and appliances should be thoroughly tested before current is switched on. The ohmmeter and generator (see Article XX.) enable the insulation resistance of a complete installation to be determined very



readily, and as we have already explained how to use this testing set—in the last article—it will only be necessary to add the following note:—“The whole of the lamps or appliances for utilising the energy having been connected to the conductors, and all fuses being in place, an E.M.F. equal to twice the E.M.F. which will be ordinarily used is to be applied (many generators give 200 volts), and the insulation resistance between the whole system and earth must be measured after one minute’s electrification. The insulation should then not be less than 10 megohms, divided by the maximum number of

earth connection is introduced to show that the arrangement is a typical Wheatstone’s Bridge.

A moment’s consideration will suffice to prove that if the resistances P and Q are adjusted so as to produce equilibrium, the following relation holds:—

$$P \times fE = Q \times Af, \text{ or } \frac{P}{Q} = \frac{Af}{fE}$$

where Af and fE denote the resistances of Af and fE respectively. And by adding one to each side of the equation we obtain—

$$\frac{Af}{fE} + 1 = \frac{P}{Q} + 1$$

or— 
$$\frac{Af + fE}{fE} = \frac{P + Q}{Q}$$

Now, let x = length of Ef or distance of the fault from E, and l = the total length of the loop EfA. Then—

$$\frac{Af + fE}{fE} = \frac{l}{x} = \frac{P + Q}{Q}$$

and— 
$$x = \frac{Q}{P + Q} \times l$$

$$= \frac{Q}{P + Q} \times \text{total length of the loop } AfE.$$

From these results it is obvious that both the post-office bridge and the metre bridge may be conveniently used for making the test, and the connections for the former are given in Fig. 72, in which the same letters are used as in the previous figure, and it will be observed that the battery and galvanometer have been replaced each other as compared with their positions in the ordinary resistance test (given in Fig. 68). The method of making the test is as follows:—Unplug 1,000 ohms from the ratio arms Q, and close the battery key K<sub>1</sub>. By closing the galvanometer key K<sub>2</sub> for an instant, a deflection is obtained

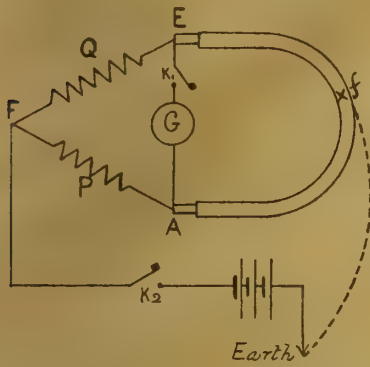

Fig. 71.

amperes required for the lamps and other appliances. The installation may then be set to work, and a second and similar test should be made after an interval of fifteen days. In each test, if the insulation of the whole is below standard, the work should be divided up by the departmental switches and tested separately, in order to locate the faulty section. The value of systematically testing and inspecting apparatus and circuits cannot be too strongly urged as a precaution against fire. Records should be kept of all tests, so that any gradual deterioration of the system may be detected. Cleanliness of all parts of the apparatus and fittings is essential. No repairs or alterations should be made when the current is on.”

It may also be mentioned here that if the current is to be taken from a supply company’s mains, the inspector of the company will make a separate test before connection is made with the mains.

**Localisation of Faults.**—Should a fault exist in a cable, it should be removed at once. Of the several methods of localising the fault in a cable the simplest and most convenient is that known as Murray’s Loop Test, especially when both ends of the faulty cable are accessible, or when the far ends of the lead and return may be conveniently united. In this method a loop is formed with the main containing the fault, as the cable must form part of the complete circuit from and to the testing station. To do this, the positive and negative mains must be connected together at any convenient point beyond the fault, so that

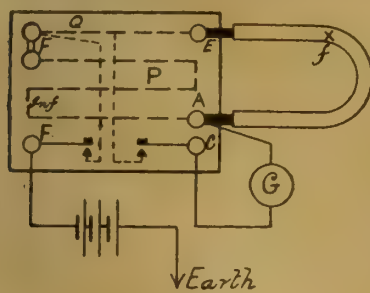

Fig. 72.

the lead and return form a single circuit. In Fig. 71 let EfA represent such a loop in which there is a fault at f, so that Ef and fA are the segments into which the fault divides the loop, and it is evident that by connecting the loop with two resistance coils, Q and P, and a sensitive galvanometer, G, as shown (a battery being connected to the common junction of the two resistance coils and to earth), we have an arrangement of conductors corresponding to the Wheatstone’s Bridge arrangement, described in Article XX. The dotted line connecting the fault f with the

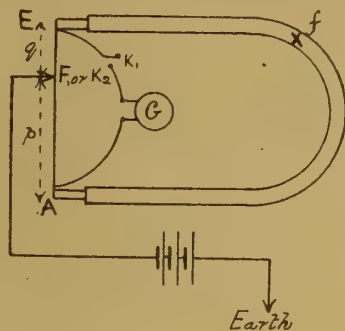

Fig. 73.

which indicates the direction of the deflection when more resistance must be added, when making the test, in the rheostat arm P. Having determined this, the resistance of P is adjusted until no current passes through the galvanometer when the two keys K<sub>1</sub> and K<sub>2</sub> are both depressed. If the deflection, however, indicates too little when all the resistances in the rheostat arm P are unplugged, one of two possible causes may account for the inability of getting no zero deflection—(1) the connections may be wrong, and (2) the position of the fault f may be too near E, for the ratio of Q to P used—i.e., when Q = 1,000 ohms and P = 11,110 ohms.

If the connections are correct, then a deflection indicating too much will be obtained on removing the infinity plug in the arm P, the keys K<sub>1</sub> and K<sub>2</sub> both being depressed, Q still being 1,000 ohms. Having decided this point, try 100 ohms for Q instead of 1,000 ohms, and again adjust the resistance of P until zero deflection is obtained. If Q = 100 ohms be too great, try Q = 10 ohms, and if the test then fails it is certain that the fault f is very near to E. In such a case the ends of the loop of the cable should be reversed—i.e., are connected to the box in the opposite way, and Q = 1,000 or 1,110 ohms is tried, and the position of the fault determined. If x is the distance of the fault from E, then in all cases—

$$x = \frac{Q}{P + Q} \times l$$

To understand the connections when the Metre Bridge pattern of the Wheatstone’s Bridge is used for making the test, it is only necessary to imagine that the two resistance coils P and Q of Fig. 71, form the stretched wire of the bridge, and that the end of the battery wire at F is the slider K<sub>1</sub>, and we obtain the arrangement shown in

Fig. 73, E being the zero end of the scale. By adjusting the position of the slider K<sub>1</sub>, a position may be found so that the ratio of the segments into which the metre-wire is divided is the same as the ratio of the segments Ef and fA of the cable loop; then, if q and p are the lengths of the wire as shown in the figure—

$$x = \frac{q}{q + p} \times l = \frac{q}{100}$$

as before, when no deflection of the galvanometer needle is obtained on depressing both keys K<sub>1</sub> and K<sub>2</sub>.

As may be supposed, the leads connecting the

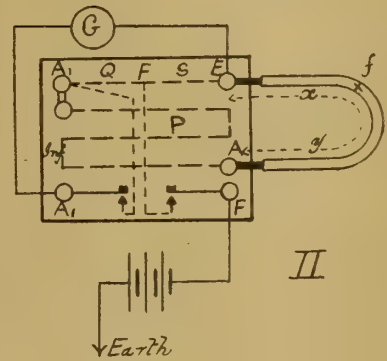
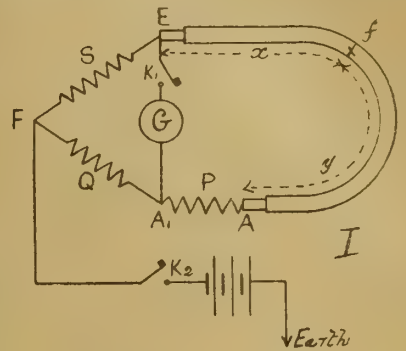

Fig. 74.

ends of the faulty cable (forming the loop) to the terminals E and A are often of a different cross-sectional area to that of the cable, and in making the calculation for determining the position of the fault, the equivalent length of the leads must be taken into account as being part of l, the total length of the loop. In all cases the leads should be as short as possible. By equivalent length is meant a length of the cable having the same resistance as the leads. It may also be mentioned that the size of the battery—i.e., number of cells in series—depends upon the nature of the fault, a large battery being required if the fault is of high resistance. In some cases several Leclanché cells are sufficient.

As an alternative test for determining the position of a fault, we may mention Varley’s Loop Test, which is a simple modification of the preceding method. It, however, can only be used in conjunction with the Post-Office box, and the difference between the two tests consists in introducing an adjustable resistance at one end of the loop. The connections are shown in Figs. 74 I. and II., the added resistance being connected between A and A’. The ratio of the resistances Q and S of the ratio arms is maintained constant, useful values in practice being Q = 1,000 and S = 10 ohms; and P is adjusted until equilibrium is attained. It, however, is important that the battery key K<sub>2</sub> should be depressed before the galvanometer key K<sub>1</sub> in closing the circuit. On breaking the circuit K<sub>1</sub> is opened before K<sub>2</sub>. The fault is at f, as before, and if the resistance R of the cable EfA be not accurately known, it must be determined by the ordinary method.

When equilibrium is attained, we have the following relations:—

$$S : Q :: x : (y + P)$$

$$x = R - y.$$

And since— 
$$S(y + P) = Qx$$

$$= Q(R - y)$$

$$\therefore y(S + Q) = QR - SP$$

and— 
$$y = \frac{QR - SP}{S + Q}$$

If Q were taken equal to S, this result would reduce to—

$$y = \frac{R - P}{2}$$

but the result is not so accurate as when Q is large compared with S. It will, of course, be observed that y is the resistance of the segment connected to A. Let l again denote the length of the loop E f A, and Y the distance of the fault from A, then evidently—

$$\frac{y}{R} = \frac{Y}{l} \quad \text{and} \quad Y = \frac{l}{R} \times y,$$

therefore, the distance of the fault from A is given by the equation—

$$Y = \frac{l(QR - SP)}{R(S + Q)}$$

(To be continued.)

SANITARY WORK.—V.

CLEARING DRAINS.

ONE of the commonest experiences of those who are in any way concerned with the maintenance of drains from a number of houses or other occupied buildings is the unwelcome intimation that a drain, gully, sink, or other sanitary fitting is choked, and must, therefore, receive immediate attention.

Before discussing the actual details connected with the operation of clearing drains and their connections, it is desirable to notice the varied causes which may lead to these appurtenances becoming ultimately blocked. In all cases where—from ignorance or motives of false economy—the drains are improperly constructed in the first instance, stoppages must be expected as a natural consequence, even though the sanitary fittings be subjected only to proper and legitimate treatment.

By far the greater number of obstructions are, however, the direct result of improper or careless usage. This is more particularly observed in connection with the drainage arrangements for houses of the poorer class, large factories, workshops, schools, public institutions, &c. Judging from results, it would appear that very many persons are strongly imbued with the idea that drains and their accessories are designed to receive and remove rubbish of every conceivable description. Provided the article can in any way be forced into the drain sufficiently far to be out of sight, it is apparently presumed that the drain will afterwards digest or otherwise remove the substance without any further attention.

Sometimes the stoppages are entirely caused by evilly-disposed persons passing articles into the drains, so as to dispose of them without indicating the source from which they originated. To deposit articles of this description in the domestic ash-bin in the usual way might possibly lead to inquiries, if not to ultimate detection, and for this reason the drains are frequently selected as a convenient transporting medium.

Considering the almost endless variety of foreign substances which are wilfully or thoughtlessly passed into the closets, sinks, and other sanitary appliances, the wonder is not so much that the drains eventually become choked, but that under such unfair and constantly recurring conditions they fulfil their purpose so efficiently as they are usually found to do in actual practice.

Amongst the numerous articles which are found in clearing operations, and which must have been intentionally passed into the drains, may be mentioned old tins, bottles, worn-out boots and shoes, disused wearing apparel, &c. On the other hand, the entry of large pieces of soap, scrubbing brushes, pumice-stone, bath bricks, table knives, spoons, &c., generally result from carelessness. Under ordinary circumstances, the passage of the latter class of articles into the drains is prevented by the gratings or guards fixed to the sinks and gullies.

Where the drainage arrangements are properly constructed and maintained in efficient working order by a periodical examination, testing, and subsequent remedying of all defects due to ordinary wear and tear, it may be safely assumed that with fair usage such an incident as a stoppage will be a very rare occurrence. As a general rule, it may therefore be assumed that stoppages result almost entirely from preventable causes, such as defective construction, unfair usage, or carelessness.

When the obstruction has been removed and the drain restored to its normal condition, a

careful examination should at the same time be made, in order to definitely determine the contributory cause of the stoppage. Should this be traced to any defective material or workmanship in the drain or fittings, it is desirable that the necessary alterations be made before finally leaving the work. If the stoppage has occurred

Fig. 37.

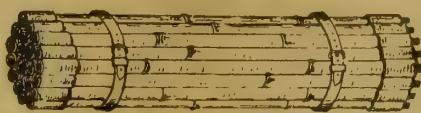

Fig. 38.



Fig. 40.

by reason of careless or improper usage, then the occupants should be cautioned against the repetition of such misuse, so that a recurrence of the stoppage may as far as possible be prevented.

In all drain-clearing operations the principal object to be attained is the speedy removal of the obstruction without disturbing or interfering with the general construction of the drains or sanitary appliances. Only as a last resource should the drains be broken into, as it is not only expensive but difficult to make good the disturbed work in such a way that the internal portion of the joints of the new pipes shall be clean and axially true, and the whole of the repair left sound and watertight.

Figs. 37 to 45 are sketches showing a set of drain-clearing rods together with the various accessories used in connection therewith. The drain-rods consist of stout brown malacca canes, mounted with brass male and female screw connections, so that the whole may be readily put together for use. The brass mountings must be securely riveted through the canes, the screw-threads being accurately finished so that the rods may be interchangeable throughout. A set of drain-rods when screwed together is usually about 100ft. in length. It is not desirable to use drain-rods exceeding a length of 100ft. to 120ft., as longer lengths are apt to become unmanageable, more especially when working in confined positions. For convenience of transport the rods are secured in a bundle by two leather straps, as shown in the illustration (Fig. 37). Iron drain-rods put together with a simple form of joint are also sometimes used.

Fig. 38 is the sketch of a "spring-hook" used for dislodging and breaking up accumulations of solid matter in the drains. The "double worm-screw" shown in Fig. 39 is more particularly designed for removing rags, paper, and other similar impedimenta.

Figs. 40 and 41 are illustrations of the ordinary "clearing wheel" and "universal roller." The latter instrument is arranged with a swivel joint,

Fig. 39.



Fig. 41.



Fig. 42.



Fig. 43.

so as to allow the rollers to glide easily over the joints or round the bends of the drain-pipes. Sketches of a "plain" and "jointed scraper" respectively are indicated in Figs. 42 and 43. Their general outline sufficiently explains their use. What is known as a "drain-brush" is shown in Fig. 44. They are usually made of bass fibre or whalebone. Drain-brushes form a useful adjunct for sweeping and cleansing pur-

poses, and may be obtained from 4in. to 24in. in diameter.

Fig. 45 is an illustration of a "solid plunger." The disc is made of stout leather or indiarubber, and of sizes generally varying from 4in. to 8in. in diameter. Should it be necessary to pass the drain-clearing apparatus beyond a very sharp curve or bend, the drain-rods already described are insufficiently pliant to effect this object. Under such circumstances, a special description of



Fig. 44.

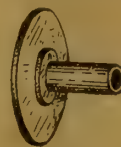

Fig. 45.

rod, known as "flexible-cane rods," may be utilised with advantage. These rods are made up of a number of thin canes twisted together (see Fig. 46), in order to provide the requisite flexibility together with sufficient stiffness for the purpose.

A well-designed drainage system must be so arranged that every portion is accessible, either directly or by means of drain-rods. For this purpose, inspection chambers should be constructed at the junction of two or more drains, and also at any bend or change of direction. The inspection chambers or manholes should preferably be placed not more than 200ft. apart.

Where such precautions are adopted it becomes a very simple matter to inspect and cleanse the drains at all times, and thus remove any obstruction that may take place without disturbing or interfering with the pipes and fittings.

In the case of old drains which have been laid without providing the necessary means of access to the different portions of the system, it is often-times a matter of the greatest difficulty to remove



Fig. 46.

a stoppage, except by opening the ground, and breaking into the drain at one or more points.

Should it not be practicable to use drain-rods, the obstruction may sometimes be reached and dislodged without otherwise disturbing the existing work by inserting a long thin iron rod at an adjacent gully or other convenient opening. Another method which is frequently adopted is to try and break up or force the obstruction through the drain by means of an indiarubber or leather plunger (Fig. 47) worked vigorously at the opening nearest the stoppage. In many instances, however, instead of removing the obstruction, the result is to compress it more tightly into its position, so that it finally becomes necessary to remove the substance by digging down to and opening the drain.

When circumstances necessitate the breaking



Fig. 47.

into a drain for clearing purposes, it is advisable to arrange for the construction of a manhole at this point (if means of access is otherwise deficient) instead of merely making good the drain in the ordinary manner. More especially should this precaution be taken when—as is frequently the case—the obstruction occurs at a junction or bend in the drains.

Whilst stoppages in drains and fittings may

not be absolutely and entirely avoidable, particularly where they are subject to rough usage, as in public institutions, &c., yet much can be done towards practically attaining this end by a method of periodical inspection and cleansing.

It is interesting to note that the London School Board have recently introduced a system whereby each school is visited in rotation, and the entire sanitary arrangements of the building thoroughly overhauled and cleansed by a staff of men specially appointed for the purpose. Any defects which may be observed are also taken in hand and remedied at the same time. In many instances the nucleus of what would have quickly resulted in a serious stoppage has been easily removed at a minimum of expense compared with the probable cost and serious inconvenience involved in clearing a drain which has become completely choked.

Similar schemes for the systematic inspection and cleansing of the draining systems appertaining to other important groups of buildings might be advantageously adopted by various public bodies. Such a practice would undoubtedly materially assist in maintaining a proper degree of permanent sanitary efficiency.

#### SYSTEMS OF STEAM-HEATING BUILDINGS.

SO many systems of heating divide the attention of the architect that he often disposes altogether of the matter, and places the heating of his buildings into the hands of competent engineers, who do not always adopt the most desirable system, but that which they have an interest in—it may be some special patented system, excellent in certain situations and for certain kinds of building, but not the best adapted for the particular purpose. Mr. J. J. Blackmore, in the *Engineering Magazine*, describes three kinds of steam-heating which have been developed—the “gravity system,” in which the steam generated in the boiler rises to the radiators, and being condensed, the water is returned to the boiler by gravitation through a return pipe. The second system is called the “mechanical,” because mechanical means are employed to reduce “the pressure of steam on the system from that carried in the boiler, and mechanical appliances are used to return the water of condensation from the return pipes back to boiler. These may be in the shape of an automatic steam trap or a pump and governor.” The third is the “exhaust steam system,” in which “the heating is done by steam that has been used to drive engines or pumps. Mechanical appliances are also used for controlling and directing the steam through the system.” Of these systems the first is that which obtains most favour. It has the advantage of being a low-pressure system, is quite safe, and if properly constructed will work well on ordinary buildings without indicating any pressure on the steam-gauge, the atmospheric pressure being able to distribute the steam to the radiators. Mr. Blackmore prefers the vertical type of cast-iron boiler to the horizontal. In the former separate sections are bolted together, each resting on the foundation; in the latter the sections are set one on another. Therefore, it is easier to enlarge the “vertical” type by adding sections, and the grate area is enlarged at the same time. The joints are exposed to view, and the boiler can be put together without the aid of packed joints, and the vertical form promotes a quicker circulation. The horizontal boiler cannot be so easily enlarged or cleaned; the joints are packed, and they need more frequent repair. Steel and wrought-iron tubular boilers are also used; and the large steam space makes the apparatus work more uniformly and economically than the cast-iron sectional boilers, especially for larger boilers.

The single-pipe system of distribution is admirable for ordinary heating by radiators; the water of condensation is carried in the direction in which the steam flows, and is returned to boiler with little loss of heat. One plan of distribution by this method shows the horizontal pipes dropping towards the bottom of the rising pipes, and relief pipes carry the water back to boiler. Another and better plan is to run a main feed-pipe to top of building, and the branch pipes are carried to the radiators. Pipes are dropped to feed the radiators in the floors below, and in the cellar return-pipes return the water to the boiler. If properly executed, this last method has advantages: the steam is carried through the whole system in the direction of the water-flow.

Mr. Blackmore formulates a simple rule for the proper size of steam-pipe, the rules given in textbooks varying considerably, the results, according to four writers, varying as much as 130 per cent. Many useful hints and suggestions are made by the author of the article, into which we cannot enter. Of course, there are well-known rules which ought to be strictly observed: as that all the horizontal pipes should have a regular fall in the direction the steam flows—say 1 in. in 10 ft. The startling cracking noises heard are due to the condensed water remaining in the pipes. We still think that a flow-and-return pipe is necessary to each radiator; but the author says it is not necessary, as water will return down a rising pipe while steam is flowing up, clinging to the surface of the pipe. The question of radiators direct and indirect is discussed, and of these there are several good ones in the market. The indirect radiator placed in a chamber under the room has decided advantages; but this is a point into which we cannot enter here.

#### COMPARATIVE STRENGTH OF RIVETED AND BOLTED JOINTS.

SOME important tests have, says the *American Architect*, been made at the Watertown Arsenal during the past year to ascertain the comparative strength of riveted and bolted joints. The tests were carried out at the request of the Berlin Iron Bridge Company, which prepared the material for the trial. A great variety of tests were made with joints riveted in different ways, and with different dimensions of plates and bolts, some which represent those most commonly met with in building work. In most of the tests the joints were made with the rivets or bolts in short rows, as is usually the case in building, and they were sometimes steel and sometimes iron. The steel was naturally stronger in each case. Two plates,  $\frac{1}{2}$  in. thick, joined with two  $\frac{1}{2}$  in. rivets or bolts, held 48,510 lb. with riveted joint, and 37,690 lb. with bolts; with three rivets, in a single row, the joint parted at 79,960 lb., and with bolts, similarly disposed, at 58,120 lb. With four rivets, in a single row, the joint held 100,000 lb., and with four bolts, 76,900 lb. Two  $\frac{1}{2}$  in. plates, joined with  $\frac{1}{2}$  in. rivets or bolts, held with ten rivets, 169,700 lb.; with bolts, 105,200 lb.; with eight rivets, 138,800 lb.; with eight bolts, 87,100 lb.; with six rivets, 105,900 lb., and with six bolts 66,700 lb. With  $\frac{1}{2}$  in. plates, riveted in two rows, a joint with ten rivets held 157,400 lb., and with bolts only 84,000; with eight rivets, 127,100 lb.; with bolts, 81,800 lb.; with six rivets, 96,000 lb., and with bolts 51,800 lb. These tests were made with  $\frac{1}{2}$  in. bolts or rivets, so that an increase in the diameter of a bolt appears to have an important influence in bringing its efficiency nearer to that of a rivet. Three-quarter-inch plates, joined with two  $\frac{1}{2}$  in. rivets, held 89,800 lb.; with bolts, 59,900 lb.; with three rivets, 139,300 lb.; with bolts, 112,800 lb.; and with four rivets, 175,400 lb.; with bolt 140,100 lb. The same plates, joined with twelve  $\frac{1}{2}$  in. rivets, in a chain, gave way at 169,900 lb., and with bolts at 113,109 lb. These results seem to indicate clearly that the average strength of a bolted joint is only about two-thirds that of a riveted joint of the same sort, and that, if the diameter of the bolts or rivets is rather small in comparison with the thickness of the plates, the strength of the bolted joint may not be much more than one-half that of a riveted joint. It is therefore advisable, in designing bolted joints, to provide at least one-half more bolts than the number of rivets given by the ordinary rules for riveted joints. A lofty structure, attached to the ground only at its foot, and affording little opportunity for diagonal wind-bracing, is peculiarly liable to injury through lack of rigidity at the joints; and if bolts—which never hold the parts together as firmly as rivets—are to be used in the joints, an additional allowance should be made to their number, as a protection against the effect of momentum due to swaying.

#### DISCOVERIES OF BUDDHIST REMAINS IN INDIA.

MR. VINCENT SMITH, of the Bengal Civil Service, has published a statement as to the recent discoveries of Buddhist antiquities in India. The first of these is the home of Gautama Buddha, who lived about 500 B.C., and who is known to have been the son of the Raja of Kapilavastu, a small State in the Nepal Terai, bordering on the

modern Oudh. The site of Kapilavastu has long been sought for, and it is only within the past three years that the accidental discovery of an inscribed pillar erected by the Emperor Asoka, in the third century B.C., fixed with certainty the site of the city. The ruins, which were lately visited by Mr. Smith, are, so far as is yet known, all of brick; they are buried in jungle, and are so extensive that many years would be required for their exploration. The city was destroyed during the lifetime of Gautama, and when the first Chinese pilgrims visited the place in 410 A.D. it was a mass of desolate ruins, and there is no indication that it has since been occupied. The excavations now in progress are bringing to light buildings more ancient than any previously known in India. More interesting even than Kapilavastu is the discovery of the Lumbini Garden, the traditional birthplace of Gautama. The sacred spot has been found marked by another of Asoka's pillars, on which the inscription is perfect. This is also in Nepalese territory, five miles from the British frontier. The pillar stands on the western edge of a mound of ruins about 300 ft. in diameter, and on the south side of the mound is the tank in which the child's mother bathed after his birth. Another discovery, which was made in a brick tumulus, close to the British frontier, is that of relics of Buddha himself. These consist only of fragments of bone, which were deposited in a wooden vessel that stood on the bottom of a massive coffer more than 4 ft. long and 2 ft. deep, cut out of a solid block of fine sandstone. This coffer was buried under 18 ft. of masonry, composed of huge bricks, each 16 in. long. The wooden vessel was decayed, and with it was a bowl of rock crystal, the largest yet discovered in India, and also five small vases of soapstone. All these vessels were partially filled, in honour of the relics, with a marvellous collection of gold stars, pearls, topazes, beryls, and other jewels, and of various objects wrought in crystal, agate, and other substances. An inscription on the lid of one of the soapstone vases declares the relics to be those of Buddha himself, and the characters in which this inscription is written are substantially the same as those of the Asoka inscriptions, and indicate that the tumulus was constructed between 300 and 250 B.C. Buddha spent many years preaching and teaching at the city of Sravasti. The site of this famous city was long sought in vain. Mr. Smith now states that it is in the jungles of the Nepal Terai, about 11 miles from the station of Nepalganj-road on the Bengal and North-Western Railway. Its remains, like those of Kapilavastu, are buried in jungle; but they seem of great extent, and are found precisely where the Chinese pilgrims of the early centuries of the Christian era stated that Sravasti was. Kusanagara, where the aged Gautama died, has not yet been found; but Mr. Smith suggests that it is not very far from the massive ruins of Simranu, north of the Champaran district of Nepal, and thinks that a place called Dewdurpa, 13 miles north of Simranu and 54 miles south of Kathmandu, will turn out to be Kusanagara.

#### ST. MARY'S CATHEDRAL, EDINBURGH.

THE south choir aisle, which has been formed into a separate chapel, is divided by wrought-iron grilles from the choir, and has now been further inclosed by an elaborate wrought-iron grille and gates at the diagonal arch entering off the south transept, and at the eastmost bay by a curtain of crimson silk attached to a wrought-iron frieze which is a continuation of the wrought-iron work dividing the choir from the chapel. An altar of “jaune jaspé” marble with a reredos of “rouge jaspé” has been erected about 18 in. in front of the east end of the aisle. The altar and reredos, which are of Romanesque design, are raised on three steps of marble. Two of these steps rise from a platform of red marble mosaic, bordered by a marble step 6 in. above the stone floor. All the steps are of *campan mélangé*. The altar is panelled on front and sides, and has a moulded base and a moulded and enriched cornice. The centre panel contains an enriched cross. The moulded cornice of the reredos rises 1 ft. 9 in. above the altar table, and extends beyond it about 1 ft. on each side. The reredos is flanked by octagonal shafts having massive richly moulded bases and carved capitals, also by panelled pilasters projecting from its face. Over the centre of the reredos rises an enriched panel containing the letters I.H.S. On the

cornice of this rests a lofty massive bronze cross very elaborately chased in Romanesque detail, and on small marble blocks projecting above the cornice, over the pilasters, are massive bronze candlesticks, quaint in form, and enriched with elaborate ornament, similar to that on the cross. Both cross and candlesticks are fine examples of artistic work in metal. Two bronze flower-vases of unique form are placed between the cross and the candlesticks. The altar-rail is of polished walnut, supported on finely-modelled bronze standards. The altar and reredos are built solid, and, the marble being rich in colour, make a very effective grouping with the stained-glass windows beneath which they are placed. A double piscina of polished free-stone has been inserted in the south wall. The chapel is seated with chairs, and provided with substantial mats and suitable kneeling hassocks. The electric light has been introduced with groups of lamps above the capitals of the pillars. The work, which has been seven months in progress, has been carried out at the expense of a member of the congregation, from designs by Mr. George Henderson, of Messrs. Hay and Henderson, architects. The marble-work has been executed by Messrs. Field and Allan, the metal-work by Messrs. Singer and Sons, Frome; and the hangings are by Messrs. Whytock, Reid, and Company. We understand that the chapel will in future be used for the daily celebration of the Holy Communion, for matins on Saturdays, and for the various minor services.

### THE WORKING VALUE OF FUELS.

By THOS. FLETCHER, F.C.S.

IN some experiments carried on at the New York State Veterinary College, it was found that the heat lost by ventilation was 39° of the whole, and my attention has been called to the fact that these figures, which may be taken as correct, differ seriously from those given in my book on the "Commercial Uses of Coal-Gas," where the amount lost in Messrs. Walkers' bottling stores is given as varying from 22½° to 25°. The explanation is simple: the minimum ventilation required in living-rooms is 500c.ft. of air per hour for each adult. In bottling stores, only a fraction of this is required—in fact, no provision whatever is made for ventilation, and all which takes place occurs from leakages, and the constant opening of doors for the passage of trucks and barrels. The figures given by me are clearly stated as being observed results in practice in bottling stores only. I had no opportunity, before the book was published, of making exact experiments in living-rooms, these being very difficult, if not impossible, under ordinary conditions, in any house, the speed of the air currents in the flues varying almost from minute to minute. Recent experiments in rooms where the ventilation is controlled and can be measured have established a rule, which may be safely relied on for every practical purpose. The accepted standard is the British thermal unit—*i.e.*, the amount of heat necessary to raise the temperature of 1lb. of water 1° Fahrenheit, and one unit is required per hour for each degree rise of temperature over the outside for each square foot of glass or for every 4sq.ft. of exposed wall, and two-thirds more for the loss of heat by ventilation in ordinary living-rooms. The loss of heat in living-rooms is an unknown quantity, as it varies in every room, and in the same room from hour to hour; but, taking the theoretical value of coal-gas at 660 British thermal units per cubic foot, that of coal 13,000 units per pound, and of coke 10,000 units per pound, it becomes easy to calculate the effective value and the loss of heat in different systems. A fuelless gas-stove may be taken as the highest type of efficiency, and using this, 1c.ft. of gas per hour will be required for every 660sq.ft. of glass, or every 2,680sq.ft. of exposed wall, for every 1° rise of temperature over the outside, and in addition to this, two-thirds of a cubic foot for loss by ventilation. Taking a room 22ft. square and 10ft. high, with all walls exposed, 2c.ft. of gas per hour will maintain a rise of 3° over the outside, allowing for the average window surface. The exact figures for warm-air stoves with flues, and for open fires, are not available, and perhaps not possible; but for average practice it may be taken that nearly one-half the total heat is lost in a warm air stove with a flue, and two-thirds with an open fire. This can hardly

be considered as all loss, as the ventilation necessary for comfort and health cannot be always obtained without some assistance, and the so-called loss may be partly taken as useful work done. The whole subject is beset with variations and difficulties, and any standard can be proved to be seriously wrong in individual cases; but the figures given may be taken for average work. It must be clearly understood that the figures given are for maintaining the heat, not for raising the temperature of any room quickly, for which a much larger fuel consumption is required.

#### HEATING PLANT HOUSES.

These figures work out in practice in greenhouse heating, where steady temperatures are required night and day, and the loss from any system of boiler or stoves can be readily calculated, a matter of interest to nurserymen whose fuel consumption is a question of vital importance. The loss in most forms of boilers is enormous, and the subject needs careful consideration. For this purpose the calculation is exceedingly simple, on the basis of 10,000 units per pound of coke. One pound of coke burnt per hour will give a rise of 10° for every 1,000sq.ft. of glass, or 4,000sq.ft. of exposed wall, not allowing for loss by ventilation. For this, one-half more fuel must be allowed. This gives us the maximum possible duty, and a comparison with the fuel burnt gives the waste. Where the flue heat is not utilised, there is no doubt that at least 50 to 60 per cent. of the fuel is completely wasted in most of the systems at present in use, and the value of the fuel is not considered as it should be. In my own case, with a Chatsworth boiler, burning gas coke, and heating a range of houses 45ft. by 30ft., one-half which is kept at a tropical temperature, the flue-heat not being used, the calculated consumption is 8lb. per hour by theory, allowing one-eighth loss for wind, as the houses are on high ground and rather exposed (this wind allowance will vary in different districts). The actual winter average is 11½lb. per hour, showing a waste of 31½ p.c., nearly one-third of the fuel—this being with a first-class boiler, clean, well set, carefully fired, and of the correct size for its work. It is doubtful if better results could be obtained in practice under ordinary conditions.

The following rule may be taken as a guide for coke-fired greenhouse boilers:—

For every 1,000sq.ft. of glass, and for every 4,000sq.ft. of exposed wall, for each 10° rise of temperature over the outside—

Loss through glass and walls .....	16oz. per hour.
" by ventilation .....	8oz. " "
" by wind (average) .....	3oz. " "
" by boiler and flue .....	13oz. " "
Total .....	2½lb.

Three-fourths of the flue loss can be recovered by taking these under the beds in the houses. Any fuel consumption over this may be taken as waste which can be prevented.

#### REPLACING FRONTS.

IN the United States the removal of whole fronts of buildings is often effected. One of these is recorded. The least possible obstruction to the street or interference with the occupants of the interior was necessary. Mr. H. Sheeler, of Chicago, removed the front wall of the sixth story of a nine-story steel building, and built in a new front with projecting bay windows without disturbing the inmates. Some hundreds of tons above the sixth story had to be supported. It had to be lifted from its original supports and temporarily sustained high in the air for many days, and then seated on new work. No scaffolding or false work from the ground could be attempted, or to introduce shores. Messrs. Grace and Hyde, architects, designed the new ironwork, consisting of 250 tons of columns, beams, and other structural steel, besides the wall masonry, &c., forming the new front of a section of the wall about 80ft. long by 12ft. high across the centre front of the building. The twelve windows of the fifth story were separated by piers. The first step, as described, was "to cut down the wall under the window-sills to the fifth-floor level between all the piers, and then to lay a pair of 10in. I beams 8ft. long in the floor close to each side of each pier, and at right angles to front wall, so that they all projected 2ft. beyond face, and formed cantilevers with bearings on the surface of the wooden floor. Twenty-four pairs of beams were thus laid, and

upon them were set two continuous sills parallel to wall, one 18in. outside of it and the other 3ft. inside. Over each side of each cantilever a 6-ton jack screw, and 8in. by 8in. timber post were set on the sill, these tops being cut to bear on the underside of an 8in. I beam which supported the wall, and took bearing on the under side of the 6in. floor beams." When the jack-screws were turned up to a solid bearing, the weight of the wall and the wall end of floor beams from the sixth floor upwards were taken and transmitted through the posts and jack-screws to the cantilevers on the fifth floor. While the superstructure was thus supported the old front was removed and the new one put in. The continuous stringers or sills distributed the pressure. The details are fully given in the *Engineering Record*.

#### STATION INDICATORS.

THROWN not merely into the shade, but into an obscurity so complete as to render them absolutely indistinguishable as are the names of our railway stations by the mass of advertisements closely surrounding them on all sides, an indicator in the trains themselves has become a practical necessity. If this is the case with the regular diurnal and nocturnal *habitués* of the gloomy depths of our Metropolitan Underground, how much more is it not needed by the foreigners and the stranger, and those who for the first time penetrate into those Stygian regions. For some time past, a person travelling in a first-class carriage on the Metropolitan or District line, after passing any station has heard—or perhaps did not hear—two strokes of a gong or bell, exactly similar to a signal, accompanied, or immediately followed, by a distinct whirr resembling that of a piece of clockwork. It is very possible that, although his destination may be several stations beyond that upon quitting which he first heard the signal, he may reach it before understanding what the meaning of the signal is, and no doubt regards it as one used in the working of the traffic. A careful reconnaissance of the interior of the whole carriage, made directly after the two strokes have sounded, will reveal the fact that a cylindrical glass and wooden box is attached to the central part of the ceiling of the carriage. In the box is placed a cylinder, which appears to act very much after the fashion in which that in a perpetual diary registers the days, weeks and months of the year. When the whirring noise ceases the internal cylinder has performed a revolution, or at least so much of a whole revolution as is required, the name of the last station has disappeared from its surface, and that of the next has taken its place. While there is no doubt that the situation up in the roof of the indicating apparatus is a little awkward, yet it is difficult to perceive where else it could be placed to any better advantage. The names of the stations on the cylinder are distinctly visible to everyone in the carriage, and, besides, its position and working renders it nearly altogether free from the chance of being meddled or tampered with.

While our English companies should be congratulated upon their enterprising spirit, our French neighbours have, it must be fairly conceded, "gone one better." But a short time ago the company of Parisian steamboats placed station indicators on their vessels navigating the Seine. Without entering into details, a brief description of the arrangement will not be without some interest. The indicator itself consists of a rectangular wooden box, 2ft. 9in. in height, 1ft. 4in. broad, and 5in. in thickness. In the upper part of the box is placed the clockwork motor, the working parts of which are hidden from view by a small board fixed over them, and carrying on its face the words "Next Station." Upon the signal being given after quitting a station, one of the name-plates, which are all arranged in a series, is detached from its companions, and falls forward. A little manipulation is needed, as, for instance, when the return voyage is commenced, and the plates require resetting. Again, it is sometimes required to take the series of plates completely out of the apparatus, and shift them on board another boat, according to the exigencies of the service. In each small river steamer there are three of these station indicators, one placed in a very conspicuous place on deck near the bridge, one in the forward cabin, and the third in that abaft. All three are perfectly simultaneous, incoherent, and constant in their action, being connected together by a tube

conductor. As frequently with ourselves, so with our neighbours. The difficulty is not so much to invent any particular apparatus or piece of machinery to do a certain work, but the real trouble is to get people to use them. In the very example in question it is no easy matter to make the skippers and crews of the boats use the indicators regularly, and not only when it pleases them to do so.

T. C.

## A ROYAL EGYPTIAN TOMB.

AS a sequel to his discovery of the tomb of King Thothmes III. at Thebes, M. Loret, director-general of the Antiquities Department, has discovered and opened the tomb of Amenophis II., a king of the XVIII. dynasty, who reigned some 1,500 years B.C. Although the jewelry, &c., were rifled from the tomb probably during the XX. dynasty, the mummies of Amenophis and of seven other kings are intact. The tomb is entered, says Sir W. E. Garstin, by a steep inclined gallery, which terminates in a well of some 26ft. in depth, and, this obstacle surmounted, the entrance to the king's sepulchre is reached. In the first chamber the body of a man is found, bound on to a richly-painted boat, his arms and feet tied with cords, a piece of cloth stuffed as a gag into his mouth, and marks of wounds on the breast and head. In the next chamber are laid out the bodies of a man, a woman, and a boy. The king's tomb is in perfect preservation. The roof, which is supported by massive square columns, is painted blue, studded with stars, and the walls are entirely covered with paintings, the colours of which are still vivid. At one end of this chamber is the sarcophagus of the king, placed upon a massive block of alabaster. The sarcophagus is of sandstone, artificially coloured a rose hue, and contains the mummy intact, with chaplets of flowers round the feet and neck. In a smaller chamber to the right are nine mummies, two of them bearing no name, and the others those of the Kings Thothmes IV., Amenophis III., Set Nakht, Seti II., Rameses IV., Rameses VI., and Rameses VIII., who all reigned between about 1500 and 1150 B.C. The tomb is that of Amenophis II., for whom it was built, and is supposed to have been opened later to receive the mummies of the other kings. The floors of all the chambers are covered with a mass of objects—statues, vases, wooden models of animals, boats, &c. The Public Works Ministry has requested M. Loret to remove only the smaller objects, and to leave the mummies and bodies in their present place. The entrance to the tomb will then be built up until next winter, when iron railings may be placed to prevent injury from touching by visitors.

## COLLAPSE OF ROOF.

FROM Ontario comes the news of another building disaster—this time, a large music-hall at Oshawa, Ontario. The building was of brick, three stories high, and, as in the case of the hall at London we noticed some time ago, the assembly hall was on the upper floor. There was a flat roof, 100ft. by 75ft., which collapsed and fell to the second floor, completely covering the seats of music-hall. Fortunately, the roof fell early in the morning, or the consequences would have been terrible, as in the evening an entertainment was to have taken place in the hall, which is capable of holding 800. The cause of the fall is attributed to the weight of snow on the roof, which was flat. The roof is said to be a new one. The *Canadian Architect*, from which we take these particulars, suggests "that if the title 'architect' was restricted to persons who had passed a qualifying examination, as is now the case in the province of Quebec and the State of Illinois, the public would at least be enabled to know who were qualified to put up safe structures, and could then decide accordingly." We are afraid these buildings are often undertaken as a speculation, and that the owner or company who build them have plans prepared that have not been submitted to any local or municipal authority. Public buildings to hold large numbers of persons ought to be especially looked after, and the only way to secure safety is to submit the designs to some authority before they are allowed to be carried out. A room 100ft. long by 75ft. wide is a large area to be floored and roofed, and particular attention ought to be given to the scantlings of timbers, the size and testing of iron girders, and the construction of roof, whether

of timber or iron. We are not told what the roof was constructed of in this instance; no doubt the rafters or ties were insufficient to sustain the extra weight of snow.

## MANTEL DECORATION.

[WITH PHOTOLITHOGRAPHIC ILLUSTRATIONS.]

THIS is a design for mantel decoration of simple construction, in which a number of different materials are used on a structure of plain oak. The main enrichment is gesso-work, coloured a pale sea-green, with gold used lightly, as a background, adding a certain piquant richness to the scheme of tender brown and green afforded by the natural oak and coloured gesso. The idea of cupboards and the accidental colour-note of a line of books, and perhaps one or two pieces of old blue and white china, help to give the whole the pleasant effect of being in some degree a useful part of home-life. The grate is surrounded by 3in. square *repoussé* copper plates set in cement, having at sides pilasters of oak 7½in. wide and 5½in. deep to wall. The horizontal band immediately beneath 3½in. ogee moulding supporting mantelshelf is 10½in. wide, having four sunk panels in gesso, coloured green on gilded background. The portion of this band coming between pilasters is one board set on wall, the front surface cut away in four places to leave the three 3in. wide vertical bands projecting ½in. Above mantelshelf a lighter treatment is adopted, the main support of the structure being the 2in. square pieces of wood with simple moulded base, one placed at each corner, the two at back fixed to wall. The space at ends between these supports is filled, up to the china-shelf over cupboards, by a wrought-iron grille, to the centre of which is fixed the bent rod of stouter iron supporting lower candle-brackets. The strap-hinges to cupboards of hammered iron. The ornament supporting upper candle-brackets in centre of frieze of overmantel in gesso (high relief) on shaped wood. G. M. ELLWOOD.

The St. Pancras Vestry have received a letter from the Home Secretary with reference to the Workmen's Compensation Act, 1897, which comes into operation on the 1st of July next, stating that "he is advised that electric-lighting works, where electricity is generated by the use of mechanical power and is supplied to consumers, are factories within the Factory and Workshops Acts, and therefore the Workmen's Compensation Act will apply in all such cases."

A new United Presbyterian church at Markinch, Fife, was opened yesterday (Thursday). Built on the Balbirnie estate, to designs by Mr. Hippolyte J. Blanc, R.S.A., Edinburgh, the church is in the Early English style, and consists of a nave with one transept and one aisle. The church is seated for from 450 to 500, and the adjoining hall will hold fully 100. The total cost has been £2,800.

Major Dransfield, head of the well-known firm of railway contractors at Manchester and Liverpool, died on Tuesday night at Harrogate at the age of 70. His home was at Sheffield; but he formerly lived at Bootle, where he held a commission in the Artillery Volunteers.

Hepworth Church, Suffolk, was completely destroyed by fire on Monday morning. Nothing but the bare walls and tower were left standing. The village is about eight and a half miles from Finningham station. The church was a quaint structure, dedicated to St. Paul, and stood on high ground, the district being notable for one of the highest ridges in the county. The building was one of rubble and stone, chiefly in the Early English style, with thatched roof; it comprised chancel, nave, south porch, and a western tower, containing a clock and five bells. The restoration and reseating dates from 1855; a new organ was erected in 1892. There were 280 sittings.

Probate of the will of Mr. Edmund Tonks, of Packwood Grange, Knowle, who died on Feb. 7 last, aged 74 years, leaving personal estate of the value of £27,360 3s. 1d., has been granted to the acting executor, his son, John Edgar Tonks. The testator bequeathed his portrait, by the late Frank Holl, R.A., to the Lord Mayor and citizens of Birmingham.

At a meeting of the Bristol Association of Clerks of Works and Builders' Foremen, Mr. W. Kidwell, who is retiring from the duties of secretary to the association, was presented by the members with a valuable case of drawing instruments, in acknowledgment of the very able and courteous manner in which he had discharged the duties of secretary from the commencement of the society till the present time. Mr. J. N. Pike made the presentation on behalf of the members.

## OBITUARY.

THE death of M. CHARLES YRIARTE, the well-known art critic, took place on Wednesday night in last week after a few days' illness. Of Spanish extraction, he was born in Paris in 1832, and studied architecture under Constant Dufeux. In 1856 he was appointed architectural inspector of the Vincennes and Vesinet Asylums, and afterwards of the Opera, but did not long retain that post. In 1859 he accompanied O'Donnel's expedition to Morocco as artistic correspondent for the *Monde Illustré*; in 1866 in the same capacity he witnessed the liberation of the two Sicilies, and ten years later he acted as secretary to General Vinoy during the Franco-German war. He next wrote for About's paper, the *XIXième Siècle*; but in 1874 to 1876 he travelled in Istria, Dalmatia, Montenegro, and the Balkans, whence he sent articles to the French Press. In 1879 Jules Ferry, unsolicited, appointed him an inspector of fine art, in which post he assisted in organising the 1889 exhibition, and in 1881 he succeeded Gruyer as inspector-general. He was curator of the gallery of Sir Richard Wallace, who was guided by him in the purchase of pictures. He was the author of numerous works of travel and artistic biography and criticism. He was himself also an artist, and exhibited water-colours in the Salon.

THE death took place at Peterborough, on Easter Monday, of Mr. Alderman JOHN THOMPSON, J.P., the well-known church builder. Mr. Thompson, who was seventy-four years of age, had been actively engaged in business up to a few months ago, when a trip to Ireland, where he was engaged in restoring a church, resulted in an attack of yellow jaundice from which he never recovered. He was three times Mayor of his native city, and he was chosen to act in that position in the Diamond Jubilee year. He was the son and successor of the late John Thompson, who some 78 years ago commenced the restoration of Peterborough Cathedral, under Edward Blore, and he was builder of many churches and public buildings, including Glasgow University, the Royal Holloway College at Egham, the Royal College of Music, the Grocers' School, and the Church House at Westminster, on which his men are still engaged. He rebuilt the lantern tower of Peterborough Cathedral, and, under the late Mr. Pearson, R.A., has been engaged in its restoration for many years, while he has also carried out important works of restoration with the late Sir Gilbert Scott and Mr. J. L. Pearson at Salisbury, Lincoln, Winchester, Bangor, Chester, Ripon, Norwich, and Lichfield Cathedrals. He also rebuilt the famous spire of St. Michael's, Coventry, and has carried out various works in the Houses of Parliament. After restoring Viscount Peel's house at Sandy during his Speakership of the House of Commons, Viscount (then Mr.) Peel entertained the workmen to dinner at Peterborough, and spoke in high terms of praise of the wood-carving executed at Mr. Thompson's works, where all the carving of the new choir stalls at Peterborough was done. We gave Mr. Thompson's portrait in our issue of April 4, 1890. The funeral service will take place in Peterborough Cathedral this (Friday) afternoon at two o'clock.

## CHIPS.

The Bournemouth Corporation have granted Mr. Keene, their building inspector, an honorarium of £50 for extra work performed out of office hours during the past two years.

Gosling's branch of Messrs. Barclay's Bank in Fleet-street is about to be rebuilt from the designs of Mr. Arthur Blomfield, jun. Operations for the demolition of the old premises have been commenced this week.

A meeting of the Haddington Town Council was held on Thursday night in last week to consider the new bridge scheme. A motion that Messrs. Belfrage and Carfrae's report and recommendations be adopted, on condition that the cost to the ratepayers does not exceed £5,000, was rejected after a long discussion by a majority of one.

There will be an inquiry at Winchester to-day (Friday), by Mr. Boulnois, an official from the Local Government Board, as to a loan of £800 for purchasing the site for the public baths of the Old Greyfriars Monastery.

At a meeting of Kirkcaldy Town Council on Monday, a long discussion took place in connection with the building of a new bridge, to cost £14,340, between Pathhead and Kirkcaldy, and eventually it was decided to proceed with its erection.

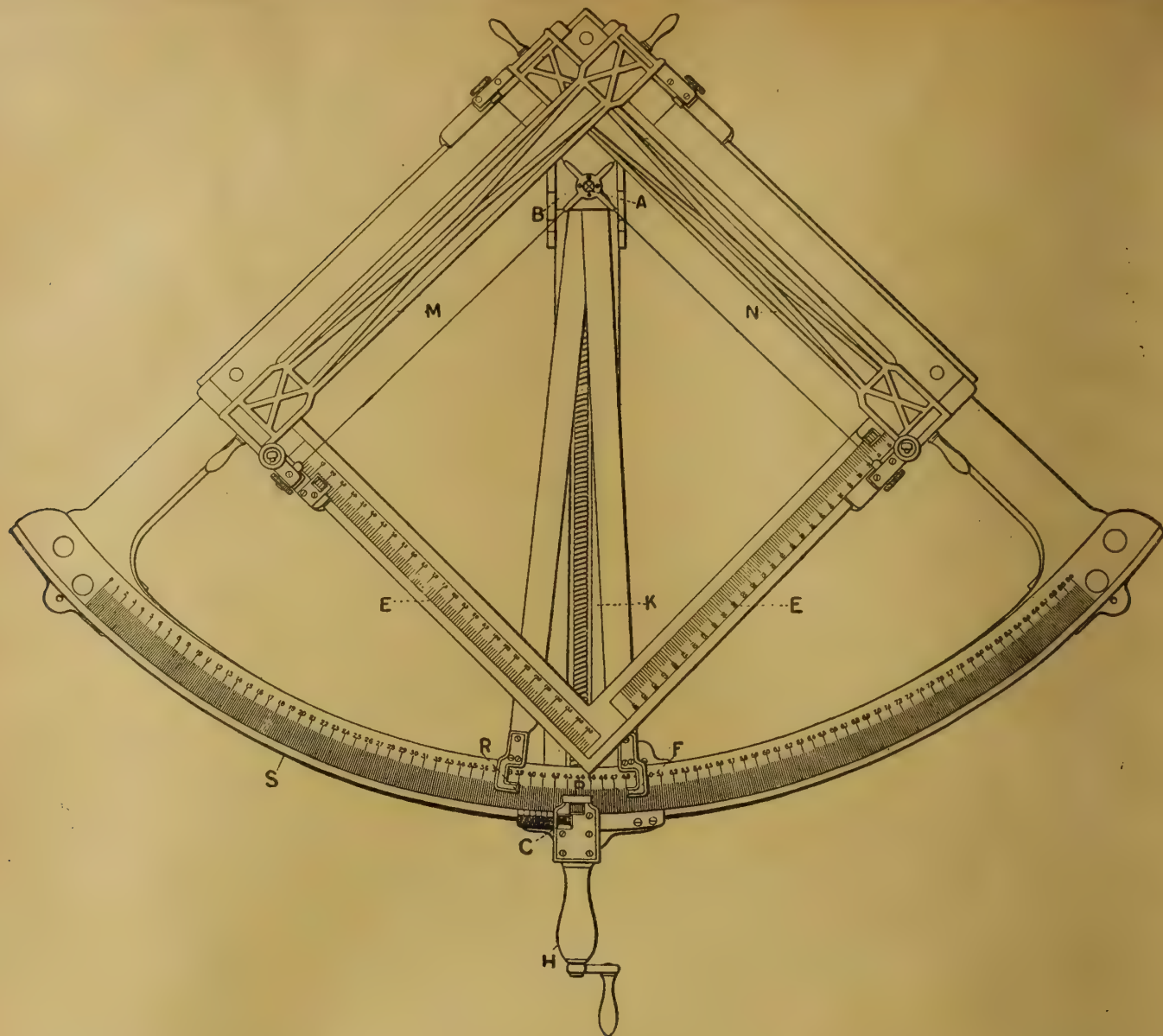

#### A BEVEL-GEAR COMPUTING MACHINE.

THE accompanying illustration shows a very interesting machine or instrument for the determination of the various angles required in the construction of bevel gears. It is the design of Mr. James Gleason, of the Gleason Tool Company, Rochester, N.Y. As is well known, the Gleason Company does a large business in planing bevel gears to order, and the tiresome and laborious repetition of the calculations necessary to determine the various angles led Mr. Gleason to consider the advisability of making an apparatus for the graphical determination of the angles, and this device is the result.

A graduated quadrant, S, is divided into degrees, with appropriate subdivisions. A swivelled arm, K, terminates in a handle, H, the centre of motion being at the centre of the quadrant. The crank at the end of the handle actuates the screw shown, which operates the sliding-block B along the arm K. The block B carries three swivelled guides, which embrace corresponding radial auxiliary arms, two of which will be seen in front of K, while the third is in the rear, and out of sight. It terminates below in the auxiliary divided arc C. As the block B is moved upward toward the swivel stud, the three auxiliary arms are separated, while as B is moved downward, a reverse movement of the arms is made.

Slightly nearer the observer than the arm is the rectangular frame E, having edges which guide the two slides M and N. Each of these slides carries a strained wire, which passes freely through the arms of a star, A. The movements of the slides thus give corresponding movements to the star, which can thus be made to occupy any position within the rectangular frame. Accurately divided scales are mounted on two sides of the frame E, while the slides M and N have index marks for setting the slides to the divisions on the scales. These divisions are for the number of teeth in the two gears of a pair respectively, the range running

from mitre gears to those having a ratio of 10 to 1.

To illustrate the use of the machine, assume a pair of wheels having 13 and 78 teeth. Slide M is so placed that its index mark stands at division 13 on its scale, and slide N is placed at division 78 of its scale, star A moving to a position determined by these settings. Arm K is now swung about its centre, and block B is adjusted along the arm until a circular button on its front face is brought to match a corresponding button on the rear of the star. These buttons pass close to one another, and the adjustment is accurately made by matching them with the fingers.

The settings are now complete, and locking the arm K in position the readings for the pinion can be taken off. Index mark P gives the pitch cone angle, F the face cone or blank angle, R the root cone or cut angle, and C the angle which the sides of a tooth make with one another, or the "caliper angle," as it is called in the Gleason shops.

For the 78-tooth gear the setting is repeated, but reversed, slide M being now set to 78 and N to 13. The button on block B is adjusted to the one on the star, as before, when the readings give the angles required, as before, but for the gear instead of the pinion. For a pair of mitre gears, of course, single setting only is required.

It will be observed that the pitch of the tooth is not a factor so long as uniform proportions of teeth are used—which, in fact, is the fundamental idea of the machine. Two pairs of gears of the same number of teeth, but of different pitches, may be considered as being parts of the same cones, but with the coarser pitch gears located farther from the apexes of the cones, from which consideration it is plain that the various angles will be the same in both sets.

The size of the machine and divisions of the scales are such that the angles can be read to within one minute of an arc.

As used in the Gleason works, the machine is mounted permanently on the wall, where it can be consulted as desired and as occasion arises. We

judge from what we saw of it that its usefulness is quite up to its ingenuity—which is saying a good deal.—*American Machinist.*

#### CHIPS.

Sir W. B. Richmond, R.A., has written to the *Times*, expressing his regret that owing to absence from England he had no opportunity of adding his name to those of his colleagues who signed a letter "in which was expressed just admiration for Mr. Shaw's New Scotland Yard, a building which does honour to the great architect who designed it and to the city in which it stands."

The urban district council of Exmouth decided at their last meeting to give a month's notice to terminate his engagement to Mr. Beswick, their surveyor.

Mr. Augustus Laver, an architect who died in Alameda, Cal., March 23, had designed some prominent public and private buildings in San Francisco and elsewhere in the Pacific States.

The new museum at Keswick, erected in memory of Thomas and Henry Hewitson, the donors of the Fitz Park, was opened on Tuesday. It has been erected from plans by Mr. Thomas Hodgson.

The finance committee of the Camberwell Vestry has recommended that a grant of 300 guineas should be made to the family of the late surveyor, Mr. O. S. Brown, to be applied for the benefit of the younger children, under the direction and discretion of the finance committee.

The Hygienic Congress was opened at Madrid on Saturday. The delegates were welcomed by the Minister of the Interior.

A branch line of railway is about to be constructed from Fort George station to the village of Campbelltown, Ardersier, a distance of two miles. The execution of the contract, which has been secured by Messrs. Chisholm and Co., Dingwall, will be comparatively easy, as the ground is nearly level.

CONTENTS.

Changes and Extras .....	515
Model Specifications.—VIII. ....	515
BUILDING NEWS Designing Club .....	517
Wrought Iron and Steel in Constructional Work.—XXXVII. ....	518
Imitation Varnishes .....	519
The Electricity Supply of London .....	519
Electric Lighting Notes for Architects.—XXI. ....	520
Sanitary Work.—V. ....	522
Systems of Steam-Heating Buildings .....	523
Comparative Strength of Riveted and Bolted Joints. ....	523
Discoveries of Buddhist Remains in India .....	523
St. Mary's Cathedral, Edinburgh .....	523
The Working Value of Fuels .....	524
Replacing Fronts .....	524
Station Indicators .....	524
A Royal Egyptian Tomb .....	525
Collapse of Roof .....	525
Mantel Decoration .....	525
Obituary .....	525
A Bevel-Gear Computing Machine .....	526
THE BUILDING NEWS Directory .....	IX.
Our Illustrations [.. .. .]	527
Engineering Notes .....	546
Building Intelligence .....	546
Competitions .....	547
Professional and Trade Societies .....	547
Correspondence .....	548
Intercommunication .....	548
Legal Intelligence .....	549
Our Office Table .....	549
Meetings for the Ensuing Week .....	550
Trade News .....	550
Latest Prices .....	550
List of Competitions Open .....	551
List of Tenders Open .....	551
Tenders .....	553

ILLUSTRATIONS.

- RHOS ABBEY HOTEL.—CHIMNEYPIECES, BOLSOVER CASTLE.—
- MANTEL DECORATION IN OAK.—BALHAM LIBRARY.—
- DESIGNS FOR A CONVALESCENT HOME.—WHITBY ABBEY.—
- THE CASINO, VILLA PAMPHILI-DORIA, ROME.

Our Illustrations.

RHOS ABBEY HOTEL, RHOS-ON-SEA, NORTH WALES.

This hotel is now in course of erection upon a site familiar to Welsh historians, known as Rhos Abbey, commanding extensive sea views towards Colwyn Bay, Abergele, and Rhyl, with some splendid mountain scenery in the background. The hotel also overlooks the ancient Fishing Weir, which was in existence previous to Queen Elizabeth's time. The plans have been prepared by Messrs. Booth, Chadwick, and Porter, architects, Manchester and Colwyn Bay, and the work is being carried out under their supervision.

NATIONAL SILVER MEDAL DRAWINGS: CHIMNEY-PIECES, BOLSOVER CASTLE.

MR. ALFRED B. ILLSTON has sent us the following brief history of Bolsover Castle, to accompany his prize-medal series of drawings of the famous Renaissance chimneypieces, which form one of the main features of interest in this very interesting Derbyshire building. Bolsover, a small county town about six miles east of Chesterfield, is situated in what is now a busy mining district. So rapidly has this industry developed that six different pit-heads can be seen from the battlement of the tower, from which in past days a grand and extensive view of hill and dale, together with the noted seats of Haddon and Hardwick, were visible. Yet in other days it had a very different history, and for a period of about five centuries it was a busy market-town, renowned for its manufacture of tobacco pipes (which occupation still lingers in the district), spurs, and buckles; so celebrated, indeed, were the Bolsover buckles for their elasticity, that it is said a loaded cart's wheel could pass over them without in any way affecting their shape. At the time of Domesday, the manor of Bolsover belonged to William Peverell, who is supposed to have built the first castle. In 1189 we find the castle, together with the manor, given by Richard I. to his brother John on the occasion of his marriage. During the Magna Charta struggle, in the 18th year of his reign, John issued a mandate to the governor of Bolsover to fortify the castle and hold it against the rebellious barons, and this no doubt was the period when the fortifications, which are still visible about the village, were established. In 1215 the castle was in the possession of the barons, but was taken from them by assault for the King (John) by William de Ferrars, Earl of Derby. In 1456 the Earl of Richmond died possessed of it, and in 1514 it was granted to Thomas Howard, Duke of Norfolk, on the

attainder of whose son it once again reverted to the Crown. When Edward VI. bestowed it on the Earl of Shrewsbury, the ancient fortress was fast decaying, and so little pains were taken to preserve it, that by the time the seventeenth century dawned it was a mass of ruins. In 1613 the Earl of Shrewsbury sold Bolsover to Sir Charles Cavendish, and in the year of his pure chace he cleared the tottering ruins of the Norman keep, and on the same site the foundations of the new house or present castle were laid. This building is situated on the bank of a high limestone rock, at a considerable elevation above the valley. It is a square, lofty fabric of brown stone, having a tower at each angle, the one at the N.E. corner being of much larger dimensions; in the centre is a cupola, giving light to rooms below, and a turret at each corner to serve as protection for the soldiers on guard, or for watch-towers. This building, however, was evidently not really built as a fortress, but rather for a domestic residence. The architect is said to have been Huntingdon Smithson. The entrance from the village appears to have been by a roadway or terrace formed by the edge of the rock to a flight of steps leading into a high inclosed small courtyard, in which are two small outhouses. Over the entrance-door is a figure of Hercules supporting on his massive shoulders the heavy balcony above. By this door we enter the Hall. It has an elaborate groined ceiling, which springs from two circular stone pillars. The floor is diaper pattern, interlaid with black and grey marble. The walls are wainscoted with black oak, and decorated with gilt ornamentations of the period. In this apartment is the beautifully decorated mantle, composed of yellow sandstone, white and black marble and alabaster, bearing at the top the supporters and coat of arms of the Cavendish family, with a canopy of white marble. From this we pass into the "pillar parlour." This is an apartment of similar construction, being 78ft. by 33ft.; it, too, has an arched roof supported by a central pillar, round which is a plane circular dining-table. The wainscoted walls are also decorated with gilt devices, and at each end of the room are painted very delicate frescoes. From these rooms you pass up a stone staircase to a corridor leading into the various rooms, from which the illustrations are gathered. The largest of these rooms is the Star Chamber: this is a room 220ft. by 28ft., with its decorated ceiling of blue and gold, its rich chimneypiece composed of alabaster, sandstone, blue and grey marble, bearing the full coat-of-arms of the Cavendish family, and being splendidly decorated with side panels of war trophies, as shown in the drawing on the left-hand side. The walls are decorated with portraits of the Twelve Cæsars; the floors are of plaster, reminding us of the time when rushes were in use as floor-coverings. From this room you pass along the corridor, up one or two stone steps leading into various smaller rooms, which, from their appearance, may have been used as sleeping apartments. In the rooms are smaller pointed corner mantels lavishly decorated with ornamentations of the time, with bosses of various coloured marble. The mouldings are of alabaster and sandstone inlaid with black marble. We shall illustrate these shortly. There are other rooms, one of which must have been the drawing-room, being 39ft. by 33ft., and having a small ante-room in one corner. In this apartment is a large semi-octagonal mantle composed of sandstone and alabaster, bearing musical and literary devices on the jambs. The floor is of plaster, the walls wainscoted, with recesses and shelves at intervals; but which may have been placed there at a later date, as the place is said to have been converted into a museum. From this room you go down the passage to a room of similar dimensions. This is a plain, square apartment, with plaster floor, wainscoted walls, and also having a small ante-room at each side of the chimneypiece, which is placed in the centre at the far end of the apartment. This chimneypiece, herewith illustrated, is rectangular in plan, and bears small shields with the constituents of the Cavendish arms. In the centre is a square slab of slate, with a guilloche moulding running round and decorated with pieces of inlaid black marble, supported at each side by a scroll of the Tudor style. Above this is a small niche, with a semicircular top, which perhaps has been the resting-place of some family relic in bygone times. Hitherto I have only spoken of that part of Bolsover Castle called the "Little House," to distinguish it from

the more magnificent structure adjoining—a range of apartments now roofless and rent into fissures, of which only the outside walls are standing. It is thought that this long block of buildings was erected at the time of the restoration of the keep. But Diepenbeck's view of Bolsover (1652), however, decides the point of their previous existence, and that they were built before the time of the Civil Wars is more than probable, as otherwise there would have been no room at Bolsover for the splendid entertainment which the Earl of Newcastle gave to King Charles, the Queen and Court, and all the gentry of the country. It now belongs to the Duke of Portland, whose family derived it in the female line from the Newcastle Cavendishes. The whole pile is now fast wearing away. Trees are growing in some of the deserted apartments, and ivy creeps along the walls, although the place wears little of the picturesqueness of decay. Two views of the Castle were given in the BUILDING NEWS for Aug. 24, 1888.

MANTEL DECORATION.

(For description, see p. 525.)

BALHAM LIBRARY.

THIS branch library, which will be opened in a few weeks' time, is being built in two sections, the first of which is just completed; the magazine-room being now used as a lending library. The library is under the control of the Streatham Libraries Commissioners. The materials used in construction are red bricks, Portland stone, and green slate, while all arches are done in a specially made red tile. The builder is Mr. T. Wallis, of Balham; Mr. G. Bull being clerk of works. Considerable difficulty was experienced in the foundations as the building was on the site of an old gravel-pit, and piers (on which the building stands) had to be carried down very deep. The site was presented to the Commissioners by Mr. Henry Tate, J.P., of Streatham, and the library is being erected by them as a branch of the Streatham Library, which will be the central one of several branches.

"BUILDING NEWS" DESIGNING CLUB: A CONVALESCENT HOME.

(For description and awards see p. 517.)

WHITBY ABBEY, YORKSHIRE.

THE accompanying drawings, which are strictly accurate in every detail, and have been measured from the building itself, illustrate the choir arcading of Whitby Abbey, which is recognised as being one of the finest examples of (13th-century Gothic or) Early English architecture. The stone is from local quarries, and the arcading now remaining is in splendid preservation as regards detail. Characteristic of this period of architecture are the mouldings, which are both effective and graceful in outline. The triforium stage is surmounted by a graceful five-arched clerestory arcading, which, by the diminishing proportions both in detail and general outline, and the figured terminals to the arches, distinguishes the composition, and gives a pleasing effect. The main arcading is also profusely moulded, and of graceful proportions, the whole constituting a composition worthy of study by those interested in architecture. This ruin stands on a commanding cliff overlooking the North Sea, which greatly enhances the beauty of its architecture.

ARCHIBALD H. WINTERBURN.

THE CASINO, VILLA PAMPHILI-DORIA, ROME.

ALESSANDRO ALGARDI was the architect of this well-known Casino. The grounds were laid out by the same artist, acting conjointly with Antinori. The estate was the gift of Innocent X. to Olimpia Maidalchini, his brother's wife, in 1650. The gardens which form so prominent a feature in all the views on this side of the city, add materially to the beauty of the spot. They are laid out in avenues, terraces, and plantations, dominated by the lofty pines which give the place so conspicuous a character in the landscape. Garibaldi's republican troops occupied the casino and grounds in 1849, and the great emancipator maintained his position here for many weeks against the concentrated attack of the French army. Needless to say during the onslaught which ensued the gardens, terraces, statues, and buildings were much injured. The drawing, which we have borrowed from our contemporary the *American Architect*, gives an admirable idea of the gardens now as seen close to Algardi's Casino.

**WHITBY ABBEY, YORKSHIRE.**

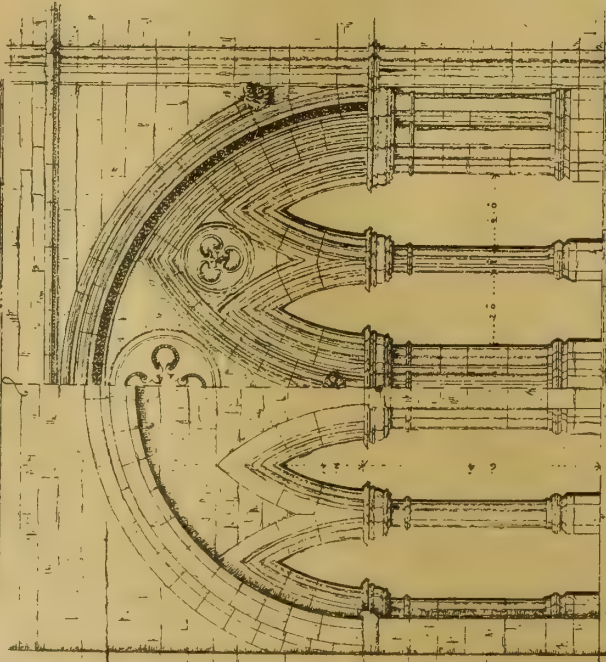

EXTERIOR ELEVATION OF TRIFORIUM AND INTERIOR ELEVATION OF TRIFORIUM.

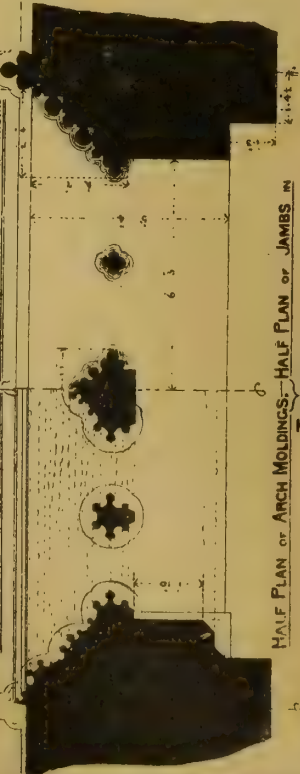

HALF PLAN OF ARCH MOLDINGS—HALF PLAN OF JAMBS IN TRIFORIUM.

**DETAILS OF ONE BAY OF CHOIR, SOUTH SIDE.**

*of H. M. ...*

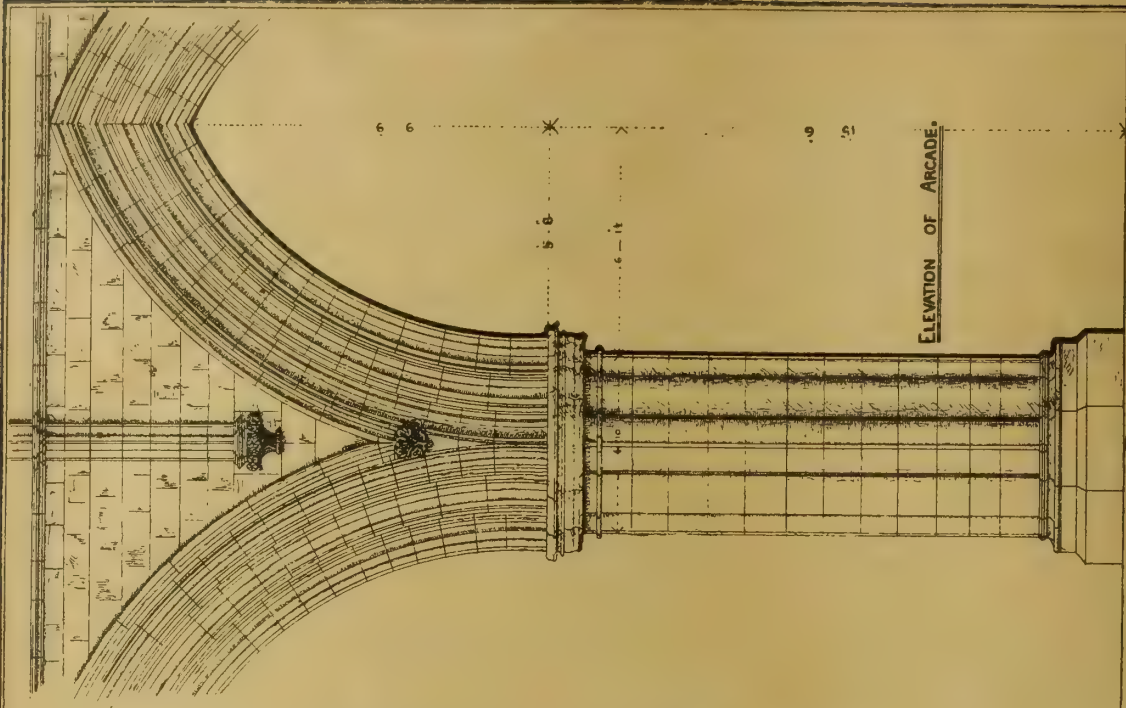

ELEVATION OF ARCADE.



HALF PLAN OF BASE AND ARCH MOLDINGS.

SECTION THRO: TRIFORIUM AND ARCADE.







GROUND PLAN

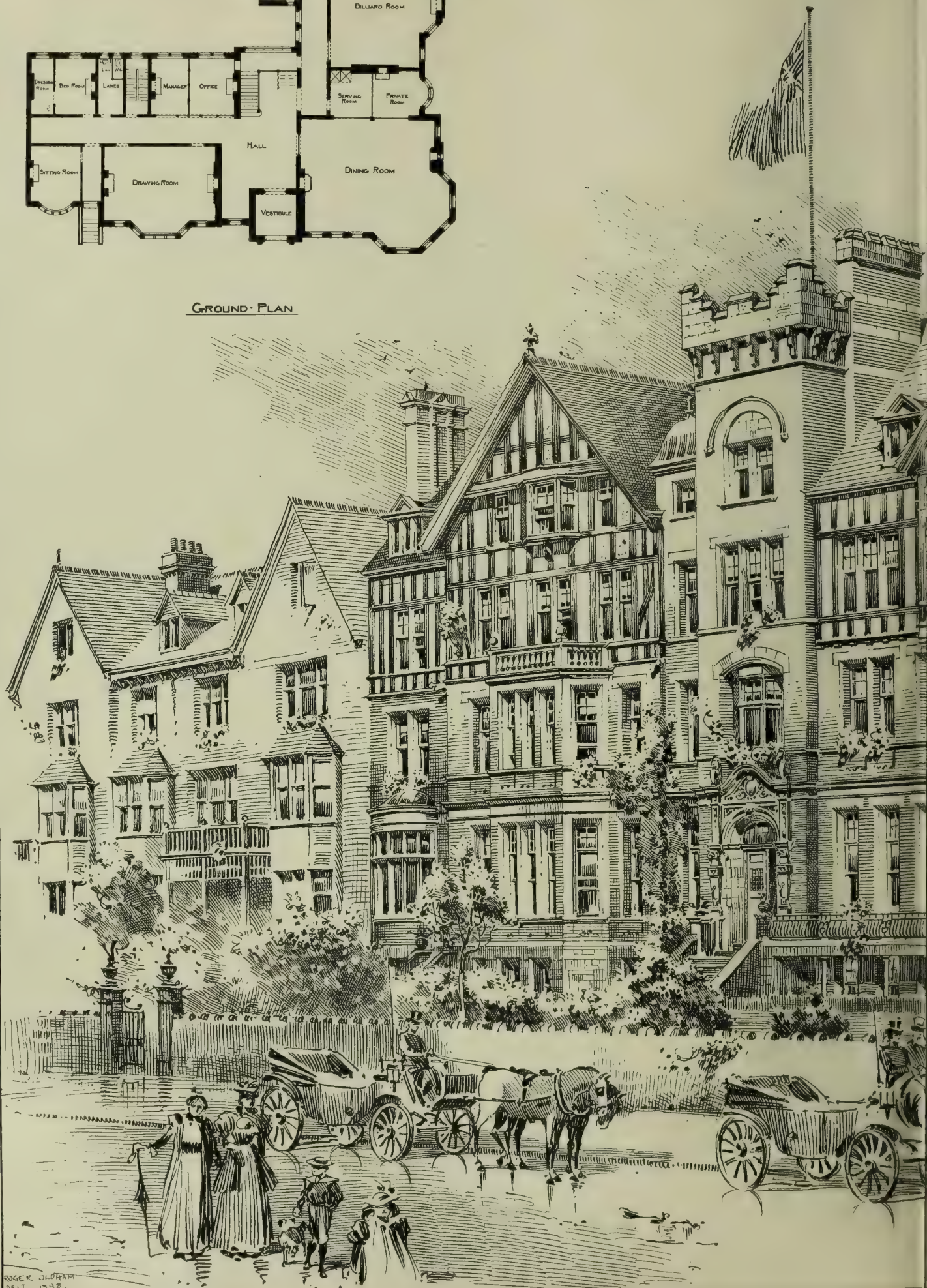

RHOS ABBEY HOTEL  
RHOS-ON-SEA NORTH  
WALES. MESSRS. BATH CHADWICK  
& PORTER ARCHITECTS.



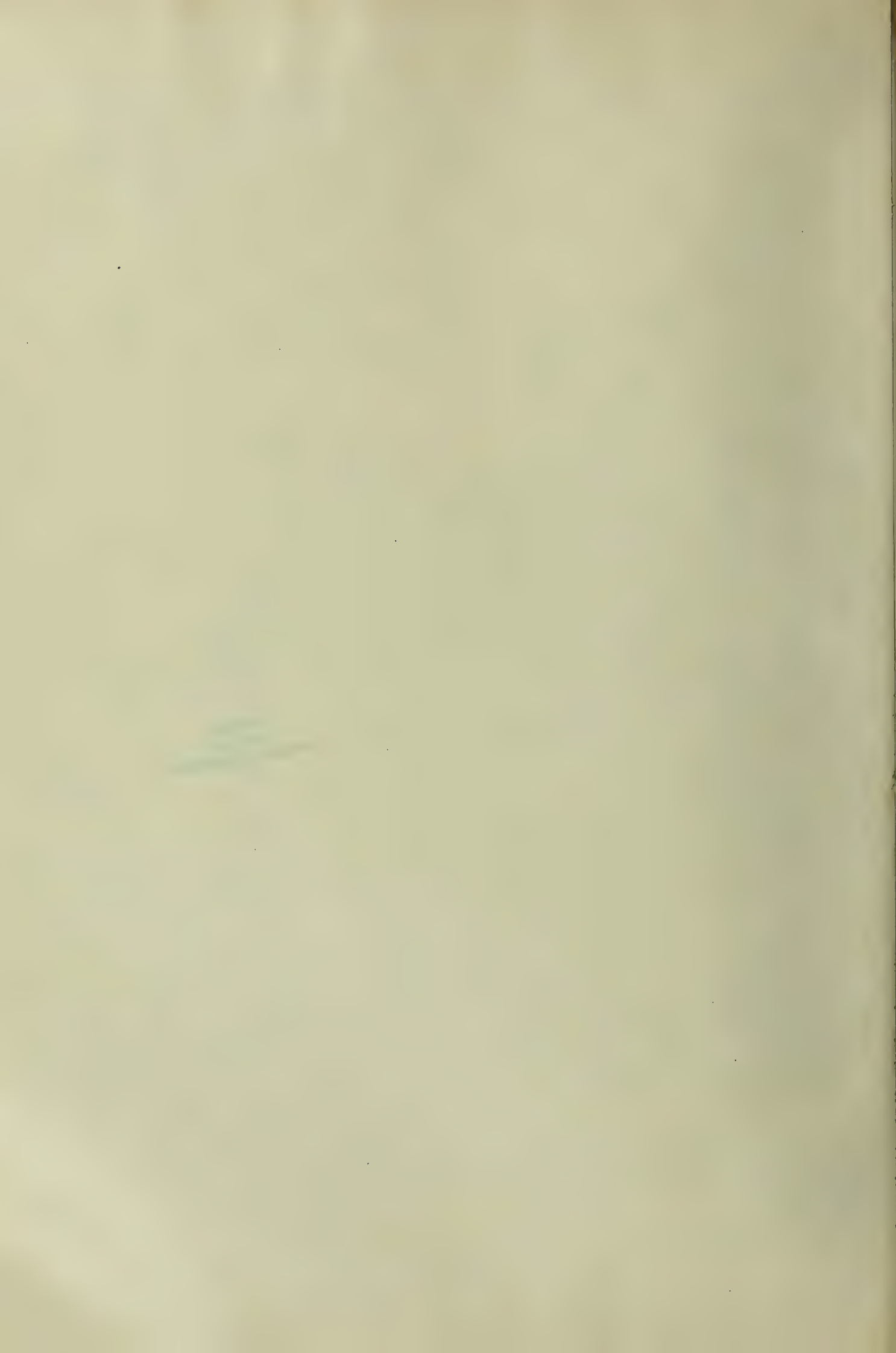



NATIONAL SILVER MEDAL

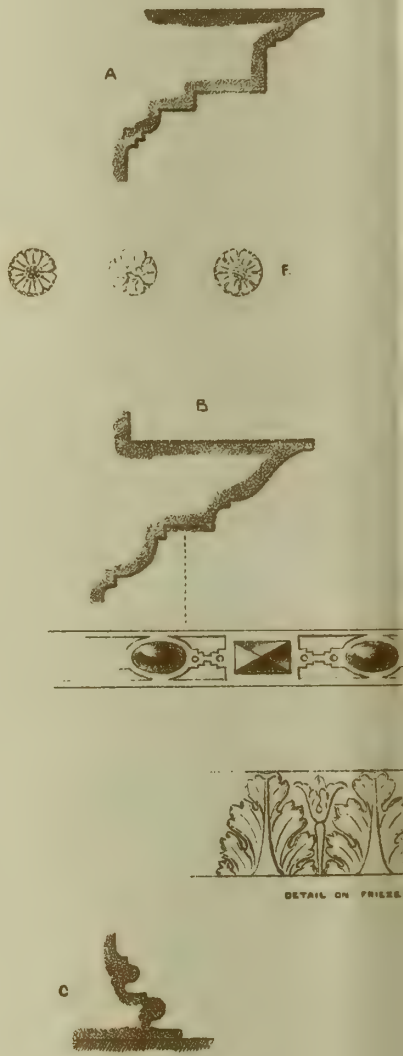

DETAIL ON FRIeze



SIDE PANEL



SCROLLS 1888

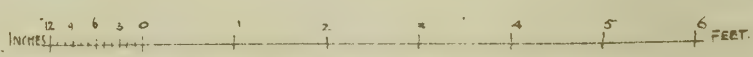
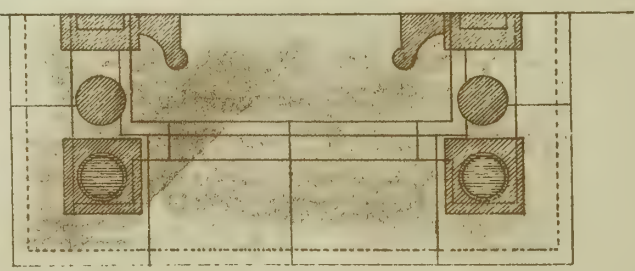

Wolsover Castle From Measurement.

ALABASTER:- MOULDINGS, CAPS TO PILLARS, PANELS AND ARMS.  
GREY MARBLE:- PILLARS AND PANELS.

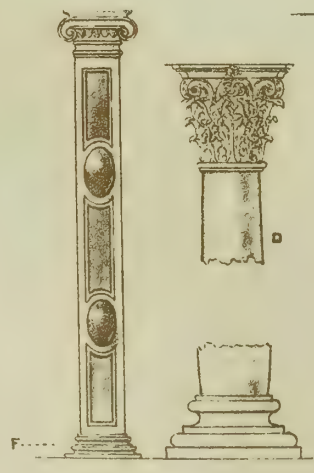

F

DRAWINGS BY A. B. ILLSTON.

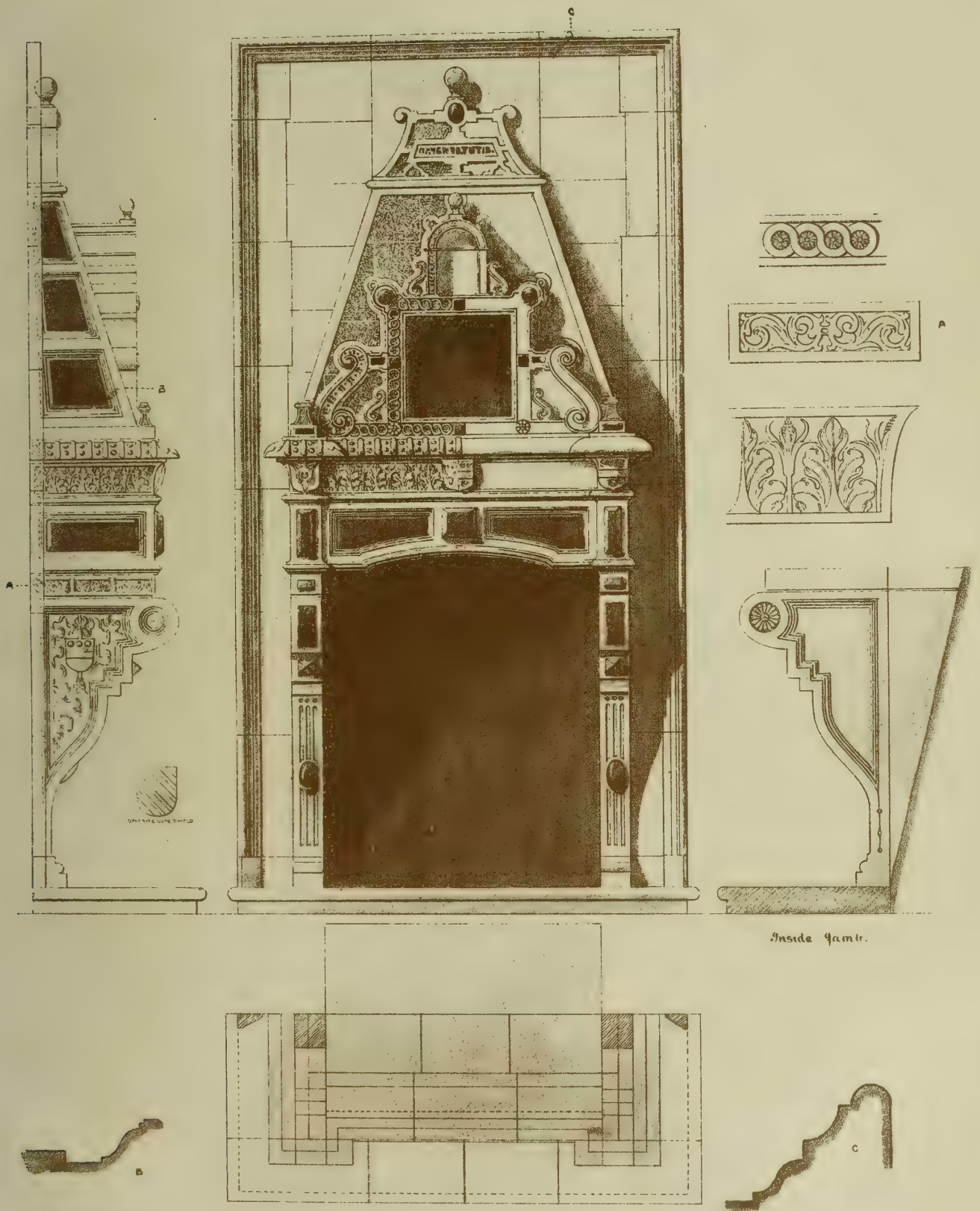

Halsever Castle.

From Measurement.

GREY AND BLACK MARBLE PANELS AND SANDSTONE

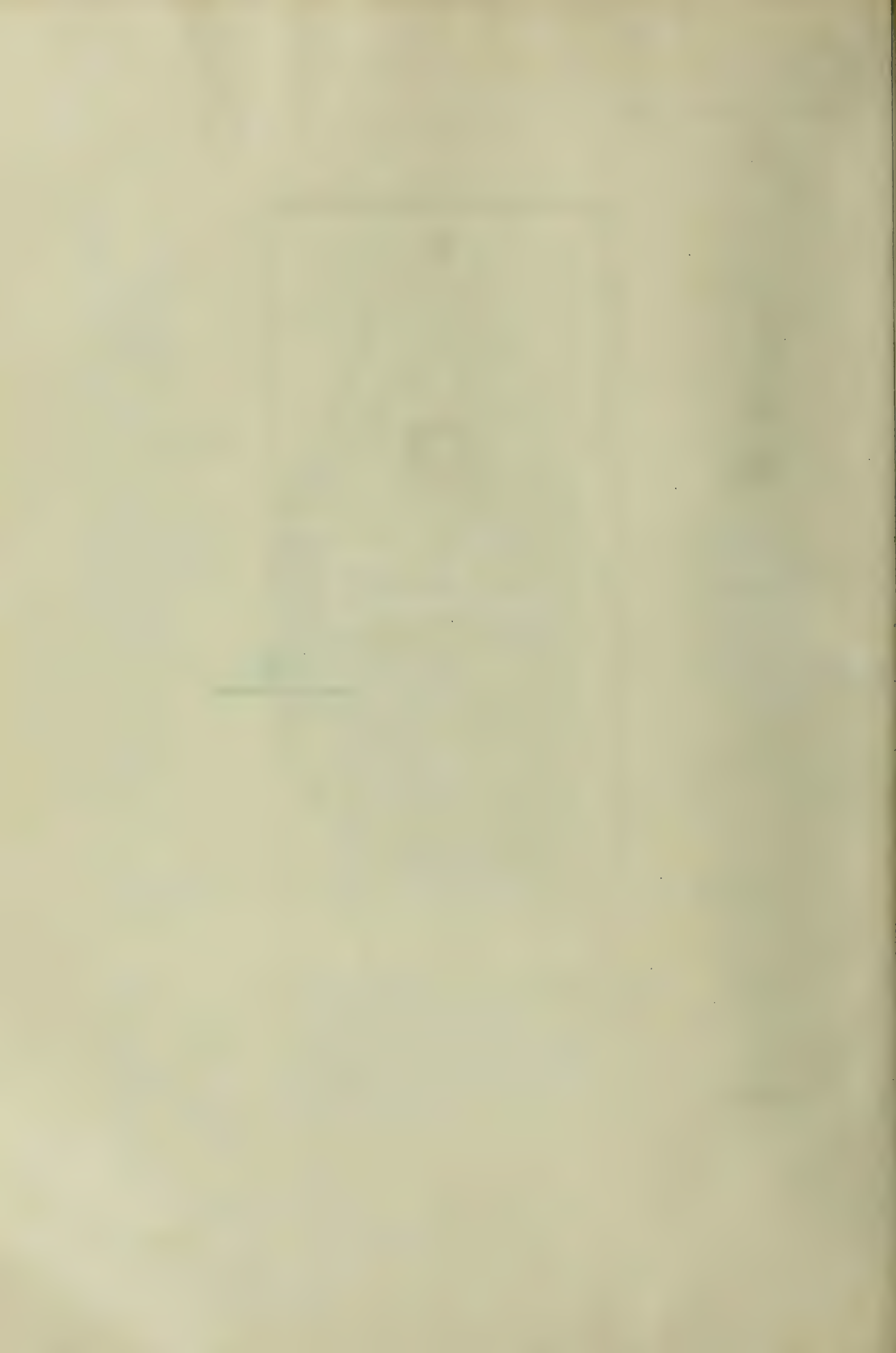





PLAN  
DESIGN FOR  
A  
COTTAGE  
HOME  
BY  
"DACS"

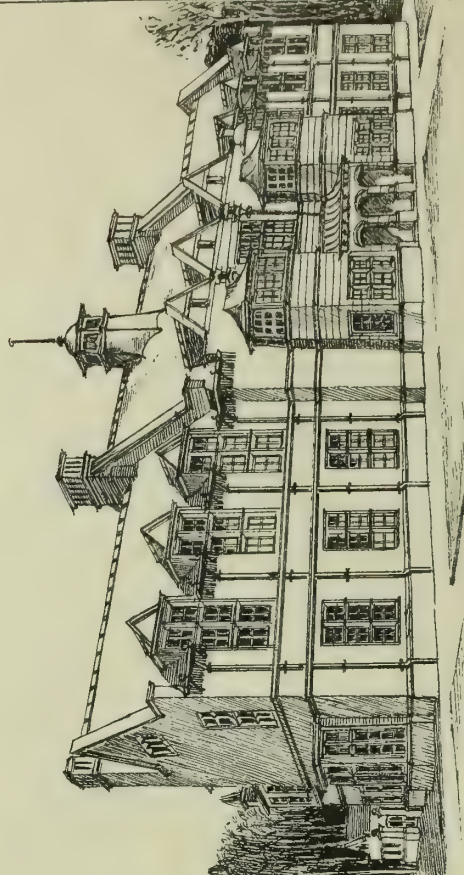

Street View

SPIDER VIEW

PLACED SECOND

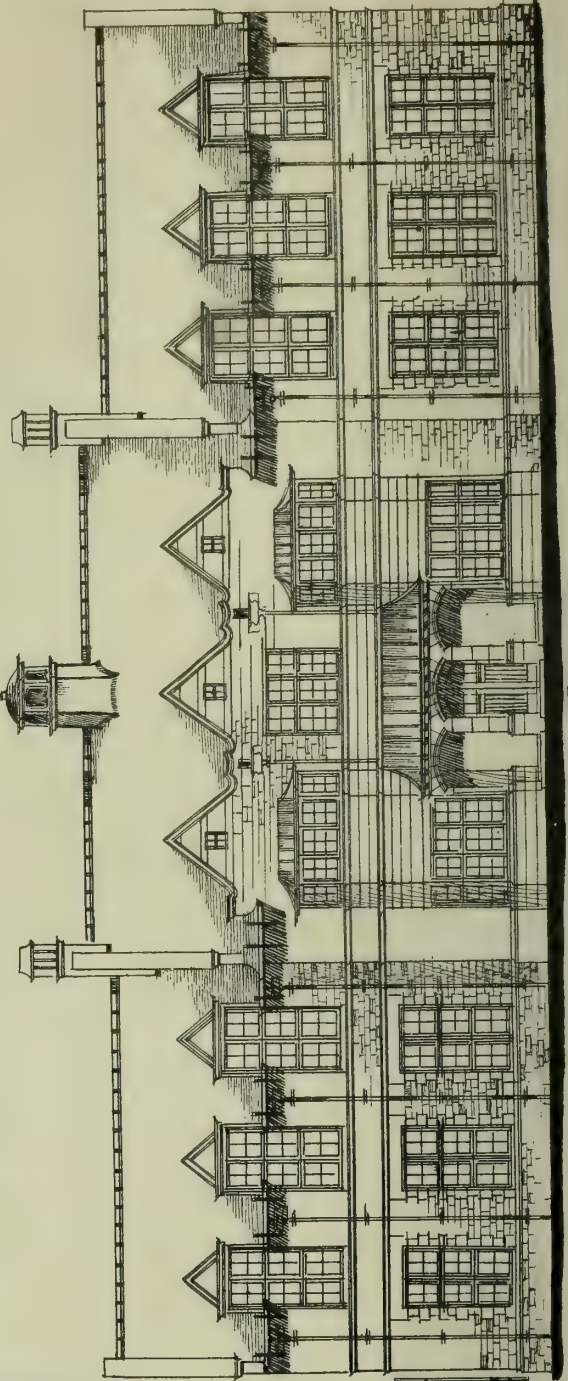
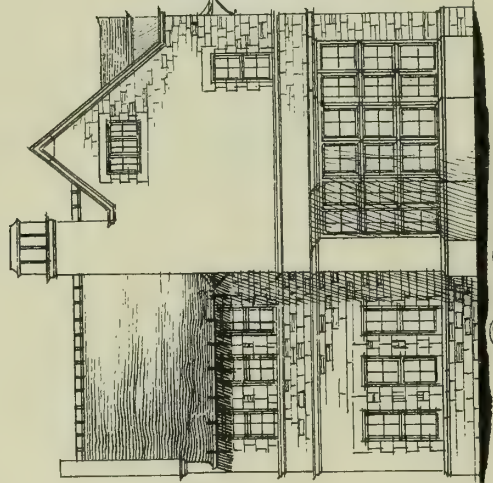

PROVVISOR'S PATENT

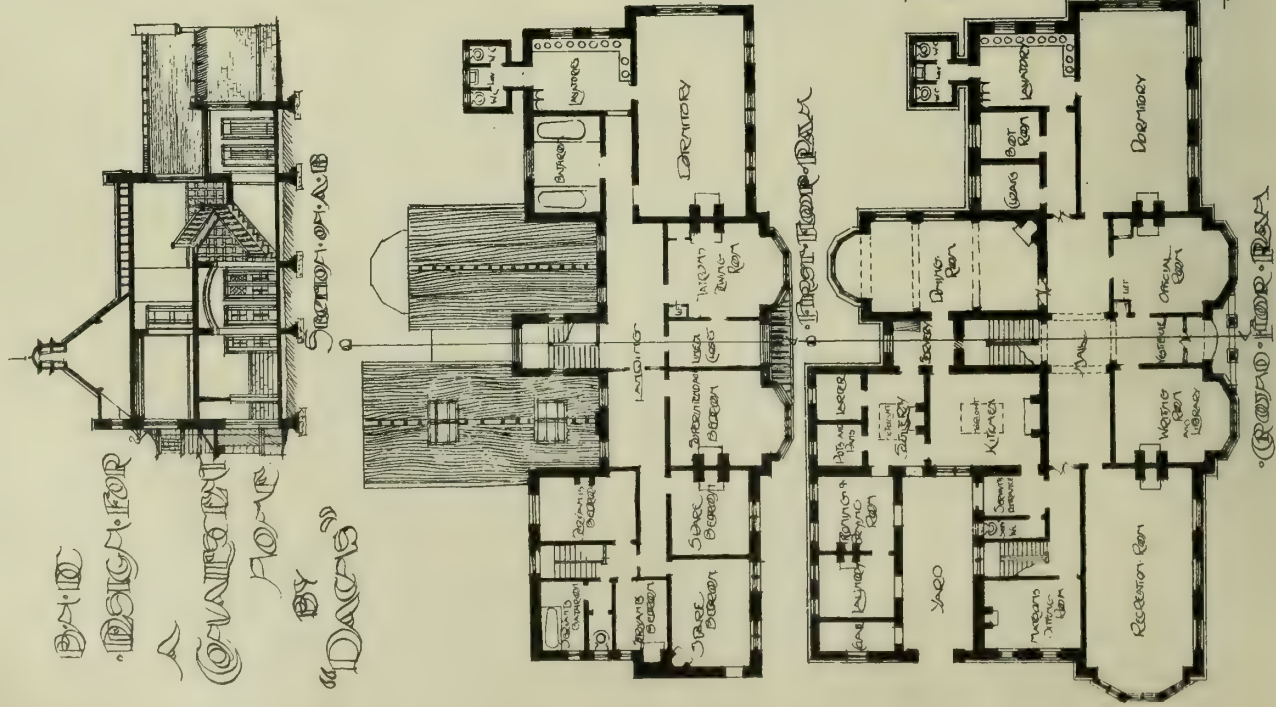

REAR VIEW



B. N. D. C.

PLACED FIRST

Feet  
-30  
0  
5  
10  
Scale for  
S.W.  
Elevation

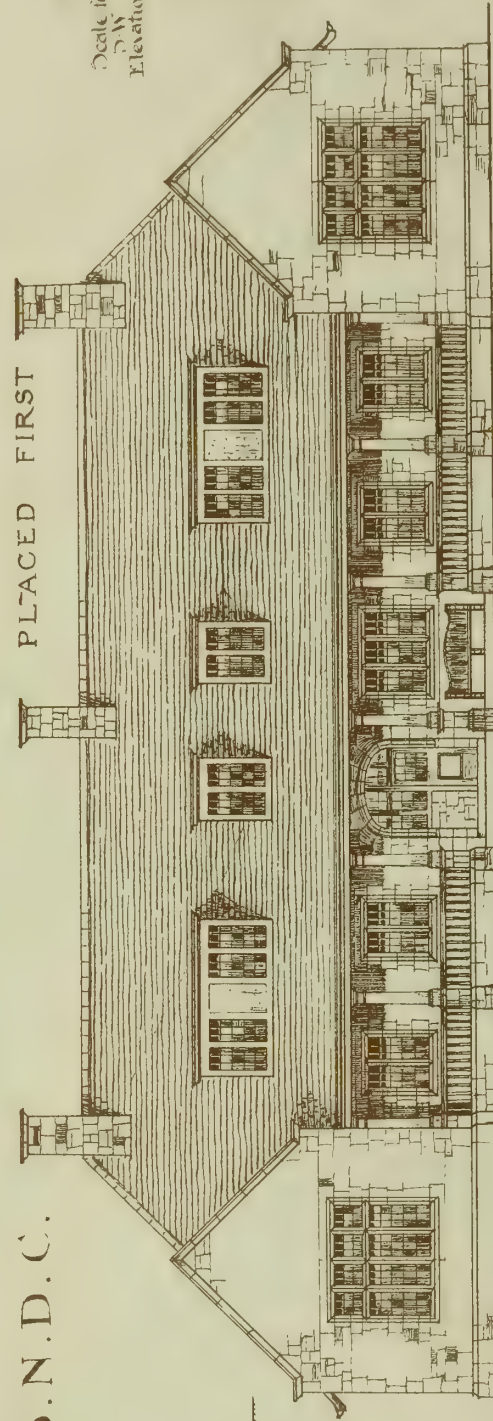

S. W. Elevation.

A CONVALESCENT HOME,  
BY "CENTAUR".



N. E. Elevation.



South View

March/98.

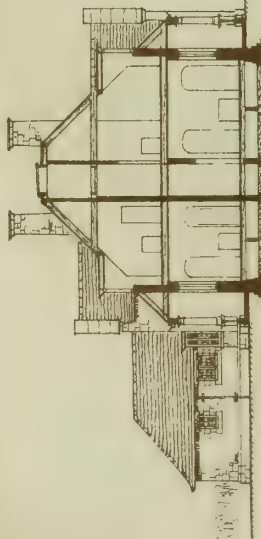

Section at A-A

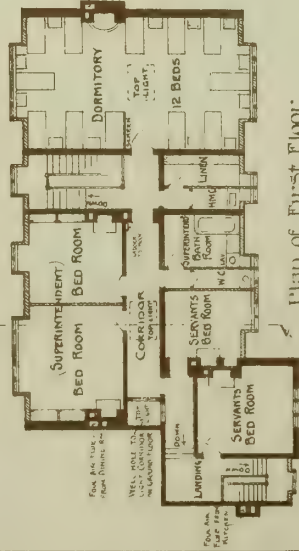

Plan of First Floor.



Plan of Ground Floor.

Scale for Plans etc. 1" = 60 Feet.

Photo-graphed by permission of the Architectural Record Co. from the original drawing by James C. Spence, N.Y.

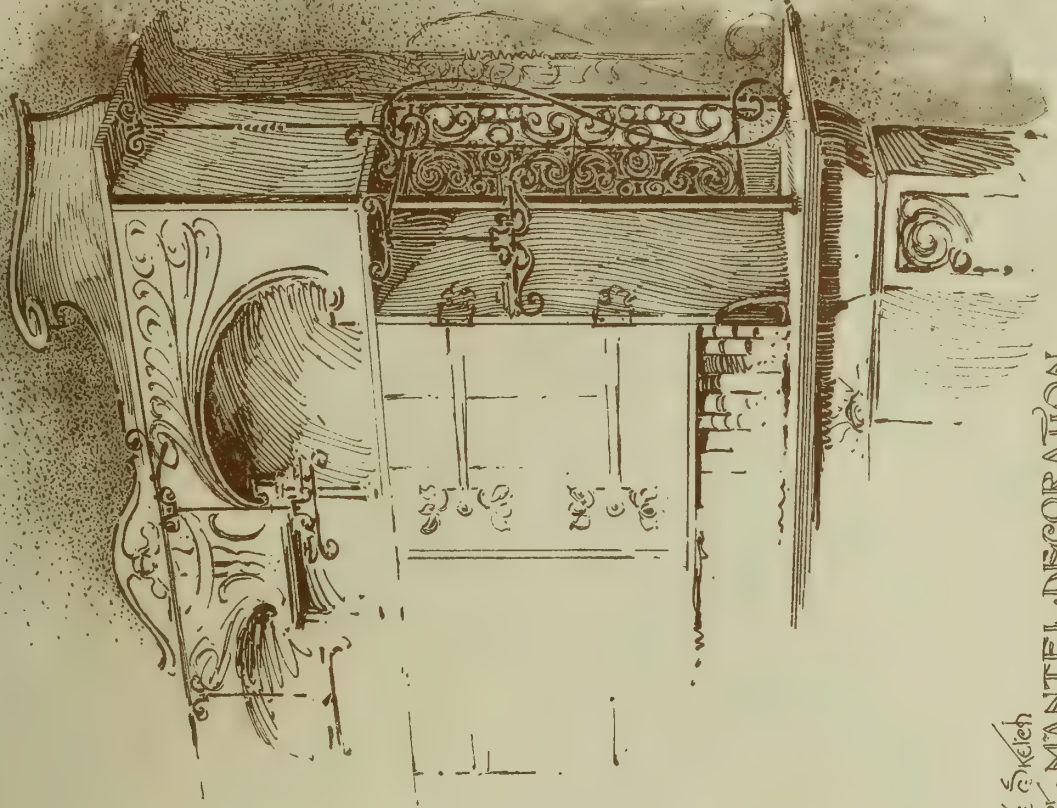
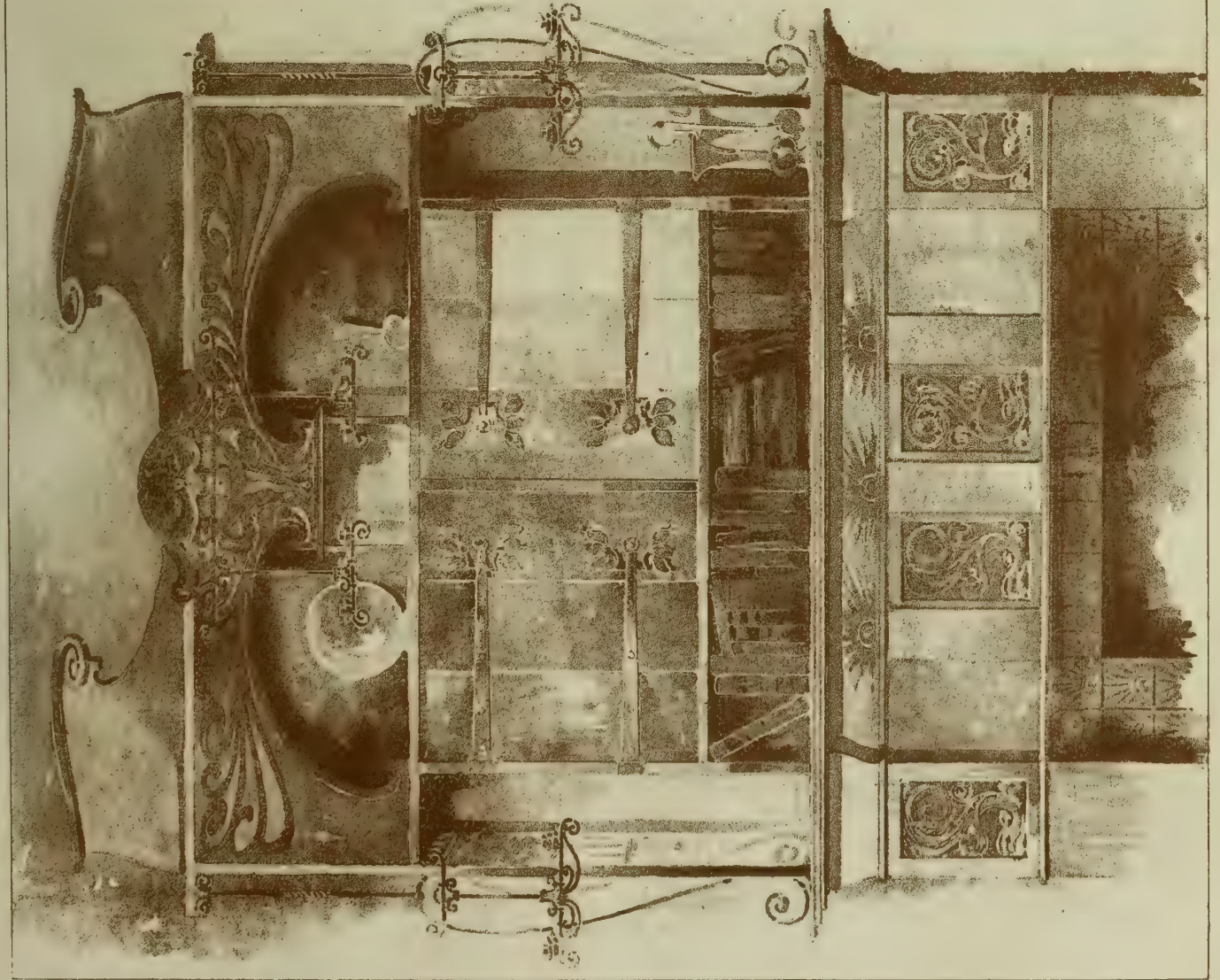

*Perspective Sketch*  
 for MANTEL DECORATION

in OAK.  
 with GESSO ORNAMENT  
 & WROUGHT IRON  
 FITTINGS

• THE GESSO STAINED AND GILDED •

NATIONAL GOLD MEDAL AWARDED GEO MONTAGUE ELLWOOD

PHOTO-FINISHED by James Akerman, Queen's Quay, London, W.C.



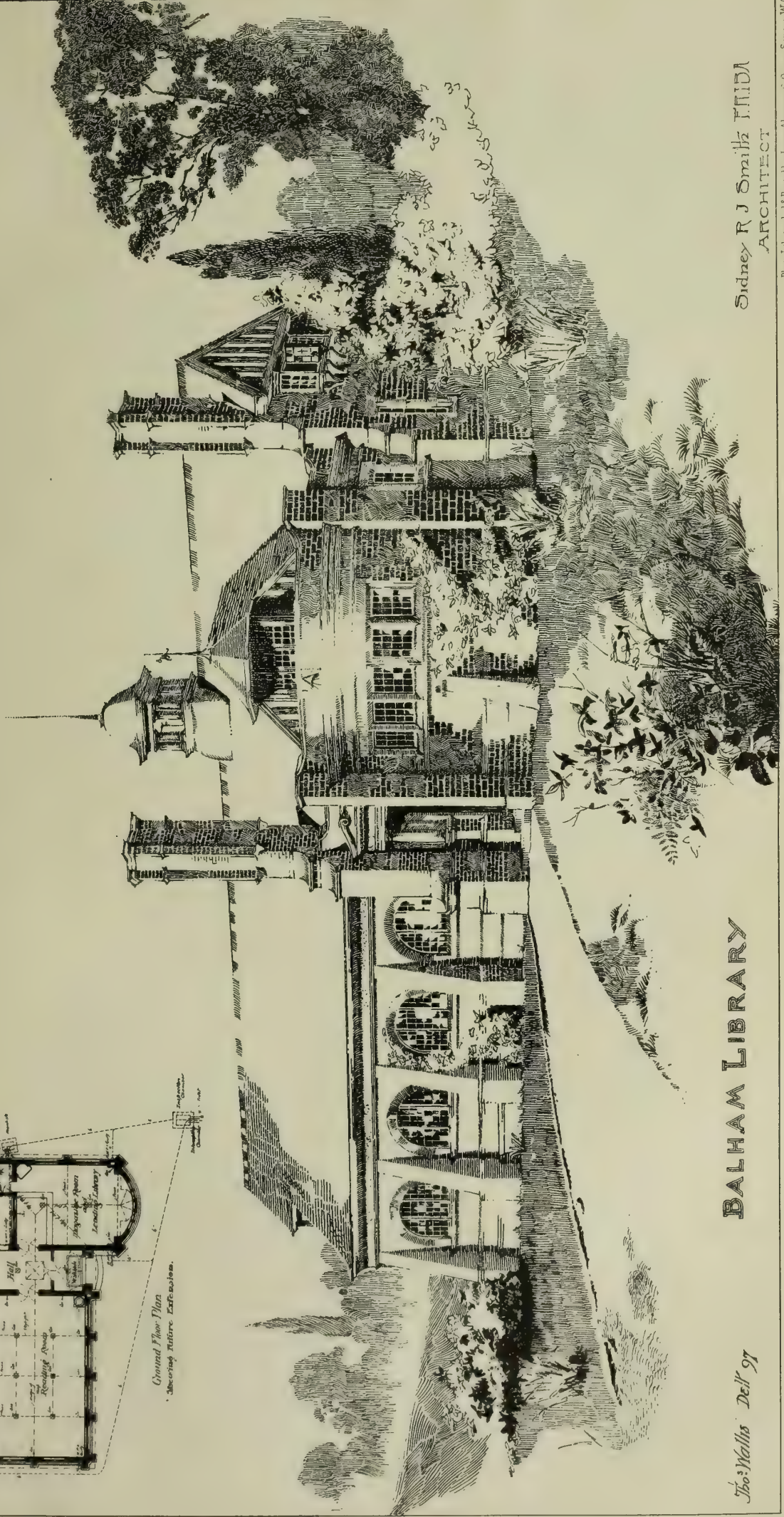
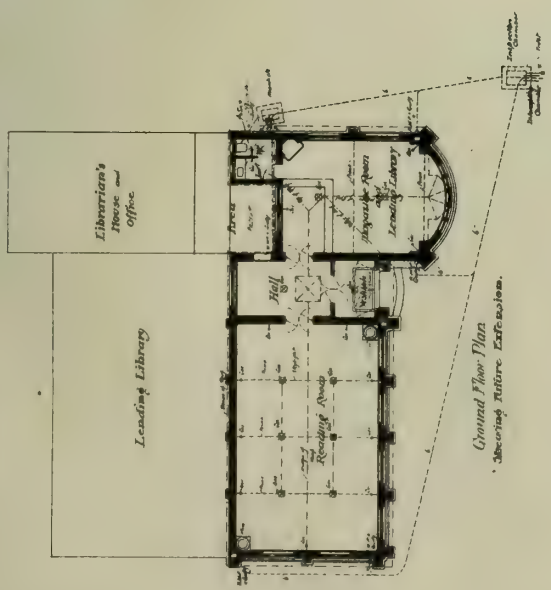

# BALHAM LIBRARY

*J. W. Wallis* Dell 97

Sidney R J Smith & T. P. D. A.  
ARCHITECT

Photo Engraving & Printed by James Albanus, 6 Queen Square, W.C.





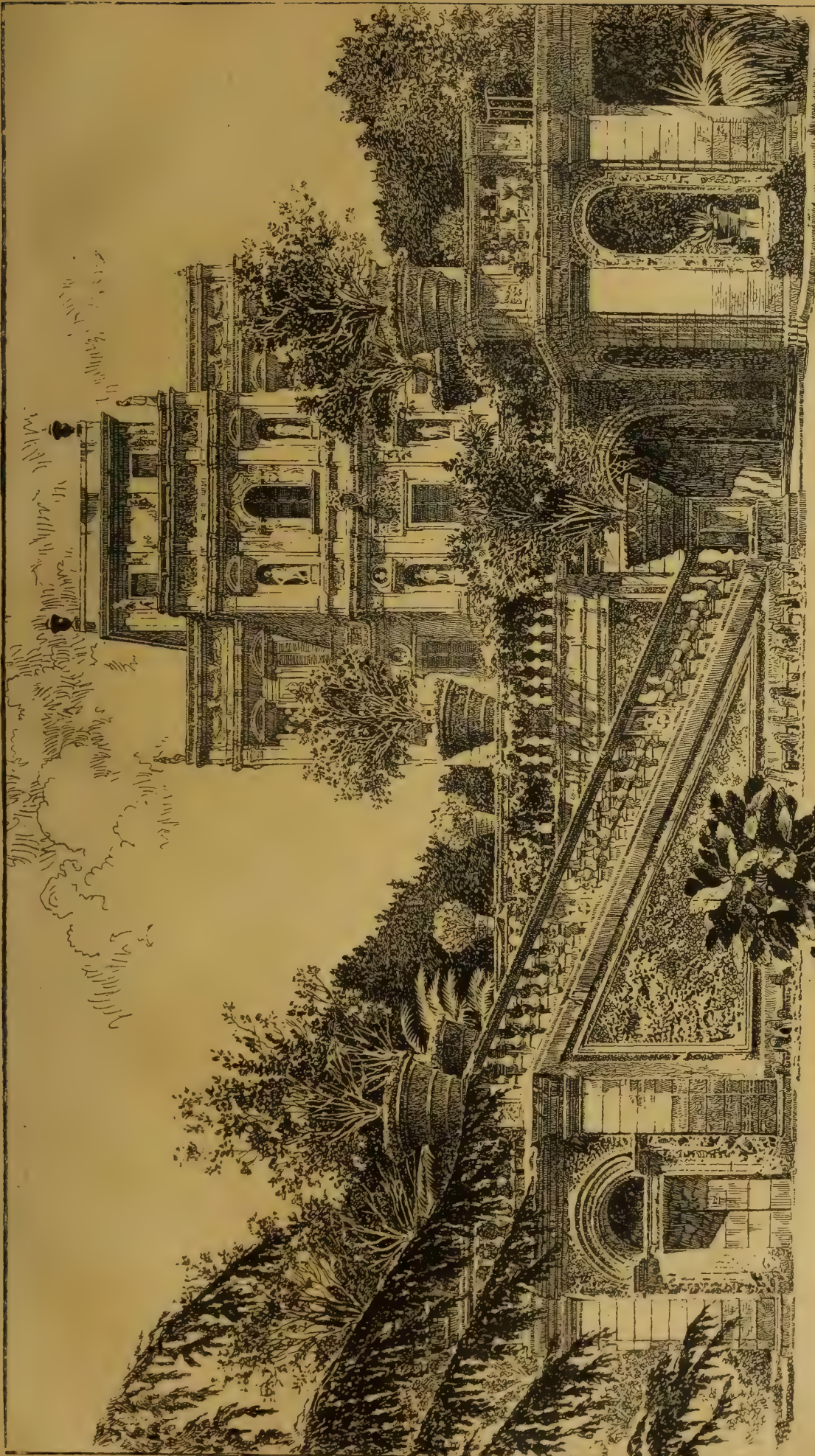

The Casino at Villa Pamphili-Doria, Rome, is a fine example of the architecture of the sixteenth century. It was designed by Bramante and built by the Duke of Pamphili. The building is a two-story structure with a central balcony and a large fountain in the foreground. The gardens are very beautiful and contain many rare plants. The Casino is one of the most important buildings in Rome.

The Casino at Villa Pamphili-Doria, Rome, is a fine example of the architecture of the sixteenth century. It was designed by Bramante and built by the Duke of Pamphili. The building is a two-story structure with a central balcony and a large fountain in the foreground. The gardens are very beautiful and contain many rare plants. The Casino is one of the most important buildings in Rome.

The Casino at Villa Pamphili-Doria, Rome, is a fine example of the architecture of the sixteenth century. It was designed by Bramante and built by the Duke of Pamphili. The building is a two-story structure with a central balcony and a large fountain in the foreground. The gardens are very beautiful and contain many rare plants. The Casino is one of the most important buildings in Rome.

THE CASINO, VILLA PAMPHILI-DORIA, ROME.

## Engineering Notes.

**ABERLADY AND GULLANE RAILWAY.**—Colonel Addison, of the Board of Trade, has made an inspection of the new Aberlady and Gullane Railway, which has been opened for passenger traffic. The engineers of the line are Messrs. Blyth and Westland, C.E., and Mr. Bell is chief engineer; Mr. John Howard, London, is the contractor. The new railway, which is about five miles in length, branches off from the main line of the North British Railway about a mile and a half east of Longniddry Junction. The line is of a winding nature, and the central portion for 3½ miles is fairly level. The station-houses both at Aberlady and Gullane each have a passenger platform 140 yards long, while siding accommodation has also been provided for goods traffic. The heaviest works in connection with the railway were at Gullane Station, which has been excavated in hard boulder clay. The bridges are all faced with coarse freestone ashlar, mostly brought from Fife, and the superstructures are of steel girders.

**GREAT CENTRAL RAILWAY.**—It is anticipated that the new trunk line of the Great Central Railway, forming an extension of the Manchester, Sheffield, and Lincolnshire system from Annesley to London, will be ready to be utilised for the conveyance of coal to the Metropolis by August next. Though the directors have already obtained, for the purposes of a coal-yard at the London terminus, some 20 acres of ground, a Bill is before Parliament in the present session by which is sought authority to acquire the property requisite in order to enable them to double the area of this depot. The red brick and terracotta buildings which will form the terminal station at Marylebone have reached the first-floor level throughout, and in parts have been carried up to the second floor. The subway, which will form one of the means of communication between the station and the large hotel that is being built for the Gordons Hotel Company on an adjacent site, has been completed; but a covered way, which will pass overhead across the street which separates the two blocks of buildings, has yet to be constructed. The erection of a warehouse, having five floors and a total floor-space of about 11½ acres, in proximity to the passenger-station, is a section of the work of which a considerable part still remains to be done; but already the hydraulic cranes and lifts which will form a portion of its equipment have been delivered, and a sufficient area of the buildings required for the reception of goods traffic will be ready for use by the beginning of October. The goods traffic offices, which will form a large block of buildings lying back at some little distance from the main front of the terminal station and facing upon a side street, are being erected, and among other buildings that it has been decided to add at Marylebone are a carriage-shop and a large shop to serve as the place of manufacture of oil-gas to be utilised for the illumination of the railway carriages. Another carriage-shop and a waggon-shop will be added to the company's premises at Neasden, where a shunting-yard and a large engine-shed are to be provided. All the "cut-and-cover" portion of constructing the Metropolitan section of the railway, including that section in which the line passes beneath Lord's Cricket Ground, and all the tunnelling, have been completed, and the rails have been laid from St. John's Wood-road to Finchley-road, a distance of considerably over a mile. From this latter point on in a north-westerly direction, for a distance of about 40 miles, the Great Central Company's trains will pass over the Metropolitan Company's system, which, for the length between Finchley-road and Harrow, is having its number of lines increased.

**WADEBRIDGE AND PADSTOW RAILWAY.**—Rapid progress is being made with the construction of this railway. The station-house and platform at Padstow are almost completed. The station-house has been literally built in a pit, the top of it only reaching to the surrounding surface, and some hundreds of square yards of rubble and rock must be removed before the line can be opened. This rubble and rock will be thrown into the old shipwright docks, which, when filled up, will provide space for the purpose of a railway wharf. After crossing Dennis Cove on an embankment the line penetrates Dennis Hill—a cutting about 35 yards long, varying in height from 10ft. to 50ft. At the end of this cutting is the bridge or

viaduct across the Sea Mills River, a distance of 100 yards; two-thirds of this space consists of an embankment, which has already been formed. In the remaining space is now being constructed an iron viaduct, carried on iron tubes driven into the mud. The bridge will only leave sufficient head room for the barges to pass under. The line when made will be nearly level, and will be only a few feet above high-water mark. The cutting at Ball Hill represents the heaviest portion of the work yet to be done. This cutting, which is to be an open one, will not be less than 70ft. deep, and necessarily very broad.

## CHIPS.

At Harborne Parish Church, the old seats occupied by the choir have just been replaced by oak carved stalls. They were occupied on Sunday for the first time. They have been erected from designs from Mr. R. Heaton, of Corporation-street, Birmingham, and the work has been executed by Mr. H. H. Martyn, carver, of Cheltenham. A clergy stall was also utilised on Sunday.

The well-known engineer Privy Councillor Bausch, who was charged by the Imperial Ministry of the Interior of the German Government with the cutting of the Emperor William Canal, died on Friday.

The old Wesleyan Chapel at Guisely has, through the enterprise of a local firm of contractors (Messrs. S. Mounsey and Son), been converted into public baths. Besides a number of slipper, vapour, and other baths, there is a large swimming-bath, measuring 49ft. long by 19ft. wide, and varying in depth from 4ft. to 6ft. The bottom is of white tiles, and the sides of white glazed bricks. The dressing-boxes, fifteen in number, have open fronts, this method having been adopted to prevent thefts from the clothes of the swimmers. The formal opening took place on Saturday.

On Thursday in last week, Colonel A. G. Durnford, R.E., one of the Local Government Board's inspectors, held a public inquiry at Wrexham, respecting the application of the town council for sanction to borrow the sum of £50,750 for purchasing the Wrexham Market Hall Company's property and undertaking, and the sum of £340 to purchase the Beast Market, to be left as an open space for ever.

Before quitting office as High Sheriff of Devon, Mr. Robert Harvey, of Palace Gate and Dunderidge, Totnes, has placed two memorial windows in the north aisle of Truro Cathedral. The subjects are St. Alban, St. Pancras, St. Perpetua, St. Lawrence, St. Catherine, and St. Cyprian. Mr. Harvey has also added a thanksgiving window, an illuminated clock and chimes, and restored the churchyard cross in his own parish of Harberton.

An organ and screen were dedicated at the Church of St. John, Knotty Ash, Lanes, on Monday. The work has been carried out from the designs of Mr. Charles E. Deacon, architect, of Liverpool. The organ, which is fitted with pneumatic action, is inclosed in a carved oak case, designed in harmony with its surroundings, and being supported upon a carved canopy, springing from the screen, beneath which runs the whole length of the choir stalls. The organ has been made by Messrs. Conacher and Co., of Huddersfield; whilst all the oakwork is from the studios of Messrs. Harry Hems and Sons, of Exeter.

The Boards of Guardians of Manchester and Chorlton, acting together under the authority of the Local Government Board, have purchased an estate in the neighbourhood of Chorley with the object of erecting cottage homes for the treatment of imbeciles and epileptics. The site is under the shadow of Rivington Pike, and has cost a sum of £19,000. The Boards jointly aim at accommodating 1,000 patients.

A new Episcopalian Church of St. Peter is in course of erection at Torry, N.B., from plans by Messrs. Kinross and Tarbolton, of Edinburgh, at a cost of £5,000. The building consists of a narrow and lofty nave, with north and south aisles. The roof will have a span of 35ft., and will rise 60ft. above the floor. The walling is of pink granite, and when completed the church will seat 600 persons.

The foundation-stone of an intermediate school was laid at Penygroes on Monday. The contract has been let to Mr. Richard Jones, Llanwrda, the architect being Mr. Evan Evans, C.E., the county surveyor of Carnarvonshire. The total cost of the work will be £2,763.

A Jubilee memorial clock has been placed in the tower of East Farleigh parish church, Kent. The clock, which was manufactured by Messrs. J. Smith and Sons, of Derby, makers of the clock in St. Paul's Cathedral, chimes the Cambridge quarter on the 1st, 2nd, 3rd, and 6th bells, striking the hours on the tenor. It has one dial, 5ft. 6in. in diameter, facing the south.

## Building Intelligence.

**BURY, LANCS.**—The new Park Congregational chapel was opened on Good Friday. It is Jacobean in style, and measures 77ft. by 39ft. A vestry for the minister is placed at the south-east angle of the building, and the gallery is over the vestibule at the west end. The chapel contains seating accommodation for 450 persons. The benches and the interior woodwork are in pitch-pine. The building is faced with Yorkshire parpoinets. The chapel has been erected from the designs of Mr. J. D. Mould, architect, of Silver-street, Bury. The main contract was placed with Messrs. T. and J. Foster, of Ramsbottom.

**OLD KILPATRICK, N.B.**—After being closed for over three months, the Old Kilpatrick Parish Church was reopened on Sunday. The reason for the closing was the alteration and improvement of the building, consequent on a number of gifts having been presented in commemoration of the Queen's Diamond Jubilee. These include a three-manual pipe organ and an apse in which to house it, and a new pulpit, hexagonal in form, built of blue Ayrshire stone, with a top of oak, Gothic arched in each side. A peal of eight bells, cast by Gillett and Johnston, of Croxford, has also been presented. They weigh three tons without machinery. An oak carved Communion table and a baptismal font, made of blue Ayrshire stone, matching the pulpit, are other gifts. The church has been painted, and new heating apparatus put in. A four-light window of stained glass representing the Ascension has been placed in the centre of the apse, while at the sides two other windows representing the Four Evangelists have also been given.

**STRATFORD-ON-AVON.**—Lloyds' Bank (Limited) are about to erect new bank buildings upon the site of their present premises at the corner of Bridge-street and Union-street, Stratford-on-Avon. The old buildings are now in course of demolition. The plans of the new bank, which have been prepared by Mr. J. A. Chatwin, of Temple-street, Birmingham, show a much larger structure. The building will provide a banking-room next Bridge-street, with consulting and waiting rooms, strong rooms, and residence for the manager. The elevations in Bridge-street and Union-street will be of Bath stone, and the principal entrance will be at the corner of the streets named, with oriel window projecting over, and surmounted by a short spire, which will form a feature as seen from High-street. The extent of frontage to Bridge-street will be 42ft., and that to Union-street 52ft. (including manager's house), and the height to ridge will be 51ft. with a slightly lower elevation to Union-street. The corner entrance will be recessed, and the oriel window over—a feature of the building—is carried by groins springing out of the keystone of the doorway. There are carved panels between the corner windows. The lower range of windows in Bridge-street will have pilasters and columns between; the middle range contain mullions and transoms, while the top range will be of a more ornate character. There will be six large windows on the ground floor of the banking-room, which will be 38ft. by 20ft. All the bank fittings will be of mahogany, and the building will be lighted and ventilated by an inner court, extending the full height of the building, cased with white brick. The style adopted is Renaissance. A low ornamental palisading will protect the stonework from being scored or scratched. The builders are Messrs. Collins and Godfrey, of Tewkesbury.

The corporation of Scarborough have adopted a recommendation of the committee that they should purchase for £33,000 the mansion and grounds of Mr. J. W. Woodall in St. Nicholas-street. The house is to be converted into public offices, and the grounds on the undercliff facing the sea are to be used as a public park.

On May 4, the anniversary of the terrible bazaar catastrophe in the Rue Jean Goujon, Cardinal Richard will lay the foundation-stone of a chapel to commemorate that fatal disaster. M. Guilbert, the architect, has adopted the semi-classical style associated in France with the name of Louis XVI. His building, almost square outside, is to be raised some 10ft. above the level of the street. Within, the chapel will have a circular form, eight marble pillars supporting the central dome. Beside the building a small space is to be laid out as a garden and surrounded by an arcade with the stations of the Cross.

## COMPETITIONS.

**BIRMINGHAM: HOLLYMOOR ASYLUM.**—The competitive plans for the erection of a new lunatic asylum on the Hollymoor estate, near Rubery, are now open to inspection. It may be remembered that the need for increased accommodation for lunatics having become urgent, the Asylums Committee proposed to entrust the preparation of plans to Messrs. Martin and Chamberlain, who designed the present establishment at Rubery. The majority of the city council, however, rejected the recommendation, and decided that a limited competition should take place by six Birmingham firms, to each of whom £100 should be given for the preparation of plans. As we stated last week, on the report of the assessor, Mr. G. T. Hine, the committee have selected the designs marked "Forward," which proved to be the motto adopted by the firm to whom they originally recommended that the commission should be given. The other five competing firms were Messrs. Cossins and Peacock, Messrs. Mansell, Mr. F. B. Osborn, Messrs. Ingall, and Messrs. Cross and Nicholls. The asylum is to accommodate 800 patients and the necessary staff. Access to the site is by Bedlam-lane, which skirts it upon the north-west, and the selected plans and several others place the main entrance and the medical superintendent's house at the nearest corner to the road. The selected plans and several others show, says the *Birmingham Post*, a system of corridors, of which the one on the north side runs from east to west, while another makes a semicircular sweep to the south. Within the inclosure formed by these corridors are arranged the large dining and recreation hall, with the kitchens and other kindred departments, while the wards or pavilions are upon the exterior of the circuit. Messrs. Martin and Chamberlain place their reception wards and infirmary wards entirely upon the ground floor. The pavilions are in two stories, and the upper stories of the infirmary blocks are used as dormitories for chronic patients. As a rule, a pavilion and two wings of separate apartments inclose a quadrangle to be used as an airing-court, and the ground-floor arrangement enables the weaker infirmary patients and their attendants to reach the airing-courts with the least possible fatigue. The pavilions are mostly arranged in an east and west direction, so that the windows may enjoy a southern aspect, and that the patients may enjoy the utmost benefit derivable from light and air. The elevations show a somewhat severe brick structure with mouldings beneath the eaves, and window bays to break the otherwise flat monotony of the walls. A water-tower is provided for, which will carry a tank of 40,000 gal., a little more than a day's supply. Messrs. Martin and Chamberlain submit an alternative ground plan, in which the arrangement of blocks and corridors is somewhat different, and less widely distributed. The buildings have been arranged to follow, as far as practicable, the fall of the ground, the variations of level giving a gentle rise and fall in the corridors, by which the occurrence of odd steps is avoided. In the plans marked "Control," the blocks of building are more symmetrically and more compactly arranged. The entrance is centrally placed on the north side, and has a Renaissance elevation. An east and west corridor, and a semicircular one reaching to the southern limits of the group of buildings, are also features of the plan. The architects are Messrs. Cossins and Peacock. Mr. Osborn's plan (marked with a cross) shows the general arrangement of buildings placed aslant, so as to be roughly parallel to Bedlam-lane, and giving south-east and north-west aspects to the principal blocks. The corridors are placed at angles to one another. The entrance is from a private drive to the south, and a clock-tower occurs as a decorative feature of the architecture. Messrs. Mansell and Ingall both adopt a rectangular arrangement of buildings, and the former show an Elizabethan design for the entrance; while Messrs. Cross and Nicholls dispose their buildings in relation to a straight corridor on the north and a semicircular one on the south.

**DERBY.**—In November last the committee of Holy Trinity parish church, Derby, presided over by the Rev. H. Martin, B.A., vicar, had the consideration of rebuilding before them, and in consequence of a request by Messrs. Naylor and Sale, architects, of Derby, to be allowed to submit sketches for a new church (which was in contemplation), it was resolved that this firm should send in sketches in competition with Mr. Charles E. Hewitt, architect, of Brighton, who had been

acting as professional adviser to the church committee for about four years. Certain conditions of this competition were given. A sub-committee was formed to report on the merits of the submitted designs, which were three in number, Messrs. Naylor and Sale submitting two designs, and on March 14th the sub-committee met to inspect the designs and to recommend the design which they considered best. The committee unanimously decided in favour of the design submitted by Mr. C. E. Hewitt, and this recommendation was confirmed by the church committee last Tuesday, April the 5th, when his appointment as architect was made. The proposed new church is to occupy the same site as the existing church, and is designed to accommodate 800. It is to be constructed of red brick, with stone dressings, in the Early English style of Gothic architecture. There will be a nave, with clerestory, aisles, transepts, and chancel, with a west-end tower, to be surmounted (eventually) with a stone spire, the apex of which will rise about 132ft. from the ground. The organ and choir will be accommodated in a western organ gallery. The estimated cost of the new church is £6,000, exclusive of the spire.

**DUKINFIELD.**—The urban district council, having decided to erect a town hall at a cost of £10,000, advertised for competitive plans, offering prizes of £40 and £20. In response, 22 sets of plans were received. The prizes have now been awarded as follows: First premium, John Eaton, Sons, and Cantrell, Ashton-under-Lyne; second, Hindley and Marshall, Monton, Eccles. The new town hall is one of the Diamond Jubilee commemoration schemes.

**HARROGATE TECHNICAL SCHOOL.**—Mr. Morley, architect, of Harrogate and Bradford, who secured the first premium in connection with the competitive designs for a new technical school at Harrogate, has been appointed architect for the new building. Mr. Morley has been instructed to get out specifications for his plans, and amended plans, and report to a future meeting. A site for the school has been secured at the corner of East-parade and Bower-road.

**SURBITON.**—The designs of Messrs. Carter and Ashworth, of 55, Clarence-street, Kingston-on-Thames, and 8, Duke-street, Adelphi, W.C., have been placed first in a limited competition for a new club-house in St. James's-road, Surbiton, for the Surbiton Club. The building, which is to cost £2,750, will be proceeded with at once.

## CHIPS.

Mr. Herbert H. Law, L.G.B. inspector, has held an inquiry at Bognor into an application of the urban district council to borrow £2,000 for the construction of a new sea-wall and esplanade at the west end, near the Black Mill.

The Clippens Oil Company are reopening the Straton Quarries, which were carried on for forty years previous to 1885. The material is freestone, the greater part of Newington, Edinburgh, and the whole of the Loanhead district having been built with it. The reopening will afford employment to a number of men, and will help to lessen the distress caused by the stoppage of the oilworks.

A committee of the town council of Glasgow recommends the purchase of A. K. Brown's "Spring" landscape, and an "Interior" by Tom M'Ewan. The pictures are now in the exhibition of the Royal Glasgow Institute.

The City Council of Birmingham have raised the salary of Mr. John Price, city surveyor, who had resigned the office of deputy engineer to the Birmingham Tame and Rea District Drainage Board, to £1,000 per annum.

Mr. Protherd, of Cheltenham, has reported to the churchwardens of Wrexham on the condition of the fine Perpendicular parish church, and states that a displacement of the masonry of the south porch is in progress, while the whole of the fabric will have to be attended to before long. One of the pinnacles of the noble west tower is being repaired.

On Thursday in last week Mr. H. T. Tulloch, one of the Inspectors of the Local Government Board, held an inquiry at Bournemouth into the application of the town council to borrow £8,000 for sewerage, £500 for the continuation of Braidley-road, £1,050 for public walks and pleasure grounds improvements, £980 for private street improvements, £2,500 for lighting the pier and lower Pleasure Gardens with electricity, £260 for work on the Dean Park Horse Shoe site, and for power to borrow £1,730 for the purposes of the Bournemouth Corporation Act, 1897. Evidence was given by Mr. Lacey, the borough surveyor.

## PROFESSIONAL AND TRADE SOCIETIES.

**EDINBURGH ARCHITECTURAL ASSOCIATION.**—At the last meeting of this association, Mr. Thomas Ross, the president, in the chair, Bailie Pollard, convener of the Town Council's Public Health Committee, gave an address on "Fever Hospital Structure, with special reference to the new City Hospital at Colinton Mains." Having given a brief sketch of the history of the development of isolation hospitals, the lecturer said that down to the early sixties, and even later, the treatment of fevers in our large cities was without skill, proper nursing, or adequate appliances. Mainly through the instrumentality of the late Mr. Ernest Hart, a great reform was effected five-and-twenty years ago, when efficient fever hospitals began to be erected under the charge of the Metropolitan Asylums Board. In France and Germany greater progress had been made. It was only in recent years that local authorities throughout Great Britain had been aroused by public opinion and legislation, so that infectious hospitals were now becoming general all over the country. The prime consideration for the architect of a fever hospital must be to make his structure an instrument of healing. External appearance was not to be despised; but the internal arrangements must receive closest study and most minute care. With reference to situation, well regulated fever hospitals might exist even in populous centres, without detriment to the community. When the choice of a site was in view, many reasons showed that the hospital was best at a distance from other dwellings, not so much from fear of spreading disease as for the sake of the institution itself. Differing from Sir Thorne Thorne, of the Local Government Board, who suggested hospital provision for one per 1,000 of the inhabitants, the lecturer advocated larger hospital accommodation, and, upon experience of Edinburgh, was prepared to maintain that provision should be made for one in every 600. The materials of the structure might be pasteboard, canvas, wood, brick, or stone. Stone was preferred in Scotland. The laying out and arrangement of buildings was dwelt upon, and it was shown how needful it was that the different diseases should be classified, and cross-infection guarded against; while the different parts of the whole structure should be so placed as to secure greatest convenience of access between the sick-rooms and the administrative, culinary, and other departments. Drainage, ventilation, and heating were then described as elements of essential importance, the requisite amount of floor-space and air-space per bed being also alluded to. The laying-out of wards and of ward accessories, baths, and lavatories was next discussed. Dwellings for the doctors, nurses, ward attendants, and servants were described, and the most suitable arrangements for kitchen, laundry, and other services were dealt with. After setting forth the main objects to be sought in a completely efficient modern hospital, Bailie Pollard proceeded to show how these were likely to be obtained in the new city hospital at Colinton Mains. He exhibited by the limelight a series of views from the plans prepared by Mr. Robert Morham, city architect. Speaking from considerable acquaintance with fever hospitals on the Continent and at home, the lecturer felt warranted in saying that by means of Mr. Morham's plans the Edinburgh Hospital would at its opening be behind no fever hospital in the world in respect of efficiency. He directed special attention to the situation of the hospital, with its southern exposure and uninterrupted sunlight. Particular mention was also made of the large provision of sun-rooms for patients during convalescence.

Contracts have been entered into by the British Electric Traction Company for the conversion of the tramway line running from Hart's Hill to Stourbridge into an electric system, and it is expected that the work will be done during the next six months. Other improvements and extensions are also contemplated.

The foundation-stone of the new church and convent of the Immaculate Conception of St. Francis, at Bocking Bridge, has been laid. The architect is Mr. J. F. Bentley. Messrs. A. Brown and Son are the builders, and Mr. W. L. Tett is clerk of the works. The buildings comprise a church with sanctuary chapel and transept, and the cells, corridor, refectory, and kitchen of a religious house. The church, which is to be of red brick with stone dressings, is in the Early Decorated style.

## TO CORRESPONDENTS.

[We do not hold ourselves responsible for the opinions of our correspondents. All communications should be drawn up as briefly as possible, as there are many claimants upon the space allotted to correspondents.]

It is particularly requested that all drawings and all communications respecting illustrations or literary matter should be addressed to the EDITOR of the BUILDING NEWS, 332, Strand, W.C., and not to members of the staff by name. Delay is not unfrequently otherwise caused. All drawings and other communications are sent at contributors' risks, and the Editor will not undertake to pay for, or be liable for, unsought contributions.

Cheques and Post-office Orders to be made payable to THE STRAND NEWSPAPER COMPANY, LIMITED.

## TERMS OF SUBSCRIPTION.

One Pound per annum (post free) to any part of the United Kingdom; for Canada, Nova Scotia, and the United States, £1 6s. 0d. (or 60s. 30c. gold). To France or Belgium, £1 6s. 0d. (or 33fr. 30c.). To India, £1 6s. 0d. To any of the Australian Colonies or New Zealand, to the Cape, the West Indies, or Natal, £1 6s. 0d.

## ADVERTISEMENT CHARGES.

The charge for Competition and Contract Advertisements, Public Companies, and all official advertisements is 1s. per line of eight words, the first line counting as two, the minimum charge being 5s. for four lines.

The charge for Auctions, Land Sales, and Miscellaneous and Trade Advertisements (except Situation advertisements) is 6d. per line of eight words (the first line counting as two), the minimum charge being 4s. 6d. for 40 words. Special terms for series of more than six insertions can be ascertained on application to the Publisher.

Front-page Advertisements 2s. per line, and Paragraph Advertisements 1s. per line. No Front-page or Paragraph Advertisement inserted for less than 7s.

Advertisements for the current week must reach the office not later than 3 p.m. on Thursday. Front-page Advertisements and alterations in serial advertisements must reach the office by Tuesday morning to secure insertion.

## SITUATIONS.

The charge for advertisements for "Situations Vacant" or "Situations Wanted" is ONE SHILLING for TWENTY-FIVE WORDS, and SIXPENCE for every eight words after. All Situation Advertisements must be prepaid.

## NOTICE.

Bound copies of Vol. LXXXIII. are now ready, and should be ordered early (price Twelve Shillings each), as only a limited number are done up. A few bound volumes of Vols. XXXIX., XL., XLI., XLVI., XLIX., LI., LIII., LVIII., LIX., LXI., LXII., LXIII., LXIV., LXV., LXVI., LXVII., LXVIII., LXIX., LXX., LXXI., LXXII. may still be had, price Twelve Shillings; all the other bound volumes are out of print. Most of the back numbers of former volumes are, however, to be had singly. Subscribers requiring any back numbers to complete volume just ended should order at once, as many of them soon run out of print.

RECEIVED.—J. and H. O.—D. N. P.—W. C. A. Co.—R. F. A.—A. B. and Sons (Bristol).

## "BUILDING NEWS" DESIGNING CLUB.

DRAWINGS RECEIVED.—"Luna," "McGilligan," "Gib," "Derige," "Don't Know," "Rita," "Centaur," "B. C. P.," "Swan," "Microbe," "Hotspur," "Zeo," "Petticoats," "Pantile," "Caedmon," "Umbopa."

## Correspondence.

## SYBILS—NOT ANGELS.

To the Editor of the BUILDING NEWS.

SIR,—In your issue of March 18, 1898, there occurs a mistake of the most serious order. The large reproduction you have of Michel Angelo's Sybils is labelled "Figures of Angels." I am greatly surprised that in your article the well-known sybils are also referred to as "angels." Being sybils, they were naturally wingless, so that your contention about these angels being wingless is most amusing. I trust that for the benefit of your many readers you will correct this error in the next number of your esteemed periodical. Such mistakes as this should not be allowed to occur. When they do occur the misinformation which they convey should be promptly rectified.—I am, &c.

A. A. HOPKINS.  
361, Broadway, N.Y. City.

## KIRKHAM WORKHOUSE COMPETITION.

SIR,—Having competed for the above together with Mr. Fred. E. Dotchin, of Newcastle-on-Tyne, it is with much regret I observe the letter from Messrs. Crickmay and Son (the first premiated) in your issue of the 8th inst.

It is becoming positively disgraceful the way in which the majority of the architectural competitions are apparently conducted, and the final decisions arrived at—even as in this case, when

the award of an assessor is given, this is not eventually adhered to.

It is only within the last few months that I competed successfully for a large Poor-law establishment for the Gateshead-on-Tyne Guardians. I was appointed to carry out the work, and prepared all the contract drawings, specifications, quantities, deposited plans with the Local Government Board, which were passed and sealed. I also deposited the plans with the local authorities, and tenders were received, and all in order for the due performance of the contract, and now, after months of untiring work and great expense, I am compelled by the guardians, under their conditions of competition, to step aside and relinquish my position, and allow a local architect to be appointed by the guardians in my place, and so carry out the work, and, as I presume, from my drawings, &c., and receive the commission due to me.

It is only an architect that can form an adequate idea of the enormous amount of work I had to do from first to last, and for which I have not received a proper remuneration, neither have any of my expenses been paid. A more heartless decision on the part of a public body it is hard to conceive.

It is under such conditions and expectations as these that the competing architect has now to look forward, as this state of affairs is brought forcibly to one's notice almost every week, and I continually hear from my professional brethren such remarks as, "I don't think I shall compete—it is hard to tell if it be a genuine competition;" "I expect it is all out and dried;" "It will be hard work and good money thrown away, perhaps, if it be not a fair competition."

It passes my comprehension why our Institute does not take up strongly this matter and much dissatisfied question of competitions. It is certainly high time something was done.—I am, &c.,

CECIL A. SHARP.

59, Fenchurch-street, E.C.

## CHIPS.

About 800 men are affected by the dispute in the Scotch furniture trade. It is understood that about 100 men have left the district and obtained employment in England. No steps have yet been taken to reopen negotiations.

In the Manx Legislative Council on Tuesday, Lord Henniker handed over the picture of the Queen which her Majesty has presented to the Government of the island. The picture, which has been signed by her Majesty, was painted by Von Angeli. It is inclosed in a massive frame surmounted by a crown, and is hung in the Council Chamber.

The old mansion at Winchester, known as the Abbey House, is to be altered, added to, and rebuilt, so as to accommodate the Museum, Library and Reading-room, Art Gallery, and Reference Library, and thus free a large area in the Guildhall for municipal business. The council on Thursday empowered a committee to prepare a report and plans.

Considerable progress has recently been made with the museum which is being formed in connection with the School of Hygiene at University College, Liverpool, and it will be formally opened by the Lord Mayor during the first week in May. The work of well-known firms in Liverpool, London, Manchester, Leeds, and Leith is represented, many of the specimens having been presented.

The new organ at New-road Congregational Church, Bury, Lancs, erected by Messrs. Lewis and Company, organ builders, of Brixton, London, was opened yesterday (Thursday). It is built on the tubular pneumatic principle; and the bellows will be blown by a Ross valve engine (hydraulic). The organ contains three manuals and pedals and 32 stops in all. The whole of the metal-work is of spotted metal.

A turret quarter-chime clock has been erected in the tower of the Wesleyan chapel, Long Preston, near Skipton, and two bells, to commemorate the Diamond Jubilee, which was set going on Good Friday. Messrs. W. Potts and Sons, Leeds, are the makers.

A new chapel is to be erected by the New Connexion Society at St. Ives, Cornwall. It is to have a spire of 82ft. high, and the edifice will accommodate 450 people in the main body, and 100 in a gallery placed over the entrance lobby. In addition to this there are to be minister's and choir vestries, with adjoining school buildings, classrooms, lavatory, &c. The estimated outlay is £3,500, and the work is to be completed by May next year. Mr. J. W. Firth, of Oldham, is the architect, and Mr. J. L. Sandry, of St. Ives, the builder.

## Intercommunication.

## QUESTIONS.

[11983.]—**Adjoining Owner.**—Two building sites adjoin. On one a residence has been erected and let to a tenant. The owner of both properties is now desirous of building on the other site, close up to the boundary; but his tenant objects to allow any scaffolding being erected on the first site to enable his landlord to carry up the outside wall of residence to be built on other site which abuts, and has further given notice of objecting to any slung or overhanging scaffolding being used, which is absolutely necessary to carry out the work. Would the owner run any risk should he go on with the work either by erecting scaffolding on the first site, or, supposing he could not do this, would he be running any risk if he used a slung or overhead scaffolding to enable him to carry out his proposed work? Being the owner of both properties, he feels it hard upon him by his having let one that he should be prevented from building his house on the second site, but would risk a lawsuit if he felt he was within his rights in going on with the work.—ROYSTON.

## REPLIES.

[11924.]—**Terracotta Work.**—Several well-known firms, such as J. C. Edwards, of Ruabon, and other firms, supply excellent terracotta. The smaller the blocks, in reason, the better, and they should not exceed 3ft. cube. The larger the block, the more difficult it is to insure straight arrises and true lines. The joint should be rather fine, but not too close, or the terracotta is apt to flush. For filling the blocks, Roman is less likely to burst the block than Portland cement; lime concrete is often used with good results.—G. H. G.

[11929.]—**Useful Items.**—I know no way of using bees-wax in the manner asked; but "N." can dissolve paraffin-wax in benzine, placing the wax in the benzine in a cup, and the latter in a larger cup or basin of boiling water. You can then apply the melted wax or benzine as a capital waterproofing solution to cloth or canvas. Applied to the inside of an umbrella, it will make it out-last three.—JABEZ.

[11930.]—**Brick Ornament.**—It will be better to set the bricks in position in the building, and carve *in situ*.—H. L.

[11931.]—**Plumbing Fittings.**—"Learner" does not state whether he is an architect or a plumber; but if the latter, he will learn all such matters by experience. There are good books on plumbers' work by Messrs. Buchan, Hellyer, and Clarke, respectively.—H. L.

[11932.]—**Photography for Architects.**—There are good elementary books on photography, such as Burton's "Modern Photography," Henry's "Early Work in Photography"; while, for the application of the art to architecture, there is a book called Mill's "Photography for Architects," and the best book on the subject "Architectural Photography," by G. A. T. Middleton. The latter is really good and very cheap.—HENRY LOVEGROVE.

[11932.]—**Photography for Architects.**—"Everyone's Guide to Photography," by E. J. Wall, F.R.P.S., will be found very useful for obtaining a knowledge of the development of plates, toning, &c. I should recommend a  $\frac{1}{2}$ -plate camera, as  $\frac{1}{4}$ -plate is too small for architectural detail, and whole-plate is too cumbersome for cycling and rambling. If only one lens is used, a wide-angle Rapid Rectilinear is to be preferred.—CYRIL DYSON.

[1192.]—**Photography for Architects.**—A book on the subject "T. F. M." writes about has just been published by Hazell, Watson, and Viney, Ltd., on "Architectural Photography," by G. A. T. Middleton, A.R.I.B.A., which will give practical lessons for the amateur, and is moderate in price.—G. W.

David Holland, 63 years of age, a clerk in the employment of the Manchester corporation, was charged before the magistrates of that city on Tuesday with conspiring with John Tetlow, said to be connected with a firm of earthenware pipe manufacturers, who is already in custody, to obtain from the corporation the sum of £56 18s. by means of false pretences, and also with conspiring to obtain £5,000 from the corporation during the past 10 years. He was remanded till Monday next, bail being granted. It was stated that the prisoner had been in the employ of the corporation for 22 years, recently in the highways department, and formerly under the city surveyor.

In 1894 the Rev. G. T. Braine-Hartnell, then vicar of Liskeard, died. As a tribute to his memory a large mural brass affixed to a black marble slab has been placed in the chancel of the parish church. The edifice is being further enriched by a second carved parclose screen of oak being placed on the north side of the chancel.

At the last meeting of the Dublin Corporation a report of a deputation which recently visited several large English centres was adopted with reference to the fire brigade, and, as a result, several improvements are to be taken in hand. A large central station is to be erected as near O'Connell Bridge as possible, and there are also to be four sub-stations in various parts of the city. A system of electric street alarms is to be provided, and horizontal fire escapes are also to be introduced, as, owing to the overhead wires of the electric tram system, there will in future be difficulty in manipulating the vertical escapes in the leading thoroughfares. It was decided to borrow £20,000 to procure new electric cables and erect four sub-transformer stations in connection with the existing installations.

## LEGAL INTELLIGENCE.

**DIRECT COMMUNICATION BETWEEN STREETS.—WOODHAM V. LONDON COUNTY COUNCIL.**—Judgment has been given in this appeal by Mr. Justice Day and Mr. Justice Phillimore. The plaintiff desired to make a new road at Catford, running from Laleham-road, and after some distance turning at right angles, and communicating with Brownhill-road. By section 9, subsection 4, of the London Building Act, 1894, it is provided that it shall be lawful for the London County Council to refuse to sanction the formation of a street where the street is proposed to be formed or laid out in such a manner that it will not afford direct communication between two existing streets. The county council held that the street proposed to be formed must be a straight street communication between two existing streets, and so refused to sanction the plaintiff's undertaking. The plaintiff thereupon appealed to the tribunal of appeal constituted under section 175 of the same Act, and that body upheld the opinion of the county council. An order was then made by the judge in chambers for a special case under section 182 of the Act to be stated, for the purpose of determining any question of law arising on the case in question. Mr. R. M. Bray, Q.C., for the plaintiff, submitted that the meaning of the words "direct communication between two streets" was a question of law for their lordships' interpretation, and that the proposed new street was a direct communication, although it was not a straight road. He cited "London County Council v. Edmonson" (66 L.T., N.S., 200). Mr. Horace Avory (for the London County Council) contended that the question raised was essentially one of fact to be dealt with by the Council. The tribunal of appeal had been constituted for safeguarding landowners wishing to lay out their land and for deciding questions of fact. The matter had been before both these bodies, and they had exercised their discretion. Mr. Justice Day: I am of opinion that this is a question of fact, on which both the London County Council and the tribunal of appeal have pronounced their opinion, and I see no reason to differ from them. Mr. Justice Phillimore: I quite agree. I think the words "direct communication" are a matter for the County Council, and we cannot interfere. The appeal was therefore dismissed.

## CHIPS.

In the list of adjudications in bankruptcy, published in Tuesday's *London Gazette*, the name appears of Richard Arthur Bullivant, of Leeds, architect and builder.

Sir Wyke Bayliss, P.R.B.A., will deliver an address to-morrow (Saturday) at the galleries of the Royal Society of British Artists, Suffolk-street, on "Art in the House of Her Friends." The lecture, which will be addressed to members and friends of the society, will be delivered at 4 p.m.

A new altar table has been given to the parish church of St. Cuthbert, Lytham. The altar is of oak, carved in Gothic panels, in keeping with the design of the reredos, and is the work of Messrs. Jones and Willis, of Birmingham. It will bear a plate to the effect that it is a memorial gift, and was dedicated on Saturday afternoon.

Subscriptions continue to flow in from all parts of the country towards the fund for the restoration of the ancient cathedral at Brechin, N.B. The fund is managed by a large committee, and the sum aimed at is £10,000. The amount received up to the end of March was slightly over \$5,100, so that fully one-half of the total has now been collected.

The conversion of the plot of land in close proximity to the Waterfall Gardens and the railway at Truro into a public park, as a memorial of the Diamond Jubilee, is rapidly approaching completion. Messrs. Henderson and Son, civil engineers, whose plans were chosen, also secured the contract for the work.

The Marquis of Ripon, K.G., performed on Monday the opening ceremony in connection with new Roman Catholic schools in St. Mary's parish, Bradford. The buildings are situated in Stott-hill, and occupy the site of an erection which was formerly used as St. Mary's church, and afterwards as day-schools. The new premises will accommodate 1,115 children—622 girls and 493 infants—and there are also clubrooms.

The discovery has been made at Blyth, near Retford, that the hill on which is situated the village school and the Green is really a barrow, or artificial mound, used as a place of interment for pre-historic races. During the removal of the foundations of a row of cottages on the Green, skulls and other bones were found, including a neolithic human skull and the bones of a horse. These were found in cists, made of a large number of small stones, and having a vaulted appearance. Last week a bored pebble was found on the hill. It was of an ordinary quartzite boulder, bored on each side by human agency, and having the shape of an axe.

## Our Office Table.

MR. CHARLES LOCK EASTLAKE, F.R.I.B.A., having reached the age limit, has retired from the post of keeper of the National Gallery and secretary and accounting officer to the trustees, and the Treasury has appointed Mr. Hawes H. Turner to that office. Mr. Eastlake was educated as an architect, and preceded the late Mr. W. H. White as secretary to the Royal Institute of British Architects. About twenty years ago he obtained the office he now vacates; since then to him have been committed the detailed management of the Gallery, the correspondence not requiring the direct authority of the trustees and directors, and the hanging of pictures. Some years since he contributed a series of articles to our columns on "Old Masters" at the National Gallery and on the Continent. The trustees and director of the National Gallery have passed a resolution respecting the recent retirement of Mr. Eastlake. They regret that Mr. Eastlake is obliged, under the regulations of the Civil Service, to retire from his duties, and express their thanks for the efficient manner in which he has discharged those duties during the twenty years of his services as keeper and secretary of the Gallery.

THE annual exhibition of work by the art students at the Technical School, under the control of the Technical Education Board of the London County Council, was opened on Wednesday in one of the large rooms of the building in Bolt-court, Fleet-street. The collection of exhibits includes specimens of drawing from the life and from the cast, and also drawing as applied to "process." At the present time there are about 200 lads and young men receiving regular instruction either in the art or technical department of the school, all of whom are genuinely engaged in some branch of the photo-mechanical, photographic, designing, lithographic, engraving, and printing crafts. The exhibition, to which admission is free, will remain open till to-morrow (Saturday) evening.

A NEW factory which Messrs. Hall and Fenton, of St. James's-row, Sheffield, have designed for Messrs. Walker and Hall, to be erected on a portion of the site of their present establishment in Howard-street, will be a unique object in the architecture of that city. It is to consist of nine floors, and a flat roof protected with a parapet of ornamental ironwork, upon which, at an elevation of more than 100ft., it will be possible to take the air and obtain a bird's-eye view of Sheffield. Thus it will be the highest building devoted to commerce in the city. As the ground dimensions are only 80ft. by 26ft., the place will present the appearance of an oblong tower. The factory will be faced throughout with white glazed bricks, the beams and joists are to be of steel, and the floors of concrete. The new building will provide accommodation for upwards of 700 workmen, who will ascend to their shops by the means of an elevator.

THE maximum height to which buildings may be lawfully carried in Chicago has just been reduced from 155ft., the former limit, to 130ft. This will, under ordinary circumstances, give room for ten stories, in place of the twelve stories which could be put into 155ft. The present limit in Boston is 125ft., which admits ten rather low stories as against the statutory 90ft. of the new London Building Act. Recently, a bill was introduced into the State Legislature for reducing the limit to 100ft., by a general law, applying to the whole State of Massachusetts; but it failed to meet the approval of the committee to which it was referred, and it is probable that nothing more will be heard of it. As 125ft. will only with difficulty admit ten stories, 100ft. would allow, under the heights of rooms permissible in Massachusetts, only seven, which would occupy, in ordinary mercantile buildings and hotels, about 92ft., leaving a waste space of 8ft., too low for an additional story, and unnecessary for roof-space.

THE Sun Life Assurance Society's report and accounts for the year ending 31st December last abundantly justify the opinion we have always expressed of the position of this admirably managed company. The following are the salient points:—2,329 new "life" policies were issued, assuring £1,092,382, after deduction of re-assurances, with premiums £43,939. The "life" premium income was £419,986, and interest, dividends, and rents produced £135,026; the

average rate of interest being £4 4s. 3d. per cent. The total "life" income amounted to £555,221. Claims were well within the expectation, and amounted to £235,224, including bonus additions; cash bonuses to policy holders to £91,534. Surrenders were £20,855, and commission and expenses of management, including expenses of valuation and distribution of bonus, £69,057. These, with smaller items, made the total "life" outgo £472,520. Annuities were granted during the year for £6,789, the consideration money received being £55,217. The total funds have been raised in the year from £3,672,755 to £3,957,198, being an increase of £284,443. An accident and general department has been established for the transaction of personal accident, employers' liability and workmen's compensation insurance, which many readers will find advantageous.

Mr. Adam Teacher, proprietor of several licensed houses, who died at Glasgow last week, has left £50,000 to local charities, and has bequeathed all his pictures to the Glasgow Corporation.

A portrait of Sir Arthur Arnold is being painted, by subscription of members of the London County Council, to be placed in the County Hall, Spring-gardens.

New county schools are about to be erected at Mold. Mr. Thomas Roberts, of New-street, Mold, is the contractor, and Mr. Edward Bradshaw, of Denbigh, is the clerk of works.

At the last meeting of the Kilmarnock Town Council Provost Mackay intimated that offers for the erection of the museum, towards which Mr. Dick, of Glasgow, had gifted £8,000, amounted to £11,176, and that Mr. Dick had increased his gift to that amount rather than that the plans should be interfered with.

A memorial stained-glass window has been placed in St. Luke's, Bolton. It is one of a series, illustrating the Te Deum. The figures are of St. Aidan and St. Cuthbert, two of the earliest missionaries to Northumbria.

St. Mary's Church at Evedon, near Sleaford, was reopened, after restoration and enlargement, on Tuesday. New stained-glass windows have been inserted at the east and west ends, the old boxes replaced by handsome oak seats, and the whole of the interior remodelled and restored. The work has been done at a cost of £500. It is hoped in the near future to procure a better organ and rehang the bells.

On Palm Sunday the Bishop of St. Asaph dedicated a stained-glass window in Whitford parish church, Flintshire, in memory of the late Lord and Lady Mostyn. The window is an east light on the Mostyn side of the church. It contains four subjects, representing "The Adoration of the Wise Men," "Our Lord's Presentation in the Temple," "Our Lord's Subjection to His Parents," and "The Carpenter's Shop."

Bradford old Parish Church is in the hands of the restorers, and is being thoroughly overhauled and made presentable in view of the opening of the Church Congress in that town in the autumn. Galleries and pews have been removed, and the stone walls relieved of plaster.

The first annual meeting of the West of England and South Wales Federation of Master Builders will be held at Bath on the 3rd May, and the newly-formed Bristol Cabinet Federation will hold its annual dinner on the 7th proximo.

Up to the present the expenditure on Wentwood Waterworks at Llanvaches, Mon., by the Newport Corporation, has been £113,930. The work is being proceeded with rapidly, over 200 men being engaged.

A service was held at Tewkesbury Abbey on Tuesday to dedicate a coloured-glass window, which has been erected to the memory of the late Mr. B. T. Moore, who for 38 years was warden of the abbey. The window is in St. Faith's Chapel, in the ambulatory, and represents St. Faith in the centre light and St. Cecilia and St. Agnes in either of the side-lights, the figures being three-quarter length.

A chancel screen, erected in the church of St. John the Baptist, Atherton, was dedicated on Palm Sunday. It has been designed to take the place of the low stone screen wall which ran across the entrance of the chancel. It is of oak, 26ft. wide and 16ft. high, and stands on a stone base 12in. deep. It is seven bays wide, the centre bay 5ft. wide, and that on the extreme north forming the entrance to the pulpit. The lower portion is solid panelled, with carved linen panels, the head of the screen being filled in with carved tracery panels. From the caps of the shafts on the west side of the screen next the nave springs a groined canopied ceiling, which supports the cornice. The screen has been designed and superintended by the architects of the church, Messrs. Austin and Paley, of Lancaster.

MEETINGS FOR THE ENSUING WEEK.

**MONDAY.**—Society of Arts. "Indiarubber," Cantor Lecture No. 1, by Dr. D. Morris, C.M.G. 8 p.m.  
 Royal Institute of British Architects. "Domestic Architecture in the United States," by A. N. Paterson, M.A. 8 p.m.  
 Liverpool Architectural Society. Jubilee Dinner, at Walker Art Gallery.

**TUESDAY.**—Institution of Civil Engineers. Discussion on "The Electricity Supply of London." 8 p.m.

**WEDNESDAY.**—Surveyors' Institution. Meeting at Manchester. (1) "Manchester from 1847 to 1897," by John Holden, of Manchester; (2) "Lessons from Fire and Panic," by T. Blashill, Superintending Architect London County Council; (3) "A Consideration of some of the Present-day Difficulties met with in a Land Agent's Practice," by C. P. Hall; and (4) "Notes on the Construction of Town Buildings," by Howard Chatfield Clarke. Town Hall. 11 a.m.  
 Society of Arts. "Stage Mechanism," by Edwin O. Sachs. 8 p.m.  
 Edinburgh Architectural Society. "Sculpture in Relation to Architecture," by T. Duncan Rhind, A.R.I.B.A. 8 p.m.

**THURSDAY.**—Society of Architects. Annual Dinner. St. James's Hall, Piccadilly, W. 6.30 for 7 p.m.  
 Society of Arts. "Recent Railway Policy in India," by Horace Bell, M.Inst.C.E. 4.30 p.m.

**FRIDAY.**—Architectural Assoc. on. "The Morality and Economy of Competitions," by H. B. Cresswell. 7.30 p.m.

**THE ARCHITECTURAL ASSOCIATION.**  
 APRIL 22nd, ORDINARY GENERAL MEETING, No. 9, Conduit-street, W., 7.30 p.m. Mr. H. B. CRESSWELL on "THE MORALITY AND ECONOMY OF COMPETITIONS."  
 E. HOWLEY SIM } Hon. Secs.  
 G. B. CARVILL }

CHIPS.

The Lycett Wesleyan Memorial Chapel, in the Mile End-road, was partially destroyed by fire on Wednesday in last week.

The urban district council of Sevenoaks have raised the salary of their surveyor to £276 per annum.

The members of the Edinburgh Architectural Society met on the 6th inst. (Mr. W. N. Cumming, A.R.I.B.A., in the chair), when a lecture was given by Mr. John Kennedy on "Building Stones: their Preparation and Use." The lecturer insisted on the necessity of architects knowing more about the stones they employed, and described and classified building stones, their various dressings, and their special purposes.

It is stated that Mr. J. Passmore Edwards will lay the foundation-stone of the Public Library, Launceston, in May.

The Bayham Abbey Ruins, near Tunbridge Wells, will for some time to come be closed to the public, in consequence of the dangerous state of some of the old walls. The Marquis Camden has been advised, for the safety of the public, to close the grounds until such renovation as is permissible can be made.

Messrs. E. H. Shorland and Brother, of Manchester, have just supplied some more of their patent Manchester grates to the Royal Infirmary, Wigan.

With the object of celebrating the jubilee of the Liverpool Architectural Society, the president and council of the body have issued invitations for a banquet on the evening of Monday next, the 18th inst., which, by permission of the corporation committee controlling the Walker Gallery in the city, will be held in one of the rooms of the Spring Exhibition.

Plans have been approved by the Hornsey Urban District Council for the drainage, fencing, and laying-out of Churchyard Bottom Wood, Highgate, which has just been secured for the use of the public. It is proposed to interfere as little as possible with the present features of the wood, but a lodge will be erected and a park-keeper engaged to reside there permanently.

The town council of Tunbridge Wells have purchased a small estate, on which they propose to erect dwellings for the working class. The borough surveyor has been instructed to prepare plans and estimates for roads, sewers, fences, &c., for the land acquired; and also for 10 two-roomed houses, 40 four-roomed houses, 30 five-roomed houses, and 20 six-roomed houses.

The Wallasey Urban District Council have adopted a scheme of the works committee for purchasing land to widen Rowson-street, New Brighton, in view of probable tramway extension there. The council have also approved the purchase of Liscard Vale and College, containing about 33,700 square yards of land, as a public park, at a cost of £7,750.

Trade News.

WAGES MOVEMENTS.

**ARBOATH.**—The strike of the Arbroath joiners, which had lasted about a week, came to an end on Thursday in last week. The masters have given in to the demands of the men, and signed the by-laws. Under the new arrangement, wages will be paid at the rate of time and a quarter for work done after a day of eight hours during winter, and an additional 1s. will also be paid for work done in the country district. Work has been resumed.

**FAREHAM, HANTS.**—The builders' employees have applied for a rise of 1d. per hour all round, to take effect on May 2.

**LEEDS.**—The men in the Leeds building trades lately gave notice for an advance of wages. The masons, who asked for 3d. per hour advance, have had their demand granted, their request for overtime being withdrawn. The plasterers asked for 1d. per hour advance, and the masters offer 3d., which has not yet been accepted. The joiners demand 3d. per hour advance.

**NEWPORT, MON.**—The Newport branch of the Amalgamated Society of Carpenters and Joiners have refused the masters' request to withdraw the ban on a certain "shoo," and the masters' association have therefore locked out the men. About 200 men are affected.

**SCARBOROUGH.**—The plumbers of this town struck work last April for an increase in their wages from 7 1/2d. to 8 1/2d. per hour, and after an interval of about four weeks the men recommenced work at 8d. per hour. It was then agreed that the number of operative plumbers working in the town on April 3, 1897, be stated and verified, and that if the same number continued at work on April 3, 1898, the wages be advanced to 8 1/2d. per hour. It has now transpired that the number of operatives engaged in the town on the latter date was eight less, and so the wages will remain at 8d. per hour.

Mr. W. O. E. Meade-King, Local Government Board inspector, attended at the Court House, Stowmarket, Suffolk, on Wednesday week, to hold an inquiry as to the application of the Stowmarket Rural District Council and the East Stow Rural District Council for the sanction to the borrowing of £5,100 for a joint scheme for sewerage and sewage disposal.

An addition is about to be made to St. Matthew's Church, Westtown, by the erection of a memorial chapel. The structure will be placed on the south side of the chancel, and will be entered from the corresponding aisle of the nave. The present sitting accommodation in the church is for 575 worshippers, and is insufficient. The chapel will correspond in style with the architecture of the church.

A new senior public school and secondary department of the West Calder School Board were opened last week. The school is estimated to cost £4,900, and has accommodation for 450 scholars, including a secondary education department.

Liskeard and Looe Railway has been purchased by a company in London, who will immediately construct a new line from Looe to connect it with the Great Western Railway at Liskeard station. Mr. J. C. Lang has secured the contract, and will commence operations almost at once.

An external pulpit of stone is being built at St. Martin's Church, Birmingham, in the angle of the tower buttresses.

The Countess of Rosse, Womersley Hall, has given a new quarter-chime clock to Womersley Parish Church, which was set going by her Ladyship on Saturday noon. The clock was made and fixed by Messrs. William Potts and Sons, of Guildford-street, Leeds.

The rural district council of Keynsham have adopted plans by Mr. Bennett, C.E., for the sewerage of Keynsham, at an estimated cost of £14,000.

The Local Government Board have refused to sanction the application of the Peterborough Town Council for a loan of £30,000 for electric lighting in the city.

The amended estimates for the total cost of the Greenwich tunnel, including land, compensation, and works, amount to £155,150. In February last tenders for the work were invited from six selected firms. Two tenders only were received—one from Messrs. Mowlem and Co. amounting to £119,732, and the other from Messrs. Pearson and Son amounting to £155,000. As the expenditure provided for under the Act obtained by the London County Council authorising the introduction of the tunnel is only £70,500, the Council is taking steps to obtain Parliamentary sanction for the additional outlay, and in the mean time the acceptance of tenders is postponed.

LATEST PRICES.

IRON, &c.		Per ton.	Per ton.
Rolled-Iron Joists, Belgian	.....	£6 0 0	to £6 10 0
Rolled-Steel Joists, English	.....	6 10 0	to 7 0 0
Wrought-Iron Girder Plates	.....	5 15 0	to 6 10 0
Bar Iron, good Staffs	.....	7 0 0	to 8 0 0
Do., Lowmoor, Flat, Round, or Square	.....	17 0 0	to 17 5 0
Do., Welsh	.....	5 15 0	to 5 17 6
Boiler Plates, Iron—			
South Staffs	.....	7 17 6	to 8 5 0
Best Snedshill	.....	10 0 0	to 10 10 0
Angles 10s. Tees 20s. per ton extra.			
Builders' Hoop Iron, for bonding, &c.,	.....	£8 15s. 0d.	per ton.
Builders' Hoop Iron, galvanised,	.....	£15 10s. 0d.	per ton.
Galvanised Corrugated Sheet Iron—			
No. 18 to 20.	.....	No. 22 to 24.	.....
6ft. to 8ft. long, inclusive gauge	.....	£10 15 0	to £11 0 0
Best ditto	.....	11 5 0	to 11 10 0
Per ton.			
Cast-Iron Columns	.....	£8 0 0	to £9 10 0
Cast-Iron Stanchions	.....	6 0 0	to 8 10 0
Rolled-Iron Fencing Wire	.....	7 0 0	to 8 0 0
Rolled-Steel Fencing Wire	.....	7 6 0	to 7 10 0
Galvanised	.....	10 10 0	to 11 10 0
Cast-Iron Sash Weights	.....	4 0 0	to 4 2 6
Cast-Iron Socket Pipes—			
3in. diameter	.....	5 10 0	to 5 15 0
4in. to 6in.	.....	5 5 0	to 5 10 0
7in. to 24in. (all sizes)	.....	4 15 0	to 5 0 0
[Coated with composition, 2s. 6d. per ton extra; turned and bored joints, 5s. per ton extra.]			
Fig Iron—			
Cold Blast, Lilleshall	.....	105s. to 110s.	
Hot Blast, ditto	.....	57s. 6d. to 62s. 6d.	
Wrought-Iron Tubes—Discount off Standard Lists f.o.b.			
Gas-Tubes	.....	75p.c. Fittings	77 1/2 p.c.
Water-Tubes	.....	70	to 75
Steam-Tubes	.....	62 1/2	to 68
Galvanised Gas-Tubes	.....	60	to 62 1/2
Galvanised Water-Tubes	.....	55	to 57 1/2
Galvanised Steam-Tubes	.....	45	to 47 1/2
10cwt. casks. 5cwt. casks.			
Sheet Zinc, for roofing and working up	.....	£22 10 0	to £23 10 0
Sheet Lead, 3lb. per sq. ft. super.	.....	14 10 0	to 15 10 0
Fig Lead, in lwt. pigs	.....	14 0 0	to 15 0 0
Lead Shot, in 28lb. bags	.....	17 10 0	to 18 10 0
Copper Sheets, sheathing and rods	.....	62 0 0	to 68 0 0
Copper, British Cake and Ingots	.....	51 15 0	to 52 15 0
Tin, Straits	.....	66 3 9	to 67 3 9
Do., English Ingots	.....	69 0 0	to 70 0 0
Spelter, Silesian	.....	17 17 0	to 18 17 0
Cut Clasp Nails, 3in. to 6in.	.....	8 15 0	to 9 15 0
Cut Floor Brads	.....	8 10 0	to 9 10 0
Wire Nails (Points de Paris)—			
0 to 7	8 9 10 11 12 13 14 15	B.W.G.	
8/6 9/0 9/6 10/3 11/0 12/0 13/0 14/9 16/9		per cwt.	
<b>TIMBER.</b>			
Teak, Burmah	.....	per load £13 0 0	to £14 10 0
Bangkok	.....	9 0 0	to 14 0 0
Quebec pine, yellow	.....	2 5 0	to 4 5 0
Oak	.....	3 15 0	to 5 0 0
Birch	.....	2 17 6	to 4 10 0
Elm	.....	3 12 6	to 4 12 6
Ash	.....	2 17 6	to 4 2 6
Dantaic and Memel Oak	.....	2 4 0	to 3 4 0
Fir	.....	1 11 0	to 3 11 0
Wainscot, Riga p. log	.....	3 12 6	to 5 10 0
Lath, Dantaic, p.f.	.....	4 10 0	to 5 10 0
St. Petersburg	.....	5 0 0	to 6 10 0
Greenheart	.....	8 0 0	to 8 10 0
Box	.....	4 11 0	to 15 0 0
Sequoia, U.S.A. ... per cube foot	.....	0 1 8	to 0 1 10
Mahogany, Cuba, per super foot			
1in. thick	.....	0 0 5	to 0 0 6 1/2
Honduras	.....	0 0 4 1/2	to 0 0 6 1/2
Mexican	.....	0 0 4	to 0 0 5
Cedar, Cuba	.....	0 0 4	to 0 0 4 1/2
Honduras	.....	0 0 33	to 0 0 4 1/2
Satinwood	.....	0 0 5	to 0 1 0
Walnut, Italian	.....	0 0 3	to 0 0 7
Deals, per St. Petersburg Standard, 120—12ft. by 1 1/2in. by 1 1/2in.:			
Quebec, Pine, 1st	.....	£19 5 0	to £25 5 0
" 2nd	.....	13 15 0	to 16 5 0
" 3rd	.....	6 5 0	to 10 15 0
Canada Spruce, 1st	.....	10 0 0	to 11 10 0
" 2nd and 3rd	.....	7 10 0	to 8 10 0
New Brunswick	.....	7 0 0	to 7 10 0
Riga	.....	6 5 0	to 7 5 0
St. Petersburg	.....	8 5 0	to 12 5 0
Swedish	.....	8 15 0	to 15 5 0
Finland	.....	7 15 0	to 8 5 0
White Sea	.....	9 5 0	to 15 10 0
Battens, all sorts	.....	5 0 0	to 18 0 0
Flooring Boards, per square of lin.—			
1st prepared	.....	£0 9 6	to £0 17 0
2nd ditto	.....	0 8 0	to 0 13 6
Other qualities	.....	0 6 6	to 0 7 6
Staves, per standard M:—			
Quebec pipe	.....	235 0 0	to £210 0 0
U.S. ditto	.....	230 0 0	to 240 0 0
Memel, cr. pipe	.....	200 0 0	to 210 0 0
Memel, brack	.....	200 0 0	to 210 0 0
<b>OILS.</b>			
Linseed	.....	per ton. £15 10 0	to £16 0 0
Raped, English pale	.....	24 5 0	to 24 10 0
Do., brown	.....	22 10 0	to 23 0 0
Cottonseed, refined	.....	14 15 0	to 15 5 0
Olive, Spanish	.....	33 0 0	to 33 10 0
Seal, pale	.....	23 15 0	to 24 0 0
Cocoanut, Cochin	.....	27 15 0	to 28 0 0
Do., Ceylon	.....	22 0 0	to 23 5 0
Palm, Lagos	.....	18 15 0	to 19 15 0
Oleins	.....	0 6 3	to 0 7 6
Lubricating U.S. per gal.	.....	0 0 4 1/2	to 0 0 4 3/4
Petroleum, refined	.....	1 0 0	to 1 5 0
Tar, Stockholm	.....	per barrel	
Do., Archangel	.....	0 12 8	to 0 15 0
Turpentine, American	.....	per ton	
Do.,	.....	23 10 0	to 24 0 0

# THE BUILDING NEWS

## AND ENGINEERING JOURNAL.

VOL. LXXIV.—No. 2259.

FRIDAY, APRIL 22, 1898.

### CLOTHING IDEAS.

SOME time ago an advertisement in a journal devoted to literature ran as follows:—"The advertiser wants a literary amateur to put his ideas into fluent and stylish English." There are hundreds of men who have ideas which they cannot utilise or turn to account. One thing they want is the art of "licking them into shape," of expressing them in readable language. Hundreds of people would add to the ranks of fiction writers and novelists, or would write books on science or art if they only possessed the gift of expressing themselves with fluency. And it is exactly the same in other fields. We find men who have inventive minds stranded because their education has not allowed them to turn their invention to the best account, or because their project is not new, after all. They are not mechanician, mathematician, or chemist enough to have discovered where they have failed. There are also manufacturers who have brought out really good things, but have not been fortunate enough to present them in the best form. We could name manufacturers of materials like brick, terracotta, faience, inventors of appliances like ventilators, who have failed to set forth their work in a favourable light. They are contented with indifferent or positively objectionable designs; their mouldings or ornamental details are poor—often out of date or extremely showy. These are certainly drawbacks to many of our manufactured goods. Capital, machinery, industry, appliances, all that can assist the turn-out are in every way admirable; but the one thing that is wanting is the art sense. We are able to manufacture anything, says the enterprising tradesman, that the architect can ask for, but his requirements come too late, and the firm make their own designs; often they engage competent artists to do their work, and it is done well. The said artist is in touch with the manufacturer or craftsmen; he gets familiar with the material, with its requirements and limitations, and his work ought to be satisfactory. But the popular demand for ornament is often too great even to resist. Do we not find this especially so in ironmongery, grates, chimney-pieces, and furniture?

If we turn to the architect's work, we have to acknowledge that the advertised for "clothes of ideas" is quite as much in evidence. The successful planner of workhouses, hospitals, or baths owes much of his success to the artistic draughtsman. He is perhaps the "ghost" in all but name; his existence may be more sedulously obscured as the manifestation of his genius becomes clearer. The man who can write fluent English and put a crude idea into shape, or describe a plot in winning phrase, often shares the honour of the work, even if he is only giving expression to the invention of another, so also the clever draughtsman who gives interest and colour to a very commonplace building deserves to be recognised, at least, as joint author of the design. After all, the man who can clothe in agreeable architecture a clever or well-adapted plan has a claim to be recognised. Pugin's taste and skill in Gothic detail is even now acknowledged when we look at and admire the splendid pile which fringes our riverside at Westminster. It required undoubted ability to plan so complex a building as a House for the Legislature of a great nation; but must we not also acknowledge the architectural skill which we see in the grouping of parts, and the refined Tudor

details of the wonderful but over-wrought façade. The outward dress is, or ought to be, the correlative of good plan. In the architectural profession we are constantly reminded of the existence of these two functions, almost distinct and separate, yet depending on each other. They seem sometimes to unite and combine in the same individual, but more often they are almost irreconcilable, as some of our more important public buildings testify; and it is this dual nature of modern architectural practice—we cannot say that it was always so—that has set the face of Parliament against a public competition for the proposed new Government Buildings. The authorities ask for an artist who can clothe their own buildings. The experience of Government officials and others has been that a public competition draws out both sides of architecture—men who can plan good offices but who cannot design buildings worthy of the country, and men, on the other side, skilled as artists, who have no knowledge of practical requirements. Between these two classes our national architecture has suffered. We look to other nations like France and Belgium for models of union between the useful and the artistic. Such being the belief, the popular idea is, Get a practical man to draw the plans and superintend the work, and employ an architect to clothe his building in appropriate habiliments. Nothing easier to the ordinary man; but has it ever been crowned with success? Have we not several buildings in London and the provincial towns illustrating the impracticability of the coalition?—of pinched and parsimonious interiors clothed with tawdry finery outside, or a result in which the co-operation has been anything but cordial when the official architect and the art designer or clothier have not been on the best of terms, the latter attempting to disguise rather than express the plan? And will any future Government buildings carried out on this system of divided authority show better results? The Whitehall buildings which have been so criticised by Sir W. Harcourt and Sir Henry Campbell-Bannerman are instances of clothed buildings of this description. They are conspicuous instances of buildings in which official ideas have been clothed to suit the style of the day. We have no proof that these separate functions have given success, or that division of labour in the design has been worthy of the effort. Open competition has presumably failed because favouritism or party influence has been in the ascendant. A competition conducted on a proper basis, and in accordance with more recent experiences and safeguards, is more likely to produce a combination of good arrangement and design. It has failed hitherto because the right methods have not been followed. Large premiums have been offered to the profession for "designs," without any reference to actual requirements, and crude ideas clothed in attractive garments have been sent in. We have here a contest appealing to the mere getter-up of architectural designs, where the expert artist has the better chance. The consequence is that a well thought out design is in the minority. But this condition of things no longer prevails. Under a properly prepared set of conditions with efficient assessors, two or three at the least, it is possible to obtain an amalgamation of the desired qualities—plan and elevation. The tricky perspective has less chance of winning than it had formerly, and more attention is given to plan. Separation in architecture—by which we mean the engagement of two individuals, one as builder the other as "artist"—is wrong in principle, and based on the idea that plan and external expression are different duties, and modern practice has sanctioned the fallacy. Public official architecture worthy of the age is not likely to be obtained in the way proposed.

### MODEL SPECIFICATIONS.—IX.

#### TERRACOTTA.

BY an almost natural transition, we pass from brickwork to terracotta. The illustrative designs we have given for brickwork may, with few exceptions, be produced in terracotta. So we shall only add examples of the application. Of course, there are limitations, such as coursing with brickwork, in facing brick walls, dimensions of blocks, &c. Great projections should be avoided; but, generally speaking, any design that can be executed in brick or stone may be made in this material, though it is not advisable to imitate stonework. The sketches we give comprise ornamental window-sills that can be made or moulded in terracotta, as in the case of the corbelling for oriel windows, Fig. 3, one-half of which is shown in cut and gauged brickwork. Fig. 5 is a good example of a terracotta set of base or plinth mouldings for an arcade, though suitable also for stone. We also show examples of terracotta dormers or gables and door-heads.

It may be desirable to remark that the clay most suitable for the production of brick or terracotta is that which contains a silica and alumina in the proportion of about 60 to 65 parts of silica to 20 or 25 parts of alumina with a small percentage of potash and soda, and the remaining material ferruginous oxides. This kind of clay has been found in North Wales, as in the Ruabon district, at Tamworth, Staffordshire, Poole, in Dorsetshire, and other places. The colour is imparted by the oxides. The amount of shrinkage in clays is the most essential point for the architect if he wishes his designs to come out true in shape; hence he should be particular to select a clay that will not twist and warp when exposed to a great heat. With inferior clays sand, broken pottery, and glass are often mixed to reduce the shrinkage, owing to the large amount of moisture in the clay. If he desires also a good natural colour, he will be particular to require that no "dipping" with clay or artificial colouring is resorted to, which will last no time. Only with the clay can the artist's intentions be realised, and the modelling and colour be retained in the "fired" product. A clause to this effect should be used:—"The terracotta is to be well burnt, made from suitable clays, containing a due proportion of silica and oxides."

#### TERRACOTTA WORKER.

A few notes on this material may be useful. It is necessary to use caution in the employment of terracotta: it should not be subjected to considerable weight, as it is liable to crack. To avoid this risk as far as possible, the specification should insist that all blocks of the material be carefully set and the hollows filled up solid with cement or fine lime concrete in building up in the walls. The unequal shrinkage of terracotta ought to be borne in mind in designing the pieces to be burned. The blocks should average 1ft. 6in. to 3ft. cube, and the larger blocks made hollow should have a division or diaphragm to strengthen the sides; the thickness of shell not being less than 1½in., though 2in. is better. As the shrinkage varies, a "shrinkage rule" is adopted, which ought to be observed by the designer or modeller. Mixed clays contract from 1-10th to 1-12th of the linear dimensions on drying and firing, and red clays contract about 1-20th. It is necessary to provide full-size or "clay drawings" for important blocks; but the usual scale adopted is ½in. to the foot, and the dimensions should be figured. When terracotta blocks and dressings are to be set in brickwork, the dimensions of the former should be some multiple of a brick, in order to bond with the brick courses. The length of blocks ought not to exceed 18in.—one terracotta manufacturer says the largest

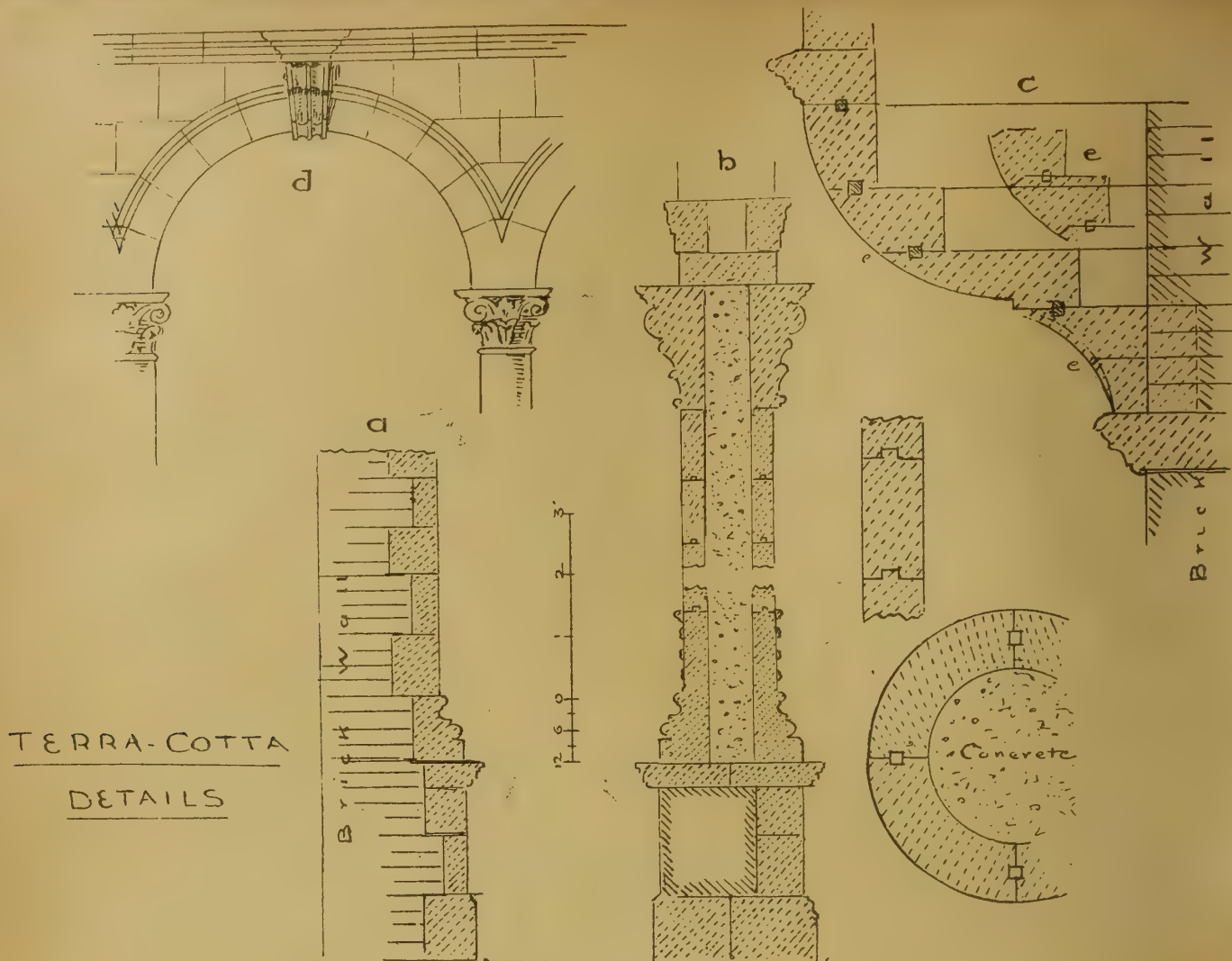

blocks should not be more than 18in. to 2ft. cube. In designing, the idea should be to follow ashlar work. Those designs are most suitable where the terracotta work has been well thought out, and the work arranged so that small blocks and many joints are a feature. Mr. Waterhouse allows wide joints, so as to produce equal settlement. These should be weathered, to throw off the water. Specification should state whether the blocks are to be chambered, if filled in before or after fixing with lime or Portland cement concrete, and the kind and colour of mortar. Shrinkage is prevented by pressing so as to insure uniform thickness of clay, and special care is necessary to dry well before firing, so as to obtain evenness of line and uniform colour. For lintels and arches joggled joints are often used.

Where repetitions of the same ornament or detail occur, terracotta offers advantages and is less costly than stone. We now give a few clauses of a general kind.

1. *Terracotta*.—The terracotta to be red (or stone colour), to be carefully modelled and moulded in accordance with the full-sized or detail drawings, allowing for shrinkage.

The pieces to be thoroughly burned, of uniform tint, free from cracks and other defects, the pieces, especially those of moulded plinths, string-courses, cornices, pilasters, &c., to have sharp arrises, and true in line. No cutting, filing, or rubbing is to be done after the firing. The blocks are to have "pockets" or hollows, and be filled with fine lime concrete (or breeze concrete) composed of one part Portland cement to four parts clean coke breeze—after being soaked in water, and to be bedded in Portland cement.

The joints to be not more than  $\frac{3}{16}$ in. or  $\frac{1}{4}$ in. thick, and pointed with coloured Portland cement.

Mr. Leaning gives the following general clause:—

The terracotta shall be red, of the best quality, well burnt, and of even colour, and where hollow

no part to be less than 2in. thick. None of the surfaces shall be coloured by an applied wash; none of the original surfaces to be filed, rubbed, or chipped unless they are concealed, and these surfaces are to be as little interfered with as may be. The hollows of the terracotta to be filled in with fine lime concrete, and the blocks to be previously soaked in water. No piece of terracotta shall, unless specially ordered, exceed 18in. cube. The terracotta shall be set in fine mortar, neatly pointed as the work proceeds, and cleaned down at completion. It shall be thoroughly bonded with and course with the brickwork, and no joint shall exceed a quarter of an inch in thickness. All the vertical and horizontal arrises to be left exactly true and regular. The whole to be set in mortar to match the facings, and pointed in a similar manner.

2. *Setting Out Work*.—The manufacturer (or contractor) to be responsible for the setting-out of all the terracotta work, and for the accuracy and size of each block; allowance to be made in every case for shrinkage. Each is to be marked for identification or arrangement in the building. No piece is to be filed or rubbed after the firing.

3. *Colour*.—The terracotta to be of uniform colour (or pleasingly blended shades of colour) of a tone approved by the architect.

4. *Facings of Terracotta*.—The brickwork to be faced with red or buff terracotta, manufactured by J. C. Edwards, Ruabon (or Doulton and Co., or the Hathern Station Brick Co.), 6in. thick, and of varying depths of from 3 to 4 courses, bonded to wall every square yard. The facing blocks to be laid on lime mortar with bevelled joints or pointed with coloured cement. The door and window dressings to be executed in well modelled moulded blocks according to details, no piece of terracotta being longer than 18in. (or 3ft. cube), the chambered blocks being filled up with fine lime (or Roman cement) concrete. The heads of windows and doors to have joggled joints as shown; the sills, cornices, pediments, and string-courses to be carefully modelled and jointed, as shown, and the arrises to be sharp and in true line. All warped, twisted, and cracked pieces will be rejected.

5. *General Dressings*.—The blocks for the plinths, pilasters, cornices, and window dressings to be

true in line, and to be modelled according to the full-size drawings supplied to the manufacturer, who has to apply his own shrinkage scale. The blocks are to be supplied before the brickwork is commenced, so as to avoid any delay to the bricklayers engaged. The fixing to be done by the manufacturer, or under the supervision of men experienced in the material, and the blocks are to be fixed or humoured to produce straightness of line. All large blocks to be webbed, and to have the least thickness of  $1\frac{1}{2}$ in. or 2in., and to be filled in with lime concrete.

6. *Vestibule*.—The vestibule (or loggia) to have the walls faced with terracotta in blocks, 3 (or 4) courses in height, and  $4\frac{1}{2}$ in. (or 6in.) thick, with a bonding block 9in. deep, every superficial yard laid in lime mortar pointed with a bevelled joint. The surbase mouldings and cornices to be of blocks not to exceed 12in. (or 18in.) long, breaking joint with facing. Or—

The plinth, dado, surbase, mouldings, wall-facing, and cornice of vestibule or corridor to be constructed of terracotta according to detail *a*; the larger blocks to be formed hollow, and webbed and filled in with fine lime concrete, the whole to be properly bonded to brick wall every 3ft. in height, and jointed with lime mortar and pointed. The blocks to be made to course with the brickwork, and be of three or four courses in height.

7. *Columns*.—The columns to be built of terracotta blocks 12in. (or 15in.) high, and 4in. or 5in. in thickness, accurately modelled, with alternate bonding courses of the whole diameter. The horizontal joints to be grooved and tongued, and the vertical joints dowelled by a square hole filled with cement (or a slate dowel). The centres of columns to be filled in with broken brick grouted with cement (or the terracotta casing may surround, but not touch, a cast-iron column). The joints are to be in putty cement,  $\frac{1}{4}$ in. thick, laid to within  $\frac{1}{4}$ in. of outside face. The pointing to be done after completion. Or—

The columns (see section *b*) are to be composed of segments of terracotta, accurately modelled, without twist or warp, having tongued and grooved joints in lime putty,  $\frac{1}{4}$ in. thick, with dowels of cement in the vertical joints, as shown.



Brick and Terra-Cotta

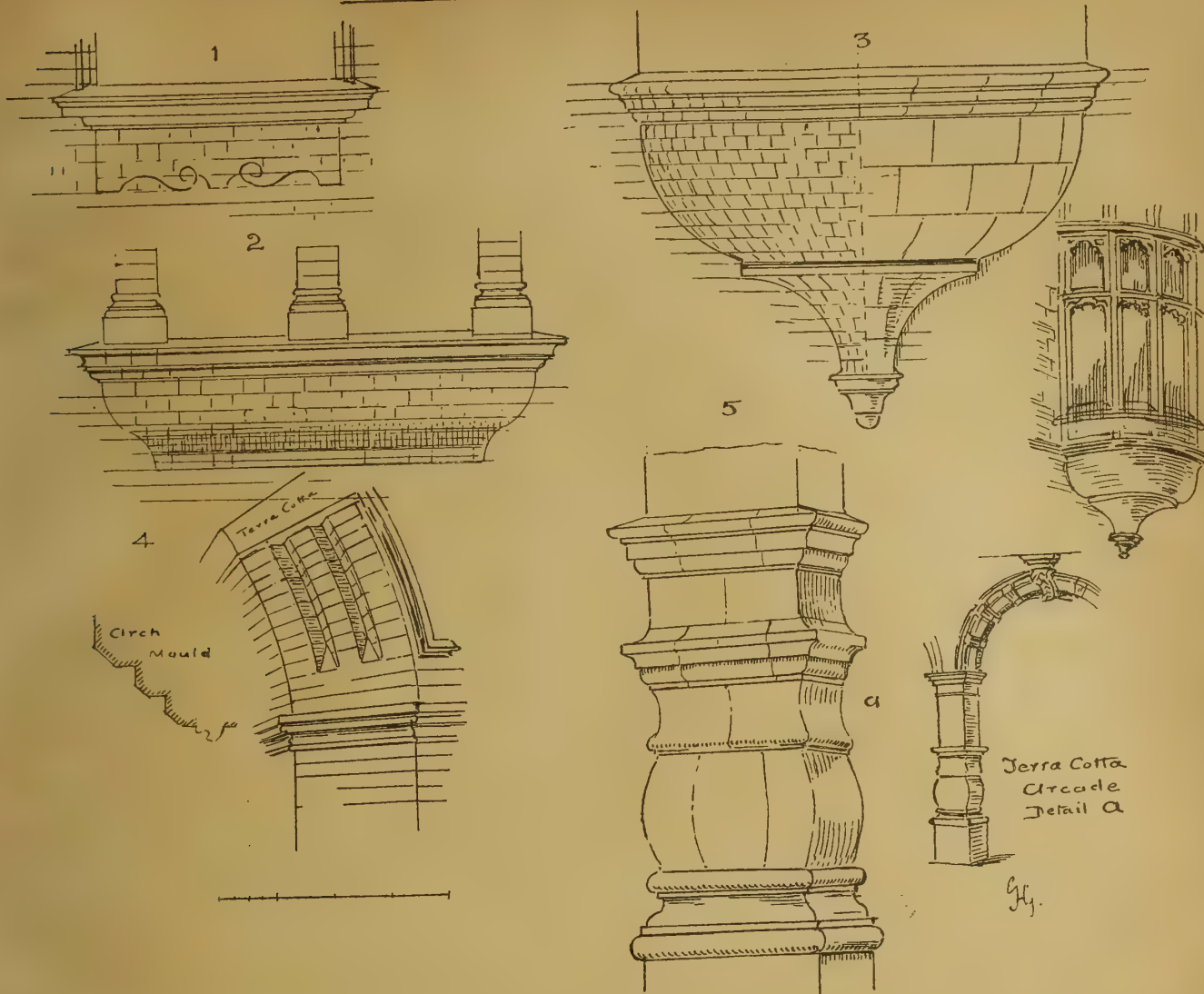

The centre to be filled up as the casing proceeds with broken brick and Roman cement concrete; or the terracotta casing is to be constructed round iron columns, the space filled in with concrete or some non-conducting substance like slag wool. The bases and capitals are also to be cast hollow, made in four pieces (or if small in one hollow block). Or—

Construct the columns according to design. The terracotta to be supplied by J. C. Edwards, of Ruabon, and to be made in cylindrical segments 3in. or 4in. thick, dowelled together, and with grooved and tongued joints, the pieces to be laid in cement mortar, and the centre cavity to be filled with fine Roman-cement concrete, levelled up as the pieces are fixed.

Most specifications are silent on constructive terracotta work. Where there is any considerable weight to carry, the column blocks would be better solid, in small pieces, bonded every other course, as in stonework, or, if hollow, the blocks should be filled up as the column is built. In most cases where this material is employed, it is for decorative purposes—such as for the columns carrying a floor on which there is no weight, for street façades, shop-fronts, in which it is used simply as a casing for iron columns or stanchions.

8. *Arches.*—The arcade (sketch *d*) to be constructed of properly radiating and moulded blocks of the size shown on details (allowance to be made for shrinkage in drying and burning), properly set out, laid in lime or cement mortar, with neat joints not to exceed  $\frac{1}{8}$ in. wide, pointed in coloured Portland cement. Or—

The blocks for the arcading to be accurately set out by the manufacturer (with the aid of the contractor or clerk of works) according to the working drawings, allowing for shrinkage; no chiselling or filing to be done after the firing, and to be turned to the proper curvature, jointed in

cement mortar, the joints not to be more than  $\frac{1}{8}$ in. thick, and to be pointed in coloured cement. The capitals of columns to be cast according to design, and to be approved by the architect; also the ornamental keystones. (If the blocks are chambered, state so, and the filling of the same with concrete.)

9. *Corbelling to Oriel.*—The terracotta blocks to be accurately set out and modelled to full-size drawings, with radiating joints properly shaped and bevelled, and “pinned” into the wall. The blocks to be grooved and tongued together, and the vertical joints between each to have a slate or cement dowel. Or—

Construct with terracotta blocks in courses, moulded to curve and shaped to proper radius, the oriel corbel shown in elevation (Fig. 3). The horizontal courses to be tongued and grooved (or joggled together, section *e*), set in fine mortar, and pointed with a bevelled joint. The springer or corbel and the next course to be built or tailed into the wall to the extent of 9in. (or 14in.) in cement, and each course of blocks to be bonded into the brick wall. The sill to be covered with 5lb. lead projecting to form a drip.

The following clause is applicable to a brick oriel, “gauged” and set in putty. For heavy oriel projections, a rolled-iron joist is fixed, bearing on the side jambs of opening at a height sufficient to allow the joists to rest upon it. Under the lower flange, “tailed” into the wall, York flags may be introduced to take the upper part of corbelling and oriel, so as to form a tailing-down or counterbalance to the weight above.

10. *Brick Corbelling.*—The projecting courses of corbelling to be set out full size, each course being made to radiate from centre of semicircle, and the face of each brick cut and rubbed to the necessary curve with proper bevels. Only headers to be used, set in a neat putty joint. A terracotta or stone springer tailed into the wall to be put in

below the lowest course of corbelling. The projecting string and sill courses to be of moulded bricks (see sketch), and to be covered with 5lb. lead projecting  $\frac{1}{2}$ in. to form a drip.

ROYAL INSTITUTE OF BRITISH ARCHITECTS.

A SPECIAL business meeting of this institution was held on Monday evening at 9, Conduit-street, W., the chair being occupied by Mr. H. Louis Florence, vice-president. The resolution passed at the special meeting, held a fortnight previously, suspending By-law 26 so as to allow of the re-election of Professor Aitchison, R.A., for a third year of office as president, was duly confirmed.

The Lords of the Privy Council having raised certain objections to ambiguities of wording in the additions and amendments to By-laws 30 and 9 as resolved at the special general meetings respectively held on the 14th June and the 13th November, 1897, such additions and amendments were altered by the meeting, after consideration and some discussion, as follows:—(a) By-law 91: Provided always that when the Council of the Institute receive a unanimous recommendation formally submitted by the Council of any Allied Society that a practising member of the profession is eligible and worthy of being elected as a Fellow, the Council shall, during the five years from the date of approval of this provision by the Privy Council, have power to elect him if in their opinion his work be of sufficient merit. The Council shall also have the power to elect annually to the Fellowship without ballot the President or President-elect of any or all of the Allied Societies who may be eligible and apply for admission. (b) By-law 30: The words in the antepenultimate sentence “the said meeting” were altered to “the close of the last General Meeting”

in June"; and in By-law 31, the last sentence, the word "first" was amended to "last."

An ordinary meeting of the Institute immediately followed, Mr. Florence in the chair. The presentation was announced, and acknowledged by thanks, of a framed water-colour drawing representing the stylobate of the temple of Antoninus and Faustina in the Forum at Rome. The picture was executed and given by the Chevalier Settimo Guenpietri, of Rome, a newly-elected hon. associate, and was recently exhibited at the Dudley Gallery.

#### DOMESTIC ARCHITECTURE IN THE EASTERN STATES OF AMERICA.

Mr. A. NISBET PATERSON, M.A., of Glasgow, the holder of the Goodwin Bursary for 1896, read a paper on this subject, illustrated by numerous plans and details, and a few water-colour sketches. The author explained that his remarks would have special reference to questions of plan, construction, heating, and drainage. He reminded his hearers that the first colonists carried with them to America not only the language, the laws, and the flag of the old country, but its architecture also. In what was known as "Old Colonial" would be found reproduced, with such modifications only as ensued from the adoption of wood instead of brick or stone, the buildings of the time of Queen Anne and the first Georges. Influenced, however, by new conditions of climate, of materials, and of class relations, and impelled by a constant and steadily increasing influx of wealth, and demand for comfort, America had produced a type of house characteristic and original. From an artistic point of view, the best examples equalled, if they did not surpass, the highest standard of work in Great Britain; while, as regards convenience and comfort the type was superior to that common in England, and one from which English architects might learn much. Climatic conditions were responsible for the open type of plan characteristic of the American house, and a few of its more distinctive features were elucidated—the cellar for the heating apparatus, which also had an important part in determining the scheme of drainage; the complete system of heating, reducing draughts to a minimum, allowing double doors of extra width to be wide open, and leading to the almost universal adoption of sliding doors; the effect of spaciousness, even in small houses, due to the large hall and open doors; the verandahs, which had greatly developed in suburban and country residences, and became a characteristic feature in plan and elevation; the bedroom "closets," or receptacles for wardrobes, chests of drawers, &c., the heating system rendering the bed-chamber available as a secondary and independent sitting-room or snuggerly, folding beds being largely used; the service-rooms, a marked feature of the American plan, less isolated than in the English houses. Types of town-houses were then referred to in detail, the lecturer selecting examples of the self-contained residence. The houses of the wealthy conform more to the European model, with American characteristics confined to matters of detail. Appreciative reference was made to examples of self-contained residences at Washington, in which the art of planning is admirably exemplified, the awkwardness of the site being turned to advantage, with due regard to the scale, proportion, and symmetry in the disposition of the apartments. Here, too, brick, the material of the country, has been employed in a natural and simple manner, with commendable reticence in design. The lecturer then followed with a description of apartment houses in New York, their appointments, rents, &c.; workmen's houses, with which New York is but poorly provided; suburban houses, dwelling particularly on an example at Brookline, of which a complete set of plans was exhibited; and various types of country houses and summer resorts. In his observations on construction and materials, which were treated at considerable length, the lecturer referred to the

#### STEEL-FRAMED CONSTRUCTION

so largely employed in the tall buildings of the States, as a factor exerting a very pernicious influence on the architects' art from the point of view of sound architecture. Buildings were constructed on the principle of a steel cage, divided horizontally into layers, with no internal supports to speak of, and the whole sheathed with an apparently—but utterly sham—constructional skin of granite, stone, brick, or marble. The stone corbelling under the pro-

jecting oriel, a constantly recurring feature, is, in nine cases out of ten, a sham. Window mullions, themselves probably formed of stone sheathing round a steel core, are carried by steel cantilevers bolted at the back into the girders of the floor below, and the correctly designed and jointed corbel courses with difficulty carry their own weight. The expense of stone—1½d. per cubic foot in New York—was offered as an excuse; yet the same house had its marble, mosaic, and hardwood finishings, at a cost ten times what would have sufficed for making the construction honest. For roofs, floors, and partitions, fireproof construction is now generally adopted in all important domestic work in the cities. The elaborately constructed brick and terracotta arches between the girders, common in England, are not used in the States for floors to be subjected to lighter strains. Floors with tension members are coming much into vogue. In the construction of flat roofs an extensive use is made, in combination with other materials, of "roofing paper" or felt, laid in several thicknesses and bedded in tar. Most commonly the outer skin is of copper, laid either directly on the concrete or on wood and felt, in sheets of 12in. by 24in., and with soldered joints. Partitions are commonly built of hollow blocks of porous terracotta. Tiles of similar type are used for casing structural steel work, and in some cases instead of lathing on the internal wall face. Thin fireproof partitions, finishing from 1½in. to 2½in. in thickness, are much in favour from the saving in space effected. These are mainly constructed by using channel or flat bars, with expanded metal lathing or burlap between, plastered with hard setting mortar on both sides. Particulars having been given of methods of construction in vogue for country and suburban houses, the lecturer discussed the various

#### SYSTEMS OF HEATING

employed, observing that Americans regarded our system of open fires with something of the same feelings as we did the apathy of some of the more outlying countries of Europe and the East concerning modern ideas of sanitation. Nevertheless, the fireplace is as general a feature in American as in English houses, serving as an effectual, and generally the only, ventilator, and valued for its cheerful appearance and the decorative character of its surroundings. Steam, hot water, and hot air are the means of heating mainly employed, the two former being much the same as used in public buildings in England. Warming by hot air, essentially applicable to small areas, and almost unknown here, is practically universal in the States for all houses costing about 6,000d. (£1,200) or less. In the smaller class of city houses, in apartment houses, and hotels where the limitations of space render a multiplicity of air-flues embarrassing or impossible, and where its superior cheapness is of importance, direct radiation, either by steam or hot water, is universally adopted. In the more luxurious and expensive city houses indirect radiation is the invariable system. In the largest mansions the assistance of an electrical or steam-driven fan is invoked to regulate the distribution of the heated air, which is also screened and moistened as required. In treating of these methods of heating, after a brief reference to one or two special forms of installation, the lecturer dealt more fully with the hot-air system as being least known in England, illustrating his description by diagrams of the apparatus, the furnace, cold-air supply, and hot-air flues. In matters of plumbing and drainage, which were next discussed and described in minute detail, the lecturer said America had made great advances of late years, and was now far ahead of England. This progress was mainly due to the stringent laws adopted by the city "boards of health," and rigidly enforced. Before building, a separate and complete set of plans and sections, showing plumber work and drains, to the scale of ¼in. to the foot, had to be deposited with the boards. On these the nature and positions of every fitting, pipe, and trap must be clearly indicated. Draft specifications, some clauses from which the lecturer summarised, are issued by the authorities for the guidance of architects. Two main characteristics are apparent in this class of work—viz., the openness of everything, possibly owing to the cellar system, and the substitution, along with cast iron for freeclay drains, of wrought iron and brass or lead in the supply and smaller waste pipes. The lecturer closed with a description of the "Waring" system of sewage disposal for

isolated houses and small communities, which is employed very generally throughout the Eastern States, and, as he maintained, with entirely satisfactory results.

Professor ROBERT KERR, in proposing a vote of thanks to Mr. Paterson, referred to the great mass of detail which he had brought before them with regard to the internal fittings of American houses. It was fifty years since the speaker visited the United States, but he had kept in touch with the progress in construction that had been going on. American house-planning showed many peculiarities due to the national characteristics, but he confessed he could not see what benefits were to be derived by English architects from its study. The chief differences were due to the love of openness and of display, and of the entirely altered footing on which employers and servants found themselves, a change in social relationship which showed itself in the arrangements of the house. The reception-rooms of many houses in New York displayed a fondness for hotel life; all the reception-rooms were *en suite*, and, in his judgment, the comfort of the house was entirely sacrificed to a love of display. The sliding doors which were substituted for our hinged and folding doors did not conduce to comfort or privacy; the hall was but a rendezvous leading to a string of apartments united by sliding doors, and the bedroom closet was stuffy and musty. The only feature which we could adopt with advantage was the open verandah.

Mr. H. H. STATHAM seconded the vote of thanks, which was carried unanimously and acknowledged by Mr. PATERSON, who remarked that, owing to the equable heating of the rooms, there was not that necessity for closed doors which we experienced, and the average American liked a degree of publicity which would be distasteful to us. The bedroom closet was, in practice, a very convenient arrangement.

#### THE SURVEYORS' INSTITUTION: VISIT TO MANCHESTER.

THE Surveyors' Institution held their first provincial meeting at Manchester on Wednesday and Thursday last, a large number of the members attending, and several distinguished guests also being present. The first day (Wednesday) was devoted to business, and the second to excursions to various places of interest and important works in the neighbourhood. The papers read and discussed at the meeting in the Lord Mayor's Parlour at the Mansion House, Manchester, were Mr. Holden's, Mr. Blashill's, Mr. Hall's, and Mr. Clarke's. In the evening the members and guests, numbering about 140 in all, dined together at the Grand Hotel, Mr. Robert Vigers (senior Vice-President) being in the chair, in the absence of Mr. Christopher Oakley (President), who was prevented by ill-health from being present.

MANCHESTER, 1847 TO 1897.

At the afternoon meeting the first paper read was one on this subject by Mr. John Holden, F.R.I.B.A. (Fellow), Chairman of the Counties Palatine Provincial Committee, and of the Reception Committee organised by the Manchester members of the Institution. Mr. Holden's paper was illustrated by a map, showing, from the Ordnance Survey, the changes and improvements which had taken place in Manchester and Salford during the period covered by his paper. In 1847 these two towns were practically contained within a circle of one mile radius, many of the streets were narrow and crooked, and access from one street to another was by no means convenient. The streets were paved generally with cobble stones, imperfectly set and punned. In some of the principal streets, paved with square sets on a cinder bed, and with the joints filled with cinder, the mud was such as the present generation could hardly imagine. Old half-timbered houses, picturesque but not desirable, abounded, but have now almost disappeared under the stress of improvements. Mr. Holden proceeded to enumerate many of the important improvements, both in the erection of buildings and the widening of thoroughfares, which the last half-century had seen, and especially referred to the changes which had been effected in the railway stations and the approaches to them. What were mere wayside stations in 1847 were now replaced by the magnificent buildings which formed one of the principal features of modern Manchester. From time to time new railway stations were opened,

new public buildings erected, and last improvement of all, the Ship Canal was, after many difficulties, opened in 1894. The result of the great increase of business, and the alterations necessary to meet it, was the removal of many works and mills from the city itself to cheaper land in the outskirts, and the operatives naturally followed in the same direction. The rates in Manchester varied from 4s. 6d. in the £ in 1847 to 6s. 10d. in 1897, and in Salford from 4s. 6d. to 6s. 6d., having been at one time as high as 7s. 5d. The ratable value of Manchester was in 1847 about £640,000, but was now about £1,537,000. The city itself was no longer to any extent residential, the clearing of insanitary areas, the abolition of back-to-back houses, and the closing of cellar dwellings having forced the population outwards. The warehouses had increased in height and stability; hydraulic and electric power, both supplied by the corporation, were superseding the use of steam power, to the great improvement of the sanitary conditions. The old brick sewers had been replaced entirely by glazed pipes. The regulations as to drains were especially strict, all drains inside the area of buildings having to be laid in concrete; but Mr. Holden more than hinted that the "army" of sanitary inspectors had some little difficulty in coping with the "jerry builder" even in Manchester. The great question of the disposal of the sewage was still unsettled. The building regulations had, after many years' persistent urging on the part of the Manchester Society of Architects, been enlarged so far that, from a pamphlet of six pages, they were now expanded to some 134 pages, which Mr. Holden considered a matter for congratulation on the part of the public, although the jerry builder did not see the matter in quite the same light. Manchester seemed, according to the author, to suffer much as London does from the multiplicity of bodies authorised to interfere with the traffic of busy streets, who, having control of water, gas, sewers, telegraphs, telephones, hydraulic power or electric light, arrange carefully to wait until one body of men has taken up and relaid a street, for another body to repeat the process. The parks and open spaces of Manchester and Salford now, said the author, occupy about 727 acres, and the cemeteries about 200 acres; the water reservoirs cover about 860 acres, with a gathering ground of 19,000 acres. The population on an acreage of 13,000 was in 1891 nearly three-quarters of a million. Mr. Holden gave a series of figures showing the great rise in the value of building land in Manchester, varying, of course, in different districts, but all showing a large increase of value.

#### LESSONS FROM FIRE AND PANIC.

By Mr. Thomas Blashill, F.R.I.B.A. (Fellow), superintending architect of the London County Council. Mr. Blashill said that the fact that the destruction of a building by fire was an improbability removed this risk from the class of considerations with which an architect usually dealt. The proportion of buildings destroyed by fire was very low, and under ordinary circumstances the chance was apt to be neglected by occupiers and owners; but when a great calamity happened the public was only too ready to ask why precautions were not taken and to seek a victim, and by the standard then set up, the architect must expect to be judged. It was a question whether, in spite of Building Acts, danger from fire was not increasing among buildings, loftier, closer together, and more densely inhabited. Commercial premises were more densely packed; there was more machinery, timber and other materials were lighter and drier than ever; all arrangements for lighting were productive of new dangers; the proportion of window openings had been much increased, and shutters had been abandoned. The old-fashioned flush window-frame was being brought out again from its reveal, and made in thin casing which would easily catch fire and fall into the street. Lifts going through several stories neutralised the advantage of fire-proof floors, and lighting areas common to different premises did away with the security of party-walls; while unrestricted skylights made ridiculous the provision for incombustible roof covering. In fact, said Mr. Blashill, the most scrupulously legal building of brick or stone might be no more than a kind of grate in which its internal structure and its contents could be most conveniently burned. In the Cripplegate fire the progress was about as rapid, and the destruction over its limited area no less complete, than in the great fire of

1666, and if our methods of extinction had not improved it might have easily rivalled that fatality in extent. The lesson was obvious. We must improve the construction and arrangement of our buildings, even though we went beyond Building Acts. In London, at all events, streets could not be widened, unoccupied areas could not be increased or openings for light reduced. Traders must be left to conduct their business in such a way as to make it possible; and in places of entertainment the numbers of the audience could not be curtailed. All that could be done was to diminish the chances of fire, to check its spread, and arrange for its extinction and the escape of inmates. It was unfortunate that the cause of most fires was unknown. They destroyed the evidence of their origin, and the great lesson was to distrust the safety of any building unless the greatest care was taken in its construction, and not to think that any deficiency could be made up by careful occupation and management. The points most useful to notice were, Mr. Blashill said: (1) the structure and arrangement; (2) legal and other provisions for preventing loss of life in dwelling-houses, in factories, in public buildings, and in theatres and music-halls. The party-wall was generally effectual as a separation between buildings if no illegal openings were made in it, and it would seem that it was most effectual when carried up through the roof. It would be desirable, where streets or areas were narrow, to have fireproof blinds or shutters to openings to prevent the spread of fire inwards or outwards. Every contrivance should be easily closable, and should be closed nightly. The author could not understand the slow progress made in this country in the matter of fireproof floors, which were common in Paris 35 years ago. In the Cripplegate fire there was not a single fireproof floor, though the warehouses had many of them been burnt out at least once. They were wooden floors on iron girders, and the behaviour of iron girders under fire was well known. There were many well-known fireproof floors in which the girders were well incased; but experience taught that great care must be taken that no escape of gas should be possible in the hollows of such floors, or serious explosions would result. In the great rehousing schemes of the London County Council he had taken care to have all the floors fire-resisting. He had used wide-spaced steel joists filled in solid with coke-breeze on which the floor-boards were nailed, and under which the ceilings were plastered. The cost was no more than a good wooden floor, while the thickness was only 7in., saving 2in. or 3in. in the height of each story. He had not heard any complaint as to noise. If wood floors had to be used, the ordinary pugging should, at least, be adopted. Thick joists 2ft. apart and filled in solid with some form of concrete would offer great resistance to fire, coke breeze and cement mixed 4 to 1 being the best. In a great fire the incombustible roof covering, with unlimited dormers and skylights was of little practical use. This might easily be avoided by pugging between rafters or by sheets of asbestos being used on roof boarding instead of felt. There should also be a ceiling of concrete over the topmost story. For partitions, lath and plaster or brick nogging should be avoided. He himself commonly used cement and breeze concrete 2in. in thickness. Very important steps towards making buildings fire-resisting could easily be taken at very little extra cost. The great danger of a staircase usually arose from the cupboard under it, probably stored with combustible materials. If of hard wood, it would resist a small fire for some time; but if it were to be fire-resisting, concrete was better than stone. All hollow places which could contain gas or accumulate inflammable vapour were dangerous. The lining of walls with matchboarding communicated fire at once all over a shop or from floor to floor. The hollows formed by heavy plaster cornices or behind skirtings also transmitted flame and inflammable gas without warning to adjoining or even distant rooms, as shown in several instances which Mr. Blashill quoted. By taking such reasonable precautions as he had indicated, domestic buildings could be made practically safe from fire. One company in London had erected industrial buildings containing some six thousand tenements, and in only one case had a fire spread from one tenement to another. Many attempts had been made to render fire timber fireproof, and had succeeded so far as thin timber went, but he had not found one which would render the mass of a joist or beam fire-resisting throughout. The

matter was well worth further experiment, especially with reference to joinery. Although new buildings might be made fire-resisting, an even more important question at present was that of old buildings. In an ordinary domestic building, if the joists were not strong enough to carry a filling of concrete, they would bear ordinary pugging, and if only a breadth of 3ft. or 4ft. round each floor were filled in, as well as all hollows behind cornices, &c., a considerable amount of fire-resistance would be attained. If also the timber round chimney-stacks were removed, and floors and roofs examined, an old house might be made as fireproof as a new one. Most important of all was the question of saving life from danger by fire, and much legislative attention had been given to the subject; but it was impossible to estimate the mischief which a careless workman could do, and an architect must be careful not to assume that because his plans are for a safe building, it will necessarily be properly built or managed. Mr. Blashill mentioned the case of Cowdray House, in Sussex, which was destroyed by the carelessness of workmen, and gave some of the provisions of the London Building Act of 1894, which were designed to facilitate the escape of the occupants of houses of more than 60ft. in height, that being the greatest height to which a movable fire-escape would reach; but 60ft. was a great height from which to expect women and children, suddenly alarmed and ill-clad, to descend by a ladder in the dark. The ordinary ladders should be replaced by others with flat treads, an easy slope, and handrails, and there should be some protection against falling into areas or skylights. Mr. Blashill preferred the term fire-resisting to fireproof, as did the framers of the London Building Act, for the construction should be such as not to add fuel to the fire, but to resist it for at least a considerable time. By the Factory Act, 1891, every factory, where more than 40 persons are employed, must be provided with means of escape from the upper floors, and the Act of 1895 extends these provisions to workshops and laundries. There should in all cases be a means of access, not to the ground floor of a building, which might itself be on fire, but to some open space where the glow and heat of the fire could be avoided. Many of the victims of the Paris Bazaar fire died in the open yard, which was not large enough to enable them to get away from the heat. In deciding what are adequate precautions, it was necessary to take many circumstances into account; but in the case of factories, as in that of theatres, there should be alternative means of escape at different extremities of the building. The best way of escape, after the staircase, was by the roof, a good flight of stairs being provided to the roof door, which should have an automatic fastening, and by this means many lives were saved in the great Cripplegate fire. There was always, however, the objection that roof doors gave special opportunities to thieves. The Building Act of 1894 made many new provisions for the safety of public buildings generally, which were really a mild adaptation of those which had long been applied to theatres and music-halls. There were many more accidents from alarm in places of worship than was commonly supposed, very inadequate means of exit being generally provided, instances of which the author gave.

#### SOME OF THE DIFFICULTIES MET WITH IN A LAND AGENT'S PRACTICE.

Under the above title, Mr. C. P. Hall (Professional Associate), agent to the Duke of Bedford's estates, read a paper in which he dealt with the points which, in the present depressed condition of agriculture, demanded the especial attention of a land agent in charge of large rural estates. Perhaps, he said, the most frequent of these difficulties was that arising from the question of rent reduction. Many landowners had met their tenants by remissions rather than by permanent reductions of rent; but as the depression continued, it became very difficult to conciliate all the tenants by a uniform remission, and variety of treatment produced discontent. The author's experience was that it was far the most satisfactory plan to reduce all the rents to present value, and, if any further assistance was necessary, to give it in the supply of manure and feeding stuff rather than in money. Again, as assessment committees often refuse to allow for remission of rent, it was often the case that the assessment under Schedule A was actually higher than the rent received, and it was difficult

to induce tenant farmers to appeal against assessments made on them in more prosperous times. The difficulty of obtaining labourers was a growing one, the superior attractions of the towns inducing all the young men to give up what was truly a somewhat dull routine of life in the country. The hours of labour were shorter and the opportunities of amusement greater, and although expenses were higher in the towns, wages were comparatively higher as well; but there was not, as in the case of stock-men, any Sunday-work. Still, the author thought there was a reasonable chance of advancement in life for really intelligent and industrious workers on farms, and as competition in the towns became keener and the rate of rural wages rose—as it inevitably must do—he foresaw some chance of the agricultural population again returning to the soil. The allotment system had been, he thought, overdone, with the result that many labouring men, finding the produce of their allotments unsaleable at a paying price, had abandoned them. Complaints had been made of excessive rental; but a reduction of even 10s. off a £2 rent would not make a success out of an utter failure. Mr. Hall held that the most satisfactory way of carrying out repairs to buildings and fences on a large estate was to employ the workmen direct; but in the case of large new works the contract system was preferable.

#### NOTES ON THE CONSTRUCTION OF TOWN BUILDINGS.

Mr. Howard Chatfield Clarke (Fellow) who was unable to attend, contributed a paper on this subject. He dealt mainly with the planning and construction of buildings, although he recognised the value of attention to architectural features and style. Indeed, he held that one side of an architect's work aided the other. He could not agree with some recent critics that there had of late been a "deterioration in English architecture," but was of opinion that the exact opposite was the case. Architecture in the last 80 years had improved not only in construction, but in design, as the buildings in Manchester amply testified. The requirements of town buildings, such as banks, warehouses, offices, and schools, appeared to him to be—1, ample lighting; 2, simplicity of plan and arrangement; 3, good ventilation and heating; 4, good sanitary arrangements; 5, protection from fire; and 6, the use of suitable materials. On the whole, modern methods of construction met these several requirements to a very large extent, and the warehouse or business premises of to-day, whether in London or Manchester, or in any other great centre of trade, compared favourably with its predecessor in all of the points which he had laid down as essential. The question of protection from fire had been so fully dealt with by Mr. Blashill that there was little left for him to say on the matter, but he might mention that in London architects had found a very considerable number of new regulations on this point, contained in the Building Act of 1894. Buildings under this Act were classed as dwelling-houses, domestic dwellings, public buildings, and buildings of the warehouse class. There were many regulations as to the erection of new buildings on sites previously occupied, which tended, he thought, to the erection of better and more commodious buildings; but this, of course, applied to London only. The height was limited to 80ft., unless the consent of the County Council could be obtained for a greater height, and this was a regulation in the right direction, for excessively high buildings, where the streets were necessarily somewhat narrow, meant draughty, sunless, and cold thoroughfares, detrimental to the general health of the inhabitants of a large town. The provisions of the Act as to the limit of the cubical contents of a building without a fireproof separation from all adjoining buildings were useful, but this point had already been dealt with by Mr. Blashill in his paper. Mr. Chatfield Clarke showed some plans of buildings erected under his supervision in Aldermanbury, London, fitted with fireproof doors which he believed would resist fire as well as the thick brick wall itself. He was not quite sure whether the Manchester By-laws limited the size of individual warehouses, but he would be glad of information on this point. Under the London Building Act, oak and teak, and other hard timber not less than 2in. thick, is allowed for doors and stairs, with 2in. risers and concrete composed of broken bricks, stone chip-pings, or ballast, and lime-cement or calcined gypsum for filling between joists, are deemed to

be fire-resisting. The author referred to the great labour and expense which the Institution had devoted to the perfecting of the London Act, and the valuable services which had been rendered in this direction by Mr. Steward, Mr. Cubitt Nicholls, and Mr. Arthur Garrard (the two last of whom the Institution could unfortunately no longer count among its members). Mr. Clarke proceeded to insist that the only safety lay in sufficient party-walls, carried sufficiently high above the roofs, good iron doors in party-walls where openings were really necessary, the casing of all ironwork in plaster at least  $\frac{1}{2}$ in. thick, high party-walls between adjoining skylights, and external shutters in confined well-holes, and areas overlooked by premises in several occupations. He believed that the best fireproof floor was one composed of five parts of good coke-breeze and one of Portland cement. Mr. Clarke advocated the carrying-up of all windows in town streets into the floor above that on which they were situated, as advantageous for lighting purposes; but we are a little doubtful if Mr. Blashill would consider this advisable from the point of view of fire protection. He confessed that, as regards proper ventilation and warming, architects had still much to learn; but for an ordinary room there was no much better plan than the double-hung sash, with a deep sill-board for the admission of fresh air at the meeting-rail level. Grates fitted with warm-air chambers had worked well, especially in the London Board Schools. Sanitary requirements were now receiving greater attention than ever, and the best of the present systems left little to be desired. Mr. Clarke warmly advocated the increased use in this country of granite as a building material, as the most suitable for town buildings, and gave instances of the cost of various buildings in London, which, he was careful to say, must be taken with some reservation, as the price of labour and materials varied so much that it was difficult to give reliable figures. He gave, as examples:—Warehouses, Thames-street: Brick, wood floors, not plastered, 117,600c.ft., 7d. per cube foot. Schools, Hornsey, London, N.W.: Brick, buff brick internally, glazed brick dados, wood-block floors,  $7\frac{1}{2}$ d. per cube foot. Drapery warehouses, City of London: Fireproof floors, stone front, plastered walls, 1s. 1d. per cube foot. Flats, South Audley-street, London, W.: Stone and terracotta, fireproof floors, electric lift, hardwood finishings, parquet floors, enriched plaster work, 176,000c.ft., 1s. 2d. per cube foot.

#### STAGE MECHANISM.\*

A MOVEMENT known by the name of "stage reform" has of late years received some attention in this country. It originated some twenty years back in Austria, with the primary object of encouraging the greatest possible imitation of nature in the *mise-en-scène* of opera and drama. The rudiments of art, as understood by painters, sculptors, architects, and the cultured public of the day, were to be applied to the stage, and a true scenic art was to take the place of the nondescript, irrational, and frequently coarse mounting previously given to plays. To facilitate the efforts of the scenic artist, the fullest application of our modern sciences (notably of mechanics and hydraulics) in the interest of "stage reform" was considered essential, and the introduction of recent methods of lighting was also deemed necessary. The numerous fatal conflagrations which had originated on the stage caused the question of protection from fire to be closely associated with the movement, while the frequency of dangerous diseases among the members of the dramatic profession preserved the claims of hygiene from neglect. The movement, as I have said, originated in Austria, soon after the terrible "Ring" Theatre fire at Vienna; and, on account of the prominence accorded to protective measures against fire, much headway was at that time made in German-speaking countries. Able exponents were found among leading artists, and stage-managers, architects, engineers, firemen and last, though not least, the Government and municipal authorities, interested themselves in the matter. Since then the movement has not only surely and gradually developed throughout Austria and Germany, but also spread beyond the frontiers of those countries. Concurrently, some quite independent movements also originated

amongst several other nations, and, though the purposes of these were not identical, they were very similar. Throughout Europe a transitional period may be said to have begun for the stage. Up to the present time, however, this period has nowhere attained its desired termination in any generally recognised reform. No definite new era has yet been opened, even in the countries where the movement first obtained a footing. Experiments have been numerous and various, and the failures have almost outnumbered the acknowledged successes. The boldest experiments, with their valuable achievements and costly failures, have, however, now been made, so that little remains to be done except the practical and systematic application of the experience gained. I may here at once say that I see no reason why the experimental or transitional period of the movement should not now be superseded by a new and definite epoch, more especially if the matter is taken up by men who are free from fads of their own. The primary object of the originators of the movement—i.e., the closest possible imitation of nature—has in several instances already been attained; but the art world, and the cultured also, have found that this generally means crude realism. The mystery of the *mise-en-scène*, so necessary to a good scenic picture, is lost, and much also of the so-called "feeling" of the spectacle is lacking. Modern science and the most recent methods have already been employed to some purpose in the interests of the mounting; but stage managers and experts have found that an extreme modernisation of the scenic artist's auxiliaries often means more complication and uncertainty than was formerly the case. The expenditure incurred by extreme reform on the stage has also been found to be disproportionate to the advantages gained therefrom. Both in the effects to be obtained, and in the methods to be adopted, practical reform is now gradually taking the place of radical reform. There can be no doubt that the exponents of the extremist movement have given the necessary impetus towards the improvement of the scenery, and future generations will be greatly indebted to them. As is usually the case, however, with any radical reform, the originators of the movement are scarcely likely to see their proposals adopted in their entirety. Nevertheless, they may be well satisfied that a moderate and practical outcome of their efforts is assured. And this is a great deal when we consider to what an extent the stage clings to tradition and convention, and repudiates any interference from outsiders, and how sweeping the proposed reforms appeared twenty years back. In England, the primary object of "stage reform," the imitation of nature in the *mise-en-scène* of both opera and drama, has certainly found a fair amount of favour. This, however, is virtually due to the manner in which the public have associated the movement with that crude realism which has of late met with so widespread an appreciation in all branches of art and letters. There has been no outcry against the indifferent mounting of a play, and the realism of a spectacle has generally been more appreciated by an audience than its merits as a work of art. "Stage reform" in this country is still associated with the sensational shipwreck, the race, or some other exciting item of the programme, and any popularity of the movement is practically due to the rendering of such realistic scenes. There have not yet been many instances where art alone has helped the movement; but for that matter, perhaps, we have not seen many examples of a *mise-en-scène* on truly art lines. With very few exceptions on a small scale, no extreme reform has been attempted in this country as it has in Austria and Germany. This is largely due to the fact that our actor-managers have to rely on their own purses or on those of some speculative financier, instead of having a certain proportion of public funds placed at their disposal. Our managers cannot afford expensive experiments. Too much risk is involved in the sudden departure from traditions and conventional usages, and the most that can be undertaken is a gradual improvement of the scenery on the old lines. Such improvements, as distinct from extreme reforms, there certainly have been. Sir Henry Irving, of the Lyceum Theatre, is a notable exponent of moderate reform. The late Sir Augustus Harris, our leading *impresario*, also did much in the gradual beautifying of his scenes on recognised lines, though he was frequently hampered by the fact that his productions

\* Read before the Society of Arts, Wednesday, April, 20, 1898, by EDWIN O. SACHS, Architect, author of "Modern Opera Houses and Theatres," &c.

required a too realistic mounting of the ultra-sensational kind. If we wish to see a *mise-en-scène* on art lines, the outcome of, extremist experiments, we have only the private stage at Bushey, where Hubert Herkomer, who at one time took a leading part in the movement in England, has at his own expense achieved numerous successes as a stage-manager and scene-painter. His miniature stage has been a working model from which our actor-managers have learnt much. Those who have had the good fortune to see one of the Bushey performances will have realised the difference between nondescript mounting and really artistic scenery. The general public little knows to what an extent the efforts of Hubert Herkomer have effected stage-management. Without his private experiments it is hardly probable that even Sir Henry Irving's stage would have shown such improvements as are now accepted as a matter of course. The curious feature, however, of the movement in England is not so much the absence of extreme changes in the scenery of our stages, as the almost entire absence of the application of modern science and modern methods in the interests of the stage-management. Even the few exceptions which do exist generally concern only the substitution of electricity for gas in stage lighting, or some minor or mechanical appliances to facilitate what is termed a "quick change." We are, for once, untrue to our national reputation for practical adaptations; and this, moreover, in a case where there is unlimited scope for energetic young engineers. In this country, again, the question of fire protection has not been associated with the movement, and the advancement of stage hygiene seems scarcely to have been considered by our exponents of "stage reform." The former omission is, of course, quite in keeping with our traditions. We insure our property, and never consider the tremendous national loss by fire, nor do we take measures for the protection of life from fire until some great catastrophe has fallen upon us. But in the matter of hygiene, such neglect is unusual in a country which prides itself on its leadership in matters connected with sanitation. I now propose to show how far modern sciences and methods have already been brought into the service of stage-management, and how the protection of audiences and employees has been attended to, so far as the arrangement of stage is concerned. I do not intend to formulate any model code of requirements, or to describe any model stage of my own. This paper will solely indicate examples of stages erected during the last twenty-five years, in which attempts have been made to fulfil modern requirements with the means at our disposal at the end of this great century of technical progress. Earlier examples of stage machinery are not dealt with, as these can easily be explained from what I shall term a typical example of the English stage of to-day. There is little difference between the ordinary London stage of 1897 and the stage of 1700. The electric light may have incidentally taken the place of the lime-light and gas of recent years, or the candles and lamps of an earlier period, and, as I have observed, there may be some "tricky" mechanical detail or slight improvement in the minor gear; but such unimportant contrivances, I am afraid, complete the list of changes made. Even where the *mise-en-scène* is improved so much as at the Lyceum Theatre, the antediluvian wood stage still remains. London, however, is not the only city, nor England the only country, where such lack of progress is observable. Modern stages are as yet rare abroad, except in the countries where "stage reform" originated. The only difference is that, while some of the oldest and worst stages in London have been known to show excellent mounting, good scenery abroad will, as a rule, only be found on a modern stage; and I will here take the opportunity to express my admiration at the perfect scenic arrangement of some of our plays, for the production of which our managers are so greatly hampered by their pitiable stage equipment, which compels them to have recourse to innumerable makeshifts. It would, however, be impossible for the London manager to do such excellent work if he had to change his play-bill daily, as is frequently the case on the Continent. The so-called "set-pieces," for instance, could not then be so extensively used as they are now. It is probable that plays with long runs, in which the stage-carpenter's work becomes mere routine, have partly been the cause of our tardy progress in "stage reform," while the more complicated

requirements of a continually changing play-bill must have assisted the movement abroad. Before going further, I may mention that, with a view of studying modern stage mechanism, I have personally visited most of the theatres on the Continent possessing modern stages. Every facility was granted me by the authorities in every case, so that it is not without a full knowledge of the most recent developments that I have ventured to address you to-night. I must, however, as an architect, claim your indulgence for any errors of expression in dealing with a subject which rightly belongs to the allied profession of the engineer. But, curiously to say, no English engineer seems to have as yet given the stage and its possibilities any special thought. And, what is more, no English stage mechanist nor carpenter has ever given us any publication dealing with the wood stage of old that might serve as a basis for my remarks. I am, therefore, practically broaching an entirely new subject or section in that vast world commonly known as "Technical Science." It would certainly be premature to attempt any rigid form of classification in so new a subject. The exact definition of the headings seems to me practically impossible. It would, however, be well to note that stages may readily be grouped according to the materials of which they are constructed. I will therefore use the main divisions: Wood Stages, Wood-and-Iron Stages, Iron Stages; and will make further subdivisions according to the power chiefly employed in working the appliances. These subsections are: Manual Labour, Hydraulics, Electricity. Owing to the almost entire absence of steam for motive power in connection with stage machinery, a separate division for appliances where steam is employed is not required. I first take the Wood Stage, then the Wood-and-Iron Stage, and, lastly, the Iron Stage. Manual labour is employed in all three, but electricity and hydraulics are only to be found in connection with the latter. Hence, the division of the subject is practically as follows:—  
Wood Stage: Manual Labour. Wood-and-Iron Stage: Manual Labour. Iron Stage: Manual Labour, Hydraulic Power, Electrical Power. Before, however, speaking of the stage, I must particularly call attention to the purposes of the various classes of playhouses for which scenic paraphernalia have to be provided. This may at first sight appear out of place; but I hold that if the purposes of the different institutions are borne in mind, it will greatly facilitate the appreciation of the circumstances which govern the construction and working of stages, and the structural as well as the economic difficulties which have to be overcome. I must also remind you of the necessity for studying the planning of a modern playhouse, more especially in regard to the stage and auditorium, for it should be clearly remembered that stage mechanism is not everything, but that the sighting and acoustic properties have to be considered. The outlines and dimensions naturally depend in the first place on the respective requirements of the stage-management or owner; but in the same way as the lines of the auditorium are essentially governed by the proscenium opening, the setting out of the stage is regulated by the height and width of this all-important feature. Many stages have so-called rear or back-stages, the dimensions of which are, however, dictated mainly by the facilities to be afforded for obtaining certain effects. Altogether I would emphasise that the engineer who wishes to give attention to the subject of stage-construction must fully comprehend the requirements and possibilities, and it is absolutely essential that he should not only know the wishes of an individual client, but also the varied policies or makeshifts necessary under different circumstances, and above all in different countries. In my work "Modern Opera Houses and Theatres," and in various papers read before the Royal Institute of British Architects, the Architectural Association, and elsewhere, I have already spoken of the very different manner in which theatre construction is treated by the architects of the Continent as compared with the way in which it is dealt with in this country. I have laid some stress on what I might almost term the difference of feeling which pervaded theatre architecture, and it would not be out of place to repeat that there exists a considerable distinction between the artist and leader of his profession who is responsible for the Continental buildings, and his more practical *compère* of our own Metropolis. In the same way as there is a decided contrast in the character of those responsible for

the erection of theatres in this country as compared with those on the Continent, so there is a wonderful difference in the *personnel* responsible for the construction and working of the stage. With few exceptions, the construction of our stages is in the hands of a stage-carpenter, who has had no exceptional advantages in the way of technical training, and whose position in the theatre is hardly better than that of any foreman of artisans. Abroad, even for the construction of wood stages, the commissions are given to fully qualified engineers who hold influential positions in their profession. More particularly in German-speaking countries, there is a distinct calling of stage engineering, and though some few of the present leaders may have risen from the ordinary stage-carpenter, this profession is practically now only composed of men whose preliminary training alone often approaches that of our Royal Engineers. The body of stage-engineers includes men with exceptional powers of initiative, as may be judged from the examples of hydraulic and electric stages which I propose to show, and the way in which the work is usually executed also displays, I am glad to say, such full consideration for the requirements of the scenic artist as is seldom found where the interests of art and science clash. In several instances, even, the stage-engineer takes also the position of "director of scenery" (*Artistischer Leiter*), and he is held responsible for all stage effects, including the design of the scenery, which is prepared under his supervision. This last-named combination of offices in one man I certainly do not hold with, and I would add that the arrangement is but rarely successful. I prefer to see the mounting of a play in the hands of a scenic artist of recognised standing, to whom the engineer and the principal of the painting-room should be able lieutenants, and not collaborators on an equal footing. One mind alone should govern the mounting of a play. All the larger theatres of the Continent, it is noticeable, employ permanent engineers, whose appointment is mostly in the gift of the owner, and is held continuously, irrespective of any change in management, lesseeship, or varying appointment of scenic artist. It is not my intention to indicate how much the scope of the engineer depends on the individual in charge of the stage—in other words the stage-manager, lessee, or actor-manager, as the case may be—nor do I wish to speak of the various circumstances on which depends the amount of attention the mounting of a play receives, what effects are attempted, and what methods are employed. All this would lead too far, though, to repeat, it is essential for the theatre engineer to be versed in the varied requirements that he may be called upon to consider. I cannot, however, when speaking of the modern stage, omit some mention of expert opinion on scenic art and its auxiliaries, for nothing has so materially influenced the recent development of stage mechanism as the candid criticism of recognised authorities. In the first place, let us look at the question purely from the artist's point of view. The distinguished artist Hubert Herkomer, holds "that the real secret of perfect scenic art lies in illusion"—i.e., in visual deception—or in not allowing the eye of the spectator to discern the means whereby the semblance of reality is obtained. Mere actuality will not accomplish this any more than good painting *per se*. It is in the attempt to get absolutely every requisite effect by painting that so much mystery is lost on the stage, for the scenic artist's art should be as much concealed as that of the actor. It should not be too manifest whether a background is painted or modelled, any more than that an actor is "made up" or appears in his natural form. Let us remember that an actor whose wig, for instance, is so badly fitted that his own hair is visible would not be tolerated for a moment; and yet the public will accept a street scene painted on a canvas that is moved by every draught, a rose-bush cut out of thin boards, or a moon rising very quickly straight up the sky and then remaining stationary. Do not forget that it is quite safe to let down a wobbly sheet of canvas close to the footlights, with a scene painted thereon representing breakers dashing over the rocks, and perhaps a sinking ship in the distance to which the actor may have to refer in his speech. It is safe to have layers of canvas hanging from the "sky" like so much washing hung on a line, and certainly but few have ever questioned the prerogative of the "firmament" to come together

at right angles in the corner. Why, it would take almost a volume to describe the many anomalies of scenery constantly observed on the London stage. Again, from the stage-engineer's point of view, authorities abroad have published opinions which are not so very unlike Herkomer's. They assume that the desire for realism which pervades the 19th century has completely changed the ends and aims of modern scenic art. The decorative artist, like the actor, must know how to be in earnest. Actor and scene-painter alike must, above all, so labour that the audience shall forget that they are within the four walls of a theatre. But our old stage methods prevent the realising of such an aim, and the impression of an audience that they are only witnessing a play is often far too palpable. Why have the horizon cut horizontally to a crease, showing where the cloth has to be canted? Why let our beautifully painted panoramic scenes jerk along according to the jerky manner in which the scene-shifter handles his drums? The panoramic scenes may cost £1,000, and yet the simplest mechanical contrivance to insure their smooth working is grudged, and the effect entirely spoiled. Surely, gentlemen, this is not as it should be. Does it not seem curious that in these enlightened times the theatre should still have to develop behind the back of society, and that the memory of the former condition of things still clings to matters theatrical? Truly the actor of to-day is treated well enough by society: he is no longer a vagabond and a stroller. Nevertheless, the stage still occupies an exceptional position; it is still to a large extent ignored by the State and by Science. Let us look at the matter even from the most prosaic point of view—its commercial aspect. Science has turned industrial. She tins meat and condenses milk. But she has not troubled herself about the stage. We employ the same wasteful methods as if modern science were non-existent. Surely it is time to wake up to the necessities of modern entertainment! A large number of drawings, photographs, and sketches of stages were here shown as limelight views, and these were explained and criticised by Mr. Sachs. Reference was also made to a collection of drawings exhibited in the lecture-room. Among the stages of which illustrations were shown were the following:—A Typical Wood Stage, Drury Lane, Covent Garden, Her Majesty's, Court Theatre, Dresden; Court Opera House, Vienna; National Opera House, Paris; Municipal Theatre, Rotterdam; Palace Theatre, London; Court Theatre, Schwerin; Municipal Theatre, Amsterdam; National Theatre, Christiania; the "Asphaleia" system; Municipal Theatre, Halle; National Opera House, Buda Pest; Hofburg Theatre, Vienna; Court Theatre, Berlin; Court Opera House, Munich; special appliances at Drury Lane.

#### AMALGAMATED SOCIETY OF CARPENTERS AND JOINERS.

THE annual report of this society has been prepared and issued from the general office in Manchester by Mr. F. Chandler, the general secretary. The society has 735 branches, 32 having been opened during the year and six closed. There are 38 branches in the United States, eight in Canada, seven in New Zealand, 28 in Australia, and eight in South Africa, the remainder being in the United Kingdom. The new members enrolled in 1897 numbered 9,270, the exclusions 4,418, and the total membership at the close of the year was 53,057, an increase during the year of 4,426. The receipts for the year were £137,238 10s., which included £10,793 raised by levies in support of the society and other trade unions. The disbursements were £106,886 4s. 8d., and the cash balance at the close of the year amounted to £136,308 10s. 8d., an increase for the year of £30,352 5s. 3d. The disbursements included sums for unemployed benefit, tool benefit, sick and accident benefit, burial of members and their wives, and for aged members' superannuation. As regards the expenditure on "trade privileges," the following remarks are made:—"This branch of our expenditure is one that is watched with deep interest by our critics, as it represents strike-pay and the maintenance of the privileges of our trade (called by some the 'war-chest'); but out of an expenditure of upwards of £106,886 we have only needed for our ordinary section a sum of £5,807 10s. 2d., or an average of 2s. 4½d. per member, which is £6,077 less than 1896 and the lowest amount expended since the year 1889.

This satisfactory reduction cannot be attributed to the fact that we have not improved the condition of our members; on the other hand, the formidable list of places where wages have been advanced shows our activity in this direction. But employers have shown a more willing disposition to concede the right of our members to participate in the benefit of good trade, and there has been also a willingness on our part to be guided by reason and moderation in making demands." The recent dispute in the engineering trade is alluded to, and it is pointed out that, although the interests of the society are "closely allied with engineering operations, the society has passed through the ordeal almost unscathed. What the society has to learn from that great struggle is that federation is a success when formed and matured on the lines of resistance in one exclusive industry. It is reasonable to assume that the same principle properly worked out would tell in favour of labour; but we have not yet such reliable evidence that employers can so harmonise their conflicting interests as to be able to form a federation of a variety of trades for a similar purpose. Therefore, pending the settlement of the question of a general federation of trade unions, our duty clearly is to urge forward and persevere in establishing more complete unity amongst what is known as the building trades, so that in the event of history repeating itself by substituting building trades for engineering trades, we shall then be prepared to meet it in one solid phalanx, instead of our strength being frittered away in sectional attempts to deal with an organised body of capitalists."

#### SANITATION AND THE FINE ARTS.

IN connection with the Royal Society of British Artists, Sir Wyke Bayliss (president), on Saturday, gave an address in the large gallery of the society, upon the duty of the dwellers in great cities in respect to the nurture of the fine arts. The address was entitled "Art in the House of Her Friends." Having suggested, in explanation of this title, that if art had any friends anywhere, they were to be found amongst the dwellers in great cities, the president pointed to the connection between the work of the artist and the work of the sanitary engineer. What, he asked, was art but the science of beauty, and what was sanitation but the science of health? Health and beauty were almost synonyms. Where there was perfect health there was beauty, and where there was perfect beauty there was health. If health was the foundation of the Temple of Beauty, beauty was the shrine of the Temple of Health. Unfortunately, this intimate relation between health and beauty was not popularly understood. It was not, for instance, realised that the advance of architecture was seriously hindered by the insanitary condition of our great cities. Dirt stopped the way of all the splendid developments of decoration by virtue of which architecture took rank amongst the fine arts. He asked his audience to think what the façade of a public building might be but for the all-pervading, ever-increasing plague of atmospheric dirt. They need not go back in imagination to the times when their forefathers saw the splendours of Westminster Abbey, its delicate tracery, its shafts of marble, its wealth of statuary, long since lost to them in the veil of black slime that covered everything in London. Cathedrals in purer air—Lincoln, Winchester, Ely, or Salisbury—still showed what magic could be wrought by the wizards they called architects. But in London the air was thick with smoke. People passed and repassed, and knew not that the grimy objects that filled the niches of the abbey were amongst the loveliest of the sculptures that the world had ever seen. This showed how much we lost of the work accomplished by the great architects of the past. But the limitation on the efforts to create new forms of beauty by the introduction of colour was also to be considered. The resources of the lapidary and of the worker in mosaic were lost to these architects because of the foulness of their atmosphere—a foulness not inherent to it, but made by the populace in the innocent process of cooking their mutton chops. The fault was not to be charged to their climate. Milan was amidst the plains of Lombardy; Rome was within the reach of the miasmas of the Campagna; Genoa, Pisa, and Venice were wet with the salt mists of the sea. No, it was not the climate they in London had to fight against, but the climate plus dirt. It was the climate in unholy alliance with the guerrilla

contingents of smoke and foul gases that decimated their forces, and carried foolishness into the councils of their building committees. He asked, Were they ever going to clarify the air of London, and Liverpool, and Manchester, and the other dark places of the earth? If it was true of the dark places of the earth that they were full of the habitations of cruelty, it was also true that they were full of the habitations of ugliness. Were they going to give the artist that which he valued as his life—that without which life itself was of no use to him—light? If they would enable the artist to "see" their great cities, he could promise that art would make them beautiful to look upon. Passing from the subject of their enemy, the chimney, the president glanced at the importance of the gutter as an aid to the cleanliness of streets and buildings, and incidentally pointed out that the appliances necessary for the sanitation of buildings were not irreconcilable with the laws of beauty. The aims of the sanitary engineer fell in with the aims of the architect; the gargoyle, primarily a gutter, was often shaped to add beauty to the fabric. The gargoyle was essentially the work of the architect, but it introduced the sculptor into the game. The reference to the sculptor brought the president to another branch of his subject. What, he asked, had become of the few works of sculpture that were supposed to adorn London? Did they not look as if they had suffered martyrdom at the hands of the gamins of the streets on the 5th of November? They were absolutely black with slime. Was that the best thing that could be done with them? The sculptor cried for help. Who would save him and his work from destruction? The president next alluded to the effects of the "tenebrous pall" of their cities on painting. Any great scheme for the development of national and historic painting in England was hopeless so long as the present state of things continued. England had taken a high position in the history of art. There had been two great periods of art—the Classic, which gave them the Parthenon, and the Gothic, which gave them Westminster Abbey. The mastery in these two schools, each perfect in itself and neither second to the other, belonged to the people of Greece and to the people of England. The race of men who built their cathedrals were equal in artistic capacity to the race of men who built the Acropolis of Athens. They, then, as Englishmen, had a past to build upon, and ought to have a hope for the future. A pressing question, however, was the establishment of right conditions. This was a question which the nation must answer through the medium of the sanitary reformer. He was confident that if this question were rightly answered, art would make the nation a rich return. After all was said and done, art was, and always must be, one of the environments of their lives, perpetually shaping them to fair or foul issues. Bad art meant much more than bad artists. It meant dreary surroundings in their dwellings, ignoble buildings in their streets, evil thoughts in their hearts. The converse of this, however, was true as regarded good art, and he earnestly appealed to his hearers to do all they could to assist in the removal of the obstacles which he had indicated as existing in the path of the artist, who should aspire to do noble and imperishable work.

#### A CHAPTER IN THE HISTORY OF POTTERY.\*

THIS is the title of a descriptive account of the Twyford pottery industry. The Twyford date, it is said, from the earliest period of Staffordshire pottery, even before the Wedgwoods. Mr. Thomas William Twyford met the requirements of the domestic engineer and architect with a true insight into the demands of the future, and the "chapter," which has been so pleasantly written by Mr. Joseph Hutton, illustrated by 25 photo. views of the various workshops and processes, will be welcomed by all who are interested in this important manufacture and its various developments. The iron and pottery district of Staffordshire has well been called the "backbone of England," and the Cliffe Vale Potteries of Twyford holds a unique position among establishments. Mr. Hutton writes: "One need not be an artist to appreciate the sense of form and proportion which Mr. Twyford has imported into the architecture of his new

\* Twyford's: A Chapter in the History of Pottery. By JOSEPH HUTTON. London: J. Virtue and Co., Ltd., Ivy-lane.

kilns, that are an agreeable contrast to the haphazard and bulbous fashion of the ovens of the old school of pottery, with its ill-regulated shops and its disregard of the sanitary laws of health." In the plan and construction of those works every building and detail was arranged by Mr. Twyford. All the floors are of concrete, to prevent the heat of the lower stoves rising to the floors above; all walls between work-shops and stove are of brick for the same reason; each man has a window to himself, and every care has been taken to make Cliffe Vale a typical example of the application of the laws of health. We can only briefly refer to the book before us. Mr. Hatton sketches the history of pottery from the red ware of Egypt to the Italian faience. The history of this particular pottery from the Elers Brothers, who first developed the manufacture of Staffordshire earthenware, followed up by Astbury and Twyford, who manufactured red porcelain and white pottery glazed with salt is interesting. Some very beautiful early Twyford teapots in the Hanley Museum are shown. The views illustrated begin with the Cliffe Vale Potteries, an important range of buildings, the fireclay bath-makers at work in their shop; next the fireclay lavatory makers, the fireclay kilns; potters making "Twycliffes." Then follow in succession views of the fireclay shop, the canal, the mill-house, the "slip"-house, model makers, the biscuit ovens and warehouse, printing shop, dipping house (in both of which women are employed), glost ovens, gilding and decorating shop, glost warehouse, &c. These represent sanitary workshops, for sanitary-ware is the great development at Cliffe Vale. Our readers all know the many types of basins, such as those of the "pedestal" class. Twyford's "Unitas" was the pioneer of the "Pedestal closet," a most important departure. It was exhibited at the Health Exhibition in 1886. The "wash-down" was next introduced, as illustrated by the "Deluge" pattern, one of the most perfect of its type. In 1894 the "Twycliffe" was introduced, a perfect basin that has never been surpassed, that is meant to supersede the "wash-out" and "wash-down" principles. Mr. Hatton's narrative deals with every process of the manufacture, and this part of his work is instructive and interesting. Our readers will find much that is of general concern in this book.

#### LIVERPOOL LANDING-STAGE EXTENSION.

AT the meeting, on Monday night, of the Liverpool Engineering Society, Mr. John A. Brodie, city engineer, in the chair, Mr. Hugh Rogers, assistant to Mr. A. G. Lyster, the engineer-in-chief to the Mersey Dock Estate, read a paper on "Liverpool Landing-Stage Extension and Prince's Jetty." He explained that in extending the Prince's Stage to the northward, provision had to be made for landing cattle and cargo. Four decks had been provided, each with runways for cattle and stairs for the passengers, leading to the street level. The total length of the jetty was 400ft., and 67ft. wide. The main timbers of the structure were all greenheart, the uprights being 14in. square, and varying in length from 47ft. to 76ft. 8in. The cross-braces were 12in. by 6in., and the diagonal bracings 12in. by 12in. The joists of the deck were all of creosoted pitch-pine, and the deck was of greenheart, 3in. by 4in., spaced  $\frac{1}{2}$ in. apart. At this point of the river the bed was of red sandstone rock of a hard, close nature, varying in depth from about 12ft. below old dock sill at the river wall to about 40ft. below the old dock sill on the face line of the stage. Along the river wall, and for a width of about 50ft., a bank of stones, boulders, and the like, had evidently been tipped, probably to protect the toe of the wall. The tide at this point was very strong, which had proved a serious point to be considered in the method to be adopted of obtaining a suitable foundation. The ordinary system of tide-work dams would have been most expensive, both on account of the tide and the depth of water, and also on account of the river traffic at this point. Screw piles were also considered, but as this entailed boring and blasting in order to get a hold for the piles, this system was given up. Mr. Lister finally decided to adopt some form of drill with which to form pockets in the rock, and then to grout the uprights into these pockets with concrete. It was also decided to form a hole large

enough to take the pile itself, instead of trusting to the straps of the pile-shoe only, as in the case at Newcastle. For this purpose a drill was obtained which was capable of drilling a hole 25in. in diameter. After a trial of several months it was decided to abandon this drill and adopt other methods. Such a drill proved unsuitable for the rough work that it had to face, besides being a very expensive tool, both as to first cost and also for working. The next method adopted, and one which proved most successful, was jumping the holes down with chisels. The design of chisel finally adopted was a flat blade of wrought iron, with a cutting edge of steel about 6in. up, and fitted with detachable wings. The centre portion of this chisel was cut away for a width of 8 $\frac{1}{2}$ in., and about 18in. high, making the cutting surface 15 $\frac{1}{2}$ in., thus reducing very considerably the vibration caused by the blow, and the small core which was left standing was soon broken off with the jar of the blow. This chisel weighed about 10cwt., and was connected up with boring rods of different thicknesses, the lower rods having guides fitted to them for working in the centre of the pipes, and to prevent vibration as far as possible. This system did away with the time occupied in screwing down the pipes, as in the case of the diamond drill, for the pipes always followed the chisels down until the rock was hard enough not to fray away with the jar of the blow. As regarded the extension of the floating stage, the design of this length of 400ft. was practically the same as the old Prince's Stage, only slight alterations being made in the details. The new portion was carried by 27 pontoons, 23 of which were 80ft. long, by 10ft. wide, and 5ft. deep, the remaining four being 96ft. long, this extra length being provided to carry the foot of the bridge connecting the stage and jetty. These pontoons ran transversely to the stage, and carried the kelsons, which ran longitudinally. These kelsons were box girders composed of iron plates and angles, and were 4ft. 6in. in height, and across these again were the deck beams, also of iron. The pontoons were put together in Birkenhead. They were tested for tightness by being first filled with water, and afterwards by the external water pressure due to their own weight. Each pontoon had three watertight bulkheads. When completed the whole was towed across to Liverpool and put into position, and the connections with the old kelsons riveted up. As an experiment, and for a better foothold for horses, a strip 30ft. wide for the full length was laid with end-on blocks of creosoted pitch-pine, 3in. wide and 3in. deep, the joints being run with pitch and fine gravel. The bridge connecting the stage and jetty was erected on the north end of the stage, and when completed was launched into position. The bearing for this bridge on the jetty was composed of a steel axle working on a cast-iron pivot and cast-iron bearing block, the stage bearing being two half-round cast-iron shoes working on cast-iron slides. The length of this bridge was 152ft. by 21ft. wide over all. The total length of the Liverpool Landing-stage was now 2,463ft., and the normal width 81ft. 4in., having a deck area of 23,098 square yards, or 4 $\frac{1}{4}$  acres. The whole stage was floated on 180 pontoons, varying in length from 60ft. to 120ft. It was approached by eight bridges, and kept in position by seven booms and 29 mooring chains (14 ebb chains and 15 flood chains). In addition to the seven bridges, there was a floating roadway 550ft. in length and 35ft. in width.

#### "LINCOLN CATHEDRAL," BY PETER DE WINT.

[WITH PHOTOLITHOGRAPHIC ILLUSTRATIONS.]

THE de Wints were Dutchmen, and Peter the Painter was descended from a wealthy merchant of Amsterdam. His grandfather left the sleepy canals and slow counting-houses of Holland, and settled in New York, where the painter's father, Henry de Wint, was born. The elder de Wint, a merchant of ample means, sent his son to Leyden to study physic, and thence to London to take his degree. This having been accomplished, the doctor when he was 21 married an English lady of good family, but no means. As a result of this alliance, his rich parent withdrew his allowance, and left all his wealth to the eldest son. Dr. Henry de Wint, thus cut off without money, settled in Staffordshire, and gradually obtained a practice. Peter de Wint was his fourth

son, and was born on January 21, 1784. The study of surgery ill-accorded with the artist's tastes, and therefore he was placed in 1802 with the engraver John Raphael Smith. Here he met the future Royal Academician and historical painter William Hilton, and a friendship was formed by the two lads that ended only in their death. About 1807 both pupils entered as students of the Royal Academy during the keepership of Fuseli. In 1810 de Wint first became an exhibitor, sending in two water-colours from Staffordshire, and one a view in the neighbouring county of Derbyshire. De Wint visited Hilton's home at Lincoln, where he found numberless subjects for his pencil, some of his best pictures being those of the noble cathedral there. De Wint found here, too, his wife, for he married Hilton's sister in 1810. This same year de Wint became an exhibitor with the Society of Water-Colour Painters, and eventually a member of that body, in whose exhibitions for 40 years his productions were to be seen. In nearly all his works breadth of handling in flat-washes gave great freshness and purity of colour. His art was neither realistic nor ideal; but he had a fine sense of colour, and truly appreciated the tints and harmonies of natural scenery. His figures are well placed, but individually look clumsy and feeble in their forms. They are, however, effective as to light and shade, leading the eye into the picture, and enhancing points of colour. De Wint died of heart-disease in 1849, and lies buried near his friend and brother-in-law in the ground of the Chapel Royal in the Savoy. In Lincoln Cathedral a handsome altar-tomb to the two friends, who loved each other in life and in death were not divided, was erected by Mrs. de Wint in memory of her husband and brother. The Exchequer Gate, which forms so charming and conspicuous a feature in the grouping of the Cathedral precincts at Lincoln, has been thought by some writers to be unfortunately located, inasmuch as it prevents an uninterrupted view of the west front of this magnificent minster unless a bird's-eye is obtained from the Castle, such as that which we published from the brush of Frederick Mackenzie, the distinguished architectural draughtsman (b. 1787, d. 1854) in the BUILDING NEWS for March 6, 1896. Another view from the same eminent standpoint will be found drawn by Mr. Charles H. Holden in our pages for Sept. 21, 1894; but in this case the view is shown looking more towards the S.W. of the church, whereas Mackenzie's grander view takes in the Chapter-house and the N.W. side of the picture. To-day, the drawing which we have chosen has been reproduced specially for us from Peter de Wint's original water colour, now in the National Collection at South Kensington Museum. It represents Lincoln Cathedral, almost as it were in true elevation, and thus the Exchequer Gate is seen coming right across the road, and forming, as it does, the entrance to the Close. Whether this so-called obstruction may be considered rightly a disadvantage or not, must remain a matter of opinion. Anyhow, de Wint's delightful study emphasises the charm resulting from the fact that all the west front is not displayed to view at once. Besides the above-named illustrations of Lincoln Cathedral, it may be useful to mention some others which will be found in the BUILDING NEWS of the following dates:—General plan of minster and secular canons' buildings (by the late Mackenzie E. C. Walcott), February 8, 1878; plans of Cathedral, April 2, 1869, and February 6, 1891; Galilee porch and west front (W. H. Bidlake), November 26, 1886; Galilee porch and central tower from south-west (C. E. Mallows), February 6, 1891; rear of west façade from south-east, June 21, 1889; central tower and south-west transept (C. H. Holden), October 5, 1894; south porch (W. H. Wood), February 28, 1879; general view from south-east (Axel H. Haig), April 2, 1869; east end (C. H. Moore), March 31, 1890; cloister and north transept (W. H. Bidlake), February 6, 1891; north door to choir (John Begg), February 6, 1891; chapter-house (H. Harrington), October 19, 1883; Angel choir, interior (pencil sketch, by John Begg), February 6, 1891 (ditto from photograph), May 24, 1889; bay of choir (Sydney Vacher), February 27, 1880; Angel in choir (J. P. Seddon), December 24, 1869; bosses from Angel choir (T. Fred Pennington), June 21, 1878; chancel gates (W. H. Lethaby), February 27, 1880; door of north choir transept, December 24, 1869; interior of north-west chapel (the late Sir G. Gilbert Scott), February 6, 1885; Bishop Russell's tomb in choir (measured drawing,

by Francis Hooper), April 7, 1882; Bishop Wordsworth's tomb [by Bodley and Garner] in retro-choir (from photograph), May 18, 1888; monument to Richard of Gainsborough, architect of Angel choir, in south walk of cloisters, September 7, 1894; details of staircase in cloisters (measured drawing, by J. Hutchings), October 26, 1888; miserères (T. F. Pennington), April 23, 1880; bay of nave, October 23, 1885; eagle lectern (W. H. Bidlake), April 30, 1886; stone arcading (measured drawing, by H. G. Gamble), November 25, 1887; stone beam between west towers, October 23, 1887; 12th century window, November 29, 1878; and 13th-century mouldings, August 25, 1871.

#### THE DOME OF THE CITY HALL, PHILADELPHIA.

**A**N instructive and well-illustrated paper by Mr. Francis Schumann, on the "Metal Dome of the City Hall Tower, Philadelphia," appears in the *Proceedings of the Engineers' Club* of that city. Mr. Schumann gives an account of the construction and execution of this tower, which was designed by the late John McArthur, architect of the Public Buildings at Philadelphia, and carried out under Mr. Schumann's superintendence. The work was begun in 1890, and was completed in January, 1893. We give an illustration of this tower some time since, showing the iron framing. The two upper stages have isolated columns in pairs. From the upper stage with segmental pediments, over the clock-dials on the four faces, springs the cupola, an elongated dome of octagon shape, crowned by a colossal statue of Penn. The height of the tower from the ground is 337ft. 4½in. It is of brick, faced with marble, about 70ft. square externally, and about 45ft. internally. The tower is enriched by several stages, cornices, balconies, and other ornamental details. Upon this tower of masonry the metal dome rises a further height of 210ft. 9in., making a total to top of statue of 548ft. 1½in., an altitude which exceeds most of the great historic examples of this country or America. A few details are given that may be of interest. The total estimated weight of tower extending 15ft. below the ground to top of concrete foundations is 62,768 tons; the concrete is 8½ft. thick, and covers an area of 7,160sq.ft., and weighs 4,000 tons. For a height of 90ft. the tower is attached to the north wing of building, and is bonded to it. The upper clock story, which rises 60ft. into the dome, has a clock dial on each face 23ft. in diameter, and to the centre of dials it is 36ft. 3in. above the ground level. The dome has a slight curve, and is enriched by angle ribs, cornices, dormers, and festoons. About 145ft. above the masonry of tower the floor of balcony is reached, the highest part accessible by means of stairs and elevators, and from it the top of the Penn statue is 65ft. 10in. By means of ladders through the "tree stump," which forms a central support to the statue, the visitor may enter into the body of the figure itself, and may also put his head through the crown of Penn's hat. The four pediments of the tower below is surmounted by bronze eagles, and allegorical bronze groups represent the four epochs in the early history of Pennsylvania. The shell of dome is electro-plated cast iron, the louvered panels being of sheet steel.

Describing the structural part of dome, which is of wrought iron and steel, the form is an octagonal prism to the height of clock-story, the remainder an octagonal pyramid ending with the steel apex cap supporting the stone. The octagon is formed of meridional columns or chords at the corners, and these are supported on four box girders, placed diagonally across the masonry tower, bedded in cast-iron plates about one-third of the length of girder. This brings the weight of dome through the columns to the clear ends of the girders, which act as cantilevers, thence to the solid portions of masonry, thus clearing the window-openings. These girders are bolted to the masonry by two 3in. diameter anchor-rods to each girder. The rods extend down 70ft. to anchor-plates imbedded in wall. The columns are braced together by horizontal struts dividing the dome into ten tiers of bays, each panel intersected by diagonal tie rods, these made to resist both tension and compression on the upper tiers. The apex cap of steel is an octagonal tube of steel plates and angles, upon which the statue is bolted. The author describes the several floors which divide the dome. There are four floors perforated for stair and elevator. Considerable skill has been shown in the iron framing

supporting the 24-foot statues at the corners. The segmental pediments, bronze group parts, and the details are illustrated by several drawings of sections of the framing, reproduced by photographic means and by views of the progress of work. The colossal figure of Penn and diagrams of strains are shown also on several sheets, and the dimensions and weight of the framework are given. The paper is a valuable contribution to the literature of structural ironwork of this description.

#### WROUGHT STEEL PIPE-CLIPS.

**M**ESSRS. CHARLES WINN AND CO., of Birmingham, are making bright tinned pipe-clips, which will be found light and strong.

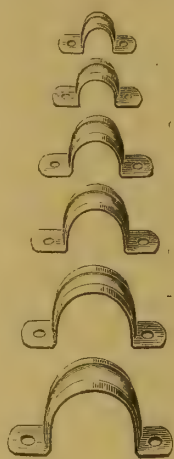

They are turned out in wrought steel, and are quite a novelty, and will, we think, speedily take the place of the cumbersome and more expensive means of fixing lead and other pipes at present in use.

#### THE SCALING OF PAINT.

**I**N a previous article the causation of blisters in paint on woodwork has been fully considered; in the present article it is proposed to point out the cause of paint scaling off from the surface of wood, iron, plaster, &c. Let us first consider the scaling of paint from wood. Besides the cause mentioned in the article above referred to—viz., the elimination of glycerine from the oil vehicle in the paint; there is another frequent cause of water blisters forming beneath a coat of paint that is laid on woodwork. This water may owe its origin to several causes:—(a) it may be the natural sap inherently present in green wood (i.e., wood not sufficiently dried before working); (b) it may be due to the water being absorbed from external causes into the pores by the wood itself; as, for instance, the ends of the woodwork—which are seldom painted over—may be brought into close contact with some damp material, whereby the water is absorbed in the pores of the wood by capillary attraction. Take, for example, the case of skirting boards or the boarding of a wooden partition. Only the face of the skirting-boards receives a coat of paint. The bottom edge is left entirely unprotected, and so likewise are the ends of the skirting. Now, both bottom edge and ends may rest directly against damp brickwork or bricks or tiles which are of a porous quality. Consequently, water will be readily imbibed by such wood. (A great mistake is made in not painting both ends and edges of skirting-boards.) (c) Water may also have been absorbed by the wood through its exterior surface owing to accidentally becoming wet, and the water having been driven into the interior of the wood by it being subjected to heat, such as the sun's rays or the heat of a fire in a room. From whatever cause the presence of water may be due, it will prove fatal to the permanent adherence of any coat of paint. For this reason, when such painted wood is subjected to the sun's rays or any other source of heat, the water present in the woody fibre will be gathered up into large patches, according to its freedom of traversing the fibre of the wood. The fibre around "knots," &c., in wood is always denser and harder than other parts, and consequently prevents a free travelling of the watery particles. These large accumulations of water will be drawn to the surface of the wood;

but as they cannot escape through the hard skin of paint, they will press the paint away from the wood, or from the primary coat, and cause it to bulge up in large patches. When the source of heat diminishes in temperature, the water will be reabsorbed into the woody fibre; but the bulged-up paint will remain, and in time become dry and brittle—so brittle, in fact, that the slightest jar will cause it to scale off the wood. If the under-side (that side which has been next to the woodwork) be closely examined, it will be noticed that it has a rough surface. Such rugosity affords evidence of the tenacity with which it has clung to the wood itself—showing, in fact, that the paint skin has been forced away from the wood by a great pressure, the surface of the paint, in fact, conforming to the rugosity of the wood's surface. When we remember that paint which has been exposed for an hour or two under a severe sun is so hot as to scarcely bear touching with the hand, we can understand that any water which has been gathered beneath such paint will have been converted into steam, or, at least, made so hot as to exert a considerable expansive force. If the water-blisters are due to the excessive amount of water that has been imbibed by the wood, but which has not been subjected to excessive temperature, then the paint will be rendered non-adherent to the woodwork by the presence of the excessive water in the pores of the wood: consequently the paint will not be bulged up, but will lie flat. As the water is dried out of the wood in the course of time, the skin of paint will dry and harden, but be non-adherent to the wood, until at last it is so brittle that it will not bear its own weight, but flake off at the slightest touch.

In the article already referred to, it was pointed out how very unprotective the primary coat is. Such a thin coat of red-lead, turps, and oil as is usually applied is not sufficiently thick to prevent the water penetrating it, and reaching the second coat of paint; consequently the underneath side of the scales of paint will show where they have been riven from the priming coat. In some few cases it will be noticed that the under side of the flaked-off paint carries the priming coat also. Such is due to the primary coat having been too thick to be penetrated by the water, and consequently the priming coat has been dislodged from adherence to the wood fibre, owing to the aqueous particles present in the wood. A suggested remedy is to saturate the pores of the wood with a spirituous solution of wax of some sort, so as to fill the woody fibre with a waterproof substance whereby the interstices in the wood fibre cannot hold watery particles. Such a spirituous solution could be made by dissolving stearine or paraffin wax in benzine, and applying same to the wood before laying on the priming coat. The wood should be then subjected to a source of heat sufficiently strong to drive the wax into the fibre, but not entirely away from the surface. A skin of wax on the wood surface that was sufficiently thin to permit the paint coming in close contact with the woody fibre would be a good preventive of the formation of watery blisters under the paint. But, unfortunately, even this remedy would not be permanent if the painted wood were subjected to the fierce heat of the sun or a stove-fire, for the wax would be either driven too far into the heart of the wood or else driven up under the skin of paint, and consequently such wax would form a buffer between the wood and paint, that would not permit the paint to adhere to the wood. Another remedy would be to paint the wood before placing it *in situ*, particularly the ends, so as to prevent the absorption of water from extraneous sources.

The scaling of paint from iron is due to the formation of rust on the surface of the iron, such rust being engendered by the penetration of moisture through the coat of paint while still moist, or else by the elimination of the glycerine from the oil-vehicle in the paint, as already pointed out in the article above referred to. The rusting of the iron may have been started before it was painted; and if so, the rusting process will proceed, and progress over the metallic surface until it spreads all under the paint, and separates the same from the iron.

The remedy is obvious—viz., carefully scrutinise the surface of the iron before proceeding to paint it, and if there be the slightest appearance of rust, if only in spots, carefully scrape such parts of the metal until the grey iron beneath is exposed; then immediately lay on a coat of paint—red oxide of lead, or else a solution of paraffin



wax in benzine—a very thin solution, so as not to put too thick a skin of wax on the iron, or the paint will not adhere. If the metal is at all scaly, rust may be present under such scales; it will be best then to "pickle" the iron—that is, brush it over with some sulphuric acid solution; then kill the chemical action of this acid by brushing a solution of soda or ammonia on the iron, and finally washing away all traces of the chemicals by means of clean cold water; then thoroughly dry the iron rapidly by subjecting it to a hot temperature, and before it becomes cold, proceed to give a coat of red lead or else paint.

The scaling of paint from plaster is due to several causes. Plaster is of necessity porous, and extremely susceptible to dampness and the imbibition of moisture. The water thus absorbed may be sucked into the interior of the plaster, leaving the exterior surface dry; consequently, when a coat of paint is spread on such plaster the imprisoned water is completely prevented from escaping. But when heat from any source reaches the painted plaster, such imprisoned water will be drawn to the surface just beneath the paint, and by alternations of heat and cold it will fluctuate between the surface and interior of the plaster until the moisture has been all used up in chemically or mechanically combining with the lime salts of the plaster; such combination will be productive of crystallisation of the lime, and after a time the crystals will become reduced to a condition of dry powder, and as a consequence beneath the layer of paint there will be a pulverulent powdery mass to which the paint cannot adhere. As a result, such paint flakes off. Apart from the imbibition of moisture from the surface of the plaster, moisture may also be absorbed from the foundation surface on which such plaster is laid. Thus, bricks are porous, and if they imbibe damp from any source, such dampness will invariably reach the plaster, to be absorbed thereby, as indicated. The remedy for preventing scaling of paint from plaster is to saturate the plaster with a solution of wax in some volatile hydrocarbon, such as naphtha, paraffin, or benzine, so as to fill up the interstices in the plaster with a water-repelling substance. By such a course, water will not be imbibed either from the surface or by capillary attraction. To render the surface suitable for painting on, the wax should be well driven into the interior of the plaster by holding a brazier of coal, or some other source of heat, some little distance from the surface of the plaster. Allow the hot plaster to cool before proceeding to paint it. If the surface of the plaster show any signs of being powdery, such powder should be well scraped off before proceeding to wash it with a solution of wax.

A cheaper method of rendering the plaster non-porous is to well saturate it with a solution of hot soap and water in which rosin has been dissolved; thus, dissolve common rosin in a solution of caustic or carbonate soda by boiling, and then mix this fluid with a strong solution of soap and water—about  $\frac{1}{2}$  lb. of soap per gallon of water; well brush this into the plaster with a big brush, using it hot. Another plan is to saturate the plaster with soap-water, and when that has partially dried, lay on a solution of sulphate of iron (green copperas), sulphate of copper (blue copperas), or sulphate of alum and potash (common alum); the effect of any one of these chemicals is to convert the soap into a sebate of the metal (iron, copper, or aluminium, as the case may be), which is insoluble in water; consequently, by this means, the pores of the plaster are filled up with a water-repellent material, and thereby the plaster becomes rendered proof against the imbibition of water from any source. Another process for rendering plaster proof against absorption of water is to saturate it with a solution of iron, copper, or alumina sebate in turpentine. Such sebate is made thus: Make a strong syrupy solution of soap in water, and also a saturated solution of either of the above-named chemicals (i.e., green or blue copperas or alum) in water; mix the two solutions and collect the flocculent precipitate that falls down, wash this precipitate with water once or twice, and then dry it, and when dry or free from moisture dissolve it in hot oil of turpentine. This is the fluid required for saturating the plaster with. It will render the plaster as hard and durable as stone, and gives a splendid surface for painting on.

The last three processes can be used equally as well on brick, stone, tiles, and any porous materials as on plaster. They are much superior to silicate paints, which only disintegrate in course of time and crumble off. H. C. S.

#### BRIGHTON MASTER BUILDERS' ASSOCIATION.

ON April 19, the annual dinner of the Association of Master Builders was held at the Clarence Rooms, Hotel Metropole. The chairman (Alderman Botting, J.P.) presided, and there were also present the mayor (Alderman Sir John Blaker), Alderman Davy, J.P., Mr. G. S. Godfree, Mr. Wormald, Councillor Wilson, Messrs. Botting, Mr. Patching, Mr. Lynn, Mr. Wright, Mr. Brown, Mr. Pearce, Mr. F. M. Cox, Councillor Holloway, Mr. Sattin, Mr. Evershed, Messrs. Cox, Mr. Carpenter, Mr. Wilmer, Mr. Duke, Messrs. Garrett, Mr. Winter, Mr. Emery (secretary), Mr. G. Parsons, Mr. G. Parsons, jun., Mr. Morfee, and Mr. E. Hunter. About 60 sat down to dinner. After the loyal toasts, Mr. G. S. Godfree proposed "The Mayor and Corporation," and in doing so congratulated the association upon having present not only the Mayor, but past Mayors, in the Chairman and Alderman Davy.

#### THE LARGEST TRADE IN BRIGHTON.

Alderman Davy submitted the toast of the evening, "The Association of Master Builders." He said that under the existing condition of things it seemed to be necessary that combinations should exist among all trades and professions. Their own motto was "Defence, not defiance." He only wished some tribunal could be formed by which all disputes between masters and men could be amicably settled without recourse to strikes, which not only brought a great deal of misery upon thousands of men and their families, but great loss to the nation. The building trade was the largest in Brighton, and had done more than any other to make the town what it was now. As a health-resort, Brighton depended a great deal upon what the builders could do to make it an attractive town. Of course, there were shoddy men in their profession, as in many others; but at the same time, their number included splendid men of business. Among them were some of his best personal friends. Nothing had occurred in the trade during the past few years but what the trade committee had been able to settle, and he hoped that would long continue, to the advantage of both employer and employed. Long might the association continue to do its excellent work. The chairman, as they knew, took very great interest in the association, and did all he could to keep the masters together to do the best they could for the employés as well as employers. In acknowledging the toast, the chairman pointed out that the extension of the town depended absolutely upon those who placed their money in bricks-and-mortar, so that provision might be made for those who wished to visit and settle in the town. Their association had had a very successful year, having kept up its membership, and increased the subscription list. In every way it had been a success, and that of itself was a proof that they were doing the right thing to watch the interests of the building trade. When he said that, he meant for the benefit of the employés quite as much as the employers, and he believed the society would continue to carry on the good work it had taken in hand. In every case they tried to avoid anything that was likely to create friction. There were one or two complimentary toasts, the speeches being interspersed with songs.

#### ARCHITECTS' LICENSES IN ILLINOIS.

THE Chicago correspondent of the *American Architect* writes to that journal: It may be of interest to review the situation here in Chicago relative to the licensing of architects and the work which the board appointed for the purpose has already accomplished. After this board had been appointed by the Governor it found itself in rather a curious position—a body with a good deal of work before it, and not one cent of money in its possession with which to accomplish such work. Fortunately, one of our well-known architects, on going abroad, placed his office at the disposal of the board, so one difficulty was removed. Stationery and stamps were the next most essential things in the list of equipments, and these were temporarily furnished by the individual members of the board itself. As soon as the actual licensing was begun, a fund for running the office was established, till, at present, the board has a balance of about 13,000dol. As may be remembered, it was planned that, previous to January, 1898, all

persons who could show proof that they were practising architects should, upon the payment of 25dol., be granted a license to continue in such practice. To draw the line, especially in several of the smaller towns, between contractor and architect has been the one difficult feature of this part of the work. The accepted definition of an architect for this especial case seems to have been: A man who makes plans for buildings which he does not build himself. In most cases where there was any doubt about the applicant's living up to such definition, he has been given the benefit of the doubt. After the first of January the real work of the board began, as all applicants for license then had to pass the regular examination, the fee being no longer 25dol., but 40dol. So far, the best examination has been passed by a man who has worked up to the profession by way of the trades; the second-best test was stood by a male graduate of one of the European schools; and the third by a female graduate of an Eastern technical school. At the present time the number of licensed architects in the city is 519; in Cook County outside of Chicago, 13; in Illinois, 154. Nineteen licenses have been granted to architects from other States. The total number of applications for licenses was 793, while since January 1st the number of applications for examinations has been only 25. It was decided that in case of the application for a license from any reputable architect from another State it should be granted after the payment of the fee of 40dol., the examination to be on plans, made and submitted by him, of some considerable building actually constructed. With already a considerable balance on hand, and the likelihood of a continual small revenue yearly from the licenses, the question of the use of such funds for the advancement of the profession will naturally arise. At present the matter stands that whatever there is in excess of 2,500dol. shall be turned over to the State treasury "for the credit of the board," which appears somewhat vague. There will occasionally be small legal expenses in connection with unprofessional practice, one of the few cases where the board can itself discipline being where a licensed practitioner shall be guilty of unprofessional practice. In case of an architect failing to use his seal on his drawings the board may revoke his license, but all other prosecutions for offences against the law must be undertaken by outsiders. All this work has been accomplished under the State law; but the matter is now being discussed of a revision of the city ordinance requiring that all drawings shall be made by licensed architects, with a few insignificant exceptions.

#### CHIPS.

The partnership hitherto subsisting between H. E. Kirk, J. A. Knight, and Chatwin, under the style of Kirk, Knight, and Co., contractors and builders, Sleaford, has been dissolved.

In consequence of a strike which broke out at Copenhagen on Thursday in last week among house painters and men employed at a number of iron foundries, the employers' union has decided to enforce a general lock-out of all trade unionists unless the strike is settled by negotiations or arbitration. Thirty thousand men are affected.

Easter week at the Mart, Tokenhouse-yard, was, as usual, dull. Little was on offer save brick and mortar investments, and these, as usual, met with a ready sale, and, in instances, at capital prices, some freehold shops near the Angel, at Islington, exciting keen competition. The returns for the week amounted to £28,785, as compared with £62,605 for the corresponding period in last year, which was not, however, a holiday week.

The design of Messrs. Cheers and Smith has been selected in a competition for a new board school to be built, at a cost of £6,000, in Accrington-road, Blackburn. Mr. A. Boyle, of Manchester, was the assessor, and 13 sets of plans were submitted.

Particulars of a proposal of the Newport, Mon., Town Council to borrow £30,000 for the construction of a new road to facilitate the development of the eastern side of the Usk and the approach to the Liswerry district were laid before Mr. W. D. Ducat, inspector under the Local Government Board, on Thursday, at Newport. The town clerk said that about one mile and a half of new road, known as Corporation-road, had already been laid down, while there remained still another mile or thereabouts to be constructed. It was also proposed to connect the Liswerry district to the Corporation-road by a 40ft. road, at a total cost of £3,950, of which the owners of contiguous land had agreed to contribute £1,685.

## OBITUARY.

MR. AUGUSTUS LAVER, formerly a well-known architect in extensive practice in the United States and Canada, died at his home in Flood's Building, San Francisco, a fortnight ago. He first became conspicuous as the designer of the Canadian Parliament House, at Ottawa. This was hardly completed when he won, in competition, and in connection with Mr. Fuller, of Albany, the commission for the New York State Capitol. A great deal of work had been done in carrying out their design when the State Government suddenly decided to take the building out of Messrs. Fuller and Laver's hands, and confide it to an artistic triumvirate, composed of Messrs. Richardson, Eidlitz, and Olmsted. Messrs. Richardson and Eidlitz took charge of the building, while Messrs. Fuller and Laver removed to San Francisco, where they had won, also in competition, and eventually carried out, the commission for a new city-hall. Besides this building, Mr. Laver designed the great Flood mansion, at Menlo Park, together with another, for Mr. Coleman, in the same neighbourhood, as well as the Flood Mission, and many less important structures. He had been an honorary corresponding member of the Royal Institute of British Architects since 1879.

MR. WILLIAM M. WATSON, for very many years county surveyor of Bedfordshire, died on Tuesday last at his residence, Wren Park, Shefford, Beds, at the advanced age of 88 years. The funeral will take place at Henlow Church on Monday afternoon next.

THE death is announced of Mr. WALTER DAVIES, architect and surveyor, of 6, Waterloo-place, S.W., and 91, Burnt Ash-road, Lee, Kent. Mr. Davies was elected a member of the Society of Architects in 1887, and was at one time a valued member of its council; he had been a Fellow of the Surveyors' Institution since November, 1891.

THE death occurred, after a long illness, on Wednesday in last week at his residence, 182, Cromwell-road, S.W., of Mr. ROBERT COLLIER DRIVER, F.S.I. The deceased gentleman, who was in his 82nd year, was for many years associated with the well-known firm of Messrs. Driver, auctioneers and surveyors, 41, Whitehall. He became the sole surviving partner in 1855, and, after a most successful career, retired from active interest in the business in 1876. He was engaged in all the great Metropolitan improvements. He purchased the land for the London, Brighton, and South Coast Railway Main Line, and a large portion of that for the Great Western Railway. As an auctioneer, Mr. Driver had at one time one of the largest practices in the United Kingdom. From about 1860 to 1875 his sales closely approximated one million sterling. He was also engaged in the development of many important building estates in the suburbs of London. Mr. Driver was one of the founders of the Surveyors' Institution, his name being No. 9 on the roll of membership, and a few years since he served as president. He was also past master of the Clothworkers Company, and a member of the Commission of Lieutenancy for the city of London. The funeral took place on Tuesday morning at St. Jude's Church, South Kensington.

THE death occurred at Paris on Tuesday, at the age of 72, of the painter GUSTAVE MOREAU, the French Pre-Raphaelite. Moreau, who has died in the little house in the Rue La Rochefoucauld where he was born, was the son of an architect and early entered the Ecole des Beaux Arts, where he was a pupil of Picot. His first appearance at the Salon was in 1852 with a *Pietà*, and in the following year he exhibited the large canvas "An Episode of the Song of Solomon," now in the Museum of Dijon. His "Edipus and the Sphinx" was first seen in the Salon of 1864. Among others of his pictures are "Orpheus torn by the Mænads" (Luxembourg), "Diomedes devoured by his Horses," and "Salome." He was elected a member of the Academy of Fine Arts in 1888, and became professor at the Ecole des Beaux Arts in 1892.

The Council of the Kent Archeological Society have arranged to hold the 1898 meeting of the society at Deal, towards the end of July. The trip on the first day will include Ash, Eastry, and Woodnesborough. On the second day Walmer will be visited, and then St. Margaret's Bay, where luncheon is to be provided. The return journey will be by the way of East Langdon, Whitfield, and Sutton, thence to Deal.

## PROFESSIONAL AND TRADE SOCIETIES.

BRISTOL SOCIETY OF ARCHITECTS.—The annual general meeting of this society was held at the Fine Arts Academy, Queen's-road, on Monday last, Mr. F. W. Wills in the chair. The president, Mr. W. L. Bernard, F.R.I.B.A., and vice-presidents, Messrs. Joseph Wood and W. V. Gough, were re-elected, and a vote of thanks was accorded to the retiring hon. sec., Mr. W. S. Skinner. Mr. H. Dare Bryan was elected hon. sec. for the ensuing session.

THE CIVIL AND MECHANICAL ENGINEERS' SOCIETY.—A meeting of the above society was held at the Hotel Victoria, Charing Cross, on April 14, Mr. B. B. Dodley, vice-president, in the chair, the paper for discussion being "Pipes and Pipe-Laying," by Mr. Alfred Hanssen. The author first drew attention to the largeness of the subject, but explained that he would beg to limit the paper to cast-iron and stoneware pipes, and drew attention to the fact that to a great extent the health of the town and country depended on the use of proper pipes, several specimens of pipes being exhibited, amongst others a very fine specimen of a cast-iron pipe that had been made over 100 years. One of the most important points in pipe-laying being the proper jointing of two pipes, several methods were discussed, and also the various methods used in different countries.

LIVERPOOL ARCHITECTURAL SOCIETY.—In commemoration of the 50th anniversary of this society a dinner was held on Monday evening in the Walker Art Gallery, Liverpool. Mr. W. E. Willink (president) occupied the chair, and a large number of members partook of a repast in the room devoted to exhibition of the work of the Schools of Art, Architecture, and Technology. Professor F. M. Simpson submitted the toast of "The Royal Institute of British Architects and the London Architectural Association." He said the Association had been particularly successful in the direction of giving great assistance to young architects. Mr. E. W. Mountford (past president L.A.A.), in replying, attributed the success of the Institute of British Architects largely to its system of examinations. Liverpool, he continued, was to be congratulated upon the existence of its School of Architecture and Applied Arts, and partly on the fact that the management of affairs was in the hands of Professor Simpson, Mr. Allen, and Mr. Anning Bell. The city possessed some fine buildings, St. George's Hall, their centrepiece, being perhaps the finest in England. It seemed to him, moreover, that there were men in Liverpool who were prepared to pay for architecture, which was a great thing. Unfortunately, architects suffered from this disadvantage, which painters and sculptors did not experience—they were limited by the means at their disposal, and unless they had wealthy men, with the will to spend money, they could not produce fine buildings. He had been delighted to see the other day in the papers a reference to the fact that in some Liverpool buildings the committee had accepted a tender which came to something like double the architect's estimate. That piece of fortune had never happened to him, but it was a very good thing. It was distinctly in favour of the Liverpool architects. Mr. Hampden W. Pratt, president of the Architectural Association, in responding for that body, said it might be stated with perfect truth that the architects of the future were for the greater part those who had passed, or would pass, through the ranks of the Architectural Association. At the present time, when they were being, as it were, assailed by boards of technical education, which were to some extent their competitors and rivals, they endeavoured, as an association, to hold their own, and they did so on the ground that, however competent these technical boards and classes and institutes might be, they could not, and never would, take the position that the Architectural Association had been able to, and still could take in regard to the profession. One of the chief aims of the association had been mutual help, and until the last seven years it had been conducted upon voluntary principles. Within the period named they had been obliged to advance with the times, and they had a large number of paid teachers in their classes, with the result that their system of education had been more perfect than before. Their association was able to offer advantages which no technical school or board could offer. Their influence did not merely extend throughout the whole of this

country, but abroad, the membership, which was the largest in the history of the association, being over 1,200. They had existed not for their own individual benefit, but for the art which they loved and were privileged to represent. Mr. H. Hartley, in proposing "The Allied Societies," described the streets of Manchester as furnishing food for melancholy. Mr. J. Ely (president of the Manchester Architectural Society) acknowledged the toast, without comment upon Mr. Hartley's caustic allusion to Mancunian architecture. Mr. T. D. Barry, as one of the original founders, appropriately proposed the toast of "The Liverpool Architectural Society," his speech being full of reminiscence. The president, in reply, described the architectural profession as being, in spite of its responsibilities, one full of pleasures of a varied description. Courteous reference was subsequently made to "The Guests" and "The President."

## CHIPS.

The members' soirée and smoking concert of the Architectural Association will be held on Friday in next week at the Café Monico, Piccadilly-circus, W.

The Treasury has taken advantage, the *Athenæum* says, of the retirement of Mr. C. L. Eastlake from the National Gallery to effect a saving in the salary of his successor, Mr. H. H. Turner, who, instead of Mr. Eastlake's £875, is to have only £350 a year. The post is thus brought on a level with that of the Keeper of the Millbank Gallery.

The Chancellor of the Exchequer unveiled, on Monday, a white marble bust of the late Lord Randolph Churchill, which has been placed almost opposite that of the late Mr. W. H. Smith in the corridor of the members' staircase leading from the Lobby of the House of Commons. The bust is the work of Mr. Waldo Story.

On Saturday afternoon the Earl of Crewe laid the foundation-stone of a new chancel which is being added to Christ Church, Crewe.

A new peal of six bells has been dedicated at Mistley Church, Essex. The peal weighs 46½ cwt., and has been cast by Messrs. Bowell and Son, of Ipswich.

The Manchester Corporation are carrying out, under Parliamentary powers, an important street improvement in Shudshill, which will be widened so as to allow of a double line of tramways. At the same time the spar thoroughfare of Mayo-street will be reduced to 36ft. and carried into Corporation-street, thus forming a new approach to the market from Victoria Station.

At Plymouth a local government board inquiry has been held into an application by the corporation for sanction to borrow £22,306 for the erection of a museum and art gallery, \$550 for street improvements, £2,500 for public lighting, £15,800 for the reconstruction of sewers and repairing of streets, and £1,340 for the purchase and adaptation of premises for the purpose of a fire and police station.

During a thunderstorm on Saturday afternoon the parish church of Swanton Morley, four miles north-east of Dereham, was struck by lightning. The south-east angle of the parapet of the lofty tower was shattered, and portions of the masonry fell on to the nave and south aisle roofs, causing considerable damage. The clock was also struck, the electric fluid severing the steel wire rope which carries the heavy weights, and these in consequence fell into the church and broke in pieces the massive oak chest containing the documents of the parish. The building was not injured by lightning, and neither were any of the fittings.

At a meeting of Aberdeen Town Council on Monday the finance committee recommended the restoration and retention of Greyfriars' Church as a place of worship. The committee, having found it to be an absolute condition of the donor of £10,000 that the church should be retained, were forced to consider what could be done to secure this money, and at the same time conserve the public interest. On condition of getting the £10,000, the University would also obtain £20,000 from the Government. After discussion, the report was adopted.

The Perth Police Commission adopted on Monday a report by Messrs. Blyth and Westland on the offers for the new bridge across the Tay, recommending the acceptance of estimates for the erection of the bridge at a cost of nearly £20,000. The estimates accepted are nearly double what was anticipated when the idea of the bridge was first mooted, but the bridge will be widened 10ft. from that originally proposed.

The annual spring holiday excursion of the Edinburgh Association of Science and Art took place on Monday, when some 200 of the members visited the Atlas Works in Springburn and the power station of the Glasgow District Subway Company, Scotland-street, South Side, Glasgow.

CONTENTS.

Clothing Ideas ... 551  
 Model Specifications.—IX. ... 551  
 Royal Institute of British Architects ... 553  
 The Surveyors' Institution: Visit to Manchester ... 554  
 Stage Mechanism ... 556  
 Amalgamated Society of Carpenters and Joiners ... 558  
 Sanitation and the Fine Arts ... 558  
 A Chapter in the History of Pottery ... 559  
 Liverpool Landing-Stage Extension ... 559  
 "Lincoln Cathedral," by Peter De Wint ... 559  
 The Dome of the City Hall, Philadelphia ... 560  
 Wrought Steel Pipe-Clips ... 560  
 The Scaling of Paint ... 561  
 Brighton Master Builders' Association ... 561  
 Architects' Licenses in Illinois ... 562  
 Obituary ... 562  
 Professional and Trade Societies ... 562  
 The Building News Directory ... IX.  
 Our Illustrations ... 563  
 Building Intelligence ... 562  
 Competitions ... 563  
 Correspondence ... 563  
 Intercommunication ... 564  
 Legal Intelligence ... 564  
 Parliamentary Notes ... 565  
 Water Supply and Sanitary Matters ... 565  
 Stained Glass ... 565  
 Our Office Table ... 566  
 Meetings for the Ensuing Week ... 567  
 List of Competitions Open ... 567  
 List of Tenders Open ... 568  
 Trade News ... 568  
 Latest Prices ... 568  
 Tenders ... 590

ILLUSTRATIONS.

LINCOLN CATHEDRAL.—ABBEY MANSIONS, VICTORIA STREET, S.W.—FIRST AND SECOND PREMATED DESIGNS FOR BATTERSEA PUBLIC BATHS.—THE PORCH, LOWER COURT FARM, UPPER LANGFORD, SOMERSETSHIRE.

Our Illustrations.

"LINCOLN CATHEDRAL," BY PETER DE WINT.  
 (For description, see p. 559.)

ABBEY MANSIONS, WESTMINSTER.

This block of buildings, situated at the corner of Victoria-street and Orchard-street, Westminster, has been erected for Her Majesty's Office of Works, comprising nine floors and about 300 rooms to be used as Government offices. The building is erected in Portland stone with red brick facings, and is fireproof construction throughout. The buildings have been erected and carried out by Mr. W. R. Rickard, contractor, City-road, at a cost of £95,000, from the designs and under the superintendence of the architect, Mr. Chas. J. Chirney Pawley, 2, Prince's Mansions, Victoria-street. The red brick facings are by Messrs. T. Lawrence and Sons, of Bracknell, Berks. The lift is by Messrs. Waygood and Co., Falmouth-road, Great Dover-street.

BATTERSEA PUBLIC BATHS AND WASHHOUSES.

The design illustrated was awarded the first premium in the recent public competition, and has since been adopted by the vestry. The conditions of the competition laid great stress on the importance of so arranging the building as to render it capable of easy extension, its position being left to the judgment of the several competitors. In order, therefore, to meet this requirement, a portion of the site—that between the public washhouse and the men's slipper baths—is left open, so that either or all of these departments might be enlarged; and the reading room is placed on the ground floor, so that the women's slipper-baths might be extended by occupying the space so utilised if required, the reading-room being then removed to the first floor. The principal entrances are placed in the Battersea Park-road frontage, with separate approaches to the men's baths and swimming-bath and to the women's baths respectively. These entrances are divided by a ticket-office and screen, and each has its entrance-hall and lobby. The slipper baths are provided with separate waiting-rooms and attendant's box, so arranged that one official can supervise each dual set of baths. Centrally placed is the superintendent's office, with private entrance and staircase leading to the committee-room and the private apartments on the first floor, and also to the establishment laundry, and to the public laundry by an official corridor. Special attention has been paid to adopting the swimming-bath for purposes of entertainment, ample entrances and exits being provided, both from the ground floor and also from the galleries. The public washhouse and laundry are entered from Cringle-street, and this department has entrance hall and corridor,

waiting-room, bonnet-room, &c., and a crèche. There will be 67 washing compartments and drying-horses. The house laundry is placed on the first floor over a portion of the men's baths, and in direct communication with the matron's apartments. A lift is provided in connection with it. The lighting will be effected by lantern lights, and artificially by electric light. Mr. Francis J. Smith, F.R.I.B.A., of 17B, Great George-street, Westminster, is the architect, and it is the intention of the vestry to erect the building by their Works Department, the efficiency of which has recently been greatly increased by the erection of extensive workshops from the designs and under the superintendence of Mr. Pilditch, the surveyor to the vestry.

SECOND PREMATED DESIGN FOR THE NEW BATTERSEA BATHS.

In this design the whole of the public baths and washhouses, with all adjuncts, are placed on the ground floor, leaving ample room for extension; the towel laundry and engineer's department being placed in the basement well lighted by areas. Towel-shoots are placed in each attendant's room in connection with towel laundry, and a towel lift in connection with pay-box. The committee room and superintendent's residence is on the first floor, approached by a staircase leading out of the entrance-hall; the accommodation consists of sitting-room, kitchen, scullery, larder, w.c., and three bedrooms. Lavatories are provided for the use of the committee. A coal-lift communicates with basement. The public entrances to baths are in Battersea Park-road, one entrance for men and for women, with separate vestibules leading to large entrance halls, the ticket-office and superintendent's room being placed centrally. If a separate office was required for superintendent, it would be placed where shown. The women's entrance leads from hall direct into first and second-class women's slipper baths. The men's entrance leads from hall direct into first and second-class slipper baths and to swimming-bath. The swimming-bath is entered through large hall. Two swimmers' clubrooms are placed close to entrance; each room has a w.c. and lavatories. The bath is entered at the deep end, having a movable diving-board, hot and cold shower spray, dressing-boxes along two sides and one end, a stepped gallery 9ft. wide runs round two sides and one end, the floor being at the angle of 45°. The gallery is approached by well-lighted staircases. Lavatory and w.c.'s are provided for on landings; the attendant's room adjoins the entrance and has a towel shoot; w.c.'s and urinals are placed at side of bath, well ventilated into large area. A foot-washing bath is also provided. It being intended that the bath should be used as a public hall for entertainments, a separate entrance is placed in Battersea Park-road, with large vestibule, thus obviating the necessity for closing any portion of the baths when entertainments are being given; the two clubrooms would be used as cloak-rooms. An emergency exit from gallery is shown, leading into Cringle-street. Emergency exits from ground floor are also shown in Cringle-street, in order to comply with L.C.C. regulations. Two dressing-rooms are placed at stage end of bath for the use of artistes, each having a lavatory and w.c. The dressing-boxes are all made collapsible and fit into the bays forming panelled dado. The whole area of bath will be covered with a pitch-pine floor with platform at end. Ample storage is provided in basement for movable platform, chairs, &c. The six men's first-class slipper baths, thirty-two second-class ditto, three women's first-class ditto, and nine second-class ditto, are each provided with large waiting-rooms; the attendants' rooms having towel-shoots being so placed as to allow of the one attendant supervising each department. The men's baths have w.c.'s, lavatories, and urinal; the women's, w.c.'s and lavatories, all ventilated into areas. The baths are all top-lighted and ventilated. The public washhouse and laundry is approached from Cringle-street. The pay-office is placed centrally, and has turnstiles. On the left of entrance is placed the waiting-room, and immediately opposite the crèche, having a fireplace and lavatory and w.c. A corridor leads out of waiting-room to washhouse past the w.c.'s, and room for temporary storage of wearing apparel. The washhouse contains 72 washing stalls, each 3ft. 6in. wide, with iron fittings for hot and cold water and steam. These washers are so placed that a woman may particularly observe her own drying-horse; 48 drying-horses

are placed at one side and 24 opposite, each 6ft. long, having a steam-heated battery drawing air from engine-room and ironing-room, and driving heated air in through the closets at a temperature of 130°, thus insuring rapid drying, ventilating shafts being provided at back of closets. Five centrifugal wringers are conveniently placed at the end of washing-stalls. The ironing-room adjoins and contains two box mangles, and having ironing stoves and tabling. A door leads to room for temporary storage of wearing apparel, and also to corridor past crèche, and so into street, thus avoiding the necessity for women re-entering the washhouse. The estimated cost was £20,432. The building thus designed is by Mr. J. Hatchard Smith, F.R.I.B.A., 41, Moorgate Station Buildings, London, E.C., to whom the second premium was awarded.

THE PORCH, LOWER COURT FARM, UPPER LANGFORD, SOMERSET.

This interesting little Renaissance porch is situated on the north side of the house, which belongs to General Sir Lintorn Simmons, G.C.B. The date 1611 occurs on two small shields in the spandrels on the side elevation shown. The porch is constructed of freestone, but has been repaired in places with cement in such a way that some of the mouldings on the bases of columns and the pedestals are almost indecipherable. The cornice at the eaves is covered with thick cast lead, and the pantiles are set in mortar at the verge, and are flashed with the same material where they abut the wall of the house. A freestone chimney-piece, bearing the date 1601, from the same house, appeared in the BUILDING NEWS on Sept. 24, 1897. T. BRADFORD BALL.

CHIPS.

A stained-glass window is about to be placed in the west front of the church of St. Ignatius the Martyr, Sunderland, in memory of the late Dr. Lightfoot, Bishop of Durham. The late bishop founded the church, at a cost of £10,000, in 1887, in commemoration of his 10 years' ministry in the diocese of Durham. The window depicts nine scenes in the life of Bishop Lightfoot.

The New York Public Library, the competition for which excited some interest in the profession, will not be built at present, Mayor Van Wyck having decided that the financial condition of the city does not warrant the expenditure of the money that the building will cost. The successful architects, Messrs. Carrère and Hastings, have been wise enough to stipulate that their fees shall be paid them by the city, even if the municipal authorities "should fail or neglect in due time to award contracts or to provide for the construction and completion of the said building."

The new Sunday-school which has been erected in connection with Mount Pleasant Wesleyan Chapel, Lockwood, Huddersfield, was opened last week. The leading feature is a large assembly-room, which can, if need require, be used for public worship. A gallery occupies two sides and one end of the room, and a recess for an organ the other end, while at the same end in the well of the room there is a platform. Classrooms open out from the main room. There is also a ladies' parlour, and in the basement a tea-room and kitchen. The building has been erected from plans prepared by Mr. B. Stocks, of Huddersfield, and the cost is about £4,000.

A well-known church in the centre of Liverpool—St. John's, Old Haymarket—is about to be demolished to permit of improvements being carried out in that quarter of the city. In the course of farewell services which were held on Sunday week, it was stated that the demolition of St. John's and of the sister church of St. George would be followed by the erection of four or five new churches in localities in which they may be required.

Port Glasgow School Board have decided to erect an additional story to Jean-street school. This will give accommodation for 460 more scholars, and is estimated to cost about £6,000.

At Wimbledon the foundation-stone has been laid of a new building which is to adjoin St. Mark's Church, and serve the double purpose of a church-house and a parish-room and Sunday-school. The building will include a large hall 74ft. by 40ft., having at the east end a raised platform, and at the west end a gallery. Accommodation will be provided for about 500 persons in the body of the hall, and some 150 in the gallery. Three committee-rooms and a kitchen are also included in the plans. The total cost of the work, including furniture, will amount to about £2,250. Mr. J. Bignell, of Wimbledon, is the architect.



THE PORCH · LOWER · COURT · FARM · UPPER · LANGFORD · SOM



† SECTION · AA †

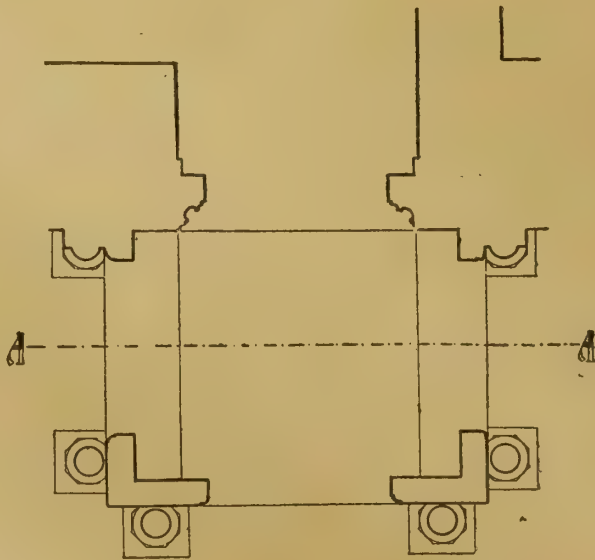

PLAN

FRONT · ELE

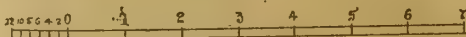

SCALE · OF · FEET ·

WILTSHIRE · DATE · 1611 ·



· ENRICHMENT · OF · OVULO · FULL · SIZE ·



PLANS · OF · SOFFITS · OF · ARCHITRAVE · (LOOKING · UP)



· FRONT ·



· SIDE ·

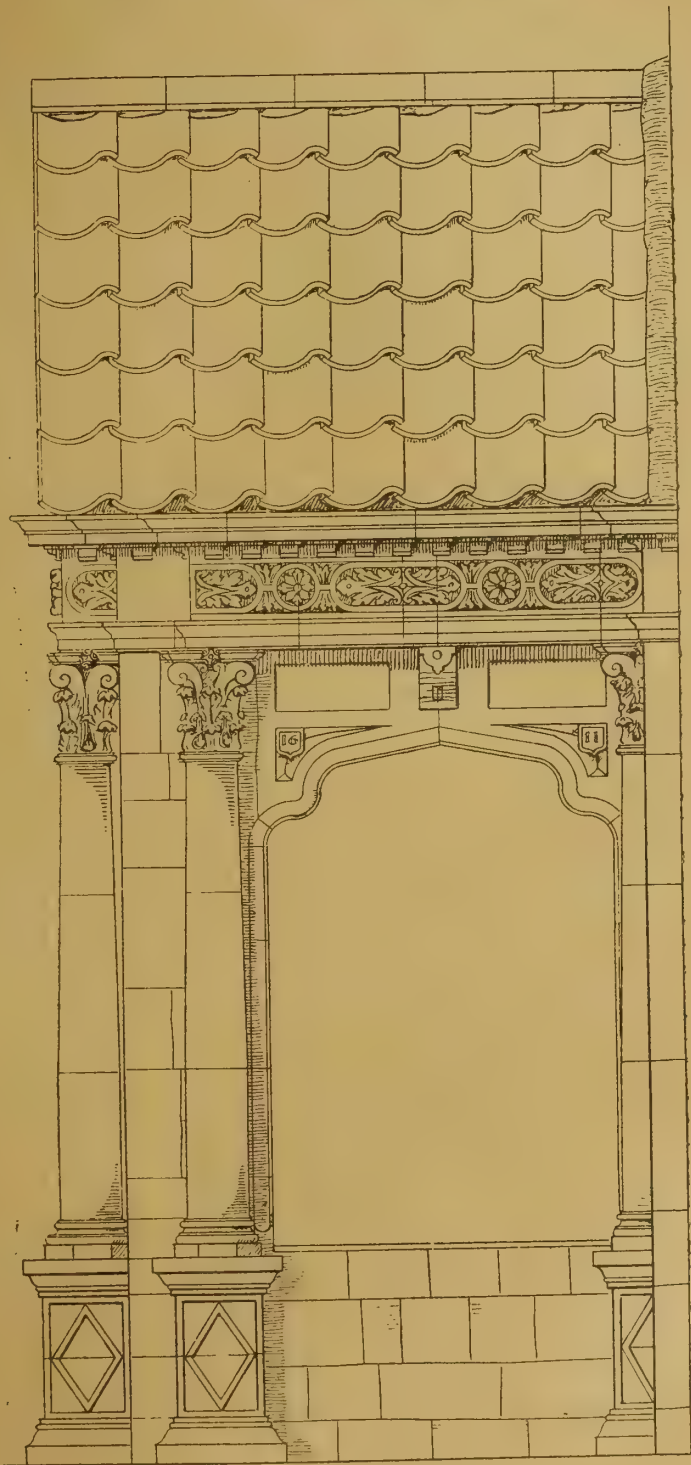
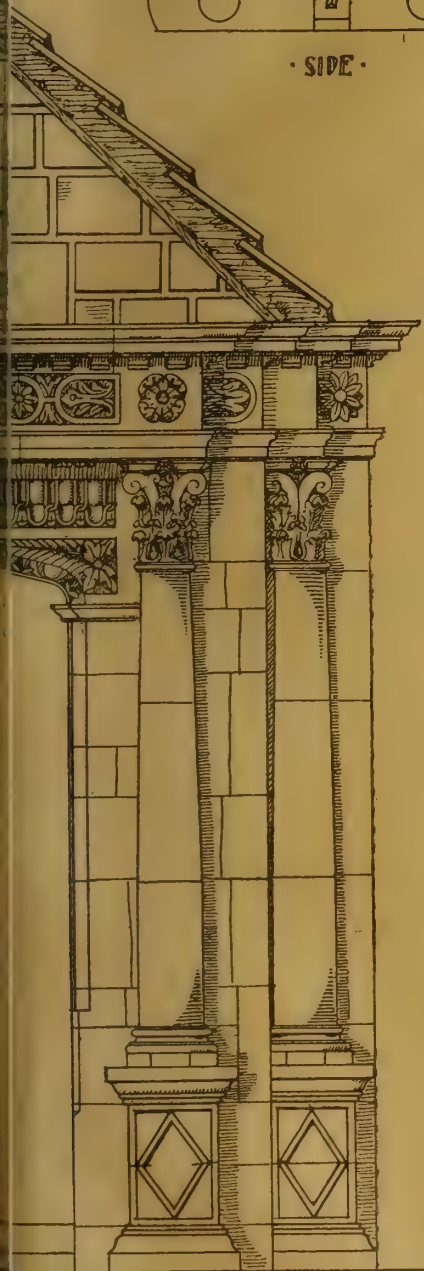

ON ·

· SIDE · ELEVATION ·

· SCALE · OF · FEET ·



J Bradford Ball  
Mens et Val.

## Building Intelligence.

**HAMPSTEAD.**—On Saturday afternoon an official inspection was made by the Hampstead Vestry of the new administrative block of the public baths in the Finchley-road. The old front of the baths was pulled down in consequence of the carrying out of the Great Central Railway works, and the company paid the vestry £8,300 and gave them a larger area of ground to rebuild upon by way of compensation. The new block is built in the English Renaissance style of an Early type, and has cost nearly £9,000. The building is faced with red brick with dressings of Portland stone, and the plinth is of grey granite from Aberdeen. Messrs. Spalding and Cross were the architects, and Mr. Kingler, of Oxford, was the builder. The accommodation of the baths has been largely added to, and now includes four large swimming-baths and a large number of slipper-baths.

**KING'S CLIFFE.**—The church of All Saints', King's Cliffe, which has undergone restoration, was opened by the Bishop of Peterborough, on Thursday in last week. The four 12th-century windows of the ringing chamber are the only remains of Norman work in the church, and have been inserted in the rebuilding of the tower and spire. These windows, with the Early English of the belfry and the arches of the ground story of the tower, denote a rebuilding of the tower and spire in the 14th century. The nave, aisles, transepts, and porches are of the Perpendicular period. One respond remains on the north side of the chancel as part of its Early English construction, while the tower rests on 14th-century arches. The north porch has been rebuilt on exactly the same lines as before, with the floor-line restored to its ancient level. The stonework of the tower and spire has been repaired and pointed, and the crosses to the spire lights restored, and lightning-conductor supplied. A repair and pointing of all the exterior stonework of walls and parapets has been effected, and the lead roofs repaired with down-pipes and dry area. The windows of the nave and aisles have been repaired and restored with their original iron-work, and the best of the old glass reused and made up with new to match. Beautiful fragments of ancient stained glass have been found stowed away in the church, and scattered here and there in the village, and have been fitted together as well as the broken and missing parts will admit, and put into the tracery heads of the windows. The font has been moved, and set on a new stone step. The work has been carried out by Messrs. Roberts Bros., builders, Stamford, under the direction of Mr. J. C. Traylen, A.R.I.B.A., diocesan surveyor, Stamford. A new clock has been made by Messrs. Rowley Bros., Gray's Inn-road, London.

**MAIDENHEAD.**—The Bishop of Oxford consecrated on the 14th inst. the first portion of St. Peter's Church, Furze Hall. It is built in the Early English style, of red brick, relieved with stone dressings and bands and diaper work in grey brick. The roofs are covered with Broseley tiles. When complete, the building will consist of a nave 57ft. long by 19ft. wide, with north and south aisles; chancel 29ft. in length and the same width as the nave, seating accommodation being provided for about 300 people, in addition to the choir and clergy. The line of the roof over the nave and chancel is continuous, there being no chancel arch, but in its place a lofty and handsome oak screen is to be erected. There is no window in the east wall immediately over the altar, but tall traceried windows in each of the side walls of the apse sufficiently light the sanctuary. The architect is Mr. E. J. Shrewsbury, A.R.I.B.A., Queen Street Chambers, Maidenhead, the builders being Messrs. Silver and Sons, Limited, of Maidenhead.

**MANAFON.**—St. Michael's church was reopened after restoration on Wednesday week. The east wall has been thoroughly strengthened by the addition of two buttresses, the east window raised to allow space for a reredos, and new inner sills and lintels placed to all the windows, the plaster removed from the walls, and the joints pointed. All the floors were relaid—the chancel and sacrum with glazed encaustic tiles, the aisles with terracotta tiles and wood blocks under the seats. All the woodwork is of oak, and, wherever possible, the old oak work has been utilised and incorporated with the new; one part

bearing the date 1608 now forms the front of the super-altar. An oak traceried rood screen now divides the chancel from the nave, at the north end of which is a carved pulpit on a stone base, while at the south is a space for the organ. The pulpit, which was designed by Messrs. Protheroe and Philpotts, Cheltenham, was a special gift, as was the oak eagle lectern and the organ. The architects were Messrs. Douglas and Minshall, Chester.

**PERTH.**—A special meeting of those interested in St. Ninian's Cathedral was held in the Station Hotel, Perth, on Friday, to consider as to improving and enlarging the cathedral. The Bishop of St. Andrew's, who presided, explained what was proposed to be carried out, and said the alteration would give an unbroken view of the interior of the building. A sum of £10,000 would be required, and they had in hand £2,401 10s., not counting nearly £1,000 for the Wordsworth memorial. A resolution was adopted by the meeting recognising the importance of proceeding at once with the improvement of the cathedral, and a committee was appointed to raise the necessary funds.

**SOUTHPORT.**—On Saturday, the Bishop of Liverpool consecrated the new Church of Emmanuel, Cambridge-road, Southport, which has been erected as a chapel-of-ease to the Parish Church of North Mèols. The site has been given by the lady of the manor, Mrs. Hesketh, who has also defrayed the cost of the sanctuary. The plan consists of a nave and aisles of five bays with double transept, chancel, and sanctuary. Among the special gifts are the vestry, narthex, screens, boundary wall, gates, &c., brass lectern, marble pulpit, and marble font. Apart from all these special gifts, the cost of the building has been about £18,000, and when the whole scheme is completed by the erection of a tower 108ft. in height and vestries, the total cost will be about £23,000. The church, which is Early Perpendicular in style, will provide sitting accommodation for 1,200 persons. Messrs. Preston and Vaughan, of Manchester, are the architects.

**TRETFORD.**—On Friday a special meeting of the town council was held to consider a report upon the present condition of that portion of the town-hall comprising the county-court room and the old council chamber. The report, prepared by Mr. H. J. Green, architect, of Norwich, stated that the whole of the north gable end proved upon examination to be built upon little or no foundation, and to be, in consequence, much fractured, and out of the perpendicular. It was practically useless to underpin or in any way repair the structure, the only satisfactory method being to take down the end in question, and rebuild it on solid foundations. In connection with this work, other small repairs to portions of the building would be necessary, but in any case the architect strongly discountenanced the adoption of any temporary methods in dealing with the north gable end. The mayor expressed the hope that whatever work might be undertaken, the original form of the building would be adhered to. It was decided that the county-court fittings should be transferred to the large court-room, and it was unanimously resolved that Mr. Green be requested to prepare plans and specifications at once, and that until the work has been carried out the hall be not let to the public for any purpose whatever.

**WELLINGTON, SALOP.**—All Saints' parish church, Wellington, will shortly be closed for extensive alterations and repairs. It is proposed to remodel the interior altogether. The existing unsightly iron columns will be cased with marble, making them more massive and attractive. The new columns and entablature will be of the Doric Order on the ground floor, and of the Corinthian Order above. The pitch of the galleries will be increased, so as to afford the worshippers greater facility for seeing below. A new feature will be a lofty oak screen, separating the chancel from the nave, and forming a morning chapel and chamber for the organ. The chapel will contain movable seats, so as to permit of its being used for ordinary services. The organ, remodelled, will be brought down to the ground floor, and new stalls provided for the choir. A portion of the galleries at the east end will be removed, but the seating accommodation will not be curtailed, as compensation will be found in the rearrangement of the seats. The heating and ventilation of the church will be rearranged and perfected. Mr. Dalgleish, of Wellington, is the architect.

## COMPETITIONS.

**LUDLOW.**—At the last meeting of the town council the Public Lighting Committee reported that in answer to an advertisement for the best and most economical schemes of electric lighting for the borough they received ten schemes from engineers. They had considered these schemes, and were of opinion that Mr. J. S. Edright, of 202, Holland-road, Kensington, was entitled to the premium of £20. The report was adopted.

**PORT ELIZABETH, S.A.**—For the public library and Savage Memorial Hall to be erected at Port Elizabeth thirty-seven designs were sent, which were marked by the librarian as received from 1 upwards. One design was rejected in consequence of being distinguished by a motto. The assessors, Messrs. J. W. Hammersley-Heenan and Richard Wright, with the assistance of Mr. W. T. Hollands, F.R.I.B.A., accorded the first premium of 100 guineas to design No. 1, which proved to be by Mr. Henry A. Cheers, of Twickenham, London, and the second premium to No. 36, by Messrs. Charles E. Bateman and Herbert Bartland, of 81, Edmund-street, Birmingham. Mr. Cheers' design shows a building finely treated in the Elizabethan style, the estimated cost of erection being £22,000.

## CHIPS.

An infants' department is about to be added to the church schools at Guarrington, near Sleaford, from plans by Mr. Kirk.

The recumbent statue for the tomb of the Duke of Clarence and Avondale is about to be placed upon the lid of the sarcophagus in the Albert Chapel at Windsor Castle.

Lieut.-Colonel A. C. Smith, R.E., L.G.B. Inspector, has held an inquiry at Colchester into the corporation's application for sanction to a loan of £36,000 for the erection of the town-hall.

The first section of the new church of St. Michael and All Angels, at Little Ilford, has been consecrated. The church, which replaces an iron structure, is of red brick with stone dressings, and consists of a nave and its aisles. The floor is of woodblocks, and the window of cathedral glass in lead sashes.

An inquiry was held at Rhayader, on Saturday, by Colonel W. E. Slacke, Local Government Board Inspector, with references to an application made by the Radnorshire County Council to the Local Government Board to issue a provisional order authorising the said council to borrow the sum of not exceeding £32,000 for the purpose of building an asylum jointly with Breconshire at Talgarth. There was no opposition. The cost of the new asylum is estimated at £141,000, of which Breconshire has to provide £99,016 and Radnorshire £41,983.

The first arbitration case for the acquisition of properties scheduled under the Glasgow Improvement Act of last session has been held on Monday, Tuesday, and Wednesday in this week, in the Windsor Hotel, Glasgow. The claimant is Mr. Patrick Neeson, and the property to be taken is situated in King-street, City, part of it being occupied by Mr. Neeson himself as a public-house. The amount claimed for the property and the good-will of the business is £9,000. The arbiters are Mr. R. P. Lamond, for the claimant, and Mr. W. R. Copland, C.E., for the Improvement Commissioners, with Sheriff Jameson, Edinburgh, as oversman.

Messrs. E. H. Shorland and Brother, of Manchester, have just supplied some of their patent Manchester grates to the Richmond Lunatic Asylum annexe, Dublin.

On Thursday afternoon in last week the foundation-stone of a new Wesleyan chapel for the village of Barugh, near Malton, was laid by Mr. E. W. Beckett, M.P. Mr. E. Taylor, of York, is the architect, and the contract is in the hands of Mr. C. Mansfield, of York.

The new butchering department and stables for the Hetton Downs Amicable and Industrial Society, Limited, was formally opened on Saturday. The buildings are of Sherburn brick, roofed with blue slates, and the roofs are surmounted with ornamental ventilating turrets. The front has a total length of about 90ft. facing into Regent-street, while the back elevation is in Princess-street. The contractor is Mr. Robert Wade, of High Moorsley, and the clerk of works Mr. George Oates, of Leamside. The architects are Messrs. Barnes and Coates, A.A.R.I.B.A., of Sunderland and West Hartlepool.

The Streets and Buildings Committee of the Scarborough Corporation have accepted the offer of a piece of a ground, a little over six acres in area, having a frontage on Manor-road, for the sum of £8,500. It will be laid out as a recreation ground.



THE PAVILION, PLAN, BY A. W. N. 1872, 1880.

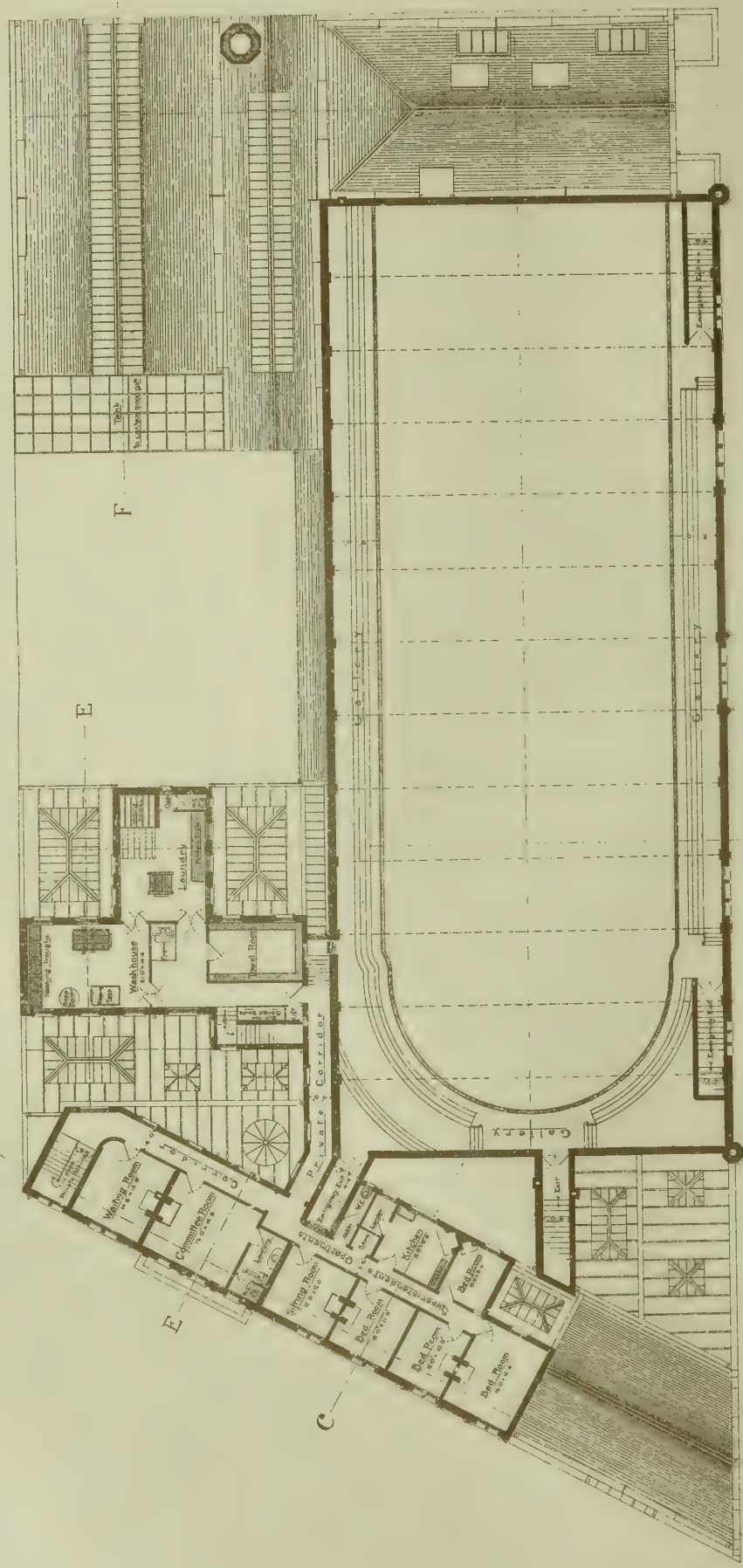

FIRST FLOOR PLAN

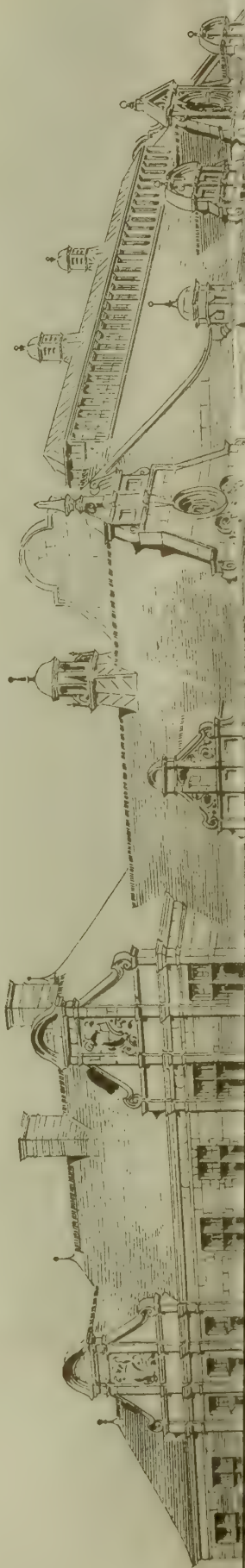





BATTERSEA PUBLIC BATHS. SELECTED DESIGN F J SMITH, ARCHITECT.

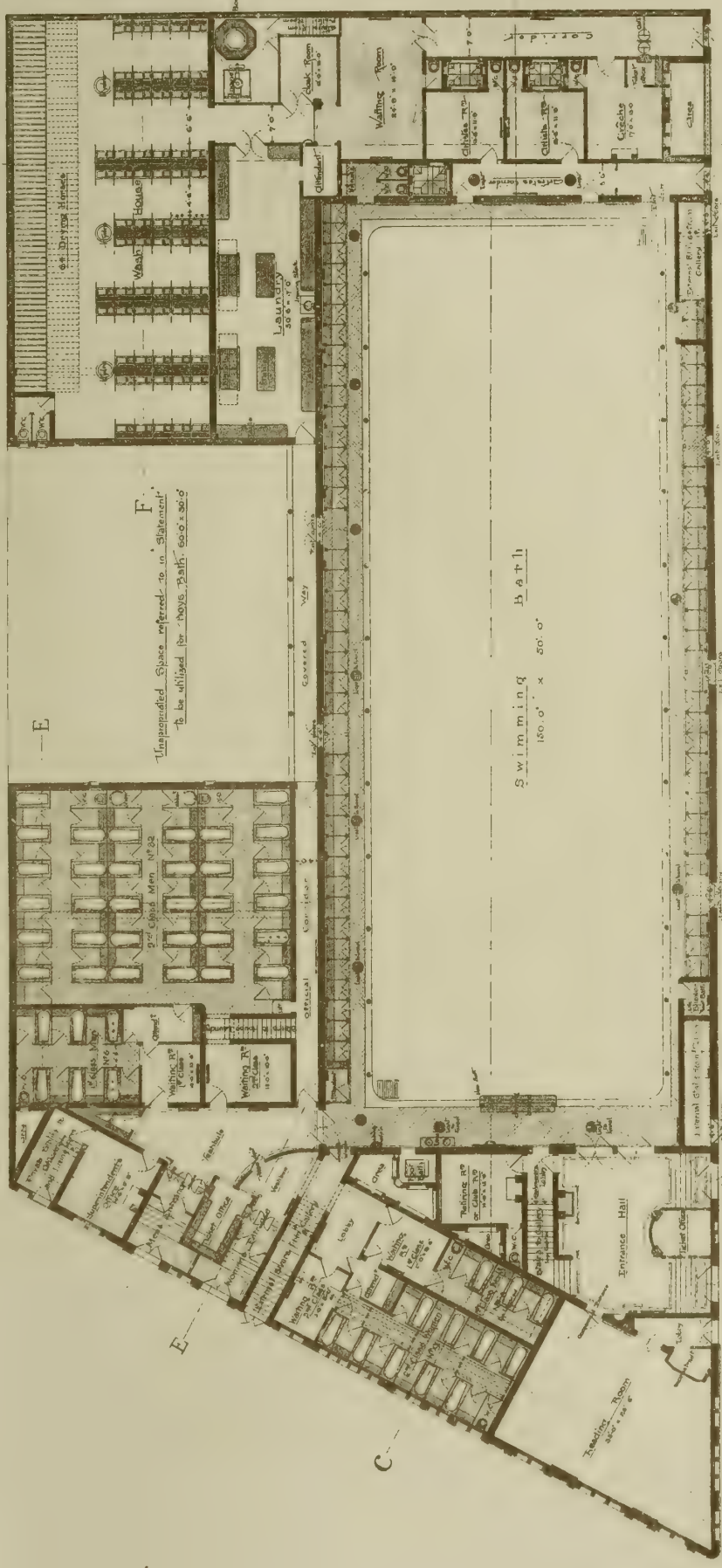

GROUND PLAN



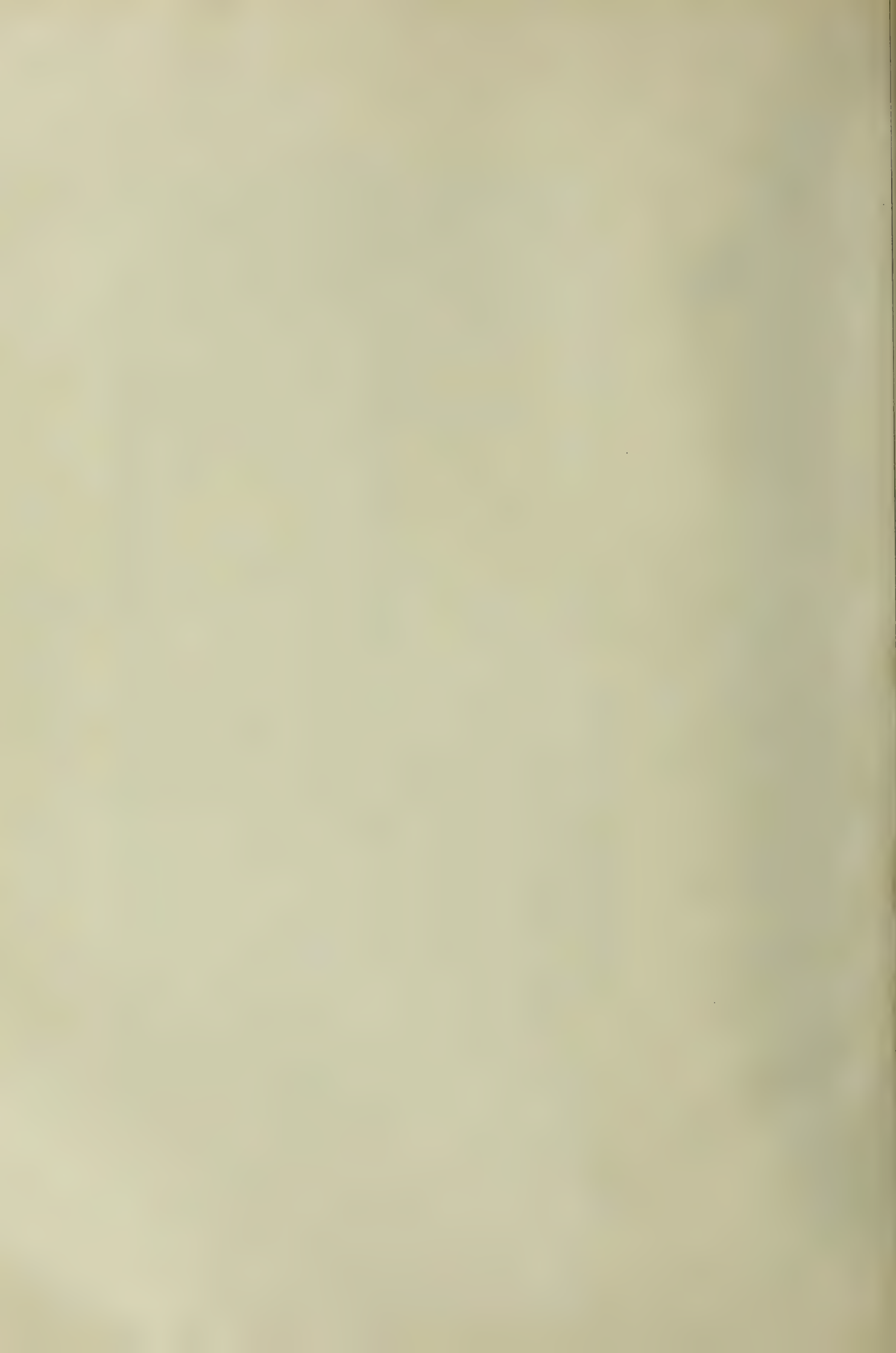





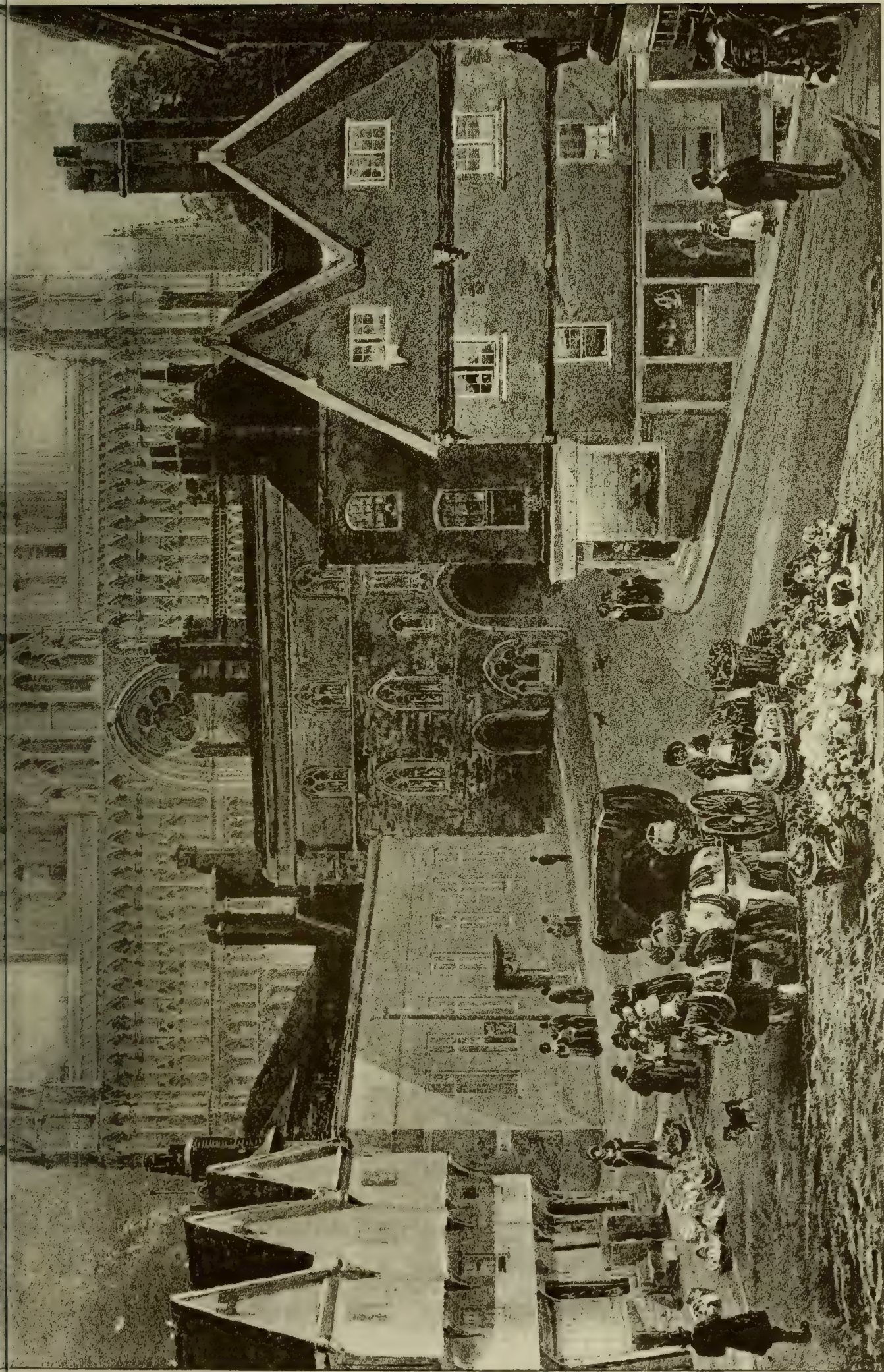

PHOTO-TYPE, by James Akerman, 2, Queen Square, London W.C.

LINCOLN CATHEDRAL BY PETER DE WINT B 1784 D 1849.





• ABBEY MANSIONS.  
for  
• H.M. OFFICE OF WORKS.  
VICTORIA STREET  
WESTMINSTER  
S.W.  
• Chas. & Fowler.  
• Archts.

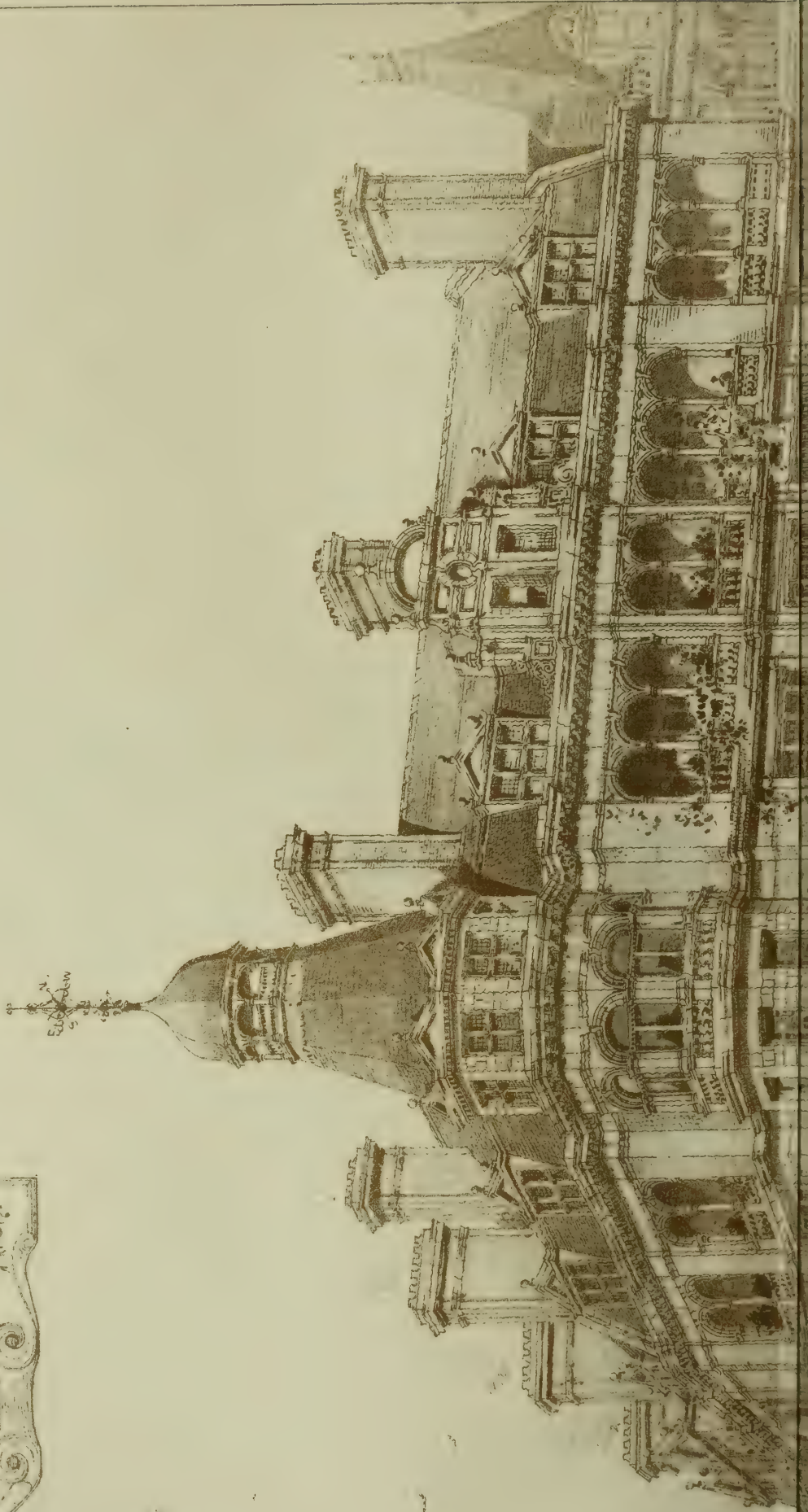



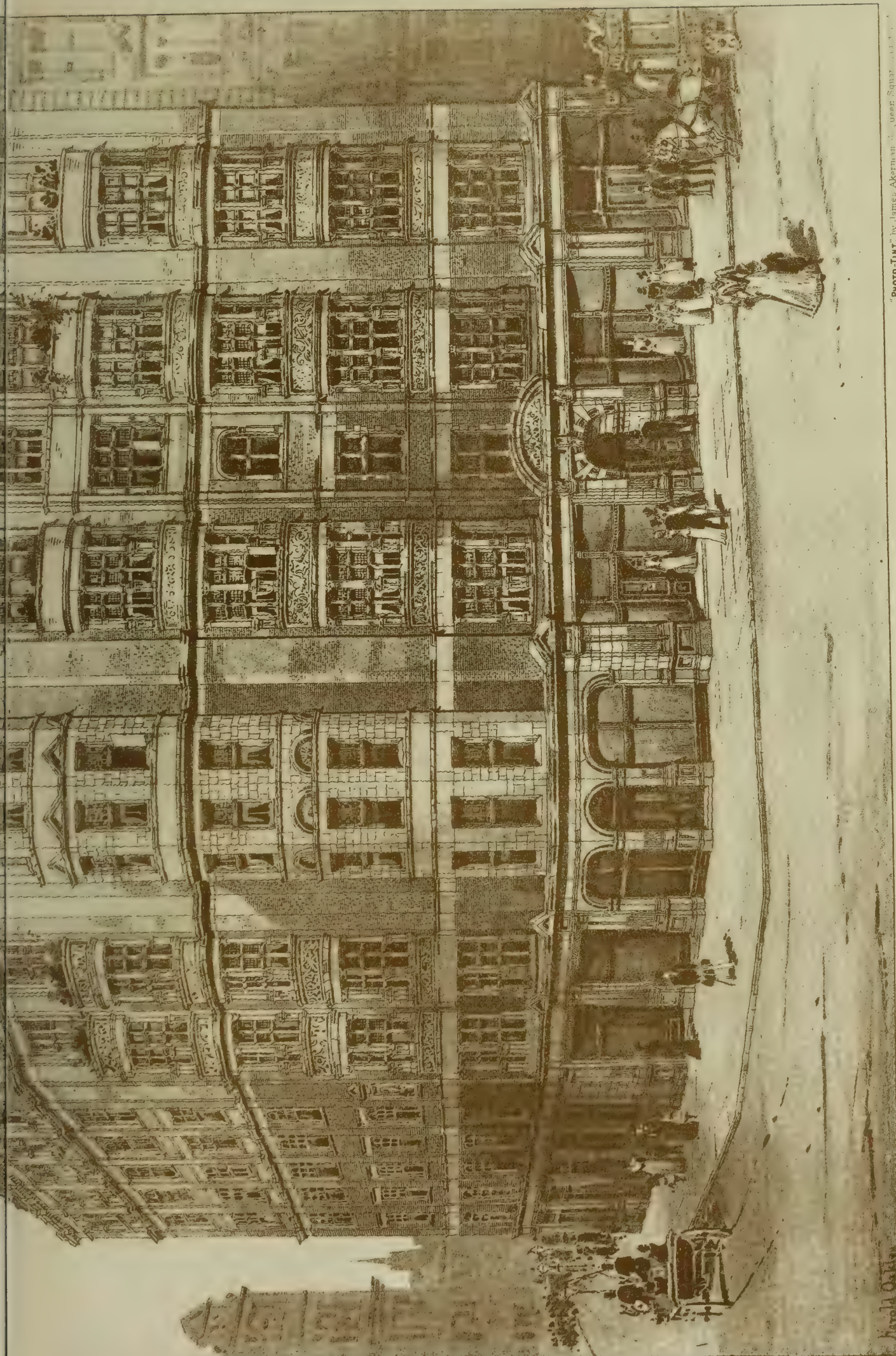
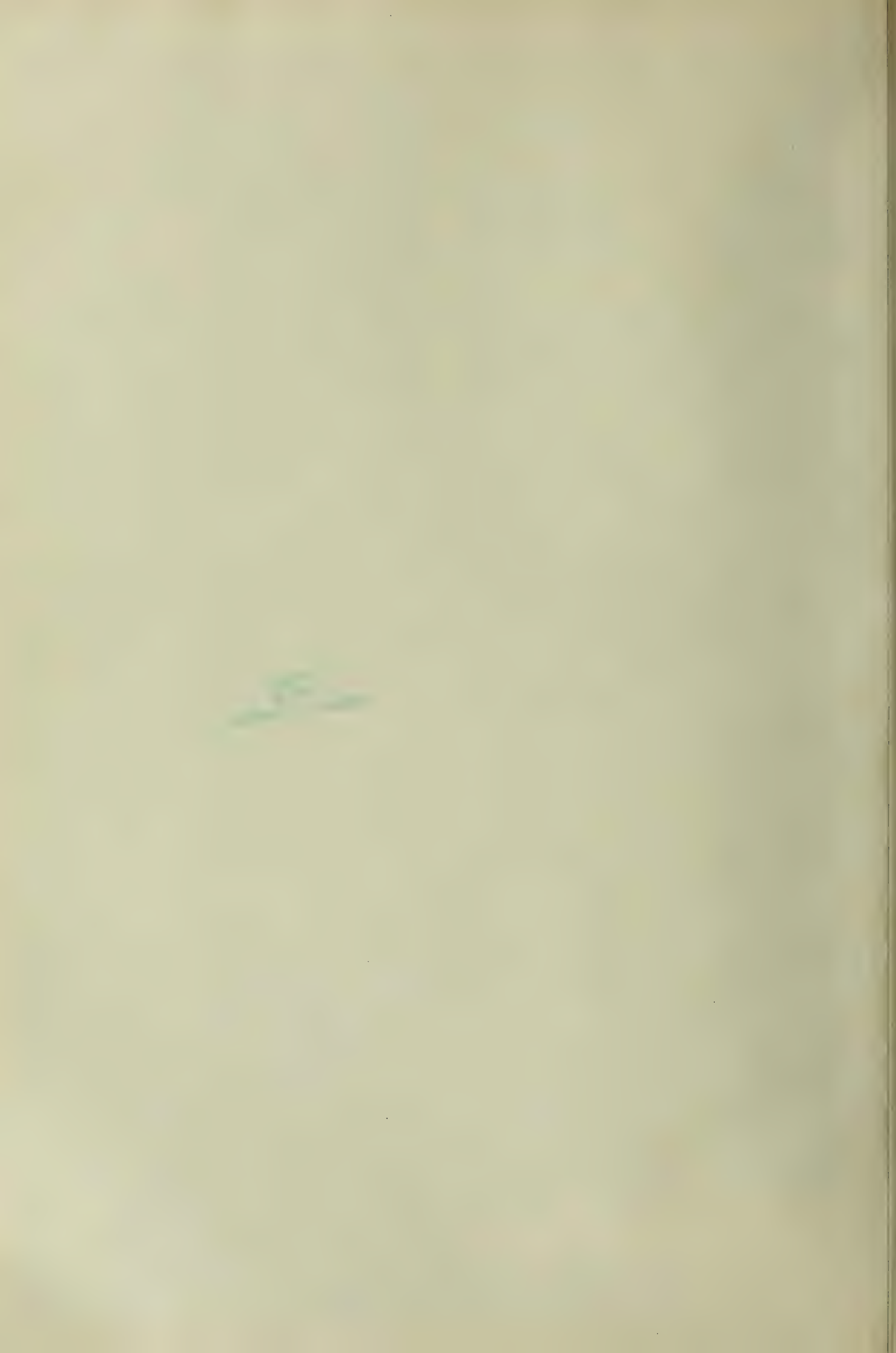
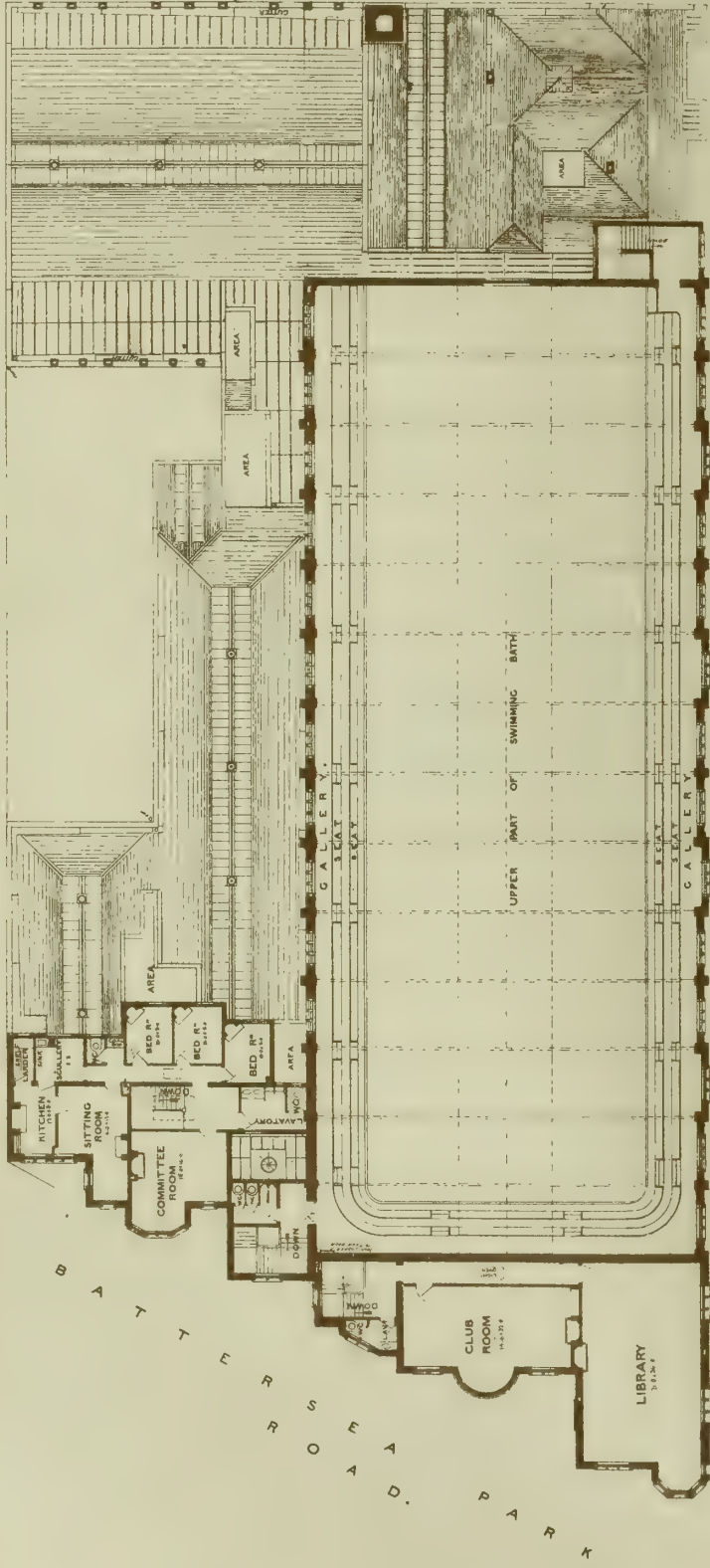

PHOTO-TINT, by James Akerman, N. Queen Street, 1851.

C. Harold Ogden







FIRST FLOOR AND GALLERY

SECOND PREMIATED DESIGN.  
J. HATCHARD SMITH, ARCHITECT.

BATTERSEA PUBLIC BATHS.

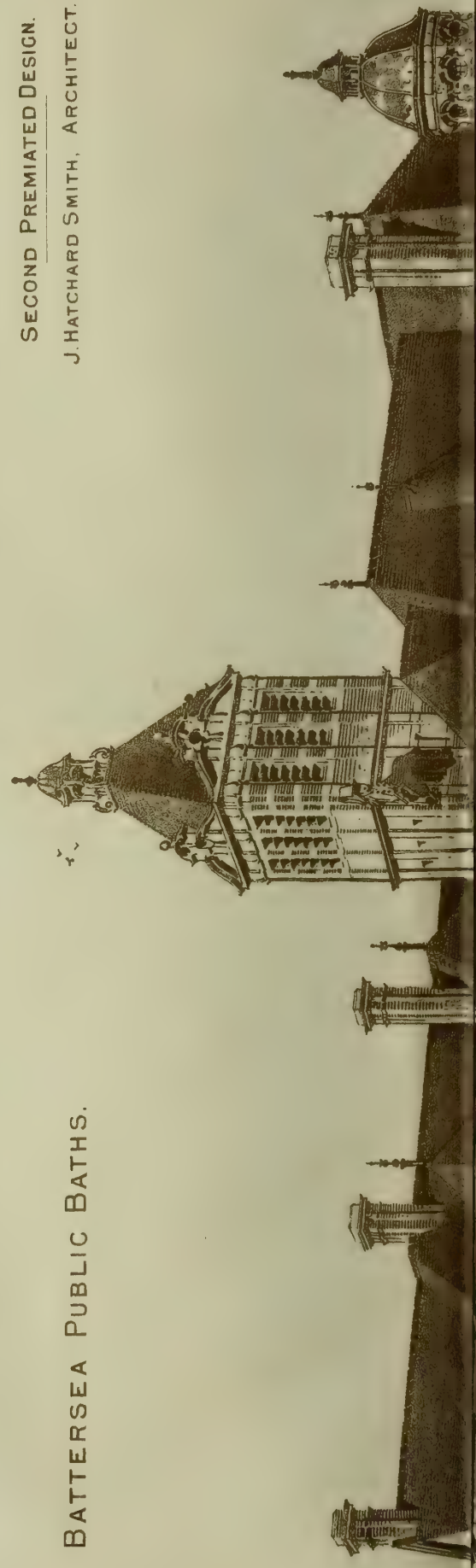

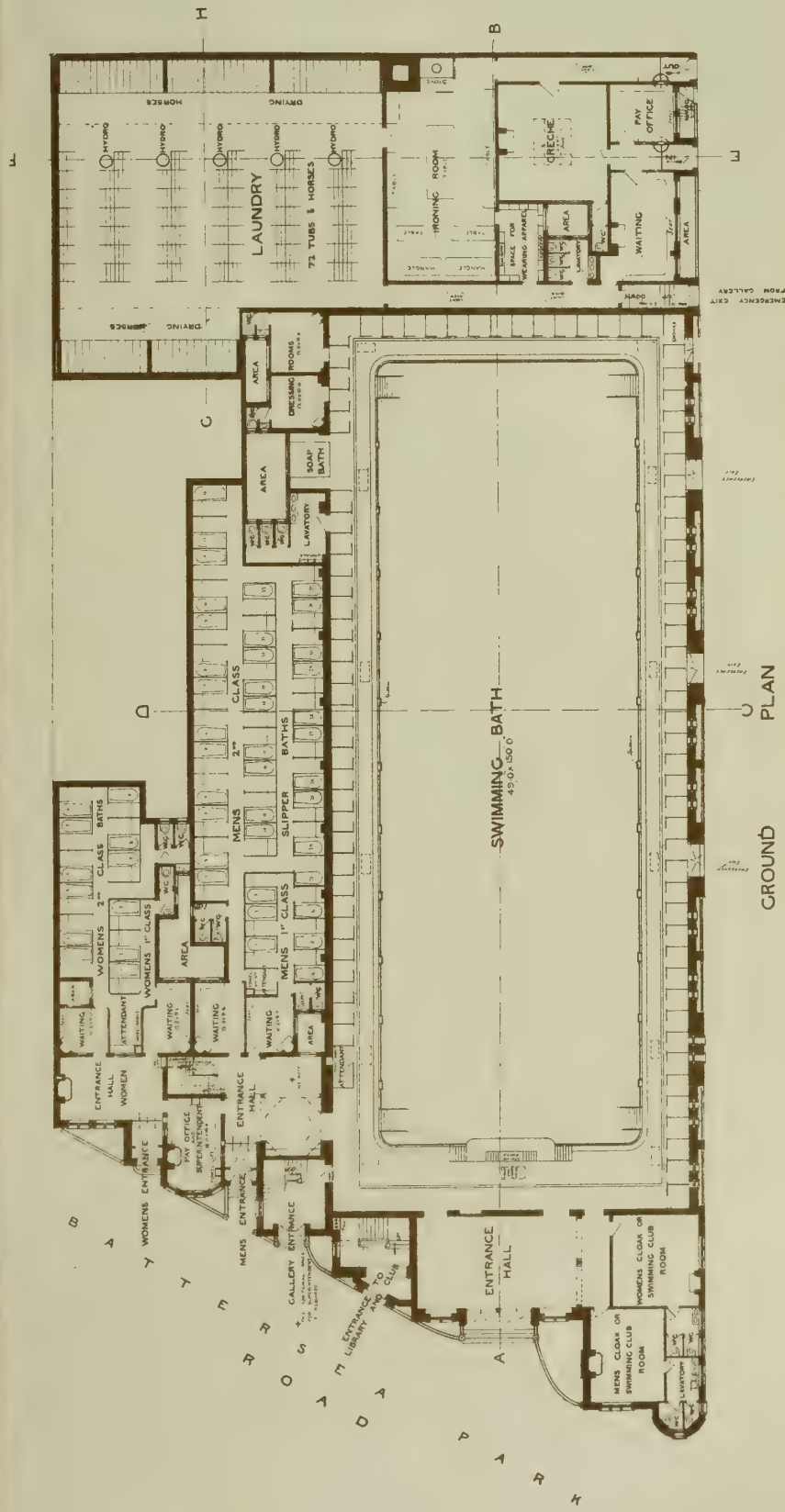
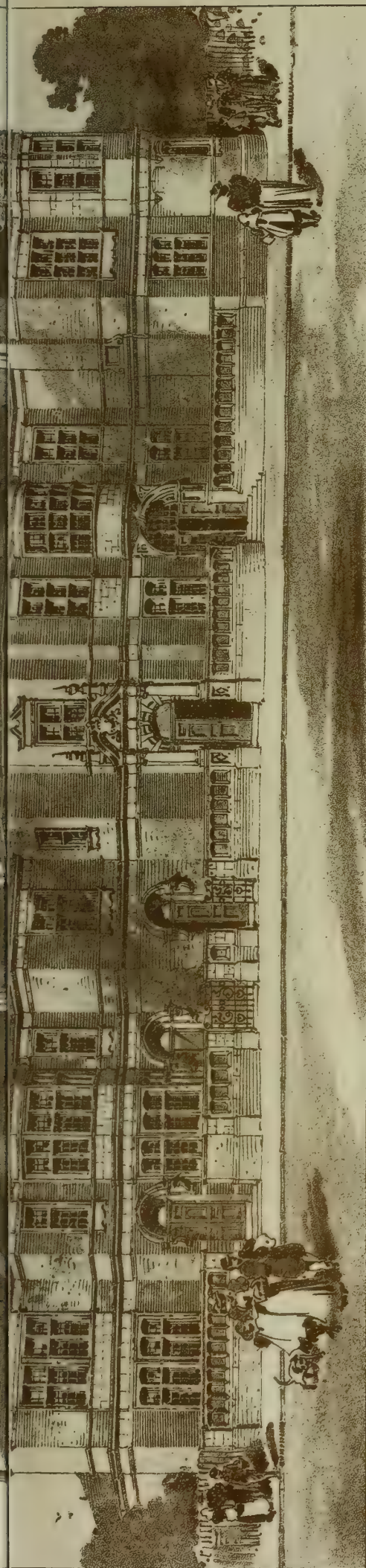

GROUND PLAN

C R I N O L E S T R E E T .

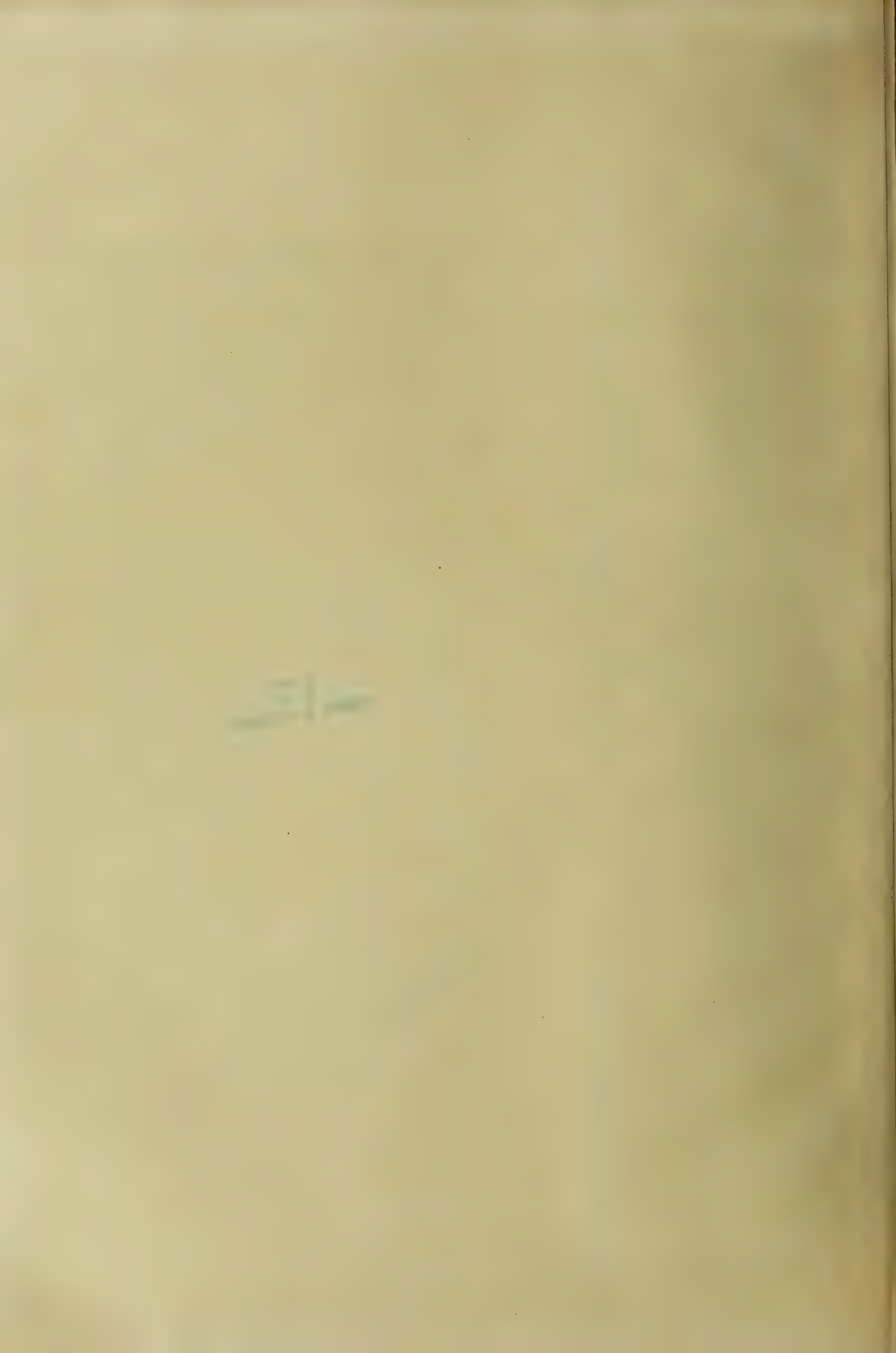

## TO CORRESPONDENTS.

[We do not hold ourselves responsible for the opinions of our correspondents. All communications should be drawn up as briefly as possible, as there are many claimants upon the space allotted to correspondents.]

It is particularly requested that all drawings and all communications respecting illustrations or literary matter should be addressed to the EDITOR of the BUILDING NEWS, 332, Strand, W.C., and not to members of the staff by name. Delay is not unfrequently otherwise caused. All drawings and other communications are sent at contributors' risks, and the Editor will not undertake to pay for, or be liable for, unsought contributions.

Cheques and Post-office Orders to be made payable to THE STRAND NEWSPAPER COMPANY, LIMITED.

## TERMS OF SUBSCRIPTION.

One Pound per annum (post free) to any part of the United Kingdom; for Canada, Nova Scotia, and the United States, £1 6s. 0d. (or 6dols. 30c. gold). To France or Belgium, £1 6s. 0d. (or 33fr. 30c.) To India, £1 6s. 0d. To any of the Australian Colonies or New Zealand, to the Cape, the West Indies, or Natal, £1 6s. 0d.

## ADVERTISEMENT CHARGES.

The charge for Competition and Contract Advertisements, Public Companies, and all official advertisements is 1s. per line of Eight words, the first line counting as two, the minimum charge being 5s. for four lines.

The charge for Auctions, Land Sales, and Miscellaneous and Trade Advertisements (except Situation advertisements) is 6d. per line of Eight words (the first line counting as two), the minimum charge being 4s. 6d. for 40 words. Special terms for series of more than six insertions can be ascertained on application to the Publisher.

Front-page Advertisements 2s. per line, and Paragraph Advertisements 1s. per line. No Front-page or Paragraph Advertisement inserted for less than 5s.

Advertisements for the current week must reach the office not later than 3 p.m. on Thursday. Front-page Advertisements and alterations in serial advertisements must reach the office by Tuesday morning to secure insertion.

## SITUATIONS.

The charge for advertisements for "Situations Vacant" or "Situations Wanted" is ONE SHILLING FOR TWENTY-FOUR WORDS, and Sixpence for every eight words after. All Situation Advertisements must be prepaid.

## NOTICE.

Bound copies of Vol. LXXXIII. are now ready, and should be ordered early (price Twelve Shillings each), as only a limited number are done up. A few bound volumes of Vols. XXXIX., XL., XLI., XLVI., XLIX., LI., LII., LVIII., LIX., LXI., LXII., LXIII., LXIV., LXV., LXVI., LXVII., LXVIII., LXIX., LXX., LXXI., LXXII. may still be had, price Twelve Shillings; all the other bound volumes are out of print. Most of the back numbers of former volumes are, however, to be had singly. Subscribers requiring any back numbers so complete volume just ended should order at once, as many of them soon run out of print.

RECEIVED.—C. W. O.—T. P.—B. W. L.—T. L. and Pow.—S. F. Co.—E. P. R.

## "BUILDING NEWS" DESIGNING CLUB.

RALPH KNOTT.—(We note your approval of our awards. The conditions set forth the accommodation to be provided, and rooms for female nurses were not included. In a men's home of the kind contemplated, such bedrooms are not needed in the ordinary way, and it is better for a nurse to sleep off the premises if she has been on duty.) GOthic JONES.—(We do not limit you to any style for the furniture, but Medieval forms are not so well adapted to present-day uses. Simplicity by all means; but furniture to be good, in the best sense of the word, should be strong and suitable, artistic, and not needlessly costly.)

## Correspondence.

## ORNAMENTAL BRICKWORK: ARCHES.

To the Editor of the BUILDING NEWS.

Sir,—The writer on "Ornamental Brickwork: Arches" (p. 515 of your last issue) gives some very good information so far as it goes; but in treating of the straight camber arch (not, of course, to be confused by your readers with the segmental arch), he slips rather too easily over the subject, merely stating that it "ought to be set out on scientific rules from a face mould, and proper levels obtained for cutting the bricks." That is only partly true, as the rules are not scientific, but to a great extent rule-of-thumb. He does not explain the rule for setting out this apparently most simple of all the arches, but really almost the most difficult. The rules are given in two handbooks published in Weale's Series, but in terms which do not agree, and which assume a possession already by the learner of half the necessary knowledge—perhaps a necessary result of the writers possessing great technical skill in bricklaying without having much literary art. The writer of your article would be doing good service if he undertakes to

supply the omission by explaining clearly how one, not a bricklayer, can set out this arch and prepare the face mould with the levels and lengths marked thereon, so that a bricklayer could cut out the bricks and set them therefrom. Most people other than bricklayers imagine that in this, the straight camber arch, the lines of the joints (including those of the skewbacks) radiate from a centre; but they do not.

In the approximate elliptic arch formed of arcs of circles, the voissors do, of course, radiate from a centre, or centres. I introduce this latter remark, however, only for the purpose of explaining that on a visit to one of the best of our Metropolitan polytechnic classes for practical instruction in drawing, cutting, and setting brick arches, I found in the larger upper arc all the joints radiated to their centre, except those of the key-stone, which were worked to a centre much higher, giving, of course, a much shorter radius; but nobody thought it a defect or of any consequence; it was so set because it came so from the mason, and it was nobody's business to flux the product of the two discordant trades. It was rather considered a creditable thing that the mason's ill-shaped work could be incorporated by the bricklayer, without troubling the mason to correct it.—I am, &c., ARCHITECT.

## CHIPS.

Friday, July 1, has been fixed as the date for the consecration of the new church of St. Peter, now fast approaching completion in the Wightman-road, Hornsey. The Bishop of London will perform the ceremony. The church, which was illustrated by perspective and plan in our issue of May 14, 1897, is being built from designs by Messrs. James Brooks and Son, of Wellington-street, Strand, W.C.

A fountain erected in Market Drayton in commemoration of the 60th anniversary of Her Majesty's reign was formally opened on Monday week. The fountain was designed by Mr. G. A. Craig, surveyor of Market Drayton, and built by Messrs. Harding, of Nantwich. It is constructed of red and grey stone, with marble panels round the base.

Mr. A. E. Prescott (28 years of age), deputy surveyor, Luton, has been appointed surveyor to Douglas Town Council, at a salary of £200 a year.

A proposal is about to be submitted to the shareholders of the Hastings Pier Company for the formation of a winter garden at the north or landward end of the present structure. The plans show a building including a hall capable of holding 4,000 people, provision for a band, and other attractions. The estimated cost is between £30,000 and £40,000.

The Streets and Buildings Committee of the Edinburgh Town Council have agreed to recommend the council to authorise the widening of Stockbridge bridge at a probable cost of £2,400.

The Soldiers' Institute in St. Botolph's-street, Colchester, opened by the late Duke of Albany, has been altered and redecorated to serve as a Liberal clubhouse, and was reopened last (Thursday) night by Sir Edward Grey, M.P. The decorations have been carried out by Mr. Bennell, of Green-street, Colchester.

On Saturday, St. Gregory's Church, at Crackwell, North Riding, was rededicated, after undergoing renovation, at a cost of about £500.

Mr. Frederick Thorpe, deputy gas and water engineer to the Widnes Corporation, has been selected out of 62 candidates to fill the post of engineer and manager of the gasworks at Colne, Lancs, at a salary commencing at £225 per annum. The short list comprised the deputy gas engineers of Bradford, Blackburn, Halifax, Lancaster, Stockport, and Widnes.

Mr. Peter Dollar, A.R.I.B.A., F.S.I., was married on Thursday in last week at Christ Church, Lancaster-gate, to Miss Emily Aja Prince, the second daughter of the late Mr. Joseph Webster Prince, of Brickwood House, Croydon.

An inquiry was held at Barking yesterday (Thursday) by Mr. W. E. O. Mesde-King, an inspector of the Local Government Board, with reference to the application of the Urban District Council of Barking for sanction to borrow £3,250 for the provision of public baths in East-street, Barking, and £15,000 for purposes of electric lighting.

Mr. H. H. Law, an inspector of the Local Government Board, recently held an inquiry respecting an application of the Croydon Town Council for sanction to borrow £40,355 for works of kerbing, channelling, &c.; £1,475 for the further improvement of George-street, £7,000 for the Norbury drainage scheme, £550 for the construction of an outfall sewer at South Norwood, and £500 for the construction of an additional settling tank on South Norwood sewage farm.

## Intercommunication.

## QUESTIONS.

[1934.]—White Efflorescence on Tiles.—Can anyone inform me how to permanently stop white efflorescence (appearing again and again as fast as it is removed) on red tiles, which have now been laid twelve months? These are on a slate balcony some 9ft. off the ground, the slate being floated over with cement and sand to receive them.—PUZZLED.

[1935.]—Architect's Charges.—I shall be greatly obliged for any information on the following:—A client employs an architect to make plans for three dwelling-houses, say twelve rooms each, to be erected on an irregular piece of ground, which the architect has to survey. The plans are approved, and the architect is instructed to prepare specifications for same, which he delivers to the employer with the drawings. The employer, unknown to the architect, puts out the drawings to tender to one builder, who happens to be a relation of the employer himself. The employer comes to the architect some time afterwards and informs him that the tender is too high, and, therefore, he will have others of the plans, but will pay for them, and will send in his account the employer refuses to pay it, and offers one-sixth the amount, which was refused, the charge being based on the amount of the tender at 2½ per cent. Is this charge too high? And, if so, what is the right charge to make for the plans and specifications, no charge having been made for preliminary survey of ground? The employer's argument is, that as he is not making use of the plans, &c., by building from them, he is not bound to pay any per cent. on lowest tender; but only a small sum for time, insisting that the whole of the work could be done in one week.—JUSTICE.

[1936.]—Steep Pitched Hammer-Beam Roof.—I shall be obliged if any of your readers can tell me of any instance of a steep pitched hammer-beam roof, 40ft. span; and, if not, what is the widest span extant, and has it been necessary to put in tie-rods?—INQUIRER.

## REPLIES.

[1933.]—Adjoining Owner.—"Royston" having two adjoining building sites, erects on one a house, and lets it, with the whole of the site, to a tenant, without reservation. He now inquires whether he can enter on the land, the use of which he has sold to his tenant (he has sold its temporary use for the consideration of the rent) for the purpose of pitching a scaffold to enable him to build up to the verge of the remaining plot. Of course he cannot legally do so, nor may he hang a scaffold over his tenant's land, nor drop bricks or mortar on it, or in other way commit a trespass in derogation of his grant of tenancy. What would he himself think, if he had hired the use of a piano, the owner insisted on playing it, or covering it up, or in any other way interfering with his ("Royston's") enjoyment and use of it? "Royston" should have made his proposed building operations the subject of a condition in the agreement of tenancy. I have just heard of these two illustrative cases:—(1) The owner of a row of six small houses with front gardens, sent men who erected a scaffold in the gardens and raked out and repointed the mortar joints of the brickwork fronts. He asked no leave of the tenants. One tenant, who had given notice to quit next quarter-day, objected to the dust and nuisance arising from the work, and brought action against his landlord, who, acting under competent legal advice, settled the matter by a cash payment. (2) Landlord was lessee under covenant with his superior landlord to repair, *inter alia*, the roof. The lessee landlord employed a builder to do so, who erected ladders and got on the roof without the leave of lessee landlord's tenant. Tenant brought action against lessee landlord for trespass, and recovered nominal damages and costs. I am told that costs are always given in such cases, although the damages may be but nominal—as the law favours the maintenance of such rights by action rather than by resort to the forcible removal of the trespasser and his property, which is the desire to reserve any rights to himself to enter during the term for the purpose of repairing the premises, or to do any work to his adjoining properties, he must expressly reserve such right in a written contract of tenancy, as no such right will accrue to him by implication. In the absence of such reservation, the permission of the tenant is necessary.—A. H.

[1933.]—Adjoining Owner.—Unless there is any written agreement to the contrary effect I do not think the tenant can refuse to allow the scaffolding to be erected for the building which abuts, for if such a rule was common, the owner of land would be unable to build on a plot adjoining others they had let. I think owner is within his rights in this case.—ARCHITECT.

The Hoxton Free Library was opened by Sir John Lubbock, M.P., on Wednesday afternoon. The building is in Pitfield-street, and supersedes a temporary one. The cost of the site was £4,500, and that of the building £10,250. Added to these figures must be the cost of the fixtures, furniture, and books. The total cost will exceed £20,000. The architect is Mr. H. T. Hare.

The Bill for establishing a college of forestry at Cornell University, and for placing in its hands for management a tract of thirty thousand acres in the Adirondack Mountains, has been passed by the New York Legislature, and signed by the Governor, and its provisions are to be immediately carried out. The faculty of the college is to consist of a professor, two instructors, a forest manager, and such rangers and superintendents as may be required; and it is provided that the proceeds of timber cut and sold from the college forests shall be paid to the State.

## LEGAL INTELLIGENCE.

**ACTION BY THE BATH CITY ARCHITECT.**—At Bath County-court, on the 14th inst., before his Honour Judge Dundas Gardiner, an action was brought by Major C. E. Davis, F.S.A., the city architect, against the corporation of the city of Bath to recover certain payments for work done by him on behalf of the corporation, and the corporation relied on two agreements made between themselves and a Mrs. Joyce, contending that she was liable to indemnify them against the claim. Mrs. Joyce, the third party to the action, admitted liability to some extent. Mr. Vachell, in opening, said the corporation admitted Major Davis's claim, and therefore the fight was really between the corporation and the third party; £45 was the amount of the claim, and it was for professional charges in connection with the rebuilding of the restaurant which stood at the south-western corner of Cheap-street. Long negotiations took place, during which two agreements were executed, in which Mrs. Joyce agreed to pay Mr. Davis's "reasonable charges." It was upon this that the question hung. Evidence was given on both sides, that for the defence coming from experts like Mr. William V. Gough, vice-president of the Bristol Society of Architects, and Mr. W. L. Bernard, president of the Bristol Society, who spoke as to what they considered fair charges. Defendant had paid £15 15s. into court. His Honour, in giving judgment for her beyond the money in court, with costs, said under the first of the agreements Major Davis claimed £27 10s. for perusing two sets of plans. It seemed to him Major Davis was in a very unfortunate position, because one could see that it was his interest to reject these plans. He was in that awkward position in which a man's interest is opposed to his duty, and he thought it was unfortunate that any gentleman connected with the corporation should be placed in that position. He allowed ten guineas for perusing plans, for which £27 was charged; five guineas for the elevation and detailed drawings, and nothing for passing works on completion.

**MANCHESTER CORPORATION V. PERKINS, GRAHAM, AND CO., LIMITED.**—On Saturday, at the Westminster Palace Hotel, Sir Benjamin Baker had again before him the sensational arbitration case, in which the Manchester Corporation lay charges of fraud against Mr. Perkins, managing director of Messrs. Perkins, Graham, and Co., Limited, contractors, of Manchester and London. The defendant company were the contractors for certain sewers, about 1,800 yards in length, in Deansgate, Manchester, and were to build two rings of brickwork, the inner one of blue brick and the outer of red brick. When the work was completed the corporation officials had it opened up for the purpose of tracing certain extras charged for by the contractors, and then discovered that the outer ring had been left out over almost the entire work. In some places a loose collar of brick had been laid over the inner ring in such a manner that anyone seeing the work in section would suppose it to have been carried out in accordance with the terms of the contract. The defects in the sewers necessitated complete reconstruction, and the Corporation now claimed £12,000 damages against the defendant company. In the course of the evidence it transpired that no record had been kept of the number of bricks supplied, and according to the plaintiff's witnesses the total number was over 235,000 short. The contractors, however, combated this statement, and alleged that the deficiency was certainly not more than 40,000. The defective work was admitted by both parties, and the only question at issue was the sum of money to be paid by the contractors. The defendants estimated that £1,900 should easily reimburse the city council for all work necessarily undertaken, which sum they had paid into court. Evidence was tendered by the plaintiffs to the effect that £5,636 had actually been spent on the work of reconstruction. The contractors did not deny that this might be so; but brought expert witnesses to prove that the corporation had been guilty of gross extravagance, and that the work could have been carried out for £500 according to one witness, for £950 according to another, or for £1,350 according to an estimate made by Mr. Baldwin Latham. Mr. James Perkins, managing director of the defendant company, was called, and declared that he never had a suspicion that the work was being scamped. He made no calculation during the time the work was proceeding as to the number of bricks required. Mr. John Tomlinson, the acting manager, gave similar evidence. At the conclusion of the evidence Mr. Bradbury, who appeared for Mr. Perkins, contended that the plaintiffs had failed to establish the charges of fraud levelled against his client. They had called bricklayers to prove that Mr. Perkins had urged them to scamp the work, but when put into the box they made no such charge. As a matter of fact, the men, who were employed on piecework, had improperly fulfilled their obligations, and had swindled both the corporation and the contractors. At the conclusion of counsels' speeches, the inquiry terminated, Sir Benjamin Baker reserving his decision.

**ALLEGED FRAUDS BY SANITARY TUBE MAKERS AND CORPORATION OFFICIALS.**—At the Manchester City Police-court, on Monday, John Tetlow, a director of Messrs. John Tetlow and Co., sanitary tube manufacturers, Littleborough, and David Hollard, a senior clerk in the Paving Department of the Manchester Corporation, were charged with embezzlement and conspiracy to defraud. The evidence went to show that the firm of which the prisoner Tetlow is a member, had for a number years supplied sanitary tubes and other materials to the corporation, and that by an ingenious system arranged between the two prisoners Tetlow intercepted the monthly accounts sent by the firm to the corporation and substituted others for larger amounts. These substituted accounts, it was alleged, were passed by Hollard, and cheques in respect of them were sent to Messrs. Tetlow. The prisoner Tetlow again is said to have intercepted these remittances, and, paying them into a private account, drew upon that account for the amount due to the firm, which he then paid into Messrs. Tetlow's bank. When arrested, Hollard is said to have admitted that these proceedings had been going on for a number of years, and the money fraudulently obtained had been equally divided. He added that he had received about £30 a month as his share. The prosecution allege that the defalcations amount to about £5,000. The prisoners were committed for trial to the City Sessions, bail to a heavy amount being allowed.

**BLUNDERING OF AN URBAN AUTHORITY.**—At the Flint County-court, on Friday, before his Honour Judge Sir Horatio Lloyd, G. H. Hollingworth, surveyor and mining engineer, of Manchester, and official liquidator of the Bailey Hill Colliery Company, Mold, sued the Rev. W. T. Thomas (Gwenfwrdd), Aafod Alan, Mold, for the sum of £20 for trespass. From the evidence of the plaintiff it appeared that the trespass complained of was caused by the defendant connecting a drain from his property to the main sewer of the Mold Urban District Council, recently constructed at a cost of about £7,000, and which runs through some land belonging to the Bailey Hill Colliery. The plaintiff, in cross-examination, admitted having received the sum of £25 from the Mold Urban Authority for the right of constructing the main sewer through the land; but that did not give the urban authority a right to make any connections with the drain through their land. Mr. Churton, for the defence, said that what the defendant had done had been brought about entirely through the blundering of the Mold Urban District Council, who had served him with notice to connect the drain at this particular spot, and had even gone so far as to threaten legal proceedings against him if it was not done. Under these circumstances the defendant naturally enough took it for granted that the urban authority, in acquiring the right to run the main sewer through this land, had also acquired a right to make connections with the sewer. He, however, found out that this was not so, and immediately he discovered this he communicated with the plaintiff with a view to coming to an amicable arrangement. The plaintiff declined to accept anything less than £20, so the defendant disconnected the drain, and had paid the sum of £1 into court, which, he contended, was ample to cover the trespass committed. His Honour held that the £1 paid into court was quite sufficient to cover the damages; but, as the defendant had not informed the plaintiff that he had disconnected the drain, he could not allow him his costs, so each party would have to bear their own costs. The same plaintiff brought a similar action against the Kesterton Brewery Company, the damages claimed being £10 in this case. The same judgment was given as in the foregoing case.

**THE PRICE OF BRICKS.**—At Lewes County-court on April 12th, before his Honour Judge Martineau, Messrs. Rummery and Sons, brickmakers, of Heathfield, sought to recover from J. W. Hobbs, builder, of Eastbourne, the sum of £23 10s., balance of account for bricks sold and delivered. The whole question was as to the price agreed upon for certain bricks duly delivered. George Rummery said in October of last year he called at a house being built by Mr. Hobbs, and a man named Ticehurst asked him the price of bricks. Witness told him the price was 29s. a thousand in the yard and 39s. a thousand delivered. The house where they were to be delivered was four or five miles from the yard. A day or two afterwards Ticehurst told witness he was to bring the bricks, and accordingly he delivered 13,000, for which he had been paid at the rate of 39s. per thousand. Subsequently he delivered 17,000 bricks, and it was in respect of them that the claim was now made. In cross-examination plaintiff said he never saw Mr. Hobbs himself as to the price of the bricks. Witness did not say his horses were standing idle and he could easily do the carting. He did not know and did not think it likely that kiln bricks, which were worth about 5s. a thousand more than his clamp bricks, could be delivered from Tunbridge Wells for less than he charged. Alfred Edmund Rummery, a nephew of the plaintiff, proved that the first 13,000 bricks were duly paid for by cheque at the rate of 39s. a thou-

sand. That was a fair and reasonable price. Frederick Richard Parris, builder, of Heathfield, said the price of bricks last year was from 25s. to 29s. a thousand in the yard, and went up to 39s. a thousand outside. Cross-examined; The brick produced, delivered by another Heathfield maker at 38s. a thousand, was superior, he should think, to plaintiff's at 39s. Harry Burcham Overham, proprietor of a brickyard at Horeham-road, did not think that 29s. in the yard was an excessive price for the time of year. For defendant: Wm. Herbert, foreman, employed by Mr. Hobbs, said plaintiff showed him some bricks, and said the price was 29s. a thousand, delivered. Next day plaintiff came again, and in witness's presence said the price was 29s. a thousand, delivered. Mr. Hobbs told him about 30,000 would be wanted. Ticehurst never had authority to order bricks. Cross-examined, witness said Rummery was wrong when he said he never saw Mr. Hobbs as to the price of the bricks. James William Hobbs said in October he was building a house at Heathfield, and he asked the last witness to ascertain the price of bricks. Next day Mr. Rummery came and said he would deliver the bricks at 29s. Some time afterwards plaintiff asked him for a cheque on account, and witness sent him one for £10 10s. Again he sent a cheque for £15 7s., simply as payment on account of bricks. In January, when witness received received Rummery's account to date, he wrote back that some mistake had been made, as the price was 29s., not 39s. To this Rummery replied that they had made no mistake, and they had paid 10s. a thousand for the cartage. Witness was manager for Messrs. Pearce and Co.; but this house was a private one, which he had permission from his employers to build. Charles Edward Hobbs, brother of the last witness, said he was responsible for the cheque for £15 7s. being sent on to the plaintiff. His Honour said his experience was that builders did not usually pay more than was due. He believed the whole case had arisen out of a certain amount of carelessness when the price was agreed upon. He gave judgment for the plaintiff.

**TEMPORARY STRUCTURES IN FORECOURTS.**—At the Brighton police-court, on Friday, Moses Lee was summoned by the corporation (1) for erecting, on Nov. 12, 1897, a new building on the forecourt in front of No. 33, Kensington-gardens, beyond the line of frontage prescribed by the town council on Oct. 31, 1895, and (2) for erecting a new building on the forecourt of No. 33, Kensington-gardens, without delivering to the borough surveyor a block plan and detailed plans and sections of the said building. Mr. Talbot prosecuted on behalf of the corporation. Defendant put in a formal plea of not guilty. Alfred Weller, deputy borough surveyor, said he had seen a structure in the forecourt of Kensington-gardens. It was of a temporary character, about 11ft. long, 11ft. 6in. wide, and 8ft. in depth. There were six uprights and three rafters, the structure being to support tarpaulin or canvas. Inside the structure there was a stall for displaying goods. No plan had been submitted to the borough surveyor in respect of this building, nor had notice been given of intention to erect the building. Mr. Talbot said he would withdraw the summons if defendant would pull the structure down and pay the costs. Defendant agreed to do this, and the case was therefore adjourned.

**LANDS CLAUSES CONSOLIDATION ACT, SECTION 92.**—In the Court of Appeal, before the Master of the Rolls and Lords Justices Rigby and Collins, an appeal was heard on Tuesday, "Allhusen v. the Ealing and South Harrow Railway Company." The defendant company desired to purchase, for the purpose of making their railway, a small portion of a private road forming the approach to a house known as Twyford Abbey, belonging to the plaintiff and appellant, and the question at issue was whether they could be compelled to take the whole of the property. Mr. Justice Stirling, before whom the case came in the first instance, on March 22nd, decided that they could not; and their Lordships now upheld his decision, and dismissed the appeal, with costs.

**RE BERNARD JOSEPH GREEN.**—In this case, that of an architect and surveyor practising at Walpole-street, Wolverhampton, according to Official Receiver's statement, the liabilities are estimated at £235 8s. 6d., and the assets nil. The debtor was formerly in the Royal Engineers. He returned to Wolverhampton in 1892, and after assisting his father, the late Mr. W. A. Green, for a time, he commenced business as an architect and surveyor, without capital. It had never been successful, and in 1895 a distress was levied under which all his furniture was sold. He attributes his insolvency to want of capital, competition, and bad trade.

An alabaster reredos and brass altar rails have been placed in the chancel at the Seamen's Orphanage Chapel, Newsham Park, Liverpool, as a memorial. They were designed and executed by Messrs. Norbury, Paterson, and Co., of Myrtle-street, Liverpool.



## PARLIAMENTARY NOTES.

**THE LONDON BUILDING ACT (1894) AMENDMENT BILL.**—In connection with the consideration of this Bill in Committee, the adjourned debate on the question, "That it be an instruction to the committee to take into consideration whether the offices and buildings of the Stock Exchange shall be exempted from the operations of Parts VI. and VII. of the principal Act," was resumed on Monday night. Mr. Pickersgill said that the statement that the London County Council did not object to this instruction was misleading. Neither the County Council nor its Parliamentary committee had had the instruction under consideration. The members of the Stock Exchange desired to have their offices and buildings exempted from Parts VI. and VII. of the principal Act. The main object of Part VI. was to lay down in regard to the construction of buildings certain conditions which were for the general advantage; and to exempt the Stock Exchange would be most unfair. If the Stock Exchange had a *locus* before the committee, they could submit their case; and, if they had not, why should the House of Commons specially interfere on their behalf? One section (75) of the principal Act might press hardly on the Stock Exchange. That body wished to make certain extensions of their premises; and section 75 prohibited buildings from exceeding certain dimensions without having party-walls. The power of exemption which was given to the London County Council was limited in a manner that would exclude the Stock Exchange; and therefore, as a compromise, he should move to leave out from the instruction the words "Parts VI. and VII.," and substitute the words "Section 75." Mr. Brigg seconded the amendment. Mr. Cohen said that, while it was true that the County Council had not assented to the instruction, approval had been notified by the special members of the Parliamentary committee to whom the question had been referred by the whole committee. The Stock Exchange did not claim to be exempted from the general law by this instruction; they only asked that the committee on the Bill might consider whether they were entitled to this exemption. The House divided, and the numbers were: For the instruction, 64; against, 46; majority, 18. The instruction was therefore carried.

Mr. Passmore Edwards is about to erect a public free library for Acton, on a fine site in the High-road, and Mr. Maurice B. Adams, F.R.I.B.A., has been appointed the architect.

Mr. W. W. E. Fletcher, M.B., Local Government Board inspector, was present at the Municipal Buildings, Dale-street, Liverpool, on Tuesday, to inquire into the circumstances attendant upon the application of the Liverpool City Council for sanction to borrow £38,000 for the purchase of a site at Fazakerley for an infectious diseases hospital.

Additions are being made to Northey-street Board School, Limehouse, and special consideration has been given to the ventilation, which will be effected on the Boyle system.

The municipal buildings committee of Glasgow Corporation had under consideration on Tuesday the decoration of the Banqueting Hall. It was decided that the three centre panels should be painted by Mr. James Lavery, R.S.A., Mr. Alexander Roche, A.R.S.A., and Mr. E. A. Walton, A.R.S.A.; and the lunette above the platform by Mr. George Henry, A.R.S.A. The pictures will be illustrative of incidents in the history of the city. Each artist will receive a fee of 500 guineas.

A fire broke out early on Monday morning in the saw-mills at Troon Harbour, whereby the whole buildings, machinery, and stock, including several thousands of sleepers saturated with creosote, were destroyed. The mills are owned by Messrs. Calder and Son, Glasgow, and the damage is estimated at between £10,000 and £12,000.

The Princess of Wales has consented to open the new Laboratories of the London School of Medicine for Women in Handel-street, Brunswick-square, next July.

Messrs. Doulton, of Lambeth, London, the well-known potters and sanitary engineers, have removed their Manchester depot to Temple Chambers, St. James's-square, Manchester, where they have opened commodious showrooms for the display of their manufactures. This change in address has been caused by the large increase in the local demand for their productions. Prominent in their showrooms is a fine display of glazed faience fireplaces and mantels, showing a variety of beautiful designs and colours. Amongst the sanitary fittings is a fine display of baths of the most modern style of design. Specially noticeable are the vitreous enamelled baths, lavatories of a great variety and form. Urinals and slop-sinks are a leading feature in these showrooms. A variety of the manufactures are shown, which are all of the high-class nature associated with this firm. Architects and others connected with the building trade will find such showrooms as these of great service to them.

## WATER SUPPLY AND SANITARY MATTERS.

**SHEFFIELD.**—CLEARING AWAY AN INSANITARY AREA.—The corporation of Sheffield, although actively engaged in widening leading thoroughfares, providing electric tramways, and in laying-out and beautifying parks and woods and recreation grounds, are also giving attention, says the *Leeds Mercury*, to the improving out of existence of some of the worst slums and alleys in the city. Some years ago, the whole of the property in the very heart of Sheffield, and covering an area of 2,398 square yards, was condemned as insanitary and unfit for people to dwell in. The houses are occupied by the very poorest and most destitute of the inhabitants. The average death-rate of the city during the last ten years has been 21 per 1,000; in the condemned area it has been, in the same period, 31 per 1,000. The Local Government Board were approached by the corporation and sanction obtained to the clearing of the entire area, and the carrying through it of two wide streets. That arrangement divides the area into three sections, and one section has to be cleared and cottages rebuilt before another is touched. The city surveyor estimated that the cost of the buildings and land would be £72,424, and the formation of new streets, &c., £8,498; total, £80,922. He estimated that the surplus land, after laying out the new streets, would be worth £21,250, on which sufficient house accommodation has to be provided for 750 people. The corporation had to come to terms with 62 different owners, and they have done so with the exception of four, at a cost of £86,814. The estimate has, therefore, already been exceeded by £5,892, and there are four more plots to buy. The work of clearing the first section, on which there are about 250 houses, including three public-houses, will be commenced almost immediately. If built according to the requirements of the Local Government Board it will not be possible to let the new houses for less rents than from 5s. 6d. to 6s. 6d. per week. The alternative under consideration by the corporation is to erect flats.

A new theatre is about to be built at Govan, a little to the west of Govan Cross. The theatre will have a frontage of 70ft. to Govan-road, and another of 160ft. to M'Kechnie-street. The main entrance will be situated in Govan-road, and will be surmounted by a round tower 119ft. high; while the gallery exits will lead into M'Kechnie-street. Accommodation will be provided for an audience of 3,130. The estimated cost of the building is £10,000.

A crowded meeting was held at Rugeley, on Thursday night in last week, to consider the proposals for the erection of a new parish church. The vicar stated that the amount of subscriptions promised and given was £2,444. The Hopkins bequest amounted to £3,526, and if this money could be obtained they would have about £6,000 towards the erection of a new church. The feeling of the meeting was taken upon the question whether the new church should be erected upon the site of the ancient parish church, of which only the chancel remains, or in a more central position, and there was a majority of 15 in favour of the latter. A committee was accordingly formed to report upon a suitable site, the one most in favour being that upon which the present mission church stands.

In the case of the application for discharge from bankruptcy by Charley Mallinson, trading with Ebenezer Thorpe as Thorpe and Mallinson, Holmfirth, builder and stone merchant, the discharge has been suspended for one month, ending April 18, 1898. In that of Walter Atkin Skinner, Wadhurst, builder, the discharge has been suspended for two years, ending March 16, 1900.

Two windows have just been filled with stained glass in the north choir aisle of Truro Cathedral. The subject forms links in the historic series, illustrating the progress of the church, designed for the cathedral. In the eastern light are represented three martyrs of the Early church, St. Cyprian, Bishop of Carthage, St. Perpetua, and St. Lawrence, the great Archdeacon of Rome. On the predella is represented the scene of St. Cyprian's martyrdom. The northern window contains figures of St. Pancras, St. Alban, and St. Katharine. All the windows in the north aisle of the cathedral, with the exception of a single light, are now filled with stained glass.

In view of the adjacent works now in progress in connection with the construction of the Central London Railway, and the subways in front of the Mansion House, an examination has been made as to the effect (if any) of these operations on the stability of the Mansion House itself, with the result that no cause of danger or alarm exists. The annual works of reparation and renovation, recently in progress and now completed, would in the ordinary course have taken place at the close of the last mayoralty, but were postponed till the Easter vacation for the convenience of the Lord Mayor. Mr. Andrew Murray, the City surveyor, states emphatically that no ground exists for the alarmist statements recently promulgated.

## STAINED GLASS.

**COPENHAGEN.**—At St. Alban's English Church, on Sunday, the stained-glass window subscribed for by British residents in Denmark as a memorial of the 60 years' reign of Queen Victoria, was unveiled by the British Minister, Sir Charles Scott. The subject of the window is "The Home in Bethany." The Royal monogram is introduced in the cinquefoil, and the Royal arms, with the dates 1837 and 1897, are inscribed on scrolls at the foot of the window. Another window, filled with stained glass in memory of Professor and Mrs. Stephens, was unveiled at the same time. The subject of this window is "Bearing the Cross." Dr. George Stephens was Professor of the English Language and Literature in the University of Copenhagen during 42 years, and was regarded as the first Runic scholar in Europe. A small balance remaining after paying the expenses of the Jubilee window has been utilised for placing a second coloured window in the church porch. The three windows have been designed and executed by Messrs. Heaton, Butler, and Bayne, of London, under the supervision of Sir Arthur W. Blomfield, A.R.A., the architect of the church.

## CHIPS.

The Primitive Methodist new Sunday-schools erected in Kirkland-street, St. Helen's, at a total cost of about £1,500, were opened on Thursday in last week. The premises have been built on the site of the old chapel, and have a frontage of Ruabon bricks, with terracotta enrichments and red stone dressings. The main hall is 52ft. by 31ft. There are twelve classrooms. The whole of the work has been carried out by Mr. Joseph Ellison, builder and decorator, of St. Helen's, from designs prepared by Mr. John Wilson, architect, of Runcorn.

At the last meeting of the Coventry Trades and Labour Council the president announced that photographs were being taken of slum property in various parts of the city, and, as a contrast, others of the houses of the owners, for the purpose of a magisterial lecture in the autumn, at which information would be supplied as to rent of the slum dwellings, number of inmates, &c.

A bust of the late Mr. J. F. B. Firth, the first deputy chairman of the County Council, has been presented to the Chelsea Public Library by Miss Mary Grant, sculptor, of Tite-street, Chelsea. Mr. Firth was from 1876 to 1879 a member of the Chelsea division of the School Board for London, and M.P. for Chelsea from April, 1880, to November, 1885.

The Sunday-schools attached to the Ebenezer Methodist New Connection Chapel, Newcastle-under-Lyne, are being rebuilt from plans by Mr. J. Lewis, architect, Newcastle. The girls' school will comprise seven classrooms, accommodating 245 scholars, and on the site of the lecture-hall a boys' school, also containing seven classrooms, and capable of accommodating nearly 190 children, will be constructed. Above this room will be a lecture-hall seating 400 persons. Mr. J. Bagnall, of Fenton, has taken the building contract for £1,300.

The city council of Canterbury have adopted plans by Mr. A. J. Jennings, of that city, for providing a lunatic asylum accommodating 200 pauper patients and 50 private patients. They have appointed Mr. Jennings as architect at a remuneration of 5 per cent on the actual cost, but in no way to exceed that percentage on the estimated cost, £60,000. The site will cost an additional £10,000.

The Directors of the Maidstone Waterworks Company have decided to vote £3,000 to be divided among those sufferers from the recent typhoid epidemic in the borough who have received no pecuniary or other help from the relief committee, and who had threatened to bring a combined action against them. The claimants have accepted the offer of the directors.

The parish church of Manafon was reopened on Wednesday week after repairs and renovation. The walls have been repaired, new floors laid, the entire church re-seated in oak, and new heating apparatus, lych-gate, eagle lectern, and chancel screen provided. The work of restoration has been carried out by Messrs. J. Ward and Sons, Uttoxeter, under the superintendence of Messrs. Douglas and Minshull, architects, Chester.

A strong feeling has been manifested throughout Lincolnshire lately against the proposal to erect a stained-glass window in Lincoln Cathedral in memory of the late Poet Laureate, on the ground that such a memorial would be totally inadequate. At a meeting of the committee the proposal has been abandoned, and instead it has been decided to erect a statue of Lord Tennyson in Lincoln.

The new public baths and washhouses for Deptford, built at a cost of £40,000, were opened by the Lord Mayor on Wednesday. Mr. Thomas Dinwiddy is the architect, and Mr. H. L. Holloway the builder. We illustrated the building, which faces New Cross-road and Laurie-street, in our issue of Oct. 18, 1896.

## Our Office Table.

THE Metropolitan Tabernacle in Newington Butts, which was reduced to roofless walls by the disastrous fire of Wednesday afternoon, was built between 1859 and 1861 from plans by Mr. W. Wilmer Pockock, who is now the senior Fellow of the Royal Institute of British Architects. The contractor was the late Mr. William Higgs, and the cost, apart from special gifts, was £31,000, all of which was raised by the opening day. The building was only insured for £12,000. In the area and two galleries seats were provided for nearly 5,000 persons, it being the largest Non-conformist chapel in the United Kingdom. There was no heating apparatus, as such, ever placed in the chapel, the late pastor having had, it is said, a strong objection to any such arrangement, so that the only source of fire was the part of the basement used on this occasion for cooking. The fire, which is attributed to the overheating of a kitchen flue, broke out in the south-east corner of the upper gallery, and owing to the large amount of timber employed in construction spread with great rapidity. The church records and valuable portraits were fortunately saved. It is announced that no time will be lost in reconstructing the building. The site is a freehold one, having been purchased from the Fishmongers' Company, whose almshouses previously stood thereon.

ARRANGEMENTS have been made for holding at the South London Art Gallery (Lord Leighton Memorial), Peckham-road, S.E., a series of special collections, of which the first, to be opened to-morrow, will be a collection of Japanese colour prints, with a demonstration by Mr. Morley Fletcher on the methods of printing in colour from wood blocks. The gallery is open from 2 p.m. to 10 p.m. on week days, and from 3 p.m. to 9 p.m. on Sundays. The ordinary collection is, in a sense, "permanent," though, as the pictures shown are mostly lent, they are continually changing. It is thus quite distinct from the short loan exhibitions held in various parts of London at this time. In addition to the picture gallery there is a museum filled with technical objects of artistic interest.

UNDER the title of "Ancient Southampton," a most interesting exhibition of works of art illustrative of ancient Southampton has been opened at the Philharmonic Hall, of that town, by Mr. William Burrough Hill, F.S.I. This gentleman has generously thrown open his collection free to anyone on the presentation of his card. The catalogue we have received shows the extent and variety of this collection, and is an admirable incentive to others to collect and exhibit when occasion requires any interesting pictures, drawings, or etchings of their native town. There are 228 works that have been hung, including a valuable collection of oil-paintings, water-colour, and pencil drawings by a well-known artist, J. G. Hart; water-colours by W. A. Cooper; several interesting engravings by the late Philip Brannon. Works by Tobias Young, William Strayensen, and David Low are also to be found in the collection. We wish Mr. Burrough Hill every success in his praiseworthy attempt to maintain the landmarks of this ancient town, which are unhappily fast disappearing. In this way alone can we hope to preserve the records of old towns which are now under the remorseless grip of the speculative builder and land-grabber. It would have added to the value of the catalogue if the dates when the drawings were executed had been given.

SOME interesting figures are given in the April number of the *Labour Gazette* as to the number of urban sanitary districts in which the contracts entered into by the local authority for the execution of works specify any conditions as to the wages to be paid by the contractor, or other conditions with respect to the persons employed by him. If London is added, the whole of the urban districts in England and Wales may be divided into two groups, of which the first, with an aggregate population of about 13,000,000, includes all districts in which the local authorities impose conditions of some kind as to wages in their contracts; and the second, with a population of about 8,000,000, includes all districts in which such conditions are absent.

THE spring meeting of the Iron and Steel Institute will be held in London at the Institution of Civil Engineers on Thursday and Friday, May 5 and 6, under the presidency of Mr. Edward P.

Martin, of Dowlais. The Bessemer gold medal will, in accordance with a wish expressed by the late Sir Henry Bessemer, be awarded to Mr. R. Price-Williams in recognition of the active part he took in the early days of the use of steel on railways. Mr. A. Greiner, director-general of Cockerill's works in Belgium, will give an account of his experience of the use of blast-furnace gases as motive power. Mr. Charles Cochran will read a paper on blast-furnace practice, showing that with ore containing 2 per cent. less iron, and with coke containing 2 per cent. more ash, he is working with as great economy as he did 15 years ago with better material. Mr. J. H. Darby will deal with coking in by-product ovens, Mr. F. Radcliffe with steel forging, Mr. R. Price-Williams with steel permanent way, and Mr. H. Bauerman with the iron industry of the Urals. Other papers are promised by Mr. J. E. Stead, Mr. C. H. Ridsdale, Mr. E. H. Saniter, and the Austrian metallurgist Baron Jüptner von Jörnstorff.

THERE would seem to be a fair prospect for the use of wood-pulp in floor cloth in the near future. Perfect success has not yet been obtained; but those who have it in hand seem to be pretty sanguine of the result of their labours. As to taking colour, the patterns as yet obtained in shades of pale grey up to dark olive worked out in diamonds; but probably any number of tints may be retained on the wooden surface—when the composition of the fabric is perfected.

EXCAVATIONS are in progress in Ephesus, under Dr. Rudoff Heberdey, of Vienna. A theatre of the Roman period has been laid open having an auditorium of three rows of seats and an orchestra. A well-house of Ionic style in its neighbourhood had a fountain adorned with lions' heads as its waterspouts. In the rubbish with which the well-house was choked the workmen found masses of earthenware lamps, fragments of terra-sigillata, a statue of Nemesis, and a griffin. Traces of magnificent buildings of the year 263 before Christ have also been discovered.

The chapel in the north transept of Ely Cathedral which has been fitted up for private prayer by Canon Stanton, was dedicated on Easter Tuesday. It has been provided with a reredos designed by Mr. J. A. Reeve, and executed by Messrs. Farmer and Brindley; the subject is Our Lord as High Priest and Redeemer. The screen which stood here till the repaving of the north transept in 1876 has been replaced; it is, probably (except the top), of the 14th century.

The estates of Redland Lodge and Redland Knoll, Bristol, properties adjoining each other and close to the border of Durham Down, were, owing to the deaths of their former owners, recently sold, and the purchaser has laid out the land, about nine acres in all, for building a superior class of residences. Four roads called Belvidere-road, Blenheim-road, The Quadrant, and The Glen are in course of formation, and the district will be known as Redland-gardens. Mains will connect the civic electrical supply with the new roads, which are being constructed, under the direction of Mr. Herbert F. Jones, architect, of Bridge-street, Bristol.

The Rev. W. L. Watkinson, president of the Wesleyan Conference, formally opened a new Wesleyan school chapel in Market-street, Holyoake, to take the place of the old chapel situated at the far end of the village, and built some 40 years ago. The new premises are in the Gothic style, of red bricks, with elaborate stone dressings. The total cost, including the purchase of the site, was £2,300.

The monthly memorandum of the Labour Department of the Board of Trade states that the number of unemployed in the trade-unions making returns was at the end of March 3.1 per cent., compared with 4.4 per cent. in February and 2.5 per cent. in March of last year. Employment in the building trades remains good, the percentage of unemployed union members being 1.6, compared with 1.7 last month, and 1.2 per cent. in March, 1897. The furnishing trades have still further improved and are busy. The percentage of unemployed union members at the end of March was 1.3, compared with 2.8 last month and 0.7 in March, 1897.

The Plymouth Corporation on Monday received a communication from the Admiralty with reference to the proposal to develop Cattewater Harbour at a cost of nearly £700,000. The Admiralty consider the scheme would prove prejudicial to the naval interests of the port, and state that the removal of one or two shoals in Plymouth Sound, and certain conditions, with reference to the regulation of traffic in the Sound, would be indispensable to the Board's acquiescence. As these alterations in the scheme would involve an expenditure of an additional two hundred thousand pounds, the Bill now before Parliament will probably be withdrawn.

## MEETINGS FOR THE ENSUING WEEK.

SATURDAY (TO-MORROW).—St. Paul's Ecclesiological Society. Visit to St. Margaret's Church, Lichbury. 3 p.m.  
Edinburgh Architectural Association. Visit to St. Mary's Cathedral and Wester Coates House. 2.30 p.m.

MONDAY.—Society of Arts. "Sources of Commercial India-rubber," Cantor Lecture No. 2, by Dr. D. Morris, C.M.G. 8 p.m.

TUESDAY.—Institution of Civil Engineers. Annual Meeting of Members. 8 p.m.

WEDNESDAY.—Society of Arts. "Photography and Colour Printing," by Capt. W. de W. Abney, C.B. 8 p.m.

THURSDAY.—Society of Arts. "India and her Currency," by Sir Edward Sassoon, Bart. 4.30 p.m.  
Society of Architects. "The Decorative Use of Mosaic in Architecture," by Messrs. Diespeker and Co. St. James's Hall, Piccadilly. 8 p.m.

FRIDAY.—Architectural Association. Members' Soirée and Smoking Concert. Café Monico, Piccadilly-circus, W. 8 p.m.

## The Society of Architects.

Founded 1884. Incorporated 1893.

THE SIXTH ORDINARY MEETING of the Society of Architects for the Session 1897-98 will be held at the Rooms of the Society, at St. James's Hall, Piccadilly, W., on THURSDAY, April 28th, 1898, at Eight o'clock p.m., when a Paper has been kindly promised by Messrs. DIENSPERKER and CO., entitled "THE DECORATIVE USE OF MOSAIC IN ARCHITECTURE."

ELLIS MARSLAND, Hon. Sec.  
MONTAGU BALDWIN, M.A., Sec.

## CHIPS.

The town council of Hyde have raised the salary of their borough surveyor from £250 to £300 a year.

The Diamond Jubilee Nursing Institute in Walsall-road, Wednesbury, was formally opened on Tuesday. It has been built from plans by Mr. Joynton at a cost of £1,450.

At Worcester, on Tuesday, a new nurses' home to be used in connection with the general infirmary, was opened by Lady Mary Lygon. Mr. Lears Sheppard was the architect, and Messrs. J. S. Wood and Son were the builders. The cost has been £4,500.

On Wednesday in last week, the church of St. Mary, Gosforth, Cumberland, was reopened after restoration, having been almost entirely rebuilt at a cost of £3,000. A Scandinavian cross, dating from the 7th or 8th century, stands in the churchyard. It is about 17ft. high. Two curious hog-back or coped gravestones have been discovered and preserved, which were excavated from the foundations, as were also several 14th-century grave crosses. Two 12th or 13th-century north and south doorways also came to light.

At St. James's, Walthamstow, on Thursday in last week, new Sunday-schools and a parish-room, built at a cost of £2,400, were dedicated by Archdeacon Stevens.

The Early Perpendicular parish church of Broadhempston, near Totnes, was reopened on Wednesday week after restoration. The work has been under the direction of Mr. Edmund Sedding.

The foundation-stones of an Independent Methodist mission church, Kendal-street, Wigau, were laid on Saturday. The church in course of erection is in the neighbourhood of Frog, Woodhouse, and Gidlow-ianes, and is being built by Messrs. Joseph Wilson and Son at a cost of over £585.

At the meeting of the Derbyshire County Council held at Derby on Friday, the report was considered of the asylum committee, who asked for a sum of £42,840 for the purposes of extensions and improvements at Mickleover Asylum. It is proposed to make a provision for 750 patients altogether, and then to stop the extensions at Mickleover, and if necessary to build a new asylum in another portion of the county. Mr. Alderman Waite criticised the estimate adversely, alleging that it was very excessive. The cost worked out to £161 per bed, as against £107 in the case of the Derby Borough Asylum. He moved an amendment to the effect that the matter be referred back to the committee. After a long and animated discussion, the amendment was carried by 23 votes to 15.

Mr. Alfred Young Nutt, surveyor to the Dean and Chapter of St. George's Chapel, has been appointed clerk of works at Windsor Castle. Mr. Nutt 15 years ago designed and carried out the restoration of the exterior of St. George's Chapel, and he has recently been engaged on several works of art for the Queen and Princess Henry of Battenberg, including the memorial to the late Prince Henry of Battenberg, erected in Whippingham Church.

# THE BUILDING NEWS

## AND ENGINEERING JOURNAL.

VOL. LXXIV.—No. 2260.

FRIDAY, APRIL 29, 1898.

### ARCHITECTURE AT THE ROYAL ACADEMY.—I.

THERE seems, on the whole, to be less mediocre work in the gallery devoted to Architecture than of late years at Burlington House, though the visitor will experience no difficulty in discovering a few atrocities which are devoid of even a mere degree of cleverness, while it is no injustice to say that some of the exhibits are absolutely poor both in drawing and design, or else they are entirely uninteresting and commonplace.

Before concluding our notes we will justify these remarks by quoting instances, because the architect Academician who made the final choice ought to have excluded such things, seeing that several really good drawings of clever buildings were turned away on the stereotyped plea of "want of space." Though there may be nothing which will permanently rank as a really great work of art of the first order in the architectural room this year, it must, nevertheless, be acknowledged that the collection, as a whole, includes many spirited and ambitious designs which serve to make the show interesting. Possibly the best things are among the minor exhibits, for in these things there is less chance of going wrong.

The gallery contains no drawings by either Mr. Norman Shaw, R.A., or Mr. Alfred Waterhouse, R.A.; but Mr. T. G. Jackson, R.A., exhibits his diploma work, the New Schools, Oxford University, besides the New Domed Chapel of Giggleswick School (1647), and some more school buildings at Uppingham (1648). Of the three compositions the chapel is by far the most original and capable, marked, as the design is, by a freedom from precedent at once masterly and unmannered. These qualities seem to be wanting in the University Schools, though by reason of size and distribution of plan their grouping is, of course, important and dignified. The design, too, is also richly detailed in a suitable style. For all that, the propriety of "the High" is too evident, and the respectably correct element, which dominates the conception, robs the building of those higher qualities naturally expected in the diploma work of an ambitious Academician. The only other R.A. who exhibits is Mr. George Aitchison, and his single frame shows in section some refined decorations in marble mosaic and paint, tastefully proposed for a private chapel surmounted by a dome (1604). Mr. G. F. Bodley, A.R.A., sends a very nice drawing by Mr. Raffles Davison, of the east end of Chapel Allerton Church, near Leeds—an exceedingly long building, with a detached tower of square proportions, very simple and reserved in design. The chancel window is flanked by niches containing statues, and its Decorated English tracery is set off by a breadth of wall space in the gable end, which is rather refreshing. Mr. Bodley has designed a pulpit, too, for St. Michael's Church, Croydon (1714), giving it a spire-like canopy of florid wainscot elaboration, confined within simple lines, and surmounted by a statue of the Archangel. This work is shown by a bright pen-and-ink elevation. It is fairly evident that Mr. John Belcher has some very influential friends at the Royal Academy, for he has no less than six exhibits, which, taken together, must cover a large amount of coveted wall space. Foremost among these hangs his design for the new Guildhall façade at Cambridge, with its ill-proportioned columns and queer detail,

perhaps the worst thing of its size and character shown of late by so capable an architect. We can hardly imagine a more incongruous design, and think the ball terminals over the pediments of the end towers are most ungainly. Mr. Belcher's work has sometimes been so clever, and it is always marked, we readily admit, by an endeavour to do something fresh, so that onlookers can but wonder, after seeing this elevation and his Colchester Town Hall (1756), what vagary is next to be displayed. The Colchester design seems to have been considerably modified since the competition, and is here shown by a fresh drawing, a capital water-colour of much ability by a well-known hand. The big tower which distinguishes the grouping sits badly at the angle of the building, rising in an awkward and ill-considered way out of the roof close to the hip. The fenestration looks over-large in scale in the façade, and the main windows are flanked by the same lankily-shaped columns as before mentioned, while at the corner both elevations lack solidarity and breadth under the weight of such a tower. The details of its crowning stage exhibit taste and ability. The seated figure in front is probably sufficient for a show drawing such as this (1743); but it has been seen somewhere, surely, before. However, good sculpture is to be always welcomed—and we know that this is Mr. Belcher's intention in this case. We have nothing but praise for his interior of the Entrance Hall to a House at Pangbourne. It has a square, simple vault, enriched with plaster strap-work and panels. The whole effect is pretty and effectively quaint without effort. As to the exterior of the same mansion (1753), we do not like it a little bit. The design is scarcely more than a hotch-potch of ugly parts, and it shows how unequal Mr. Belcher can be. What is there in common, it may well be asked, between the garden-front pavilions and the flatly hipped roofs of the main building which they flank? Again, no one can fail to remark how ill-fashioned the central pediment is, rising over two canted bays. Call it Later Renaissance, or what you will, this, after all, is not good architecture; and then, too, how can anyone admire the poorly grouped squat tower in the hind-parts of the composition? We have devoted this much space to Mr. Belcher's exhibits because the authorities evidently think very highly of them to the exclusion of other designs, and because, whatever their demerits, these productions of Mr. Belcher's at any rate may rank as departures from the ordinary and commonplace, a remark which means a good deal. At least, they challenge criticism. Malvern College Chapel is the single work shown by Sir Arthur Blomfield, A.R.A., and this interior of his may be taken as a typical example of a thoroughly scholarly architect's multifarious designs, always admirable from the client's standpoint and good in a popular sense as tasteful and satisfactory buildings. Mr. Aston Webb's work this year is represented by three samplers, and when, as in this case, all are successes, it is not necessary perhaps to express a preference. The Yacht Club, village shops, and other premises at Yarmouth, Isle of Wight (1762) make an uncommonly picturesque group, beautifully delineated by Mr. Davison. This architect's sense of fitness is admirably exemplified in these waterside buildings; an observation which, with equal truth, is applicable to his Greenwich Grain Silo (1774), a design of exceptional merit, which, however, failed to find a place in this same gallery last year. Hildon House, Hampshire, another characteristic work by Mr. Aston Webb, is represented by two perspectives crisply drawn with close attention to detail, even though they fail somehow to set these capable compositions off to the best advantage. Perhaps the work itself is lacking in the

contrast of repose only to be secured by the use of broad wall spaces. "Okewood," Sussex (1609), by Messrs. Ernest George and Yeates, is a small house, and altogether less ambitious; but it illustrates the breadth of design just suggested. To compare the two buildings of such different aim would, however, be meaningless. The same architects exhibit the fireplace and bookcases of the library at North Mymms, Herts (1608), a richly-treated mansion by Mr. Ernest George, which we illustrated a few years ago. The two largest undertakings in the Architectural room this year hang one over the other, and by reason of their importance as comprehensive building schemes must attract much attention. The first of these is the selected design for the Royal Masonic Institution for Boys at Bushey (1632), by Messrs. Gordon, Lowther, and Gunton. We illustrated this same drawing in the BUILDING NEWS on March 11. The other is Messrs. Lanchester, Stewart, and Rickards' selected design for the Cardiff Town Hall and Law Courts. Mr. Rickards' drawing here exhibited is a skilful performance, and shows the entire group in a comprehensive way; but in spite of the originality and ability of the design, we still feel unable to acknowledge the wisdom of Mr. Waterhouse's choice. Our space today leaves us no more room for further references, though we welcome Mr. Mountford's model of part of his Liverpool Technical School and Museum Building (1804). It helps the better understanding of the view (1782), which, if we remember rightly, he sent to Burlington House unsuccessfully last year. The same architect exhibits St. Michael's Church, Southfields, S.W. (1802), which looks a very nicely designed piece of work. One of the most satisfactory of all the buildings represented is Roedean School (1685), by Mr. J. W. Simpson, a very large establishment now in course of erection between Brighton and Rottingdean. It is uncommonly well designed, simple, picturesque, and dignified.

### PICTURES AT THE ROYAL ACADEMY.

[FIRST NOTICE.]

WITH a few brilliant exceptions, the pictures in the exhibition of Burlington House, to be opened to the public next Monday, are of the kind which appeal to popular sympathies and to the general picture admirer. As on previous occasions, we shall merely glance here at a few of the principal works in the first three or four rooms, as we take up in order the several galleries. Landscape, seascapes, portraiture, and works of *genre* take up by far the greater portion of the walls, while of historical or ideal subjects there are not many of any great merit. Examples of "cults" do not find favour at the Academy, though here and there one may see methods almost as audacious as those of men of the school to which Arthur Melville belongs. But colour harmonists, visionists, or experimentalists are not popular.

As in most Academies, we see many pictures that portray neither nature nor history nor commonplace incident, but can only be classed as enigmatic or symbolic, in which the painter with a consummate sense of the subtle or the harmonious or the mere technical idealises. These painters are not without their place in art: they seek to give us visions of beauty that appeal only to a higher plane, but are not understood by the many. We see two subjects of this kind in the New Gallery, by M. Knopff. Sometimes it is a portrait decoratively treated like Mr. Gotch gave us last year in his "Heir to all the Ages"; sometimes it is a superb scheme of colour; sometimes it is a mysterious composition suggestive rather than descriptive. These men are non-realists, and depend more

on subtle forms or hues or exquisite finish than upon any natural kind of art. In the first gallery the first great picture that arrests attention is Briton Riviere's "The Temptation in the Wilderness" (22), where the solitary white-robed figure of our Saviour, His head bent low, kneels on the summit of a rocky plain, His vesture is illumined by the departing light of a sunset which is seen on the distant horizon. The scene depicted is like a dark, desolate sea of billow-like rocks, on which kneels the solitary figure of Christ. There is power and pathos in the picture. "The Magic Crystal," by Fred Stead (4), a girl in green dress, holding in both hands the magic ball which she is closely examining, and which she has just taken from a casket, is painted with much poetry. The colour is admirable. One picture by H. W. B. Davis, "A June Evening," is in this gallery. It represents a beautiful landscape, brightened by gleams of the warm sunset and with blossoming trees. Cows are wending their way homeward. In the third gallery this painter has another charming subject, "On the Upper Wye" (221), and a very beautiful landscape in the fifth gallery, "Under the Greenwood Tree" (387), which we shall notice later on. H. H. La Thangue, in his "Nightfall" (29)— gleaners in a cornfield, a moonlight study—is worthy of his last year's work, and we must just notice, in passing quickly through this gallery, a view of "Newcastle-on-Tyne," by Niels M. Lund, a grand study of smoke-laden atmosphere over this city of the north. Mr. Lund has invested the murky city of Newcastle with a poetic charm of its own. Vapour and smoke in his hands are made to assume a beautiful canopy of light and gloom, here throwing into strong relief the buildings and steeples, and there lighting up with visionary splendour the squalid streets of a busy centre of human life and industry. Another important picture is J. W. Waterhouse's "Flora and the Zephyrs" (64), a delightful and flower-strewn mead near a river, dotted with violets, in which a pathetic-looking maiden is being ministered to by aerial damsels, who are entwining her with a garland of white roses, while her fair attendants are grouped round her. The wistful countenances of the fair maidens and the subdued colours are thoroughly characteristic of this painter's work. The same faces appeared in the painter's St. Cecilia and his last year's picture of "Hylas and the Nymphs." A capital portrait of Mr. Francis Cranmer Penrose, P.R.I.B.A., by John S. Sargent, and a graceful portrait of Grace, wife of Mr. H. Passmore Edwards, by E. Constable Alston, must be noticed here. Also a fresh work by J. C. Hook, "Idlers" (70), and a pleasing piece of *genre* by F. D. Millet, which we must notice in detail. In Gallery II., the principal position is occupied by a noble Shakesperian subject by Edwin A. Abbey, quite equal to his last year's "Hamlet." We must reserve our description and critical examination for next week. The scene depicted is "King Lear, Act I., Scene 1" (138), where Cordelia is leaving her sisters:—

Ye jewels of our father, with wash'd eyes  
Cordelia leaves you. I know you, what you are;  
And, like a sister, am most loth to call  
Your faults as they are named. Love well our father.  
To you professed bossoms I commit him, &c.

The composition, costumes, rich but subdued colour, black and scarlet, the graceful figures of Lear's daughter, clad in the daintiest robes, make this another triumph of this great American painter. But greater than all these pictorial and technical qualities is the pathos and dramatic power which Mr. Abbey has imparted to his work.

Fredk. Goodall's Oriental scene—a harem interior—entitled "A Gilded Cage," is rather hackneyed, though clever as a work of technique. Stanhope A. Forbes sends a very admirable and pathetically-painted subject more unambitious than usual. "October" is the title, and must be taken, of course, in

a figurative sense. An aged woman and young girl have come down the steps of the raised churchyard. Other pictures of interest here are W. Logsdail's Venetian subject, "Going to the Procession"—a little girl attired in white, with a wreath of flowers and basket of rich blossom on her arm, crossing the canal bridge with her mother.

In the third gallery, the president, Sir E. J. Poynter, has an important classical subject called "The Skirt Dance" (222), which occupies the position so often given to Leighton's chief works. We are inclined to say at a first glance that this work is one of the most successful we have seen. In a sumptuous alcove adjoining the vestibule of a Roman palace, a young girl clad in diaphanous tissue of light salmon tint is dancing before a patrician lady, richly attired and jewelled, and her female friends and attendants, who are seated on a white marble bench which encircles the interior. The richest marble columns with gilded bases surround the alcove, and the floor on which the maiden is dancing is of tessellated marble. Beyond one sees glimpses of a garden and a spacious columned hall. There is poetry of motion and grace of line and drapery in the dancing girl, which atones for much of a certain technical exuberance and hardness. The lady and her companions looking on, a girl with dice on a seat, and two maidens reclining in conversation make up a picture of interest. A chaplet of roses has been thrown at the dancer's feet. George H. Boughton has a large picture from the "Lady of Shalott," "The Road to Camelot." It is painted in a light colour, depicting Tennyson's poem:—

And moving thro' a mirror clear  
That hangs before her all the year,  
Shadows of the world appear;  
There she sees the highway near,  
Winding down to Camelot.

The painter represents the passing scene, the river, the "surlly village churls," the "market girls," a troop of damsels, a crimson-clad page with his dog, and in the distance beyond the river knights on horses "riding two and two." J. W. Waterhouse's "Ariadne" (211) represents the daughter of Minos, who fell in love with Theseus, reposing on a couch in a garden by the sea. She is partially draped in scarlet, open at her bosom, her hands behind her head. Leopards crouch underneath and near her. The composition and colour are admirable. On the opposite wall Alma-Tadema has his only picture, "The Conversion of Paula." Unsurpassed in its technical qualities, this picture is perhaps less attractive than many others which have preceded it. Paula reclines on a marble seat, one arm resting on the parapet, while she is listening attentively to the youth behind her who is pleading his faith. It is a brilliant and beautifully-executed subject. Paula is a daughter of one of the Gracchi. Her long oval face is not exactly beautiful, but is painted with extreme care, while her companion is tanned, and has a purple or dark blue robe.

We have, as usual, the elements of the painter's classical compositions—marble, transparent tissues, and subtle colour. A white marble terrace or balcony faces the deep-blue sea, illumined by strong sunlight; a marble staircase leads to a temple. Paula, with auburn tresses and jewelled diadem, reclines beside an altar devoted to Bacchus, decorated with a silver vase; she is attired in rich russet and amber tissues shot with gold, and displays all the beauty of a Roman lady of this luxurious period. She is depicted attentively listening to the handsome and austere young saint, robed in dark blue and white, who holds a scroll, and is persuasively pleading with the fair maiden, who seems to realise the truth of his argument. The embroidered dress of the young saint and the sensuous beauty and sumptuous attire of the beautiful convert are, it is needless to say, limned with marvellous skill.

Of other pictures, we must mention briefly B. W. Leader's landscapes. "In a Welsh Valley" (188) is a beautiful scene, with a mountain background, which catches a soft light; and in the next gallery we have two more of those placid and brilliant renderings: "Where Peaceful Waters Glide" (309) and "The Silver Sea" (314). In the former, a clear and transparent atmosphere, the hill tipped by sunlight, and placid water; the latter is a tract of sandy beach, with grassy hillocks, and a silvery sea gently breaking on the shore. Hubert Herkomer's great centre picture, "The Guards' Cheer"—an episode of the Diamond Jubilee Procession—(198), is an ambitious picture. The scarlet uniforms of the guards, and their lusty cheers are realistically depicted. John Brett has one of his finest efforts, "Trevose Head, Cornwall" (194), a coast scene. There is freshness and beautiful colour in the sea and breaking waves. J. MacWhirter also, in "Morning, Isle of Arran," paints an unclouded coast of exquisite colour: a vast bay reflecting the ocean sunlight between rising hills of verdure.

W. Q. Orchardson sends four pictures. No. 243, "Trouble," is a touching incident, rendered with that harmony of amber tones and sumptuous surroundings that distinguish his renderings in high life. We are left to conjecture the meaning of "Trouble." Prostrate with grief is a young man in black, his head buried in his arms resting on a rich ormolu table; the young wife behind him, attired in elegant evening robe with long skirt of delicate shade of salmon and low bodice, has one hand on the back of his chair, and is turning her face towards him in pity. A little bunch of flowers, a fan, and gloves lie on the table beside the young husband, and on a chair near is a white fur cloak. In the distant part of the room is a pink-shaded lamp. The spectator is left to imagine what the trouble is, but it may be in the written letter or document which lies beside him. The painter, in his customary simple, but elegant and refined manner, tells the tale only too clearly and dramatically. The interior is one of those elegant Louis XVI. drawing-rooms we have seen so often before, richly carpeted and furnished. His other works are portraits—that of Miss Fairfax Rhodes, in very delicate dress and colour, is extremely graceful as an example of portraiture. A skilfully painted and pathetic picture is "Sunshine and Shadow," by Gwilt Jolley (266), a funeral procession in some Italian city, headed by the cross-bearer and followed by the priest and mourners, preceding a handsome casket overlaid with flowers. Behind the rising city is bathed in sunshine, while the foreground and procession are veiled in a haze. The rich vestments of the priest, and acolytes are well painted. One of the most sumptuous figure subjects is Frank Dicksee's "An Offering." Rose-colour, white silk brocades, and golden tissues are, it is needless to say, predominant in this composition. The subject represents a dark haired gallant offering a silver cupid to a beautiful girl in white brocaded satin, who is seated on a handsome chair beside him. The lady is most richly attired, and wears a pearl necklace and rich jewelled brooch. Round her the rose lining of her cloak sets off the faultless and glistening whiteness of the low satin dress, and behind her hang gorgeous hangings. Mr. Dicksee has exceeded himself in this picture of fair beauty and richness of colour. Very graceful is Arthur Hacker's portrait of "Mrs. Samuel Butler" (279), and we must also notice the two seascapes of J. C. Hook, whose fresh coast scenes generally adorn this side of the large gallery. "Trouble with the Old Muzzle-Loader," and No. 278, illustrative of some lines by Matthew Arnold, are both fresh and full of sunshine and colour. George W. Joy's large canvas over the President's picture "Christ and

the Little Child," illustrating St. Luke ix. 47 and 48, is not a success. We must notice in passing Peter Graham's fine "Moorland Quietude," and Edwin A. Abbey's picture of "The Bridge" (234), a quaintly-conceived work. The painter's knowledge of costume and historical incident is aptly brought out. The scene represents a Mediæval bridge opposite a sombre fortress-like building or monastery seen against a sunset sky. Monks singly and in groups are crossing the bridge to the monastery, while a parti-coloured jester is playing a mandolin, seated on the corner of the bridge; by his side, in the parapet, are two apples and his bundle. There is a pleasing quaintness and contrast in the picture, which places it above modern everyday incident.

### THE NEW GALLERY.

THE pictures at the New Gallery are very diverse in character and treatment, and there is a strong sprinkling of the "advanced" school of all ranks and degrees. Here we can only name a few of the more important features of the exhibition, and it will be difficult to say which are the chief pictures among so many works of admitted masters. The most ambitious in the South Room is the tall, upright canvas by G. E. A. Abbey, A.R.A. (39), "A Poet," a rather wide title. The poet in this subject is dressed in a loose white robe, and is reciting to a group of ladies his composition, one hand holding up a bright red flower. The scene is some Florentine grove or vista of lofty cypresses, through which a flight of steps ascends. A red setting sun is seen through the dark foliage. On the right stands a circular temple, faulty in its architectural details. Well dressed ladies are seated or standing listening to the poet, and in rapt attention; but the theme is rather tame—certainly not equal to the scale attempted; nor to other and finer themes painted by Mr. Abbey, such as that in the Academy this year. Moffat Lindner's "Breezy Holland" (1) is a delightful piece of sea-painting, with its dappled waters and majestic clouds, bright and breezy. While at the end of the room is Walter Crane's large allegorical composition "The World's Conquerors," a gorgeous procession of valorous knights and ladies, Fame, Power, Beauty, Time, and Death taking part in the array. The design is ambitious, and there is ability shown; but the subject is somewhat hackneyed if instructive. There are many pre-Raphaelite pictures, two by Holman Hunt himself, and two by Sir E. Burne Jones, in other rooms; but here we note Harrington Mann's flatly-painted picture (4) "A Song of Spring," an orchard full of spring blossom, and a group of maidens seated or standing playing musical instruments. There is a true sentiment in the faces of the sisters, one clad in black with a crucifix suspended from her waist. Julian Story's "Song" (14), Madame Eames, as the Countess in the "Nozze di Figaro," is an exceedingly clever group, the lady singing to an accompanist at the piano, dressed as a courtier—admirable in composition and delicacy of colour. Alfred Parsons' "Sweet Williams" (31) and "The Back of the Village," an orchard of spring blossom and sunshine (35), Miss Flora Reid's picture of "Charity" (44), and Miss Annora Bromley-Martin's "Evening" (70), a procession of girls and women-gleaners trudging their way home by the side of a river, quite pre-Raphaelite—are pictures of undoubted merit. Alfred Hartley's "On the South Downs" (5), the crown of a hill "kissed" by a bright cumulous cloud, is a charming landscape. In the West Room Sir Edward Burne-Jones's large upright picture "St. George" comes opportunely on the feast of the patron saint; but it is scarcely more than a clever conventional treatment of St. George in armour

with his mystic shield, and a landscape behind. Sir Edward's other subject "The Prioress's Tale" (82), is more characteristic of the painter's style and methods. There is a mediæval quaintness in the details of the priory precincts, the little child and the prioress are in keeping with Chaucer's quaint verse in the "Canterbury Pilgrimage," and quite pre-Raphaelite in feeling. "Early Spring," by G. F. Watts, R.A. (113), a little fair boy holding flowers which he has been picking, is hung at the end of gallery, and is a charming and expressive work, putting us in mind of Millais; while at the other end of room is a more mysterious but wonderful picture, "Can these bones live?" The visitor may ask the meaning of the gloomy landscape, the uprooted tree and broken branches that shelter the skeleton, or the drapery-like covering which partially covers the bones, near which are seen the tools and baubles of life—the cups, dice, and other relics of poor humanity. The composition in its mysterious solemnity is one of much power. Mrs. Alma Tadema's "An Impromptu" is a *bon bouche* piece of genre. J. M. Strudwick's Mediæval harmony, as we may call it, "Evensong," is full of detail and rich colour; Fernand Khnopff's "L'Encens" (76) is a delightfully delicate and symbolic study of a lady wearing an embroidered cope or cloak in silvery tones of grey, expressive of the flattered, and we may also notice his "Une Aile Bleu" as another enigmatic subject and clever piece of colour harmony. G. H. Boughton, R.A., has a cleverly painted and pathetic figure-subject, "When the Dead Leaves Fall" (116), a dark and beautiful woman walking through a shower of falling leaves in a wood; and near it Geo. Wetherbee's "A Spring Phantasy" may be noticed for its decorative beauty and delicate colour. A. D. Peppercorn's large, sombre landscape, "The Common" (136), and William Logsdail's brilliant Venetian subject, "The Market Boats," a delightful piece of drawing and colour (130), and the fine colour in Leslie Thomson's "Arcadia" may be mentioned. In the large gallery several remarkable portraits are to be seen. Byam Shaw's portrait, "Evelyn" (192), is a decorative experiment that may not meet general approval. The young lady, full length, stands in perfectly symmetrical pose against a golden background, in which the arms of the family are cleverly interwoven. It is painted with great care and grace; the dress is black, with a green fur-trimmed cape. Near Mr. Carolus Duran's portrait of "Joy," daughter of Lord and Lady Algernon Lennox, is a charming study of a flaxen-haired and delicately-featured little girl, executed with much finish. Then we have John S. Sargent's portrait of "Mrs. Thursby" (200). The lady seems to be leaning forward or rising from the chair, and the whole is forcibly painted, but is wanting in the reposeful qualities of portraiture. As for Arthur Melville's colossal canvas of "Mrs. Graham Robertson" (207), the less said the better. The scale and brushwork are alike extraordinary; but, then, it is the style of a new cult. J. J. Shannon's "Miss Berthe des Clayes" is a refined and delicate rendering of portraiture of a nice-looking girl leaning against a Japanese cabinet. Mrs. Swynnerton's "St. Martin's Summer" is symbolic—a ruddy face, blonde, enveloped in what looks like mists and vapour of autumnal hues. Alfred East's "A Mystic Pool," and (218) Thorne-waite's large landscape, "The Deal and Dover Road" (237), with the gleaming line of chalk cliffs and sea and the wet lane along a fringe of trees skirting the coast, are very different—one dark and mystical, the other full of light, but both noticeable works. We have also the two delicate studies in white in Miss Mary L. Gow's favourite manner, "A Dance" (232), and "A Fortune." T. Austen Brown's "Grey Mare" is masterly and

sympathetic, and we have another fine landscape in James MacWhirter's "Valley of Flowers, Murren" (247). The colossal canvas, "Too Late," by George Harcourt, from Christina G. Rossetti's verse (253), is more ambitious than successful. Holman Hunt's picture, "The Beloved," is a wonderful creation of the master of the great school of pre-Raphaelitism, though the over-floral colour almost spoils a face full of human emotion and tenderness. Mr. Ernest Parton, Alfred East, J. T. Nettleship, and other well-known painters send subjects. The Hon. John Collier's "Godiva" is a brilliantly-painted but rather hackneyed subject;—the rich and embroidered trappings of the charger are even more attractive than the fair rider herself, a young and modest girl.

### MODEL SPECIFICATIONS.—X.

#### TERRACOTTA WORK.

THE employment of terracotta for architectural purposes is a large theme, and we desire here rather to point to what should be avoided rather than to the possible uses of this valuable material. And one of the first cautions is to avoid large projections—in other words, to keep the treatment rather flat. A heavy projection entails large blocks, with increasing difficulty of keeping them true; it also suggests the imitation of stonework, both of which are objectionable. The over-lavish use of terracotta is one of the greatest mistakes our architects are making. This lavishness in its employment is disgusting the artist and the public alike, and will do more to cause a reaction in favour of stone or brickwork than anything else. No doubt this excess in its use is due largely to the comparative cheapness of the material. The architect who looks more to commission than to the art qualities of his buildings plays into the hands of manufacturers by using or specifying elaborate examples of ornament. He sees an illustrated catalogue full of patterns of enriched pilasters, friezes, pediments, string-courses, and the like, and at once, without considering the purpose or character of his building, he specifies them. It saves him trouble in designing in detail, and it does a turn to the maker. Let the architect pause before he selects an elaborate frieze, or string-course, or door-head, for instead of accentuating his design, it virtually destroys its repose and breadth. Let him keep this restraining caution in mind by asking: "Were I using stone instead, should I have this elaborate panel enrichment, or arabesque in the pilasters, or this very elaborate frieze ornament? Why should I have this string-course, or entablature full of acanthus-leaf, or egg-and-tongue or other enrichments, when I would not have them in stone? It is true terracotta is more durable, harder, and cheaper than soft stone; but am I not throwing away so much ornament in this or that position?" The great mischief of extravagant ornament is that it becomes commonplace and cheap, and, as in over-dress, destroys the very intention it was desired to promote—namely, richness of effect by contrast with plain surfaces. All repose and breadth is lost if we cut up a front or a gable with enriched pilasters and panels and friezes, and the lines of accentuation are sacrificed. There is a mania among builders and architectural "pot-boilers" to fill in panels and wall-spaces everywhere—a practice which defeats its purpose by producing confusion rather than effectiveness. Public-house and restaurant builders are adepts at this kind of artistic extravagance. Ornament should not be cast like stone is carved; undercutting should be avoided, and low relief is more adapted to the material.

In the design of terracotta work, the architect should remember that the material is limited to casting and moulding chiefly.

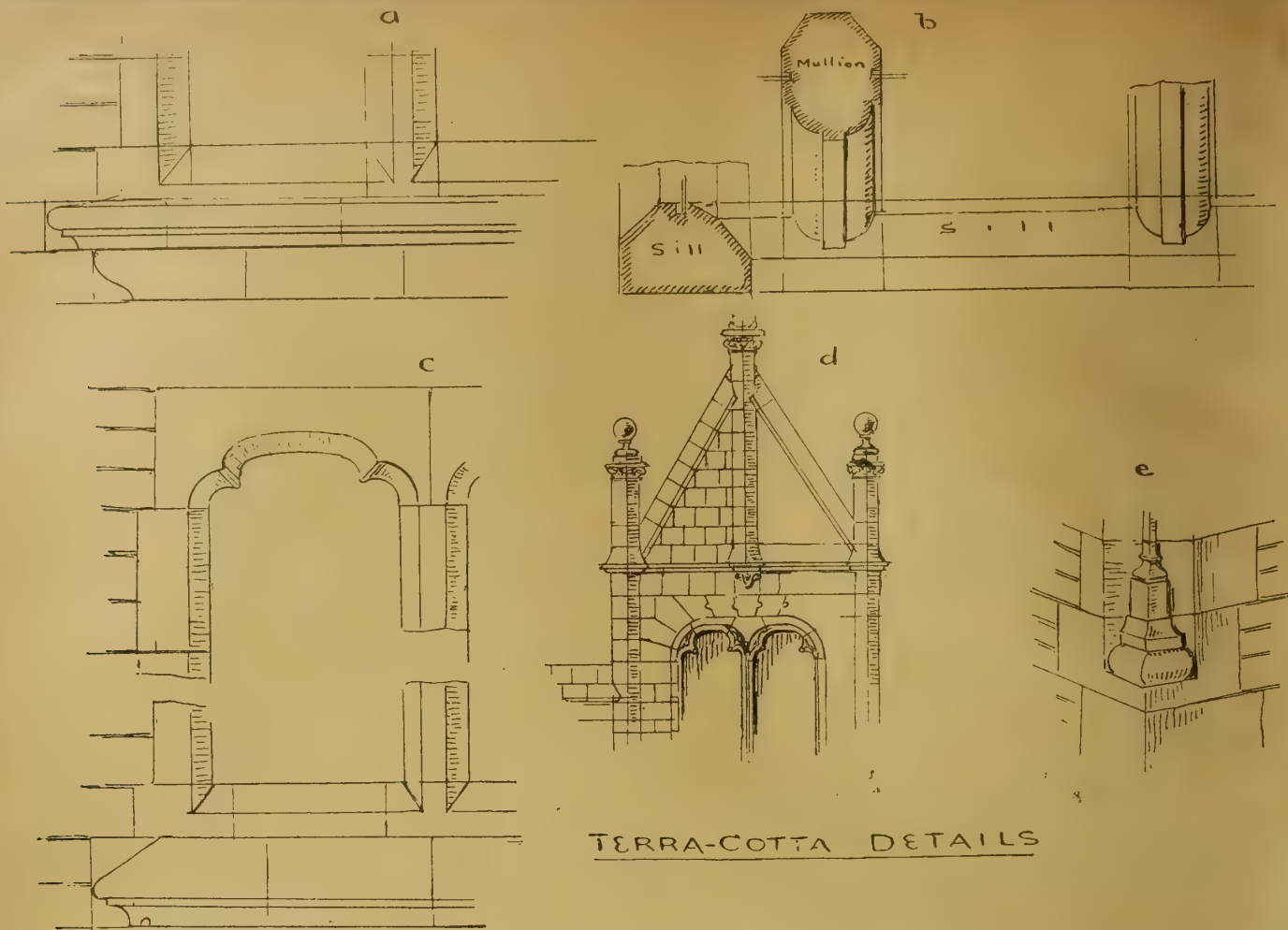

TERRACOTTA DETAILS

The clay can be moulded, however, direct by the artist. As to the difficulties of shrinkage in the kiln, the architect should find the necessary allowance to be made for the clay, and make his drawings to an enlarged scale. The material is liable to warp and twist, both in the lines and surfaces, and therefore the fine delicate members of Greek mouldings cannot be attempted. Bolder mouldings are necessary. Nor must the designer follow the treatment of stonework: the methods of treating stone are not suitable to terracotta. Thus deep undercut mouldings or ornament would be absurd to attempt in a moulded or cast material. Again, large blocks of stone cannot be imitated in terracotta, the jointing of which ought to be closer and more regular (see sketches of gables we give here). In a column shaft, for instance, the smaller and more regular the pieces are the better. Messrs. Doulton have introduced a new process of making terracotta in cellular blocks, which gives advantages. According to the ordinary manufacturer, all the skilled labour is expended in models and moulds, while the executed blocks are often inferior reproductions. Messrs. Doulton's method avoids this: each block of the clay is subjected to considerable pressure, and is like stone in density; it can be worked upon directly like stone while in a plastic state, with templates and squares, so that great accuracy is attainable, and shrinkage is an eliminated factor. Columns, architraves, string-courses, cornices, &c., can be turned out with the sharpest arrises. As no casting processes are employed, the drawings need not be prepared to a larger scale. According to this method also the cellular blocks are perforated horizontally, so that no filling with concrete is necessary, and the blocks are able to sustain considerable weights. We may here refer to the wedge-shaped joggle in flat arches and lintels as generally used. It is an old kind of joint, and is seen in masonry structures as well as terracotta, as in the

Diocletian Palace, Spalatro, and in many foreign buildings. The French *crossettes*, as this contrivance is called, was no doubt introduced for the purpose of preventing the voussoirs of flat arches from slipping down. The joggle prevents this. In terracotta work, this plan, though perhaps not altogether to be approved in every case, is largely used, and we see very long lintels and flat arches and transoms jointed in this way. In a thin transom the joggle is perhaps almost necessary, unless a flat bar of wrought iron is introduced under the pieces, which is objectionable. Architraves and entablatures over intercolumniations are generally jointed in this manner, and when the pieces are truly moulded and the joggled joints accurately fit after burning, neat work can be produced.

In addition to clauses 1, 2, 3 in our last article, the following are special clauses that may be used before specifying any particular work in terracotta.

11. *General*.—The terracotta shall be buff (or red), well burnt and of even colour, subject to the architect's approval. No chambered block is to be less than 2in. thick. The surfaces are not to be coloured or washed, nor filed or rubbed. All hollows are to be filled in solid with fine lime concrete, the block being first soaked in water. No piece is to exceed 2ft. cube. The blocks to be well bonded with the brickwork, set in fine mortar, neatly pointed as the work proceeds, and cleaned down at completion. All the mouldings and arrises to be true in line, and sharp.

The contractor (or clerk of works) is to assist the manufacturer in setting out any particular work, and to supply the modeller with a workshop. All damaged pieces to be replaced by contractor at his own expense. The manufacturer (or contractor) is to be responsible for any shrinkage, and for the size and accuracy of each block, and is to make the necessary allowance for same.

12. *Filling*.—The hollows of the blocks to be soaked in water, and afterwards filled with fine concrete in the proportion of 1 part by measure of Portland cement, 2 of sand, and 4 of clean, fine ballast to pass through an inch ring.

13. *Joints and Joggles, &c.*—The terracotta block used in arches, lintels, pediments, columns, &c. to be jointed in accordance with detail drawings, and to be chambered as required. The rebates, mortises, joggles, and grooves to be prepared before the burning, so as to require no subsequent filing or rubbing. All the pieces to be thoroughly bonded and coursed with the brickwork, and the contractor (or fixer) is to include any cutting, fitting, pinning, or bonding that may be required.

14. *Ornamental Terracotta*.—The ornamental or enriched pieces to be artistically modelled to the design, and to meet with the architect's approval before being fixed; the pieces to be turned out clean and sharp and equal to the models, well burned, and of even colour.

15. *Window Sills*.—The window sills (see sketches a, b, and c) to be of well-burnt terracotta, cane-coloured (or red), 6in. deep, moulded, grooved, and throated according to section, and to project 4in. (or 6in.) beyond the face of wall, with mitred ends set in cement, and pointed with coloured cement. The arrises to be sharp, and the mouldings true in line. Or—

The sills to ground-floor windows to be moulded, weathered, and throated according to drawing, 6in. projection from face of wall, with mitred returns at end, bonded into brickwork set in cement, with joints not more than ¼in. thick, in coloured cement. The sills to have terracotta trusses underneath. All the blocks to be thoroughly burned, of uniform colour, and the arrises to be sharp and true when fixed.

16. *Window Heads*.—The window heads (shown in sketch) to be executed in terracotta, with joggled radiating pieces of the sizes shown in detail, and the jointing shown to be strictly adhered to (or, if without joggles, the radiating pieces to be dowelled together with cement); the frieze cornice over to be put together as shown, well pinned with cement into brickwork. The lines of mouldings to be true, and the arrises sharp. The whole to be set in fine mortar, the joints not exceeding ¼in. in thickness, and coloured to harmonise with the rest of the work (or neatly pointed as the work proceeds). The modelled ornament of frieze, the swags or figure groups on pediment, trusses, &c., to be approved by the architect before fixing.

Any piece of terracotta which may be damaged for want of protection during progress of works, is to be removed by the contractor, and replaced by a perfect piece at the contractor's expense.

TERRA-COTTA DETAILS

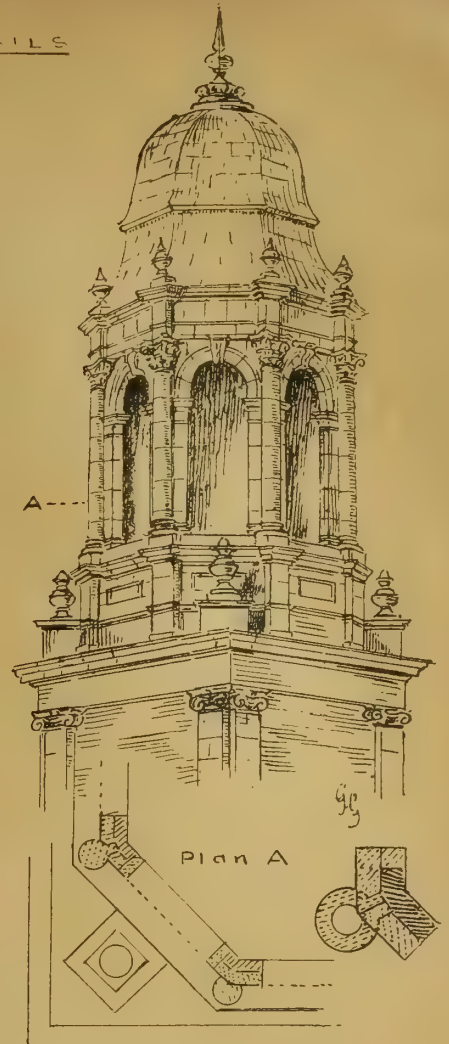
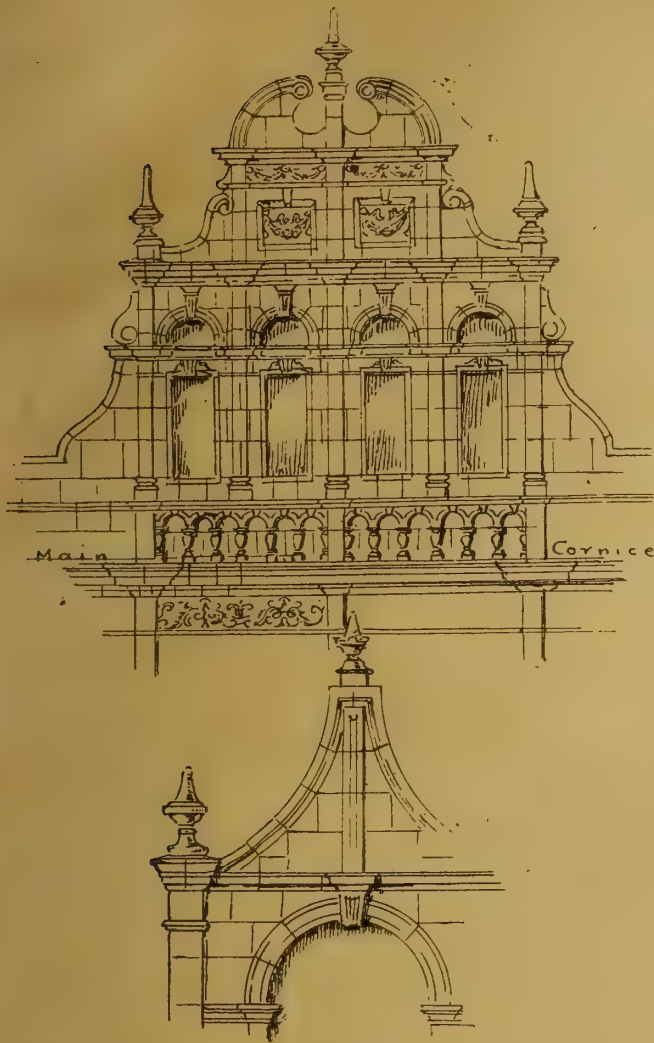

(Where the windows have mullions and transoms it is necessary to describe the manner or the size of pieces, see sketches a and b.)

17. *Mullions and Transoms.*—The mullions to be 4½ in. (or 6 in.) by 8 in. (or 10 in.) in section, and no piece is to exceed 9 in. (or 12 in.) in height, and the pieces to be set in fine mortar (or cement, or dowelled), and the vertical arrises and mouldings kept true and sharp.

The transoms to be jointed in accordance with detail drawings, or be put together in pieces with properly set-out radiating and joggled joints, set in cement mortar upon a frame or centre which is not to be struck till the work is finished.

The window (see sketch c) to have cusped window-heads made of terracotta and jointed over mullions as shown. (The head shown should not be longer than 18 in. to each light; if longer, the head should be jointed in three pieces with joggles, as in the two-light window-head shown in our sketch for a dormer gable, d.)

C. A. Bassett-Smith, Mr. G. H. Phillott, Mr. J. R. Manning, Mr. G. E. Bond, &c. The toast of "The Queen" having been given by the President, Alderman Sir David Evans proposed that of "The Houses of Parliament" coupled with the names of the Earl of Jersey and Mr. Ernest Flower, M.P., who responded, Lord Jersey alluding to the Government Buildings Act just passed as providing the way for an important Metropolitan improvement which would, it was hoped, afford a good architectural approach from Charing-cross to Westminster. The President gave the toast of "The Clergy," remarking that they had ever been among the best patrons of architects. The toast was acknowledged by the Rev. A. Mercer, who remarked that he officiated in a church designed by a member of that society, in which the acoustic properties and the means of ventilation were perfect; the Rev. Dean Vere also responded in a humorous anecdotal speech. The Hon. W. F. D. Smith, M.P., in proposing "The London County Council," referred to the fact that the President had from the first been a member of that body, and remarked that the Council had done much to improve and beautify London by clearing away insanitary areas and making new thoroughfares, and thus afforded new opportunities for the architectural profession. It had done an immense amount of useful and beneficial work. Lord Welby, in replying, said the County Council were constantly charged with being adventurous and extravagant; but it was, he claimed, essentially a modest and retiring body. They were compelled to carry on their business in an inadequate building in an obscure corner of St. James's Park. Once on a time they were inspired with ambition when they contemplated the palace in which the Houses of Parliament met, and even that wherein their colleagues on the London School Board worked; but when they put in a claim to be comfortably housed, their claim was contemptuously rejected by the House of Commons. He hoped that House would, in the not distant future, look upon their claims

with a more lenient eye, and permit them to provide themselves a larger residence which should contribute something to the honour and dignity of London. Mr. L. Atherley-Jones, Q.C., M.P., proposed the toast of the evening, that of "The Society of Architects and Architecture." The society had not, he observed, as yet attained very mature years; it had only reached the interesting age of pupillage, being, he believed, in its fifteenth year. But it had an object in view, which was to raise, not the individual status of its members, because that was scarcely a necessary object to aim at; but it sought to raise the standard of architecture, and to secure greater benefits for the public at large. He regretted very much the difficulties that had hitherto stood in the way of the passage of an Architects' Registration Bill, of which he had had charge for some years past. The present imbecility of private members was to be deplored, and it was in the greater pressure of business impossible to secure the passing of any measure which met with the smallest opposition. He would advise the profession, in face of the many difficulties before them, to resort to the system of lobbying to secure the passing of the Bill. There was a feeling against monopolies, both public and quasi-public; but they saw that similar powers to those sought by the measure had been granted the solicitors, medical men, dentists, and even patent agents. The Legislature, in his opinion, had been strangely neglectful of the interests of the architectural profession. It ought to be made clear that by adopting registration great benefits would accrue, not only to the profession, but to the public. The President, in responding, said he fancied it was difficult to place the case of registration before the profession in a new light; but he emphatically denied that the members of the society desired to establish a monopoly by the passing of the Registration Bill. All they asked was that in the future those who proposed to enter the

THE SOCIETY OF ARCHITECTS' DINNER.

THE annual dinner of the Society of Architects was held on Thursday night in last week at St. James's Restaurant, Piccadilly, and was well attended. The President, Mr. Walter Emden, J.P., L.C.C., occupied the chair, and among the company present were the Earl of Jersey, G.C.M.G., Lord Welby, G.C.B., Hon. W. F. D. Smith, M.P., Sir David Evans, K.C.M.G., Mr. Ernest Bond, M.P., Mr. H. Atherley-Jones, Q.C., M.P., His Honour Judge Emden, the Rev. Dean L. G. Vere, Mr. Edward Bond (chairman Technical Education Board), Mr. Robert Walker, J.P. (ex-president), Mr. E. J. Hamilton (past-President), Mr. F. S. Kenyon, Mr. Charles Martin, Mr. S. W. Thompson, Mr. R. Walker, jun., R.E.; Major F. Seymour Leslie, R.E., A.S.E.A. (vice-president), Mr. Silvanus Trevail (vice-president), Mr. Ellis Marsland (hon. secretary), Mr. H. G. Quartermain (hon. treasurer), Rev. A. Mercer, Rev. C. A. Berry, Mr.

profession should not do so without affording some guarantee that they could pass a properly-qualified examination. He was astonished at the apathy and opposition with which the introduction of so obvious a desideratum as the Architects' Registration Bill had been received; but perhaps one reason was that, until the society was established more than fourteen years ago, no body of architects raised the question. But since its formation the Registration Committee had earnestly endeavoured to call public attention to the need for this desirable reform. The public did not realise that at present anyone who could afford to buy a brass plate could call himself an architect, and could undertake the erection of a building without any training or knowledge whatever. It had been said that the artistic side of the profession would be injured by having to pass a qualifying examination; but an architect's artistic powers were no more liable to be injured by his being compelled to give evidence of a knowledge of construction and sanitation than the inventive qualities of a painter were lessened by his being taught anatomy. In no Continental country were architects placed in the same position as in England. He trusted they would soon be able to carry the Bill through. Mr. Ellis Marsland proposed "The Registration Bill Committee." In a few terse sentences he sketched the history of the registration movement, remarking that the committee was formed in 1886, and that its policy had been a three-fold one of watching, working, and waiting. The Society of Architects had taken a very active interest in the movement, which was gaining ground, especially in the provinces, largely as the outcome of meetings held at Cardiff, Bristol, Leeds, and Newcastle. The committee had met with some opposition; but no arguments had been advanced against the proposal, and the greatest difficulty was the apathy of members of their own profession. Mr. Robert Walker, of Cork, past-president, responded for the committee in an able and eloquent speech. The remaining toasts were "The Visitors," proposed by Mr. Trevail, of Truro, and responded to by Judge Emden; and "The Press," proposed by Major Leslie, and acknowledged by the representative of the BUILDING NEWS.

#### THE ARCHITECTURAL ASSOCIATION.

THE ordinary fortnightly meeting of the Association was held on Friday evening at 9, Conduit-street, W., the President, Mr. Hampden W. Pratt, F.R.I.B.A., in the chair. Two nominations were read, two former members, Mr. F. W. Macey and Mr. H. H. Smale, were reinstated, and, on the motion of Mr. G. B. CARVILL, hon. sec., a vote of thanks was passed to Mr. F. B. Wade for permitting members to visit Lord Windsor's house on March 26th, and to Messrs. Spalding and Cross and Mr. H. T. Hare for permitting members to visit the Shore-ditch Public Baths and Free Library on April 2nd, and to Mr. J. E. Wakeling, J.P., for conducting the party over the baths. Mr. E. HOWLEY SM, hon. sec., reminded members of the concert to be held on the following Friday (to-night) at the Café Monico, Piccadilly-circus. The President announced that the following classes were about to commence:—Mr. Weedon's Water-Colour Class on Saturday, May 7, 2.30 p.m., at 56, Great Marlborough-street; Mr. A. O. Collard's class on "Professional Practice" on Monday, May 2nd, at 6.30 p.m., also at 56, Great Marlborough-street; and the Sketching and Measuring Class would hold its first meeting at South Kensington Museum on Tuesday, May 3rd, at 6 p.m. The next spring visit, Mr. Carvill stated, would take place at 3 p.m. on Saturday, May 7, at the new Crown Theatre, High-street, Peckham, by permission of the architect, Mr. Ernest Runtz. Some donations to the library were acknowledged, with thanks.

#### THE HOUSE LIST

of nominations for officers and council for the ensuing session was read by the President, that of the suggested President Mr. G. F. Fellowes-Pryne, and vice-presidents, Messrs. P. J. Marvin and A. S. Flower, F.S.A., being received with applause. It was explained that any two members might, if they desired, nominate others willing to serve at the next meeting to be held on May 6; but the assent of the gentlemen nominated must be obtained.

#### THE MORALITY AND ECONOMY OF COMPETITIONS.

The following paper on this subject was read by Mr. H. B. CRESSWELL:—Some two years ago I had the honour to contribute to Architectural Association Notes a series of articles in which the subject of architectural competitions was lightly touched upon. Certain figures relating to the number, value, and dimensions of public competitions were assumed as fairly approximating to the real ones, and it became manifest that the competition system, when viewed from the basis afforded by these figures, was irrational in the extreme. In spite of the popularity of competitions, it seemed that the whole fabric of them constituted for the profession an inconceivable folly, and accordingly the results and conclusions ensuing from these assumed figures appeared incredible; but as these figures were certainly within the limit of fair supposition and probability, it struck me that if the actual statistics could be obtained and exhibited in their true significance, our competition system could be demonstrated to be at once futile and disastrous, both to the interest of the profession and to the art of architecture, and the system accordingly fell to utter disrepute. One was quite unaware that as early as 1838 a special committee of the Institute had investigated the matter in detail; and that 20 years ago the same idea had urged the late Mr. Thomas Porter, a Fellow of the Royal Institute of British Architects, to proceed upon the same lines that had been laid down for this paper. I found I had elaborately taken my apple-cart to an orchard where the trees were already stripped. Mr. Porter made an exhaustive investigation of the facts and figures relating to competitions, and clearly demonstrated and established the

#### FUTILE AND DISASTROUS

character of the system; but, so far from his revelations bringing competitions into disrepute, they would seem to have stimulated the promoters to new and more extravagant irregularities, and the competitors to a keener rivalry. One duly discovered the existence of Mr. Porter's elaborate tables only when one had gone far towards completing just such a series of tables oneself, which was to a certain extent unfortunate, because Mr. Porter's figures are most carefully verified and completely established, and prove those points which they deal with, and a great deal of one's own investigation must therefore seem largely superfluous. After what has been said, it would be well to recapitulate the

#### HISTORY OF THE VARIOUS PROTESTS AND OBJECTIONS

that have been raised against the competition system in this country. Organised and systematised protests against the system date from quite early in this century; and, for the better part of a hundred years at least, the voices of ingenious architects, defrauded in open competition, have been heard in choruses of lament, mutually, at the tyranny of rural shopkeepers, and combining to make public protest and demonstration just as they are to-day. I have noted the following instances and occasions; but no doubt there were others which have not fallen under my notice. In 1838 a committee was appointed by the Institute to consider this subject of competitions, who, having thoroughly investigated it, seemed appalled by its difficulties, and concluded by publishing a report containing much "valuable information, but leaving the remedy very much as it was before in the hands of the profession." In 1850 the Architectural Association considered the question, and drew up a report containing a code of regulations, which it was suggested would meet the difficulties of the case. In 1857 Mr. George Morgan read a paper before the Institute upon this subject, which led to a debate, in which everyone agreed again that something ought to be done. In or about 1860 the "Architectural Alliance" took steps to draw up a form or circular suggesting terms of "general conditions," which were sent to such committees and councils as showed symptoms of breaking out into competitions. In 1871, on the occasion of the General Congress of Architects, Professor Kerr read a valuable paper on the subject of the commercial aspects of competitions. Everyone agreed that something ought to be done. A special committee was again nominated and deputed by the Congress to investigate the matter and report accordingly. In 1872 this report, together with a code of proposed regulations for the conduct

of competitions, was read before the Congress of that year, and the Congress were, with one exception, unanimous in agreeing that something ought to be done. The exception was Sir Edmund Beckett, who made a very able and interesting speech in the character, as architects may consider, of devil's (or grocer's) advocate. They are the recommendations of this same report, revised again in 1883, which to-day stand in the back part of the Institute *Kalendar* as "Suggestions for the Conduct of Architectural Competitions." In 1879 Mr. Thomas Porter read his exhaustive paper on the subject, in which the best that has been said in demonstrating the suicidal folly of the profession in acquiescing in the competition system is there printed and set down. After hearing that paper, everybody was as completely satisfied as they had ever been that something ought to be done. It was a past president of the Architectural Association, Mr. Cole A. Adams, who the next year did—or very nearly did—the necessary "something" by drawing up and circulating a

#### MEMORIAL,

which was signed by 1,300 architects, who thereby bound themselves to take part in no competition save where a "professional adjudicator of established reputation was employed." This was presented to the Institute by the late George Edmund Street in 1881, when the subject was again discussed. It is indeed a cause for regret that the activity aroused by Mr. Porter's laborious investigations, and organised by Mr. Adams's energies, should have been allowed to burn itself out without profit to anyone, because it was the occasion of a revelation of such importance and significance as is not likely to occur again, and the fact of this enterprise having failed to any substantial purpose, sets the profession in a much more hopeless position than if the endeavour had never been made. While, however, the Special Committee of 1872 found that professional assessors were rarely employed, I find that in the present day more than half the competitions avail themselves of the services of such an assessor. There is no reason to suppose that this is not a direct result of Mr. Adams's memorial. Nevertheless, when such a momentous occasion has wrought such a small benefit, how can we hope other men to interest themselves actively in a reconstruction of the system? Still, as far as one is able to judge, the Institute, and indeed the profession in general, is as firmly convinced as it was in 1838 that something ought to be done, which is a matter for congratulation. The subject came up again when in 1883 a special committee of the Institute was appointed to revise the regulations for conditions of competitions drawn up in 1872; but I am not aware that it has found any prominent or special attention in the fifteen years intervening, so that there seems some reason for the conclusion that the failure of Mr. Porter and Mr. Adams in 1881 has unfortunately tended to relegate the subject to the great limbo of the hopeless causes. But there is hope. We have seen that in 1838 the Institute debated this subject, in 1858, in 1871, and 1872; and in 1881 and 1883 it held debates and read papers on the same subject, and if, therefore, things continue in the world of competitions as they have been doing for the past few years, it seems a reasonable ambition to hope and expect that the Institute will shortly read another paper to itself on the same subject, over again, and draw up some fresh reports and some more suggestions. Of the figures which are here presented for the first time, they have been modified from what was originally hoped and intended of them. It was found impossible to discover the actual number and value of all competitions in Great Britain over such a period as should afford an unquestionable average figure of competitions in any one year, because a large proportion of competitions are only advertised locally. In England alone, more than half of all competitions are not advertised or noticed in the professional journals, and both in Ireland and in Scotland the tendency is to preserve and confine competitions to their respective countries, a circumstance for which, under existing conditions, we can scarcely be sufficiently thankful. One is inclined to predict that, if these two countries opened their doors, and our voracity for competitions did not flinch from the new undertaking, the profession would fall limb from limb and rot away. The figures and facts hereinafter dealt with, therefore, must be regarded as having reference to England



only, but even here they are inadequate to give any idea of the magnitude and extent of the system, for the already-stated reason of the inaccessibility of local statistics. It is upon the basis of averages that the subject is to be here dealt with. The system has manifest advantages over that in which special cases are enumerated. It is a fairer method, because in dealing with so wide a subject a selection of special cases can be made to illustrate any assumption or point of view, and prove any desired conclusion. It is clear, because it condenses the whole field of the subject to a single representative item, and reduces the whole matter to its vital and primal element. It is absolutely necessary in considering this subject of competition to regard it in its wide and general bearing as affecting the profession and the art, if any profit is to derive from that consideration. To investigate it from the point of view of the individual competitor, and with an eye to his personal welfare or disadvantage, is scientifically absurd, besides being obviously unwise in many other ways as well. There is little doubt that

#### THIS HORRIBLE INCUBUS OF COMPETITIONS

which torments the profession would never have grown to a serious harm if we had considered the matter in its universal and general bearing, and not in its personal and particular aspect. Competitions, therefore, will here be dealt with in relation to the profession as a whole, and a scheme of average is used as being most serviceable to that end. In the years 1894 and 1895 there are some seventy-one advertised public competitions, or, say, thirty-six advertised in each year. The average value of a building for which competitive designs are publicly invited is £9,000, so that the value of the buildings whose designs are made in public and advertised competition is something over £324,000. The average value of the first prize (and premiums may be considered to be always offered, though there are solitary exceptions) is £56, and besides a sum of £52 is divided in smaller prizes. The average number of competitors I find to be about forty. Now the

#### COST OF MAKING THE DRAWINGS

in a competition of the value of £9,000 may be fairly put at £30 for an average case, being eight drawings at £4 each. This sum does not cover the time of the principal, but the actual cost of producing the drawings. It is true that this cost cannot be at all exactly stated because the amount of work put into competition drawings varies considerably, for obvious reasons. It is, however, a fallacy to omit in computing this cost such items as rent, light, and general office expenses, on the ground that they would have been incurred in any case; and it is wrong to consider that, because the principal makes the drawings with his own hand, they have cost him nothing. If he had done this amount of work for some employer he would have been paid, and by doing it for nothing he may be considered out of pocket to the extent of the value of the work. Indeed, he has probably lost more than if he had employed an assistant, because, had he chosen to work for his hire he could command a higher price than what he would pay his draughtsman. The Special Committee of 1872, already referred to, stated in its report that the cost of producing competition drawings (irrespective of principal's time) varied from  $\frac{1}{2}$  to 20 per cent., and from £2 to £800, so that an assumed average of £30 in a competition of £9,000 seems well below the mark. This figure gives an average expenditure by architects of £1,200 upon each competition, or an out-of-pocket loss in each year of £43,200. I find a slight decrease in public competitions in the last 20 years; but this seems more than balanced by the mass of limited and local competitions. I am not going to amplify and emphasise the

#### SIGNIFICANCE OF THESE FIGURES

further. But I claim for them that they establish and demonstrate our competition system to be commercially rotten and unsound—that it is irrational, that from an economic point of view it is a monstrous anomaly, and that it is the occasion of expense and extravagances which could hardly be justified even if the policy of the system was shown to be widely beneficial to the dignity of the profession and the distinction of the art. This, however, is not the case. Our system of competition as a policy is so disastrous to the status of the practitioner, and so enervating to the art itself, that even if the economic considerations

were satisfactory, and the system beneficial to the pockets of the profession, it could still be shown desirable that the system should either be abolished or entirely reconstructed. This question of policy may be considered quite apart and aside from the economic question, which we have now done with, but it is necessary to explain that the remarks and the conclusions professed in this and the following columns do not refer to those large public competitions for valuable and important buildings which are published and discussed by us all; but to the general ruck of competitions, including limited and local competitions, which are here designated and included in the term of our Competitive System. Public competitions for national and monumental buildings, in which the best-established and most reputable of our architects take part, must ever stand in a very different light, and be viewed with a very different sentiment from that which is accorded to the wild, tumultuous disorder of the common herd of competitions. It seems to be assumed by many people that competitions are a means to the end—building. This, of course, is not the case. This complex mechanism of public competition exists solely to determine which precise architect shall be employed to carry out this or that individual work; and after fifty years of this struggling and grunting and tearing and fighting among ourselves, it is still found that the architects of England have raised England's architecture—precisely the same state of things that would have been effected without competitions in peace and goodwill. Our competition system has crowded the profession, and crowded it very largely with ineptitude. In these days we all go in for the grand handicap for premiums before we know how to run. It is a scramble wherein all sorts of unlikely people come in first. The opportunities for a young man to find a standing in the profession by a single stroke of good fortune induces many to enter the profession who would not dare to face the long stern path by which alone success is usually to be sought. They are dazzled by a game wherein success relies so little upon sterling ability, and so much upon the chance circumstance of prejudice and bad taste in ignorant people. The

#### POLICY OF THE SYSTEM IS DETRIMENTAL

also to the art of architecture, as well as to its practitioners, because it effects that the selection of architectural designs shall be made precisely by the class least qualified to form a right judgment. The class who acquire the right of selection under the system—the hanging committee in the gallery of architecture—are not merely ignorant, but they are saturated with the most blatant forms of vulgarity. Our competition system has secured that a large and important division of our national architecture shall interpret and immortalise the ideals and aspirations of precisely the intellectually most degraded and insignificant class in the country—a class that is educated in positive ignorance, and cultured to execrable artistic proclivities and tastes. It is not, unfortunately, a case merely of callousness or indifference. The rural town councillors of remoter England positively select with a rare pains and discrimination the worst designs—not merely or necessarily the most hideous and ineffective, but just those which are most laden with studied assumptions they cannot support, which pretend to qualities above their kind and station, and which cry out their sham importance—precisely those designs which are least fitted to exist, which most insidiously degrade and pollute the morals of all who pass beneath their walls. The custom is to speak in fulsome terms of the ennobling influence exerted upon the mind of man by true and refined architecture of lofty aspirations. If this be a just and true estimate of the potency of architecture to influence and modify the ever-changing moral tendencies of a people, and I do not think many will dispute it. We are entitled to apply the reasoning to the other side of the picture, and turn our attention to the false and mean qualities which characterise the greater part of our architecture. What horrors of infamy there do we not see being daily inculcated at our street corners, gentlemen, and what iniquitous deeds must be those performed in the trades of our bricklayers, masons, and carpenters! And of these insidious stimulants to moral degradation which are daily rising inch by inch throughout the country, some of the most evilly-intentioned are those raised in public competition. The influence of these to undermine the pure

motives of humanity in those whose life is spent under their shadow, is the stronger and the more to be deplored, since the buildings hold a significance in being for the most part public edifices, the property of the township. The sermon of these stones is preached from an authorised pulpit. It is sufficiently melancholy that that class which, as has been said, is cultured in a positive ignorance of matters related to art, and which is permeated with the undignified instincts and ambitions of small trades, should hold the privilege of perpetuating these deplorable instincts and ideals in the majority of the public monumental buildings in England; but it is a great deal more melancholy that architects (in acquiescing in a system of competitions which grants these unfeeling creatures the choice of some forty designs) should have added the privilege that enables them to secure a design which portrays their own meagre commercial instinct and their motives of brag, assumption, and self-advertisement much more thoroughly and effectively than any could reasonably have hoped to obtain from a private architect. It is true that an assessor is most usually appointed, but it is certain that

#### THE ASSESSOR HAS LITTLE AUTHORITY

with the average town council upon a question of design, and nearly all conditions of competition expressly state that his award is not held binding upon the promoters, as will be shown hereafter. The tendency of our deformed system is to secure that a great deal of architecture is soundly and thoroughly vile which otherwise might have been merely weak and poor. In view of our unfortunate condition, it is curious to read of the architects of Belgium, who, in and about the year 1887, were desperately concerned to secure this same usage of public competitions which we would now be quit of. The traditions of the profession in Belgium had been opposed to competition. However, the "Central Society of Architecture" at the outset decided that "if competitions were to give good results, they should be properly organised," and upon this understanding it is interesting to notice the recommendations on behalf of the policy of competitions as stated in a paper read before the society in 1887. "The advantages of the system," said the speaker, "are thousandfold. It enables artists to make their talent known. It does away with favouritism. It is an arrangement essentially moral, equitable, and just. It permits the inclusion of all ideas, ancient and modern. All schools—Gothic, Renaissance, Classic—may be set before the public and their value known. A constant emulation is provoked; it stimulates travel and study, and gives all a legitimate right to see their efforts crowned and their talents recognised." These are the terms in which a brother architect has advocated the policy of a properly-organised system of competitions; but if we put our own system to the test of these various recommendations, we shall find that, so far from showing the advantages of our system,

#### THE DISADVANTAGES ARE PROVED.

Our competition system assuredly does not do away with favouritism; we have abundant evidence to show that it provokes it. A set of competitive designs is an assurance to the promoters that their favourite is not incompetent; he has shown up with the rest. It is an arrangement essentially neither moral, nor equitable, nor just. It may certainly permit the inclusion of all ideas, both ancient and modern, and, for the matter of that, demoniacal as well, but the system allows and indeed promotes a lax and unreserved treatment in design, and in this country it is restraint and not freedom that needs just now most to be promoted. A constant emulation is indeed provoked; but it is not an emulation in knowledge, in style, or power of true expression, but in a smart clap-trap meretricious knack of design. Lastly, it cannot fairly be urged as a recommendation to our competition system that it enables artists to make their talent known. There are men of proved quality who have found their opportunity in competition, but it still remains to be shown whether they would not have established their ability just as effectively and as effectually had they abstained from competition, as Pugin, Nesfield, and Mr. Norman Shaw have done. There are many notable instances of men of the highest reputation who owe nothing to competitions, and some who have altogether abstained from them. There is a general approval of competitions on the ground that

they give young men an opportunity of showing their worth. One has heard them called "the young man's friend," a touching phrase, which, however, lost in pathos from being employed by a young man who wins competitions. As, however, a young man must look to compete forty times for every first award he wins, we may rather consider them as the "young man's enemy," for it is appalling to think of the host of young men who have thrown away their best energies and hopes in the preparation of useless drawings. These waste drawings, accumulated for a period of twenty-five years, Mr. Porter computed would pave a way from this room to Grantham, or their strainers, lying one on top of another, make a tower 1,000ft. higher than the highest mountain in the world. This computation is far below the actual facts, however. The great names in art are not altogether those of men who have risen to acknowledged supremacy in early life, and early success is usually vastly detrimental to the artist. The very essence of true power is that it shall come of long vigils of self-denial and long years of self-contained labour. A genius usually has to make his own public. In these days the matter for remark is not slow acknowledgment of worth, but rather the numbers of men who spring into superficial notoriety, and who are never again heard of, or whose names are never associated with any admirable or commendable work. This is because men spring into notability upon specious and meretricious qualities. Merit is content to wait; demerit is not. The men who are most successful in their professional life, in their art, are those who start without fallacious incentives, false aids, and without haste, and without greed of those rewards of acclamation and patronage which is the gift of the discerning British public. It is a common usage to exclaim against the promoters of the competition when there has been

**INEQUITABLE TREATMENT OF THE COMPETITORS,**  
or a precedent has been made in the new irregularities. This, however, is unreasonable. Competitions are not a matter of philanthropic consideration—there is no suggestion of philanthropic motives or of mutual concessions for mutual benefit. In any other transactions involving such large outlay, and such weighty consequences, the architect, in common with his fellow-citizens, protects himself according to commercial usage, and there is no reason why he should make an exception in the case of competitions. A town council desires something, for which it is prepared to offer certain moneys or advantages, and architects, by accepting those terms, have committed themselves beyond dispute as being satisfied with them. The promoters, regarding the matter solely as a commercial or business enterprise, can only suppose from the rivalry and enthusiasm the competitions evoke that they are esteemed and valued of the profession. It is no conspiracy on the part of the public, or the promoters, that led to this lax and lamentable state of affairs, but a conspiracy of greed and weakness on the part of the profession.

**THE FRAMING AND ENACTMENT OF COMPETITIONS**  
is, as has been said, purely a matter of business and of commercial enterprise. Upon no other basis is their existence intelligible. There is no question of philanthropic motives, nor of a mutual scheme for mutual benefit. The conditions of competition as now drawn up may be in general very fairly described as a sham legal instrument; it is a sham form of contract wherein the obligations of the competitors are clearly and exactly defined, and the obligations of the promoters set in such loose, ambiguous terms as to render them open to any interpretation that subsequent events may show to be most profitable to the promoters. The conduct of a public or limited competition is clearly a matter of contract, and it is the business of each party to see that his interests are properly protected in its terms. It is, therefore, weak and foolish for competitors to cry out and protest when they find that they have the worst of the bargain. It is usual in such cases to charge the promoters with having broken their word, with having falsified their explicit undertaking; but surely redress for such injury as is here claimed lies not in the sympathetic columns of the professional Press, but in an action at the High Court. The truth is, however, that it is very rarely that promoters of competitions go back on their precise undertakings or falsify their explicit promises. This is not for any qualms of senti-

ment or conscientious scruples, but for sheer lack of any precise undertakings to go back upon, and utter dearth of any explicit promises to falsify. When an assessor's award is set aside, or when the winner of the first premium is supplanted in his commission to do the work, there are invariably long and loud protests; pathetic appeals to common honesty and fair treatment from us poor architects, who forget our greedy rivalries for the moment, and are bound in one common sympathy of misfortune. Someone read a paper once on "Professional Etiquette." One does not think it could have been unduly long. This common misfortune may be described as the only bond of sympathy still existing among us. But to keep to the subject of conditions of competition, I have drawn up a table which enables me to substantiate what I say. This table gives the gist of 37 conditions and instructions, as sent to competing architects, taken haphazard from the portfolio lately instituted for this purpose in the library of the Royal Institute of British Architects. Upon this basis I find that in 50 per cent. of cases an assessor is appointed; that in 77 per cent. the premium merges in commission; that in no case is the winner of the first premium promised the work, but that, on the contrary, 54 per cent. state that the committee is "not bound to accept the first award," and 35 per cent. state that they do not bind themselves "to accept the first or any design." That in no case is the assessor's award stated to be absolute; but that, on the contrary, in 100 per cent. (estimated on a basis of thirty-seven returns) of the cases it is expressly stated or clearly implied that his award will not be absolute—that the committee do not hold themselves bound by his decision. I may also call your attention to other little delicacies offered, where the thoughtfulness of promoters is again instanced. In order to mitigate the fevered enthusiasm and passion of emulation with which they have noticed we fling ourselves into competition, they have docked the commission in some 16 per cent. of the cases by making the 5 per cent. include quantities of other extraordinary expenses. I also discovered five cases where no conditions existed at all, and also a little gem, where there was no premium offered, and yet another, where the ten-guinea premium was to merge in commission if the work was carried out within five years. And now we come to put the finishing feather in the cap of the guy which the profession has manufactured and parades before the derision of all sensible people. Although these conditions are so monstrously unreasonable, prejudicial, biased, unbusinesslike, and unfair, nearly all of them have been ratified and approved, if not actually

**DRAWN UP BY A PROFESSIONAL ASSESSOR.**

—an established architect of position and usually of reputation. This state of things is opposed in spirit and in detail to the "Suggestions for the Conduct of Public Competitions," published in the Institute *Kalendar*. It is hardly fair, however, to hold assessors individually responsible; for it is the common usage, the custom of the profession. Every competitor, we know, would be an assessor if he could; and it is not to be expected that a man should martyr himself in a cause where his individual self-denial would work no good, and for which he would receive no thanks or even recognition, but it is indeed deplorable that such a state of things should exist. How are architects, in the face of this corruption, which they sanction and maintain, and even promote, to support any attitude of dignity and integrity for the profession in the eyes of the public? Is it to be marvelled at that a young architect is expected by his first clients to work for nothing? We most of us have been invited to dinners as though we were being asked to dinner. Some time ago it was under heated discussion whether architecture was an art or a profession. I believe the matter was not altogether definitely settled, but for one's self, as it has altogether failed as a profession, one is bound to consider it an art. When, however, we travel behind the scenes of our competition system, the matter would seem to resolve itself into the question: Is architecture an aberration or a vice? In the general ruck of competitions not one grain of professional or artistic enthusiasm has place—if enthusiasm may be estimated in grains. The desire to compete is born of unrest, worldly ambition, weak unbalanced inclinations and false hope, bred of an incontinent longing for the plums of life before the just harvest time: to be got,

not legitimately, but by a short cut. Everyone knows that the

**KNACK OF WINNING COMPETITIONS**

is not the knack of design. Even Sir Gilbert Scott admitted that his designs made in competition were necessarily different from those he would have made for a private client. Professor Kerr had insisted that the man who rises is the man who gets the best information from the best source. The ordinary competitor does not think of consequences, or he would not compete. He is buoyed by excitement; and it is this memory of his intoxicating excitement which prompts him and seduces him to further risks. It is no use or purpose to show him that it is forty chances to one against his winning—any more than it is to tell these things to the gambler or the betting man. The whole circumstances of the ordinary architect in competition is that of a gambler making a big stake. The central idea, originated in the principal, reverberates through his surroundings. A common way for a competing architect to pay for assistance in his competition is by a promise of double or treble pay to those who assist in the event of his success. They all contribute on the understanding that they share the prize money. These sorts of transactions are common enough on the turf. Architecture, however, is a profession. One once went to visit some friends who were in for a competition. One called as usual at midnight. Their rooms were full of men, mostly in their shirt sleeves, cleaning and finishing up the drawings. In a corner a young quantity surveyor was getting out an estimate like a man possessed. There was also a frame maker, blocking two doors and a passage-way. Excepting the frame maker, possibly the whole crew were banded together for the excitement, the glorious uncertainty, and the chance of treble pay and long drinks if the principals came in winners. Architecture, however, is an art. The whole atmosphere and environment of competitions is corrupt. I know personally of a competitor who was approached frankly—unreservedly—indecently—by a member of a promoting committee in a late competition. The committee-man inquired whether he wished him to work for him on committee. The whole unruly surroundings of competitions are opposed not only to professional dignity, but to the ordinary natural sensitiveness and reserve of a gentleman. This is how one would have an architect to regard the matter. He should apostrophise thus: "My worthy grocer man, I will design and build you your bacon larder, or your genteel residence, with its gewgaws and furbelows, and thank you for the commission; but I will not struggle at your door with forty others, to submit my knowledge to the verdict of your ignorance and put my cultivated taste to the test in the balances of your cultivated vulgarity." Can anyone believe, until he has eradicated from his mind the whole field of competitions, that architecture is either a profession or an art? Let me tell you the true and fascinating story of Durham; it is not a very old story, but it will bear a lot of re-telling when we wish to be stung to a recognition of the melancholy status of the profession. I especially tell the tale in reference to the question, Is architecture a profession or an art? It will be observed that it is a case which rises out above the general run of competitions to which my remarks heretofore have had reference. In other words, it is an exceptional case, above the average in value and importance. To begin with, any architect entering for this Durham competition, promoted by the County Council of Durham, had to pay a fee of £5 before he could know upon what precise terms he was to be humbugged. This is a common expedient with promoters to stave off the first mad rush of architects. The assessor selected six designs, from which he made the final selection of his awards. The committee paid the first premium, awarded a local architect the second premium, and gave the latter the commission to execute his design. This local firm's design was stated not to have been included in the six designs of the preliminary selection. Then the profession made a strong stand. It got right on its hind legs. It objected. It objected in the professional Press; it objected in printed circulars sent to the council. Fourteen of the competitors signed this circular-letter, praying that the winner of the first premium should be appointed to execute the work. They also pointed out that not only was the local firm selected by the council not included in the first

THE AVERAGE ENGLISH PUBLIC COMPETITION.

Computed from the basis of seventy-one English Public Competitions advertised in the years 1894-5\* ; and from an analysis of thirty-four "conditions of competition" (see other table).

Value.	Premiums.	Competitors.	Promise of Assessor.	Premiums to merge in commission.	Promoters "not bound" to accept "1st award."	Promoters "not bound" to accept "1st or any award."	All Premiated Designs Property of Promoters.	The 5 per cent. commission to include extraordinary expenses.	Assessor's award admitted to be absolute.
£9,000	1st £58, other prizes to value of £52.	40	Over 50 per cent.	54 per cent.	54 per cent.	35 per cent.	73 per cent.	16 per cent.	Practically never.

\* It is not meant that each item has been worked out from seventy-one cases. Full particulars of every case were not to be obtained, but the number of cases yielding each figure was sufficient to guarantee accuracy for round numbers.

six, but that his design should, under the conditions of competition (for the luxury of which they had staked £5 each), have been disqualified. This memorial was sent individually to each member of the council, shortly before the meeting which was to make the final irrevocable decision, with the intention, we may presume, of sapping their native resolution with such a show of firmness. Our powers of objection now became almost inspired, and certainly beyond human precedent. Two of the competitors, solemnly appointed and deputed by vote of them all, went and took residence in a hotel close by the building in which the council were to meet. Think of it! Two live competitors at hand, in a hotel, in person, to bring shame to the naughty councillors! Notification that these two protesting professionals were actually *in situ* at the hotel was duly sent to the council. One regrets to say that there is no evidence of the council having winced in bulk at this ominous news. We can fancy the pallor-stricken subordinate official bursting upon the elect councillors of Durham with the extraordinary intelligence. One has tried to realise the terrorising effect, or the persuasive influence of a brace of protesting architects in a hotel, inviting there inspection and examination from the townspeople. One has altogether failed. One can hardly picture anything funnier. Our profession is content to go out to battle with a glass tube and a mouthful of rice, instead of having recourse to the solicitor's letter, which is usually employed. The result of this venture was that the council said that they claimed legal right on the conditions of competition, and, further, that the disqualifying features in their awarded design had not been brought under their notice, while a noble Lord who had got washed up on to the council in the late high tide of municipal aristocracy, denounced the protesting brothers' cause as "a professional squabble." What else than something of this kind we could have expected to get from the council it is not very easy to imagine. The protesting brothers seem to have appealed to the council's sense of justice, to its goodness of heart, and so forth; which, in face of the printed regulations accepted open-eyed by each competitor, was quite beside the mark, and an affront to both the understanding and the feelings of the council. Apparently the deputation of protest expected to be answered somewhat as follows: "Gentlemen, we have been touched by your appeal to our good nature and sense of poetic justice, and though we were careful in the 'conditions' to secure a free right to appoint whoever we might choose, yet your eloquence has shown us so clearly how base and shameful our motives were, that we herewith withdraw our decision, and agree to do what you wish." Unfortunately, side by side with our champion objectors' words of appeal, was the complacent admission of the assessor, who told the council that "of course they were not bound by his award." And now, gentlemen, bearing this scene in mind, is architecture a profession or an art?

A GREAT NUMBER OF SUGGESTIONS

have been made for the amelioration of reorganisation and reconstruction of competition, but, so far as I know, no one has suggested that we should, in the matter of competitions, individually regard architecture either as being a profession or an art, or both, and that we should return to that attitude of independence with which it is hoped most of us left school or college, and which was ours before we were enticed to the attitude of the emulative haberdasher soliciting someone's valued order. We are wont to deal with matters relating to a private commission from a quite different standpoint to that from which we regard competitions; but I think few of us will deny that the wide generality of local competitions has spoiled our

clients; and I think you will agree that the ordinary man who has not the advantage of a private fortune or a circle of the right sort of friends is almost compelled to submit to the humiliating treatment from his prospective clients. For my own part I feel strongly against turning the profession into a sort of trades' union, yet most of the remedies which are suggested imply that or tend to that end. The matter lies in our own hands. Our disordered competition system is a monument to our incontinent unthinking

indeed, Mr. Cresswell left the subject very much where it was before—namely, that "something" ought to be done to improve the conditions of competitors. He had, indeed, listened very attentively to his eloquent peroration, but did not arrive at any definite conclusions. He knew the late Mr. Porter very well indeed, and remembered that Mr. Porter very often entered into competitions himself, although he held, as they had heard, strong views as to the morality of the competitors. They knew the old saying that there were such

ANALYSIS OF THIRTY-FOUR CONDITIONS OF PUBLIC COMPETITION, AS ISSUED TO COMPETITORS, TAKEN AS THEY CAME TO HAND FROM THE PORTFOLIO AT THE LIBRARY OF THE ROYAL INSTITUTE OF BRITISH ARCHITECTS.

Limited or Public.	Value.	Premiums.	Assessors?	Premium to Merge in Commission.	First Award to Execute.	Drawings Property of Committee.	Assessors Absolute.
P.	—	50:20:10	1	Yes	Not bound	1 Yes	No
P.	Rough Spec.	20:10	1	Yes	" "	1 and 2 Yes	No
P.	500	10:5	?	Yes	" "	1 Yes	No (5 per cent., including quantities)
P.	(over 9,000)	50:25	No	Yes	" "	1 and 2	No " " "
P.	4,000	30:20:10	Yes	Yes	" "	1, 2, and 3	No
P.	3,500	25:10	No	Yes	" "	1 and 2	No
P.	1,800	20:15:10	Yes	No	" "	1	No
P.	30,000	100:50:25:15	No	Yes	" "	1, 2, 3, and 4	No
P.	5,000	30 and 20	No	Yes	" "	—	No
P.	15,000	50:30:20	Yes	Yes	" "	1, 2, and 3	No
P.	5,000	30:15	Yes	Yes	Yes: if competent	?	No
P.	—	20	No?	No	Not bound. Nor any Designs only asked	1	No
P.	2,500	20:10	No?	?	Not bound	1 and 2	No
P.	16,000	75:50:25	Yes	Yes	Not bound	1, 2, and 3	No
P.	—	None	No?	?	" "	Yes	No (5 per cent., to include travelling, attendance at board, extras on contract, &c.)
P.	300	7:10:2:10	No	?	No mention of execution	1 and 2	No
P.	—	—	—	—	No conditions	?	No
P.	7	20:10	No	Yes	Not bound. Nor any	1 and 2	No (5 per cent. No expenses)
P.	5,500	50:35	Yes	Yes	" "	1 and 2	No
P.	?	150:100:50	Yes	Yes	" "	1, 2, 3	No
P.	4,000	?	No?	Yes	" "	?	No
P.	?	25	Yes	Yes	" "	?	No
P.	?	10:10	Yes	Yes	" "	?	No
P.	7,000	40:20	No?	Yes	" "	1 and 2	No
P.	4,000 (about)	—	—	—	No conditions	—	—
P.	1,800	—	—	—	No conditions	—	—
P.	4,000	50:20	No	Yes	Not bound. Nor any	1, 2	No
P.	9,500	50:20	Yes	Yes	" "	1, 2	No
P.	15,000	50:25	Yes	Yes	" "	1, 2	No
P.	4,000	—	—	—	No conditions	—	—
P.	7,500	—	—	—	No conditions	—	—
P.	7,000	40:20	No	No	Not bound	1, 2	—
P.	8,000	—	—	—	No conditions	—	—

greed and folly. We have over-reached ourselves, and we must retract and amend, and bring matters back to a condition of ordered decency.

THE POWER LIES CHIEFLY WITH ASSESSORS,

because they are few, and because they are men of substance and position. It should surely be with them a *sine qua non* for their sanction of conditions of competition that the terminology is legal and free of ambiguity, and that the various clauses are fair and reasonable. There is a very strong general disinclination to enter a competition where an assessor is not employed. Let it be noticed and understood in the profession that the assessor is a guarantee, that the conditions is a legal document, and that the clauses are fair and reasonable in the circumstance (which at present is far from being the case, as we have seen), and it will soon be difficult to get anyone to enter a competition where this guarantee is wanting. This may not do much to ameliorate the radical false basis of the system, but it will mitigate its corruptions and irregularities, and it will enable these affairs to be enacted with such decorum as befits an occupation which is only uncertain whether it is a profession or an art.

Mr. ASTON WEBB, in proposing a vote of thanks, remarked that Mr. H. O. Cresswell and Mr. H. B. Cresswell had been pupils in his office; he had had the pleasure of hearing the former gentleman's inaugural address as President of that association, and now had heard the brilliant paper of the latter given that evening. He could not agree with all his conclusions, and he was afraid,

things as lies, big lies, and statistics, and he thought it would be impossible to check the statistics that had been adduced, or to test the sums really spent on competitions, but he should say that the average outlay was greatly overstated. The cost to the profession, as a whole, of competition work was undoubtedly grievous and heavy, but what were they going to do to lessen it? The memorial presented in 1881 by Mr. Cole Adams had a definite object in view, viz., to insure that in every competition an assessor should be appointed, the aim being to substitute the judgment of a highly cultivated man for what the lecturer had styled the crass ignorance of a body of grocer-men. The result of that memorial was that the advantage of having an assessor was generally recognised by those instituting a competition. Personally, he thought that architects should pledge themselves not to enter into a competition where no assessor was appointed, and should decline to compete if they were not satisfied with the assessor named in the conditions, and make their objections before, and not after, the award was made. The more particular architects were the fewer competitions there would be, and the more satisfactory would be the conditions. Young architects could not be too careful in ascertaining that an assessor had been appointed, and that the conditions had been fairly drawn up before entering on a competition; but it should be borne in mind that committees generally erred not through lack of a desire for fairness, but from absolute lack of knowledge. He was not there to defend

the system of competitions; he recognised the moral harm it had done to many men, but looking at it broadly he could not admit that it was altogether bad. It gave an incentive to exert their powers to young men, and it must be remembered that a great many men did their best work before they were 30 years of age. He would ask members to consider dispassionately what the effect of competitions had had on the development of our architecture, on architects themselves, and on the public. A system which had evolved such buildings as the Houses of Parliament and St. George's Hall, Liverpool, could not be said to have done badly; and while it would be invidious to mention more modern buildings, many of these had done much to advance the public taste. The planning and arrangement of public buildings had also been greatly improved under the stimulus of competition. As to the influence on competitors themselves, it certainly should be admitted that to encourage the gambling spirit in young men was to do them harm. As to the pecuniary loss involved, Mr. Cresswell's figures should be discounted by the recollection that a young man starting in practice had necessarily much time on his hands, and that this ought not to be reckoned in golden guineas. In recent competitions the tendency had been to reduce the labour and cost of preparing competitive designs, and if a competent assessor was appointed, the outlay in both directions could often be still further kept down. He must say that he never heard of a case in which the competitor's assistants and clerks were offered twice or three times the ordinary salary if their employer won, and he did not think such a practice existed. Coming now to his third point, the effect of competitions on the public, it would, indeed, be deplorable if private work for domestic buildings were put out to competition; but they nearly always arose where committees were concerned, each member of which would have wished to recommend a nephew, son, or friend for the job, and thus it was fairest to pit these against one another. Again, in a small town, it was not probable that a committee would obtain a better design if any other method of selecting an architect were adopted. As all architects asked the same price for their labour—5 per cent. on the outlay—it was doubtful how an untried man would get his first commission except in open competitions, since promoters could go to the most highly qualified and experienced man and pay no more for his advice. It certainly afforded a great pleasure to a young architect to give his imagination and powers of planning free scope in striving to solve some architectural problem in rivalry with others. There were signs that the competitions system was dying out, and this afforded an opportunity to secure fair terms for competitors in those still instituted.

Mr. E. W. MOUNTFORD said the ground covered by the paper was so extensive that it was impossible to deal with all the points raised by Mr. Cresswell. He had, undoubtedly, overstated the cost of competition work to the younger men, and also the harm which architects, when young, sustained by going in for competitions. The time of a young architect was not so fully employed as he could wish. He would say, if a man could get enough work to employ himself without competitions he should let them alone; but the work offered to most young men when beginning practice was of a very small kind, and it was an intellectual treat to work out the scheme for a large building, even if it was probable it would not lead to a commission, and the competitor was compelled to think out and ascertain many points which otherwise he would not learn until an actual commission was in hand. If architects would compete under obviously unfair or absurd conditions, they must take the consequences. He himself was recently invited to compete for a building to cost £1,100, and, though he declined, others entered. A great deal lay with the assessor: he should be a man who had had considerable experience in the particular class of work in which the competition was being held. As a rule, assessors were thoroughly up to their work, and acted to the best of their ability. It would be well if the assessor's name was published when the competition was instituted. There were two costly classes of buildings which were not produced by competition—theatres and publichouses, and yet their architectural character was as unsatisfactory as any that could be named. He believed that the man selected by the average committee-man would be a worse architect than the one who

gained in competition, so that the system could not be entirely evil. Under it they obtained better buildings, and young architects had more opportunities for doing good work than would be the case if the competition system were abandoned. He would second the vote of thanks to Mr. Cresswell.

Mr. F. T. W. GOLDSMITH said the whole effect of competitions for good or evil depended on the attitude of the assessor. The "grocer-man" on a committee was to be pitied rather than blamed, for all his mistakes were due to the fact that he undertook to accomplish something which he did not understand. The matter was quite beyond his comprehension and that of his fellow-committeemen, and the clerk who drew up the conditions was supremely ignorant of the whole matter. If the Institute Council or the Association Committee could be brought into touch with promoters before they made the conditions public, some help might be afforded them, and good results would follow both to the profession and the public. For provincial works a committee of allied architectural societies might be empowered to take notice of any impending competition before the grocer-men had finally settled their scheme. They would all be obliged to Mr. Cresswell if he could discover and explain some method by which a representative body could get hold of promoters at an early stage. Competition would then be robbed of much of its evil. A system was now in vogue under which a series of suggestions were sent out by a R.I.B.A. committee to the promoters of all competitions advertised in the professional press, but it was obvious that when the conditions were published they could not be altered except by the assessor. In the case of one very important recent competition, it was announced that an assessor "may" be appointed. The ambiguity of this phrase was pointed out to the promoters, who substituted "will" for the objectionable word "may." Further, the promoters should be requested to publish the name of the assessor. He was sorry to see that architects of repute who had actually signed the Competitions Memorial had consented to act as assessors in cases where the conditions were not fair. Pressure had been brought to bear on the assessors in such cases, and they should be asked to give a guarantee not to act unless the conditions of the R.I.B.A. were adhered to.

Mr. BERESFORD PITE said he feared that Mr. Cresswell stood no more chance of success in warning the younger members of the profession off entering on competitions than if he had warned them against entering on matrimony. The fact was, the very uncertainty of success, the gambling spirit, made young architects eager in the pursuit of this phantom. The competition system was not only delightful, but eminently useful to the younger men, and therefore they might expect it still to be popular. It cultivated the faculty of design—the very thing the architectural student needed. Unless he practised himself in designing, a young architect would never be an expert, and the very best practice for a young man was to study the conditions of competition for some one class of building, and to work at the problem again and again, until, by continued and repeated thought and effort, he was able to evolve a satisfactory design. Since the presentation of the memorial initiated by Messrs. Cole Adams and Aston Webb as hon. secretaries to the Competitions Committee, in more than half the competitions announced an assessor had been appointed. Before the date of this well-known memorial most of the competitions were for churches or schools, and it must unfortunately be admitted by all qualified to judge that the person made a far worse assessor or member of a committee than did ever the ill-cultured grocer-man. The exhibition of the competitive designs should be insisted upon, and the fallacious character of a first premium which merged into the commission should be pointed out to the promoters. It would be very objectionable if a race of "guinea-pig assessors" should arise. It would be impracticable to abolish competitions, for everything was thereby cheapened, and although architects had retained their five per cent. commission, they had in many cases to fight for it in crowds. One great advantage in competitions which had not been alluded to, was that it demonstrated the men who were duffers and those who had ability, and it certainly quickened life in an architect's office to go in for competitions.

Mr. C. H. BRODIE supported the views expressed by Mr. Cresswell. An architect would

derive all the advantages to be gained from a competition if he prepared the drawings and did not send them in. By sending them in he degraded his profession—an assertion received with laughter and derisive applause. The conclusion of the paper was to ask the young architect not to go in for competitions; but this was perfectly futile and unattainable, for the gambling spirit which led him to enter on such undertakings would never be eradicated. He concluded by quoting three glaring cases of injustice and immorality in as many hospital competitions.

Mr. G. H. FELLOWES-PRYNNE said they had had that evening two extreme views of the subject brought before them; the two most successful competing architects of the day, Messrs. Aston Webb and Mountford, had entered the lists against Messrs. Cresswell and Brodie. He thought the suggestion by Mr. Cresswell, that the assessor should ascertain that the rules were fair was a very good one. He hoped that some good would result from this paper, and that the Institute Committee would see its way to doing more to secure fair-play. Competition existed in all arts and trades, and while it might have its evils, architects must be willing to put up with them, only insisting that experienced men were appointed as assessors.

The PRESIDENT, in putting the vote of thanks, which was carried by acclamation, remarked that the discussion had grouped itself around the question of the assessor, and he was glad to hear Mr. Mountford say that in recent years there had been no reason for complaint against the adjudicators, although this had not been his own impression. [Mr. Mountford: There has been no ground for complaint as to their honesty.] The demand that the name of the assessor should be published from the first was, he thought, straining a point. It was a decided disadvantage in some ways, for some competitors had set themselves to imitate the style and treatment adopted by the assessor. The idea that the competitors should elect the assessor was a radical reform, and would probably be satisfactory to the competing architects if not to the committee. It had even been suggested that competitors should act as their own assessors; but there were obvious difficulties in the way, especially in a provincial competition. As to the cost of competitions, he thought this had been much exaggerated, and for the outlay competitors themselves were largely to blame for their endeavours to put as much work as possible into drawings. The amount of work required should be cut down in the conditions. Something had been done in the last thirty years to improve the conditions of competitors, but they were not yet perfect.

Mr. CRESSWELL, in his reply, said there had undoubtedly been a great improvement of late years in competitions; in 1872 the appointment of an assessor was a very rare occurrence. He did not think it added to the dignity of the profession to bring it into line with the actions of glorified tradesmen. An excellent suggestion had been made that competitors should adjudicate on their own plans and should each have two votes—one of these every man would, as a matter of course, bestow on his own design, and the second he would give to that of his best friend.

#### THE R.I.B.A. COUNCIL REPORT.

THE Report of the Council of the Royal Institute of British Architects for the Official Year 1897-98, to be submitted to the annual meeting next Monday evening, states that in the course of the year 8 Fellows have been elected, 31 Associates, 3 Hon. Associates, and 9 Hon. Corr. Members. The number in each class stands as follows:—Fellows, 598; Associates, 1,001; Hon. Associates, 53. The following gentlemen have been elected as Honorary Corresponding Members:—MM. Jean Jacques Winders (Antwerp), Alexandre Charles Arthur, Comte de Marsy (Compiègne, France), Jean Théophile Homolle (Paris), El Conde de San Juanario (Madrid), Johan Louis Ussing (Copenhagen), Settimio Fedele Gerardo Giampietri (Rome), Arnaldo Rodondo Aadae Bermudes (Lisbon), Leopold Eidlitz (New York), Valère Dumortier (Brussels). The losses by death to the Institute during the past year have been numerous and serious. They are as follows:—Fellows: Arthur Baker, Daniel Birkett, W. Steven Cross, James Edmeston, Octavious Hansard, John L. Pearson, R.A., C. J. Phipps, C. J. Shoppee. Associates: Joseph Battey, C. A. Chastel de Boynville, A. J.

Forge, C. J. Gladman, George Kenyon, George H. Stone Wood, Hon. Associates: Sir Henry Orrell Bessemer, F.R.S., the Hon. Charles Alexander Gore, Alfred Morrison. Retired Fellow: George Elkington. In John Loughborough Pearson, R.A. (Royal Gold Medallist, 1880), the council mourn the loss of one of the most distinguished members of the Institute. Octavius Hansard was for many years a member of the Council, well known to most of the older members of the Institute; and James Edmeston for a number of years was chairman of the Architectural Union Company.

Preliminary and intermediate examinations were held in June [and November, 1897, in London, Manchester, Bristol, and final examinations in London. During the year 170 gentlemen have been registered as probationers, the number of whom now stand at 983; and 69 have been registered as students, the number of whom now stands at 248. The Arthur Cates Prizes for the best set of testimonies of study submitted by students for admission to the final examination have been awarded to Mr. Percy Morris [A.] for the June examination, and to Mr. Laurence Hobson [A.] for the November examination. The Ashpitel Prize has not been awarded this year. The Board of Examiners, after numerous meetings and anxious consideration, have prepared a new syllabus of the examinations. The new regulations will come into force during the June examinations. With regard to the Owen Jones Studentship, the Council report that, the value of the Studentship having gradually increased to double its former value, and the will of the late Owen Jones giving them the authority to act, they have increased the value of the Studentship from £50 to £100, and the duration of the student's tour from eight weeks to six months. They have also decided that, on his return from the tour, the student shall submit an original composition in colour decoration on a prescribed subject. The Council announce that they have taken over from the Architectural Union Company the lease of the second floor of the premises in 9, Conduit-street, at the rent of £175 per annum, the lease to be coterminous with that of the premises already occupied by the Institute. Two rooms are sublet. Of the remaining three rooms, one will be used, for the present, as an office; another has been fitted with bookcases, to afford storage space for the library, which has outgrown its present accommodation; while the third room, to the front, overlooking Conduit-street, is being fitted up as a tea and smoking-room. The Council have invested since December 31 last £143 in shares in the Architectural Union Company, and £974 11s. 7d. in 2½ per cent. Consols.

#### ARTISTIC COPYRIGHT: PATENT FOR PLANS.

MESSRS. FLOCKTON, GIBBS, AND FLOCKTON, of Sheffield, write in the *Institute Journal*:—In the discussion of the paper by M. Harmond on "Artistic Copyright" [reported in the *BUILDING NEWS* of the 8th inst., pp. 484-5], questions were asked the lecturer as to "whether he was aware that one firm of architects in the country did go so far as to patent one of their designs, and whether he had made any inquiries as to their care in taking out that patent, as to whether it was satisfactory to them, or whether it had any effect in any way upon other architects."

We believe we are the only firm in the country who have patented a design, and that probably, therefore, the questions refer to us; and the Institute having so lately discussed the subject, it may interest readers to hear our replies—viz.: We protected our design as a "plan," not as an "artistic design," and that it has not yet been directly infringed is due either to the care with which the patent was prepared, or to the worthlessness of the subject of it; that the latter is not the case we infer from the fact that nearly the whole of the municipal buildings since designed have partially adopted the separation of departments, that the separation of departments has been wholly adopted in a polytechnic institution, and the building in wings with a central hall and staircase has been adopted in a public hospital. In further reply, the patent has not been satisfactory to us, inasmuch as it has not benefited us, and has, we believe, deterred other architects from adopting the plan in its entirety.

Remembering that at the time of taking out

the patent we were recommended by the Council of the Institute not to do so, but to follow the honourable tradition of the medical profession, we are pleased to find that the kindred subject of "Artistic Copyright" has been thought of sufficient importance to be the subject of a paper read before the Institute.

#### LATER RENAISSANCE ARCHITECTURE IN ENGLAND.\*

[WITH LITHOGRAPHIC ILLUSTRATIONS.]

THE Gothic Revival, at any rate in a general sense, has become a thing of the past; the "Queen Anne" style, so-called, is dead; the ornate confectionery of the resuscitated Renaissance is wearing itself out with attenuated detail, while fashion is turning towards a Later type of work. This movement probably will be aided by the determination of the First Commissioner of Works, who has decided that the new Government buildings in Parliament-street shall be designed in a Classic style. The choice of an architect mainly, in fact, turns upon the conditions thus insisted on. He must be familiar with the principles, not so much it would seem of pure Classic architecture, but of the application of Classic forms as seen in buildings erected subsequently to the Elizabethan period. Moreover he must, to obtain the War Office commission, be able to show by his executed works that he has put this knowledge into practice. We make no objection to the selection of a style, but everything must depend upon the choice of the architect. No matter what the style—indeed it would be wiser to say as little as possible about that—the success of the design depends wholly upon the individual selected to design it. No number of photographs and measured drawings of historic examples, no mere acquaintance with the various archaeological phases of building in any given period, or, for that matter, of all periods, will compensate for the absence of a capacity to design, and a capability to carry through the general design in detail. Books and pictures of buildings are at best very limited in practical value, after all. Sketching, indeed, and measuring up fine examples, will not make an ordinary man into an architect in the true sense of the word. Nevertheless, in spite of all this, books are of the greatest use, and sketching or measuring must form the basis of an architect's knowledge. Photographs as records obviously remain unsurpassed in usefulness, and when the prints are permanent their utility is clearly enhanced, while, if the photographs illustrate the style in vogue, they become necessarily of consequence as patterns for the practitioner. Mr. Batsford aims, no doubt, primarily at a higher and more lasting character for his books; but the production of these folios in illustration of the Later Renaissance, under the joint editorship of Messrs. J. Belcher and Mervyn Macartney, may be considered timely and appropriate even in the transitory sense which we have ventured thus to indicate. For the profession no better recommendation could be mentioned, architects in business must be up to date, and most professionals desire to be *à la mode*. The issue, therefore, of the third part of the "Later Renaissance Architecture in England," to which we have today to direct attention, seems unusually opportune, and we may supplement these remarks by illustrating one of the plates from the folio in question, giving as a specimen the view of the Entrance to Clare College, Cambridge, an exceedingly happy example of 17th-century architecture, marked by a purity of grace in perfect keeping with the destination of the building, essentially modern in idea, and yet quite in good taste. The college was commenced in 1638; but the Civil War hindered the progress of the work, which was renewed after the Restoration, though not completed till 1715. The chapel, which is not a success, was finished in 1769, from the design of Sir James Burrough, then Master of Caius. St. Catherine's Hall, Cambridge, also illustrated in the part before us, was commenced in 1760; but its design retains the mullioned windows of Elizabethan, not to say Gothic character, in a like manner, to some of the windows in Clare College, thus producing a happy combination of features not really at variance, in themselves, and

\* Later Renaissance Architecture in England: a Series of Examples of Domestic Buildings erected subsequent to the Elizabethan Period. Edited by J. BELCHER and MERVYN E. MACARTNEY. London: B. T. Batsford, 94, Holborn. 21s. net.

evolving, as a whole, a complete and characteristic English style.

Messrs. Belcher and Macartney have not hesitated to include in their book several minor 17th and 18th-century houses of ordinary type to be seen in the main streets of some of our older towns, as for instance, the shops and houses at Stamford, Hertford, and Warwick. A few of the more ambitious subjects gain much from their surroundings, and one of these is the mural fountain in the garden at Bowood, Wilts, where the detail is poor. Swatley Hall, Uxbridge, rather overcrowded with gables, is a handsome house, having, however, very ill-proportioned windows. The exquisite detail of Ashburnham House staircase from Westminster, is beautifully rendered, and Mr. Harry Sirt's carefully measured drawings of it much increase the value of the series. Coleshill, Berkshire; Thorpe Hall, Peterborough; Ball's Park, Hertford, and the brick-fronted house at Farnham, Surrey, serve to make the collection representative, though we should hardly admire their repetition in actual execution nowadays. The Earl of Burlington's villa at Chiswick, at present used as a private lunatic asylum, and the stone-built houses in Cavendish-square, are of a higher type of work entirely, while, of course, Greenwich Hospital Chapel, the Senate House, Cambridge, and Hampton Court Palace illustrate the choicest buildings of their periods, each, however, in its individual way. The staircase ceiling from Belton House, Grantham; the Pin Mill, Stroud; the staircase photographed at Eltham, and the measured gateways and portico from Groombridge Place, Kent, show how thoroughly the editors have worked to make their undertaking a success. The old Classic house, from the Close, Salisbury, is among the most suggestive in the folio, and its interior details are useful, too. The same may be equally well said of Mr. J. Joass's drawings of the Senate House, Cambridge, or of Mr. H. P. G. Maule's measured elevations of Hampton Court Palace river front. Mr. Batsford spares neither pains nor enterprise in producing a work worthy of the occasion.

#### CHIPS.

The Midland Railway Company have decided to abandon the clauses of their Bill enabling them to construct a line from Thornhill to Huddersfield and thence to Halifax.

The urban district council of Hove have received sanction from the Local Government Board for the borrowing of £6,500 for works of street improvement. The work is to be done in three sections; £2,000 is to be spent at once.

A large house ("Hazelbank") in the Scores, St. Andrew's, N.B., built for Mr. G. Coutts Douglas, J.P., from plans by Mr. John Milne, is nearing completion. The contractors are:—Mason work, A. and J. Carstairs; joiner, Andrew Cunningham; plasterer, Andrew Scott; painters, M'Gregor and Son; electric fittings, A. Westwood and Son, Dundee.

At Clutton, near Bristol, a curious stained-glass window has been recently inserted in the parish church in memory of the Rev. Albert Boudier, who for eighteen years was rector of the parish. The window represents St. Dominic, the founder of the famous preaching order, in his black and white robes, and St. Basil in the dress of a Greek bishop. The reason for the selection of subjects is that Mr. Boudier was born on St. Dominic's Day, 1823, and died on St. Basil's Day, 1897.

Mr. J. R. Findlay, of Abouler, has further enriched the National Gallery of Scotland by adding to its collection the picture "La Gloria," by the late John Philip, R.A. To Mr. Findlay was due the foundation of the Scottish National Portrait Gallery, he having offered the sum of £10,000, in addition to the cost of the building, towards its establishment, providing a like sum was forthcoming from the Treasury. His offer was accepted and the gallery commenced. He has now given a further £10,000 towards the external and internal decorations. It is announced that Mr. W. Hole, R.S.A., is to have charge of the decoration of the central hall and ambulatory.

Cromford Church, on the banks of the river Derwent, has, during the past year, been undergoing internal alterations. The chancel before the alterations was cut off from the nave by the projecting ribs of the arch, making the church consist almost of two buildings. A new arch has been built, springing from the north and south walls, and the chancel filled with oak stalls. The west end has received new windows. This work has been carried out by Messrs. Naylor and Son, of Derby. The plaster walls of chancel and nave have been decorated by Mr. Alfred O. Hemming, that in the chancel illustrating the early life of Christ.

## OBITUARY.

WE record with regret the death of Mr. WALTER SECKHAM WITHERINGTON, F.R.I.B.A., of Great Tower-street, E.C., after an illness of seven weeks, on April 18, at his residence, Aberdeen-road, Highbury Grange, N., at the age of 56. He was interred at Highgate Cemetery on Thursday in last week. The deceased was the son of Mr. Thomas Witherington, chemist, of Worcester, and he served his articles with the late Mr. Henry Day, of that city. He came to the Metropolis 30 years since, and soon commenced to work on his own account. His practice was a considerable one in the City of London, where he built a large number of offices and warehouses, hotels and licensed houses. Several undertakings associated with the improvement of business premises in London were due to his enterprise and skill as a practical architect. Mr. Witherington had a large connection in arbitrations, and in determining disputes his knowledge and integrity were highly valued and relied on. He was elected a Fellow of the Royal Institute of British Architects in 1881.

MR. WILLIAM KETTLEWELL, of Leeds, died on Wednesday week at his residence in Chapel-town-road in that city, aged 67. He was the son of the late William Kettlewell, founder of a firm of furnisiers and decorators in Park-row, Leeds, and succeeded his father in its management. A year since he retired, and was in turn succeeded by his son. Only on the Friday preceding his death the workpeople presented Mr. Kettlewell with his portrait painted in oils by Mr. Percy M. Teesdale, to mark the completion of his 50 years of business life. For a lengthened period Mr. Kettlewell took an active interest in the affairs of the city. From 1883 to 1890 he was a member of the City Council, and during that period was chairman of the lamp committee and deputy-chairman of the streets and sewerage committee. He was the president of the West Riding Association for the Protection of Trade, and also held the office of treasurer of the Associated Trade Protection Societies of Great Britain.

## CHIPS.

The Forest Brickworks at Tunbridge Wells were formally opened by the Marquis of Abergavenny on Thursday in last week. The undertaking has been started by Mr. W. Barnsley Hughes, a local architect, and covers an area of 20 acres. The works have been planned by Mr. E. P. Lee, of the Cardiff Brickworks, and the machinery has been supplied by Messrs. John Whitehead and Co., of Preston.

A stained-glass window is about to be placed in the Hollness Memorial Church at Wisbaw. The work has been entrusted to the firm of Stephen Adam and Son, Bath-street, Glasgow, who have already filled all the other windows in the church for the Houldsworth family. In the upper panels of the window Nehemiah is depicted as directing the rulers of Israel to repair the broken walls of Jerusalem, while in the lower division of the window is shown the servants of the Centurion entreating Christ to visit his sick servant.

A Primitive Methodist church and schools are being built at Leicester from plans prepared by Mr. Harper of Nottingham. The church will seat 600 persons on the ground area, and 400 in the galleries. The facings are of pressed brick with Hollington stone dressings, and the entire cost will be £3,500. Messrs. Laugton and Son, of Enderby, are the contractors.

A Primitive Methodist chapel and schools are to be erected in Camp-street, Great Clowes-street, Lower Broughton, Manchester. The schools, the stone-laying ceremony in connection with which took place on Saturday afternoon, and the caretaker's house, are already in course of erection, at an estimated cost of £2,600.

The ninth annual exhibition of school drawings, held by the Royal Drawing Society of Great Britain and Ireland, was opened on Monday afternoon by the Hon. Lady White Ridley at 50, Queen Anne's-gate, S.W. Sir Wyke Bayliss, who presided, alluded to the growth of the society, and to the evidence of improvement on the part of the exhibitors which was shown by a comparison of the reproductions of previous years with the works of the same pupils this year. Mr. T. R. Ablett, the hon. director, said the age of exhibitors ranged from four to 20 years, and they were pupils in the great public schools, high schools, and grammar schools. Altogether about 170 schools were represented, some being in Scotland and Jersey, and one in Newfoundland. Lady Ridley, in declaring the exhibition open, expressed thorough approval of Mr. Ablett's system of teaching. The exhibition will remain open until Saturday in next week, May 7.

## Building Intelligence.

BIRMINGHAM.—A new building is about to be erected to house the Birmingham Old Library at the corner of Margaret and Cornwall-streets. Messrs. John Barnsley and Sons are the contractors. The designs, by Messrs. Cossins, Peacock, and Bewlay, provide for a building of two stories, with an extra floor in the roof in the rear portion. The principal frontage, which will be in Margaret-street, will have a length of 8ft., while along Cornwall-street the library will extend 87ft. The architects have adopted the style of the English Renaissance. The Margaret-street front will be broken up into three sections, that at each end being gabled, while the middle section will be slightly recessed, this arrangement leaving a narrow area space for lighting the basement and breaking the line of the façade. The middle section will be divided into three bays by buttresses, surmounted by piers. In each bay on the ground floor will be a four-light mullioned window, with semi-circular head. In the upper story each bay will contain two rectangular two-light mullioned windows. The smaller of the gabled sections will contain two three-light mullioned windows, and the larger, that next the corner, a large five-light window on the first floor, with the principal entrance beneath. The Cornwall-street frontage will be treated in a similar way. Each of the projecting portions of the frontage will be faced up to the first floor with white Hollington stone. The remainder of each façade will be made up of bright-red Ruabon facing bricks, with bands of white Hollington stone, the latter also being used for the other ornamental features. The entrance portico and lobby will be faced with stone. Swing doors will give access to a hall, 23ft. by 27ft., in communication with the clerk's office and the librarian's room and a committee-room. Adjoining the hall will be the lending-library, a hall 54ft. by 35ft. This will contain adjustable shelving for 25,000 volumes. The shelving will be on iron frames, arranged in bays, and the floors here, as throughout the building, will be fireproof. The library will be laid with wood blocks, and the entrance hall with mosaic pavement. A stone staircase will lead to the upper floors. The principal room on the first floor will be the general reading-room, which will have a ceiling of segmental section divided into bays by the wooden roof principals. Adjoining the reading-room will be a small room for rare books, a smoking-room 32ft. by 23ft., and a lady proprietors' room. The second floor will be devoted entirely to the storage of books. The basement will contain the books not in current demand, a book-repairing room, an assistants' mess-room, the caretaker's rooms, the heating-chamber, and the coal-store. With the shelving placed on the walls of most of the rooms, the library, which at present owns 80,000 volumes, will have room for about 200,000.

CHESTER.—The memorial-stone of a Primitive Methodist chapel was laid in Hunter-street on April 20. The style adopted is a free treatment of the 15th-century English Gothic. Red Ruabon bricks are to be used in the facings, the finishing of the doors, windows, gables, and tower consisting of a golden buff terracotta. The constructive timber employed will be Baltic redwood, stained and varnished pitch-pine being selected for the internal joinery. Covering the building will be a roof of Welsh purple slates. Tinted rolled cathedral glass in lead-lights has been chosen for the windows. The tower will be utilised as a foul air extractor. The site of the building is 51ft. by 56ft., almost a square; the ground plan of the church portion is in the form of a Greek cross, the corners being devoted to entrances, vestries, &c. Ministers and stewards will be provided for on the ground floor, while two vestries will be arranged on the gallery floor. The heating apparatus will be located in the basement. The total sitting accommodation is for 570, and the vestries afford accommodation for 56 more. The chapel was designed by Mr. Thos. Howdill and Mr. Chas. B. Howdill, A.R.I.B.A., of Leeds, while the whole of the building contract has been let to Mr. Wm. Vernon, of Chester.

CONISTON.—The new institute was opened on Tuesday evening in last week by Mrs. Arthur Severn. The original roof now covers a reading-room, recreation-room, smoke-room, committee-room and small museum. The additions, which

have cost over £2,000, comprise a caretaker's cottage, with refreshment-bar and a bathroom, and a large assembly-hall. The latter room will accommodate upwards of 500 persons. There are three ante-rooms in connection with it. The whole building, with the exception of the cottage, is heated by hot water. The plans were prepared by Mr. R. Walker, of Windermere. The contractors were:—Mr. George Usher for walling, Messrs. J. and J. Bell for joiners work, Messrs. Redhead for painting, plumbing, and glazing; Mr. H. B. Armstrong, Windermere, for plastering; and Messrs. Seward and Co., Lancaster, for heating.

CREWE.—The Earl of Crewe laid, last week, the foundation-stone of a new chancel, which is being added to Christ Church, Crewe. Mr. John Brooke, of Manchester, is the architect, and Mr. Matthews, of Nantwich, the builder. The complete scheme provides, in addition to a chancel, for a morning-chapel on the north side, and clergy and choir vestries and an organ-chamber on the south side, but the present contract includes only for the building of the chancel. Following the method so often found in connection with Mediæval churches, the new chancel is designed in a different style to that of the existing church, the style adopted being Perpendicular and treated with modern detail. The internal dimensions of the chancel will be 36ft. long by 20ft. wide. The east window will have five lights, the sill being raised high above the chancel floor. In each of the side walls there will also be windows of two lights forming a clerestory. On the north side there will be a double arcade, which will eventually open into the morning-chapel, also a credence in conjunction with a squint window from the future side-chapel. The present chancel arch will be replaced by an arch of more lofty proportions, and the roof of the new chancel will have hammer-beam principals, and a boarded and panelled ceiling. The walls will be of brick, with grenstall stone dressings to the windows, doorways, arches, and string-courses. The upper part of the inside walls will be finished in cement plaster with a granulated face, the lower parts of the walls being faced with specially-made Ruabon bricks. The roof will be covered with grey Westmoreland slates upon boarding and roofing felt. The floor of the chancel and sanctuary will be paved with tiles, excepting the space occupied by the choir-stalls, which will be paved with wood blocks.

The London Tramways Company appealed to the House of Lords on Monday to reconsider a previous decision as to the principle on which the County Council was to give compensation to tramway companies for the compulsory acquisition of their undertakings. The Lord Chancellor, however, said he adhered to the opinion expressed by eminent authorities in that House that a decision once given by the House on a point of law was conclusive ever afterwards, and it was impossible to raise the same question again. The other law Lords concurred, and the appeal was accordingly dismissed.

The new church of St. Edward, Birmingham, will be dedicated by the Bishop of Coventry to-morrow (Saturday). A year ago the buildings in New John-street West, on the west side of Summer-lane, consisting of a large chapel and schools, which had been occupied by the Presbyterian body, were bought and presented to the Church of England. Besides structural changes, an altar, pulpit, choir-stalls, organ, and vestries were required. The architectural work has been carried out under the direction of Mr. H. T. Buckland, who has transformed what was formerly a plain chapel into a well-fitted church.

A two-light window has been fixed at the east end of the south aisle of Christ Church, Ebbw Vale, Mon., the subjects treated being the "Resurrection" and "Our Lord as the Good Shepherd." The work was entrusted to Jones and Willis, of Birmingham and London.

The ancient churchyard cross at Elmswell, Suffolk, has just been restored at the cost of Mrs. Luke, in memory of her late husband, Dr. Luke, sometime rector of the parish. The cross is over 17ft. high. The shrine contains a Calvary, and is surmounted by a floriated cross. The old base is a remarkable and beautifully ornamented piece of work, and the lower portion of the shaft was rescued by the present rector from the grounds of a house in the immediate neighbourhood.

The Lord Mayor and the Sheriffs will on Wednesday, June 1, pay a State visit to Margate, to formally open a piece of land, about 33 acres in extent, which Mr. John Woodward has recently presented to the town for the purpose of a public park and recreation ground, with the necessary approaches and roads.

CONTENTS.

Architecture at the Royal Academy.—I. ....	587
Pictures at the Royal Academy.—I. ....	587
The New Gallery .....	589
Model Specifications.—X. ....	589
The Society of Architects' Dinner .....	591
The Architectural Association .....	592
The R.I.B.A. Council Report .....	596
Artistic Copyright: Patent for Plans .....	597
Later Renaissance Architecture in England.....	597
Obituary .....	598
Building Intelligence .....	598
THE BUILDING NEWS DIRECTORY .....	IX.
Our Illustrations .....	599
Parliamentary Notes .....	599
Professional and Trade Societies .....	619
Correspondence .....	619
Intercommunication .....	619
Legal Intelligence .....	620
Water Supply and Sanitary Matters .....	621
Our Office Table .....	621
Meetings for the Ensuing Week .....	622
Trade News .....	622
List of Competitions Open .....	623
List of Tenders Open .....	623
Stained Glass .....	624
Tenders .....	625
Latest Prices .....	626

ILLUSTRATIONS.

- CROWN THEATRE, PECKHAM.—CLARE COLLEGE, CAMBRIDGE.
- HALL, GOODRICH COURT.—TECHNICAL SCHOOL, COLNE.
- URBAN DISTRICT COUNCIL OFFICES, EAST LEIGH.—
- NEW DINING HALL, BARTON COURT HOTEL.—PALACE OF
- COUNT KOTTULINSKY IN GRAZ.

Our Illustrations.

THE CROWN THEATRE, PECKHAM.

The building, of which Mr. Ernest Runtz is the architect, is now in course of erection in the Peckham-road, Camberwell, on a fine site. We have received no particulars of the undertaking beyond that which can be obtained from the accompanying illustration.

LATER RENAISSANCE ARCHITECTURE IN ENGLAND: ENTRANCE TO CLARE COLLEGE, CAMBRIDGE.

(See review on page 597.)

"THE HALL," GOODRICH COURT.

The hall forms part of large additions made to Goodrich Court a few years ago, for Mr. H. C. Moffatt. It is built of Hollington and Wilderness stones, with large buttresses. The roof is of oak, carefully selected by the owner from the neighbourhood and elsewhere; the scantlings are big, the principals being 26ft. long and 13in. by 10in., the collar and hammer beams 15in. by 10in., and the curved timbers under the hammer-beams are each in one piece. The whole is covered with lead, and there is a lantern on the ridge. The internal dimensions are 70ft. 6in. by 32ft. 6in., and the height 53ft. The organ is a fine instrument, by Willis. The builders are Messrs. Collins and Godfrey, of Tewkesbury; and the architects Messrs. H. A. Prothero and G. H. Phillott. The drawing is by Mr. H. W. Brewer.

COLNE TECHNICAL SCHOOL LIBRARY AND PUBLIC HALL.

THIS design was chosen last December, in an "open" competition, for the first place by Mr. S. W. Beaumont, F.R.I.B.A., Manchester, the assessor appointed by the corporation. The building will be simple in character and detail, stone faced, and is estimated to cost about £10,000. Messrs. Woodhouse and Willoughby, of Manchester, are the architects, the working drawings for which are now being prepared.

EASTLEIGH URBAN DISTRICT COUNCIL OFFICES.

THIS design was submitted in the recent competition by Messrs. Hall, Cooper, and Davis. Accommodation was provided for rate-collector's office, council clerk's public and private offices, surveyor's public and private offices, and plan-room and medical officer's offices on the ground floor. On the first floor are the council-chamber, committee-room, councillors' cloak-room, with lavatories, &c., adjoining, and caretaker's living apartments. The fire-station is planned in a quadrangle adjoining the main building along the Ramsey-road, with stabling accommodation and cart-sheds for the council's working staff. The corn-store, hay-chambers, &c., are planned over the stable. The materials proposed to be used are red bricks, with Bath stone dressings, wood cornices to eaves, and red Ruabon tiles to roofs. All mouldings and other

finishings are to be of a simple character. Internally, the floors of the entrance-hall and landing to be of wood blocks. The vestibules and lavatories of tiles, the council-chamber and other rooms best 1½in. St. Petersburg flooring in narrow widths. The council-chamber to have a dado of wood panelling, the main stairs to be York stone.

ADDITIONS TO BARTON COURT HOTEL, BARTON-ON-SEA, HANTS.

THE new wing to this hotel, which is now in course of erection, will contain a large new entrance hall and lounge, dining-hall (capable of seating over 100 guests), extra suites of private rooms, kitchen, servants' hall and offices, and upwards of 30 new bedrooms. The dining-hall, of which we publish an interior perspective, will have large mullioned and transomed windows commanding uninterrupted views of the Needles and the Isle of Wight on the east. The western side has a fine outlook over Bournemouth Bay to Swanage, and the large bay window facing south looks directly on the English Channel. Each of these windows gives access to the lawns which extend to the cliffs and the easy approaches to the beach. The works will be completed during the present summer season. The architects are Messrs. Dancaster and Rogerson, of Bournemouth and London.

PALACE OF COUNT KOTTULINSKY IN GRAZ.

THIS handsome staircase executed in marbles has been designed by M. L. Gunold, the architect, whose work is enriched by gilding and colours freely introduced, producing a rich and dignified effect. We have no other particulars of the undertaking.

CHIPS.

Mr. John Weekes, the oldest resident of Dodbrooke, Plymouth, died on Thursday in last week, in his 92nd year. Deceased for many years carried on a successful building business, and had long retired.

The centre lights of the large eastern window of the chancel aisle in the parish church of Spaxton have just been filled with rich stained glass, the subject being Christ before the Doctors in the Temple.

The dedication of a stained-glass window in memory of the late Sir T. Percival Heywood took place in the church of St. John the Evangelist, Miles Platting, Manchester, on Saturday afternoon.

The Plans Committee of Aberdeen Town Council had before them on Friday plans of thirteen new erections. The value of the buildings is estimated at £27,000. One of the buildings is a new school in Hanover-street to cost £10,000.

A Joint Committee of Parliament which has been appointed to inquire into the various schemes for the supply of electricity which are now before the public, and to frame suggestions for the guidance of the companies, held its first sitting on Friday.

The school board for Rochester have adopted plans by Mr. G. E. Bond, M.S.A., of that city, for new schools in Gordon-road, estimated to cost £5,000.

At Penzance, on Friday, a block of new Church day-schools, erected close to the Western Promenade, was dedicated by the Bishop of Truro, and opened by Lord Cross. The schools accommodate about 630 children. There are three wings, the central hall, which will form the assembly-hall, and two classrooms, the eastern comprising four girls' classrooms, cloak-rooms, and other offices, and the western wing, where accommodation is provided for the boys. At the rear are playgrounds. A feature of the central floor is that it is laid with wood blocks. The elevations are of granite dressings, with Castle-an-Dinas stone fillings. The contract was about £3,300, and the building was designed by Mr. Oliver Caldwell, F.R.I.B.A.

The village of Bickenhill was *en fête* on Friday, on the occasion of the commemoration of the restoration of the tower arch of the parish church, the rehanging of the bells (after a lapse of over twenty years), the dedication of a stained-glass window, and the consecration of a new churchyard by the Bishop of Worcester. The tower of the church was struck by lightning in 1876, and when it was restored ten years later it was found impossible to raise sufficient funds to replace the five bells. Now, however, the difficulty has been overcome.

The new Victoria Sunday-schools, erected in connection with the Tabernacle Chapel, Old Hill, Staffs, was opened on Monday. The schools have been erected by Mr. H. Dorset and Son, of Cradley Heath, from designs by Mr. A. Ramsell, architect, of Dudley, at a cost of £2,000.

PARLIAMENTARY NOTES.

SOUTH KENSINGTON MUSEUM.—Sir S. Montagu asked the First Commissioner of Works on Friday whether, on the enlargement of South Kensington Museum, he intended that laboratories should be placed under the same roof as the works of art; and whether he had ascertained that no damage to pictures and silver could result from the generation of gases and other noxious fumes. Mr. Akers-Douglas: No, sir; it is not intended to place any laboratories under the same roof as the objects of art at South Kensington, so that I do not see how any damage can be occasioned to the works of art. As I have already announced, the allocation of the space in the new building is now being considered by a departmental committee.—On Monday night Sir C. Dilke further inquired of the First Commissioner of Works what portion of the new buildings at South Kensington under the Public Buildings Expenses Act was to be devoted to the housing of the art collections, and what portion to services connected with science; whether the space given to art was to be tenched on by the importation into the art part of some science collections at present housed on the western side of Exhibition-road, and to what extent; whether it was computed by the Lords of the Council that the space assigned to art would suffice for the due exhibition of the magnificent collections at present in the South Kensington Museum; and whether the Lord President of the Council had consulted on the proposed distribution of the new available space the Art Committee of Referees. Mr. Akers-Douglas: It is impossible at the present stage to reply to the right hon. gentleman's question categorically. An Inter-Departmental Committee, appointed by the Lord President of the Council and myself, are now engaged in considering the details of the appropriation of the site to the east of Exhibition-road, and that committee have called upon the architect, Mr. Aston Webb, whose design was approved in 1892, to prepare a modified plan showing how the art collection can be housed, subject to the condition that the Royal College of Science, already placed upon the east side of the road, shall be so enlarged as to accommodate other services connected with science, which have been specified by the Lords of the Council. When the new plans have been prepared, I shall be in a position to reply to the right hon. gentleman's question, and I will give him due notice.

The restoration of Bradford parish church was agreed to at the annual vestry meeting held on Monday. The Bolling Chapel, in connection with the edifice, is to be included in the restoration. There is to be a second holy table for week-day communions, a screen erected in front of the Bolling Chapel, and a screen in front of the chancel. As the Church Congress is to meet at Bradford this year, the work of the church restoration is to be expedited.

At a recent sale at Christie's the main portion of the collection of the late Mr. J. Grant Morris, of Allerton Priory, Liverpool, and 36, Grosvenor-place, London, was knocked down to various buyers for an aggregate sum of £22,000. The prices of works by modern artists showed a marked falling off.

At the parish church of Bledlow, South Bucks, an east window, altar, chancel screen, and litany desk, forming a memorial to the late Miss Mary Greenside, have been dedicated. The east window is filled with stained glass of Early Renaissance character representing the Ascension, and has been executed by Messrs. Ernest Suffing and Co., of Maida Vale, W. The screen is Early English in character, and, together with the altar and litany desk, was carried out by Messrs. Harry Hems and Sons, of Exeter.

An appeal has been issued by the corporation of the Church House, Westminster, for funds with which to carry out the erection of the second section of the building. The chief room will be the permanent meeting-place of the House of Laymen. In addition to this, the west side will also contain nineteen rooms, to be used for letting as offices to church societies. The cost of the erection of this west side is estimated at £18,000, towards which sum £7,100 has already been subscribed.

On Monday afternoon the Bishop of Southwell consecrated St. Augustine's Church, erected in New Normanton, a growing suburb of Derby. The whole of the building has not been completed, but the total cost will be £5,000.

Lord Morley's Committee of the House of Lords passed on Tuesday the City and South London Railway Bill, which confers power upon that company to acquire further lands and construct sidings upon their authorised extensions. The Bill also empowers the company to raise £133,000 additional share and loan capital. The powers originally sought to sell a portion of their undertaking to the City and Brixton Railway Company were struck out of the Bill in its passage through the House of Commons.

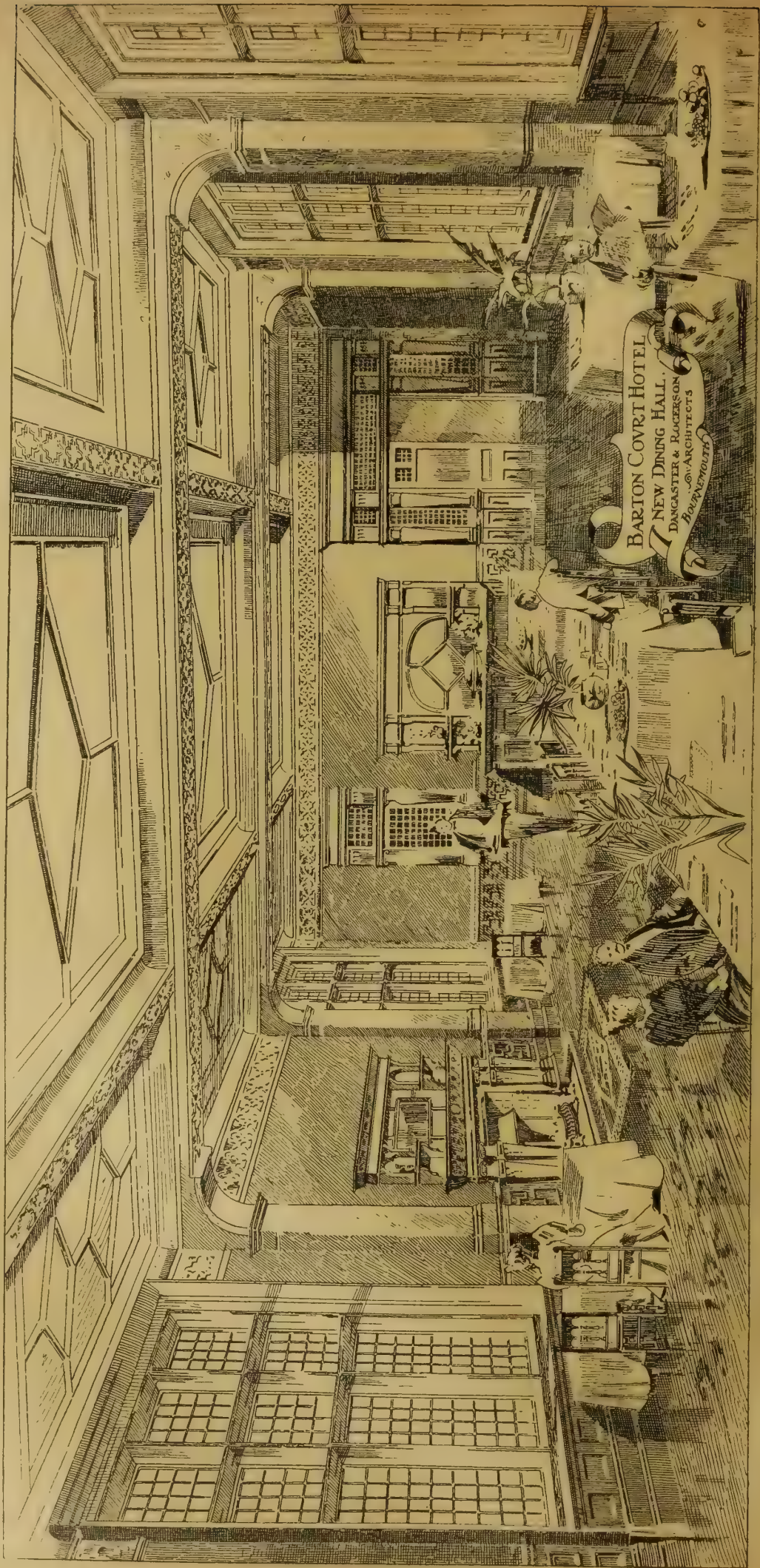





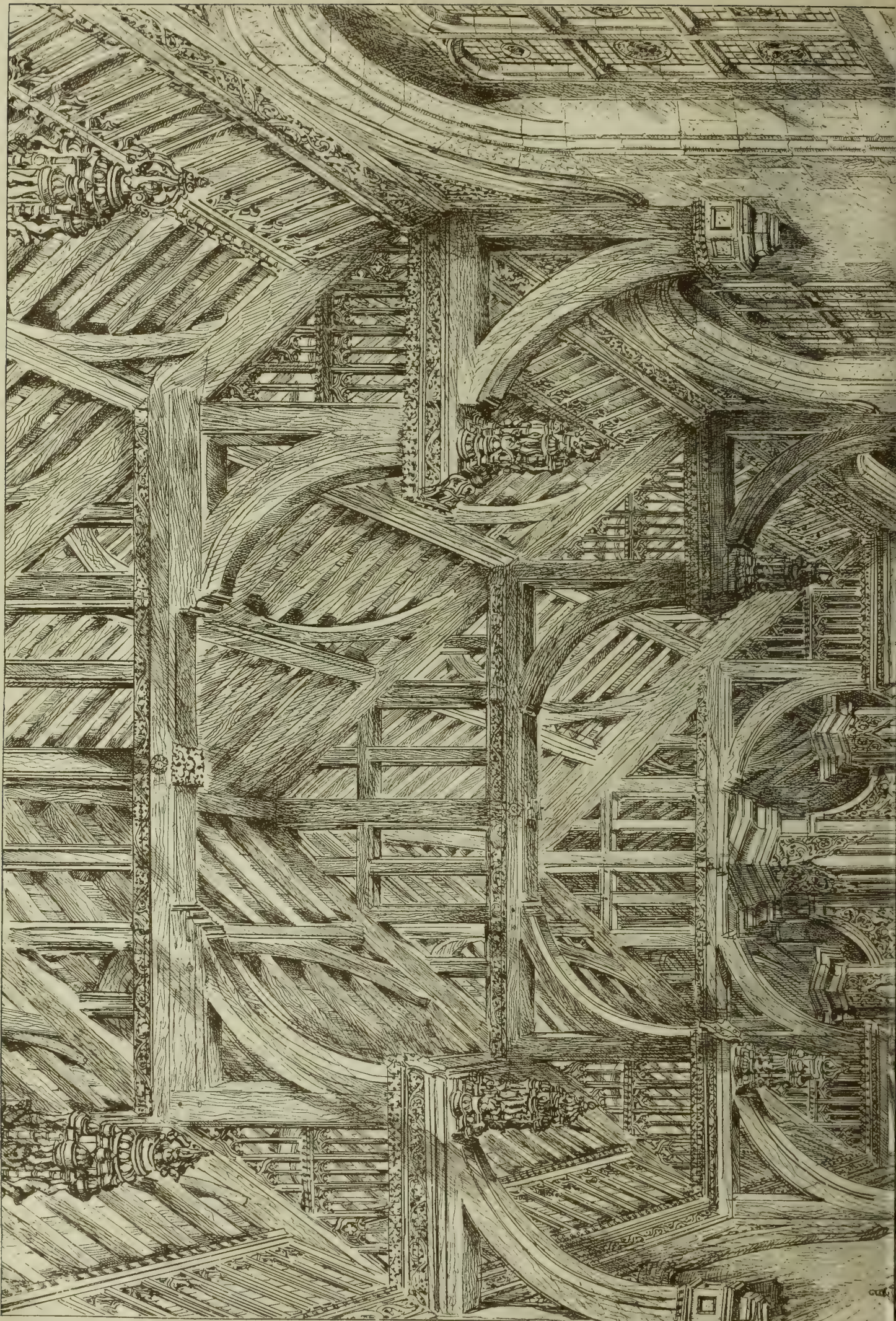

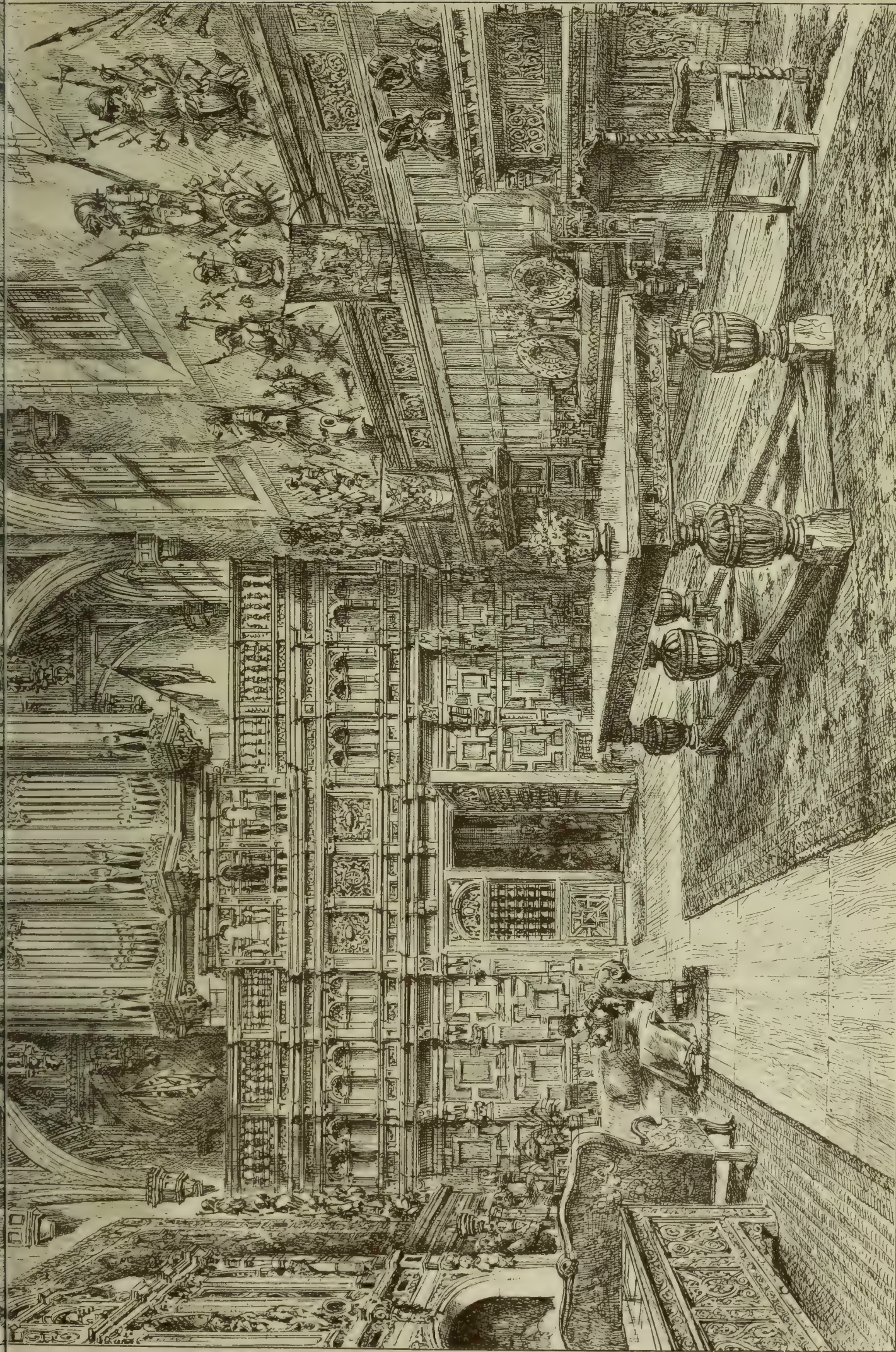





# THE CROWN THEATRE, PECKHAM, S.E.

ERNEST RUNTZ, ARCHITECT.



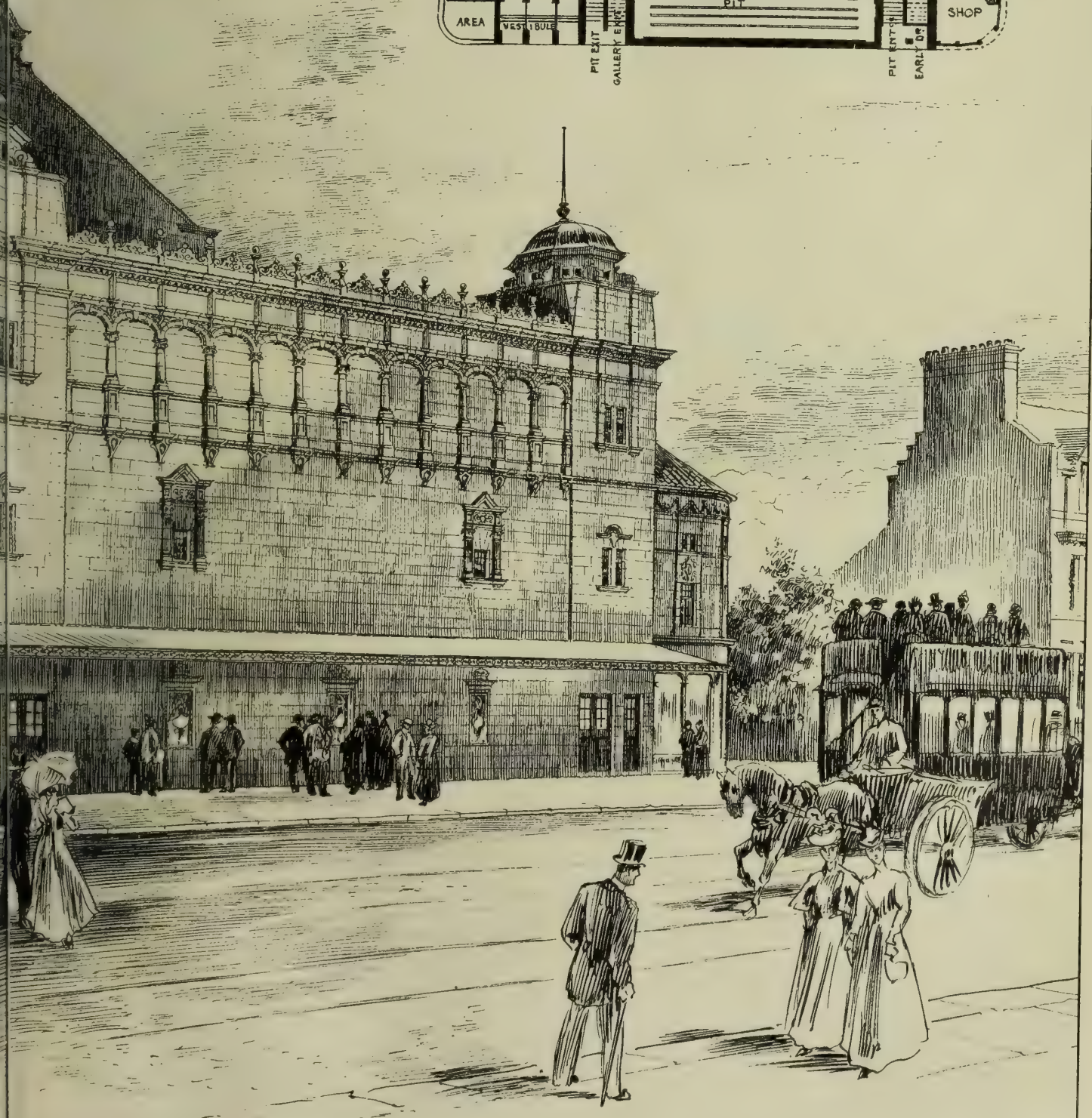
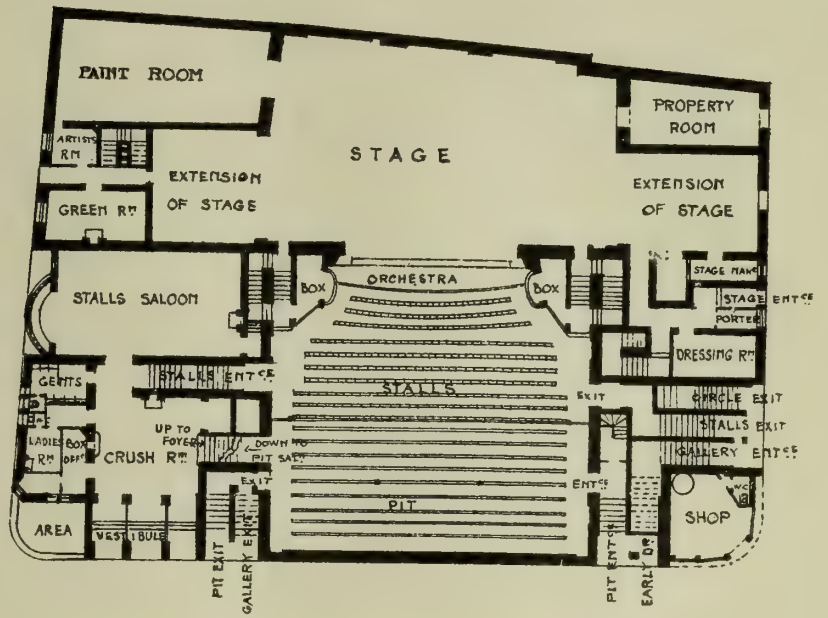







THE BUILDING DEWS, APRIL 29, 1898.

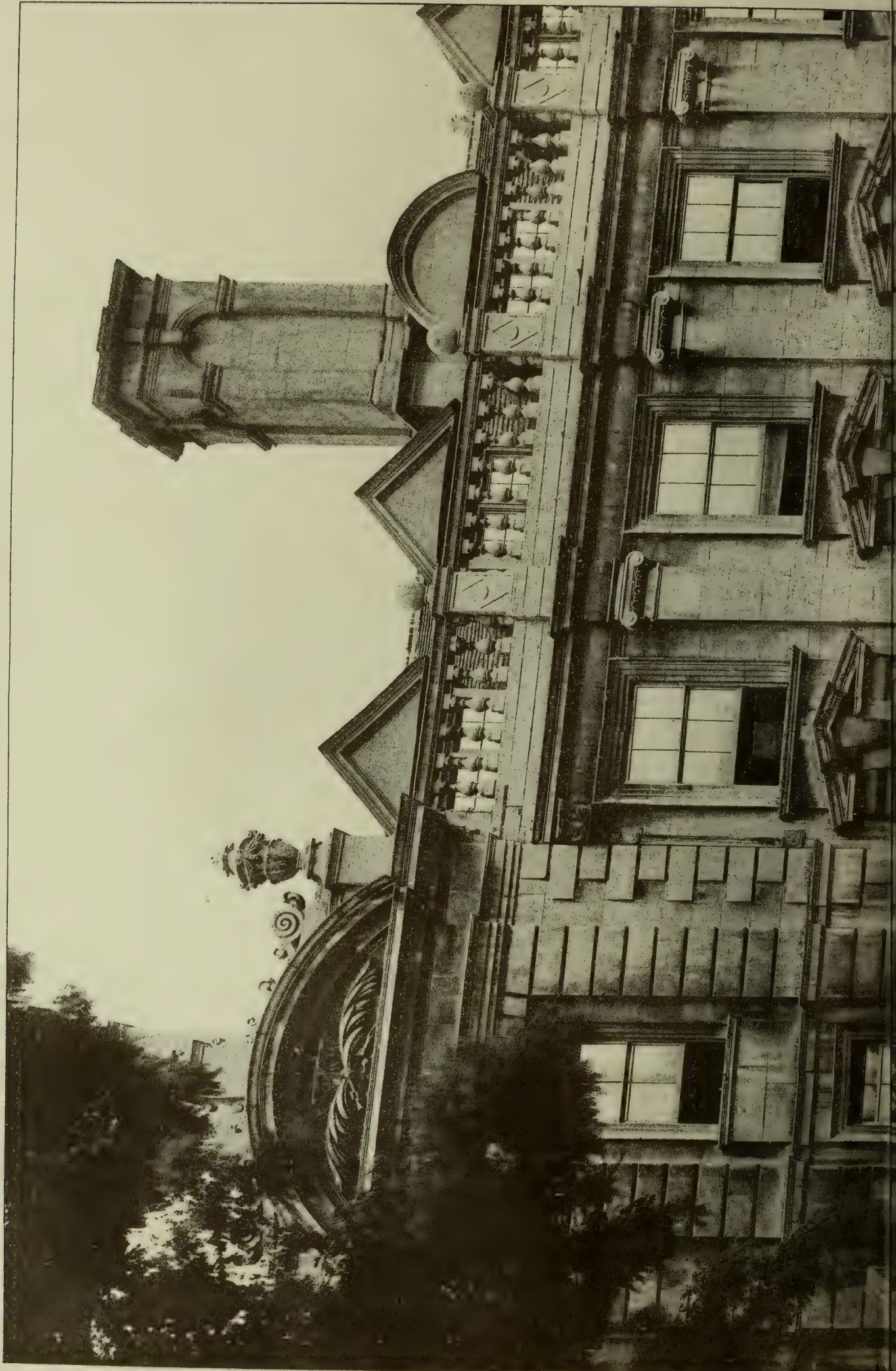

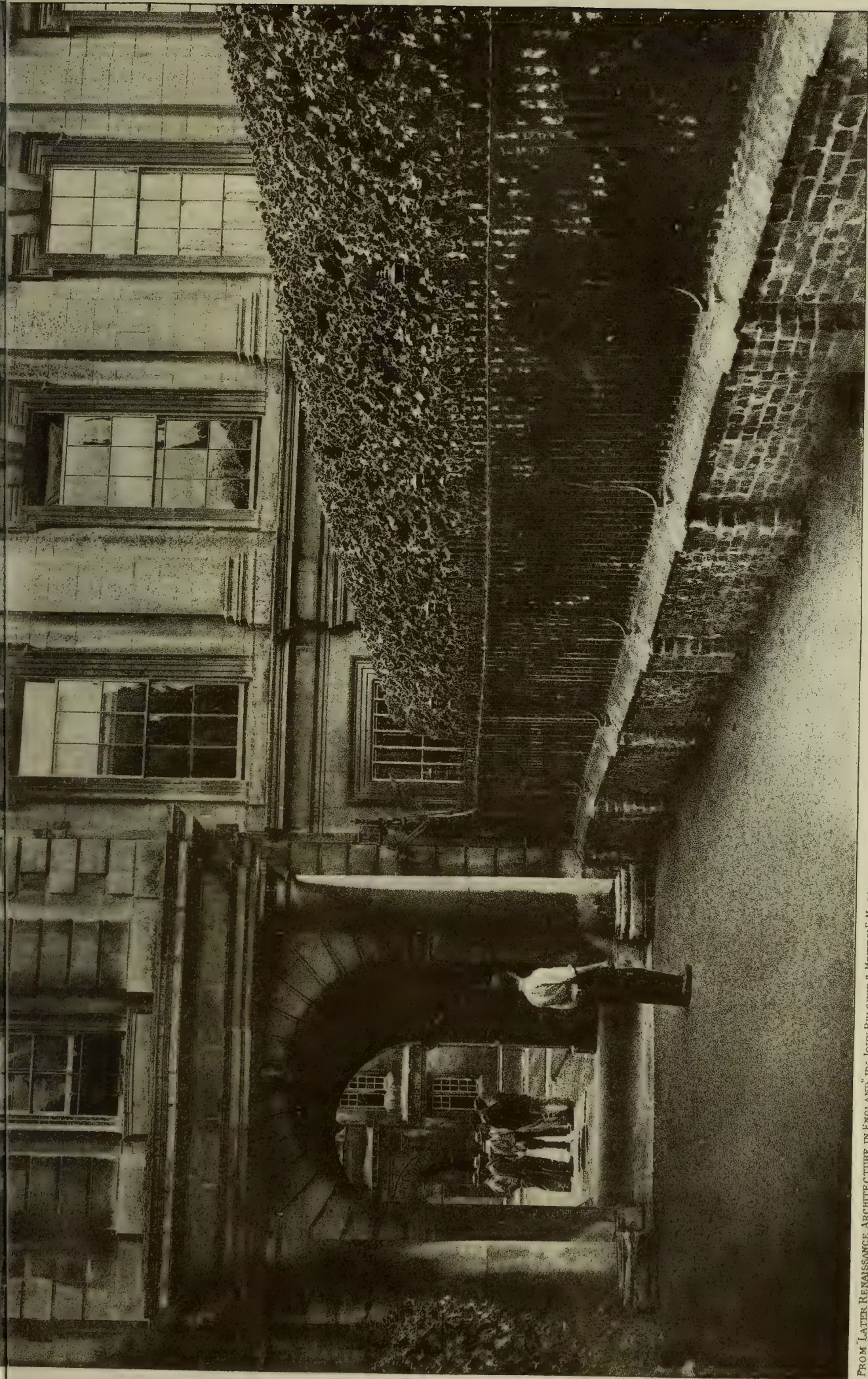

FROM "LATER RENAISSANCE ARCHITECTURE IN ENGLAND," BY JOHN BELCHER & MERVYNÉ MACARTNEY.

"PHOTO-TYPY," BY JAMES AKERMAN. 6, QUEEN SQUARE, LONDON, W.C.

## CLARE COLLEGE, CAMBRIDGE





# COLNE TECHNICAL SCHOOL FREE LIBRARY AND PUBLIC HALL

- REFERENCE
- A TEACHERS' COMMON ROOM
  - B STUDENTS
  - C C STORES
  - D CLEAN ROOM (STAFF)
  - E BALANCE ROOM
  - F PREPARATION ROOM
  - G COMMITTEE ROOM
  - H SECRETARY
  - I ROOF OVER WEAVING YARD
  - J LIBRARIAN
  - K BORROWERS' STAGE
  - L ORIGINALS
  - M RETIRING ROOM (Gent's)
  - N " " (Ladies)
  - O VESTIBULE
  - P TICKET OFFICE
  - Q CLEAN ROOM
  - R R STAIR TO ARTISTS' ROOM (under gallery)

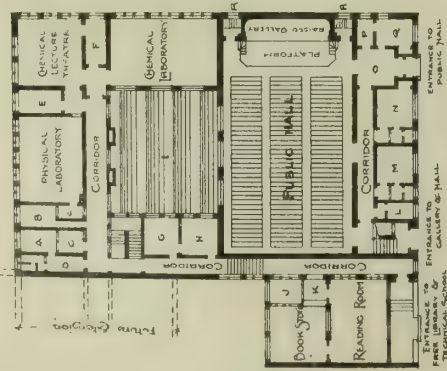

GROUND PLAN.



THE BUILDING NEWS, APRIL 29, 1898.

EAST LETCH. URBAN DISTRICT.  
COUNCIL OFFICES  
MR. COPPELAND DENIS  
ARCHITECTS  
SCARBOROUGH AND WESTMINSTER

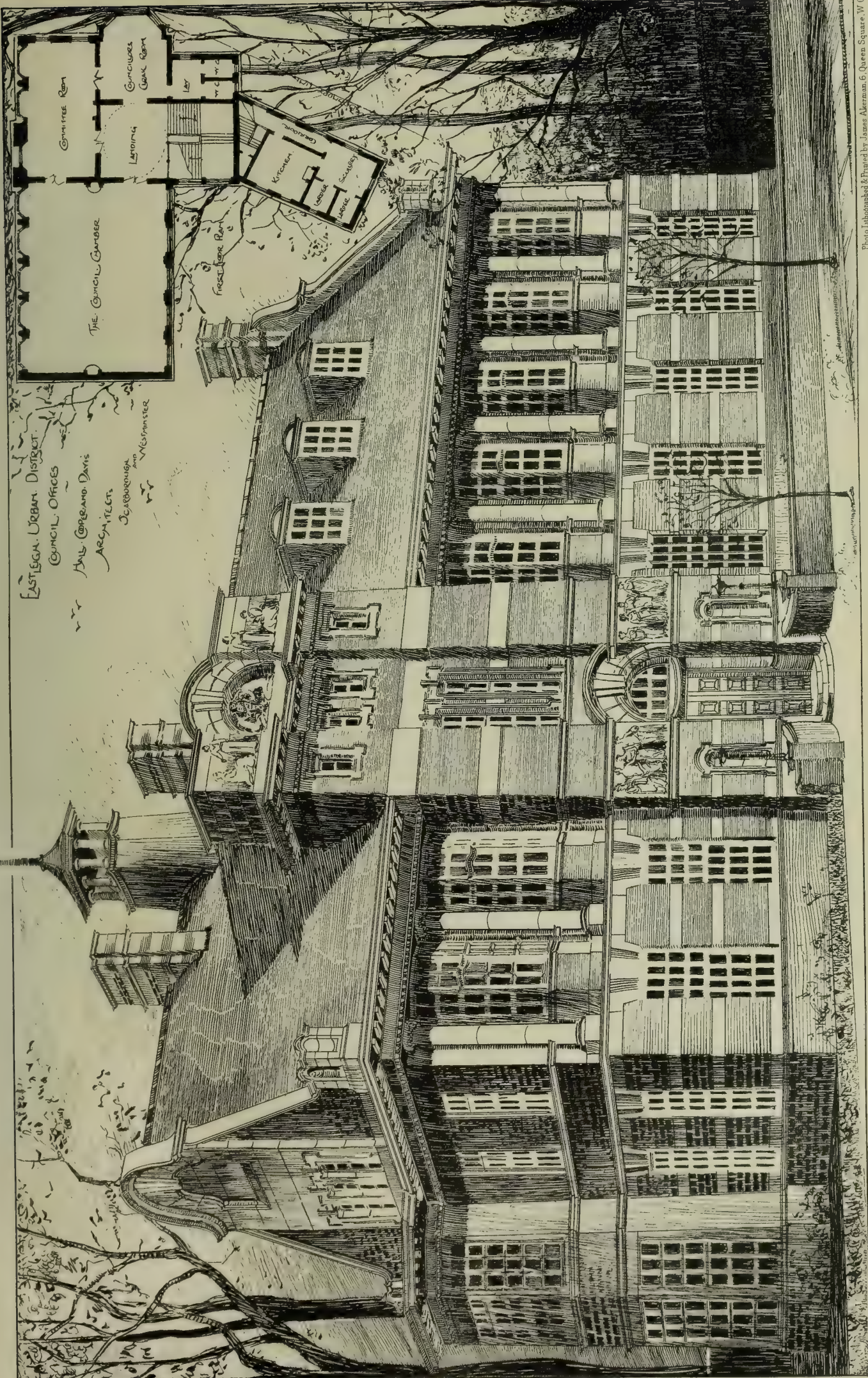







PALACE OF  
COUNT  
KOTTULINSKY  
IN GRAZ.  
L. GUNOLD ARCHT.

### PROFESSIONAL AND TRADE SOCIETIES.

**BRISTOL SOCIETY OF ARCHITECTS.**—The annual general meeting of this society was held at the Fine Arts Academy, Queen's-road, on Tuesday, Mr. F. W. Wills in the chair. The president, Mr. W. L. Bernard, F.R.I.B.A., and vice-presidents, Messrs. Joseph Wood and W. V. Gough, were re-elected, and a vote of thanks was accorded to the retiring hon. secretary, Mr. W. S. Skinner. Mr. H. Dare Bryan was elected hon. secretary for the ensuing season.

**COVENTRY AND DISTRICT BUILDERS' ASSOCIATION.**—A dinner in connection with this Association took place at the Queen's Hotel, Coventry, on Tuesday week. There were present Councillor Haywood (who presided), Mr. J. Worwood (vice-chairman), Messrs. J. E. Swindlehurst (city engineer), E. K. Purnell, W. Hattrell, Harrison, C. Garlick, jun., G. E. Jenkins, Bindley, Bowen (Birmingham Builders' Association), Foster, T. Checkland, T. G. Golby, G. Blakeman, J. H. Cox, G. Storer, H. G. Storer, W. O. Ivens, T. W. Liggins, H. Whiteman, W. Harper, J. Wetton, Grant, Sutton, W. Everitt, Kelly, Isaac, A. Cave, F. R. Carter, C. H. Barber, H. Taylor, C. Watts, J. W. Hogg, &c. The vice-chairman, in proposing the toast of the "City Authorities," referred to the interpretation of the by-laws of the corporation and the borough surveyors. The builders, he said, had hitherto worked harmoniously with the city council, and they hoped in the future to work with equal harmony. The Builders' Association did not want to throw the slightest obstacle in the carrying out of the corporation's object to insure the health and long life of those who occupied houses. The chairman, in replying to the toast, said the by-laws devised five or six years ago were being carried out by a newly-appointed borough surveyor, and some of the builders thought that he had put a wrong construction upon them, but he had no doubt that in the course of a few months everything would be amicably arranged. The surveyor's report on the builder's memorial was under the consideration of a sub-committee. Alderman Bowen proposed the toast of "The Coventry and District Building Trades' Federation." W. O. Ivens and Mr. Harper responded. Mr. T. G. Golby gave the toast of the "Architects, Surveyors, and Engineers." The borough engineer, Mr. Swindlehurst, who was cordially received, in reply to the toast, said a public officer who liked to close his eyes and see nothing might have a nice, quiet, comfortable berth. If he did his duty, his position must be one of unimpeachable integrity all along the line. The by-laws were perfectly plain, and had been in use in Coventry for a number of years. If they were not equitable, then the proper thing to do was to get them amended in such a way as to make them proper by-laws. But as long as they stood there could be but one interpretation put upon them. During the evening a presentation was made to Mr. Garlick, jun., in acknowledgment of his services as hon. sec.

**INSTITUTION OF CIVIL ENGINEERS.**—At the general meeting of the Institution of Civil Engineers, held on Tuesday, Sir John Wolfe Barry, president, in the chair, the result of the ballot for the election of officers was declared as follows:—President, Mr. W. H. Preece, C.B.; vice-presidents, Sir Douglas Fox, Mr. James Mansergh, Sir William Anderson, and Sir William White; other members of council, Mr. James Barton (Dundalk), Mr. Horace Bell, Sir Alexander Binnie, Mr. Thomas Forster Brown (Cardiff), Mr. Henry Deane (Sydney), Mr. W. R. Galbraith, Mr. George Graham (Glasgow), Mr. J. C. Hawkshaw, Mr. Charles Hawksley, Mr. G. H. Hill (Manchester), Dr. Hopkinson, Mr. J. C. Inglis, Mr. Alexander Izat (India), Dr. Alex. B. W. Kennedy, Mr. John Kennedy (Montreal), Sir James Kitson, M.P. (Leeds), Mr. A. G. Lyster (Liverpool), Mr. William Matthews, Sir Guilford Molesworth, Sir Andrew Noble (Newcastle-on-Tyne), Mr. Alexander Siemens, Mr. Thomas Stewart (Cape Town), Mr. F. W. Webb (Crewes), and Sir Leaper Williams (Manchester).

**NEWCASTLE, GATESHEAD, AND TYNE MASTER BUILDERS' ASSOCIATION.**—At the annual meeting of this Association, held on Tuesday, Mr. Walter Lowry was unanimously re-elected President for the ensuing year. In his opening address, Mr. Lowry remarked that during last year the Association had held a large number of meetings owing to disputes with some of the trades, but

taking the year's working on the whole, it might be considered very satisfactory. One matter of very great importance to the building trade had been accomplished. He referred to the formation of the Northern Counties Federation of Building Trade Employers, the first general meeting of which would be held in a fortnight, when the Federation would be in working order. Great success had attended its formation, as the whole of the Master Builders' Associations in Northumberland, Durham, Westmoreland, and Cumberland (with the exception of one with whom negotiations were pending) had consented to join. Federations of a similar nature were being formed in most of the other counties in England, with the intention eventually of all joining together and forming a National Federation of the Building Trade Employers of England. He wished it to be clearly understood that the objects of this Federation were conciliatory to the operatives, and that it would in all cases of dispute with them, do its utmost, by arbitration or otherwise, to avoid strikes and lock-outs. After the election of officers, the notices for advances in wages received from the Operative Stonemasons' and the Carpenters' and Joiners' Societies were considered. In both cases, after considerable discussion, it was decided to make a counter-offer of  $\frac{3}{4}$ d. per hour advance from 9d. to 9 $\frac{3}{4}$ d. in place of the 1d. requested; the offer to the stonemasons to be subject to their reverting to the nine-hours day.

**SCOTTISH BUILDING TRADES FEDERATION.**—The half-yearly meeting of this Federation was held on Friday afternoon in the Palace Hotel, Aberdeen, Mr. John B. Hay, builder, Dundee, president, in the chair. Representatives were present from all parts of the country, including Glasgow, Edinburgh, Dundee, Aberdeen, Inverness, Oban, Hawick, Perth, and Dunfermline. The secretary, Mr. James L. Selkirk, C.A., Glasgow, submitted his report regarding the progress and consolidation of the Federation throughout the country, from which it appeared that additional branches had been formed in most of the towns and districts which had not already been organised. Arrangements are in progress for overtaking other places not yet dealt with. The interest in the work of the Federation was manifestly deepening in all parts of the country, and would be further exhibited as the advantages of federation came to be more fully realised. Various matters were discussed by the meeting, and among the principal were the Workmen's Compensation Act, and the question of insurance arising out of it. A committee was appointed to ascertain the most advantageous terms on which insurance could be effected, and to recommend accordingly.

**SHEFFIELD SOCIETY OF ARCHITECTS AND SURVEYORS.**—The eleventh annual report of the council of this society, presented at the meeting held on Tuesday night, states that the society is in all respects in a better position than at any previous period of its history. Financially, the balance in hand is the highest that has ever been reported, and this notwithstanding that there has been a special course of class lectures during the present year. The council recommend that the balance at present in hand, £121 18s. 7d., be invested as a reserve fund. Numerically, the society has continued to grow, and although there have been two deaths, two withdrawals, and three lapses of membership during the year, there has been a net increase of eight in the number of members. There are now 114 members, consisting of 31 fellows, 43 associates, 18 students, 5 honorary, and 17 lay members. The council refer with regret to the deaths of Mr. T. H. Wilson, who had been a fellow from the formation of the society, and of Mr. B. D. Wrangham, who was one of its earliest lay members, and who presented some interesting Roman tiles to the museum. Hitherto, in addition to the officers and elected members of the council, the past presidents have been members *ex-officio*, four fellows and one associate being elected. In future, according to Rule 7 as altered, only the ex-president—that is, "the latest past president," will be retained on the council without election, in addition to the officers and the elected members—viz., four fellows and two associates. In consequence of the valuable additions recently made to the library, it has been thought advisable to insure the society's property from fire; and in order to admit of the free use of the books, three members have, at the request of the council, kindly consented to take charge of the library—

viz., Messrs. L. D. Hemsoll, S. D. Chipling, and W. J. Beall. The lectures of the session now closing have been of high character, as proved by the greatly-improved attendance, averaging double that of former years. A visit was paid, by invitation of Messrs. J. Grayson Lowood and Co., Limited, to their extensive brickworks at Deepcar, and the annual excursion was made in June to Chatsworth. Shortly after the last annual meeting the honorary secretary convened a meeting of associates and students to consider the best way of organising classes for the study of scientific subjects. A series of class lectures by Mr. Hugh Stannus, F.R.I.B.A., Lecturer at the Royal College of Art, was arranged, and 43 students attended the course, which dealt with Mouldings, Walls, and the Order. The honorary secretary, Mr. C. J. Innocent, some time ago intimated to the council that he wished to be relieved of the duties of the office at the end of the present year. The council asked him to reconsider the matter, but he thinks that other members should have the opportunity of working for the society. The following officers have been elected for the ensuing year:—President, Mr. R. W. Fowler; vice-president, Mr. J. Smith; hon. treasurer, Mr. F. Fowler; hon. secretary, Mr. W. C. Fenton; council: Messrs. C. Hadfield, E. M. Gibbs, C. J. Innocent, T. Winder, A. Smith Denton, J. R. Wigfull, and J. B. Mitchell-Withers.

### CHIPS.

Mr. Marcus Houghton, who built the Roman Catholic cathedral and a number of other prominent buildings in Springfield, Mass., died there on April 11.

The long dispute as to the proposed building of a new tower for Liskeard parish church appears to have been settled, amended plans by Mr. John Sansom having been adopted by the vestry, who have petitioned the Chancellor of the Diocese to issue a faculty. The revised design shows a tower 85ft. in height (as against 59ft., the height of the tower which has been condemned as dangerous, and partially demolished by the borough surveyor); it is finished with a single angle-turret, and is estimated to cost £3,000.

The corporation of Bradford have under consideration a proposal to erect an art gallery over the market extensions, and if the two committees concerned agree on the scheme, it is proposed to throw the plan open to public competition.

On Saturday a stained-glass window, put into Heptonstall Church, near Hebden Bridge, by the Prince Frederic Lodge of Freemasons, was unveiled. The window is a four-light one, and depicts the dedication of a temple, as recorded in II. Chronicles vi. 12, 13. The window has been inserted in celebration of the sixty years' reign of Queen Victoria.

A new public road leading from the village of Sternfield, near Saxmundham, to Snape, Iken, and Orford, was formally opened on Wednesday week. It forms a Jubilee memorial, and replaces a narrow and steep lane, and has been carried out for the subscribers and local landowners by Messrs. Baldry and Newson from plans by Mr. Henry Miller, the county surveyor of Suffolk.

One of the best known figures in Somerset, Devon, and Dorset has been removed by the death of Mr. Frank Tooze Hussey, F.S.I., of The Grove, Cheddon Fitzpaine. Mr. Hussey died at his residence from heart disease. He was 53 years of age, and had been steward for Lord Portman's Somerset and Devon estates since 1883, and was appointed sole agent on the death of Mr. Henry Parsons, of Misterton.

There was erected on Friday in Lasswade churchyard, N.B., over the grave of the late Rev. Dr. Walter Gregor (1825-97), of Pitlago, a monument of unpolished red granite. In form it is a Celtic slab, resting upon a basement of three massive steps, in reproduction of the early Scottish style of sculptured stone slabs. On the upper part of the stone is an ornamental Celtic cross set in a panel, and beneath runs the inscription carved in raised letters. The monument was designed and executed by Messrs. McGlashan and Son, sculptors, Edinburgh.

It was reported to the City Court of Common Council at the last meeting that the cost of the new office erected by the late Commission of Sewers in Basinghall-street was £20,700. The contractors were Messrs. J. Chessum and Sons.

Next month application is intended to be made to the Light Railway Commissioners (under the provisions of the Light Railways Act, 1896) for powers enabling the promoters to construct light railways in and between Redditch, Headless Cross, Crabb's Cross, and Astwood Bank.

**TO CORRESPONDENTS.**

[We do not hold ourselves responsible for the opinions of our correspondents. All communications should be drawn up as briefly as possible, as there are many claimants upon the space allotted to correspondents.]

It is particularly requested that all drawings and all communications respecting illustrations or literary matter should be addressed to the EDITOR of the BUILDING NEWS, 332, Strand, W.C., and not to members of the staff by name. Delay is not unfrequently otherwise caused. All drawings and other communications are sent at contributors' risks, and the Editor will not undertake to pay for, or be liable for, unsought contributions.

Cheques and Post-office Orders to be made payable to THE STRAND NEWSPAPER COMPANY, LIMITED.

**TERMS OF SUBSCRIPTION.**

One Pound per annum (post free) to any part of the United Kingdom; for Canada, Nova Scotia, and the United States, £1 6s. 0d. (or 6dols. 30c. gold). To France or Belgium, £1 6s. 0d. (or 3fr. 30c.). To India, £1 6s. 0d. To any of the Australian Colonies or New Zealand, to the Cape, the West Indies, or Natal, £1 6s. 0d.

**ADVERTISEMENT CHARGES.**

The charge for Competition and Contract Advertisements, Public Companies, and all official advertisements is 1s. per line of Eight words, the first line counting as two, the minimum charge being 6s. for four lines.

The charge for Auctions, Land Sales, and Miscellaneous and Trade Advertisements (except Situation advertisements) is 6d. per line of Eight words (the first line counting as two), the minimum charge being 4s. 6d. for 40 words. Special terms for series of more than six insertions can be ascertained on application to the Publisher.

Front-page Advertisements 2s. per line, and Paragraph Advertisements 1s. per line. No Front-page or Paragraph Advertisement inserted for less than 5s.

Advertisements for the current week must reach the office not later than 3 p.m. on Thursday. Front-page Advertisements and alterations in serial advertisements must reach the office by Tuesday morning to secure insertion.

**SITUATIONS.**

The charge for advertisements for "Situations Vacant" or "Situations Wanted" is ONE SHILLING FOR TWENTY-FOUR WORDS, and Sixpence for every eight words after. All Situation Advertisements must be prepaid.

**NOTICE.**

Bound copies of Vol. LXXIII. are now ready, and should be ordered early (price Twelve Shillings each), as only a limited number are done up. A few bound volumes of Vols. XXXIX., XL., XLI., XLVI., XLIX., LI., LII., LVIII., LIX., LXI., LXII., LXIII., LXIV., LXV., LXVI., LXVII., LXVIII., LXIX., LXX., LXXI., LXXII. may still be had, price Twelve Shillings; all the other bound volumes are out of print. Most of the back numbers of former volumes are, however, to be had singly. Subscribers requiring any back numbers so complete volume just ended should order at once, at many of them soon run out of print.

RECEIVED.—W. H. S. and Co.—M. B.—O. S. O.—R. S.—N. R. Co.—L. H. (Newport).—K. F. C.—A Victim.—M. B.—Anti-Com.—Subs.

**Correspondence.**

**KIRKHAM WORKHOUSE COMPETITION.**

To the Editor of the BUILDING NEWS.

SIR,—There are always two sides to a question. I should like you to give a Liverpool man's views. Mr. Crickmay has a son practising as a quantity surveyor, and naturally, he would prepare the quantities. Local builders are so unaccustomed to London quantities, that in the majority of cases that we have come across they have not got the contract, which we have known go to London (usually), or to the Midlands, or Scotland. These contractors naturally employ most of their skilled artisans from their own town, and as the guardians are spending public money, it is a case of disappointing local architects, local quantity surveyors, local builders, and local artisans; or of disappointing Messrs. Crickmay and Son, and we think they are wise in choosing ratepayers. It may be urged that they should limit the competition to local architects; but they want the best design they can get, and they should pay Messrs. Crickmay and Son for it, so that the whole or part may be incorporated in the building as carried out.

In some Yorkshire towns there is a combination between the builders and the quantity surveyors to defeat any London architect carrying out work if they insist on employing London quantity surveyors, and consequently giving an advantage to alien builders and workmen; but if Messrs. Crickmay think they can do better by going to law, by all means let them try. The guardians will have the full sympathy and support of the

ratepayers, whatever they have of the architectural world.—We are, &c.,

STEWART AND ASHWORTH.

41, Castle-street, Liverpool, April 26.

**DUKINFIELD TOWN HALL COMPETITION.**

SIR,—Having sent in plans for the above, we beg to be allowed to make a few remarks in reference to the award recently made by the district council as regards the first premiated design under motto "Astley."

Being amongst the unsuccessful competitors, we were anxious to ascertain in what respects we and others had failed, and with that intent we went over to Dukinfield to inspect the designs, which were publicly exhibited in the Technical School. There were twenty-two sets sent in by twenty-one firms, and according to a report which appeared in the Manchester and other local papers, "All the designs were of exceptional merit." What was our astonishment to discover that "Astley" had submitted two perspectives, alternative designs—both highly coloured, and framed and glazed into the bargain. The following are extracts from the Conditions of Competition and Instructions to Architects:—"The elevations and sections must be mezzotint or Indian ink, with no colour excepting the ashlar, which may be tinted light blue, or terracotta light red," "the whole of the drawings to be mounted on plain stretchers—no framed or glazed drawings will be adjudicated upon."

The council, in the instructions, reserved to themselves the right to call in an assessor to advise them in the selection. We need hardly say that no professional assessor was called in, a resolution by a member of the council, that one should be appointed, not finding a seconder.

From a close inspection and comparison of the plans, we have no hesitation in saying that the limit of cost (£7,000) would be very largely exceeded if either of the designs by "Astley" were carried out as shown by the perspectives; and, judging by the reports in the local press, this appears to be recognised, as the cost is therein put down at £10,000.

As the designs sent in hailed from London, Manchester, Liverpool, and other large towns at a distance, it is hardly likely that many of the competitors would have the opportunity of knowing what had been done; and we think it only right that those who are conversant with the facts should enter a protest against such a flagrant act of injustice, and not to allow such an insult to the profession to go unnoticed.—I am, &c.,

April 26.

FAIRPLAY.

The partnership hitherto subsisting between Mark H. Judge and H. G. Gardner, sanitary surveyors, architects, and engineers, Pall Mall, S.W., under the style of Mark Judge and Gardner, has been dissolved.

The Unopposed Bill Committee of the House of Commons have passed the Various Powers Bill of the Mersey Docks and Harbour Board, under which power is given to the board to borrow £1,400,000 "for the purpose of recouping to revenue the moneys advanced" for the completion of already authorised works.

The temporary iron church known as St. Paul's, North Shore, Blackpool, is about to be replaced by a permanent structure. The committee have already built a vicarage, and a large Sunday-school is now in course of erection, which will be opened in June. The plans for all the above buildings have been prepared by Messrs. Garlick and Sykes, of Preston and Blackpool, and the contractors are Messrs. Joseph Fielding and Sons, of Blackpool.

The tower of the parish church of Ashill, Norfolk, is being restored. The whole of the upper portion is to be taken off, and a new parapet of Ketton stone and flint, with the addition of string-courses and moulded battlements, put on. The whole of the timbers and leadwork are to be new. At the completion of the work to the tower the bells are to be rehung. The work is being carried out by Messrs. Waters and Son, builders, Watton, Norfolk. The plans are by Messrs. Milne and Hall, architects, London. The church has recently been fitted with hot air apparatus.

The renewal of business at the Auction Mart last week was marked by exceptional activity, and the attention of investors has been directed more strongly than ever to investments in house property, which are not subject to violent daily fluctuations. The supply, moreover, was uncommonly good last week, and the highly satisfactory aggregate of £214,791 was recorded, a considerable figure at this early period of the season.

**Intercommunication.**

**QUESTIONS.**

[1937.]—**Powder Magazine.**—Shall be glad if some kind and able readers could give particulars of construction of powder magazine. How is the roof generally constructed?—ENQUIRER.

[1938.]—**Skittle Alley.**—Would some reader of the BUILDING NEWS inform me where information regarding size, construction, and cost of building a skittle alley can be obtained? Is there any book on the subject?—E. B.

**CHIPS.**

The Jubilee clock-tower at Kingswood, near Bristol, is on the eve of completion. Mr. T. Mackay is the architect, and Mr. A. Amos the builder.

Messrs. Doulton's pottery works at Burslem were partly destroyed by fire on Friday, the loss amounting to £10,000.

At Colne, Lancs, on Friday, a Local Government inquiry was held into an application by the corporation to borrow £10,000 for purposes of efficiently sewerage and paving Keighley and Albert roads, two principal highways, also £1,200 with which to decorate and fit up the town-hall internally with requisites. There was practically no opposition.

The new duplicate pumping engine of the Ipswich Corporation waterworks was formally started on Thursday in last week. It is a triple-expansion Worthington, designed to pump two million gallons in 24 hours, and was constructed, like the fellow horizontal engine built in 1893, by Messrs. Simpson and Co., of Pimlico. The new building for engine and boiler has been erected by Mr. Chas. Borrett, of Ipswich, from plans by Mr. Hamlet Roberts, the water engineer to the Ipswich Corporation.

The formal opening of a new infant school, belonging to the Ruabon United District School Board, took place on Thursday in last week at Rhosllanerchrugog, Ruabon. The cost of the building was £4,000.

A new drinking fountain, erected in honour of the Diamond Jubilee, will be inaugurated at Curdridge, Hants, next week. It has been erected by Messrs. Garrett and Haysom, of East-street, Southampton.

At the Birkenhead Police-court, on Friday, Messrs. J. Lloyd Jones and Co., Lord-street, Liverpool, were summoned to show cause why a distress warrant should not be issued on account of certain moneys due to the corporation for improvements done to private streets adjoining their property. The sums amounted to £118 11s. 5d. Defendants contended that the improvements were unnecessary, but judgment was given against them.

At the end of last year the corporation of Shrewsbury applied to the Local Government Board for power to borrow £48,000 for the purpose of a new water supply, and a lengthy Government inquiry into the question was the result. The Local Government Board has now intimated its refusal to sanction the loan.

A start was made last week with the restoration of the tower and the re-casting and re-hanging of the peal of bells at the parish church of All Saints, Northallerton. The work has been intrusted to Messrs. J. Warner and Sons, of London. In addition to re-casting two of the old bells and retuning the whole peal, Messrs. Warner and Sons will provide eight sets of new bearings and gudgeons and a new set of ropes.

The adjudication in bankruptcy is announced of Henry George Curry, Charles Edward Simpson, and William Alfred Curry, described in the receiving order as Curry, Simpson, and Curry, of Walbulton-road, Brockley, S.E., builders.

A Committee of the House of Commons has passed the Bill promoted by the Ipswich Dock Commissioners for powers to construct additional bridges, landing stages, tramways, and other works in connection with their dock undertaking. For the execution of these works the commissioners are empowered to borrow a further sum of £35,000 upon mortgage of the rates and duties leviable by them. As regards the proposed tramways, provision is made in the Bill for their construction and maintenance by the Great Eastern Railway Company, who are empowered to use locomotives on the tram lines subject to the consent of the commissioners and the Corporation of Ipswich.

Memorials to two celebrated sanitarians, Sir Edwin Chadwick and Sir Benjamin Ward Richardson, are being promoted by the Sanitary Inspectors' Association. The object is to provide funds sufficient to give annual premiums, in money, books, medals, &c., to students in sanitary science at technical colleges. Sir John Hutton, president of the Sanitary Inspectors' Association, has contributed £52 10s. to the fund, and an anonymous donor has given a like amount.

## LEGAL INTELLIGENCE.

IS A CONTRACTOR'S STONEYARD A "NUISANCE"?—**HOWLAND V. DOVER HARBOUR BOARD.**—In the Court of Appeal, on April 22, before the Master of the Rolls, Lord Justice Rigby, and Lord Justice Collins, decision was given in an appeal from a decision of Mr. Justice Romer. The action was brought by a lady who was the owner of Connaught House, a private hotel in Waterloo-crescent, Dover, for an injunction and damages in respect of nuisance and injury caused by the defendants' works on an open space immediately in front of her premises. The defendants, who were the Harbour Board and their contractor, were using the space for works in connection with the construction of the new break-water, and the plaintiff complained of the noise and vibration, which, she said, had caused cracks in the fabric of her house, and driven away her customers. Mr. Justice Romer, although satisfied that the plaintiff had suffered considerable annoyance, held that it did not amount to a nuisance at law, and he dismissed the action. The plaintiff appealed, but she did not either in the Court of first instance or upon the appeal insist upon her right to an injunction. The Court allowed the appeal. The Master of the Rolls thought that the learned Judge had minimised the evidence of nuisance adduced on behalf of the plaintiff. The Harbour Board were authorised by Act of Parliament to construct a new harbour, and for this purpose huge blocks of concrete were required. The contractor had obtained from the Harbour Board a piece of land where he manufactured these blocks of concrete, and he also obtained from them the right to use the piece of vacant land in front of the plaintiff's house for the purpose of storing the concrete blocks. The mere fact that this vacant piece of land was turned into a stoneyard caused a considerable amount of damage to the plaintiff's business as an hotel-keeper, but for that she had no right to damages because there was no actionable injury. The contractor had done no more harm than was reasonably necessary for the purpose for which the land was acquired. It was necessary, in order to move these heavy blocks, to lay down a tramway and to employ steam-engines and steam-cranes, and the result of all this had been very serious to the plaintiff. The principles to be applied in a case of this kind were laid down by Lord Justice Mellish in "Ball v. Ray." His Lordship thought that the evidence showed clearly and distinctly that both the comfort of the plaintiff's house and also the plaintiff's trade as a lodging-house keeper had been seriously interfered with by the defendants' operations, quite apart from the annoyance which the plaintiff had suffered by having a stoneyard next her house instead of a vacant piece of land. Then the question was, who was liable? The injunction had been waived, and it was a question of damages only. The contractor was liable, of course; but were the board liable also? If a contractor was employed to do a piece of work, the employer was not liable for what might be called collateral negligence on the part of the contractor. But here there was no question of negligence. The principle upon which the board were responsible was that they had allowed the contractor to use this piece of land for the very purpose to which he applied it, and the necessary consequence of that, in the ordinary business sense of the word "necessary," was a nuisance. In other words, the board committed the nuisance by their contractor. The appeal should be allowed, and judgment should be given for the plaintiff against both defendants, the amount of the damages to be assessed by an official referee. Lords Justices Rigby and Collins gave judgement to the like effect.

**LIABILITY TO REPAIR FOOTBRIDGES.**—**CUCKFIELD RURAL DISTRICT COUNCIL V. GORING.**—In the Queen's Bench Division, on Monday, before Mr. Justice Wills and Mr. Justice Kennedy, judgment was given in an appeal by the defendant from the decision of the County-court Judge of Sussex sitting at Worthing. The action was brought under section 25 (2) of the Local Government Act, 1894, which provides that "where a highway repairable *ratione tenuræ* appears on the report of a competent surveyor not to be in proper repair, and the person liable to repair the same fails, when requested so to do by the district council, to place it in proper repair, the district council may place the highway in proper repair, and recover from the person liable to repair the highway the necessary expenses of so doing," to recover the cost of repairs executed by the plaintiff council to two foot-bridges which, it was alleged, the defendant was liable to repair *ratione tenuræ*, as owner of two farms. The learned County-court Judge held that a liability to repair the foot-bridges attached to the farms in question, and he further held that under section 25 (2) of the Local Government Act, 1894, proceedings might be taken against the owner of lands to which such an obligation attached, and he gave judgment for the plaintiffs. The defendant appealed. Mr. R. E. Moore appeared under the enactment in question could only be taken against the occupier of the lands subject to the

liability, and he cited "Reg. v. Barker," "Baker v. Greenhill," Mr. Dickens, Q.C., and Mr. Boxall, on behalf of the plaintiffs, argued that although an indictment for non-repair can only be preferred against the occupier, still the ultimate liability is upon the owner, who is liable to reimburse the occupier the expenses incurred in repairing the way. They pointed out that in "Baker v. Greenhill" Lord Denman spoke of the owner as the person who "ought to have repaired." They also cited "Reg. v. Bucknell." The Court allowed the appeal. Mr. Justice Wills said he failed to understand the argument for the respondents, and felt no doubt on the matter. At the passing of the Local Government Act, 1894, it was well-established law that the occupier of land subject to a *ratione tenuræ* liability for the repair of highways is the only person who can be made to perform the obligation. As Lord Coleridge said in "Reg. v. Barker" that a proposition had been established from the time of Rolle's Abridgment, where (p. 783) it is laid down both in the positive and negative that you must indict the occupier and cannot indict the owner. The passage in Rolle's Abridgment did not in terms refer to highways repairable *ratione tenuræ*, but in subsequent cases it had been pointed out that it was intended to refer to such highways. There was, therefore, old authority for the proposition that the occupier is the only person against whom the liability can be enforced. As between the owner and the occupier, the occupier no doubt had a right to be reimbursed; but that was a matter as between them with which the public had no concern. It was suggested, on the strength of the chance expression in "Baker v. Greenhill," "the owner who ought to have repaired," that there was, what all the authorities had repudiated, a liability on the owner's part to repair, as distinguished from a liability to reimburse the occupier the expenses incurred by him in repairing. But his Lordship could not accept that suggestion. Then section 25 (2) of the Act of 1894 simply provided a new and less cumbersome means of getting repairs done and paid for. It was, therefore, quite clear that the proceedings were misconceived, and the appeal must be allowed. Mr. Justice Kennedy concurred.

**GAS REFUSE AND RIVER POLLUTION.**—A Divisional Court of the Queen's Bench, on Saturday, heard an appeal by the corporation of High Wycombe against a conviction of them by the local magistrates, at the instance of the Conservators of the River Thames, for wilfully suffering offensive matter to pass through their sewage works into the River Wye, a tributary of the Thames, whereby a number of fish were killed. The offensive liquid came from the gasworks, and the Gas Company had been proceeded against and fined. The corporation contended that they had not been guilty of any wilful suffering of the pollution, and Justices Grantham and Kennedy, arriving at the same conclusion, quashed the conviction.

**MAIN DRAINS V. SEWERS.**—**BLUNDELL V. PRICE.**—This case came on Monday for argument on appeal from the Birmingham Police-court, before Mr. Justice Wills and Mr. Justice Kennedy, sitting as a Divisional Court in the Queen's Bench Division. Mr. Lawson Walton, Q.C., M.P., who appeared for the appellant, said this was an appeal by way of special case from a decision of the justices of Birmingham, and the question was whether the system of drainage which was organised by the appellant in regard to some new buildings was or was not adequately ventilated in accordance with the by-laws of the corporation of Birmingham. Mr. Justice Wills: He says they are main drains, and not sewers. Does it not come under the Public Health Act? Mr. Walton said there was a section which no doubt applied to the matter, but there was a by-law which had been specially framed. Mr. Justice Wills said under the Public Health Act there never was much difficulty in saying what a drain was. Mr. Walton said there was no doubt that a drain which drained more than one building was a sewer. The by-law qualified the generality of the statutory definition. The case stated that the appellant was charged upon an information of the Corporation that on October 13, 1897, at Charles-road, he did unlawfully break the by-law in question, No. 61, by neglecting to provide for a main drain for certain new buildings then being erected on the west side of Charles-road a suitable trap for ventilation as provided by the by-law in question. There were a block of new houses belonging to one owner all being built at the same time. The contention of the appellant was that the whole of the sewage pipes belonging to these six houses were, strictly speaking, a drain: that was, although they communicated with the main drain down a passage, yet all the pipes retained their character of drains as distinct from a sewer. Mr. Justice Wills: The appellants want to make one ventilating trap do for each three houses, and the Corporation want a trap for each house. Mr. Walton said that was exactly the point, and it was more or less a question of expense. The Corporation said that to each pipe, shortly after it left each house there ought to be a separate

ventilating trap, and there ought to be six in place of two, which the appellants proposed to make. He contended that under the circumstance by-law 61 had been sufficiently complied with. Mr. Justice Wills said he could not persuade himself that there was any doubt about the case, and he thought the magistrate had come to a right conclusion. There was only one question in these cases, and that was what was the meaning of the word "drain" in the 61st by-law, and what was the meaning of the word "sewer," and how these two terms were to be applied. The definition of the Public Health Act, which was the one that governed the case, was that a drain was a drain so long as it received the drainage of one house, but directly it received the drainage of two houses it became a sewer. The appeal must therefore be dismissed, with costs.—Mr. Justice Kennedy concurred.

**RE FRANCIS MORTON AND CO., LIMITED (IN LIQUIDATION).**—The adjourned hearing of the petition presented by the Pearson and Knowles Coal and Iron Company, Limited, for the compulsory winding up of this company, or in the alternative for the winding up under the supervision of the Court, came on on Monday. Unsecured creditors to the amount of over £16,700, and also the second debenture holders, appeared in opposition to the petition, and urged that it should be dismissed. The Vice-Chancellor held that in the absence of complete particulars he was not in a position to give a decision and make an order. He accordingly directed the matter to stand over until the end of July next, in order to allow an opportunity of completing negotiations for the sale of the business as a going concern.

**DEAUDING THE MANCHESTER CORPORATION.**—At the Manchester Quarter Sessions, on Wednesday, John Tetlow, 40, managing director of John Tetlow and Sons, contractors, Littleborough, and David Hallard, 53, clerk in the paving department of the Manchester Corporation, pleaded "Guilty" to having conspired to defraud the corporation. Mr. Byrne, for the prosecution, said the evidence disclosed frauds extending over 10 years, amounting to £4,819. Tetlow had substituted for the correct accounts made out monthly by a clerk of his own firm other accounts that were in excess and Hallard had passed them. The excess sums were then divided between the two. Tetlow paid them into his private bank account, and drew on it for the correct sums due to his firm. Hallard, when arrested, told the police he had never received more than £30 in any month. Mr. O. Evans and Mr. Pope addressed the Court on behalf of Tetlow and Hallard respectively. The latter's salary was stated to be £2 a week, and he had been in the corporation's service for 22 years. The Recorder sentenced each of the prisoners to three years' penal servitude.

**PROPERTY COMPENSATION CASE IN STOCKWELL.**—At the Sheriff's Court, Red Lion-square, Holborn, on Wednesday, Mr. Burchell and a special jury heard the case of "Lady Mary Bacon's Executors v. the London School Board." This was a claim for compensation for the leasehold interest in houses Nos. 74 and 76, Santley-street, Stockwell, and for injuriously affecting the adjoining houses by the erection of a board school. The value of the two houses taken was estimated at £816, and the depreciation of the adjoining houses at £50 per house. The expert who gave evidence for the claimants were Mr. E. F. B. Fuller (Messrs. Fuller and Fuller) and Mr. J. T. Skelding (Messrs. W. W. Read and Co.); while those on behalf of the School Board were Mr. Samuel Walker (Messrs. Walker and Son), Mr. Henry Arthur Drew (Messrs. Drew and Sons), and Mr. Douglas Young (Messrs. Douglas Young and Co.) Sir William Marriott objected to any claim in respect of the probable depreciation of the adjoining property by reason of the user of the school as a school. He said the matter would shortly be argued at length before the High Court, and unless the jury adopted his witnesses figure of about £600 for the houses actually taken and confined their attention to that question, he must ask for the items to be specified in the verdict. The Under-Sheriff said the question was one of far-reaching importance, and, in view of the fact that the point would be dealt with in the High Court at an early date, he directed the jury to state the items of their verdict. The jury awarded the claimants £762 10s. in respect of the houses actually taken by the Board, and £100 in respect of the probable injury to the claimant's adjacent houses by the user of the school.

A window at the back of the altar in the chapel of St. Anne, on the south side of Malvern Priory, has been filled with stained glass depicting the history of the Priory. The artist is Mr. C. E. Kempe.

Application is to be made during May to the Light Railway Commissioners to sanction the construction of a 2ft. gauge light railway from Minehead to Lynmouth. The route has been surveyed and plans drawn. The length of the proposed line is 20 miles, and its cost including rolling-stock, is estimated at £5,000 per mile.

## WATER SUPPLY AND SANITARY MATTERS.

THE LONDON COUNTY COUNCIL (ACTON SEWAGE) BILL.—This Bill has been before the Select Committee of the House of Commons. The object of the Bill is to require the Acton Local Board, whose sewage passes through the Metropolitan main drainage system, to bear their share of the cost of the original construction of that system and its maintenance, the capital outlay having been some seven millions, and the annual cost of maintenance about a quarter of a million. Sir Alexander R. Binnie, the chief engineer of the London County Council, was examined, and on the conclusion of his evidence the chairman said the committee were unanimously of opinion that nothing in the nature of back charges—such as were provided for in Clause 5—should be entertained by them. The only question, therefore, that remained to be dealt with was whether or not Acton should contribute to the cost of the main drainage system since the date of the deposit of the Bill. Clause 5 was then struck out, and the committee heard the evidence of Mr. H. Law, C.E., and Mr. Ebbetts, surveyor to the Acton board. Mr. Costelloe, appearing for the Vestry of Chelsea, said that at the present time Chelsea suffered considerable inconvenience and damage from the overcharged state of the sewers, owing to the Acton sewage passing through their sewers, and they did not wish that more should pass through in the future. Mr. Higgins, C.E., surveyor to the Chelsea Vestry, was called, and gave evidence in support of this contention. Mr. Pope, Q.C., then addressed the committee for the London County Council, and contended that this was an equitable demand on the part of the Council that Acton should pay its fair share of the cost of the drainage system which it used. After the committee had deliberated, the chairman said the committee were unanimously of opinion that the Acton local authority ought to make some contribution to the expense of the London County Council in respect of that portion of their houses which transmit sewage into the London sewers without a prescriptive right to do so. But the committee thought also that a clause ought to be inserted in the Bill giving to the Acton Local Board the power within two years to exercise the right of disconnecting their sewers for other than land water from the London County Council sewers, and that from the time that work was done their payment to the London County Council should cease.

MANCHESTER.—Parliamentary powers were obtained under the Manchester Corporation Act, 1897, for laying an additional main pipe 30in. diameter from the Godley to the Audenshaw reservoirs, and, out of the total length of about 4½ miles, about 1½ miles have been laid. A new straining well has been constructed at Godley reservoir, and the branch 40in. main from this straining well to the existing 40in. main from the reservoir is also completed. The Thirlmere works have been maintained in full working order. The quantity of water supplied from Thirlmere during the last 12 months has been on the average about 7½ million gallons per day, out of an available quantity of 10 million gallons per day. All the contract accounts in connection with the construction of these works have now been settled, the award in the last arbitration for contract No. 7 having been made in February last.

## CHIPS.

The foundation-stone of the new church of St. Oswald, Fulham, was laid by Lady Edward Spencer-Churchill on Monday. The new district is being formed out of St. John's, Fulham, with a portion of St. Andrew's, West Kensington, and the church is one of those for which a grant is proposed to be made from the Marriott bequest.

The House of Commons rejected, on Monday, by the majority of 364 votes to 84, the second reading of the Victoria Embankment and St. John's Improvement Bill. The promoters of the scheme engaged, it will be remembered, Mr. R. Norman Shaw, R.A., as their architectural adviser, but not until rather late in the day.

Mr. David Stewart, for the past fifteen years master of works to the University of Glasgow, died at his residence in the University building in that city on Monday.

The Wirral Railway Bill, empowering the Wirral Railway Company to make railways and other works at Wallasey, forming junctions with the Seacombe branch railway and the railway authorised by the Company's Act of 1895, passed the committee stage in the House of Lords on Monday. The Bill provides for the improvement of the line in Wallasey.

The great fire in Glasgow was successfully got under on Tuesday. The firemen succeeded in saving St. Andrew's Roman Catholic Cathedral, which was in imminent danger of destruction. Part of the roof of the edifice, however, was burned, and the vestry damaged.

## Our Office Table.

OUR readers will not have failed to notice that on Thursday afternoon in last week a lamentable fatal accident, involving the loss of seven lives, occurred at Abbey Mansions, Victoria-street and Orchard-street, Westminster, illustrated in our last issue. The catastrophe resulted from the collapse of the concrete roof, from which the wooden supports were being removed, and this, falling through all the floors, carried an immense quantity of debris into the basement. Six workmen were killed outright, another has since died, and about twenty were more or less seriously injured. The building was erected for Her Majesty's Office of Works, by whom it had been leased for 21 years for use by the Civil Service Commission as offices. It is a building of nine floors and about 300 rooms, and was erected by Mr. W. R. Rickard, contractor, of City-road, at a cost of £95,000, from the designs of Mr. C. J. C. Pawley, architect, of 2, Prince's-mansions, Victoria-street. There were, however, a number of sub-contractors. Quite recently that portion of the building which has collapsed was certified by the district surveyor as "completed" for rating purposes. The construction of this portion had been delayed owing to a question of ancient lights raised by the owners of the Catholic Apostolic Church in the rear. The inquest was opened on Monday, and, after evidence of identification, adjourned for a fortnight, for the production of an expert report by officials of the Home Office. At a meeting convened by the chairman of the Westminster Vestry, it was resolved to inaugurate a fund for the relief of the families of the dead and injured men.

THE School Board for London recently received a communication from the Education Department containing a series of revised proposals as to sanctioning loans for works to schools. Their lordships desire to place loans upon a new basis, on the grounds that:—(1) It is desirable that the £10 limit should be applied to all ordinary expenditure. (2) The extra expenditure necessitated by the peculiar circumstances of London schools should be excluded from the £10 limit; and the loan for such things as latrines, drainage, and tar pavement should not be for a longer period than the provision will last. (3) Generally to place the department in general agreement with the school board as regards loans and allowances, so as to avoid the recurrence of difficulties. Their lordships are therefore of opinion that, in future:—(1) The £10 limit should include the whole of the building proper, exclusive of central halls, its warming apparatus and ventilation, as well as teachers' rooms, but not including any additional cost for the use of glazed bricks internally. (2) That the London School Board should be allowed a separate amount over the £10 limit for latrines and drainage, tar pavement, and boundary walls; but that this provision (except as regards boundary walls) should be the subject of a loan for a shorter period than 50 years—say 30, both in the case of new schools and subsidiary work for existing schools. (3) That the provisional amount for contingencies should be limited to the building contract itself, and should not exceed 2½ per cent., instead of 5 per cent. as hitherto allowed. At the meeting of the School Board held yesterday (Thursday), it was decided to reply to the department, stating that the board are prepared to accept these proposals, and that they assume that the arrangements hitherto in force, by which the cost of the following items, when they are rendered necessary, will be allowed as outside the £10 limit, are to be continued:—(i.) Expenditure for extra depth of foundations; (ii.) expenditure for works on site, or works to existing buildings; (iii.) the extra cost of erecting buildings on arches, when this is considered necessary, in order to avoid the purchase of additional land; and (iv.) the cost of providing playgrounds on roofs, also in order to avoid the purchase of additional land.

THE Housing of Working Classes (Rural Districts) Bill, brought in by Sir W. Foster, Mr. Channing, and others, proposes to amend the Housing of the Working Classes Act, 1890, as regards rural districts only, in the following manner:—(a) To place a rural authority on the same footing as an urban one with regard to the adoption of the Act, and also (as in the case of an urban authority) to make the Local Government Board, instead of the County Council, the

sanctioning authority in many matters. (b) To simplify the power of purchase of land, by giving to the rural district council the same power of purchase for cottages that a parish council already possesses, under the Local Government Act, 1894, for those purposes for which a parish council is empowered to buy land, subject, however, to this difference—that the preliminary inquiry shall be conducted by the Local Government Board instead of by the county council. The Bill also gives power to hire land compulsorily. (c) The Bill provides that the size of a cottage plot may be one acre (as in Ireland under the Labourers Acts), instead of being limited to half an acre; also that the local authority may usually borrow, for 50 years, for providing cottages. Power to complain of lack of cottages is given to parish councils, the medical officer of health, or four neighbouring householders. When land is provided cottages may be erected by and placed under the management of a parochial committee, if the rural authority so determine. Both in the principal Act and this Act, the phrase "lodging-houses for the working classes" includes houses or cottages.

THE Museums Committee, at their meeting on Tuesday, decided to bring forward immediately an *ad interim* report recommending the removal of the Jermyn-street Geological Museum to South Kensington. They will also strongly recommend that the Science and Art Departments shall be housed on opposite sides of the way, instead of side by side. It is understood that the decision to issue an immediate report is due to certain rumours as to the intentions of the Office of Works with regard to the Science and Art collections.

THE members of the Metropolitan Asylums Board reconsidered, on Saturday, a letter from the Local Government Board forwarding a copy of a report by the district auditor in connection with the audit for the half year ended Michaelmas last upon certain accounts of the Brook, South-Western, Park, and Grove Hospitals. The Local Government Board only sanctioned an expenditure of £200,000 in connection with the Brook Hospital, whereas the Asylums Board had spent £284,129, being an excess of £84,129. Moreover, the auditors had detected the facts that £38,000 worth of work was ordered by the architect on his own responsibility, without the sanction of the board or any committee, and that £50,000 had been paid to contractors in excess of their contract prices. The alterations and additions at the South-Western Hospital, contracted for at £26,976, had cost £30,879, and work involving a cost of upwards of £3,000 had been carried out on the order of the architect without any authority from the board. The letter was referred to the Finance Committee. Mr. Lobb moved: "That having regard to the fact that the total amount paid by the managers to architects and quantity surveyors during the last four years ended at Lady Day, 1897, was £63,683 9s. 7d., the question of the appointment of an architect to the board be referred to the General Purposes Committee for consideration and report." After some discussion, the managers voted upon the motion, the result being that the voting was equal—namely, 15 for and 15 against. The chairman then gave his casting vote against the motion, which was accordingly lost.

AN exhibition of water-colour drawings was opened on Saturday in the Camphill Gallery of the Glasgow Corporation. It consists of the first circulating collection of works of water-colour artists of the British school selected from South Kensington Museum with the view of illustrating the rise, progress, and present position of the art. It embraces about 300 separate works, selected examples of the finest and most characteristic productions of the various pioneers of water-colour drawing, and of their successors, who have carried this branch of art to its highest perfection. Water-colour drawing, as now understood, may be said to belong exclusively to the 19th century. In earlier days water-colour pictures were really tinted drawings, hence the name drawing which obstinately adheres to water-colours. From 1800 onwards, under the influence of Girtin and Turner, the art became really painting. This and many more important points are well illustrated in the collection, which contains works in the earlier manner by George Barret, sen., R.A., Gainsborough, Paul Sandby, R.A., Isaac Cruikshank (the father of George), Thomas Hearne, John Robert Cozens, and Julius Caesar Ibbetson, &c. The works of all the great early practitioners of the modern method of

water-colour painting are well illustrated, among the names known to fame being Girtin, Turner, Old Crome, John Sell Cotman, Italian Smith, Wm. Blake, Bonington, Varley, George Barret, jun., Wm. Henry Hunt, Cox, De Wint, &c. Among the recent exponents of water-colour painting, there are examples of Sir James D. Linton, Sir John Gilbert, Henry Moore, Rossetti, Randolph Caldecott, and many others. The collection will remain on view at Glasgow for the next three months.

A SMALL collection of autographs and letters has been added to the galleries in Queen-street, Edinburgh, of the Scottish National Portrait Gallery. The most attractive are manuscripts by Robert Burns, which range from what is supposed to be the earliest specimen of his writing, to a letter addressed to Alexander Cunningham, written about a fortnight before the end, and, in character, from entries on Excise vouchers and notebooks to impassioned letters and some of his most famous verses. There are also letters written by Scott, Jeffrey, Lockhart, Macaulay, Campbell, "Tom Cringle" (Michael Scott), and Watson Gordon. There is also a selection of historical autographs, including those of all the Stuart sovereigns except Mary of Orange. Through an arrangement with the National Gallery of Scotland a number of portraits, including oil-paintings, miniatures, and medallions, have been transferred to the Scottish Portrait Gallery.

Memorial stones of a new Sunday-school in connection with Ventnor-street Methodist New Connexion Chapel, Kirkstall-road, Leeds, were laid on Saturday. Mr. W. S. Braithwaite, of Leeds, is the architect. The building will be of brick, with stone facings. There are two stories. The ground floor will be used as an assembly-room, the upper floor will provide a preaching-room and six classrooms. The new school will accommodate about 350 scholars, and will cost £1,350.

The marriage of Mr. F. F. McKenzie, the superintendent of Epping Forest, and the son of the late Major McKenzie, to Miss Jane Miller Reid, daughter of the late Mr. John Reid, of Old Clock House, Enfield, was solemnised at the parish church, Enfield, on Wednesday in last week. The City Court of Common Council gave the bridegroom a handsome present from the pockets of the ratepayers on the day after the wedding by voting him an increase of salary from £500 to £600 a year.

The new Free Library and Art Gallery at Huddersfield were opened by the Marquis of Ripon on Friday. The premises, which are in Church-street, have been granted by Sir J. Ramsden for ten years at a nominal rental, and have been fitted up at a cost of £900, while another £700 has been expended on books. Till now Huddersfield has been almost the only corporate borough in the kingdom without a public library.

A new tramway line has been opened in Leeds this week. The route is from the Corn Exchange, along York-street and Beckett-street to the Cemetery, and thence to the junction of Harehills-road and Roundhay-road. Part of the line was formerly worked by the Thomson-Houston Company, but for some time it has not been used. The corporation have had to lay a new line from the corner of York-road, along Beckett-street, as far as Green-road, in order to connect the lines which were in existence, and make the system complete. A new route to Roundhay Park is thus opened up.

The City Corporation have adopted an arrangement for acquiring the freehold of Nos. 1 to 4, Cheap-side, and 1A, Paternoster-row, for the sum of £22,542, in accordance with an award of Mr. Robert Vigers. This will allow of a substantial and much-needed widening at a very congested corner.

On Sunday Cardinal Logue laid the foundation-stone of a new Roman Catholic church at Tully-allen, which is only a short distance from the noble ruins of Mellifont. The new church, which, apart from its interior fittings, is to cost about £3,500, is to be in the same style of architecture as the neighbouring ruins, and is being erected from designs by Mr. W. H. Byrne, of Dublin.

A Local Government Board inquiry was held in the Town-hall, Newcastle, on Wednesday, to consider the application from the corporation for sanction to borrow £2,140 for public library purposes, and £60,000 for the extension of the City Lunatic Asylum.

The Roman Catholic Cathedral at Westminster is making steady progress. Mr. J. F. Bentley is the architect, and the builders are Messrs. Shillitoe and Son, of Bury St. Edmund's. £43,807 has already been spent, and a further sum of £22,573 will have been spent in six or seven months. What the total cost will be is not yet known, as the cathedral is being built by schedule.

### MEETINGS FOR THE ENSUING WEEK.

MONDAY.—Royal Institute of British Architects. Annual General Meeting, 8 p.m.  
Surveyors' Institution. Discussion on "Tithe Rent Charge Recovery," 8 p.m.  
Society of Arts. "The Electric Locomotive," Cantor Lecture No. 1, by Prof. Carus Wilson, 8 p.m.  
Society of Engineers. Discussion on "The Protection of Underground Water Supplies," Royal United Service Institution, 7.30 p.m.  
Liverpool Architectural Society. Annual Meeting. Closing Address by the President, W. E. Willmill, M.A.

TUESDAY.—Society of Arts. "Senefelder and the Centenary of Lithography, 1798-1898," by Joseph Pennell, 8 p.m.

WEDNESDAY.—Society of Arts. "The Revival of Hand-Loom Weaving," by Miss Clive-Bayley, 8 p.m.  
Edinburgh Architectural Association. Annual Meeting and President's Valedictory Address, 8 p.m.  
Edinburgh Architectural Society. "Evolution of the Modern House," by A. N. Paterson, M.A., of Glasgow, 8 p.m.

### THE ARCHITECTURAL ASSOCIATION.

MAY 6th, ORDINARY MEETING, 9, Conduit-street, W., 7.30 p.m. Papers by Mr. W. ECKSTEIN, C.E., on "INTERIOR LIGHTING" (Reflected Lights) and Mr. TOM EKIN on "ELECTRIC LIGHTING AS APPLIED TO ARCHITECTURE."  
Nominations of Officers for Session 1898-99.  
MAY 7th, SPRING VISIT to the Crown Theatre, High-street, Peckham, Mr. Ernest A. Runtz, Architect. Meet at building 3 p.m.  
E. HOWLEY SIM } Hon. Secs.  
G. B. CARVILL }

### CHIPS.

In the case of Bennet Milward, Sutton, and Myddleton-road, Bowes Park, N., builder, the discharge from bankruptcy has been suspended for five years, ending March 29, 1903.

The foundation-stone of the clock-tower now in course of erection at the end of Queen-street, Exeter, was laid on Friday by Mrs. Miles, the donor. Mr. T. A. Andrews is the architect, and Mr. Easton the contractor. It is hoped to get the tower and clock completed by the end of July.

An inquiry was held at the parish-room, Lustleigh, on Tuesday morning by Colonel A. J. Hepper, D.S.O., R.E., an inspector from the Local Government Board, into an application by the Newton Abbot Rural District Council to borrow £1,000 for the provision of a water supply for Lustleigh.

The wooden island pier situated to the west of Blackfriars Bridge, on the Surrey side, is being demolished, and will soon vanish from the river. During the four years it has been in position it has served as the chief base of operations in connection with the construction of the Waterloo and City Railway. The earth and rubbish excavated in the subway have been removed from this point, and the material required for the work below has been lowered down temporary shaftings.

Sir Joseph Fayrer, F.R.S., has accepted the presidency of the 17th congress of the Sanitary Institute, to be held in Birmingham, commencing on Sept. 27th.

A building, which has been erected at the junction of Main and Lorne streets for the Club, Campbelltown, from designs by Mr. H. E. Clifford, Glasgow, was opened on Friday. The reading-room is on the first floor, and the billiard-room on the second floor.

While making some excavations in a garden in Grantham Grange some workmen struck stone, and digging deeper unearthed the base of a solid quatrefoil pillar, with decorated moulding. The pillar, measuring 2ft. 4in. across, stands on a block of stone 6in. deep, which may either be a stylobate or a portion of a floor. The stone is a local formation, such as is now found at Ponton and Heydour. In pre-Reformation times a monastery stood in the Grange, but its position could never be exactly determined. Further excavations are to be made.

A conference of churchmen was held in Manchester on Friday, under the chairmanship of the bishop, to take steps to carry out the recommendations of his lordship's recent commission of inquiry into the spiritual needs of Manchester and Salford. According to the commission, £48,000 is needed to build sixteen churches, at a cost of £3,000 each, besides £20,000 for sites, and £12,000 for mission-rooms, together with £4,000 a year for clerical and lay help. A resolution was passed that an effort should be made to raise the needed money during the next five years. Before the meeting closed, it was announced that £24,600 had been promised to the object.

The Lanarkshire and Ayrshire Railway Company have let the contract for their new line from Giffnock to Giffen to Messrs. Robert M'Alpine and Sons, of Glasgow. The contract price is about £200,000, and the length of the line about fifteen miles. This firm has made the whole of the Lanarkshire and Ayrshire railways.

## Trade News.

### WAGES MOVEMENTS.

ABERDEEN.—The recent decision of the Board of Conciliation in raising the standard rate of plaster-labourers' wages from 5d. to 5½d. per hour has been formally communicated to a meeting of the Master Plasterers' Association. The meeting expressed keen dissatisfaction with the decision, which was declared to be at variance with the evidence submitted.

DRIFFIELD.—The master bricklayers of Driffield have come to the men's terms, after a strike lasting a fortnight, and agreed to advance wages from 6d. to 7d. per hour. Most of the men have left the town, and obtained work elsewhere at higher wages still.

MAIDSTONE.—The carpenters of this town, numbering about 130, have decided to come out on strike to-morrow (Saturday). The question in dispute between the men and their employers is that of overtime. For the first two hours after 6 o'clock p.m. the men, who aim at "scotching" overtime as far as possible, demand time and a quarter, while the masters offer an extra half-penny per hour and after 8 p.m. time and a half. The men are unwilling to accept the offer of the employers on account of the fact that practically all overtime is worked in the first two hours after 6 p.m. Negotiations have been broken off, both sides in the dispute being prepared to face the consequences of the threatened strike, which will probably affect the building trade generally.

MANCHESTER.—A settlement has been arrived at with regard to the demands made by the local operative joiners upon the master builders of the district. At a general meeting of the Manchester and district joiners, held on Thursday in last week, at the Central Hall, Oldham-street, Mr. J. Stewart, chairman of the local committee, presiding, a report was given on the negotiations that had taken place between the committee and the master builders with regard to the alterations proposed by the men in the conditions of working for the district, and the terms submitted by the Manchester Master Builders' Association for a settlement of the questions at issue, were brought up for consideration. The employers' proposals were discussed, and although they scarcely came up to the demands of the men, they were regarded as very reasonable concessions. The chief points on which concessions were offered had reference to increased rates for the first two hours' overtime; increased "lodging" money for country jobs; and better allowances for time occupied by workmen walking to outside jobs. The meeting ultimately decided to accept the offers made by the employers for a settlement of the movement. The notices served by the men were timed to expire on the 30th inst., and in case a general strike had arisen, about 3,000 joiners would have been affected.

NEWPORT, MON.—Although negotiations are going on for a reference of the dispute between the Carpenters' and Joiners' Society at Newport and the Master Builders' Society to the Conciliation Board, the carpenters have decided to form a new society, to be called the Newport Carpenters' Co-operative Society, which will undertake to do work, the society being conducted upon co-operative lines. About 150 carpenters and joiners are idle, and other branches of the building trades are unable to go on with work for lack of joinery. The operative painters have asked for an advance in wages from 7d. to 8d. per hour. The employers have offered the paperhangers 7½d. per hour, refusing any advance to house painters; but the proposal has not been accepted.

PORTSMOUTH.—The six months' notice served upon the Portsmouth Master Builders' Association in November last, asking for an advance in the wages paid to the bricklayers, plasterers, and painters employed in the town, as well as alterations in the working rules, &c., expires on Monday next. The plasterers, through the National Association of Operative Plasterers, are asking for an increase in wages from 8d. to 9d. per hour, with a nine-hours day, and a 10-hours week; the painters, through the Portsmouth branch of the Amalgamated Society of House Decorators and Painters, demand an advance in wages from 6½d. to 7d. per hour, and the constitution of a conciliation board; and the bricklayers are asking for an increase of wages from 8d. to 9d. per hour, and various alterations in the code of rules. The labourers' societies demanded, on behalf of their members, an increase of wages and a new code of rules; but they have offered to accept a compromise.

SWANSEA.—The six months' notice, which the masons gave the master builders whilst demanding an increase in wages of from 8d. to 9d. per hour, expires to-morrow (Saturday). The masters have decided to refuse the demand, and a strike will consequently take place.

## THE BUILDING NEWS

AND ENGINEERING JOURNAL.

VOL. LXXIV.—No. 2261.

FRIDAY, MAY 6, 1898.

## BUILDING DANGERS.

**D**URING the last few months several fatal building disasters have taken place, some of them attended with serious loss of life. Two or three have been reported from America. One of these, at London, Ontario, we very recently described. A public meeting was being held in an upper floor, when it gave way under the weight and stamping of the people, and in its fall carried with it another floor, killing several and injuring many others. The cause of the failure was not satisfactorily determined; but there is little doubt that the beam at the end of the room which gave way was either unsound, or the pieces composing it were not securely bolted together. Soon afterwards we recorded a collapse of a new roof over another large assembly-room in Canada, which might have resulted in equally serious consequences.

The sad crane catastrophe at the Waverley Station, Edinburgh, which resulted in the death of three workmen and the injury of 15 others, is too recent to be forgotten. The failure and collapse of speculative builders' work is frequent in the Metropolis; but these failures often arise from inferior materials, bad mortar, and rapid building, and are amenable to stricter regulations and supervision. But what are we to say of the collapse of buildings in which well-considered construction and skilled supervision have been employed? When a building of superior construction gives way from a sudden fall of a floor or roof, and yields, in fact, under the weight of the sudden impact of its materials, we naturally ask what are the limits of the strength of the structure or of its component parts? When the fall of one floor causes the giving way of the other floors, as in the case of a house built with cards, there is a certain degree of unreliability that suggests a very small margin of strength. At the present time it is a remote inference to draw any conclusions between stability and safety and external appearance. Our external façades represent solidity and strength, there is nothing to suggest a thin wall or a weak floor in the details exposed to view—indeed, the art of disguising is so complete, what with casing our girders and iron columns, that it is impossible to say from external appearances whether a building is substantial or flimsy.

The serious catastrophe we reported last week of the collapse of a new building in Orchard-street, Westminster, through which seven lives were lost and several injured, is an example which we may well take to heart. Till the investigations of the experts commissioned by the Home Office have been concluded, and the report made public, it is premature to offer any opinion, though it is rather a difficult task for the most experienced to discover from so much fallen *débris* the cause of the disaster. If, as supposed, the catastrophe was caused by the collapse of the concrete roof by the removal of the supports before the concrete had proper time to set, no one can be blamed except those who may have given orders for the removal, or unauthorised removal. The circumstances, apart from the particular building or fault to be attached to anyone, are instructive. Many labourers engaged in this kind of work are ignorant of the nature of concrete, and we have heard of instances where the workmen have, on their own responsibility, taken away centres, believing the concrete or the arch,

as the case may be, was properly set. The coroner intimated that the Building Act itself may be defective in permitting "a building to have been put up within the ordinary legal limits, and yet to collapse in the way this had done"; but the Act does not pretend to instruct builders or workmen in the operations of work as to striking centres, or as to the time to wait before concrete can set. It would indeed be well, and on the safe side, if the Act included a regulation requiring that no supports or "centres" should be removed before an examination by an official had been made. The building in question, which we illustrated on April 22, is a large and handsome corner building, "Abbey Mansions," for H.M. Office of Works, Victoria-street. It is of eight stories in height, and has been erected at a considerable cost. We understand there were a number of sub-contractors employed. When an accident befalls a building of this kind, we may well ask what buildings can be pronounced free from danger, under certain conditions. There have been other cases of the fall of one floor carrying with it the lower ones—a fact which makes it more incumbent upon builders or foremen to use the greatest caution in the supervision of those engaged in the upper portion of a building. Have we not heard of heavy iron roofs collapsing and carrying with them the floors below, owing to a want of care in screwing up the nuts at the ends of tie-rods, while the whole weight might have been safely carried by timbering or shores transmitting it to the floor or walls below? The suddenness of the impact, or the measured tread or stampede of a crowd, adds immensely to the destructive effect of the load. The conditions of modern building in towns call for more than ordinary precautions. Owing to the rapidity with which buildings are run up, the vicissitudes of contracting, the use of green materials and bad mortar, the complication of new building expedients, faulty ironwork, and other causes, new buildings are quite as much, if not more, liable to accidents as old and dilapidated structures, for which the Dangerous and Neglected Structures provisions of the London Building Act have been framed. It is needless to recall the number of "jerry" buildings, the walls of which, through inferior and green materials, have given way without timely warning, or the defective iron girders and columns which collapse and cause fatal injuries. These are some of the contingencies to which new buildings are exposed, and which demand more careful supervision by the local authorities.

## ARCHITECTURE AT THE ROYAL ACADEMY.—II.

**T**HERE is always something inscrutable about the selection year by year of drawings for the Architectural room of the Royal Academy, and the exhibition consequently is, as usual, replete in surprises. For example, one exhibitor, Mr. Baillie Scott, last year sent several very original studies, but they were all rejected. He sends the same subjects this year, and they are hung. This is by no means uncommon. Indeed, many of the most interesting exhibits of 1898 were refused in 1897. Another of the most curious features about the collection this year is the preference which the hanging committee has accorded to small projects and mere designs, the choice of which has resulted in a fringe of inconsequential frames disposed below larger drawings along the top of the skirting, patchworked in where they best might be made to fit—puzzle-wise. Some of these trifling oddities, too, appear to have gained selection mainly on account of their indescribable queerness in draughtsmanship: witness Nos. 1630 and 1636—two frames in body colour of fancy designs for "An Artist's

House," by Mr. A. H. Skipworth. If these two schemes were worth showing at all, surely the author should have been expected to set them forth in a more workmanlike way. Mr. C. R. Ashbee is another artist who revels in the ecstasy of eccentricity, and so in 1683, Wombourne, Wodehouse, Wolverhampton, we not only have a triplet of W's, but a strangely uncouth façade baldly delineated, in a weak weary way, with an outline block plan awkwardly contrived on the sheet to fit in flag-like form over the gablet in the centre of the composition. The design is for a house, seemingly, displayed with shaped gables and windows so high up in the dormers as to finish inside hard up against the soffit of the rafters. Emancipated from ordinary considerations, the proposal as here feebly shown, looks amateurish to a degree, and it is not pretty either. Its faults are cultured, however, and the drawing may possibly serve as a corrective to the over-elaboration of professional draughtsmanship. This, perhaps, was the reason for hanging this elevation. But we can conceive no possible good derivable from the inclusion of such an extraordinary exhibit as No. 1657, Town's Green Memorial Cross and Drinking Fountain, Chorley, by L. Rycroft Oakes. One more example of this foolishness of selection. Let any impartial and qualified architect look at No. 1596, an outline proposal for a new church at Barnoldswick, by Messrs. Bromet and Thorman. Observe the west window, the buttresses, the turrets of the tower, and the arches which span the intervening spaces! If the members of the hanging committee who thought this worthy of the space they gave it care to know what we do consider deserving of a position in the Academy as a church design, we have no hesitation in naming one. It shall be the proposal for a South London Church, by Mr. C. A. Nicholson (Nos. 1696 and 1700), to be built on a triangular site. The scheme is unusual, with two naves, and an aisle wedged in between. The choir is cut off boldly from the body of the church, and the pulpit is located next the central pier at the end of the aforementioned aisle. German fashion, there is a second altar at the "west" end of the church, and this altar faces the pulpit. Outside, the walls are of brick; inside the arcade in plaster, unrelieved by mouldings, and springing from plainly-built stone piers. The choir organ is situated in a sort of triforium at the east end of one nave. The whole thing is uncommon and unconventional to a degree. We should be glad to see it built.

The late Mr. Scott, of Brighton, was the architect of a big barn of a church in stock brick, which was erected about thirty years since on a site near the Lewes Road by the Rev. Arthur Wagner, the vicar of St. Paul's in West-street. The building, which is of vast height, was dedicated to St. Bartholomew. Mr. H. Wilson has now made a design for a baldacchino, and he is, it would seem, rearranging the chancel. We have no doubt whatever but that he is doing this with good taste; but no one can really tell exactly how it is being accomplished if they only have the vastly-too-big charcoal drawing shown this year (1711) at the Academy to go by. The drawing is hung out of the centre of the gallery, and being placed high on the wall, heavy dark mass that it is, the effect is disconcerting and crushing in scale. The ordinary exhibits displayed anywhere near it are spoiled by its selfish weight. It is not necessary in condemning the size and shimmer of this cartoon to imply that Mr. H. Wilson's designs are not admirable—indeed, one has only to examine his bronze and enamel "Tabernacle" (1949) in the lecture-theatre among the sculptures, to judge how thoroughly clever Mr. Wilson is; but we consider it an injustice to others that so much room should be given to a

comparatively unimportant performance deliberately set forth in this scenic and sensational fashion, at once vague and ineffective, as a study of architecture, its attraction being mainly due to its inordinate scale.

Mr. J. J. Stevenson, hitherto unknown as an ecclesiastical architect, sends a flatly-handled water-colour, of somewhat pleasing simplicity, of a Free Church at Kelvin, Glasgow. The perspective looks more like a developed elevation. The tower has a regular Scotch crown spire of buttresses after the types at Old St. Machar's, Aberdeen, and St. Giles', Edinburgh. The traceried windows seem studied on old national churches, with the historic touch of Flamboyant design introduced. St. Patrick's Church, Dundee, with Presbytery, by Mr. T. Martin Cappon, is much more free in treatment, with a squat belfry stage to the square-built tower, an octagonal lantern appearing above as a crowning feature executed in timber. Another Roman Catholic church deserving of special notice is St. Augustine's at Nottingham, by Mr. Arthur Marshall (1669), designed in brick, very cleverly contrived for a restricted site at the corner of two streets, a great feature being made of some flying buttresses over a narrow aisle. Between there are big traceried windows. The lead flat roof over the aisle is a questionable device, however. Mr. Charles E. Ponting is represented by a small hillside church dedicated to St. John the Divine at Ford, Wilts, very picturesquely delineated, with some cottages and an old bridge in the foreground (1686), an interior (1652) being given to show what effective work can be done in good taste with limited means. Mr. A. Skipworth shows a curious design for a rood-screen at All Saints, Fulham, in a German-like Gothic style, with a cambered beam surmounted by a range of candlesticks. The traceries below look wiry and thin; but this exhibitor always shows a degree of freshness which we welcome, even if we cannot always admire his conceits. One of these is the incorporation of a pulpit in a screen for Udimore Church, Sussex (1776), where, to make the balance of the composition true, a sort of cupboard inclosure is contrived on the south side of the screen. Had a loft over the screen been included, a stairway might have justified the treatment, but at present the effect is meaningless, and in the drawing the design looks very like a fireplace. Mr. James Brooks has made far more worthy designs than St. Luke's, Enfield (1716), with its somewhat regulation type of tower and thin-timbered treated gables to the quasi-transsepts. When we judge this veteran's designs we remember his East-end churches, which have never in their way been surpassed, so that we miss the sweetness of good proportion in looking at the shape of the lancet fenestration at the end of this one. Mr. J. O. Scott sends the richly managed tower of St. Mark's, Harrogate (1719), worked out in correct accord with traditional spirit. Another tower of massive proportions is Mr. W. D. Caröe's design for St. Michael's, Woolwich (1706). Mr. Percy G. Stone exhibits a section showing the new timber roof and screen for St. Peter's church, Shorwell, Isle of Wight, at once suitable and inspired by a close study of local Mediæval work (1737). The marginal drawings illustrate this architect's love of Gothic grotesque in carvings. They are here depicted with feeling and ability. Messrs. Clark and Moscrop are represented by St. Luke's Church, Darlington (1803), a pleasant-looking group of buildings; and Messrs. Rogers, Bone, and Coles evince a quaintness by an Arts and Crafts manner in designing the choir fittings for St. Brelade's Church, Jersey (1661), which are fashioned in a sort of domestic way not surely out of place, however, in a country church. St. Luke's Chapel, West Hampstead (1655), by Mr. Basil Champneys, is the subject of an

unambitious drawing, showing, of course, good work; but this architect does himself an injustice by exhibiting such a weakly-executed elevation (1757) of the Robinson Memorial Tower at New College, Oxford. The Higher Grade School, Scarborough, by Messrs. Hall, Cooper, and Davis, is picturesque enough, and deserved a better place on the walls (1754).

Turning now to some of the street architecture shown in the exhibition, we may briefly record some notes which figure in our copy of the catalogue, and not before transcribed. The first is Mr. J. M. Brydon's Art Galleries at Bath, a work quite in harmony with the old vernacular Classic of that city (1625). Mr. Walter Cave's small green brick front, 40, James-street, S.W. (1634), has a pleasing plaster bay and a stone gable—a nice notion neatly carried out. Mr. Ernest Newton's street row of buildings—including a bank, an hotel, and some shops at Bromley (1638), has the advantage of good drawing, and illustrates a capability on the part of the architect which is beyond question. The bank, however, hardly bespeaks itself, and the ground-floor front looks more like a place for light refreshments or perhaps the well-lighted hall of a private house. The shop-front adjoining is very ordinary. The George and Dragon Inn, Castleton (1667), is a characteristic minor work, the production of Mr. Edgar Wood. Another roadside inn of good style is one at Bromford (1684), by Mr. H. T. Buckland. The Public Baths at Bethnal Green (1703), by Mr. R. Stephen Ayling were won in competition, and well deserved their choice. Messrs. Bateman and Bateman send a competition design for Bury Free Library (1717), and Mr. Sidney Smith shows a large red house in Green-street, Park-lane (1726). The Public Library at Shoreditch, by Mr. H. T. Hare (1728), is one of the most satisfactory buildings of its class in the exhibition, skilfully conceived, and well worked out. Mr. Davison's drawing does it justice too. The Bank, Blyth, Northumberland, by Messrs. Armstrong and Knowles, hangs near (1732), and close by is a florid gable designed for Clerkenwell Town Hall, of which Mr. C. E. Vaughan was the architect (1753).

The rebuilding of Gosling's Bank, Fleet-street, by Mr. Arthur C. Blomfield, will make an important addition to the architecture of Fleet-street (1750), and we herewith illustrate Mr. Paul's capable perspective by which the façade is represented at the Academy. The plan is contrived with every regard to the purpose of the building, and the exterior is at once dignified and refined. Mr. Field has an important block of General Office buildings for the North Eastern Railway Company at York, of which an admirable view is given by 1780. The whole group is spiritedly picturesque with ample windows, and a business-like air about it, showing what can be done to inspire commercial premises with rather more than a degree of interest.

Turning, in conclusion, to some of the hitherto unmentioned country houses, we note a red-brick Classic mansion by Mr. Reginald Blomfield at Medmenham, rather carelessly drawn, with windows out of the upright (1786), but like all this gentleman's work, somewhat dashing in style. (We cannot pass on without giving warm praise to his design, hanging near his other exhibit, for the Processional Crucifix for St. Paul's Cathedral. It is a very capable and well-studied proposal.) The Cottage Homes at Mill Hill (illustrated by us this week) for the Linen and Woollen Drapers' Institution, by Mr. Geo. Hornblower, are shown (1796) in a crisply-executed bird's-eye view, to be a pleasingly grouped set of comfortable buildings. "Cliff Towers," a Colonial home designed by Mr. Harrison Townsend (1771), is seemingly a shingled dwelling, cleverly treated. Mr. C. F. A. Voysey has two of his smaller

houses—one in Surrey and another in Hampshire (1758, 1759), represented by the skilful brush of Mr. Howard Gye. Both residences are in plastered walling, ingeniously contrived in a thoroughly country-side way, homelike and quaint. Highcombe Edge, Hindhead, by Mr. William A. Pite, has some uncommonly good interior woodwork about it, and the sketches in the hall (1730) are, therefore, interesting. The Old White House, Oxford, by Mr. H. T. Hare, we notice with satisfaction (1725), and hanging close to it are some views in pastel, by Mr. Rickards, of Mr. Leonard Stokes' ingeniously-designed House at Pangbourne, overlooking the river (1720 to 1724). The picture gallery, as well as the exteriors, show much ability. Houghton Grange, near Huntingdon, is by Mr. J. Ransome, and Mr. F. S. Taylor has a Waterside Hotel from the Isle of Wight, both worth naming (1695 and 1693). The Red House, Ayr, by Mr. J. A. Morris, is seen in a good pen view with large bays to the mansion overlooking some formal gardens suitably managed (1692). Braham, near Perth, is another Scotch house. The architect is Mr. F. W. Bedford, and his work is of sterling character (1680). The same unambitious merit is observable in "The Court House," Broadway, Worcestershire, by Messrs. Guy Dawber and Whitwell (1677), who have worked their designs entirely in accord with the old stone buildings of that county. Mr. J. H. Smith has a timber house of pleasing character, called "Summerdale," Epsom (1665), not long since illustrated in our pages. Mr. Alex. Cullen sends the staircase of "The Ross," Hamilton, N.B. (1662), designed in a Jacobean style at home in Scotland. Rotherfield Hall, by Mr. Inigo Thomas, should be noted (1649) for quaintness tastefully thought out, and the same praise is due to Messrs. Bateman's plastered house at Edgbaston (1644), with the red brick chimneys. Mr. Halsey Ricardo is very restrained in his conceptions of fitness. The rigid severity of his house at Bramley is simplicity itself (1640). Mr. E. Newton is also commendably plain in his brick house at Wokingham (1637), which is cleverly drawn in colour, a little overdone in finish. Mr. Collutt's own house, "The Croft," Totteridge, we are glad to see hung (1615), as it well merits a place on the line. We illustrated this view, and the garden front also, on August 14th, 1896. Mr. Ernest Runtz has a clever little house (1612) at Sutton, which we shall soon illustrate, and Mr. E. J. May shows some good sketches by the same hand of some capable additions to an ungainly old house, Jardine Hall, Dumfries.

## PICTURES AT THE ROYAL ACADEMY.

[SECOND NOTICE.]

ONE of the most charming landscapes in the first gallery is Gilbert Foster's "Whispering Eve" (21), a landscape or hillside under widespreading trees, the grass slope covered with daffodils. We have seen nothing better of this painter's work. There is a delightful atmosphere as one sees in spring: deep recesses of woodland lend beauty and mystery to the scene, fading into a blue hilly distance beyond. A grand seascape by Edmund G. Fuller, "A Fair Wind" (11), is a fine stretch of blue sea; the reflection of the sky is well painted. We have spoken of H. W. B. Davis's large sunny picture, "A June Evening," the apple-blossom and cattle in which are rendered with his consummate skill. Last week we briefly noticed Briton Riviere's great work, "The Temptation in the Wilderness" (22), a grand solitude. The painter has impressed the spectator with the majesty of this desolate mountain summit, upon which sits, with bowed head, the white-robed Man of



Sorrows. The undulating surface of the vast rocky plateau resembles a dark tumultuous sea, the bright horizon being reflected on it. H. H. La Thangue's "Night-fall," an old peasant woman and her daughter making their way homeward through a narrow path with their gleanings in the pale moonlight, is a fine piece of realism with a certain pathetic interest. The grouping of the bending figures and the colour in his "Bracken" (123) in the next gallery—an old woman who leads the way laden with bracken, followed by another younger woman, in a warm evening sunlight—are also admirable. "Good-bye, Holland," a group of Dutch fisherfolk on the beach waving their farewells to a small sailing vessel that is leaving the shore, is charming in colour, and pathetic. Passing a few good pictures by Norman Garstin, Alfred Parsons, Horace H. Cauty, and a few others, we come to J. W. Waterhouse's very graceful and somewhat Mediaeval conception of "Flora and the Zephyrs" (64), a further examination of which confirms our first impression of its merit. The scene is laid in a garden or mead. From the foliage of trees the zephyrs are ministering to the goddess, who is seated. One places a white-rose garland round Flora; other nymph-like figures, clad in thin draperies, are picking wild roses and anemones. The goddess herself is robed in a figured dress of violet hue—all in pleasing harmony with the grass and flowers. The painting "Ariadne," in the Third Gallery, may be compared to it in surroundings, grace of figure, and melodious colour. The beloved of Theseus reclines asleep on a couch in a walled-in garden, her scarlet drapery, or peplos, open at the bosom; underneath the couch a panther is asleep, and another is just crouching to him. The harbour and galleon and sunset cliffs make up a pleasing composition. The conception is certainly poetical, the colour of tertiary hues soft and harmonious. But to pass to J. C. Hook's "Idlers," a delicious piece of coast scenery, a limpid and fresh sea breaking upon a sandy beach; a distant headland is seen on the left. The title is given to the least-prominent object—the idlers on the shore.

"Unconverted" (76), by E. D. Millet, is, as usual with the painter, a subject of quiet humour. The picture is a softly-lighted interior of a country inn, in which, near a table, a black-dressed young Puritan preacher with Bible in hand, wearing a large collar, stands. He turns his head disdainfully to a couple of maids who are engaged in peeling apples, one of whom offers him an apple smilingly. Seated on the table another customer is laughing quietly at the joke. The solemn demeanour of the young evangelist, and his contemptuous look at the girls who are offering him an apple, is amusing, and is painted in that pleasing cool tone of colour that we usually see in Mr. Millet's work. Alfred Waterhouse, R.A., sends a clever picture of "Arisaig, N.B." Seymour Lucas has a charming piece of colour in his "Phyllis is my only Joy," a lady at piano, a gentleman accompanying her on the mandolin, against tapestry background. Our passing notice of Mr. Abbey's great picture "King Lear" was brief and imperfect; we now, in a little more detail, examine the composition. Mr. Abbey's brilliant pictures from Shakespeare, his "Richard III." and "Hamlet," are already well known; this one of "King Lear" is a worthy successor. The subject is taken from the first Act, where the fair and portionless Cordelia is accepted by the King of France, who is reverently kissing her hand. She is about to depart. She is taking farewell of her scornful sisters, and speaks those words, half in reproof, half in irony—

"Ye jewels of our father, with washed eyes  
Cordelia leaves you."

They stand reproved, but take the words in scorn. One, in a crimson robe, rises from

her seat and half-mockingly raises her skirt with both hands. There is a suppressed smile on her face; the other sister, more demure, dressed in black, draws her robe close round her; but the central and most beautiful figure is that of Cordelia, in pale lemon drapery, her fair plaited hair falling over it. She turns in sweet reproof to her sister, her left-hand she permits her Royal lover, to kiss. On the right hand side the old King and Court are leaving; the King, in white robe and long white locks, shambles away, with the fool at his side, followed by his faithful dog. There is something very pathetic in this farewell of Cordelia, and Mr. Abbey has painted the scene with much majesty, and without any stagy effect. The poet, rather than the mere dramatist, has been studied. There is a sweetness in the look of the central fair figure of Cordelia to which all else is subordinated; the young French King wearing his crown forms one of the background figures, and the two other sisters are in rich but subdued tones. A barbaric splendour pervades the surroundings, especially on the retreating procession followed by King Lear. The costumes and colours are rich and harmonious. Frederic S. Richardson's "Katwijk Dunes" is a delightful piece of colour, a sea-shore, fresh and full of atmosphere and light. Mr. Frederick Goodall's picture, "A Gilded Cage" (167), a seraglio or divan, in which a lady in orange skirt reclines on a cushioned seat, and is about to relieve the tedium of her existence by a pipe which is being lighted by a slave boy, while a dusky attendant is bringing in a tray of liqueur or dainties, is somewhat hard.

In the next Gallery, III., Hubert Herkomer's large upright canvas "The Guards' Cheer: Crimean Veterans of the Guards cheering her Majesty during the Jubilee Procession," has a popular interest, and the painter has achieved a higher success in this than in his other portrait subject. As a background to the old Guards in scarlet uniforms is the Guards' Memorial, a monument whose bronzy darkness forms an admirable foil to the scarlet; but there is a mobility of feature in the faces and lips of the old men as they raise the cheer, and a variety of expression that is almost touching. The grouping and colour are strong and happily harmonised.

The President's "Duchess of Somerset," in a dress as Lady Jane Seymour (179), which the duchess wore at the recent Devonshire House ball, is Holbeinesque in beauty and accuracy of costume. The splendid jewelled dress of brocaded silk and of golden hue, the jewelled coif, the pendant, rich in pearls and rubies, and the jewel-bedecked skirt and head-dress, make a very rich and historical portrait. The President's subject picture, "The Skirt Dance," is another version of a similar theme we have seen before. A closer examination only makes more evident the technical skill of the painter of the Classic interior, the translucent marble, and the splendour of Classical draperies and flowers. The dance which the girl is performing is what is known as the "Ionic Movement"; but the work is academical, lacking in human interest. With all its beauty of drawing and technique, there is something unsympathetic, and a little hard and unyielding. The very exquisiteness of the many-coloured marble floor, and the finish of the accessories make it almost impossible to expect any feeling. The sitting maidens look on and chat unconcerned at the graceful movement of the *dansusee* before them.

We glanced at the splendid landscape of B. W. Leader, "In a Welsh Valley," and "Where Peaceful Waters Glide" (309), and "The Silver Sea" in the next Gallery, which alone entitle him to the honour he has lately won in the Academy. We see the perfection of finished landscape, serene

calmness, unclouded skies, translucent water or rippled sea reflecting the beauty of hill and sky. A golden sunlight gilds the hill-tops of the Welsh mountains in the first, while in the last named a cool, silvery light pervades the atmosphere. The realisation of nature is in the hands of Mr. Leader only to be attained by great care and finish; but we never find his work suffer, as in many cases it does, by this kind of regard for detail: breadth and effect are seldom lost.

G. H. Boughton's chief work, "The Road to Camelot," briefly noticed already, does not give us the impression of a mirrored image of the passing world outside. There is little suggestive of the magic mirror, or of the romantic and tragical circumstances recorded in "The Lady of Shalott," but the scene is bright. We pass on to notice W. Q. Orchardson's delicate and fascinating portrait of "Miss Fairfax Rhodes." The lady is in a pale blue or grey dress, and has a pleasing and expressive face, but the light scheme of colour, like a delicate sketch, is the chief merit. His portrait of the Rt. Hon. Viscount Peel (330), a study of side face, is characteristic of the sitter, whose closed eyes and expression indicate a mental reserve. The painter has obviously observed his subject through a Parliamentary debate; it is not a portrait of repose—rather of one suitable to go with others of illustrious Speakers. In his subject portrait "Trouble" we can add little to our former description. What the trouble is is not clear; perhaps the young lady in evening dress, who is turning round to look at the dejected lover or husband, is the cause. At all events, we admire the elegance of the figure, the "Empire" drawing-room, its warm flood of golden hue. The subject is not so great a success as his former, "A Rift within the Lute." Andrew C. Gow's "A Gentleman of the Road" is a cleverly told incident. On the distant roadway, on a bleak and desolate heath or common, a coach and its occupants have been waylaid; a scarlet-coated individual is being attended to by his companions, while on the road lie scattered a number of letters. The mail-coach has been stopped and plundered, and the masked highwayman on horseback is beating a retreat, making a short cut across the common. Near it Ernest Crofts sends one of his historical pictures, "Charles II. at White-ladies after the Battle of Worcester." The King and his retinue are shown making a halt in the courtyard of a large hall, after their defeat by Cromwell at Worcester. Mr. Crofts has lost none of his vivacity of touch, romantic air, or scholarly precision of detail. The two coast scenes by J. C. Hook, which hang on each side of Frank Dicksee's rich Renaissance study of lovers, are not quite so interesting. "Trouble with the Muzzle-loader" is the somewhat irrelevant title of a rocky creek, painted with Mr. Hook's inimitable skill as a delineator of coast, in the foreground of which a man is examining his gun. A number of rabbits lie before him on the grassy bank, and his dog. No. 278 is a more pleasant coast view, a distant line of cliffs forming a bay with the foreground, with a fresh breezy sea, and anchored boats on the beach. In Marcus Stone's "A Welcome Footstep" we have one of the well-known garden scenes, a white-frocked young maiden at her worktable with ribbons and wool, while beyond is seen the figure of her lover just coming through a wicket gate. As a pretty piece of sentiment, this picture hardly ranks with other subjects by the painter. It is a little stale; but it is a profitable subject for engravers. Val C. Prinsep's picture, "A Student of Necromancy" (283), has a deeper meaning. A darkened chamber in which a sombre-robed student is examining a ball of crystal. On a stool burns a flame from a basin. On a richly-carved coffer or sideboard which forms the background is a skull, and a

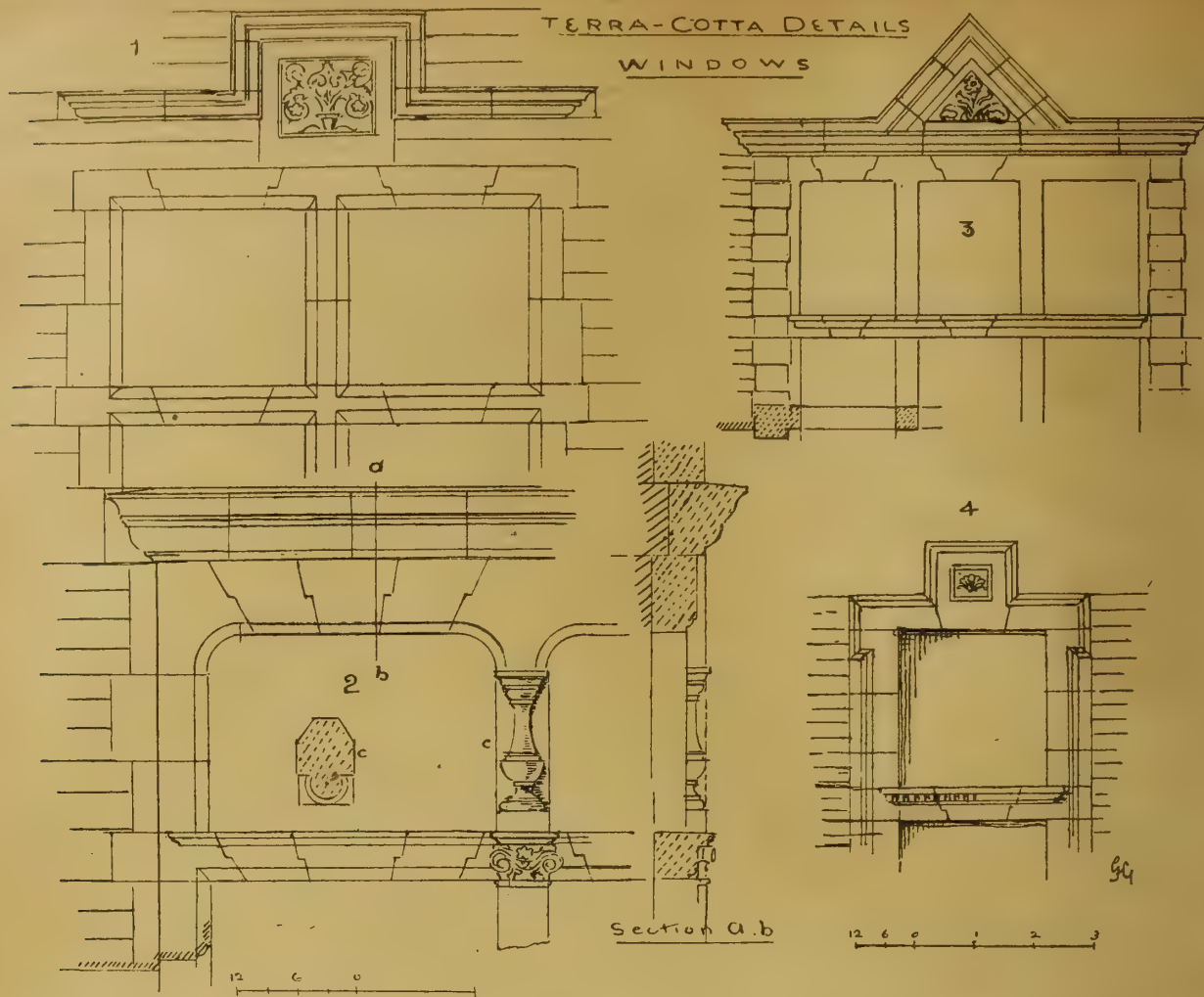

bookstand on which is a large volume of occult science. There is an air of mystery in the conception, and the solid painting contrasts with other everyday subjects.

G. F. Watts sends only one composition, and this a large upright allegorical picture "Love Triumphant" (310). Love is represented as a winged youth, with outstretched arms extended to heaven, standing on a rocky summit. On each side of his feet lie the dead bodies of Time and Death. The composition is majestic and powerful as an ideal conception, and may be compared in its handling and richness of colour to "Love and Death." Over it a light and brilliant decorative picture is hung, by T. Austen Brown, "La Benediction de la Mer: à Etaples"—a procession, with banners, of young girls in white, trimmed with blue, wearing wreaths of flowers, by the sea. A bishop in crimson cassock, wearing his mitre and holding his crosier, is giving his benediction, while beside him stands the cross-bearer. The key of the colour is in marked contrast with Mr. Watts's visionary picture.

Herbert A. Oliver's "In Fields Elysian" (305) is a poetical conception of "blinded Death" scythe in hand, stealing about in a field covered with scarlet poppies; a picture showing undoubted power. Another very noble and harmonious portrait by W. Q. Orchardson is "Mrs. Pattison," an elderly lady in black, seated in a red chair. Alfred Parsons' large landscape "The Mooters, Bishopswood, Herefordshire," and one of the best in the Academy, is a grand subject, masterful in its handling and colour. On a hill-top men are busy burning wood, and uprooted trees lie on the brow. Beyond, a distant prospect opens to view before the spectator. Byam Shaw's eccentric allegory, "Truth," is a conception of the same class which he

gave us a year or two ago, and illustrates the verse—

"Of Truth doth here this truth appear,  
Withouten al disgyse,  
How men do stryve wych are y-lyve  
To shutte her from their eyes."

There is a quaint Mediæval symbolism in this work. "Truth" is a blindfolded nude maiden in the presence of a king and his court. Behind, three ladies are holding up a green velvet drapery as if to conceal her figure, while in front is a large bowl filled with a thick scarlet liquid like blood, in which a jester is dipping a white linen cloth. Other figures crowd the canvas, their eyes turned away from the central figure of Truth. The moral is clear. The innocent and truthful maiden is to be clothed or disguised by a decorous garment. Stanhope A. Forbes's picture, "The Letter" (365), is a group of cottagers at their door at night-time. The country postman, laden with bags and parcels, stands to examine his letters. The candle-light illumines the faces of the group at the door, casting blue shadows, and it is this part of the picture which is so realistic, and recalls other work of the painter where artificial light is represented, as in his last year's "Christmas Eve."

#### MODEL SPECIFICATIONS.—XI.

TERRACOTTA—(continued).

THE sizes of blocks and the jointing of terracotta work are important matters upon which the proper treatment of this material largely depends. The frequency of joints varies much in buildings. In some of them we find the blocks are comparatively large, in others small, and no doubt much of this difference depends on the clay and the degree of shrinkage in burning. We may give as examples of brick and terracotta

work in London, the Prudential Offices, Holborn, and the Buildings in Carey-street; also the Natural History Museum, by Mr. Alfred Waterhouse, R.A., the blocks of offices in Arundel-street and Surrey-street, the recent corner block of offices and shops in Wellington-street, Strand, and offices, shops, and residences in Bond-street and Oxford-street. These are important and easily accessible buildings.

Other good examples of the employment of terracotta work may be found at the Northampton Institute, Clerkenwell, by Mr. E. W. Mountford, the Empire Theatre, Cambridge Circus, by Mr. T. C. Colcutt, and houses at Chelsea, Cadogan-square, and Collingham-gardens, by Messrs. Ernest George and Peto. These buildings will suffice to show the varying kinds of jointing and the sizes of the blocks employed. The Birmingham Law Courts, by Messrs. Aston Webb and E. Ingress Bell, the terracotta for which was supplied by J. C. Edwards, Ruabon, is a successful instance.

Our sketches are intended to illustrate different types of window-heads, in which the joints are joggled, and the mode of treating mullions and transoms. Fig. 2 shows a two-light window with centre mullion and transom. The head and transom have joggled pieces, and the jambs of window bond into and course with the brickwork. Figs. 3 and 4 are other examples. The details on the opposite page are taken from an executed building, and we give clauses to describe the work.

We here subjoin clauses for a front in terracotta that would be suitable to houses of the kind we see in Cadogan-square or other West-end suburbs, and in which an ornamental gable like that we gave in our last issue, p. 591, is introduced.

## TERRA-COTTA DETAILS

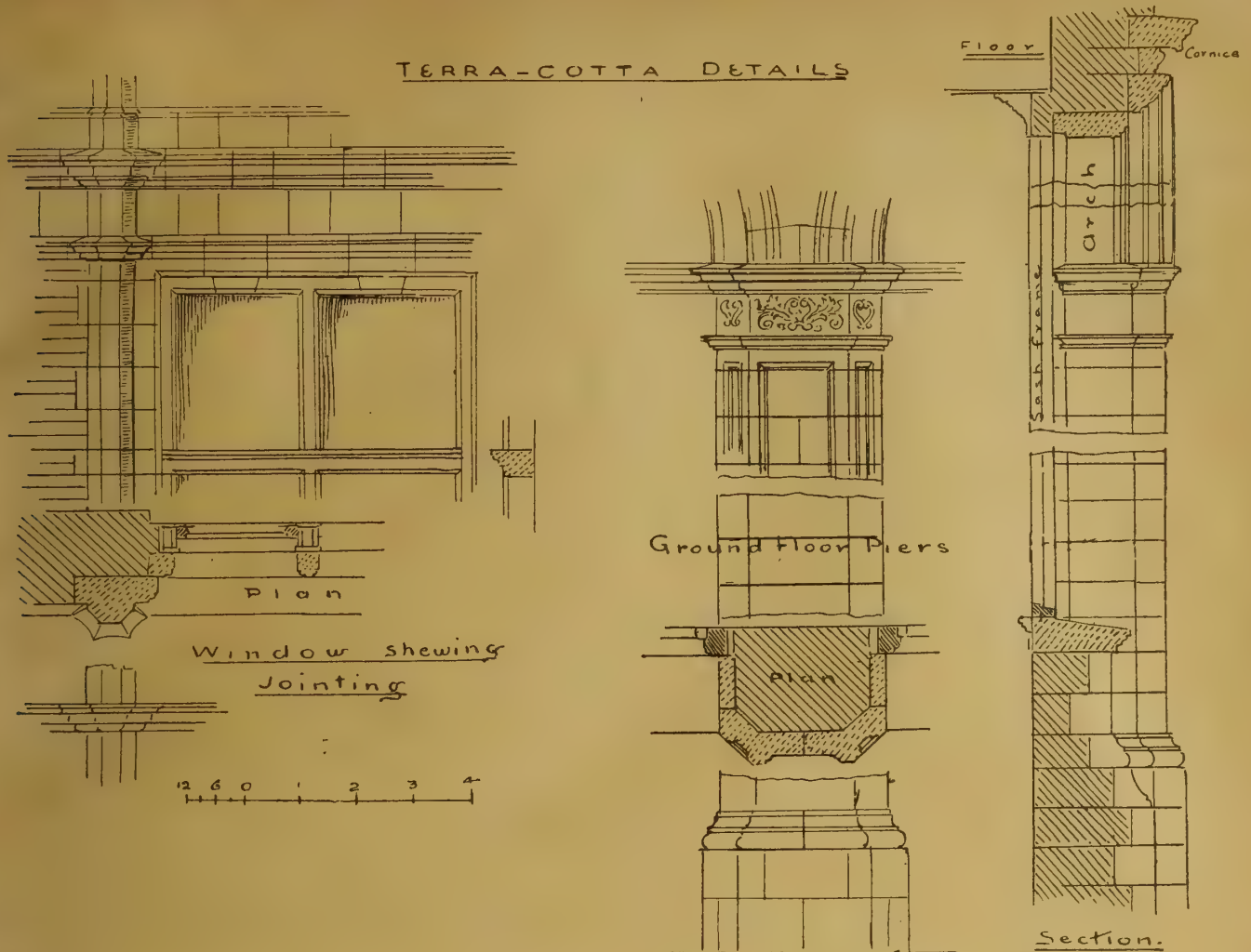

1. *Facings*.—The facing-blocks of terracotta are to be well-burnt red (or buff, of approved colour), and of tones approved by the architect (or uniform in colour), and to be supplied by Messrs. Doulton and Co. (or by J. C. Edwards, Ruabon), and where the blocks are large, are to be chamfered, no part being less than 2in. thick. The hollows to be filled in solid with fine lime concrete, in the proportions described, the blocks being well soaked in water before filling. The courses of terracotta to be 9in. and 6in. (or 12in. and 9in.) in height or depth, to bond with the brick backing alternately, or as desired, and no piece to be longer than 18in. The original surfaces or edges of the pieces are to be left as they come from the kiln, and are on no account to be chipped or filed, unless the parts so treated are hidden.

The blocks to be set in fine mortar of approved proportions, neatly pointed with a bevelled joint as the work proceeds, no joint to exceed  $\frac{3}{8}$ in. ( $\frac{1}{2}$ in.) in thickness. The blocks are to be  $4\frac{1}{2}$  (or 6) and 9in. in thickness, to form a good bond with the brick backing. The whole facing to be cleaned down at completion, and all the horizontal and vertical arrises to be true and regular.

2. *Doorways*.—The jambs of entrance to have fluted pilasters (or mouldings) of terracotta in accordance with the detail drawing supplied, jointed as shown, or, if hollow, filled with fine concrete in the proportion of 1 part by measure of Portland (or Roman cement), 2 of sand, and 4 of fine clean ballast, the stones to pass through an inch ring. Each piece of terracotta to be thoroughly soaked with water before filling the hollow, and the pieces to be thoroughly bonded with the brickwork and flushed in with mortar. The base and capital (if any) are to be of the profile shown in full-size section, the arrises and mouldings to be true in line and regular when fixed, but no chipping or filing of the original surfaces or angles will be allowed. Or, the capitals of the pilasters or columns to be cast in one or two pieces, as shown, and to be filled in with concrete as described.

The arch mouldings to be in accordance with detail, and to be carefully set out before modelling with the assistance of the contractor (or clerk of works), the joints or voussoirs being as shown, with keystones according to detail supplied, (or selected from Doulton and Co.'s or J. C. Edwards's catalogue); and the ornamental spandrels or frieze to be No. — in J. C. Edwards's

(or Doulton and Co.'s) catalogue, carefully modelled. The whole to be set in fine mortar, and pointed as the work proceeds, cleaned down at completion, and left to the architect's satisfaction (or to be set in mortar to match the facings).

3. *Bay Windows*.—The bay windows to be constructed of terracotta according to working drawings; the mullions and transoms to be  $4\frac{1}{2}$ in. by 6in. (or 6in. by 9in.), jointed as shown; the lintels, heads, and transoms to have radiating or joggled joints. The entablatures or cornices to be of hollow blocks not longer than 12in., and to be jointed, as shown, with close, neat joints; the mouldings to be true in line, and no piece to be chipped or rubbed, the whole to be set in fine cement (or mortar) coloured to match the facing, and to be neatly pointed with joints not to exceed  $\frac{1}{4}$ in. in thickness. Carefully clean up, and straighten the terracotta where next to the joinery.

4. *Other Windows*.—The other windows to be executed with terracotta architraves or jamb mouldings, bonded into brickwork and mullions, with cornices and pedimental heads as shown in details (see sketches, p. 590, and those here give 1, 2, 3, and 4, or on opposite page), and in all respects according to previous description.

5. *Ornamental Panels*.—The ornamental panels (if any) below the ground-floor windows, in the pediments or above heads, to be modelled according to the drawing and to the architect's satisfaction, and to be cast in blocks of not greater size than shown or directed (or the ornamental panels to be those No. — in J. C. Edwards's Catalogue of Patterns or figured in Doulton and Co.'s "Architectural Terracotta"), and the pieces to be well bonded with brickwork and flushed in with mortar.

6. *Cornice, &c.*—The main cornice and frieze (if any) to be of well-burnt hollow blocks of terracotta in one or two courses 12in., 9in. high and 9in. and 6in. deep, and not more than 15in. long, to be well tailed or pinned into brickwork. The cornice is not to project more than 9in. (or 12in.) from the face of wall, and to be jointed as shown in detail, set in fine mortar or cement, and covered (if necessary) with two courses of tiles in cement, breaking joint. The frieze to be carefully and artistically modelled, and be left clean and sharp, and to be done to the satisfaction of the architect. All the arrises and mouldings to be left in true line and sharp.

7. *Gable*.—The gable to be executed in terracotta with plain facings, as described above, and with piers or pilasters at distances apart as shown (see sketch p. 591), and of a width of 9in. (or 6in.), and of  $4\frac{1}{2}$ in. (or  $2\frac{1}{2}$ in.) in projection. The whole to be set in fine mortar and weather pointed as the work proceeds. The caps to be cast to design (or to be Doulton and Co.'s pattern). The finials or terminals to be according to detail (or of Doulton and Co.'s, Fig. —) securely fixed on copper rods in cement. The curved ramps or copings to be set out with joints, as shown in drawings, not more than 6in. (or 9in.) apart, with voluted ends set in cement, dowed at the joints where necessary. The window-heads, moulded strings, and modelled ornament to be neatly executed according to drawings and to the architect's satisfaction (or the ornament to be selected from the catalogues of well-known firms), and to be clean and sharp, and the curved mouldings and arrises to be true in line and sharp. Any damaged or warped piece is to be removed and replaced by a perfect piece at the contractor's expense. The whole work to be cleaned down at completion.

The following clauses are suitable to describe a front to a bank or commercial building, the details of which are given in our sketches.

The manufacturer will be held responsible for the prompt delivery of the terracotta by the time it is required. Any damage is to be made good by the manufacturer (or contractor).

8. *Generally*.—The terracotta work to be well burnt red (or stone colour) of even tint, and free from cracks and other defects, and to be executed in accordance with the detail drawings, no piece of terracotta to exceed 18in. cube (or be larger on face than 12in. by 9in.). The surfaces are not to be coloured, nor to be filed, chipped, or rubbed, to remove the skin. The work, especially the moulded parts, arches, &c., to be set out by the manufacturer with the assistance of the contractor, who is to supply the necessary accommodation. Any damaged or imperfect piece is to be replaced at the expense of the contractor. The terracotta to be well bonded, and course with the brickwork, and no joint is to be more than  $\frac{3}{8}$ in. (or  $\frac{1}{2}$ in.) in thickness, and the whole to be set in fine mortar and neatly pointed with a bevelled joint as

the work proceeds. All hollow blocks to be not less than 2in. thick in any part, and to be well soaked in water before being filled with concrete, which is to be composed of 1 part of Portland (or Roman cement), 2 of sand, and 4 of clean ballast to pass through lin. ring.

9. *Arches, Ground Floor.*—The piers and arches on the ground-floor story to be built of well-burnt terracotta, according to the detail drawings, and jointed in accordance therewith with a neat mortar joint not more than  $\frac{3}{8}$ in. thick. All hollow pieces to be filled in solid with fine lime concrete as above described, and to be bonded with the brick backing. The arch blocks to be accurately set out and struck upon proper centres, and the arrises to be left true and regular. The enriched capitals and keystones are to be modelled according to detail drawings and to be clean and sharp. The blocks round brick piers to be well bonded with the brickwork, and flushed in with mortar (or cement mortar), and no piece to be chipped or filed after the burning so as to destroy the skin. Clean down at completion, and leave perfect to the architect's satisfaction.

10. *Window Dressings.*—The first and second-floor windows to be executed in accordance with the detail drawings, the pieces of terracotta to be well burnt and true in line, and to be jointed as shown. The semi-octagonal pilasters on each side of the windows to be bonded into the brick backing every other course  $\frac{1}{2}$  (or 9in.), and the arrises and mitres of strings and caps to be true and sharp. No piece is to be filed or rubbed after the firing. All hollow pieces are to be filled in with fine concrete as above described, and the work to be well flushed in with mortar. The joints are not to be more than  $\frac{1}{8}$ in. thick, and to be neatly pointed as the work proceeds.

The transoms and heads of windows to be jointed with joggle joints as shown, and to be kept true in line, and the reveals and mullions of terracotta to be straightened and kept true near the casement frames.

#### THE SOCIETY OF ARCHITECTS.

THE sixth ordinary meeting of the Society of Architects was held at St. James's Hall, Piccadilly, on Thursday evening in last week, Mr. Silvanus Trevail, of Truro, vice-president, in the chair. Mr. George Herbert Gray, of Botfield House, Bexhill-on-Sea, was duly elected by ballot as a member, and a number of donations to the library were announced and acknowledged with thanks.

#### THE DECORATIVE USE OF MOSAIC IN ARCHITECTURE.

A paper on this subject was read by Mr. SCHLENTHEIM, of Messrs. Diespeker and Co., and was illustrated by executed examples of mosaic work, by numerous coloured cartoons, and by a series of lantern slides shown on the screen. The lecturer remarked that he proposed to show the many uses and advantages of marble mosaic as a flooring material. What is called Florentine mosaic is, he explained, not much used, and is not very suitable for floors. It is practically a series of geometrical designs produced in slabs of marble, cut by machinery, varying in size from an inch or two up to six inches, ten inches, or even more. It is very effective for the decoration of walls, and has been used with great effect in the Altar of Our Lady, The Oratory, Brompton; but for floors it has all the disadvantages of an ordinary marble-slab floor, particularly that of wearing badly, and is far more expensive.

#### ROMAN MOSAIC

is made up of tesserae, mostly in the shape of cubes, generally varying in size from three-eighths to three-quarters of an inch, and this is the kind which has been mainly used in buildings in England until about 10 or 15 years ago. It is in this kind, too, that nearly all the well-known mosaics both in floors and on walls and all the famous pictures in the Italian cathedrals were executed. Of course, in the case of pictorial work it has mostly been done in Venetian glass, or, as the Italians call it, "smalto." For the purpose of external decoration, this style of mosaic might be used with great effect in spandrels, in tympanium of doorways, windows, and gables, panels of pilasters, stringing of façades, &c., as has been done in many Italian towns. Internally, it might be, and has been, used with great effect for friezes and for the decoration of ceilings. The Holborn Restaurant is probably the largest example in England of the use of glass mosaic for wall and ceiling decoration, and though no doubt the outlay at first was high, probably there are but very few buildings of even

half that size which in the way of painting or redecoration costs so little to maintain. Roman marble mosaic for floors will need very little explanation, as it is probably well known to every architect. It has been laid by us and other firms throughout the country, and if only hard marbles are used it is of great durability. Any design can practically be executed in it. A kind of mosaic, however, that is coming into use more than any other sort of flooring in recent years is what we call Venetian marble mosaic, but what many architects and some firms of mosaic workers call "terrazzo." "Terrazzo" is not the right word, as what was called "terrazzo" by the Italians is nowadays but seldom used in England, and is never done by us. Nowadays "terrazzo" means a mosaic made up of small irregular pieces of marble, which are, so to say, sown or spread out on the top of the cement mastic, then rolled and rubbed down. We used to do this about twelve or fifteen years ago; but found that it did not answer well for the very rough wear to which it was subjected in the busy English towns, although lasting well enough in sleepy Italy. We have gradually worked out a system which looks, if anything, better than "terrazzo," and is far more durable, having the great advantage of all colours and patterns going right through. One objection that has been frequently raised by architects and others to the appearance of terrazzo is that it has a sort of plum-pudding appearance, as some say, or German sausage appearance, as others put it. Of course, that depends to some extent upon the lively imagination of the gentleman who makes the objection, and upon his more or less intimate acquaintance with German sausage (I must admit that German sausage on the floor is matter out of place); but there is a little truth in the suggestion, and we have tried, and I believe we have succeeded in producing a Venetian floor which gets rid of this supposed defect, as will be seen firstly by the specimens of Venetian mosaic all white or self-coloured, and in the system of ornamental Venetian which we have perfected in recent years. Only about ten or twelve years ago, wherever the "terrazzo" was used on account of its low price, the borders were still made of Roman cube marble mosaic. This added to the expense, and limited both the use of border-lines, and especially of ornamentation; but this difficulty has been overcome. In all manner of buildings this mosaic has been used—in mansions and in cottages, in theatres and in police-stations, in music-halls and in hospitals, in conservatories, bathrooms, kitchens, engine-rooms, lavatories, sculleries, dormitories, laundries, tank-rooms, and, in fact, in every conceivable sort of building. During the very severe winter of two or three years ago, numberless tiles in pathways and verandahs had to be taken up because they were loosened and damaged by frost, whilst in not a single instance did any of the many mosaic pathways and verandahs which we have laid suffer from this cause. This kind of mosaic lends itself to almost any purpose. For example, about two years ago a stone staircase of the Incorporated Law Society, Chancery-lane, was so worn away that nothing could have been done with it except to replace it by a new one but for our Venetian mosaic, with which we covered the treads, nosings, and risers of the staircase, thus making it practically a new one, more durable than it was originally, and, we believe also, more ornamental—the cost of this being only a slight proportion of what a new staircase would have been. From the

#### SANITARY AND UTILITARIAN POINT OF VIEW,

mosaic is even more to be recommended than for merely ornamental or decorative purposes, and for these reasons it is eminently suitable for infirmaries and similar institutions. We have lately laid many thousands of yards in such buildings, and both architects and doctors before whom the matter has been put have agreed that not only the flooring, but particularly the curved or circular skirting is of great advantage. As you will see from the specimens of this curved skirting in the room, it runs up the wall 2in., 3in., or 4in., as may be desired, and does away with all corners and with the right-angle which is ordinarily formed between the wall and the floor. In this right angle dirt, dust, and moisture will continually lodge, and it is difficult to thoroughly remove them. Sometimes, too, moisture will percolate through this joint at the right angle; all this is entirely obviated by our curved skirting, and this curved skirting adds but slightly

to the cost. As mosaic is impervious to damp, and quite non-absorbent, its advantages in such buildings are self-evident. In many hospitals all the floors of the wards are also covered with mosaic. We have introduced channels in the mosaic floors in lavatories, sculleries, bathrooms, &c., which start perfectly level with the floor at one end of the room and gradually deepen until they reach the trap at the other end. If there is a slight fall in the floor from the other side of the room to the side on which the channel is, it will be apparent that all water will readily flow away, thus not only getting rid of any water that may be spilt, but also affording a quick and efficient means of cleaning or flushing the floor with water. Venetian mosaic is particularly suitable for use in swimming-baths, not only for the entrance, pathways, and dressing-boxes, but also for the bottom of the swimming-bath in lieu of glazed bricks. Not only is it cheaper than glazed bricks, but it is more durable, and its appearance will never be altered for the worse, whilst there is hardly a bath in which glazed bricks have been laid for some time where the glazing of some of the bricks has not come off. A particularly objectionable feature of glazed bricks in swimming-baths is the effect produced upon the eye of any onlooker by the pointing of the bricks under water. As the water is always more or less in motion, even when there is only one person in the bath, a number of dark lines seem to be continually contracting and expanding with every movement of the water, and, so to say, dancing before the eye like a number of rectangular or geometrical cobwebs. This is very distressing to the eye, particularly to the eye of a mosaic manufacturer. In the pathways it is advisable to use the curved skirting previously referred to as a connection between the pathways and the usually slightly-raised dressing-boxes. The gutter, too, which formerly has been done in slate slabs in most baths, can be done in mosaic in the same manner as the channel in hospitals, previously described, and the advantage in mosaic will be that instead of having slate slabs of certain lengths with frequently recurring joints, the gutter can be formed in the mosaic, rising and falling, without any joint whatever. It can be placed near the dressing-boxes, as has been done in some cases, or near the edge of the pathway. In the new swimming-baths at Hull, in which we are laying the mosaic, the whole kerb or coping is done in this Venetian mosaic, the kerb or coping protruding about  $\frac{1}{2}$ in. over the sides of the bath, and being 4in. thick. It can, of course, be made thinner than that.

#### MOSAIC HEARTHES.

A little while ago we took out a provisional patent for hearth and fender or kerb combined, and though we have not pushed the manufacture of this article, and are, therefore, not able to show a better specimen than the one in the room, we think these hearths would come in well in many buildings, especially as they are probably cheaper than the ordinary hearth and marble kerb. They can be done in any colour and in any design. For fire-cheeks, too, mosaic can be used with great effect, not only containing design, but crests, monograms, or mottoes could be very neatly introduced. With both glass and marble mosaic very artistic effects can be produced in dado-work and wall-covering, and we have a number of drawings of such in the room. They are, for such purpose, far more durable than tiles, as it frequently happens that tiles become loose and come off the walls. This does not happen with mosaic, owing to the smallness of the tesserae used. In conclusion, one of the greatest advantages of mosaic from the decorative point of view is that any design, from the simplest to the most intricate, can be executed; that there is no manufacturer's stock in certain patterns which he is anxious to dispose of; no habit of the workman to work to a certain design and to no other; no mould or die or cast which greatly enhances the cost of any new pattern, and which helps to make the manufacturer conservative in design; no limit whatever to the taste and originality of the architect or of the designer; no limit to the power of execution of the mosaic worker, save that set by the imaginings of the artist; architects, builders, and owners are quite free to select, to suggest, to invent, unguided and unfettered by a fixed number of stock patterns. Mosaic must, therefore, be eminently conducive to the exercise of individuality in beautifying our houses, and a great factor in fostering artistic independence and artistic thought.

The CHAIRMAN, in opening the discussion, said until he saw them on the screen he had not known that the mosaics laid down at the Devon and Cornwall Bank, of which he was the architect, would be exhibited that evening. These mosaics were designed and executed by Messrs. Diespeker and Co., and had given the directors of the bank great satisfaction. He must admit he had a great partiality for mosaics. When he was in Rome some twenty years ago, he was struck with the old work of the kind, and noted how effective the ancient mosaics looked, and how well they had worn. The more architects could see of good mosaic work, the more would it assist them in their professional duties. Tiles were very good in their way and in their proper places, but there were many opportunities for using mosaics to advantage, such as banks, conservatories, &c.

Mr. G. GARD-PYE, in proposing a vote of thanks to Mr. Schlenheim, remarked that architects sometimes neglected to provide a proper stable foundation for mosaic work, the consequence being that it cracked. Unless they, as architects, insisted upon having their floors properly laid, justice would not be done to the mosaic manufacturer.

Mr. W. COOPER, of Hastings, who seconded the vote of thanks, suggested that it would be well if the Society of Architects were more frequently to invite manufacturers of special kinds of goods to read papers before them, as members, after listening to such an address as that just given, would be in a much better position in preparing their specifications.

Mr. G. A. T. MIDDLETON inquired as to the differences between Roman mosaics, which, as all know, were made up of tesserae, and the Florentine and Venetian mosaics. There seemed to be much difference of opinion as to the uses of mosaic, but as a floor material he considered it could hardly be surpassed. For wall decoration, its employment might be more open to question. On Easter Sunday he entered the Cathedral of Brunswick, an enormous Romanesque church, the walls of which were covered with the most glorious fresco work, but he could not help thinking how much more beautiful it would have appeared in mosaic than in brilliant colour, for the tesserae would have given the needed texture to the surfaces. For ceiling covering, there was still more question as to the desirability of the employment of mosaic. He differed from the lecturer as to the value of the mosaics in the new work at St Paul's Cathedral and the new work at Aix-la-Chapelle; and to his mind that at St. Paul's was the more beautiful. One could not see from the floor what the design was, but was impressed by the rich blaze of colour, and often by a certain texture in the mosaics. It was that texture which one missed in Salviati's work at Aix-la-Chapelle, and although the design was perfect, he distinctly preferred the effect at St. Paul's.

Mr. ELLIS MARSLAND asked if in swimming-bath work it was necessary to have an asphalt surface under the mosaics, for if the asphalt was unnecessary, the price of mosaics would be brought within reasonable limits for public baths.

In acknowledging the vote of thanks, which was cordially adopted, Mr. SCHLENHEIM said the question of the asphalt foundation did not affect the cost of flooring for swimming-baths at all, since plain mosaic was cheaper than glazed bricks, even of the second or third quality; and his firm had executed mosaic work in baths at 6d. per square yard. But, as a matter of fact, a bed of asphalt was not required, providing that the mosaics were put on a properly-laid bed of concrete. He still differed from Mr. Middleton as to the relative merit of the mosaic work at Aix-la-Chapelle and St. Paul's; he admitted that St. Paul's was indeed a rich blaze of colour, but he did not think that the skill, money, and beautiful design were well expended or placed when the only effect they produced on the spectator was that of a blaze of colour. Mr. Gard-Pye had referred to the cracks in mosaic work; these were due to the cracking of the concrete beneath. If the concrete were properly laid, it would not be fissured, and thus the mosaic work above would remain unbroken; but when once the concrete was cracked the mosaic would be sure to follow. He would emphasise the fact that mosaic work could be executed as cheaply as tiles, and it had been laid in tank-rooms, lavatories, and large factories.

The British Archaeological Association will hold their Congress at Peterborough, from July 14 to July 20.

#### NEW MODE OF PROTECTING THE BANKS OF RIVERS FROM EROSION BY WATER.

THE banks of rivers and canals, whether natural or artificial, are incessantly exposed to a process of destructive disintegration from the eroding action of the running water which is constantly impinging against them. For an example in point, in which the deteriorating influence of a fairly rapidly-flowing stream has taken effect, the river wall protecting the embanked walk along Battersea Park may be quoted. It must be admitted that being composed of a very inferior description of mingled stone and concrete, it is a very poor wall, which, no doubt, accounts for the fact that it is now useless for the purpose for which it was originally intended, and that the London County Council intend repairing it where possible, and rebuilding it where not. There is no doubt that experience has shown that both banks of a navigable waterway are simultaneously affected by running water, but not by any means to the same extent. In all instances it is the concave bank, when the course of the stream is of a curvilinear contour, that suffers most. In fact, in some cases and under certain conditions the opposite or convex bank scarcely appears to be injured in any way. The ordinary methods in use among engineers and builders, and adopted by them to protect the banks, are various. Sometimes a wall constructed of fascines, and well payed over with clay, will answer sufficiently. At other times a timber wall, built of main piles, 12in. by 12in., with

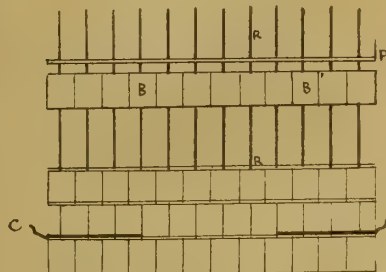

FIG. 1.

struts, ties, and stringers, all braced together by vertical sheeting piles, will afford the protection required. Again, the proposed goal may be reached by the employment of a long wooden coffer dam or hollow wall, filled in from front to back with stones, and reinforced at the base on the outside by the deposition of large blocks and pieces of rockwork. When all these means fail, recourse must be had to the only and *dernier ressort*—that is, the solid, massive wall of carefully-executed masonry. Our Metropolitan river walls are splendid examples of this never-failing mode of protection.

One of the principal objects to be attained by these riverain walls is to divert the current, or the "wash," as it might be termed, from the shore or bank, and throw it more into the direction or axis of the stream. In this manner not only is the direction of the wash very sensibly modified and ameliorated, but the bed of the waterway is deepened by the increase of scour subsequently induced. Most of these methods of dealing with hydraulic questions, which are continually occurring, are not only of a costly character, but call for the exercise of considerable skill, experience, and much time before they can be carried out. They cannot be suddenly improvised to serve as mere temporary or palliating measures, and require a thorough professional survey and study of the whole of the particular part of the stream which will be affected by the proposed new work. It is a more or less ticklish matter to interfere with the natural course of any river or stream. They always resent it, and if prudent counsels do not prevail, and a too coercive régime be adopted, not only is the object aimed at frequently defeated, but a good deal of damage is done, so that it may be truly said, the last state of the river is worse than the first. A new mode of procedure which is well worthy of notice has been recently introduced with excellent results on some of the Italian waterways. The principle involved is quite the reverse of that belonging to the more usual methods. Instead of endeavouring to replace a natural bank damaged by aquatic erosion by an artificial one of a more solid and substantial

character, the bank is covered with a light and pliable facing. This flexible protector is, in fact, nothing else than a particular example of a combination of brickwork and iron. The body of the facing (see Fig. 1) is composed of specially prepared pressed bricks, B B, through which are passed iron rods R R. One course of bricks is shown lifted up in Fig. 1, which may be regarded as one length of the facing. In order to connect successive lengths, chains, C C, are run through the rods at suitable intervals, and thus unite the whole longitudinally, while the rods perform a similar duty both vertically and horizontally. The rods are all held together by a perforated plate, P, through which they pass at every course of bricks, each of which weighs 20lb. All the metalwork is galvanised to preserve it from rusting through the action of the mortar and other contributing causes. Each length measures about 25ft., and they are readily placed *in situ* by suitable machinery fixed up in a boat. Rapidity and facility of execution and a comparatively very low cost are the distinguishing characteristics of this new protector for river banks, and we add to these features that lengths of it can be made in advance and kept in reserve for any emergency. Its advantages and merits are too obvious to require further description. T. C.

#### STEEL AND CONCRETE COMBINATIONS.

AN interesting paper on "Steel Concrete Construction" appears in the *Transactions* of the Society of Civil Engineers. The author, Mr. George Hill, Assoc. Am. Soc. C. E., deals with certain combinations of concrete and steel, in which the latter acts in tension, and is distributed through the bottom section of the slab. The best results are obtained when the compression is taken by the concrete and when the metal employed is so placed as to occupy the position of the extreme fibre on the tension side. The steel requires to be held in place by some means possessing greater strength than simple cohesion between it and the concrete. Tests have been consequently very difficult, and no formula has been made that will account for the high resistance of sections tested under concentrated loads. Mr. Hill describes a series of tests made upon 56 slabs of concrete and expanded metal of varying spans and thicknesses both of concrete and of metal, supported on T beams of uniform widths. The materials used for the concrete were as follows:—The cement used was American Portland and a slag cement. For the first the manufacturers claim a fineness of 90 per cent. on a No. 100 sieve, and of 70 per cent. on a 200 sieve. A minimum tensile strength of neat cement for seven days of 400lb., and for 3 parts of sand to 1 part cement seven days, 150lb. was guaranteed. Under actual test the tensile strength exceeded the guaranteed, the average of 30 tests giving 624lb. The sand was Cow Bay sand clean and sharp and of varying sizes, ordinary steam cinders were used of varying fineness, and the stone was trap broken to pass a 1½in. ring. The metal used was the expanded metal made from high grade low-carbon Bessemer steel. The testing machine is minutely described, and the results are summarised in a series of tables to which we refer the reader. The application of the load was at a uniform rate. The deflections were also at a uniform rate, and were proportionate to the load up to the point where the elastic limit was reached, after which they increased considerably; the bottom surface of concrete began to show the compressing action of the strands of metal by breaking into small cracks and puckering up. In no case was there any collapse of the section until ample warning had been given, and then not till the rate of thickness of slab to span was far less than would be allowed in practice. The first crack in most cases developed over the inner edge of the T beam supporting the slab; the centre of the slab usually crushed under the loading plank. The tests show much irregularity and indicate the necessity of a more uniform method of mixing the concrete. The author further remarks in relation to these tests: "The strengths shown by the mixtures in which slag cement was employed are worthy of note, since the neat tensile strength tests showed a less strength than those in which American Portland was used, while in the actual use of the cement this difference disappears, and seems to indicate a considerable advantage, due to fineness of grinding." He says: "These tests show that a centrally-applied load of 3,200lb. produces a deflection sufficient to crack plaster, a compressive

strain of 300lb. per square inch in the concrete, and a tensile strain on the metal of 322lb. per inch of width, and a load of 4,580lb. reached the elastic limit, producing a compressive strain of 400lb. per square inch in the concrete, and a tensile strain of 500lb. per inch of width on the metal." An examination of the table shows varying results for similar conditions—as, for example, slabs made with the same mixture of concrete vary as much as those made of other mixtures. Other irregularities are noticed, to be accounted for only by the differences due to fineness of the cement used. In some instances the steel failed before the concrete.

ELECTRIC LIGHTING NOTES FOR ARCHITECTS.—XXII.

By AN ASSOC. INST. ELECT. ENGS.

CIRCUIT TESTING.

**L**EAKAGE CURRENTS AND THEIR MEASUREMENT.—When we remember that an electric light or power cable is subjected to an electric pressure all the time that it is active, and that it is liable to mechanical injury during the wiring or laying of the cable, it is obvious that small faults, insignificant in themselves perhaps, should be removed as early as possible, since the accumulation of small faults results in excessive leakage, and this means waste of power and money and possible danger. And what is more important, the insulation covering of cables tends to deteriorate, especially if dampness be present, as then the insulating qualities of the covering rapidly diminish, and electrolytic action is set up, with

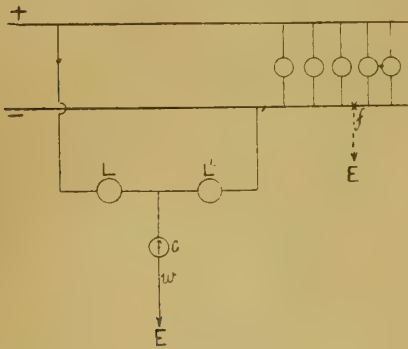

Fig. 75.

the result that the conductor is eaten through, or a short-circuit occurs. And although the resulting leakage currents may eventually attract attention, either in consequence of electrolytic action, heating, or other prejudicial effects, it is of the utmost importance that frequent tests be made, so that the faults may be detected and removed. And although it must be admitted that much good work is done, it is equally true that defective and inferior work is also done, and anyone who has inspected and tested wiring work knows only too well that many of the following defects which are met with could, and would, be prevented by conscientious wiremen. The most common defects are—(1) inferior material, (2) wires in electrical contact at crossings for tees and branches, (3) contact between a conductor and the earth, (4) absence of casing or other protection on passing through walls and between floor and ceiling, or behind wainscoting, and at the back of switchboards; (5) defective and badly insulated joints, in consequence of which moisture penetrates and saturates the insulating covering; (6) inferior connections to fittings, and defective fittings; (7) faulty places in the covering due to cuts or abrasion during wiring; (8) junction-boxes not water-tight; and (9) indiscriminate selection and use of fuses.

Faults are in practice usually divided into two classes, *partial earths* and *dead earths*, the term "earth" denoting a defective part of the wiring, the potential of which, in consequence, approaches that of the earth. A *partial earth* is a defective part not making actual metallic contact with the earth, whilst a *dead earth* occurs whenever actual metallic contact is made with the earth. It is obvious that a dead short-circuit results when there is a dead earth on both the positive and negative mains. When this happens the main fuse blows, as then the resistance of the

circuit is a minimum and the current a maximum. To avoid partial earths becoming dead earths, periodic testing for faults should be made; since there is not the possibility of leakage currents making themselves self-evident so early as is the case with gas and water circuits. Many interesting and effective methods of testing the character of the insulation of circuits have been devised,

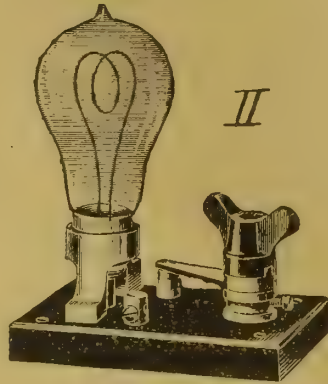
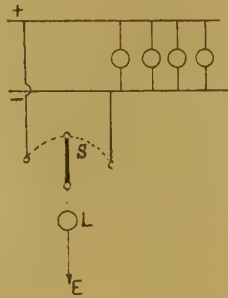

Fig. 76.

and the following notes are given with the hope that private and isolated plants and private houses may be thoroughly protected from danger and waste of electrical energy.

It may be remarked here that inasmuch as an installation is thoroughly tested before the current is turned on, this is often thought sufficient; and since the ordinary methods of testing the insulation resistance of an installation—i.e., by means of a testing-set, &c.—are not applicable on an active or live circuit, the matter is neglected. Means, however, should be at hand for giving continuous indications of the insulation in all cases, so that any deterioration or defect may be determined as soon as it occurs, and it is noteworthy that very approximate values for the insulation resistances of the mains individually, or of the combined installation, may be obtained during the working of the circuit. The methods to be described depend upon the fact that there is no substance which is an absolute insulator, and that the resulting leakage current enables readings to be taken which give a measure of the quantities desired. At the outset it must be understood that it is impossible to fix an absolute value for the insulation resistance of all installations. The working

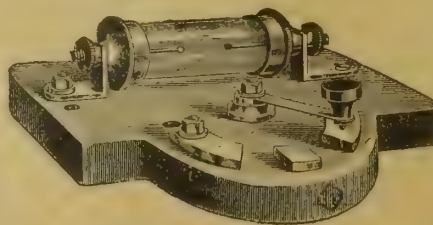

Fig. 77.

pressure and the number of lamps in use, or the magnitude of the current utilised, must be taken into account, and as these vary, so will the insulation resistance vary, and still give satisfactory results.

**Leakage Indicators.**—The simplest continuous telltale is arranged as follows, and shown in Fig. 75. Two identical glow-lamps, L and L', of a voltage such that they would be fully illuminated if

placed separately between the mains, are joined in series, as shown, in which case they furnish only a reddish light—i.e., burn at a dull red. The wire connecting these lamps, however, is perfectly earth-connected by means of the wire *w*, in the circuit of which a trembling-bell or galvanometer is interposed, as shown. As long as the insulation of the circuit is satisfactory no current passes to earth along *w*, and the bell or galvanometer is inactive. The aspects of the two lamps are identical. As soon as a fault occurs, however, the wire *w* is traversed by a leakage current, and the bell or galvanometer is set in action. Furthermore, the lamp connected to the perfect main glows more brightly, whilst the other, connected to the faulty main, glows less brightly. To understand this action, let us suppose that the fault is at *f* on the negative main: it is evident that the insulation resistance of this main will be lower than that of the positive, so that a current may flow through L and the indicating instrument to earth, and so complete its circuit through the weak point *f*. As a matter of fact, the lamp L' is shunted by this leakage circuit, and consequently receives less current. In this way unequal brilliancy indicates unequal insulation resistances of the mains, and it must be remembered that the defective main is connected to the lamp burning less brightly. The weakness of this test, which is so simple, is that equal brilliancy results if both mains have equally a low-resistance.

In some cases the evidence of a single lamp suffices, and although this does not form a permanent continuous leakage indicator for both mains, it is a convenient arrangement for making

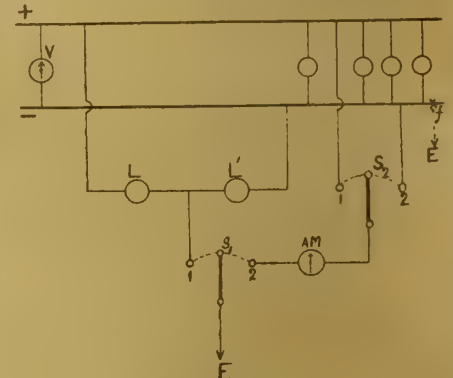

Fig. 78.

periodic tests. As represented in Fig. 76 I., one terminal of the lamp is permanently connected to the switch-arm of a two-way switch, S, whilst the other is permanently earthed, and the mains are connected to the two studs of the switch. On moving the switch-arm to the right and left, each main is in turn put to earth, and if the lamp lights up, the main not connected to the switch-arm is defective. A leakage indicator of this type is shown in Fig. 76 II. It is sold by Messrs. Berend and Co., Limited.

Another very simple and effective leak detector, introduced by Messrs. Woodhouse and Rawson, is shown in Fig. 77, and is interesting, as it depends upon electrolytic action. As is well known, decomposition takes place whenever a compound liquid is interposed in an electric circuit, and either a metal is deposited, gases set free, or a discolouration at the electrodes is produced. It is this discolouration effect which is utilised in this detector to indicate the existence of a leakage current.

The appliance consists of a switch-key and a pole-indicator, the latter being a glass tube containing a white transparent liquid in which two platinum wires are supported by the metal stoppers which close the tube and form the terminals. The gap between the platinum wires is such that there is about  $\frac{1}{16}$  in. of the liquid between them, and if a current is passed from one to the other the liquid is decomposed, and the negative pole is at once covered with a purple tinge by the electrolysis of the liquid. The decomposed substance is rapidly dissolved again by the liquid on the cessation of the current, and the white colour of the liquid is restored. The resistance of the liquid between the platinum wires is about 30,000 ohms; but the indications of the current are quite apparent, with a difference of potential between the terminals as small as four volts.

For use as a leak detector, one terminal of the

pole-indicator is connected permanently to earth, and the other to the switch-arm, whilst the mains are connected to the right and left contact-pieces of the switch. By moving the clapper key to the right or left, each main is put separately to earth by depressing the key, and if any leakage exists, discolouration at one of the electrodes will result; if no discolouration ensues, the line may be taken to be in good condition. When this appliance is out of use the arm of the switch is placed on the central dummy contact-piece. As the full electro-

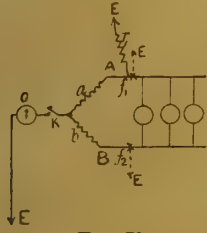

FIG. 79.

motive-force of the circuit may be used in making the test, only momentary contacts should be made. This detector is extremely useful for periodic tests.

Sir David Salomons, Bart., has devised a simple appliance for use in private houses. He describes it as follows:—"It is a high resistance galvanometer, taking the place of the pole-tester, and a double spring-key replacing the switch. This key is so arranged that no contact is made except when one end or the other of the lever is pressed. The lever is constructed in such a way that only one contact can be made at a time. The galvanometer is protected by a heavy iron case from outside electric influences. In the improved form there is an additional little switch, which can assume two positions. Turned one way, the instrument is ready for testing; turned the other, it can be used as a voltmeter. The scale is graduated in degrees, divisions of megohms, and volts. There is also an indicating needle, which is set to the margin of safety, allowed in the house where the instrument is placed. It is only necessary for one of the servants every morning to press successively the buttons on the lever, and to note that the needle does not pass the fixed pointer on the dial. If this should happen, the fact will be reported to the head of the house, and he will naturally call in someone competent to discover the fault. When such an instrument is employed in a house, it is generally desirable to have an independent battery of dry cells, and to place them in circuit after cutting the D P (double-pole) main switch, to make sure that any leakage indicated is that existing in the house, and not due to any faults outside it. The manufacturers, Messrs. Elliott, will always mark the dial to indicate the limit of deflection permissible in any given installation by marking a red line, against which is placed 'danger.' This would render the house safe."

*Quantitative Tests without Interrupting Work.*—The following is a simple and practical arrangement which could be used in isolated plants with good results. In Fig. 78, let V denote the voltmeter connected between the mains, S<sub>1</sub> and S<sub>2</sub> two

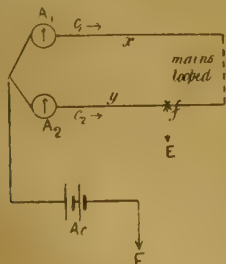

FIG. 80.

two-way switches, and A M a suitable ammeter. From what has already been said, it will be clear how to find on which main a fault is by simply using the switch S<sub>1</sub>. To determine the resistance of a fault, supposed to be at f on the negative main, proceed as follows: Place the switch-arm of S<sub>2</sub> on stud 1, and the switch-arm of switch S<sub>1</sub> on stud 2; in which case suppose the ammeter to read c amperes, and let V indicate the differ-

ence of potential between the mains as given by the voltmeter. Then, if r<sub>v</sub> is the resistance of the ammeter, the resistance of the fault will be—

$$f = \frac{V}{c} - r_v.$$

The following method, due to Dr. Hopkinson, is suitable for estimating the insulating resistance of each main. Suppose the insulation resistance of the positive and negative to be f<sub>1</sub> and f<sub>2</sub> respectively. The ends A and B of these conductors are connected by means of adjustable resistances a and b to one terminal of the key K, the other terminal of which is connected to earth through the galvanometer G, as shown in Fig. 79. Then, if a and b be adjusted so that there is no deflection—

$$\frac{f_1}{f_2} = \frac{a}{b}, \text{ or } f_1 b = a f_2.$$

Now introduce an artificial leak of resistance r<sub>1</sub> to earth, so as to be in parallel with f<sub>1</sub> (say), as indicated in Fig. 79, and again adjust the variable resistance a<sub>1</sub> and b<sub>1</sub> (say) to give zero deflection, then—

$$\frac{f_1 r_1}{r_1 + f_1} = \frac{a_1}{b_1}$$

since f<sub>1</sub> and r<sub>1</sub> are in parallel.

$$\therefore b_1 f_1 r_1 = a_1 f_2 (r_1 + f_1);$$

but—

$$f_2 = \frac{f_1 b}{a}$$

$$\therefore b_1 f_1 r_1 = \frac{a_1 f_1 b}{a} (r_1 + f_1),$$

and—

$$a b_1 r_1 = a_1 b r_1 + a_1 b f_1,$$

from which—

$$f_1 = \frac{r_1 (a b_1 - a_1 b)}{a_1 b}.$$

Similarly f<sub>2</sub> may be determined.

If the fault be known to exist in one of two branches, its position may be approximately

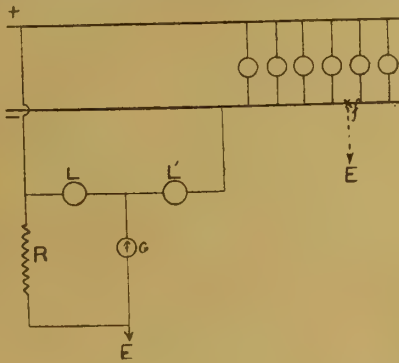

FIG. 81.

found by using two ammeters simultaneously. The far ends of the branches are looped as shown in Fig. 80, and the near ends are connected through separate ammeters A<sub>1</sub> and A<sub>2</sub> to one pole of a source of electricity, dynamo or accumulators, the other pole of which is earth connected as shown. Then if x = length of A<sub>1</sub>f, the resistance of which (including that of the ammeter A<sub>1</sub>) is R<sub>1</sub>; and l = the total length of the loop A<sub>1</sub>fA<sub>2</sub> = x + y; whilst R<sub>2</sub> = resistance of segment A<sub>2</sub>f or y; and C<sub>1</sub> and C<sub>2</sub> = the readings of the ammeters A<sub>1</sub> and A<sub>2</sub>—

$$\frac{C_1}{C_2} = \frac{R_2}{R_1} = \frac{y}{x} = \frac{l - x}{x},$$

since R<sub>2</sub> and R<sub>1</sub> are in parallel.

$$\therefore C_1 x = C_2 (l - x) \text{ and } x = l \frac{C_2}{C_1 + C_2}.$$

Similarly—

$$y = l \frac{C_1}{C_1 + C_2}.$$

M. Picou has also introduced a simple modification of the method of detecting a leak for determining the resistance of a fault. The arrangement is shown in Fig. 81, and consists in introducing a rheostat, so that resistance may be introduced to bring the galvanometer reading back to zero. Let us suppose that a fault exists at f on the negative main as shown. Then as we have already shown, the galvanometer needle is deflected, and the lamp L (which glows more brilliantly than L'), together with the galvanometer may be looked upon as a shunt to L<sup>1</sup>. By introducing the rheostat as shown, the lamp L is shunted, and the resistance may be so adjusted that the galvanometer needle is not deflected. In this case the resistance introduced is approximately that of the fault. To get a more exact

result the lamps are interchanged, and a second reading taken; then if R<sup>1</sup> be the second resistance introduced by means of the rheostat, the actual resistance of the fault is the square root of the product of the two readings. From the first test we get—

$$\frac{L}{L^1} = \frac{R}{x}, \text{ or } Lx = RL^1,$$

where x is the resistance of the fault. From the second test we get—

$$\frac{L^1}{L} = \frac{R^1}{x}, \text{ or } L^1 x = R^1 L,$$

and by multiplication—

$$x^2 = RR^1, \text{ or } x = \sqrt{RR^1}$$

For continuous indications it is a common practice in supply stations to use recording voltmeters instead of two lamps, and, as will be seen, much valuable information respecting the insulation of a circuit can thus be determined. To simplify matters, we shall assume that one voltmeter is used to determine separately the differences of potential between earth main and the earth. If one terminal of the voltmeter be permanently earth-connected, as at O in Fig. 82,

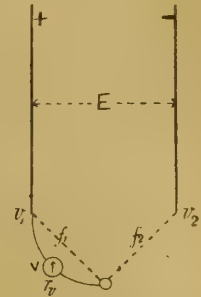

FIG. 82.

these differences of potential may readily be determined. Let E be the voltage between the two mains, v<sub>1</sub> and v<sub>2</sub> the differences of potential between the positive and negative mains and the earth respectively, f<sub>1</sub> and f<sub>2</sub> the insulation of these mains respectively. Then, when taking the difference of potential between the positive main and the earth (as shown in Fig. 82), the voltmeter is a shunt to f<sub>1</sub>, and we have a two-branched multiple-arc circuit to earth, or, in other words, the voltmeter of resistance, r<sub>v</sub> is one branch, and the insulation covering of resistance f<sub>1</sub> the other. Then, current through voltmeter + leakage current from positive main = current from earth to negative main, or in symbols, if v<sub>1</sub> = difference of potential between positive main and the earth.

$$\frac{v_1}{r_v} + \frac{v_1}{f_1} = \frac{E - v_1}{f_2} \dots\dots\dots(a)$$

$$\text{and— } v_1 \left( \frac{1}{r_v} + \frac{1}{f_1} + \frac{1}{f_2} \right) = \frac{E}{f_2} \dots\dots\dots(b)$$

$$\text{or— } v_1 \left( \frac{1}{r_v} + \frac{1}{F} \right) = \frac{E}{f_2} \dots\dots\dots(c)$$

where  $\frac{1}{F} = \frac{1}{f_1} + \frac{1}{f_2}$ , since the insulation resistances f<sub>1</sub> and f<sub>2</sub> are in parallel, and F = total insulation resistance of the circuit.

Similarly, for the negative main—

$$\frac{v_2}{r_v} + \frac{v_2}{f_2} = \frac{E - v_2}{f_1} \dots\dots\dots(d)$$

$$\text{and— } v_2 \left( \frac{1}{r_v} + \frac{1}{f_1} + \frac{1}{f_2} \right) = \frac{E}{f_1} \dots\dots\dots(e)$$

$$\text{or— } v_2 \left( \frac{1}{r_v} + \frac{1}{F} \right) = \frac{E}{f_1} \dots\dots\dots(f)$$

Adding (e) and (f)—

$$(v_1 + v_2) \left( \frac{1}{r_v} + \frac{1}{F} \right) = \frac{E}{f_1} + \frac{E}{f_2} = \frac{E}{F}$$

$$\therefore v_1 + v_2 = \frac{1}{F} [E - (v_1 + v_2)]$$

$$\text{And— } F = r_v \frac{[E - (v_1 + v_2)]}{v_1 + v_2} = r_v \left\{ \frac{E}{v_1 + v_2} - 1 \right\} = \text{total insulation resistance of circuit.}$$

Again, from (e) and (f)—

$$\frac{v_1}{v_2} = \frac{f_1}{f_2}, \text{ and } f_2 = f_1 \times \frac{v_2}{v_1}$$

Substituting this value in (a), we get—

$$\frac{v_1}{r_1} + \frac{v_2}{r_2} = \frac{(E - v_1)}{f_1} + \frac{v_2}{f_2}$$

$$\therefore \frac{1}{r_1} + \frac{1}{f_1} = \frac{E - v_1}{f_1 v_2}$$

and—

$$\frac{1}{r_2} = \frac{E - v_1}{f_1 v_2} - \frac{1}{f_2}$$

$$= \frac{E - (v_1 + v_2)}{f_1 v_2}$$

Therefore—

$$f_1 = r_1 \frac{[E - (v_1 + v_2)]}{v_2}$$

Similarly—

$$f_2 = r_2 \frac{[E - (v_1 + v_2)]}{v_1}$$

To determine the leakage current—

$$C = \frac{E}{f_1 + f_2}$$

$$= \frac{E}{r_1 \frac{[E - (v_1 + v_2)]}{v_2} + r_2 \frac{[E - (v_1 + v_2)]}{v_1}}$$

$$= \frac{E v_1 v_2}{r_1 (v_1 + v_2) [E - (v_1 + v_2)]}$$

*Expressions for the Insulation Resistance of a Circuit.*—It will be interesting at this point to refer to the different methods of stating the insulation resistance of an installation. It is obvious that—

(1) The insulation resistance should be directly proportional to the electromotive-force of supply, and—

(2) The insulation resistance should be inversely proportional to the length of the circuit, which may be denoted by the maximum current or the number of lamps installed.

(a) The Institution of Electrical Engineers' Rule gives—

$$R_i = \frac{\text{constant}}{\text{current}} = \frac{K}{\text{max. current}}$$

and—

$$K = 10 \text{ megohms.}$$

(b) Many supply and insurance companies—

$$R_i = \frac{\text{constant}}{\text{no. of lamps}}$$

(c) Maximum leakage current allowed. Maximum leakage current—

$$c = \frac{\text{current}}{\text{constant}} = \frac{1}{K} \times \text{max. current.}$$

The value of K fixed by the Board of Trade is K = 10,000.

$$\text{Since leakage current} = \frac{E}{K_i} = \frac{1}{K} C = c.$$

$$\therefore R_i = \frac{K E}{C} = 10,000 \frac{E}{C} \text{ (Board of Trade.)}$$

$$= 10,000,000 \frac{1}{C} \text{ (Institute's Rule.)}$$

(d) Professor Jamieson's rule introduces pressure of supply, or—

$$R_i = K \frac{E}{N} \text{ (N = number of lamps.)}$$

By fixing K at 0.1 megohm, it is clear that R<sub>i</sub> should not be less than 100,000 ohms per lamp for every volt employed.

(e) In Picou's rule, as given before the International Society of Electricians, Paris, in 1888, both the pressure and current were introduced, thus—

$$R_i = K \cdot \frac{E}{C}$$

and since  $\frac{E}{C}$  = conductor resistance, it is possible to express insulation resistance in terms of the conductor resistance, or R<sub>i</sub> = K . R.

(To be continued.)

#### THE SURVEYORS' INSTITUTION.

AT the ordinary general meeting, held on Monday last in Savoy-street, the discussion was resumed on Mr. H. M. Grellier's paper on "Tithe Rent-Charge Redemption."

Mr. J. W. Kemsley, speaking as a tithe collector, as a tithe payer, and as a tithe owner, said that he found no desire on the part of the tithe payers to redeem, even though terms were offered better than those proposed by Government.

The Rev. D. Lamplugh said that the successful working of the various Tithe Acts—from that of 1836 to the Act of 1891—was due mainly to the honesty and straightforwardness of the men who

acted between the owners and the payers. He, personally, should like to see Tithe Rent-Charge fixed at £70 per £100 free of variations and free of local rates. If the value rose, as it now seemed likely to do, landowners would feel the pinch, as their rents would not rise proportionately.

Mr. Holbeche said that most landlords received their Michaelmas rents in January, and were, therefore, glad to avail themselves of the three months' grace for paying the tithe.

Mr. J. H. Sabin pointed out some essential differences between the provisions of the Tithe Act, 1891, and the Finance Act, 1896, the one recognising the separate ownership of the land and the tithe, and the other taking them as one ownership.

Mr. Daniel Watney said he was surprised, after merging some tithe rent-charge, to find that he was still charged with the same Income-tax and Land-tax.

Mr. Grellier, in reply, said that the bare mention of tithe rent-charge seemed to deprive some persons of all judicial reasoning, and he believed that the Act of 1891 had done great good by transferring the question from the hands of agitators, to that of landowners, who were outside that influence. The calmness was also, he thought, in part due to the fall in the corn averages, which controlled the value of tithe rent-charge, and in part to sympathy with the clergy, whose incomes from tithe had during the last 20 years been reduced about 40 per cent. The Act had also provided a sort of safety-valve for the incensed tithe-payer, who could take his case into court and then calmly submit to the judgment of His Honour that he must pay, which he generally did with but little grumbling. The difference between corn rents and tithe rent-charge was, broadly speaking, that while they both varied in value with the varying price of corn, the former were leviable and recoverable under the provisions of local Acts, while the latter were controlled by the Tithe Act of 1836. Where a landowner wished compulsory redemption of tithe he must comply with the terms of the Act, and pay, generally speaking, 25 years' purchase; but, of course, two parties could agree between themselves to voluntarily redeem at any price they liked to fix, if one were a lay impropriator owning the land in fee simple. He thought that both the parties, tithe-owner and tithe-payer, were fairly satisfied under the present arrangement, as provided by the Act of 1891.

The discussion on Mr. Blashill's paper, read at Manchester on April 20, entitled "Lessons from Fire and Panic," was then resumed. Mr. A. Harston said that in his opinion a fireproof building had not yet been contrived, and all that was really attainable was a building which would retard the progress of a fire. If he had to build an absolutely fireproof building, he should be compelled to design it like a beehive, and stop up all means of access of air. The nearest approach to "fireproofing" was to employ materials which would resist fire as long as possible. Coke breeze concrete was valuable, not only that it was fireproof, but that it was light, and gave the opportunity of nailing down the boards to it, so that there was no dangerous air space under them. If possible, wooden floors were to be avoided. The great disadvantage of using firebrick as a material for concrete was its weight. Pumice was light and good but expensive; while coke breeze was cheap, costing only something like 5s. a ton; but it must not be forgotten that under intense heat coke breeze expanded considerably—in a length of 28ft. it would expand some  $\frac{1}{4}$ in. under a temperature of 3,000°, and would soon break up altogether. He remembered an objection being raised by the chief officer of the Fire Brigade that he could not make a hole in a roof, built with the intention of making it fireproof, for the purpose of getting water into a burning building. It was becoming increasingly important in London to have roofs that could be walked over. So many telephone and telegraph men damaged one's roof that it was difficult to keep it watertight. Matchboarded walls in factories and shops were a distinct danger; but he knew of many important modern buildings which were match-lined throughout five or six stories.

Mr. A. R. Stenning said that the author of the paper had, of course, exceptional opportunities of obtaining information as to the causes and the means of prevention of fires in London, and his paper must therefore be one of great value to all surveyors practising in large

cities. It was, he thought, practically impossible to make any large building absolutely fireproof, for iron or steel girders and joists, however well cased in, were liable to twist and thrust out the walls. He agreed that the most important matter was to use fire-resisting materials as far as possible, which could be relied on to keep any outbreak of fire confined within a small space. He had himself used in erecting artisans' dwellings some 6½ acres of flooring composed of steel joists with fireclay pipes notched to the lower flange, and the whole filled in with coke breeze, thus making a light and almost indestructible floor. He had one fire during the construction of these buildings, which broke out among the very inflammable materials of a room used as a joiners' shop, but it spread no farther than that room, and did very little damage to the structural fittings. He might say that the lintels were of coke-breeze concrete, and not of wood. Mr. Stenning also mentioned an experience of his own when staying at an hotel in Scotland, where he was awakened to find the corridor full of smoke. There was a special arrangement for breaking a glass door and obtaining a key of an "escape staircase" which would have led him directly into the seat of the fire; but, fortunately, he adopted the ordinary route, and came down by the main staircase quite safely, although at some inconvenience. Good wood beams seldom burned through. They would char, but remained serviceable for some time. Party-walls carried above the roof were certainly useful, especially in warehouses and factories. He did not think that any legislation could provide against loss of life by panic; but every reasonable facility for escape should, of course, be provided.

Mr. A. Vernon said that if a mathematician were to calculate the chances of loss of life by fire, he would probably multiply the density of population by the height of the buildings. In rural districts loss of life from fire was very rare. In towns the risk as regarded public buildings was multiplied by overcrowding and by difficulty of exit. In Chicago, which had, perhaps, the very greatest experience of fire, every house was, as far as possible, now protected from fire risk, and every facility was given for escape. Lifts were always dangerous, even more so than stairs, and he looked forward to the time when they would be banished to some exterior structure apart from the main building. Stone and iron, which seemed naturally the most fire-resisting materials, had both proved to be unreliable, and good hard timber was about the best friend the firemen had. The greatest church fires, or rather losses of life from panic resulting from fire, had been where the doors were insufficient and opened inwards only. To sum up the matter, flues must be well guarded: 4½in. was sometimes well enough, but was insufficient in the case of large stoves or furnaces for heating. Combustible materials must, as far as possible, be eliminated, and every door of a public building must be made to open outward.

Mr. C. John Mann asked whether Mr. Blashill could tell the meeting whether hollow brick walls, which so usefully kept out damp, contributed to danger in the case of fire?

Mr. Blashill, in reply, said he had chiefly addressed himself in the paper to the question of fire in relation to danger to life, for the subject was a wide one, and his time was limited. Property could be insured and reinstated, but life could not. He could hardly admit that the regulations of the County Council were harassing, and the very nature of things prevented them from being final. They must necessarily vary as circumstances varied. In London there had, fortunately, not been much recent experience of large fires in public buildings while the buildings were occupied; but it was the duty of the body for whom he acted to provide against the very worst that might happen. They published all their regulations so that everyone could understand them, and endeavoured to meet every case fairly and reasonably. As to cost, if cost was incurred which was unnecessary, the money was certainly wasted; but if cost could by any means be shown to contribute to the preservation of life, it could hardly be unnecessary. He agreed with Mr. Harston and Mr. Stenning, that many of the inflammable materials now or formerly used might be superseded. Wood lintels and wood bricks, for instance, were not now necessary. He was sorry that he could not answer Mr. Mann's question as to hollow walls, as he had no experience of their behaviour during a fire.



## MUSEUMS OF THE SCIENCE AND ART DEPARTMENT.

**T**HE Select Committee appointed to inquire into and report upon the administration and cost of the Museums of the Science and Art Department have agreed to the following first report:—

Since the issue of the report of the Museums of the Science and Art Department Committee in July, 1897, your committee have continued the inquiry, but reserve for a further report the publication of additional evidence with their final review and recommendations.

They feel, however, bound to report without delay certain conclusions at which they have arrived, on consideration of the evidence, as regards the South Kensington Museum and the Geological Museum in Jermyn-street.

They are unanimously of opinion that with a view to present efficient management, to economy of administration, to future development of the collections, and to their full use for the purpose of exhibition and of instruction, it is necessary:

1. That the whole area on the east side of Exhibition-road (except that occupied by the Royal College of Science, which will not be sacrificed except at great cost), be exclusively devoted to the Art Museum and the Art Library, with provision for the conduct of the business connected with loans of art objects and the art schools. They are satisfied that the whole of this space is required for the art schools, the due exhibition of the art collections, and the administration connected with such a museum.

2. That provision for the whole of the science collection, the science library, for loans of scientific objects, and for the science schools be made on the west side of the Exhibition-road.

They are convinced that this concentration of art on one side of the road and of science on the other is essential to good administration, to satisfactory results from the money expended, and efficiency both in the museum and in the schools. This arrangement would allow space for the future development both of the art and of the science branches.

They also unanimously recommend that the Geological Museum in Jermyn-street be no longer occupied for the same purposes as now; and that the collections there exhibited be removed to the west side of Exhibition-road and made part of the science collections.

## BOOKS RECEIVED.

*Architectural Photography*, by G. A. T. MIDDLETON, A.R.I.B.A., &c. (London: Hazell, Watson, and Viney, Ltd., Creed-lane, Ludgate Hill), is a small treatise on this subject, being a series of "practical lessons and suggestions for amateurs," which appeared in the *Amateur Photographer*. A great many young architects and tourists will find Mr. Middleton's instructions and advice all they need. Architecture hitherto has been rather shunned by the photographer, for the simple reason that unless care is taken to insure a good position for the camera and the right focus, and to obtain proper light and shadow on the building, the result is vexatious. Photographs of interiors are generally doomed to failure. A point of view is selected to avoid glare of light, and to get in all that is possible, with the result that the effect is disappointing. We have seen many church interiors, for instance, which show an uninteresting west view or a long vista of vault and arcade, taken centrally, one side in hopeless gloom, but the main features of the interior are left out. A diagonal view, as Mr. Middleton says, is often to be preferred. Pews, of course, are abominations for architectural effects, and wide-angle views are unnatural. Many useful hints and photographic examples are given, and the book is a useful introduction to the subject. Some of the street views are interesting examples of the art.—*Sanitary Engineering*, by W. PAUL GERHARD, C.E. (New York).—Mr. Gerhard, whose works on sanitary subjects we have often noticed, discusses in this little book the subject of sanitary engineering, a lecture delivered by the author before the Franklin Institute of Philadelphia some time ago. Mr. Gerhard defines sanitary engineering, and describes what ought to be the basis of the sanitary engineer's education. Many practical hints and suggestions are given on a variety of subjects: water supply of cities and dwellings, sewerage, sewage disposal, street pavements, cleansing footways, refuse removal, laying-out cities, and a variety of other

cognate subjects, into which we cannot here enter. Sanitary engineers and students will gain much from the perusal of this work, and of the many requirements of the profession.—*Bell's Cathedral Series: Hereford* (London: George Bell and Sons).—The present monograph has been written by Mr. A. HUGH FISHER, who expresses his indebtedness to the studies by the Rev. Francis Havergal, and Dean Merewether's exhaustive "Statement," published in 1841, and the Rev. H. W. Phillott's "Diocese of Hereford." The building is one of our smaller cathedrals, and was terribly mutilated, in the 18th century, by Bishops Bisse and Egerton, and the arch-vandal James Wyatt, but still contains much interesting work of the Norman, Early English, and Decorated periods. It is inconceivable that until the present day no successful effort has been made to replace, by a more worthy construction, the Carpenter's Gothic stucco-lined west front constructed by Wyatt. The little work before us is illustrated with forty reproductions of photographs and old prints, and also contains a plan. These guide-books, of which the present is the eleventh published, are tersely written, convenient in size and shape, well bound and illustrated, and reasonable in price.—The quarterly issue of the *Essex Review* (Chelmsford: E. Durrant and Co.) contains an illustrated article on "The Essex Marshlands," by F. Caruthers Gould, and also some interesting notes on "The Essex Taylors" (Isaac, Ann, and Jane), by Ewing Ritchie, and an account of Felsted School, a drawing of which, by G. S. Hodgson, forms a frontispiece to this well-edited county journal.—The quarterly *Report of the Palestine Exploration Fund* is freely illustrated with process blocks; the chief features are articles on recent discoveries in Jerusalem by Dr. C. Schick, "The Home of Samuel" by M. Lucien Gautier, and "Hebrew Names in Inscriptions from Babylon" by Theophilus G. Pinches.—*Norton-sub-Hamdon*, in the county of Somerset, by CHARLES TRASK (Taunton: Barnicott and Pearce, Athenæum Press). The author of this volume deals with the parish of Norton, situated in the southern division of Somerset between Crewkerne and Ilchester. The discovery of hut circles on Ham Hill led to the history of the hill. The church is a fine edifice, with a good example of a Somerset tower. Mr. Trask gives an account of the parish, manor, church, rectory and rectors, parish registers, personal matters, and his work is illustrated by maps, photo-views of the entrenchments on Ham Hill, and old houses. The work is of interest to topographers and antiquaries of this part of the country.

The statue by Mr. John Cassidy, of Manchester, of the late Ben Brierley, in front of the museum in Queen's Park, was unveiled on Saturday. The statue is in Portland stone, and is considerably larger than life-size. It represents the dialect writer in modern dress, standing, the left arm raised and the right hanging by his side. In the left hand he holds some leaves of manuscript, and his right hand rests on the papers which he has just put down on a block of stone.

The new reservoir for the Bath Corporation at Monkswold has been finally completed, and now contains 31ft. of water. It has been constructed by Messrs. Neave and Son, under the direction of Mr. W. Fox, C.E.

Mr. Orchardson, R.A., has been intrusted with commission to paint the memorial portrait of Lord Kelvin which it is proposed to place in the library of the Royal Society at Burlington House.

The Crosthwaite Schools, Keswick, are being warmed and ventilated by means of Shorland's patent Manchester grates, the same being supplied by Messrs. E. H. Shorland and Brother, of Manchester.

The west window for Hawarden Church, to be erected by the members of the Gladstone family to perpetuate Mr. and Mrs. Gladstone's long and happy connection with Hawarden, is approaching completion, and will soon be placed in position. The subject will be the Nativity, from the designs of Sir Edward Burne-Jones.

The twelfth annual dinner of the Auctioneers' Institute of the United Kingdom will take place at the Hotel Cecil, London, on Friday in next week, May 13th, under the presidency of Mr. James F. Field.

The scheme of the Blackpool Sea-water Company, for the erection of a pier at the north end of Blackpool, and the provision of additional pumping facilities in connection with it, was rejected on Friday by a committee of the House of Lords.

## OBITUARY.

MR. PHILIP HERMOGENES CALDERON, R.A., the Keeper of the Royal Academy, died on Saturday from complications following repeated attacks of influenza. Calderon was born, of Spanish parentage, at Poitiers in 1833, and was trained as an artist in Paris and London. He soon came to the front, devoting himself to popular *genre* subjects, and became an A.R.A., at 31, while at the Paris exhibition of 1867 he obtained the first medal given to English artists. In the same year he became a full Academician, and in 1878 he obtained a first-class medal in Paris and the ribbon of the Legion of Honour. Among chief works are his diploma picture "Whither?" an "Enone," and the "Aphrodite," first shown at the Grosvenor Gallery. In 1887 Mr. Calderon was elected Keeper of the Royal Academy in succession to Mr. F. R. Pickersgill. The keeper has a house within the Academy precincts, and is the official head of the schools. From the period of his election he found less time for painting, and of late years he did not often exhibit. One of his sons—Mr. Frank Calderon—is well known as a painter, chiefly of animal subjects.

MR. CHARLES GREEN, one of the most popular members of the Royal Institute of Water-Colour Painters, died on Sunday last at his residence at Hampstead. Born in 1840, he learnt his art at one of the Newman-street studios, and afterwards from Mr. J. W. Whympers. He early made his mark as an illustrator, became a member of the Institute when it was still housed in Pall Mall, and was one of the most energetic of those who brought about its great development when it moved to Piccadilly. Mr. Green was an authority on Georgian costume and furniture, and will best be remembered as the humorous and accomplished illustrator of Dickens's creations.

MR. NATHANIEL TERTIUS LAWRENCE, the head of the firm of Lawrence, Graham, and Co., solicitors, of 6, New-square, Lincoln's Inn, which, under varying names, has been in existence from the 16th century, died on Friday evening at his town residence, 44, Westbourne-terrace. He was one of the oldest solicitors in practice in London, having been admitted in Hilary Term, 1848. On all questions relating to the transfer of land he was a leading authority in the profession, as for many years he devoted much labour and attention to the subject. He assisted in drafting the Conveyancing Acts of 1881 and 1882, the Settled Land Acts from 1882 to 1887, as well as other Acts of Parliament respecting land transfer.

## CHIPS.

The formal opening of a new central school for Fitzlochry took place on Monday. The building, which is one story in height, contains accommodation for 620 pupils, and has cost about £6,000.

The date of the opening of the Exhibition of Works of the French School at the Guildhall Art Gallery is now fixed for Saturday, June 4, its postponement to that date having been necessitated by the ill-health of Mr. Temple, the director of the Gallery.

The Lymington (Hants) Board of Guardians have been notified of the approval by the Local Government Board of the proposed extensions and alterations at the workhouse, for which plans were prepared by Mr. I. Pym Jones, architect, of Lymington.

The interesting old tower of SS. Cattwg and Illyd's Church, Neath Valley, Glamorganshire, is about to be restored, under the supervision of Mr. C. B. Fowler, F.R.I.B.A., of Cardiff. The battlements were bodily taken down some 30 years ago, and an unsightly erection put up above corbel table. It is intended to remove this and rebuild the upper portion on the old lines of the towers of the district. It is also contemplated to add three new bells to the existing three, making a peal of six. Mr. W. A. James, of Cowbridge, is the contractor who has been intrusted with the work.

A fund is being raised for assisting the widows, orphans, and relatives of the workmen killed and those more or less disabled by the collapse of the concrete roof at Abbey Mansions, at the corner of Orchard and Victoria-streets. As at present ascertained, seven wives, four parents, 16 orphans, and ten other children of various ages have to be relieved or provided for. It is believed that not less than £3,000 will be required, and towards this about £300 only has been as yet promised. The hon. secretary is Mr. H. H. Montague Smith, 28, Victoria-street, Westminster.

## Building Intelligence.

**ACTON.**—Mrs. Creighton, who was accompanied by the Bishop of London, opened, on Wednesday the Passmore Edwards Acton Jubilee Cottage Hospital, situated in Gunnersbury-lane. With the hospital are combined a nursing institute and invalid kitchen. The building has been built from plans by Mr. Charles Bell, F.R.I.B.A., at the expense of Mr. J. Passmore Edwards, at a cost of £2,500, and Lord and Mr. Leopold de Rothschild gave the site. About £1,300 has been contributed in the district for fittings, &c. The hospital consists mainly of a ground-floor story. The chief wards are at each side, one for males and the other for females, each containing four beds and a cot. Adjoining each there is a separate ward for one bed, with the necessary offices; there is a room for the matron, a day-room for nurses, and dispensary. Above are seven apartments available for bedrooms, or as special rooms for patients.

**BIRMINGHAM.**—The Hen and Chickens Hotel and Café is in course of erection in New-street, between the Grammar School and Lloyds' Bank. The building, which, with its equipment, has cost £20,000, rises 60ft. above the street level, while the floor of the sub-basement is 25ft. below. The site has a frontage of 48ft. and a depth of 50ft., with an extension of 15ft. under the school premises for the sub-basement. The building rises to a height of five stories and a mansard. The architect is Mr. J. A. Chatwin, and Messrs. James Moffatt and Son are the builders. The facing materials are Aberdeen granite and red terracotta, and the treatment is a development of the Tudor style. A feature of the hotel is an octagonal corner tower, which rises from the level of the first floor on a splayed pier of polished Aberdeen granite, is broken by a series of oriel windows, and is surmounted by a short spire. The upper portion of the façade towards the street is broken by a central series of projecting oriel windows, terminating with a gable in front of the high-pitched roof. The hotel proper commences on the first floor, where are the commercial-room and the drawing-room. Behind is the coffee-room, while farther back are a smoke-room, serving-room, and lavatories. The second, third, and fourth floors contain the visitors' bedrooms, 48 in all, and each containing a fireplace. In the mansard are sitting-rooms and dormitories for the staff. The main staircase is of granite, with a wrought-iron balustrade, and it is lighted by windows of cathedral glass. The artificial lighting throughout the hotel is by electricity, from the mains of the Electric Supply Company, and the building is ventilated by exhaust-fans, driven by electricity, which also supplies the power for working the lift, &c.

**CARDIFF.**—In the sanctuary of St. Peter's Roman Catholic Church, Cardiff, through the generosity of the Marquis of Bute, the old wooden rood-screen has been replaced by a screen of Caen stone. The screen requires for its completion the crucifix with the accompanying figures of the Mother of Sorrows and of St. John, three large statues of the patron saints of the church, and four smaller statues of the patrons of England, Scotland, Ireland, and Wales. There are four slender buttressed piers with face shafts and canopied niches resting on moulded bases of Pennant stone, and from these there spread three arches of Caen stone. These arches spring from the caps of the clustered side-shafts, which are of polished African marble, and springing from the piers between the arches gablets of Caen stone with flowing tracery extend over their cornices. Each gablet terminates in a pedestal, that of the main arch being for the rood, and those of the side arches for the Mater Dolorosa and St. John. When the rood, which is to be 8ft. in height, is supplied, the structure at its highest point will stand 38ft. above the floor of the nave. Its width is 23ft. Below the caps of each of the gablets the carved and bracketed finials of the crocketed arch labels are also surmounted by pedestals to bear statues of the patron saints of the church. The cusps of the arch mouldings looking east and west are furnished with double sets of carved heads representing the Apostles and certain saints. The design is in Late Gothic, and the architect is Mr. Williams Gardner, of Newport, Mon., the contractor being Mr. James Pearse, Great Brunswick-street, Dublin.

**SANDHOE, NORTHUMBERLAND.**—Sandhoe House, at one time the seat of the late Sir Rowland

Stanley Errington, is to be occupied in the course of a few weeks by its present owner, Col. Hornby, and the fabric, which is mainly of the Elizabethan period, is now undergoing extensive alterations and repairs. It has been unoccupied for the last five or six years, its last tenant being the late Hugh Fenwick, and the work of putting it in order for the new tenant has been intrusted to Mr. E. Darlington, of Hexham, the architects being Messrs. Jos. Potts and Sons, of Sunderland. The theatre or ballroom, which comprised one wing of the building, has been entirely demolished, as has also the brewhouse, which formed another wing of the building. New fireplaces have been inserted in all the rooms—some 40 or 50 in number; all the floors on the ground floor have been relaid, and sundry other alterations and improvements have been carried out. The lawns, terraces, and fancy flower plots, which were at one time noted for their unrivalled beauty, are likewise being well attended to.

**WOMBWELL.**—The first section, consisting of nave and aisles of the new parish church of St. Mary, Wombwell, was consecrated by the Bishop of Beverley last week. It occupies the site of the old church, which was in the last state of decay. The new nave is 90ft. long, with a clear width across of 53ft., and the height of the roof is 40ft. The aisles are divided from the nave by arches of Bath stone, and there are large clerestory windows. In the chancel arch an oak altar has been placed with altar dorsal and hangings, and at either side the arms of the Archbishop and See of York are carved. On the north stands a pulpit, having a vase of Dove marble and a marble capping. In the three front panels the Transfiguration of our Lord is carved. Mr. C. M. Hatfield was the designer, and Messrs. Boulton and Sons, of Cheltenham, executed the work. The same firm also carved the font, which, with the oak altar, is also a special gift. The church floors are laid with wood blocks, and the aisles are paved with marble mosaic. The church is designed in the style of the South Yorkshire churches erected at the close of the 15th century. The building is warmed by the low-pressure hot-water system, by Haden, of Manchester. The contractor is Mr. George Webster, of Sheffield, and the architects were Mr. Charles Hadfield and Mr. A. R. Garland, of the same city. Mr. F. Cook, of London, has acted as clerk of the works.

The bridges committee of Glasgow Town Council have resolved to recommend the erection of a new swing bridge across the Clyde at Oatlands Ferry, at a cost of £15,000.

A joiner named Henry Pratley, of Harrow-road, won a verdict for £85 under the Employers' Liability Act at Marylebone County-court, on Monday, for the loss of three fingers, caused by the negligence of a foreman at the works of Messrs. Godson and Sons, builders, of Kilburn, while working a circular saw.

The small church at Yiewsley, designed 30 years ago by the late Sir Gilbert Scott, consisting of a nave, apsidal chancel, and vestries, being inadequate to present requirements, has been converted into a north aisle and chapel attached to a large new nave and chancel erected on the north side of the original fabric. Messrs. Nicholson and Corlette are the architects of the new work, which has been carried out by Messrs. Fasnidge and Son, of Uxbridge, the builders of the original fabric. The cost has been under £4,000.

A faculty has been granted for restoring the parish church of Trimley St. Martin, near Felixstowe. The works will include the erection of a new roof of pitch-pine, the removal of a lath-and-plaster ceiling, and the erection of a new chancel in place of one of deal, painted to imitate marble, and erected by the parish carpenter 18 years ago.

The Princess Louise, Marchioness of Lorne, has designed and will superintend the execution of a statue of the Queen for the Manchester Cathedral. The statue, which is life-size, will be placed over the western porch. It is intended as a memento of the visit of her Majesty to the Art Treasures Exhibition in Manchester in 1857, and it represents the Queen simply robed, in accordance with her age at that time, and with sceptre in hand. The western entrance and porch of the cathedral are now practically completed, and the necessary funds have been fully subscribed.

It is announced from Athens that Mr. F. C. Penrose, F.R.S., the distinguished past surveyor of St. Paul's, is again on a visit to that city. Mr. Penrose, who is now in his 83rd year, is superintending the works in progress for the better security of the Parthenon.

## Engineering Notes.

**INSTITUTION OF CIVIL ENGINEERS.**—The council of this institution have made the following awards for papers read and discussed before the institution during the past session:—Watt Medals and Premiums to Messrs. H. L. Callendar and J. T. Nicolson; a Telford Medal and Premium to Mr. A. H. Preece; George Stephenson Medals and Premiums to Messrs. Whately Eliot and W. O. E. Meade-King, a Crampton Prize to Mr. E. W. Anderson; Telford Premiums to Messrs. L. B. Atkinson, Henry Fowler, and W. L. Strange. The presentation of these awards, together with those for papers which have not been subject to discussion and will be announced later, will take place at the inaugural meeting of next session.

**THE PROPOSED NEW BRIDGE AT KEW.**—A Select Committee of the House of Commons unanimously approved on Tuesday the preamble of the Kew Bridge and Approaches Bill, which provides for the erection of a new bridge at Kew in place of the existing one. The only opposition was from the West Middlesex Water Company, which claimed the continuance of their present statutory power (as yet never exercised) to carry their mains across the bridge. The committee decided that a clause prohibiting the company from carrying their pipes across the new bridge without the consent of the Middlesex and Surrey County Councils should be retained; but they directed certain new clauses to be prepared to protect the company's mains. The present stone bridge was erected in 1788. It is unfortunately very narrow, being only 18ft. wide in the roadway and 3ft. footway on each side. There is also a very dangerous gradient on the Middlesex side of 1 in 15, and on the Surrey side of 1 in 17, and the seven arches with six piers in the river are an impediment to the increasing river traffic. The new bridge has been designed by Sir J. Wolfe Barry and his partner (Mr. Chas. A. Brereton). It will be a stone structure of three arches, with two piers in the river, and will be 48ft. wide, with a 30ft. roadway, and a footpath of 9ft. wide on each side.

### CHIPS.

The town council of Stirling have appointed Mr. Andrew H. Gondie, assistant master of works at Paisley, as master of works for the burgh in the stead of Mr. F. C. Holmes, who has been appointed burgh surveyor of Govan.

The Mersey Docks Board, at their last meeting, decided to construct a passage of 90ft. wide, with gates leading to the proposed new branch dock, on the site of the southern portion of the Sandon Dock, at an estimated cost of £12,000. It was also decided to widen certain sheds at the Victoria Dock at an estimated cost of £1,350.

The sale of the Renton collection of modern pictures and water-colour drawings at Christie's, on Saturday, realised about 22,000 guineas. The "Order of Release," by Millais, fetched 5,000 guineas, the purchaser being Mr. Henry Tate, who proposes to add it to the collection in the National Gallery of British Art; the "Black Brunswick," by the same artist, realised 2,650 guineas; while "Afternoon Tea," also by Millais, was sold for 1,300 guineas.

The foundation-stone of the chapels at the new cemetery which is being formed at Brandwood End, King's Norton, by the King's Norton Rural District Council, was laid on Saturday afternoon. Mr. F. Brewin Holmes is the architect, and Mr. E. J. Charles the builder. The cemetery covers an area of 31 acres, of which 13 acres are now being laid out. The total cost of the undertaking is £16,000.

The trustees of the Chantry Bequest have purchased Mr. Melton Fisher's "In Realms of Fancy," Mr. Ralph Peacock's "Ethel," Mr. Herbert Draper's "Lament for Icarus," Mr. Glendinning's "Haymaking," a water-colour; and Mr. Yeend King's "Milking-Time."

The foundation-stone of new public baths at Grangetown, Middlesbrough, was laid on Saturday afternoon. The building will consist of a swimming bath and slipper baths, with the bathman's and caretaker's house above, and a public washhouse and laundry. The slipper baths are the portion now in course of erection, and these will form the central part of the building. The land has been given by Messrs. Bolckow, Vaughan, and Co., and the cost of the building is entirely defrayed by Mr. James Eadie, of Derby. The contract for the whole of the work has been let to Messrs. Bastiman Bros., of Middlesbrough, for £1,736. The architect is Mr. Mitchell Bottomley, of Middlesbrough and Leeds.

CONTENTS.

Building Dangers ... 623  
 Architecture at the Royal Academy.—II. ... 623  
 Pictures at the Royal Academy ... 624  
 Model Specifications.—XI. ... 626  
 The Society of Architects ... 628  
 New Mode of Protecting the Banks of Rivers from Erosion by Water ... 629  
 Steel and Concrete Combinations ... 629  
 Electric Lighting Notes for Architects.—XXII. ... 630  
 The Surveyors' Institution ... 632  
 Museums of the Science and Art Department ... 633  
 Books Received ... 633  
 Obituary ... 633  
 Building Intelligence ... 634  
 Engineering Notes ... 634  
 The Building News Directory ... 1x.  
 Our Illustrations ... 635  
 Competitions ... 635  
 Professional and Trade Societies ... 654  
 Water Supply and Sanitary Matters ... 654  
 Correspondence ... 655  
 Intercommunication ... 656  
 Legal Information ... 656  
 Our Office Table ... 657  
 Meetings for the Ensuing Week ... 658  
 Trade News ... 658  
 List of Competitions Open ... 659  
 List of Tenders Open ... 659  
 Tenders ... 661  
 Latest Prices ... 662

ILLUSTRATIONS.

- MESSRS. BARCLAY AND COMPANY'S BANK, FLEET STREET.—  
 SOLENT YACHT CLUB, YARMOUTH, ISLE OF WIGHT.—  
 COTTAGE HOMES OF THE LINEN AND WOOLLEN DRAPERS' INSTITUTION, MILL HILL.—STUDIES OF ANIMAL LIFE, TREATED FOR DESIGN.—LISEUX CATHEDRAL.

Our Illustrations.

MESSRS. GOSLINGS' BANK.

The new building about to be erected for Messrs. Barclay and Co., Limited, will stand on the site of the premises which have been occupied by the firm of Goslings and Sharpe for some generations past, the latter firm being now amalgamated

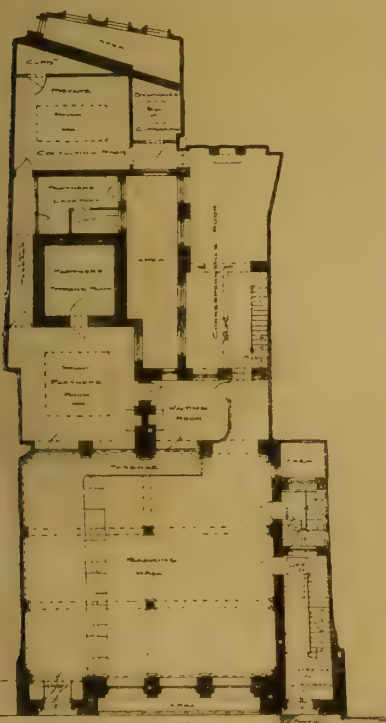

—GROUND FLOOR PLAN—

with Messrs. Barclay and Co. The demolition of the old house and erection of the new building have been rendered necessary by the increase of business since the amalgamation. The accommodation will consist, as indicated by the ground-plan, of a spacious banking hall, of the full width of the site, except for an entrance and staircase for access to the upper floors, together with the usual directors' and waiting-rooms, &c. The first floor will contain a large and light suite of offices, while the two upper floors will be occupied by the bank manager as a residence. The front will be

entirely of Portland stone. The drawing herewith illustrated is now on view at the Royal Academy.

SOLENT YACHT CLUB, YARMOUTH, ISLE OF WIGHT.

The architect of this building, which has been erected for the Solent Yacht Club, is Mr. Aston Webb, F.S.A.

THE COTTAGE HOMES OF THE LINEN AND WOOLLEN DRAPERS' INSTITUTION.

THESE buildings are now in course of erection on the southern slope of Mill Hill, Middlesex, on a beautiful site given by Mr. James O. Marshall. The scheme provides for fifty-four homes for pensioners of the institution, and many firms and private individuals interested in the trade have given one or more of the buildings. The central block contains a large hall with an open-timber roof and an oriel window, a small meeting-room, warden's apartments, &c., and has been built by the Marshall family in memory of the late Mr. James Marshall, of Goldbeaters, Middlesex, and Vere-street, W., and Mr. John Snelgrove and Mr. J. C. Marshall have each erected one of the wings, containing together eight dwellings. The other donors are: Mr. Alfred Brown, J.P., Mr. Wyndham F. Cook, Mr. Fred. Crisp, J.P., Messrs. Hitchcock, Williams, and Co., Mr. Peter R. Jones, Mr. William P. Jones, Mr. Howard Morley, Messrs. I. and R. Morley, Mr. Owen Owen, Mr. M. H. Rackstraw, Mr. J. R. Roberts, J.P., Mr. T. R. Roberts, Messrs. J. Rotherham and Co., Mr. John Scott, J.P., Sir George Williams, and the Smoking Concert Committee. The works are being carried out by a local builder, Mr. William Tout, of Hendon, under the superintendence of the architect, Mr. George Hornblower, A.R.I.B.A., of No. 2, Devonshire-street, Portland-place, W., whose designs were selected in a limited competition. The drawing we illustrate is in this year's Royal Academy Exhibition.

STUDIES IN ANIMAL LIFE, TREATED FOR DESIGN.

CONTINUING our series of plates of Birds and Beasts, drawn with a view to their application to decorative purposes, we to-day publish some clever studies for which a National Silver Medal was awarded last year to Mrs. M. E. Dawson. These include the great-eared owl, the painted quail, the double-spurred francolin, some rabbits, the head of a running hare, the barn owl, and the painted francolin. The several subjects are characteristically handled with skill and appreciation on the part of the artist, so that her studies will not fail to be valued by our artistic readers.

LISEUX CATHEDRAL, FRANCE.

LISEUX has been well termed "the Chester of France," on account of its many and famous old timber houses erected in delightfully quaint streets, picturesquely grouped in rambling irregularity, in the valley of the Orbiquet and Touques. Everyone who can make a visit, of course, to this charming old city, and its buildings are more or less represented in every architect's sketchbook. The former cathedral is a very remarkable and delightful building, perhaps the most interesting specimen of Transitional to be found in the whole of Normandy. In size it has many superiors, and in richness of detail it is excelled by other churches. Its west front is severe in design and simple in its parts. On plan the building takes the form of a Latin cross, enriched by radiating chapels, and over the crossing is a lantern tower of 13th-century date. A simple range of lancet-windows surrounds the building at the clerestory level. The fabric was commenced in 1045, but was burnt in 1136. The rebuilding began in 1141, and was finished some forty years later. Enlargements were made in 1218, but another fire damaged the building in 1226. Seven years after that date the completion of the whole structure was realised. The church, as it stands, is a pure and harmonious example of its time. Against the north wall of the transept are two 12th-century tombs. Behind the sanctuary is the Chapelle de la Vierge; it is paved with ancient gravestones, and was built as an expiatory offering from Bishop Pierre Cauchon, the wicked judge of Jeanne d'Arc, who had been expelled from his former bishopric of Beauvais by his diocesan. Lisieux had a line of bishops of its own, from the 6th century to the present century, when the see was suppressed. Henry II. of England was married to Eleanor of Guyenne in this building. We are indebted to the *American Architect* for the sketch given herewith to-day.

COMPETITIONS.

SOUTHEND.—Mr. J. M. Bryden has made his award as assessor on the competitive designs for the proposed new buildings, consisting of town-hall and corporation offices, fire brigade station, and technical and science schools, with provision for space for the subsequent erection or provision for gymnasium, free library, and police-station and court-room. The successful competitor is Mr. H. T. Hare, associated with Mr. Thomas Davidson, of London. The assessor says that the estimated cost is rather low, but there is little doubt it can be carried out within 10 per cent. of the amount named by Mr. Hare, or about £45,000. The council have postponed definite action until their next meeting.

CHIPS.

In the House of Lords, the Crowhurst, Sidley, and Bexhill Railway Bill has passed the Earl of Morley's Committee.

At Southwark Police-court, on Friday, James Carmichael, builder, of Wandsworth, was summoned for beginning the foundations of a new building without having given seven days' notice to the Bermondsey Vestry. The magistrate fined the defendant £5, with further penalties of 10s. a day for 56 days, and the cost of the summons, making £33 2s. in all.

Giving evidence before the Royal Commission on the London Water Supply, on Monday, Sir A. Arnold, formerly chairman of the London County Council, declared that there was ample scope in that body for undertaking the administration of the water supply. Dr. Shirley Murphy, medical officer of health for the administrative county of London, held that the water-owning authority and the disease-preventing authority ought to be the same. The enteric death-rate of London was at present very low, and the virus was very feeble, but it might become more dangerous and difficult to deal with in future. The Commission adjourned till next Monday.

Mr. William Quarrier's Consumption Hospital at Bridge of Weir being now completed and on the eve of receiving patients, was, on the invitation of the Medical Advisory Board, inspected on Saturday by members of the medical profession in Glasgow and district. The institution is for females, and will accommodate 36 patients. It has cost £25,000, and further extensions are proposed.

The London School of Medicine for Women in Hunter-street, Brunswick-square, W.C., was informally opened on Monday. It has been rebuilt from plans by Mr. J. M. Brydon, F.R.I.B.A., the contractors being Messrs. Holloway Brothers, of Victoria Works, Battersea. We illustrated the new school in our issue of Dec. 17, 1897.

As announced by Sir E. Poynter at the Royal Academy banquet, the portrait of Mr. Gladstone painted in 1879 by Sir John Millais has been presented to the nation by Sir Charles Tennant. Its ultimate destination will probably be the National Portrait Gallery. The portrait was painted for the Duke of Westminster, who sold it during the progress of the disruption of the Liberal party caused by the introduction of its first Home Rule measure. It is at present on view at the West Ham Free Picture Exhibition in the Town Hall, Stratford, which closes to-morrow (Saturday).

In connection with complaints of the nuisance caused by the Brighton refuse destructor, the works committee of the town council have decided that Major Hector Tulloch, R.E., of Victoria-street, Westminster (late chief engineering inspector of the Local Government Board), and Mr. S. H. Terry, M.Inst.C.E., M.Inst. Mechanical Engineers, of Victoria-street, Westminster (formerly an inspector of the Local Government Board), be retained on behalf of the corporation to inspect the destructor and report to the committees whether there are any defects in its construction or working, and, if so, what are the best-known means which can be adopted for preventing any nuisance or annoyance from the works.

In the Queen's Bench on Friday, Miss Jervis Smith, Brooksford Hall, Doveridge, near Darby, obtained £555 damages and costs against a Weybridge builder named Greenfield, in respect of a broken arm sustained by the fall of a greenhouse cistern, which defendant had fixed at her aunt's house. Mr. Justice Day observed that there had been gross and childish negligence on the part of the defendant.

During the past week no property of importance was offered at the Tokenhouse Yard Mart; but there was a keen demand for ordinary investments. Several lots of building land were offered, one estate of eleven acres in a north-east suburb selling at £700 per acre. The total sales amounted to £157,200, which is £105,525 in excess of the corresponding week last year.

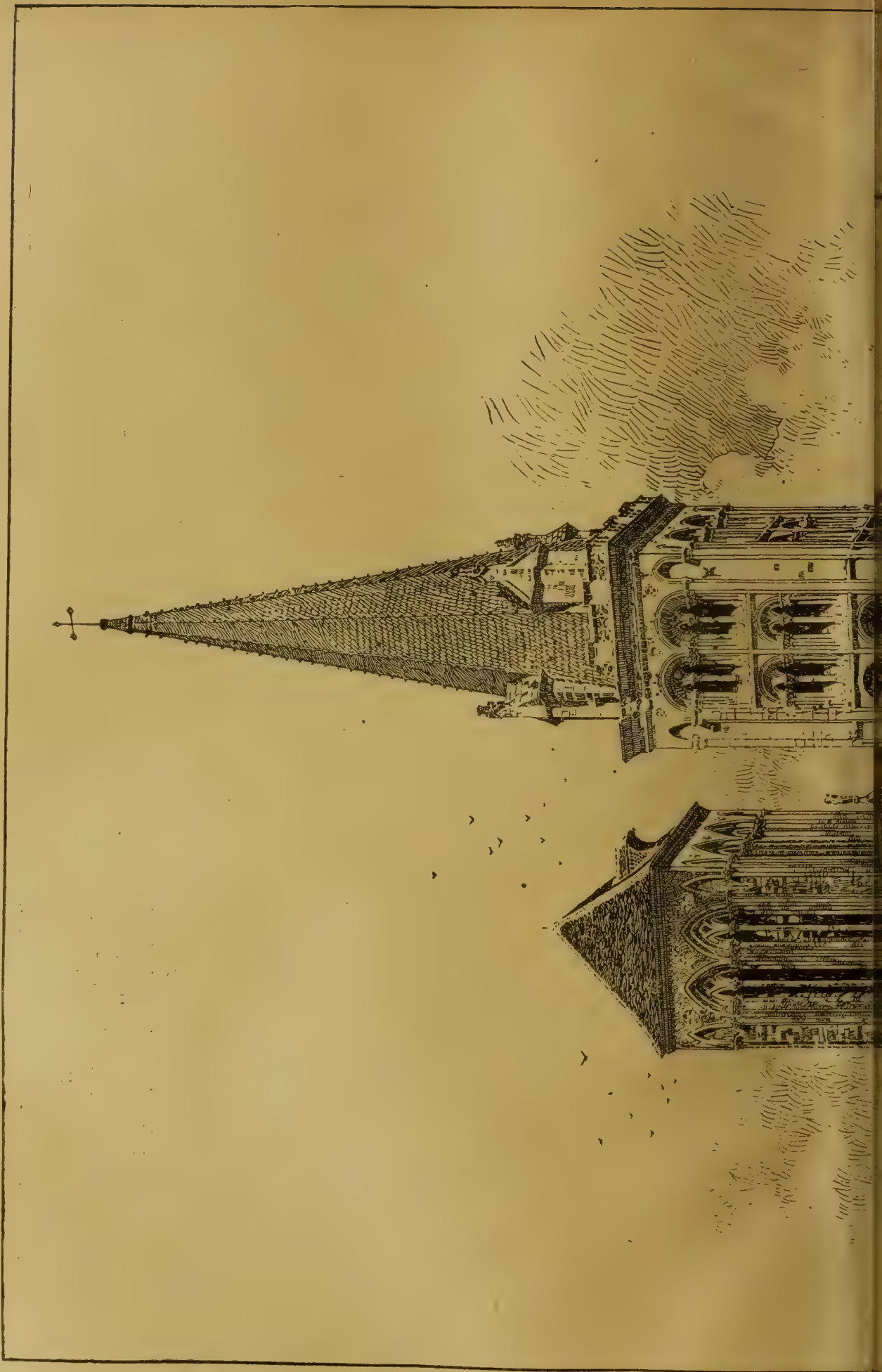

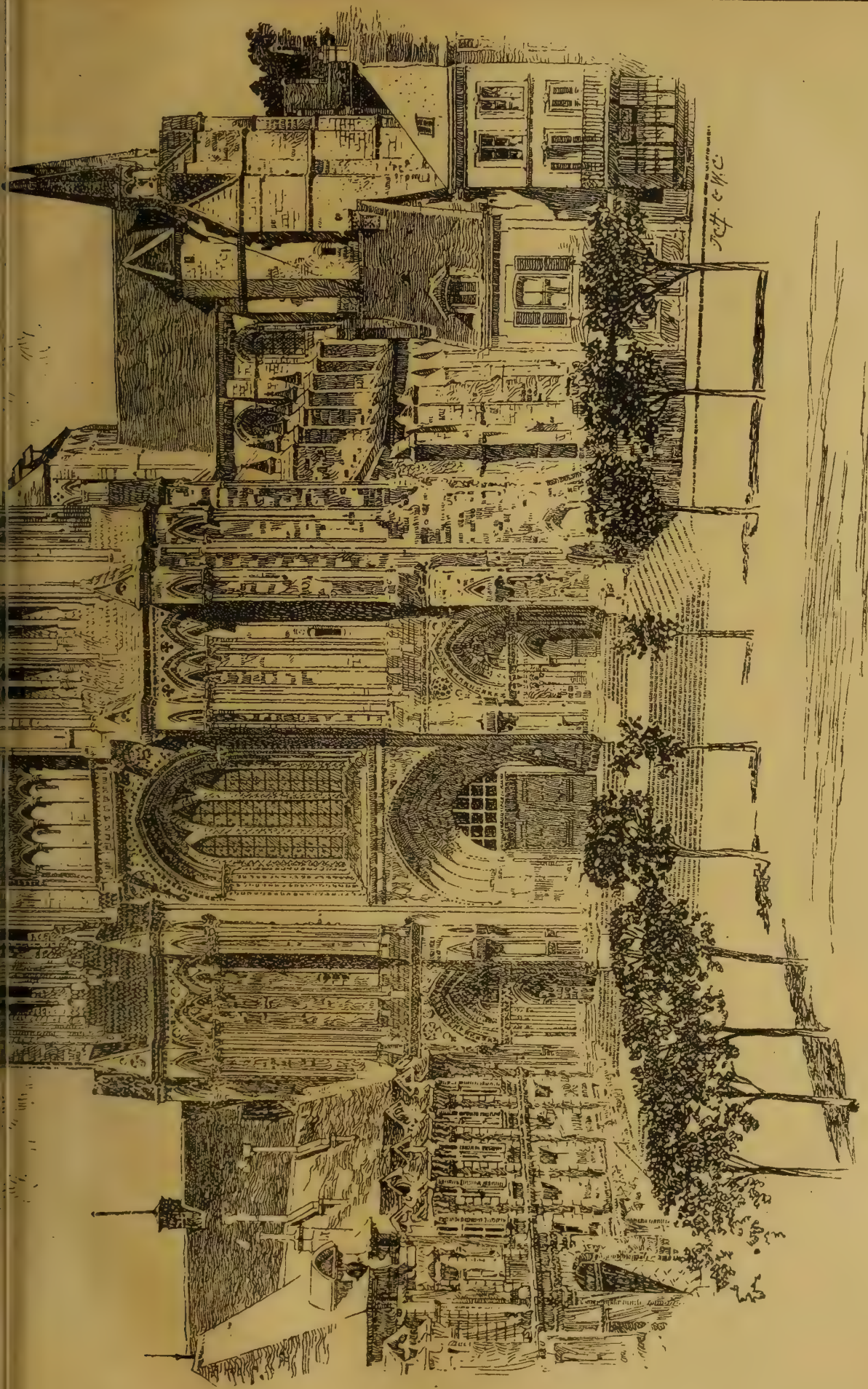

•• LISIEUX • CATHEDRAL • FRANCE ••

### PROFESSIONAL AND TRADE SOCIETIES.

**BRITISH ASSOCIATION OF WATERWORKS ENGINEERS.**—The annual meeting of this body will be held at Southampton on May 24 and three following days. On Tuesday, May 24, the proceedings to be opened by the Mayor welcoming the association to Southampton. A business meeting will follow, and many practical papers will be read. On Wednesday, May 25, a business meeting will be held in the morning. After luncheon, the members will visit the works of the South Hants Waterworks Company (wells, headings, pumping-station, and softening works on the subsiding system). The annual dinner takes place in the evening. On Thursday, May 26, business in the morning. After luncheon, a visit will be paid the Southampton waterworks. On Friday, May 27, the members will visit the Portsmouth waterworks and the Gosport Waterworks.

**GLASGOW MASTER WRIGHTS' ASSOCIATION.**—The thirteenth annual meeting of this association was held on Thursday evening in last week, within the Building Trades' Exchange, Mr. Hugh M'Taggart, president, in the chair. The directors' report and financial statement were submitted by the secretary, Mr. James L. Selkirk, C.A. The report stated the association was now stronger in point of numbers and influence than ever it had been before, and that the directors had been increasingly serviceable to the members in advising them on questions of difficulty with architects and proprietors. The relations with the operatives continue to be satisfactory. The financial statement showed a credit balance of £38 15s. 11d. Office-bearers were appointed, Mr. James Ferguson (Messrs. Ferguson and Anderson) being elected president; and Mr. James L. Selkirk, C.A., re-elected secretary and treasurer. Mr. Joseph Somerville, City Saw Mills, thereafter read a paper on the structure, growth, and description of some of the chief timber-yielding coniferae. Mr. Somerville emphasised the importance of a scientific knowledge of the structure of timber in a healthy condition, in order to prevent or cure the diseases—such as dry rot, &c.—to which it was subject. The difference between the pines, spruces, and firs was described. Mr. Somerville suggested a theory, which seemed to be borne out by experience, as to the leaves—namely, that the greater the number of leaves in a bundle the tree had, the wood from that tree would be better and more durable than that from those with few leaves in a bundle, or solitary leaves. He instanced the larch, which had a great many leaves in a bundle, as a good, durable wood in comparison with the Scots pine, with two, or the silver fir, with solitary leaves. The trees producing the chief timber of commerce were then described in detail, including the Scots pine, the Canadian yellow pine, pitch-pine, Baltic whitewood, Oregon pine, Californian redwood, and Kauri pine. The paper was illustrated with diagrams, microscopic sections, and specimens of the wood and leaves of the different coniferae.

**ROYAL INSTITUTE OF BRITISH ARCHITECTS.**—The annual general meeting of the Institute was held on Monday night, at 9, Conduit-street, W., the chair being occupied by Mr. H. L. Florence, vice-president, and the total attendance numbering just twenty-four. The gist of the annual report, which formed the main feature of the discussion, and was eventually adopted, was published by us last week (p. 596). The accounts showed that the balance of income over expenditure during 1897 had been £1,116 11s. 1d. Prior to the general meeting a special meeting was held for the purpose of confirming resolutions relative to some alterations in the by-laws passed at the meeting held on Monday, April 18th, and detailed in our issue of the 22nd ult. (p. 553). It was resolved to admit to alliance, under by-laws 77-81, the Aberdeen Society of Architects.

The Duke of Norfolk has sold The Farm, his Sheffield residence, and a large portion of his grounds, to the Midland Railway Company, the property being required for the enlargement of the Midland station.

A convalescent home for workpeople was opened at Horsforth, near Leeds, by the Lord Mayor of the latter city on Saturday. The building consists of two semidetached stone-faced villas, transformed to the new purpose from plans by Mr. Walter A. Hobson, of Leeds. Accommodation is provided for 32 patients and an administration staff.

### WATER SUPPLY AND SANITARY MATTERS.

**MANCHESTER SEWAGE TREATMENT.**—The Rivers Committee of the City Council met on Friday to decide what sum should be borrowed for treating the city sewage at Davyhulme on the bacterial system. It was agreed to ask the sanction of the Local Government Board to the borrowing of £160,000. This sum, it is estimated, will be required for 37 acres of bacteria beds and the purchase of the necessary land for aeration purposes.

**SOUTHWARK AND VAUXHALL WATER BILL.**—The Select Committee of the House of Commons engaged in the consideration of the scheme of the Southwark and Vauxhall Waterworks Company for the construction of new storage reservoirs between Sunbury and Molesey Locks, for the abstraction of additional water from the river Thames, for the raising of new capital, and for other purposes, resumed their inquiry on Monday. Mr. James William Restler, C.E., said he had been engineer to the Southwark and Vauxhall Waterworks Company for 15 years. He asserted that the bulk of their water was taken from the Thames at Hampton, and a small quantity from wells at Streatham. In 1882 the company commenced at their own instance to give a constant supply of water to their district, and now 93.68 per cent. was under a constant supply. The proposed reservoirs would contain 1,076,000,000 gallons, or storage for 120 days. The total storage capacity of the company's works would be 1,539,000,000, and calculating their supply at 40 gallons per head per day, they would have a supply for 120 days up to the year 1911. The company were now asking for power to supply 45 million gallons per day, which was absolutely necessary to enable them to cover the daily demand of 43 million gallons. The company were not to be allowed to take any water for their extra supply unless 180,000,000 gallons were flowing past Molesey Lock. That they proposed should be the minimum. If the flow fell below that they proposed that they should equalise their supply by taking the water from the storage reservoirs. The 180,000,000 gallons flowing past Molesey would give a flow of 200,000,000 gallons at Teddington. To fix the point of gauging at Penton Hook instead of at Molesey would be to allow something like 53,000,000 gallons of water to pass the company's intake per day uselessly. Mr. R. S. Middleton, C.E., also gave evidence. Mr. James Mansergh, C.E., of Westminster, who was examined on Tuesday, stated that he had been a member of the Royal Commission over which Lord Balfour of Burleigh had presided, to inquire into the Metropolitan water supply in 1892 and 1893. He had designed and was carrying out the largest waterworks in this country—the great Birmingham scheme for bringing water from the Welsh hills to Birmingham. He had considered the proposed works and approved of them. The only important point was the quantity of water flowing over the weir at Teddington, and 200,000,000 gallons in his view was an ample flow at that point. There was nothing in the Bill contrary to the spirit of the report of Lord Balfour of Burleigh's Commission. In reply to the chairman, Mr. Johnson Ferguson, witness said he thought that the Grand Junction, the Lambeth Company and the other companies would have to come to Parliament in a few years for similar powers to those the Southwark and Vauxhall Company was now applying for. There should be an arrangement by which the water should be measured, so as to see that no one company took more from the river than its fair share. Mr. George Henry Hill, C.E., who was also a member of Lord Balfour of Burleigh's Commission, and who had carried out the Manchester and Glasgow water schemes, gave similar evidence.

**STAINES RESERVOIRS.**—The initial step towards carrying out the powers conferred in 1896 upon the New River, the West Middlesex, and Grand Junction Water Companies for the construction of reservoirs for their joint use at Staines, was taken on Saturday afternoon, when Mr. E. Boulnois, M.P., chairman of the joint committee, cut the first sod of the new works. Each company is practically responsible for one-third of the cost, and has a right to one-third of the additional supply, amounting to 35,000,000 gallons daily, or to 45,000,000 gallons under emergency. The maximum quantity allowed to be taken from the river for supply and for filling the reservoirs is restricted to 100,000,000 gallons in any one day of twenty-four hours. The committee can only take at Bell the surplus water above a flow of 265,000,000 gallons daily, which is equivalent to 364,000,000 gallons daily at Teddington, and this, after providing for the statutory quantity of 130,000,000 gallons which the companies have a right to take between Sunbury and Molesey, leaves 234,000,000 gallons daily to flow at Teddington. The intake from the Thames is to be on the Middlesex bank, about 300 yards below Bell Weir, and here sluices and a sluice-house will be constructed. The first length of the conduit will be closed for about 350 yards, and will be siphoned under the Colne brook, where it will become open. It will pass under the Great Western

and London and South-Western Railways and the Wyzardisbury river through siphons, skirt Staines Moor, be again siphoned under the Colne, then run between the Linoleum Works and Hammond's Farm to the pumping station, which is to be situated near the Billet Bridge which carries the London road over the river Ash. The pumping machinery will consist of five triple-expansion surface-condensing Worthington pumping engines, each capable of delivering 16,000,000 gallons daily. The water will be delivered into the reservoirs through two riveted steel mains 6ft. 3in. diameter, joining into a steel pipe 8ft. 8in. diameter near the reservoir. The works have been designed by Messrs. Hunter and Middleton, Victoria-street, S.W., and will be carried out by Messrs. John Aird and Sons.

### CHIPS.

The Brighton Sanitary Committee have instructed the borough surveyor to bring up amended plans and estimates for the artisan's houses to be erected on the Lewes-road site.

A disastrous fire occurred at the extensive timber yard of E. and D. Maginnis, contractors, Bolton, on Saturday morning. The outbreak originated in a stove, and the flames spread rapidly to the boiler-house, engine-room, and store department, all being wrecked. A large portion of the works were saved, also valuable adjoining property; still, the damages are heavy, much stock being destroyed.

The Brighton borough engineer and surveyor has submitted to the works committee of the corporation a report on Volk's electric tramway. It will be necessary to reconstruct one portion of the line on piles to the southward of the widened Madeira-road, the cost of this to Mr. Volk being estimated at £1,500. The committee consider this a reasonable opportunity for re-considering the existing arrangement between Mr. Volk and the corporation, and recommend the grant to Mr. Volk, at a yearly rental of £120, of a lease of the arch he occupies and a license for his line for a period of 21 years, the line, rolling stock, and plant to become the property of the corporation at the end of the twenty-one years.

A meeting of the Chapter of St. Ninan's Cathedral, Perth, was held in the cathedral on Friday. It was agreed to go on with the larger scheme for improving the cathedral, with certain modifications. The Bishop of St. Andrew's announced that the subscriptions already received for the improvement scheme amounted to almost £35,000, which is half the sum which the improvements are estimated to cost.

At the London Consistory Court on Friday, a faculty was granted to the vicar and churchwardens of Hendon to remove the gallery built in 1827 over the north-east chapel of that church and for the erection of a stained-glass memorial window in the chapel. A faculty was also granted to the vicar and churchwardens of Christ Church, Chelsea, to extend the chancel, to build a choir-vestry, and a clergy-vestry and organ-chamber, to take into the church a space at present occupied by a porch, to construct two new porches elsewhere, to extend the front of the church, and to alter the galleries by lowering the front seats. There is also a proposal to build a church-room on land adjoining the church, given by Earl Cadogan. The alterations will cost from £3,000 to £5,000, of which £2,500 is already in hand.

An inquiry was held by Colonel J. T. Marsh, R.E., Local Government Board inspector, at St. Helen's Town-hall, yesterday, into an application by the corporation for sanction to borrow £13,000 for the provision of refuse-destructor works at Boundary-road, in close proximity to the residential part of the town. The matter had excited considerable controversy in the town, and the scheme was opposed by many property owners and ratepayers. Evidence was given by Mr. G. J. C. Broom (borough engineer) that the site was the best they could acquire in the borough for destructor works, and he estimated the saving in carting alone to the corporation at £700 per year.

The Quay Chapel, Woodbridge, East Suffolk, was reopened, after restoration, on Wednesday week. Pitch-pine benches have taken the place of the old-fashioned pews; the pulpit, which had been occupied by, among others, Rowland Hill, has been superseded by a Gothic rostrum of varnished pitch-pine. An entirely new floor has been laid, and the ceiling ornamented and strengthened with moulded ribs. The old-fashioned small square sash windows have been replaced with leaded lights in pale tinted cathedral glass and ruby margin formed in Gothic heads. The walls are covered with sage green, relieved with terracotta stencil border. New entrance doors have been hung. The system of lighting has been entirely rearranged, and incandescent burners have been added. The galleries have also been re-benched. The organ has been repaired by Messrs. Bishop, of London. The cost of the alterations, which were carried out by Mr. W. Ingram Smith, has been about £500.





GENERAL PLAN

100 50 0 100 200

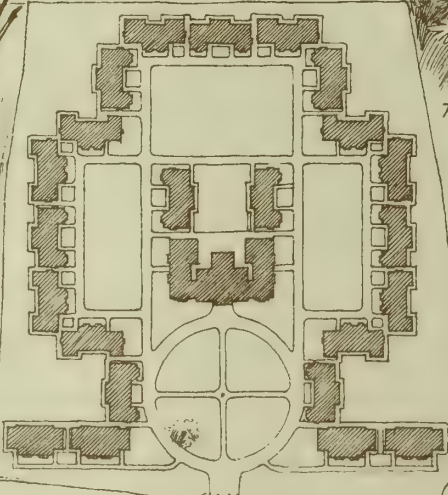

HAMMERS LANE

THE COTTAGE  
 HOMES OF THE  
 LINEN AND WOOLLEN  
 DRAPERS' INSTITUTION  
 MILL HILL MIDDLESEX  
 GEORGE HORNBLLOWER ARIBA  
 ARCHITECT



MAY. 6, 1898



FRANK  
GREEN, DELT.  
1898.





MESSRS BARCLAY & COMPANY'S BANK, FLEET STREET.

(LATE GOSLING & SHARPE)

ARTHUR C. BLOMFIELD, ARCHITECT.

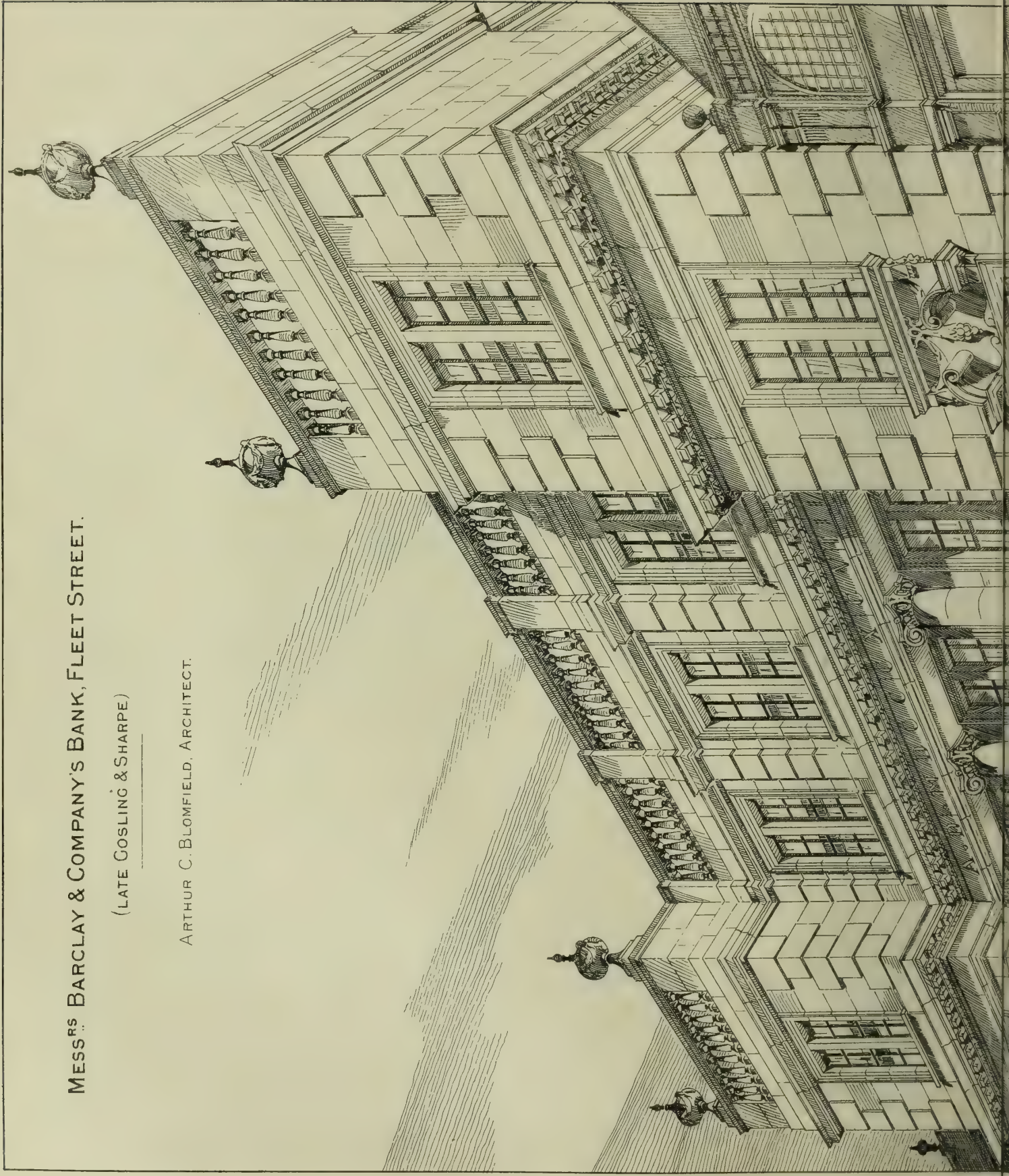

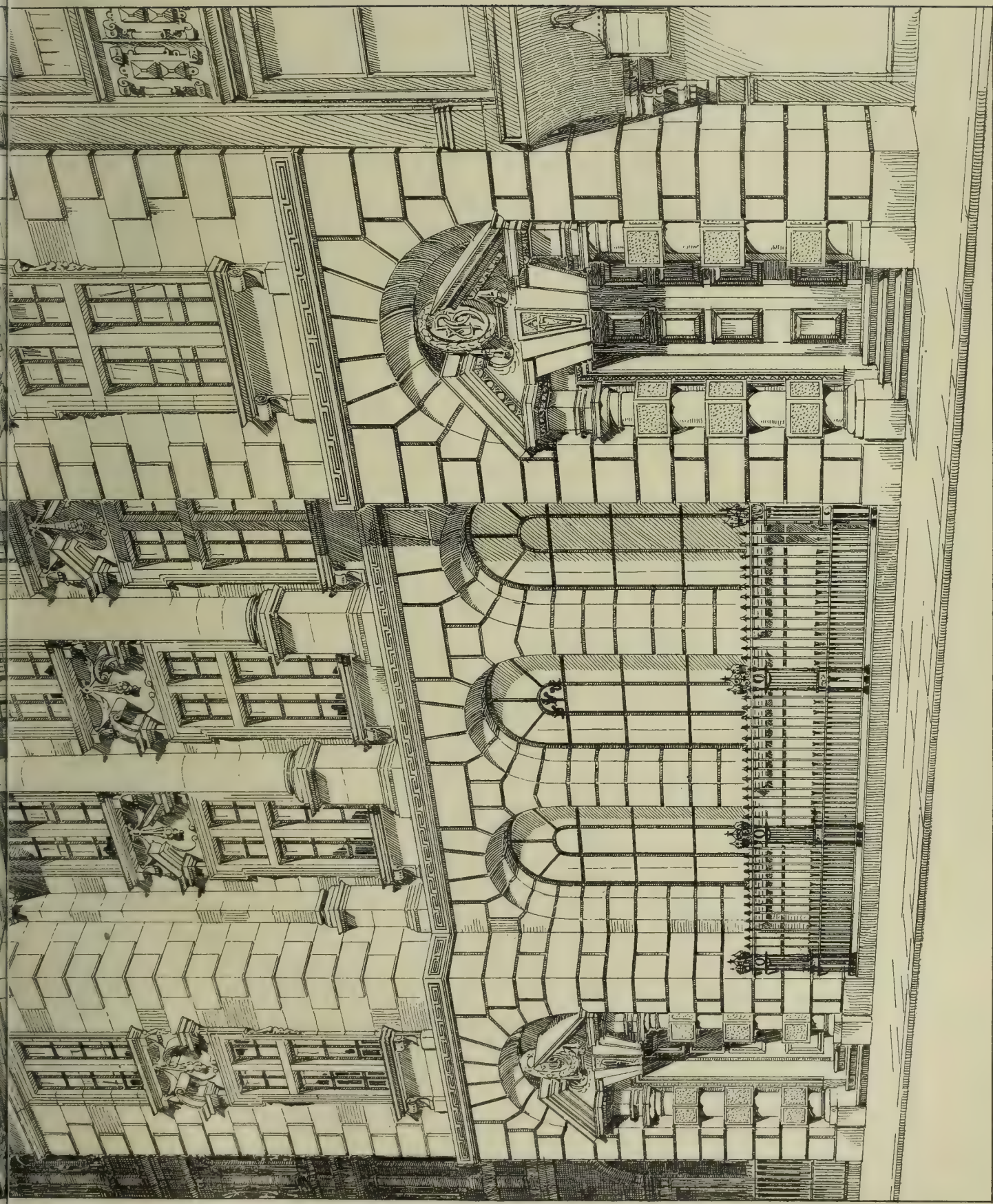







SOLENT YACHT CLUB, Y

ASTON WEBB, P



MAY. 6. 1898



Photo-Lithographed & Printed by James Akerman 6, Queen Square, W.C.

MOUTH, ISLE OF WIGHT,

A., ARCHITECT.







HEAD OF RUNNING HARE.



RABBIT.



BARN OWL



Foot of Barn Owl

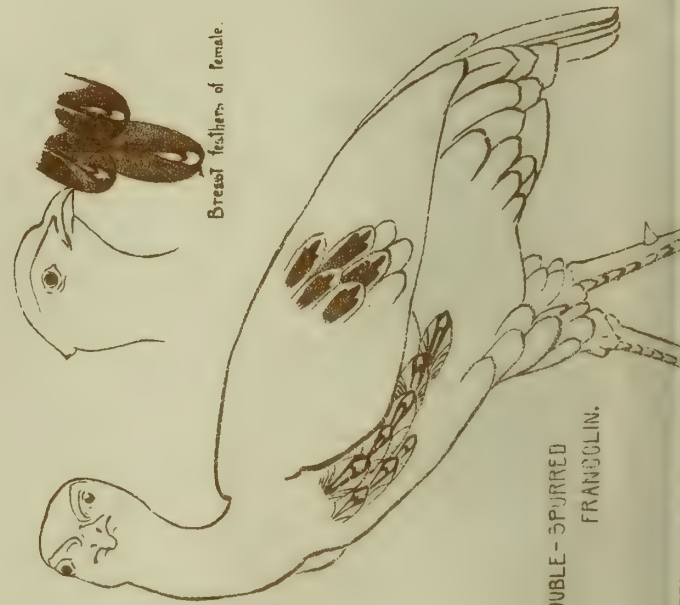

DOUBLE-SPURRED FRINGILLID

Breast feathers of female.



PAINTED FRANCOLIN.

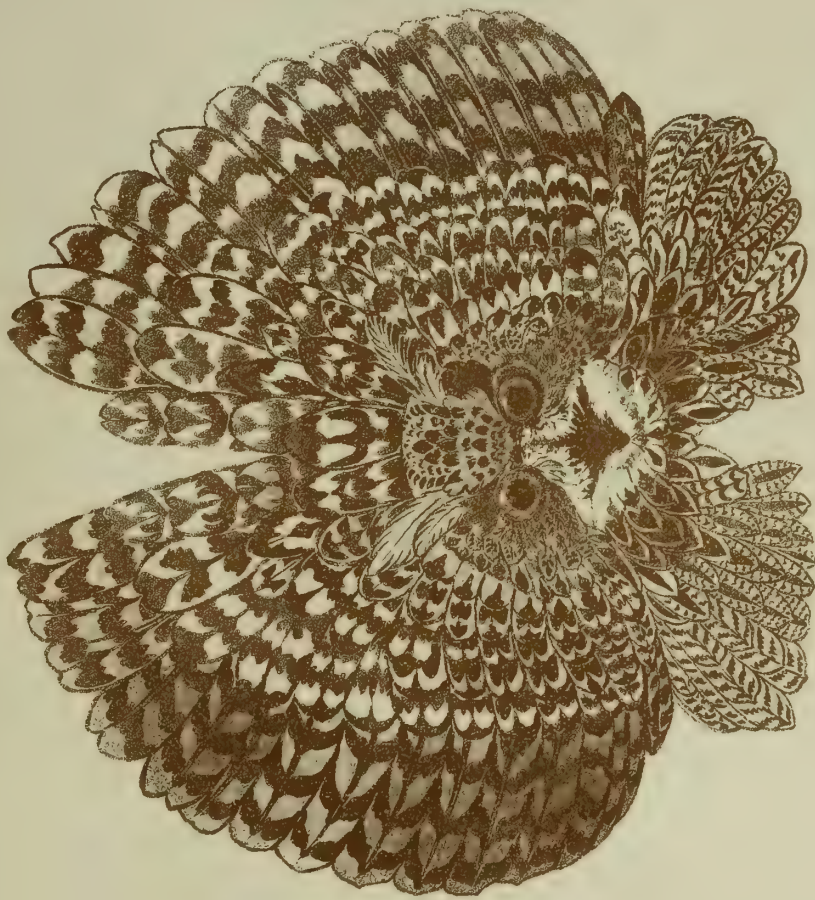

GREAT EARED OWL.



PAINTED QUAIL.



"Photo-Tint" by James Akerman of Queen Square London W.C

STUDIES OF ANIMAL LIFE TREATED FOR DESIGN NATIONAL SILVER MEDAL AWARDED MRS M EDWARDS



TO CORRESPONDENTS.

[We do not hold ourselves responsible for the opinions of our correspondents. All communications should be drawn up as briefly as possible, as there are many claimants upon the space allotted to correspondents.]

It is particularly requested that all drawings and all communications respecting illustrations or literary matter should be addressed to the EDITOR of the BUILDING NEWS, 332, Strand, W.C., and not to members of the staff by name. Delay is not unfrequently otherwise caused. All drawings and other communications are sent at contributors' risks, and the Editor will not undertake to pay for, or be liable for, unsought contributions.

Cheques and Post-office Orders to be made payable to THE STRAND NEWSPAPER COMPANY, LIMITED.

TERMS OF SUBSCRIPTION.

One Pound per annum (post free) to any part of the United Kingdom; for Canada, Nova Scotia, and the United States, £1 6s. 0d. (or 6dols. 30c. gold). To France or Belgium, £1 6s. 0d. (or 33fr. 30c.). To India, £1 6s. 0d. To any of the Australian Colonies or New Zealand, to the Cape, the West Indies, or Natal, £1 6s. 0d.

ADVERTISEMENT CHARGES.

The charge for Competition and Contract Advertisements, Public Companies, and all official advertisements is 1s. per line of Eight words, the first line counting as two, the minimum charge being 5s. for four lines.

The charge for Auctions, Land Sales, and Miscellaneous and Trade Advertisements (except Situation advertisements) is 6d. per line of Eight words (the first line counting as two), the minimum charge being 4s. 6d. for 40 words. Special terms for series of more than six insertions can be ascertained on application to the Publisher.

Front-page Advertisements 2s. per line, and Paragraph Advertisements 1s. per line. No Front-page or Paragraph Advertisement inserted for less than 5s.

Advertisements for the current week must reach the office not later than 3 p.m. on Thursday. Front-page Advertisements and alterations in serial advertisements must reach the office by Tuesday morning to secure insertion.

SITUATIONS.

The charge for advertisements for "Situations Vacant" or "Situations Wanted" is ONE SHILLING FOR TWENTY-FOUR WORDS, and Sixpence for every eight words after. All Situation Advertisements must be prepaid.

NOTICE.

Bound copies of Vol. LXXIII. are now ready, and should be ordered early (price Twelve Shillings each), as only a limited number are done up. A few bound volumes of Vols. XXXIX., XL., XLI., XLII., XLIII., XLIV., XLV., XLVI., XLVII., XLVIII., XLIX., L., LI., LII., LIII., LIV., LV., LVI., LVII., LVIII., LVIX., LX., LXI., LXII., LXIII., LXIV., LXV., LXVI., LXVII., LXVIII., LXIX., LXX., LXXI., LXXII. may still be had, price Twelve Shillings; all the other bound volumes are out of print. Most of the back numbers of former volumes are, however, to be had singly. Subscribers requiring any back numbers so complete volume just ended should order at once, at many of them soon run out of print.

RECEIVED.—J. and R.—G. A.—O. B. W.—A. P.—W. N. and Co.—T. F. (Swansea).

Correspondence.

COMPETITIONS.

To the Editor of the BUILDING NEWS.

SIR,—The thanks of the profession are due to Mr. H. B. Cresswell for his splendid paper on "Competitions" reported in last week's issue of your journal, and it is to be hoped that it will help to kill the apathy which is apparently gradually strangling us, and rendering us the butt of every little obscure urban council, who seem not to have the slightest idea of an architect's professional or social position.

I think the cause will not be far to seek, when, as is generally known among the profession, any person may call himself an architect, and in the provinces it is no uncommon thing to see a carpenter or joiner, or small builder, an auctioneer, or even an undertaker, putting the title of "architect" at the end of their names.

Of course, the general public are liable to be misled, and imagine that such people are really what they profess to be.

This is very humiliating to the gentleman's son who has paid a heavy premium, and who fondly imagines he has entered a respectable and honourable profession. The only remedy for this state of things is registration, which would, of course, mean that a man must have an architectural training to enable him to pass the rigid examination which should be held, and I fail to see that this would affect the influence of the Institute (as some people seem to imagine), which would hold a parallel position to some of the colleges in the medical and other professions.

Apologising for trespassing on your valuable space to such an extent,—I am, &c.,

REGISTRATION.



FOUR-LEGGED CRANE SCAFFOLDING.

SIR,—I venture to send you a small photograph of the four-legged crane scaffolding at the Royal Infirmary extension in this city, taken April 16, 1898. The Ilford plate negative is at your service. I much regret that none of your correspondents have been sufficiently interested in the subject of these structures to correct my calculations which you were so good as to print on

$\times 5 = 67w$ , and in the latter case the result would be only  $4\frac{1}{2}$  times as strong as  $3w \times 5$ , which is the calculation unconnected.

Applying this in par. (5), where the tower  $\frac{3}{8}$  hollow was only  $\frac{1}{3}$  the weight required, if of 32lb. wood, we now have a combined structure  $4\frac{1}{2} \times \frac{1}{3}$ , or once and a half the strength of equilibrium in a violent hurricane of 100 miles an hour. The four legs would require to be nearly

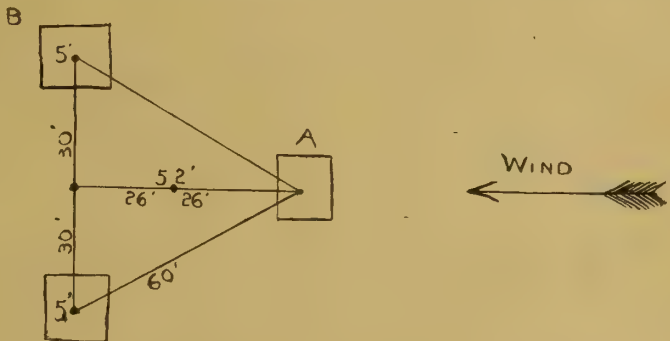

April 1, and to which I should like to add the note, which I now inclose.

The effect of the three legs or towers being so securely connected together by the horizontal lattices at top and half-way down as to form one combined structure appears to be as follows:—In the normal state the combined weight of the three towers might be supposed to be concentrated at the centre, but there will probably be a weaker and stronger position for the legs.

The weakest seems to be with one leg in front and two behind (see diagram), all being square to the wind, while the strongest position would probably be with the wind reversed.

Let  $w$  be the weight of each tower. In the normal case there would be a moment of stability of  $3w$  (26ft. by 5ft.) instead of three times  $w$  by 5ft. (as when considered unconnected), to prevent the overturn of the combined structure, or it would be about six times as strong as the separate towers. In the weakest case the moment of stability of the tower A would be increased by its greater distance from the fulcrum line BC, the moments of B and C remaining as before.

The result is naturally better in the first calculation, based on equality of situation, as the weak position of two out of the three towers overbalances the strong position of the one—i.e.,  $3w$  (26ft.  $\times$  5ft.) = 93  $w$ , while  $w$  (52  $\times$  5) + 2  $w$

3ft. square in each frame of 10ft.  $\times$  10ft. to provide this factor of safety of  $\frac{1}{2}$  under such pressure; but proportionately as before, less wind pressure would permit relatively smaller legs.—I am, &c.,

"NISI DOMINUS FRUSTRA."

Edinburgh, April 23.

The new nave and baptistery of St. Luke's Church, Rochdale, were dedicated on Saturday afternoon by Archdeacon Wilson. The late Mr. John Robinson gave the land upon which the church stands as far back as 1875, and in 1888 the chancel was built at a cost of £2,900, a temporary nave being constructed at the same time. Now the work has been completed at a further cost of £4,150.

At St. Peter's Church, Arkley, on Friday, the Bishop of St. Alban's consecrated the new chancel just added to the church. It has been erected from designs by Mr. J. C. Traylen, A.R.I.B.A., of Broadstreet, Stamford. The style is Early English, with groined oak roof and six clerestory windows. The floor is of stone, with marble in the sacrum. The chancel is 31ft. by 17ft., and the height 27ft. to the ridge of the groining, and the vestry is 20ft. by 10ft. 9in. The chancel is lighted by four three-light pendants. Additional seating accommodation for nearly 100 people is provided by means of a south transept, and the additional length added to the church. The work has been carried out by Mr. Wade, of St. Neots, Hunts.

## Intercommunication.

### QUESTIONS.

[11989].—**Workmen's Dwellings.**—Would some kind reader say the cheapest way of getting plans and specification for building workmen's dwellings, preparing for contract, &c. ?—GRANITE.

[11940].—**The New Incandescent Light.**—Can anyone give particulars of the new incandescent light, which, I am told, requires no mantles? I am sure if it is of any use, and is advertised in this and the other professional papers, architects will thankfully use it. I have tried all the incandescent lights with mantles, and while I am well satisfied with the saving in gas two of them effect, I have reluctantly ceased to use them because of the bother and expense resulting from the fragile mantles. Shall be glad of particulars of the new light.—R. T.

[11941].—**The Gold Coast.**—An advertisement has appeared several times in the columns of your paper during the last year, emanating from the Crown Agents of the Colonies, in which are sought the services of draughtsmen for the Gold Coast of Africa. As the salary offered is large in comparison with the pittance received by these professional gentlemen in this country, there are many, myself included, who would offer themselves for the post, if it were possible to get accurate information as to the duties and life. The London agents to the Crown, though most obliging, can furnish no further particulars than what appear in the advertisement, and I write on behalf of myself and others to know if one or more of your numerous readers who have perhaps spent some years on the Gold Coast in the capacity of draughtsmen to the Crown, would write a description of the nature of their duties, life, and associates, and as to who, what, and where their masters are, and whether the climate is as terrible as we in our ignorance imagine it? None to whom I have spoken seem to know anything about the subject, and I am sure that any light that could be thrown upon it through the columns of your paper would be most heartily appreciated by many clever young architects.—FIDEI TENAX.

[11942].—**Adjoining Owner.**—I am architect for some new premises which will be about 2ft. higher than the adjoining property, the owner of which objects to my flashing and fixing soakers under his slates so as to make it waterproof between the two. He has written me as to how I intend to do it. Is it usual to get permission from the adjoining owner? Also, if he refuses to have this done, can he claim any compensation for dampness afterwards? I presume flashing is not considered as an easement.—DOUBTFUL.

[11943].—**Fixing Finials.**—Will a practical correspondent inform me of the best and most secure way to fix terracotta and stone finials? Is it necessary to have a copper or metal rod up the centre, and what kind of cement should be used? Will a slate dowel be better?—ARCHITECT.

[11944].—**Cambered Arches.**—I should like to be informed how the bricks of a flat brick gauged arch are set out and the bevells found? The ordinary treatises do not treat the subject.—A. B.

[11945].—**Municipal Engineer's Qualification.**—What are the necessary qualifications for a borough surveyor, and how can a student prepare himself? Are there any books that will assist? I shall be glad to have a reply through your columns to these questions.—YOUNG SURVEYOR.

### REPLIES.

[11937].—**Powder Magazine.**—A store magazine should be solidly constructed with an arched roof; the sides and ends should be battened-up to the spring of the arch, and the roof either close-boarded or rendered in cement. Prevention of dampness is the chief point to guard against. Ventilation without being obliged to have the door open is important. Great care must be taken to protect the magazine from lightning (if in an exposed position). All metal employed for hinges, bolts, keys, &c., should be of copper or copper alloy. It depends so much on the purpose for which the magazine is required, the site, and capacity, how it should be constructed.—C. E. H., Ex-Army Reserve Officer.

### CHIPS.

The Croydon Town Council have unanimously resolved to erect new fire brigade stations at Croydon, Thornton Heath, and South Norwood, at a cost of nearly £5,000, and to provide new curricles hose-carts at four other stations.

On Saturday a special service was held in the side chapel, Brighton parish church, when a five-light stained-glass window, a memorial to the late Mr. Edward Hadly, was dedicated. The window, the artist of which is Mr. C. E. Kemp, represents the Crucifixion, the central light depicting the Saviour and the Holy Women, the lights on either side being filled with Roman soldiers, while the two further lights show the crucified thieves.

At the last meeting of the Southampton Corporation, the Housing of the Working Classes Committee brought up a scheme for the erection of artisans' dwellings on part of the cleared slum area in Simnel-street. The cost is estimated at £5,000, and accommodation will be provided for 134 people. The scheme was adopted.

There has been placed in St. Magnus Cathedral, Kirkwall, a stained-glass window to the memory of the late Provost Thomas Peace. The subject is Christ's Story of the Good Samaritan. The memorial is erected in one of the windows of the south aisle, and has been executed by Messrs. Ballantyne and Gardner, Edinburgh.

### LEGAL INTELLIGENCE.

IN RE W. AND T. CROSS, OF WARRINGTON.—At the Warrington County-court, on Friday, before his Honour Judge Pfoolkes, Messrs. Walter and Thomas Cross, builders, Warrington, applied for their discharge in bankruptcy. The petition was filed on October 7, 1896. The liabilities, according to proof, were £2,258 2s. 8d., and the assets realised £107 17s. 9d. A first and final dividend of 1½d. in the pound was all that had been paid. He reported nine serious trade offences against the bankrupts, including that they had kept no books, continued to trade after knowing they were insolvent, failed to account satisfactorily for the deficiency in the assets, guilty of rash and hazardous speculation, within three months after being unable to pay their debts had given preference to two other creditors, and each of them had made previous composition. Mr. Arthur Browne, solicitor, on behalf of the bankrupts, said these offences arose through ignorance of their position and want of education. They were hard-working bricklayers, who had begun building on their own account, first in a small way and latterly on a much larger scale, when they employed as many as 150 workmen. The judge, in reviewing the report, said it was a bad case. Ignorance and want of education was absolutely no excuse whatever. He refused the application altogether, and declined to give leave to Mr. Browne to apply further.

IN RE W. R. QUESIED.—A first meeting of the creditors of W. R. Quesied was held before Mr. A. H. Wildy, Official Receiver, on Friday. The debtor, a builder, described as of Shrewsbury-road, Stonebridge-park, states that he has been engaged in building operations since October, 1891, at Penge, Harlesden, Willesden, and Harrow. The mortgagees have foreclosed, and the debtor attributes his failure to having too many irons in the fire, and to their being too far apart. The accounts show gross liabilities amounting to about £25,000, of which £5,202 are expected to rank, and assets £470. Mr. A. C. Bourner, accountant, was appointed trustee to wind up the estate in bankruptcy.

SEWERAGE PROVISION FOR MANUFACTURING REFUSE.—PASMORE AND OTHERS V. OSWALDDESTILE URBAN DISTRICT COUNCIL.—In the House of Lords on April 28th, the Lord Chancellor, Lord Macnaghten, Lord Morris, and Lord James of Hereford gave judgment in an appeal from a decision of the Court of Appeal. The action was for a *mandamus* commanding the defendants (respondents in the present appeal) to cause to be made sewers under the Public Health Act, 1875, and to give facilities for enabling the plaintiffs to carry the liquid proceeding from his factories or manufacturing processes into the sewers under their control. The action was begun by Philip Cadell Peables (since deceased), who owned and carried on the business of paper-making at the Whiteash Paper Mill, to compel the defendants to provide sewers for the reception of the liquids from the paper mill. The claim was based on the Public Health Act, 1875, sections 15 and 21 of which impose on a local authority the duty of providing a proper sewerage system. The respondents, however, contended that such obligation was not one towards the appellants or any individual occupier, but for the benefit and purposes of the whole district. They also relied upon section 299 of the Act, which prescribes, as the remedy in such a case, complaint to the Local Government Board. The case was heard by Mr. Justice Charles on November 11, 1896, and by arrangement the question of law was argued before any evidence was gone into. The learned Judge granted the *mandamus*, but on March 13, 1897, the Court of Appeal [the Master of the Rolls (Lord Esher), Lord Justice Lopes, and Lord Justice Chitty] reversed that decision, and dismissed the action with costs. The Lord Chancellor, in moving that the appeal be dismissed, said there was nothing in the Public Health Act which would justify the issue of a *mandamus*. The whole purview of the Act made impossible the application of such a remedy. Performance of a statutory obligation could not be enforced in any other manner than that prescribed by the statute. He entirely concurred in the judgment of the Court of Appeal. The insufficiency of drainage in this case only extended to a particular manufactory. It was, therefore, within the exact words of the Rivers Pollution Prevention Act, 1876, section 7 of which provided for the grant of facilities for enabling manufacturers to get rid of refuse and enacted that no sanitary authority should be required to give such facilities where the sewers of such authority were only sufficient for the requirements of their district. The duty lay primarily on the manufacturer to get rid of his own refuse. Lord Macnaghten read a judgment to the same effect, and the other learned Lords concurred.

MANCHESTER CORPORATION V. PERKINS, GRAHAM, AND CO.: ARBITRATOR'S AWARD.—Sir Benjamin Baker, the arbitrator to whom the action of the Manchester Corporation against Messrs. Perkins, Graham, and Company, in respect to the construction of certain sewers in that city was referred, has made his award. The arbitrator finds that the

defendant company committed breaches of the contract set out in the statement of claim, and that such breaches consisted in part in the fraudulent substitution by workmen employed by the defendant company of works not in accordance with the terms of the said contract for the works which the defendant company were bound to execute, and which the said workmen were employed to execute. "It was the duty of the defendant company and the defendant James Perkins to have prevented the said fraud, and to have discovered and remedied the improper substitution of works, and that by the negligence of the defendant James Perkins, or those for whom he and the defendant company were responsible, the defendant failed to prevent or discover the same," but his failure to do this was due to negligence, and that owing to such negligence the defendant "was not aware of the said fraudulent acts, and that he was not party or privy to any fraud in the matter, and that neither he nor any other director or agent of the company having any duty or authority to make any representations to the plaintiffs on the subject made any fraudulent representations." In respect of the contract in the statement of claim, the arbitrator finds that the plaintiffs were entitled to retain the sum of £464 16s. 2d., and to receive out of court the sum of £1,900 paid into court by the defendants, and to receive from the defendant company a further sum of £1,849. In respect of contract No. 11 in the counter-claim the plaintiffs were entitled to retain the sum of £350 in satisfaction of the breaches of that contract. The arbitrator further finds that the defendants Godfrey Heathcote and Richard Jessop Dearden are liable upon their bond as sureties for the defendant company to pay to the plaintiffs the sum or sums not exceeding £1,000 in discharge or part discharge of such part of any of the said sum of £1,849 as the defendant company shall fail to pay in pursuance of the award and judgment entered thereon. Accordingly he directs that the sum of £1,900 paid into court in the action, and any interest which may have accrued thereon, be paid to the plaintiffs, and that judgment be entered for the plaintiffs against the defendant company for £1,849, and against the defendants Godfrey Heathcote and Richard Jessop Dearden jointly and severally for £1,000, but that judgment be not enforced against the last-named defendants except for such part of the sum of £1,849 as the defendant company shall have failed to pay. He orders that each of the parties shall bear his and their own costs of the action and counter-claim and all proceedings thereon, including the trial, and that the costs of the award, which are fixed at £296 15s. 6d., shall be paid, as to one moiety by the plaintiffs, and as to the other moiety by the defendant company. In conclusion the arbitrator declares that, save as aforesaid, no party to the action or counter-action is entitled to any relief against the others or other in respect of the matters referred to him.

Mr. William Saise, late surveyor to the recently-dissolved urban district council of Stapleton, near Bristol, has been elected surveyor to the urban district council of Kingswood.

The Light Railway Commissioners have informed the promoters of the Sheppey Light Railway that they will recommend the Board of Trade to issue an order empowering the construction of the proposed line from Queenborough to Leysdown. The route originally laid down by the promoters has been diverted to meet the wishes of the various public bodies in the Isle of Sheppey, who favoured a route which would bring the line more into touch with Sheerness and Minster. The cost of the line is estimated at £52,000.

After long delay, the centre span, which had been lacking to complete the London County Council's temporary iron bridge over the Thames at Vauxhall, has at length been placed in position and fixed. Its span is 165ft., and its weight about 130 tons. Although the new structure is nominally temporary, it will in reality have to do duty for probably ten or a dozen years, whilst the condemned Vauxhall and Lambeth bridges are successively undergoing demolition and reconstruction. It has been executed by the Thames Ironworks and Shipbuilding Company.

Colonel W. L. Coke held an inquiry at the Town-hall, Morley, on Friday, in respect of an application by the corporation to the Local Government Board for sanction to borrow £40,000 for purposes of street improvement, £2,600 for the erection of artisans' dwellings, and £400 for works of sewerage in Victoria-road. Plans of the various works were explained by Mr. M. H. Sykes, borough surveyor of Stockton-on-Tees, formerly of Morley, under whose supervision most of the works had been carried out.

Lieutenant-Colonel A. E. Smith, R.E., held an inquiry at Bootle, on Friday, on behalf of the Local Government Board respecting an application by the Bootle Corporation for permission to borrow £2,734 for street improvements.



## Our Office Table.

THE annual *soirée* of the Architectural Association last Friday evening reverted to the older form of a smoking concert at the Café Monico, and the return to a simpler and more convivial form of entertainment proved exceedingly popular. Among the crowded audience we noticed a large proportion of the older members of the A.A., who seized the opportunity given by a less formal gathering for a social chat with early friends. The president, Mr. Hampden W. Pratt, occupied the chair. With the exception of Mr. F. D. Clapham, nearly all those who appeared on the boards were professional entertainers, and the various selections were heartily received, and in many cases redemanded. These included a pianoforte selection by Victor Holliday, sentimental songs by Messrs. W. H. Berry, F. Pearce, M. Denis O'Sullivan, and A. S. Winckworth; recitations by Messrs. E. L. Ebsworth, Wilfred Stracey, and F. D. Clapham; ventriloquism by Mr. G. W. Kenway, and comic songs by Messrs. W. H. Berry, Bob Rae, Wilson James, Gurney Russell, and Charles Cochrane.

It is a matter for regret that the ever-flowing tide of house-building in London steadily encroaches on the outlying suburbs, and engulfs the larger mansions with their spacious grounds; but the change in the old order giving place to new is inevitable. The latest instance of the kind is the large group of freehold properties in Streatham, occupying the area between the High-road, Streatham, and the picturesque common of Tooting Bec, which is to be sold by auction by Messrs. Farebrother, Ellis, Egerton, Breach, and Co., at the Mart, Tokenhouse-yard, on Thursday in next week, the 12th inst., in one lot. There are at present situated on the properties seven family residences, with pleasure-grounds and stabling, the remainder consisting of slightly undulating park-like meadow land, and some business premises in the Streatham High-road. The estate possesses four existing frontages, nearly 3,000ft. in length, to the High-road, Tooting Bec-road, Garrad's-road, and Mount Ephraim-lane, and contains a compact area of 47 acres, "ripe for immediate development as a high-class building estate," as the auctioneers' phrase runs.

THE excavations in the island of Milo, which were recently commenced by the English School of Archaeology, under the Director, Mr. Hogarth, have been continued with much success. The first ruins brought to light were those of a very ancient Acropolis, and there were also discovered the structure of three towns, each built over the other, and two of them, as indicated by the style of the fragments and vases, belonging to the Mycenaean epoch. The third lies next to the rock. The Acropolis belongs to the island epoch, before the introduction and development of Mycenaean art. The excavations are regarded as very important in relation to the origin and extension of Mycenaean art in modern Greece. Professor Gardner, ex-Director of the School, accompanied by about twenty students from University College, London, has lately arrived in Athens, and will go to Milo to visit the excavations.

THE special sub-committee of the Birkenhead Gas, Water, and Electrical Committee, appointed last January to report upon the manufacture and supply of carburetted water gas by the corporation, now report that investigations have been made by the borough gas engineer, Mr. T. O. Paterson, M.Inst.C.E., with the result that of the 241 persons who petitioned the council complaining of badly-lighted houses and streets, and noxious smells, and alleging serious injury to health from the gas supply, 177 replied to a circular requesting a definite complaint. In 129 cases a special inspection was made, and in 38 cases the defect was remedied, 51 were satisfied without anything being done, and 30 persons remain dissatisfied. Statistics are given showing that the average illuminating power of the gas during the year was higher than the preceding four years, when water was not mixed with the coal gas. The report also states that the number of complaints fell from 3,914 in 1896 to 1,539 last year, and police complaints of street lamps were likewise reduced in a marked degree, while the utter absence now of naphthalene deposits in the services has removed a fruitful cause of complaint. As to the bad smells alleged, the committee state that every precaution is taken to prevent the emission

of bad smells at the works, and quote from a special report by Professor Sir Henry Roscoe, of London—"The products of combustion of carburetted water gas are not more injurious to health than are those of coal gas"; and a somewhat similar opinion given by Professor Lewes, F.I.C., in March last year. The gas engineer states that if the mixture of coal gas and carburetted water gas now supplied to the town is distributed and consumed with the same care and attention to pipes and fittings as has been given when coal gas only was supplied, there can be no reasonable or valid objection to the supply and use of a mixture of carburetted water gas and coal gas.

A SCHEME for supplying electric current within the whole municipal area will be submitted to Glasgow Corporation on an early date. Mr. Chamen, the newly-appointed engineer, has submitted a report on the matter to the electricity works sub-committee of the corporation, and that committee has approved generally of the suggestions made. The report states that the Waterloo-street station, with its capacity for 3,300H.P., being taxed to its utmost limit, a new site has been purchased at Port Dundas, where work has already been begun, and arrangements have been made for the purchase of another site for a generating station on the south side of the river, near Eglinton-street station. At Port Dundas there will be no difficulty in installing some 30,000H.P., and at the southern station another 15,000H.P. Waterloo-street station is at present distributing current at a pressure of 100 and 200 volts; but the Board of Trade regulations now permit current to be supplied at 250 and 500 volts, which enables the current to be carried much farther, and saves very largely in the amount of copper required in the distributing mains and feeders, the economy being about 50 per cent. The new plant already ordered for Port Dundas is designed to supply current at the increased pressure, and the plant for the southern station could be similarly designed. The capital expenditure detailed in the report is £551,000, made up as follows:—Capital expenditure at present, £150,000; capital expenditure proposed in report, £396,000; cost of removal of Waterloo-street plant, £5,000.

MR. E. M. WIMPERIS, R.I., is to be congratulated on the excellent mezzotint which Messrs. Frost and Reed, of Bristol, have just now published of this painter's breezy picture, entitled "A Wet Road." The village church, surrounded by farm homestead buildings, occupies the middle distance beyond a meadow, in front of which, and skirting the lane which is flooded by the spring rains, runs a timber foot-bridge. A waggon and horses form the central group in the foreground, and are seen emerging from an avenue of trees in full foliage, massively and richly handled, reminding one of Constable. The sunlit, rolling clouds are well in scale with the landscape, which is rich in tone and delicate in the management of its high-lights 'twixt the leaves, the effect of the whole being broadly treated, just catching the partial glow of the sunshine after the early summer's shower. The engraving, which measures about 3ft. by 2ft., including the margin, has been charmingly engraved by Mr. A. J. Skrimshire.

THE first anniversary of the Charity Bazaar fire in Paris, by which about 124 persons lost their lives, was celebrated on Wednesday by a meeting of the executive of the British Fire Prevention Committee, formed for the purpose of dealing with all matters relating to fire protection, but having special regard to the prevention, as distinct from the extinguishing, of fires. According to the provisional rules, the main objects sought by the committee are as follows:—To direct attention to the urgent need for increased protection of life and property from fire by the adoption of preventive measures. To use its influence in every direction towards minimising the possibilities and dangers of fire. To bring together those scientifically interested in the subject of fire prevention. To arrange periodical meetings for the discussion of practical questions bearing on the same. To establish a reading-room, a library, and collections for purposes of research, and for supplying recent and authentic information on the subject of fire prevention. To publish from time to time papers especially prepared for the committee, together with records, extracts, and translations. To undertake such independent investigations and tests of materials, methods,

and appliances as may be considered advisable. To facilitate the formation of centres for any of the special interests involved, to offer such technical information as these interests may require, and to issue notices, warnings, &c., for their especial benefit. To retain skilled advisers for the inspection of buildings or appliances where independent advice is desired. The list of persons who have already joined the committee not only contains a large number of names, but shows that the movement has had encouraging support from the technical professions. At their meeting on Wednesday the executive committee, of which Mr. Edwin O. Sachs is chairman, considered the definite arrangement of a series of independent tests with fire-resisting materials.

PROFESSOR HULL, late director of the Geological Survey of Ireland, read a paper before the Victoria Institute, on Monday night, descriptive of his researches as regards the river valleys and escarpments off the British Isles. Referring to the fact that the British Isles were planted on a platform raised 100 fathoms, called the 100-fathom platform, he described the platform as sloping down to the ocean-bed everywhere except off the west coast of Ireland, where it became a magnificent escarpment of 7,800ft., ending in a sloping plain going down 12,000ft. more. He held that this great escarpment was once above the sea-level previous to later stupendous physical changes. He referred to the Irish and English Channels as being submerged river-valleys, and described the North Sea, Irish Channels, and north-west coasts as having been covered in parts with land-ice, the muddy waters of the later glacial seas giving place to those of the present day.

ANOTHER cave was discovered at Oban on Saturday. On removing some earth from a rock-face at the west end of High-street, a large quantity of shells was come upon. These were recognised as of the same type as those found in the M'Arthur Cave. Messrs. Munro and M'Isaac, Oban, and Dr. Allan Macnaughton, of Taynult, took measures with the view of having the cave refuse thoroughly examined. Two bone harpoons were got early in the day. Their length is 3in., and breadth  $\frac{3}{4}$ in. The barbs are on one side, and in this they differed from the harpoons of the M'Arthur Cave, which had barbs on both sides. That the cave had been occupied for a long time was evident from the cart-loads of shells which have been taken away from the opening, and the great quantity that the workmen are still clearing away. A part of a large antler of red deer was also found. That the cave dwellers had fires was shown clearly enough, burnt wood and ashes being abundant. The vaulted roof of the cave is blackened as if by smoke. It is expected that Dr. Joseph Anderson will visit the cave and report upon it, as he did in the case of the M'Arthur Cave, which yielded such interesting relics of a far past time.

MESSRS. B. WARD AND Co., of 15, Great George-street, Westminster, London, S.W., have recently brought out a patent artificial stone step with a leaded tread, and have used them at the extension of the Architectural Museum, Donald Currie and Co.'s new offices, and other buildings. The lead is cast in the form of a grid, so that each dot is, as it were, tied together, and is  $\frac{3}{4}$ in. deep. The advantages are perfect security against slipping, great durability, neat appearance, and considerable economy.

Mr. George Keeble, of Peterborough, is opening the ground for a brickyard alongside the new railway line at Bourne, Lincolnshire. The yard is intended for the production of red bricks.

It is proposed to carry out the widening of Camberwell New-road at its junction with Camberwell Green at an estimated net cost of £31,500. The Camberwell Vestry have voted £5,000 towards the cost, and the London County Council have the matter under consideration.

The Streets Committee of the Edinburgh Town Council have resolved to recommend approval of plans of a new bridge proposed to be erected over the Water of Leith at Bonnington, at a probable cost of £5,500, and to ask a remit to meet with Leith Corporation on the subject.

A Select Committee of the House of Commons began, on Friday, the consideration of the South-wark and Vauxhall Water Bill, the objects of which are to enable the company to acquire lands, construct additional works, and take additional water from the Thames. The company propose to construct new storage for 1,076,000,000 gallons of water.

## MEETINGS FOR THE ENSUING WEEK.

SATURDAY (TO-MORROW).—Edinburgh Architectural Association. Visit to Craigiehall. By train from Caledonian Station, 2 7 p.m.

MONDAY.—Society of Arts. "Electric Traction." Cantor Lecture No. 2, by Professor C. E. Carus Wilson, of McGill University, Montreal. 8 p.m.

Bristol Society of Architects. "Plumbing," by George Tucker. 8 p.m.  
Carpenters' Hall, London-wall, E.C.  
"Strength and Strains in Wood," by Professor T. Hudson Beare, M.Inst.C.E. 7.30 p.m.

TUESDAY.—Society of Arts. "The Art of William Morris," by F. S. Ellis. 8 p.m.

WEDNESDAY.—Society of Arts. "Water-Gas and its Applications," by Professor Vivian B. Lewes. 8 p.m.

FRIDAY.—Auctioneers' Institute. Annual Dinner at the Hotel Cecil.

## CHIPS.

The memorial altar to the late Bishop Edward Bickersteth, D.D., Bishop of Japan 1886-97, leaves England this week, and will find a resting-place in St. Andrew's Church, Shiba, Tokyo, Japan, where the late Bishop so long laboured. It is composed entirely of British oak, and the elaborate sculptured panels and carvings are in high relief. The work has been executed by Messrs. Harry Hems and Sons, of Exeter.

A Jubilee church room at Soperton, Devon, designed by Messrs. Tait and Harvey, of Exeter, was opened on Wednesday in last week.

The first of Mr. J. Romilly Allen's Yates Lectures in Archaeology, the subject of which is "Celtic Art and its Developments," was delivered at University College, Gower-street, W., on Wednesday.

A font and a memorial window were dedicated in the Parish Church of St. Etheldreda, Fulham, on Saturday, by the Rev. Professor Collins, of King's College.

The Bishop of Coventry, on Saturday afternoon, preached at the dedication of the new Church of St. Edward, which has been provided by the purchase and adaptation of an old Presbyterian Chapel in New John Street West, near Summer-lane, Birmingham. About £1,200 has been expended in the purchase and alterations.

The foundation-stones of a Church Sunday-school was laid at Perranarworthal, West Cornwall, on Thursday in last week. Mr. W. Smith, of Truro, is the architect of the new building, and the contractors are Messrs. J. Row and J. Barnicott.

The Streets Committee of the Court of Common Council for the City have recommended in an amended report on the area affected by the Cripple-gate fire, that Jewin-street be widened to between 40ft. and 50ft., in that way placing it on an equality with Fore-street. At present, from No. 26 to No. 30 the width is 30ft., while the remaining portion of the street is 3ft. wider. The suggestions for improving Well-street and Hamsell-street and for extending the improvement into Smithfield and London Wall have been negated.

The new railway route between Wrexham and Mold was opened on Monday. The line runs via Brymbo, Frith, Llanfynydd, and Coed Talon. It is the joint property of the Great Western and North-Western, and from Coed Talon to Mold the last-named company is the owner.

The members of the Harold Club, at Low Moor, assembled in force on Tuesday evening at the club premises, which have recently undergone some noteworthy extensions. The principal alterations have affected the assembly-room on the ground floor, which has been considerably enlarged, and is now quite twice its original size, whilst immediately above it the billiard-room has been similarly extended, all at a cost of about £350. Mr. Healey, of Bradford, was the architect.

At the Tuesday meeting of the Birmingham City Council sanction was given to a scheme for purchasing for £2,250, land at the corner of Moseley-road and Lime-grove on which to build a branch school of art, which is to cost not more than £7,750 in addition. At the same meeting the final stage was reached in the competition for Holly Moor Asylum, the report of the assessor, Mr. G. T. Hine, F.R.I.B.A., being passed after some discussion, recommending the adoption of the plan No. 4, marked "Forward," by Messrs. Martin and Chamberlain, of that city.

A Local Government Board inquiry was held at Dublin on the 28th ult. by Mr. Cotton, chief engineering inspector, into applications made by the corporation for the following loans: £1,300 for converting the site of the Green-street Prison into an open space; £1,000 for repairing Bachelor's-walk; £3,000 for concreting footpaths; £1,900 for new paving; £4,800 for repaving; a further sum of £2,700 for concreting footways; and £364 for asphaltting.

## Trade News.

## WAGES MOVEMENTS.

BANGOR.—The carpenters employed in the Bangor building trade on Saturday intimated to the masters that unless there was an immediate increase in wages their tools would be removed. The masters, in resisting the demand, submit that longer notice should have been given, so as to enable them to readjust their estimates for contracts. At a meeting on Saturday night the establishment of a branch of the plasterers' union was decided upon. The master painters have conceded the demand for a uniform rate of wages.

BLACKBURN.—On Saturday morning the stone-masons of Blackburn and district all came out on strike for an advance of one halfpenny per hour, and against the proposal of the employers to abolish a rule prohibiting the importation of stone worked in other towns. Nearly all the towns in East Lancashire, as well as Manchester, are involved in this dispute, which may lead to a considerable stoppage of building operations.

BRIGHTON.—The masons' labourers came out on strike on Monday for a halfpenny per hour advance in wages, their present remuneration being 5½d. per hour. Some of the masters have conceded the men's demands. The building trade is very brisk at present in the borough, and it is expected that the dispute will be brought to a speedy termination.

GREENOCK.—The federation lock-out notice not having been withdrawn on Saturday by the Greenock Cabinet-making Company, Limited, the employees of the firm came out on strike. The men lifted their tools on Saturday afternoon. About 50 men are affected.

LEIGH, LANCS.—The joiners and carpenters of Leigh, Tyldesley, Atherton, and surrounding districts have requested an increase in wages from 8½d. to 9d. per hour, and a reduction in working hours from 51 to 49½ per week. The men, who number 166, were, failing these concessions, to have struck work on Saturday; but the employers sent a communication requesting the men's delegates to again meet them in a few days. They have agreed to do so, and not hand in their notices until after the conference.

PORTSMOUTH.—The Portsmouth plasterers of this town have struck work for one penny per hour advance. It is believed that an amicable settlement will soon be arrived at.

ROCHESTER.—The threatened strike in the building trades in the district of Rochester, Chatham, and Gillingham which was to have commenced on Monday, has been averted, the employers having agreed to increase the pay of the bricklayers a penny per hour, that of the carpenters a halfpenny, and that of the labourers a halfpenny per hour. The demand of the plasterers for an increase has not yet been complied with, as their notices have not expired. It is now expected that the painters will apply for an increase, so that the whole of the employees in the building industry will have improved their position considerably. Work is exceedingly brisk here, apart from that provided by the Royal Naval Barracks, the Chatham town-hall, Messrs. Barnard's theatre, the New Brompton co-operative bakeries, and other large structures in course of erection. The cost of labour has now been increased 12½ per cent., and the price of building materials has advanced all round.

SOUTH SHIELDS.—A meeting of employes and employes was held at South Shields on Monday, when it was agreed to leave the question of cementing and tiling—the bone of contention between the bricklayers and plasterers—at the discretion of the employers. Work was resumed on Tuesday at the following rates of wages:—Bricklayers, 10d. per hour; plasterers, 9½d. per hour; labourers, 6½d. per hour.

STOCKPORT.—The labour market in this town is in a very restless condition. The house painters are agitating to have their wages raised to the Manchester rate. A dispute amongst the joiners was amicably settled on Saturday at a conference between masters and men, but all the bricklayers are still on strike. The question in dispute is a proposal by the masters to curtail what is known as walking time. The employers' proposals would necessitate the men working outside the town rising much earlier to reach work.

WINSFORD.—The bricklayers of this district came out on strike on Monday, as the demands made by them in the notice just expired were not granted. They claim that they are the worst paid bricklayers in Cheshire, their wages being 6½d. per hour, against 11d. in Manchester and Liverpool, and 9½d. in Northwich. An additional 1½d. per hour has been demanded, and builders have agreed to make the concession providing the Salt Union fall in; otherwise 7½d. is offered. The men have refused this, and the Salt Union are unwilling to grant the increase.

WESTON-SUPER-MARE.—A large number of carpenters ceased work on Saturday on account of a difference with their masters. Their demand for an increase of wages to the extent of ½d. per hour was acceded to, but as the masters insisted upon altering certain of the rules of the society the men decided to go out on strike. At a meeting of the men on strike, held on Tuesday evening, a resolution was passed to the effect that no alterations could be, or should be, passed in the working rules without the six months' notice required by Rule 9, to which the masters had agreed, being duly given.

The Lord Chancellor opened the new Victoria wing of the Morley Convalescent Home for Working Men at St. Margaret's Dover, on Wednesday. The institute has been doubled in size, the accommodation having been increased from 60 to 120 beds, and a dining-hall and administrative offices have also been provided. Mr. G. Stevenson was the honorary architect.

On Thursday in last week the Bishop of Southwell dedicated the completion of the north aisle of the church of St. Alban, Sneinton. The church, designed by Messrs. Bodley and Garner, was consecrated ten years ago, but, owing to lack of funds, the north and south chancel aisles were not then built. Now the north aisle is finished.

Mr. Edward D. Conolly, a prominent contractor and builder, of New York, died at his home in that city a fortnight ago. Mr. Conolly's most important work was the building of St. Patrick's Cathedral, with the rectory and the archbishop's house adjoining; but he erected also many houses and other structures in and about New York. He was one of the founders of the Mason Builders' Association of New York, and a member of the Catholic Club.

The Unopposed Bill Committee of the House of Commons passed, on Wednesday, the Bill authorising the incorporation of a new company for the purpose of constructing a tramway from Llandudno to the summit of the Great Orme's Head. The capital of the company will be £25,000, with power to raise £6,250 upon the issue of debentures. The tramway, which will be 7 furlongs 6-80 chains in length, will be constructed as a single line. The time granted for the construction of the line is three years from the passing of the Act. This Bill has already passed the House of Lords.

The Alloa Public Baths and Gymnasium, which have been erected by Mr. John Thomson Paton for the benefit of the community, were formally opened on Friday by Mr. J. B. Balfour, M.P., Q.C.

A three-light stained-glass window has been placed in All Saints' parish church, Holbeach, in memory of the late William Rippon, who, although he lost his sight at the age of 28, continued in business as a working watchmaker. The subject is Our Lord healing Blind Bartimeus, and the work has been executed by Mr. E. M. M. Smith, of Spalding.

The committee for the restoration of the fine parish church of St. Germans, Cornwall, was formally disbanded last week, the work of restoration, on which it has been engaged for the past ten years, having been completed, at a total cost, including special gifts, of over £8,000. It was agreed to expend the balance in hand of £30 in another stained-glass window.

Six large stained-glass windows have been placed in All Saints' Church, Eastbourne, as a memorial to Lady Victoria Long-Wellesley, who built the church in 1882.

A stained-glass window has been placed in the east end of East Down Church, Devon, in memory of the Rev. T. F. Arthur, who was for 28 years rector of the parish. The subject of the window is Christ, with St. John (the Patron Saint) on the left and the Virgin Mary on the right. Mr. C. E. Kemp, of London, was the artist.

Mr. Sidney Webster, builder and contractor, of Bootle, died at his residence in Birkdale near Southport on Friday, aged 51.

A new laundry and other additions are about to be made to the workhouse at York from plans by Mr. Penty of that city. Tenders amounting to £4,437 were accepted for the works by the York board of guardians last week.

The Leicester Corporation have sanctioned the purchase of certain properties at a cost of over £6,000 for their street-widening schemes, and have decided to ask the Local Government Board for compulsory powers of purchase to acquire various other properties. The scheme will cost between £100,000 and £150,000.

The Government of Victoria intend to carry out several public works, including a scheme for the irrigation of the country, for the erection of cold storage depots, and for the opening up of the inaccessible parts of the Colony, at the aggregate cost of over two million pounds, which will be raised locally at the rate of £750,000 annually.

## THE BUILDING NEWS

AND ENGINEERING JOURNAL.

VOL. LXXIV.—No. 2262.

FRIDAY, MAY 13, 1898.

## IRRESPONSIBLE BUILDING.

AN immense number of buildings of a private and semi-public character are erected without any responsible control. The contractor in many instances becomes the mere figure-head who undertakes to carry out the work by organising labour and obtaining the materials, but he does not bind himself to do much more; if he does, he manages to throw any blame that attaches to the work on the shoulders of others, and often on the architect. He alleges an omission of something in the specification or drawings, or tries to wriggle out of his duty under the pretext of an alteration or extra. Nor can the architect be regarded as culpable. His responsibility only extends to matters of design and general supervision; but he does not guarantee that all the materials used are sound or that the workmanship is quite up to the standard required. He has to find the lowest tender at which his design can be carried out, and how can we expect him at the same time to guarantee the work? No doubt it would be honest on his part to refuse to accept a very low tender; but in ordinary business in these days he is obliged to stifle his conscience, and submit to the inevitable. Very often he is called upon to carry out work that cannot be executed at the price undertaken, and he is compelled to wink at a good deal of what is done if the building is to be finished at all. This is one of the greatest hardships of the architect's position under a contract system which binds the contractor to drawings and specifications or terms of contract that he cannot fulfil. And it places the architect in the unfortunate dilemma of either having to watch very closely the work of the contractor, or else having to pass unnoticed a number of things that are contrary to the specification standard. To object to every load of bricks or timber, or to find fault with the brickwork or the joinery, necessitates often to wink at a great many little things that are almost as important. The degree of responsibility is very largely regulated by the conditions imposed—the contract amount, time of completion, and other matters. The architect's responsibility is also a question of whether he is to have full power to provide what is necessary, or to cut and trim to meet a client's pocket or a whim. In some cases the buildings are erected for a speculative purpose to pay or sell, and the architect's control or supervision becomes a mere nominal matter. In short, an architect is engaged simply to prepare a design or a set of plans, and to see to the erection of the buildings. The employer hardly expects him to do more than to supervise the buildings in a general way. He does not look for substantial construction, for he is only a leaseholder, and does not see putting more money on another man's land than he is obliged to do. If the building endures his lifetime, he is satisfied; he only wants it designed in a tasteful or fashionable manner. Hundreds of new commercial buildings, hotels, blocks of dwellings, and offices are put up in this way. They are built to let or sell, or to do business in. Can we expect any substantial construction? Irresponsibility attaches to all buildings of this sort. If the walls, roof, or floors of a building so built give way, or kill or injure anybody, the question of responsibility is in everyone's mouth. But how can the system of building we have described be expected to produce any better

results? When, as in the recent serious collapse at Westminster, the result of which we report, the contractor states he secured the land to build upon, and that the erection was "purely a venture"; that he sub-contracted for the brickwork, concrete floors, girders, and roof, by which he lost all control and only had to do with the labourers, how can responsible building be secured? To employ an architect to prepare plans and then to leave others to carry out the contract work—this is the way many of our buildings are erected. The practice of sub-contracting has, no doubt, much to do with building failures. Foundations, brickwork, fireproof floors, or iron girders are sub-let; but very often the general contractor, who is held responsible for the work, cannot insist that the parties who undertake these branches should be placed under the same agreement or contract as he himself holds—in short, that each sub-contractor should hold under the same terms and be responsible for carrying out his particular work, as if he were working direct under the contract.

In most good contracts the provision is made that the contractor shall not, without the consent of the architect in writing, sub-let any portion of the work; and a further clause ought to be inserted that no sub-contractor, whether nominated by the architect or contractor, shall be engaged who will not enter into a contract with the latter to the effect that he will carry out the work according to the contract, and indemnifying the contractor against any claims that may be made against him in consequence of any act, omission, or fault of the sub-contractor or those in his employ. But how often is this saving clause left out, and the work is sub-let to men who have no interest in the building whatever, and who only agree to carry out such-and-such work at a given sum, but without making themselves responsible for anything beyond. The irregularities of the sub-contract work at Abbey Mansions, Westminster, illustrate this independence. It is hard to say, perhaps, what kind of contract is considered "personal" in law, especially if there is no condition of the sort we have just defined, though from certain facts, as the selection of builder, this condition of a personal contract may be implied. Employers and architects are not quite so careful as they ought to be in cases of this kind. There is a legal maxim to the effect that "no one not a party to a contract can sue on it," and according to this rule, if a builder sub-lets to a bricklayer or plasterer any part of the work, the said workman or sub-contractor cannot sue the employer. The same rule may be said to apply to employers. They cannot sue for any defect on the sub-contractor's part unless it forms a condition of contract. The right to sub-let also is larger than the right to assign, and it has been held that the contractor can claim for work he sub-lets if done properly; but he is also liable for the defects of the sub-contractor. An important point has been sometimes raised as to whether, if a sub-contractor knew the terms of the original contract, they would be binding; but the fact of knowing does not prove that the sub-contractor agreed. But these are questions of legal import into which it is not necessary to go here.

## PICTURES AT THE ROYAL ACADEMY.

[THIRD NOTICE.]

THE Fourth Gallery, with the few exceptional pictures we have noticed, need no longer detain us. A good deal of the wall-space is taken up by work of a commonplace and indifferent character, in addition to portraits. H. Weigall's large and crowded picture of the interior of a Court of Quarter Sessions at Sandwich is interesting only to a few. The painter has done his best to

delineate with minuteness the incidents and features of the particular trial represented before His Honour Judge Lumley Smith. But no painter can make such a subject pictorial. John M. Swan's poetic theme, "Fortune and the Boy," is a kind of enchanted garden in which a boy is lying down near a fountain. The painter depicts the fair phantasy of the boy's imagination or dream. From the iridescent colour of the water the fair figure of Fortune rises. The work is subtle and admirable in colour. "Electricians"—boy amateurs round a bench examining a battery or making one—is clever and vigorously painted, admirable in colour. George D. Leslie's view of "Arlington Row, Gloucestershire" (369), is interesting for the greenish hue which pervades the landscape; a row of stone houses for artisans, covered with stone shingles, with a green hilly background. The effect is that of looking at a landscape through green glasses. It is rather a conventional treatment devoid of atmosphere.

There is not much in Gallery V. Colin Hunter's "Bringing Home the Bracken" is a very fine North-country scene. A boat laden with bracken is being rowed along a river in the dusk. The reflected light of the waning day is admirably and feelingly painted. F. L. Gloag's curious picture, "The Magic Mantle"—an Arthurian legend—is mystical and clever. It represents a boy who came to the court of King Arthur "with a magic mantle which no wife could wear who was not true to her lord." T. C. Gotch has no one symbolic picture of the interest excited in his last few works. The large picture in No. VII. Gallery, called "The Awakening" (511), is scarcely as clever as the "Heir of all the Ages." It represents a vision of three angels appearing to a waking girl, who is sitting at the side of her bed. The interior appears most like the interior of a convent dormitory. Over the bed hangs a crucifix, and we just see the corbels of the roof. The colour is decorative, and the painting exquisite in finish and reverential in character. The large portrait group "The Children of L. Breitmeyer" (375) is flat in painting, and is in a subdued colour. The children are playing with toy-soldiers on a small fancy inlaid table. H. W. B. Davis's sunny landscape "Under the Greenwood Tree" (387), a slope of rich meadow land chequered in sunlight under wide-spreading trees, through which the sun casts flickering gleams of light and shadows, while a number of deer are disporting in the shade, is, without doubt, his best work. There is much in this gallery that is commonplace. Some of these are "skied," but it would have been better if they had not been hung, and had given place to others. Next after H. W. B. Davis's "Under the Greenwood Tree," is Joseph Farquharson's "As the Shades of Evening Close"; there is a true poetical feeling in the landscape. The painter represents dusk, and his colouring and reflected light on the darkening landscape and carthorses are most tenderly painted, full of fine tone. It is one of the finest landscapes exhibited. On the opposite side of the room we see a very different handling. It is by Adrian Stokes, and is called "Mountains and Hill." The hills are painted in a flat, broad manner; but the result is an effect of light and openness that redeems its bareness.

One of the most delightful seapieces is Edmund G. Fuller's "Bowl Cove, Cornwall" (402), the sunlight on the waves and foam is very fresh and sparkling in its naturalness. W. Dendy Sadler paints one of his quiet country parlour scenes, "The Young and the Old" (400), a group of country gentlemen finishing their repast. Ale and bread and cheese are on the table, and a young waitress is decanting port out of an old crusted bottle. Remains of a meat pie appear on a side tray, and one old gentleman is taking a pinch of snuff. The picture

is admirable for its quiet humour and accessories. His other and more striking picture in the next gallery is called "A Little Mortgage." In a well-furnished lawyer's office lined with books a young smirking, thrifflish dandy, cane in hand, sits opposite an elderly solicitor, who has a large parchment before him, and is casting an astonished glance through the corners of his spectacles at his client, who with perfect nonchalance, and in a light jaunty manner, is confiding his affairs. The two men are exact opposites: one is businesslike and reserved, the other a reckless, thoughtless spendthrift, whose chief object is to raise money.

Breadth and good colour are also seen in Ernest A. Waterlow's "A Moorland Road," an effective landscape, and in C. E. Johnson's landscape (432) "Through the Forest," sunlit trees and river. One of the few figure-subjects not equal to C. E. Perugini's work is "Idleness," a dark Italian girl feeding a swan with cherries. In the next gallery, T. B. Kennington's "Diana" (436) is a composition of hardly the ideal treatment we expect to find in a classical theme. The half-draped sleeping goddess and her attendant nymphs are in a wood. The colouring is exceedingly rich though harmonious, but the painter is more successful in his portraits. Near it W. H. Margetson, in "Castles of Sand," has a graceful subject: a girl seated on a sandy beach, listlessly piling up a small mound of sand. The light and colour are admirable, and the idea of girlish fancy is pleasingly rendered. Peter Graham's "Lashed by the Wild and Wasteful Ocean" (445) is a companion subject to the one we have noticed, "The Grass-Crowned Headland of a Rocky Shore" (420). In this a rocky buttress of the coast stands out, the dashing waves are relentlessly being beaten through the natural opening, broken into fine foamy spray. There is freshness and atmosphere in this vivid realisation of sea-beaten coast and the surf. The colossal picture, or rather tempera design, of Seymour Lucas, representing "William the Conqueror Granting a Charter to the Citizens of London," given by the Corporation to the Royal Exchange, is a boldly-conceived piece of decorative painting which dwarfs by its size and colour the other easel pictures. As one of a series of decorative subjects for this great City Exchange, nothing can be more effective. It is broadly treated, and the central figure of the Conqueror granting the charter to the kneeling official, the standing figure in cardinal's robe, and the retinue of the king are rich in colour, and are relieved by the massive stone Norman background of the interior. The painter has not lost sight of the importance of a decorative scheme of colour and treatment. Thomas Mostyn's "The Cloud" is Constable-like in handling and colour, and the painter has given a faithful picture of cloud effect on a landscape; but why so large a canvas? J. H. Lorimer's "Shelling 'Honesty'" (467), a large interior with portraits of a lady and her children, is wasteful, and the perspective and accessories of room ill-drawn and meagre. John R. Reid has a large picture too, in his brilliant open-air manner, vigorous in its realism. "Hiding the Deserter" has a touching side. The tearful maiden, who is standing before an open shed in which the deserter has hidden himself, tells its own tale. Beyond, we see the red-uniformed soldiers sent in pursuit, and they are being directed another way by the mother, who is doing her best to save her son. Carolus Duran's very sumptuous length portrait of "The Countess of Warwick" (484) shows the young countess in black, holding a large white rose, against heavy scarlet plush hangings; but his most important portrait group is "Madame Georges Feydeau and her Children," a picture that was at the

Champ de Mars last year, a delightful and sympathetic arrangement of the figures, and equally charming in colour. The steel-coloured satin-frocked little girl, with her white rose and loose petals on floor, is daintily painted.

Nice feeling is shown in Owen B. Morgan's "Evening." Robert W. Allan sends one of his masterful seapieces in "Winter Storm" (492), a vigorous and powerful rendering of a storm-swamped jetty and disabled vessels. Arthur H. Buckland's "Returning Home at Evening" (504), a picnic party coming through a wood in the dusk, is painted with feeling, and we must note the historical incident in Robert Hillingford's picture, "Summoned to Waterloo: Dawn of June 16, 1815," and Fred Morgan's children's group, "The Sunshine of His Heart" (497).

Two or three subject-pictures are in the next gallery. Walter Langley's "A Cousin from Town" (522), a courtyard of a fisherman's cottage, a little fellow playing the banjo to his old uncle and young cousins, is handled with the same conscientious care and sympathy we expect from this leader of the Newlyn school. The large picture of "Wreckage" (529), by C. Napier Hemy, hoisting up some broken masts on a rock by pulley tackle is powerful. The tumultuous sea breaks over the rock as the men are hauling in their "find." The large interior, "Meeting of Burns and Scott" (535), is of interest to readers. The painting of the two chief figures is careful and expressive, and there is a warm rich tone of colour in Charles M. Hardie's work. Lucy E. Kemp-Welch's great picture, "To Arms"—an incident in the camp of the Duke of York's army before the Battle of the Boses at St. Alban's—is vigorous, but less interesting than the greater canvas of the Colts in the New Forest.

J. W. North paints a truly woodland poem, "The Morning Moon" (571), in which all the subtlety of his touch and the harmony of his palette have been combined. The delicate spring-like foliage and the deep blue rushing stream have all the iridescent hues. George Clausen's large vigorous picture of a ploughed field, an old white horse and lad engaged in harrowing, is replete with that strong realism so ably depicted by this painter. The youth is about turning the horse. The sunlight on the horse and landscape is very natural and broadly painted. Robt. W. Allan's picture of a "Fisherman's Haven" is admirable in colour.

In Gallery VIII., H. H. La Thangue gives us another of his strong labour pastorals, "Harvesters at Supper"—a few labourers, men and girls, partaking of refreshment by firelight in a cornfield, is one of his best works. In a more poetic vein is William Stott's picture: "The Happy Valley"—a pleasing study of sentiment. A pretty maiden and her lover stand on the brink of a limpid stream amidst flags and foliage. H. S. Luke has a brilliant seascape, "An Idyll of the Sea"—a boy and girl in a boat on a sunlit sea (621). Solomon J. Solomons' great picture, "On the Threshold of the City, June 22, 1897," at the end of gallery, is a striking episode of the Jubilee procession. The Lord Mayor, in his scarlet and ermine robes, and Col. Burnaby the mace-bearer, the sheriffs on horseback, and a brilliant following are awaiting the Queen at Temple Bar, the decorated street forming a background. The painter has been successful in giving us good portraits, and the grouping and colour are brilliant and picturesque. Frank W. W. Topham's work, "Rescued from the Plague, 1665," tells its own tale. The child of a citizen, a saddler, is being rescued by a friend from a window. All the other children have perished from the plague, and the mother is handing her naked girl into the hands of the rescuer. The subject is painted with care. The rich, carved bay window, the doorway bearing a red cross and the words "Lord, have mercy

upon us," are eloquent details. Another brilliant picture is "Sparklets," by Robert W. Macbeth. The scene is the interior of a large skating-rink or ice carnival. Girl skaters in brilliant fancy costumes are whirling round on the ice. They hold rich drapery in their gyrations, and many gaily-dressed men and women in galleries and on the ice make up the scene. The painter has imparted the sense of rapid motion to the scene. The Hon. John Collier's large picture of "Trouble" is pathetically painted.

## MODEL SPECIFICATIONS.—XII.

TERRACOTTA—(continued).

WE now proceed to specify other details for which special care and finish in execution are necessary. Our sketches include an arched doorway with broken curved pediment and ornament; a bay window with quadrant end lights; an oriel or corner window projecting on corbel; and internal decorations. We refer to previous general clauses.

11. *Doorway*.—The doorway or entrance shown in the architect's drawing to be set out full size by the contractor, and be approved by the architect, and supplied to the manufacturer (J. C. Edwards, Ruabon, Doulton, or Hathern Station Company). The several parts, mouldings, and enrichments to be carefully modelled and jointed in accordance with the drawings. The terracotta work to be well burned and of uniform colour, free from cracks and other defects, and the arrises to be sharp and true in line, and the ornamental work clean and sharp. The side pilasters, plain (or fluted), are to be modelled in pieces 9in. (or 12in.) high and a foot or 15in. deep, to bond with brickwork, and to project 4in. (or 6in.) from the face of work; the spandrels to be of terracotta, 4½in. or 9in. deep, and to be well bonded to the brick backing, and flushed on with mortar. The moulded cornice and curved pediment end mitres to project from face of terracotta work 6in. (or 9in.), and to be well pinned into wall in cement, and jointed as shown. The elliptical arch to be carefully turned, and the arrises and mouldings kept sharp and true, and to be jointed where shown. The capitals to pilasters and keystone and the tympanum ornament to be modelled from architect's detail (or be selected from Edwards, Ruabon; Cliff and Sons, or Doulton, Lambeth, and to be approved by the architect), and to be clean and well relieved. No piece to be cut, chipped, or filed to remove the vitreous skin. The whole to be set in fine mortar, and the joints to be not more than ⅛in. and neatly weather-pointed. Clean off jambs to receive wooden frame. If necessary to describe size of pier-caps and entablature, the clause may read—  
The cornice, &c., to be 12in. high, 9in. projection, and 18in. on bed, and the pier-caps to be, say, 14in. by 14in., as in margin.

12. *Bay Window*.—The projecting quadrant-ended bay window to be executed in well-burnt red (or cane-coloured) terracotta of approved manufacture (or from Doulton's, Lambeth). Careful full-size drawings to be made from architect's design, and the mouldings and enrichments to be carefully modelled and jointed in accordance with the same. The mullions or pilasters to be formed of solid (or hollow) blocks, each 9in. high and 9in. (or 12in.) on bed, dowelled together in cement (or filled up with fine concrete as the work proceeds), and to have caps and bases, as shown in sketch, left clean and well relieved. The transoms to be in pieces, with joggled joints, as shown. The quadrants or sills and curved transoms to be formed of pieces accurately fitted and dowelled together in cement, and the curved moulded cornice, &c., over to be jointed in small pieces; the mouldings and arrises to be kept true and sharp.

The ornamental pediment and tympana to be artistically modelled and jointed to the architect's satisfaction, and to be left clean and sharp. The joints to be ⅝in. wide, and neatly pointed in coloured Portland cement. The curved portions and transoms to be supported during erection on wooden frames, and clean off and straighten the reveals of window to receive wooden sash or casement frames, and cut the brickwork to receive the heads, transoms, and sills, and pin with cement.

13.—*Oriel Window*.—The projecting or oriel window (see sketch) to be executed in well-burnt red (or buff) terracotta, made by Edwards, Ruabon, or other approved manufacturers. Full-size drawings of the corbelling and half cupola are to be made from the architect's design by the manufacturer, with the assistance of contractor and

TERRA-COTTA DETAILS

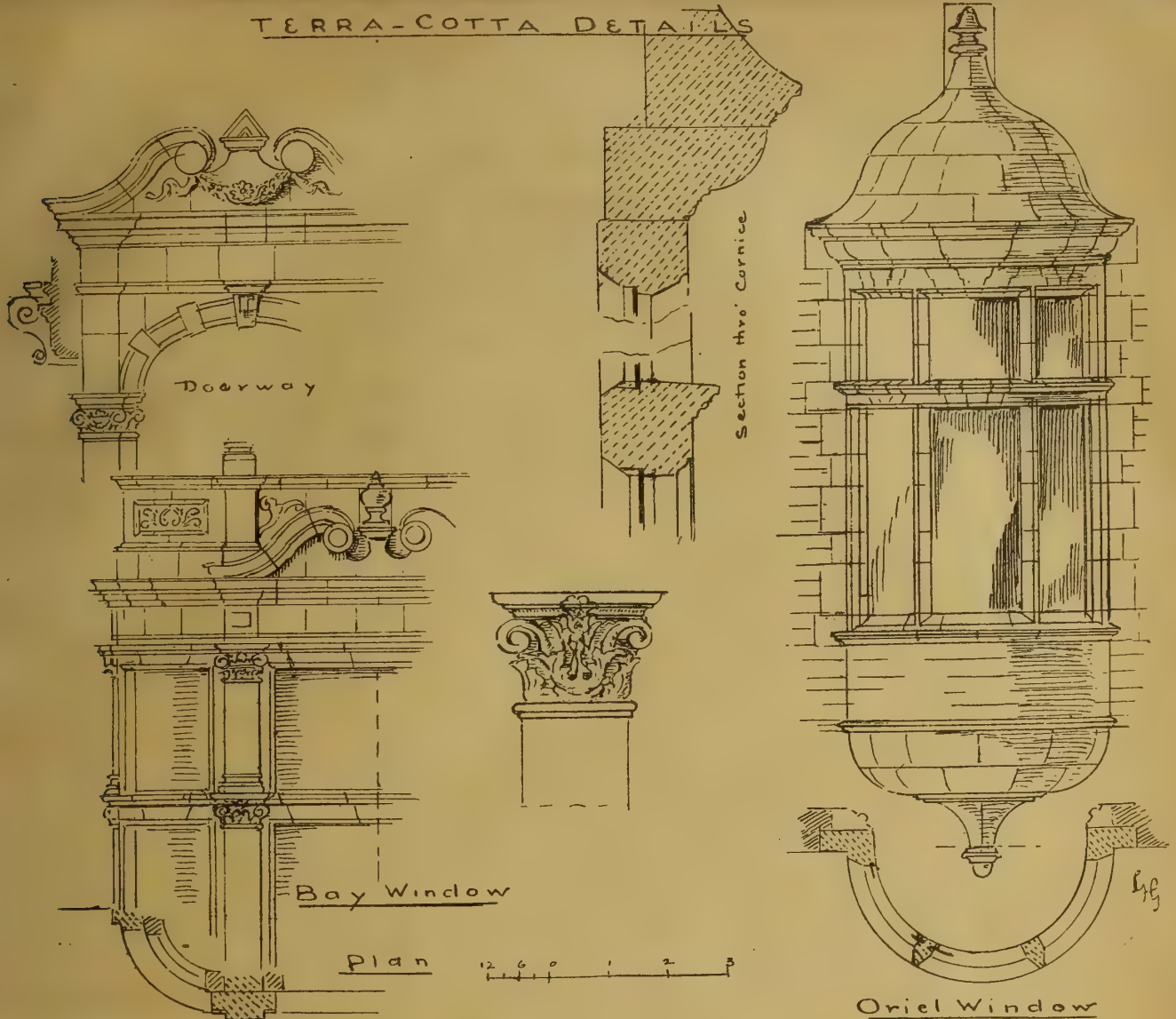

approval of the architect, the pieces of each course to be carefully moulded or modelled to accurate curve and bevells, and after "firing" are to retain their truth of form and sharpness; all mortises, grooves, joggles, and projecting parts to be prepared before the burning, so that no cutting or filing is to be required afterwards. The corbelling supporting the window is to be securely bonded or pinned into the wall, the corbel and course (or two) above it to be "tailed" into the wall at least 9in., and to be counter-weighted by a rolled iron joist to carry ends of joists. Every piece or block in each course to be dowelled in cement and the horizontal beds to form grooves and tongues (or the courses to have joggled joints) set in cement mortar with close joints not more than 1/4in. thick. Each course to break joint, and to be well tailed into wall at least 9in. The mullions to be 6in. wide by 8in. deep, and to be formed of pieces not more than 9in. in height, dowelled together. The transom and head to have radiating joggled joints, as shown in detail, and the half cupola to be executed in courses and constructed in the same manner as the corbelling, set in cement and weather-pointed as the work proceeds. (If the oriel is large and heavy, an iron or chain band should be let into the upper course of corbelling or at the springing of cupola and bolted through the wall at the end.)

14. *Cupola*.—The cupola shown in sketch (p. 591) is to be built of well-burnt terracotta free from all cracks and other defects (or supplied by Doulton and Co., Lambeth, Stiff and Sons, Lambeth, or Edwards, Ruabon). Proper angle arches to be turned at the top of square tower for the octagon base, which is to be faced with terracotta 4 1/2in. thick, well bonded and grouted in cement; the piers or columns at the angles of octagon are to be carefully modelled from the full-sized drawings prepared by architect (or contractor), and to be of pieces 12in. high and of the section shown, with projecting piece to form bond with brickwork (see plan A, p. 591), made hollow and filled in with lime concrete as the work proceeds (or the columns to be cylindrical

solid shafts, with dowels cast on to fit into corresponding mortises below in cement, bonded at every other course to the pier). The arches to be turned and jointed as shown, with keystones, and the entablature to be according to detail in two courses, 12in. (or 18in.) high, the pieces to be cramped together, and to prevent spreading or thrust a copper chain to be let into a groove in the upper course, or the upper part of peristyle to be tied by iron rods let into each corner and secured to a central ring (as shown by detail). The cupola to be executed in shaped blocks of terracotta dowelled together every third course, and well bonded into wall. The lower courses to be cast hollow, and to be 15in. (or 18in.) on bed, gradually diminishing to 6in. at the upper part. Carefully set out moulds to be made, and the blocks to be true in line and surface after burning, and no cutting, filing, or rubbing done afterwards. The whole of the work to be set in cement, and the joints are not to exceed 1/4in. in thickness, and to be neatly pointed with a bevelled joint.

15. *Niches*.—The niches (shown in drawing) to be executed in well-burnt red or buff terracotta, free from cracks and other defects, the pieces for which are to be accurately modelled from full-size details, allowing for shrinkage. The blocks to be laid in courses with radiating joints set out with proper bed-moulds and face-moulds (see sketch). Each piece to be 4 1/2in. at its thinnest part.

16. *Chimney Tops*.—Fix Doulton's or Edwards, Ruabon, Stiff and Sons', Cliff and Sons', or Hather Station Brick Co.'s red (or buff) chimney tops (Nos. 21 or 26), or Barham's patent smoke-preventing chimney-pots, price 8s. 6d. each.

17. *Chimney Shafts*.—The chimney stacks (here describe if square, octagonal, or circular), to be carefully modelled according to design and to be executed of well-burnt red (or buff) terracotta, free from cracks and other defects (or specify any particular number or design from Doulton's or Edwards's catalogue), and to be true in shape and line after burning. The flues to be 9in. (or 12in.) diameter. The shafts to have panels or pilasters

externally, and to be in pieces not more than 12in. or 18in. high, grooved and tongued or dowelled at the joints, and set in cement mortar, and neatly pointed. Or—

The chimney-stacks to have courses or bands of buff terracotta 9in. high every four courses of brickwork, with moulded caps, as shown in design, of hard burned terracotta (or the chimneys to have red or buff terracotta tops. No. 433 or 455A of Edwards, Ruabon). The tops to be well burned, true in line, and be fixed in Portland cement and faunched round base. Or—

The chimney-shafts to be built of terracotta in cement mortar. The capping to have one or two moulded courses (see drawing). The upper course to project 9in. and 12in. high, and mitres at angles, and each flue to have a terracotta pot, p.c. 3s. 6d., bedded and faunched round in cement.

Our second series of sketches illustrate the decoration of a hall or vestibule, executed in terracotta or faience, and partly taken from Mr. J. C. Edwards's catalogue. We show on the left a pier or pilaster, which may be isolated and carry arches, or project from the wall. Our paper limits prevent us showing the whole height of pilaster, and we give only the dado, base, and capital, with a small order of baluster-shaped pilasters above (see sketch in centre). The main pilasters are supposed to have some kind of relief ornament or arabesque, the upper ones are fluted. The plan shows the mode of encasing the brick piers with the terracotta. The main frieze and cornice is sketched on the right-hand corner, and a balustrade of a staircase or balcony shows the mode of fixing the pieces by dowels, a plan that may be adopted in jointing, columns, mullions, and other features. In work of a decorative character great attention should be

TERRA-COTTA DECORATION

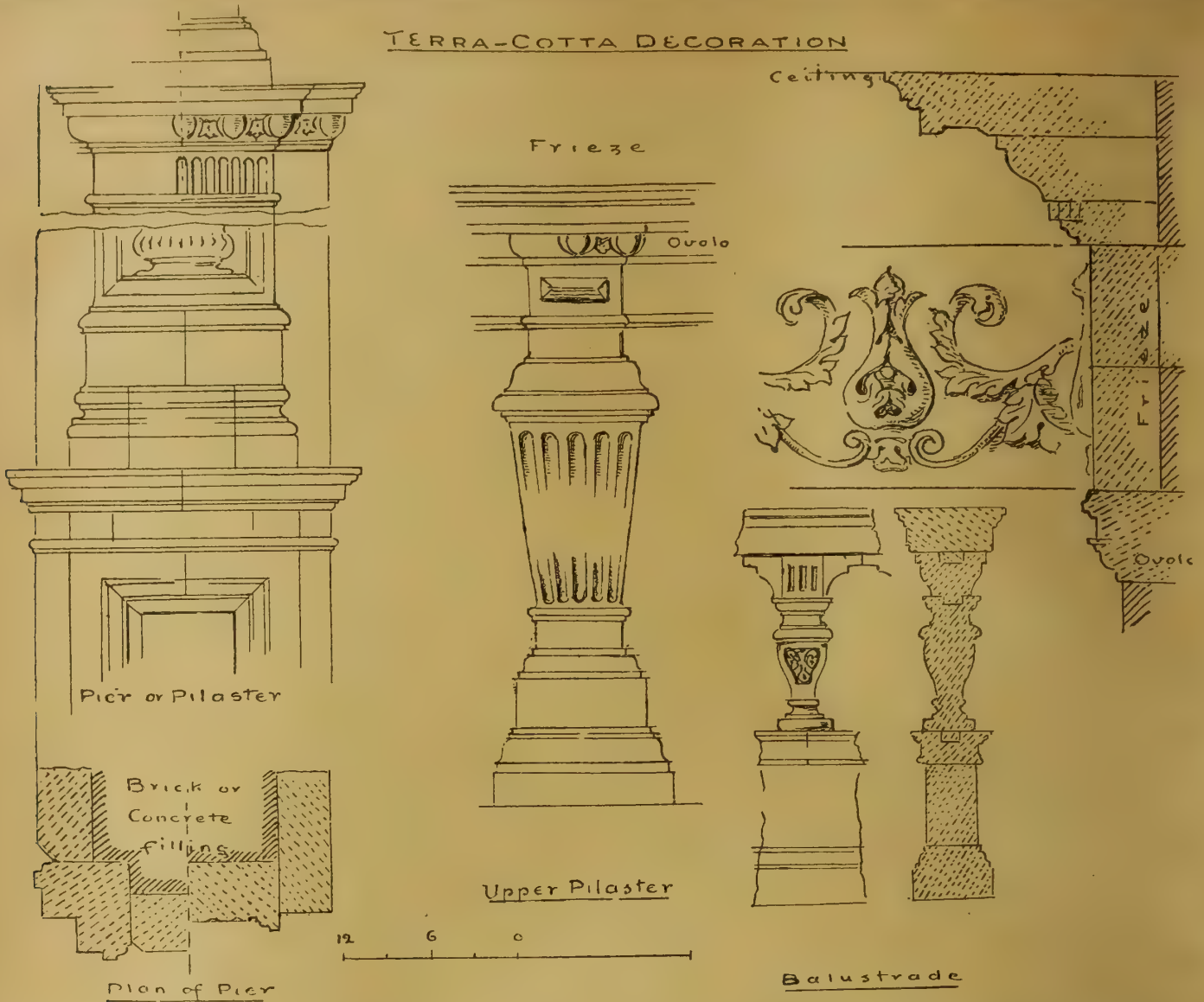

paid to the truth and accuracy of the pieces, so that after they are burned they may fairly be equal to the models. Warped or twisted blocks are disappointing, and, as a consequence, in fixing them it is difficult to obtain fine joints or truthful line or sharp arrises. Any chipping or filing destroys the vitreous skin, which is objectionable for outdoor work, and ought, if possible, to be avoided in interior. By having plenty of joints, and using small pieces, much accuracy may be attained. It is impossible to expect accurate work or fine arrises if the models are not prepared from full-size drawings made under the supervision of the architect, and allowing for shrinkage.

The clauses for internal terracotta work will follow the same lines as those already given; but, if anything, truer and more accurate workmanship and setting are required.

Faience is largely used for internal decoration, as in the lining of restaurants, vestibules, and other purposes. The clauses we have given for terracotta may be applied to faience, as the blocks are made in a similar way; but the architect should more particularly specify the tints or shades of colour, or, what is better, ought to have samples deposited with him by a good firm, and require that the work executed should be equal to the samples. Neatness and accuracy in the jointing and fine sharp arrises are most essential, though rarely found. The sketches we have given for terracotta will illustrate this sort of work, and the jointing is similar.

Glazed or enamelled brick is used for a

variety of ornamental face-work, such as to bath-rooms and lavatories, vestibules, fish-mongers' shops, dairies, restaurants, or dados of hospital wards, &c. Excellent glazed and enamelled bricks are made by J. C. Edwards, of Ruabon, made from selected clays, the coloured glazes being fired at a great heat, which is essential for durability. A clause suitable for this kind of work may be as follows:—

18. *Glazed Brick Wall Facing.*—Face walls of kitchen or vestibule with salt-glazed bricks, pointed in cement; or the dado to be faced with red buff, chocolate (or other coloured) glazed facing bricks of Edwards, Ruabon, with neat joints  $\frac{1}{8}$  in. thick, and all headers to be unbroken, with brick moulding 3 in. or 6 in. deep at top, and skirting as per sketch. The brickwork to be pointed with a flush joint in tinted mortar or Parian cement, and to be approved. The frieze to be of selected pattern 6 in. (or 9 in.) deep, or line the walls with  $\frac{1}{2}$  in. cream or buff glazed tiles in 6 in. squares, set in cement on a backing of Portland cement and sand, with a dado border 6 in. and skirting 12 in. high, pointed in coloured Parian.

Glazed and enamelled bricks are made in every variety of tint, and are made glazed on one side or one end, or on one side and one end for a return angle; they are made also with two sides and two ends glazed or one side and two ends. The best salt glazed bricks are in stretchers and headers. For dado mouldings, corners, &c., bull-nose bricks, chamfers, coigns, and other bricks are made glazed, and can be supplied by several leading manufacturers.

The foundation-stones of a new Wesleyan Church, situate in the Poole-road, Bournemouth, costing £5,000, were laid on Friday afternoon.

ELECTRIC LIGHTING NOTES FOR ARCHITECTS.—XXIII.

By AN ASSOC. INST. ELECT. ENGS.

INCANDESCENT LIGHTING.

**I**NTRODUCTION AND ELECTRIC HEATING.—The problem of lighting houses and streets is a very important one, and we need scarcely remind students that "heat lies at the root of all systems of artificial illumination." Bearing this in mind, it is evident that the electric light, although sometimes called a cold light, is an example of the heating effect of an electric current; and when we remember that the temperature of a conductor is always raised to a greater or less extent when traversed by electricity, it is obvious that the existence of the electric light is due to the intense heat which the electric current is capable of producing. To trace the connection between the electrical energy absorbed and the thermal energy generated, we must remember that electric pressure is lost whenever a current of electricity traverses a conductor, and also that the lost volts are numerically equal to the product of the current passing, and the resistance overcome, or algebraically that  $e = CR$ . For our purpose it is very instructive to consider this loss as being due to the production of a back pressure of  $e$  volts, in consequence of the passage of  $C$  amperes through a conductor of  $R$  ohms resistance, as then it is evident that a definite amount of energy is developed. To provide for this production of energy, there must be an expenditure of energy equal to  $eC$  watts, and since  $e = CR$ , it is clear that—

$$\text{Expenditure of energy} = eC \\ = C^2R = \text{energy developed.}$$

Now, this amount of energy which is developed is in the form of thermal energy; and if  $H$

denotes the total amount of heat developed in  $t$  seconds, we have, by Joule's law—

$$H = K \cdot C^2 R t \dots\dots\dots (\alpha)$$

—where  $K$  is a dimensional constant, the value of which depends upon the units used. If  $C$  be given in amperes,  $R$  in ohms, and  $H$  in calories (a calorie being that quantity of heat required to raise 1 gramme of water through  $1^\circ$  Centigrade), then  $K$  is proved by experiment to be 0.24. Furthermore, an activity of 1 watt is 1 joule per second, so that the work done by  $C$  amperes in  $t$  seconds whilst traversing a conductor of  $R$  ohms resistance, will be  $C^2 R t$  joules, and consequently 1 joule is equivalent to 0.24 calorie. Now, electric heating possesses many advantages over other forms of heating. For example, it is evident from an inspection of the formula  $H = K \cdot C^2 R t$ , that the amount of heat developed can be both perfectly controlled and localised. By adjusting the values of  $C$  and  $R$ , for instance, the amount of heat developed per second may be varied between wide limits, and by concentrating the resistance at the parts where the heat is desired, it may be readily manifested at those parts, and at those parts only. Consequently, the ratio of the energy used to that transformed is very high. But since the most important application of electric heating is the production of artificial illumination, we are, for the present, only concerned with the determination of the amount of electrical energy expended in producing thermal energy so that sufficiently high temperatures may be obtained as to produce light. If we take into consideration the thermal capacity of the material forming the conductor heated, we may express the connection between the heat developed and the temperature to which the conductor is raised in a given time  $t$  by means of the following equation:—

$$H = m \theta \dots\dots\dots (\beta)$$

where  $\theta$  is the resulting temperature, and  $m$  is a coefficient depending upon the material used, the nature of its covering, and environment. Then, again, any substance heated imparts energy by radiation or wave-motion to the surrounding ether, and if the frequency of the wave-motion be sufficiently high, as is the case when a conductor is raised to the temperature of incandescence, they affect the eye as light, so that of the total amount of radiant energy emitted by a conductor raised to a high temperature, a definite portion consists of luminous energy. Now, by Stéphan's law, the total amount of radiations in unit time emitted by a heated body is—

$$L = \epsilon \tau^4 \dots\dots\dots (\gamma)$$

Where  $L$  = total flux of radiated energy;  
 $\epsilon$  = surface of the conductor heated;  
 $\tau$  = the total absolute emissive power;  
 $\tau$  = its absolute temperature.

It is therefore evident, by comparison of equations ( $\beta$ ) and ( $\gamma$ ), that to produce a given amount of radiations, under given conditions, the energy which must be expended diminishes rapidly as the temperature rises. And, as would be expected, the ratio of the luminous energy emitted to the total amount of radiated energy also increases with the increase of temperature, it follows that the required expenditure of energy corresponding to a given amount of luminous effect diminishes greatly as the temperature increases. For lighting purposes, therefore, all that is required is that electrical energy must be supplied to raise the conductor to such a temperature that the amount of energy radiated equals the amount of energy generated in the conductor, in which case the temperature of the conductor remains constant. In many cases this point coincides with that of incandescence, and then the luminous effect is that desired. And as the fusing point of different materials varies, the question, therefore, of the material to use as a conductor for the production of electric light is a very important one, and will be referred to later.

From equation ( $\alpha$ ) it is obvious that a body may be heated to any degree by making either  $C$  or  $R$  sufficiently great; but when we consider the economical side of the question, large currents are readily seen to be undesirable. They would necessarily require massive conductors for distributing purposes, and this would mean excessive initial cost of mains, in consequence of which the cost of electric lighting would be prohibitive. The alternative, therefore, is to make the conductors which have to be heated of high resistance, and to use smaller currents. In fact, the fundamental principle adopted in all systems of electric lighting is to *distribute and concentrate* the resistance of a circuit at those points where

light is desired, and at which the heating effect will be manifested to so great a degree that they become luminous, whilst the connecting parts of the system remain practically cool. Electric lamps are, in fact, simple transformers for converting electric energy into thermal and light energy at a number of points in a circuit. There are two types of electric lamps, (1) *incandescent or glow lamps*, and (2) *arc lamps*.

The essential part of an incandescent lamp is the conducting filament made of carbonised material, which is heated by the passage of a current of electricity, until its temperature is so high that it becomes luminous. The carbon filament is supported in a glass inclosure in which as perfect a vacuum as possible has been obtained. The object of the vacuous inclosure is twofold: (1) it prevents oxidation of the carbon filament, and (2) it diminishes the loss of heat due to convection. Means also exist for connecting the filament to an electric circuit. And when we remember that no light lends itself so readily for illumination purposes or produces such pleasing effects, and that it may be soft and yet brilliant without glare, that it is clean, cool, safe, and healthy, and that it may be placed anywhere, it is not surprising that incandescent electric lighting has developed so rapidly and is universally desired. Its growth has been phenomenal; but we can only refer in brief to the early history of the development of electric lighting, although no page of history is more interesting or instructive. Probably the earliest record of a continuous light being produced by means of electricity was the announcement made by Davy, about the year 1800, that he had been able to produce an electric arc between two carbon points interposed in an electric circuit. During a demonstration given by Davy in 1810 at the Royal Institution, a battery of 2,000 elements was used to produce the arc.

As regards incandescent lighting, the first record of anything like a modern glow lamp was the application for a patent granted to J. W. Starr, of Cincinnati, in 1845, in which mention was made of a carbon burner heated to incandescence in a vacuum. It was not, however, until Professor Crookes had improved the method of producing perfect vacua that much real progress was made, and the lamp of to-day embodies ideas from each of the following workers:—Lane Fox, Swan, Edison, Maxim, Sawyer, and Mann, who individually did much to produce a satisfactory and commercial lamp during the period 1878-80.

*Manufacture of the Incandescent Lamp.*—As might be expected, considerable difference exists as to the details of the processes employed in manufacturing glow lamps, although the main principles are identical, and we shall find it convenient to divide the manufacture of an ordinary incandescent lamp into three distinct processes—*i.e.* (1) the manufacture of the filament; (2) mounting, or the fixing and supporting the filament in a glass bulb, so as to make perfect connection with the electric-light mains; and (3) the production of a satisfactory vacuum.

Considering the most essential part of a lamp *i.e.*, the filament—first it will be obvious, from what we have already said, that the filament of an incandescent lamp should possess several essential qualities if intended to form a source of light by being rendered incandescent by means of an electric current. The qualities which are indispensable are as follows: Infusibility, or at least a very high fusion point, high electrical resistance, electrical conductivity, high emissive power, homogeneity, rigidity, durability at high temperatures, and elasticity. So far as is known at present, carbon alone may be produced so as to possess all these properties to the requisite degree. Many metals, for instance, possess sufficient resistance, and are cheap and easily produced; but their melting points are too low. Of the metals, platinum and iridium alone have been used as the filament of a lamp, and, although platinum may be raised to a brilliant white heat before its temperature of fusion is reached, there is not sufficient margin between the temperature at which it is incandescent and the temperature at which it fuses to permit of its being used on a commercial scale for lamp filaments. Then, again, the electrical resistance of all conductors, with the exception of carbon, increases with the temperature, and it is a significant fact that whilst carbon naturally possesses the requisite qualities of an incandescent lamp filament to a higher degree than any other known substance, its electrical conductivity increases as the temperature

increases, and, as a general rule, the hot resistance of a carbon filament is *half* the cold resistance.

In all cases carbon filaments are produced by the calcination of carbonaceous substances at a high temperature while out of contact with air, and the carbonaceous materials used may be divided into two classes—*i.e.* (1) *those containing carbon in a free state*, such as pure (retort) carbon ground to a powder, and formed into a paste by mixing it with a hydrocarbon liquid, tarry syrup, or a solution of sugar; sometimes a mixture of lampblack and tar is used; and (2) *those containing carbon in a state of chemical combination*, such as silk, hair, woody and vegetable fibre (bass fibre and many kinds of grass), parchmentised paper and cotton, or pure cellulose ( $C_6H_{10}O_5$ ). Probably those of the second class are more commonly used than those of the first-class. Edison, for instance, used bamboo fibre, obtained by the aid of special machinery, and as it is rich in carbon, has a straight grain, and possesses great tensile strength, it has been found to answer exceedingly well, being strong enough to withstand the pulling and twisting whilst reducing it to the desired size and proportions. Swan, after having tried parchmentised paper, used parchmentised cotton, which was prepared by immersing cotton-thread in a solution of sulphuric acid and water (of specific gravity 1.64), after which it was thoroughly washed to get rid of the acid. The more common process, however, consists in forming pure cellulose by dissolving cotton-wool (which is almost pure cellulose) in a solution of zinc chloride (of specific gravity 1.8). The resulting viscous solution is then forced through a small hole into a vessel containing a liquid in which it is insoluble, as, for instance, alcohol, which causes it to set and harden. Whilst it is in this condition and before it has thoroughly set, it is forced through dies from which it comes out in the form of a thread or filament. It is worthy of remark at this point, that inasmuch as cellulose is the chief constituent of the vegetable products—cotton and linen thread, paper, &c., the result of parchmentising cotton (Swan process) is to produce a tough, horny thread of cellulose in a gelatinous semi-transparent state, so that by either process an identical substance is formed. After the threads have been thoroughly dried, they are drawn through a series of jewel dies to reduce them to a uniform diameter throughout—*i.e.*, that required, and at the same time to polish them.

The next step, common to all methods of preparing the filament, is to carbonise or to convert them into a homogeneous solid carbon filament at a high temperature. This is a very important process; and generally the filaments receive their shape at the same time by being wound on blocks or moulds of carbon of the shape required. The blocks on which the filaments have been wound are then placed in graphite crucibles, either by placing them directly in pulverised carbon, or in cases lined with charcoal dust, or they may be wrapped in cotton rag, or they may be simply separated by pieces of cardboard; in all cases a carbonaceous powder covers the contents of the crucibles, so that all the spaces are filled, after which the lid is fastened on by means of fireclay, so as to insure air-tight joints. They are then ready for the furnace, which must be specially constructed of the best refractory bricks, so as to withstand a temperature of  $1,600^\circ$  to  $1,800^\circ$  which is required for the carbonisation process. And since so much depends upon the carbonisation, every care has to be taken to avoid sudden variations of temperature, and to subject them to a gradually increasing temperature until the highest temperature for which the furnace was constructed has been attained. When we remember that the heated carbonaceous powder covering the filaments absorbs any free oxygen present in the crucible, and also the gases which are driven off from the filaments as the temperature rises, and that it is this process, in fact, which drives off everything from the filaments which is not carbon, and leaves as a residue a very pure form of carbon, homogeneous, hard, and durable, with sufficient elasticity to withstand vibration, it will be obvious that this process of calcination demands care, especially since the chemical decomposition produces contraction of the filament, amounting to about one-third of the length and diameter. Not only must the temperature of the furnace be increased gradually, but it must also be cooled gradually after the desired temperature has been reached, and it is not until the crucibles are cool enough to be

removed from the furnace by hand that they are touched. The carbon filaments are now very fragile, and it is imperative that they are carefully handled whilst being removed from the crucibles to air-tight and dust-tight boxes, in which they are placed until subjected to the next process of flashing.

It will readily be understood that in the early days of lamp-filament making much experimental work had to be performed, and that the filaments were not so regular as we should now expect them to be. It is clear, however, that if the diameter varies at different points of the filament, there would be parts of the filament differing in resistance, with the result that the filament would be unequally heated when a current was sent through it, and not only would the filament be raised to different degrees of incandescence, but there would be the possibility and probability of the filament giving way at these weak points. To equalise and regulate the section of the filament, Maxim introduced the process of flashing, and although it is not now so necessary to flash the filaments, it is usual to subject all filaments to this process to insure homogeneity, improved electrical conductivity, and a less tendency to disintegration.

The filaments having been cut to the desired length, the process of flashing is conducted as follows:—The filament is supported by spring clips or contacts, insulated from each other in a vessel completely filled with a hydrocarbon liquid or vapour (ordinary coal-gas), connection also being made by means of the contact-pieces to a suitable source of electrical energy—i.e., dynamo or battery of accumulators. Means also exist for varying the current (a variable resistance being connected in series with the source and filament), and for making and breaking the circuit as desired. The current is first adjusted so as to raise the temperature of the filament to a dull-red heat, and if it glows unequally, it is then certain that the filament is not of uniform section. The result of heating the filament is to partially decompose the gas, and to produce a deposit of minute particles of carbon on the filament. And since the quantity of carbon deposited depends upon the temperature, it is obvious that the places most heated receive most carbon, with the result that in such cases the section of the filament is equalised throughout, as is proved by the filament being uniformly luminous throughout. Not only are the weak spots strengthened, but to cover the carbonised filament with a sheath of grey, hard, brilliant carbon of increased density makes it more refractory and of uniform conductivity. The complete process takes but a few seconds, the current being gradually increased until, with a certain maximum current passing, the filament glows uniformly, giving the required candle-power. In some cases the flashing process is conducted after one filament is mounted.

The next stage in the manufacture of the lamp is mounting the filament, and in all cases the leading-in wires—i.e., those which pass through the glass bulb, and make connection with the external circuit—are always made of platinum. Platinum is invariably used, because it possesses a high fusion point, a similar rate of expansion to that of glass (the coefficients of expansion are the same through wide limits of temperature), freedom from oxidation, and ductility to a high degree. The method of connecting the carbon to the platinum is usually one of cementation, and it is imperative that two requirements must be satisfied. (1) The attachment must be electrically and mechanically good, and (2) the resistance of the junction must not be high enough to produce undue heating.

In some cases the ends of the platinum wire are tubular, into which the carbon is inserted; in other cases the platinum is flattened out, and the carbon riveted (Maxim's lamps) to it, or cemented by means of a carbonaceous cement, which is carbonised by sending a strong current through the joints. In many instances carbon is deposited on the joint by means of the flashing process, and, as will be evident, many modifications may be introduced in perfecting the process of connecting the carbon and platinum.

The final process is that of exhausting the bulb of air and moisture. As is well known, high vacua may now be readily obtained by means of the Geissler or Sprengel pumps, and it is of the utmost importance that the bulb be thoroughly exhausted, as the life of the filament depends largely upon the degree of the exhaustion obtained. (To be continued.)

## THE ARCHITECTURAL ASSOCIATION.

THE twelfth fortnightly meeting of the Association for the present session was held on Friday evening, Mr. Hampden W. Pratt, president, in the chair.

### REFLECTED LIGHTS FOR INTERIOR LIGHTING.

A paper on this subject, illustrated by numerous diagrams and plans, was read by Mr. W. ECKSTEIN, of the firm of Messrs. Hayward Brothers and Eckstein, of Southwark. The treatment of light, or the proper distribution of daylight to any building, is, said the author, of greater importance than anything else, except, perhaps, drainage, and daylight assists largely in the sanitary conditions and cleanliness of all buildings, whether offices or warehouses. Daylight

requirement is that every portion of the office should be within 20ft. to 25ft. of a window, and that that window should not open directly to the south. It is to be hoped that the disadvantages due to the direct south light to an office will soon be appreciated, and the advantage of a court or open area, with its long axis north and south, more fully understood. Offices, on a bright day, facing to the south have to have the blinds partially closed in order to reduce the glare from the sun, the consequence being the back portion of the office has to be lighted, possibly by gas or other means. Upon valuable sites, where the amount of available daylight is very limited, it is necessary that the least possible space be appropriated as mere open areas for light. To show the difference of opinions on this matter, Mr.

### COMPARISON OF SPACE SACRIFICED FOR LIGHT.

Designs.	Basement.	Ground Floor.	First Floor.	Second Floor.
Argus .....	323ft. 1 in 28'4	570ft. 1 in 16 0	1,096ft. 1 in 8'9	1,956ft. 1 in 4'7
Grand Trunks .....	None.	4,121ft. 1 in 2'2	4,121ft. 1 in 8'2	4,121ft. 1 in 2'2
Shamrock .....	45ft. 1 in 204'3	280ft. 1 in 35'3	1,822ft. 1 in 5'0	3,097ft. 1 in 3'0
Coupon .....	None.	390ft. 1 in 23'5	2,233ft. 1 in 4'0	2,233ft. 1 in 4'0
1877 .....	None.	1,166ft. 1 in 7'5	1,860ft. 1 in 6'6	2,859ft. 1 in 3'2

It may also be useful to compare the rent-producing area shown:—

Designs.	1 in 3'9	1 in 2'32	1 in 1'68	1 in 2'14
Argus .....	1 in 3'9	1 in 2'32	1 in 1'68	1 in 2'14
Grand Trunks .....	1 in 1'6	1 in 1'26	1 in 2'23	1 in 1'70
Shamrock .....	1 in 2'24	1 in 3'0	1 in 1'94	1 in 2'60
Coupon .....	1 in 1'76	1 in 2'30	1 in 1'75	1 in 2'35
1877 .....	1 in 1'9	1 in 2'97	1 in 1'66	1 in 1'54

necessarily is brought in through the windows, and the light that enters the room falls on the floor at an angle up to about 45°, where it is nearly all absorbed, and consequently does not produce the full effect that is required for all offices. The arrangement of windows lends itself to assist or detract from the result obtained, and it will be found well to keep the head of the window as near the level of ceiling as possible; at any rate, not to be more than 12in. below it. The part of a window is practically of little effect if brought within 2ft. of the floor level. The window should be placed so as to give an equal margin of wall on either side as near as possible, and the length of an office should not exceed about twice the height of head of the windows from the floor, which in the ordinary way would be a limit of about 16ft. to 20ft. The general depth of an office should be taken about 16ft., as beyond that distance light is not good, and the extra space loses value, and there is a point where the extra depth can only uselessly increase the size of an office and not produce its proportion of rent. A

### USEFUL RULE FOR THE SIZE OF WINDOWS

is that not less than 1sq.ft. for every 85ft. of cubic space and not less than 1sq.ft. for each lineal foot between the window and opposite wall inside should be given. Of course, all such rules would be varied by circumstances, as to whether on the ground, first, or any other floor, and also from what direction the light can be obtained. Generally the height of a window may be half the depth of a room less 2ft., and the width of a window one-third the width of a room. The first point to decide is the

### BEST AXIS FOR THE OPEN AREAS

or well openings. Take the average day, and suppose that the sun rises at six, 6.E. will equal 6 a.m., and 6.W. will be 6 p.m. The usual hours of business are, say, from 9 to 5, and then the angle 509, if bisected, will divide the hours of sunlight equally, and it is this line which should rule the direction of the greater length that open areas and well-holes should have. This will be found to be 15° east of north. The open area or court should be made rectangular, not square, and lengthways, north and south. A portion of sunlight (every day that the sun is visible at all) would go into all the windows in the walls during each day, and in some seasons reach the bottom of the well-hole, and, at any rate, it would reach the maximum distance at all times. If in any town the roads have this direction of 15° east of north, and the cross roads are cut at right angles to them there will be a great advantage. The conditions for a successful building for use as offices is: (1) Ease of access; (2) good light; (3) good service; (4) pleasing environment and approaches; (5) maximum rentable area consistent with economy; (6) ease of rearrangement to suit tenants; (7) minimum cost with true economy. For good light, experience confirms the statement that courts should have their long axis north and south. As to the arrangement for good light, it is generally accepted that the

Boult, of Liverpool, compiled the accompanying table, which speaks for itself, comparing the different areas so appropriated in five different competitive drawings submitted for the new Stock Exchange, Liverpool, about 15 years since. The plot was 49ft. to Dale-street, depth 197ft., back width 36ft., and the total area 9,195ft., the only street outlet being Dale-street.

### REFLECTORS.

Notwithstanding the proper arrangement of well-holes and light openings in the lower floors, it is necessary often to assist the daylight by reflectors. These are so generally known, and their good effect so considerable, that it is only advisable to point out that where possible the reflectors should be fixed at the sill instead of half-way up the window, and be exposed directly under the sky, and the light should be thrown up to the ceiling of the apartment, and if this is polished in hard plaster it will greatly assist to distribute the light throughout the room. Where volume of light is required direct,

### LIGHT SHOULD BE ADMITTED VERTICALLY.

The light passing through a skylight is very much greater than that through any vertical window, and consequently the light received from the horizontal pavement-light is much stronger than from a vertical stall-board. It is hardly necessary to dwell on the difference of reflection and refraction, but it should not be overlooked. All rays of light move in straight lines, and when they strike upon any object they glance off its surface and are wholly or partially absorbed, or pass through the object as in a sheet of glass or a body of water. In the first place, the light is said to be reflected, and in the others refracted, because its course is partially diverted from the right line in which it left the luminous body, and its direction bent or broken back according to the difference in density between the two media. The direction in which light is reflected depends upon that from which it proceeds; it is always such that a perpendicular to the surface at the place of impact bisects the angle formed by the arrival and departure of the ray. Each half of the angle represents the angle of incidence or the angle of reflection; those angles are always equal, and always in the same plane; one being known, the other is readily ascertained. The perpendicular is termed the axis of incidence, the first ray the incident ray, the other the reflected ray. It is by the reflection of the rays impinging upon them that objects become visible, and the reflective powers of the objects are very variable. At a perpendicular incidence, water reflects only eighteen rays out of every 1,000, and glass only twenty-five, while mercury reflects 666. When the rays strike the surface obliquely, the reflection is augmented; at an incidence of 40° water reflects twenty-two rays, at 60° sixty-five rays, at 80° 333 rays; while at an incidence of 89°, where the light almost grazes the surface, it reflects 721 rays out of every 1,000. Thus, as the obliquity increases, the reflection of water approaches and finally overtakes the reflection from mercury, but at no incidence, however



great, is the reflection from water, mercury, or any other substance total. Any beam of light meeting any refracting surface obliquely, it is obvious that one part of the beam will meet it before another; it is thus hindered in its motion by it as wind is hindered, but not stopped, by the trees. In lenses and prisms the emergent beam takes an oblique path, and in the case of lenses, either convergent or divergent (according to the kind of lens), and the position of the lens relative to the object. The principle on which the

## MEASUREMENTS OF REFRACTION

are based was discovered by Willebrod Snell. According to Brewster, the index of refraction is—

For glass, two of lead to one of flint .....	1.830
Plate glass .....	from 1.514 to 1.542
Crown glass .....	from 1.525 to 1.534
Water .....	1.336

In comparing the lenses used in pavement lights, I assume the index to be 1.5; therefore the angle of refraction, on entering glass from the atmosphere, is two-thirds of the angle of incidence, and on leaving the glass it is half as large again. Referring now to the lenses and prisms that are most useful in

## PAVEMENT LIGHTS

and stall boards, shop-fronts, offices, windows, &c., the first kind of glass used in decks or floors was undoubtedly the common "ship's deck light," which is a solid mass of glass with a flange all round to support same in the adjoining floor, and with a heavy drop or triangular wedge on the under side. Whether this drop was originally intended for strength, or for increasing and distributing the light, is doubtful; there is no doubt about the strength, but all the vertical rays are reflected outward again from the sloping faces on either side. We now take practically the same block of glass (which for our purpose is cut in two) and open it outwards, and you will at once see the marvellous result, and it is this principle which has been the foundation of "Haywards' patent semi-prism pavement lights." It will be seen that the vertical, or nearly vertical, ray is thrown out through the upright, or nearly upright, front of the lens at an angle a little below the horizontal, and the rays falling on the top of the lens at various angles are thrown out in a fan shape, and the steeper the back slope, with the nearly upright face a little more inclined, projects the light lower than in the previous case. Of course, such an important result, which can be obtained from a series of prisms grouped in a frame as a pavement light and protected by a patent, has been attempted by various other devices or sections of lenses. These are lying on the table, and the average result can be got by holding them in the hand and comparing one with the other. The result is generally bad, and that the makers of such lenses should have given a certain amount of encouragement by architects using them shows to a certain extent the comparative neglect in deciding such an important matter as to which is the best kind of pavement light for producing the best illuminating effect in any building. It will be seen, too, that some thought is required in assembling the lenses in a properly-constructed frame, so as to produce a satisfactory result. One section shows an attempted improvement on previous ones, but, unfortunately, there is a great difficulty in making such irregular shaped lenses perfect, when one part is so bulky and the other so thin, on account of the inequality of the glass and tension in the lens, therefore this lens in practice is a failure. This section also limits the size that can be safely made. Now coming to the vertical lights used in stall-boards, or applicable to shop-fronts, windows, &c.; the lenses used are "Haywards' reflecting lenses," which are made at different angles to suit different circumstances. Such lenses are usually employed under the shop or office front. The combined arrangement of pavement lights and stall-boards will be clearly understood from the diagrams shown. It should be noted that if any girder be introduced a very considerable portion of the light would be lost, and a heavy shadow would be cast along the ceiling. Pavement light should be supported by bearers transversely, and as little obstruction or thickness of metal be introduced at the junction of the vertical stall-board with the horizontal pavement light, and this is easily arranged by turning up the back edge of flange, which is generally called a "water bar." Fifteen years ago Messrs. Hayward Bros. fixed in two fronts of ground-floor premises,

used as offices, &c., Haywards' reflecting stall-board lights. The result is very effective, and the light often too strong; in fact, it is necessary to place the desks so that the clerks do not face the front light. These lenses can be applied in various other positions, as in lean-to or sloping roofs, &c. The frames of the upright or stall-board lights are sometimes made with rebates to the horizontal bars only or vertical bars only, and in others with a perfectly plain sectional bar without any rebate, with a small button at the intersections to retain the glasses in their position. A combination of several devices, as already more or less explained, can be introduced to such an extent, either single or combined, as may be desired. It will be seen that the upper portion of the windows can be glazed with the reflecting stall-board lenses, to throw the light to the back portion of the ground floor in almost a horizontal direction, or to throw the light slightly upwards on to the ceiling, and thereby illuminate the back portion of the office. There is a great disadvantage in running any transverse girders or beams below the level of the ceiling across the direct line of light, as these girders or beams would throw heavy and objectionable shadows, so that the ceiling, instead of being light and bright, would be shadowed, and the major portion of the reflected light lost. Under the stall-plate, stall-board lights can be fixed vertically, as in the window above, and in the pavement light "Haywards' Semiprism Lenses" fixed horizontally, and these pavement-lights could throw the light on to a stall-board light, fixed as shown when a partition is advisable to divide off the front part of basement, and this would throw a volume of light into the basement. In another sectional drawing, the ordinary daylight reflector is introduced at window-sill on first floor, and near the middle of the depth in well-hole a series of pavement-lights and stall-board lights to throw the light all round same are introduced; the arrangement of lenses throwing reverse ways should be noted. It will be seen that one or two of these plans can be adopted with more or less advantage. Many modifications suggest themselves to architects and others, and the best arrangement can readily be worked out. It will be noted that when light is obtained from definite sources, it must be taken to act in some line of greatest volume, and it is evident that the best light falling on the pavement light will be at about one-third of the angle made by the front of the building, and the line of light from the coping of the opposite building, and from the stall-board lights at about two-thirds. Again, if the street is very narrow and a high building directly opposite, the light can be usefully assisted by other lenses. In all cases, the tops of the lenses of pavement lights and front of stall-board lenses should be plain flat surfaces and kept clean. However, ornamental effects can be given, but this is generally done with a proportionate reduction or waste of light. Also, a more ornamental appearance can be given by tile inlays between the lenses of pavement lights, or a good foothold by a non-slipping material, such as lead, cement, facing, &c. Specimens and samples of such lights are numerous and difficult to show to advantage away from the factory on account of their weight, and where also they can be seen in position.

## ELECTRIC LIGHTING AS APPLIED TO ARCHITECTURE.

Mr. TOM EKIN, A.M.Inst.C.E., followed with an interesting paper on this subject. The lecturer explained that he should restrict himself to the engineering side of the question, and that he did not propose to touch upon or refer to the subject of electric lighting outside buildings—that was, upon the generating plant or other sources from whence electric energy was brought into the building or group of buildings—but should confine his remarks to internal lighting and the manner in which the current should be conveyed to the various points of light. Dealing firstly with the distribution of lights, Mr. Ekin continued, it is obvious that the lighting of different classes of buildings requires distinctive treatment, because the lighting of a cathedral cannot be compared with that of a railway station, any more than the lighting of a ball-room or drawing-room can be compared with that of a bedroom or kitchen. Each room or space which it is intended to light should be considered and examined from at least three different points of view, namely:—

(1) The purpose for which it is to be used;

(2) The decorations, furniture, and general surroundings; and

(3) The cost of the proposed lighting.

Which of these three points is the most important is probably a matter of opinion, but it may safely be assumed that the third point, or question of cost, is not the least important; because it may be taken as granted that the skill of the architect or engineer in arranging a system of lighting is in no case more marked or apparent than in getting the maximum lighting effect at minimum cost, this minimum cost including not only the first cost of putting in the work, but the more important one of annual expenditure and renewals. When considering the question of lighting new buildings by electricity, the subject can be treated and considered with a far freer hand and, generally speaking, with far greater effect than in the case of houses at present lighted by gas or other form of illuminant, because one is so very apt to take the positions at present held or assigned to gas as those most suitable for electric lamps, quite forgetting the fact that gas is so non-adaptable and lends itself with such ill grace to artistic effect that there are only certain positions in any room in which it can safely be placed. Now I shall assume as an axiom that the

## MOST PERFECT FORM OF LIGHTING

is that evolved from a hidden system of lamps; in other words, where no portion of the lamps themselves are brought in direct contact with the retina of the eye. It is, however, only right to point out that this form of lighting, like many other nice things in this world, is, generally speaking, the most expensive, because, as a rule, it means the placing of the lamp or lamps under some form of shade, whereby a large portion of the illuminating power is lost, and therefore, and in order to get the same effect or amount of light from hidden lamps as from ordinary unshaded or only partly shaded lamps, double or even treble the amount of energy has to be used. In public halls, concert rooms, churches, &c., the points of light can, if taken from the ceiling or roof, be raised sufficiently far above the heads of the audience that, unless they wantonly gaze at the lamps, no inconvenience to the eyes need necessarily be felt; but it is different in the case of ordinary rooms, be they drawing-rooms, boudoirs, or dining-rooms; and it is these classes of rooms which, in my opinion, require the most careful thought as to the disposition and arranging of the lamps. In dealing with this matter, I am dealing solely and wholly with the incandescent electric lamp, and I do not propose to touch upon the question of arc lighting this evening, because, though this light is pre-eminently suited for streets, railway stations, and other similar places, it is not, and never will be, suitable in any way for the internal lighting of buildings. Many of you here this evening must, at some time or other, have been struck with what is generally termed the "glare" of the electric light, and may possibly have thought that this was one of the inherent faults of the system. It is nothing of the sort, and the fault lies, not in the system, but in the brain of the stupid person who put it there. No sane man or woman, with any regard to their eyes, wilfully stares at the noonday sun; but it is just as idiotic to put up a clear electric lamp and gaze at it as it is to gaze at the sun. Electricity, like most other things, to be properly appreciated must be suitably adapted to the end in view, which, as before stated, is a diffusion of soft light, without the lamp from which the light emanates being brought in direct contact with the eye. I am fully aware that the cost of complying with this requirement is in many cases too heavy to allow of its being adopted, but there is no reason why every electric lamp should not in some form or other be shaded, even if the shading is simply the putting in of an "obscured" lamp in the place of a clear one. It is evident, or at any rate should be evident, that the lighting of each particular room or space should be separately considered, and that being so, it is impossible to lay down any

## HARD-AND-FAST RULES

as to what is necessary in each particular case; and it requires a certain, or I may go even so far as to say a good deal of practical experience and judgment to know the proper amount of light required, and also the position in which the lamps should be placed. Under these circumstances, therefore, it is quite impossible for me to lay down any rules which would be of the slightest

value in enabling you to properly arrange for the lighting of any building in which you are interested. There are, as you are doubtless aware, certain "rule-of-thumb" rules, which are given in pocket-books and similar literature; but I have never found them to be of the slightest value, but, on the other hand, rather misleading. Take, for instance, a drawing-room. What use is it to anyone to know that a 16 candle-power lamp will light a certain number of square feet of floor when raised a given height above it? In my opinion, none, for the simple reason that it is quite impossible to take into calculation or make due allowance for the surrounding colouring of either walls or furniture. Leaving artistic effect out of the question for the moment, it is evident nothing is easier than to drop a number of pendants from the ceiling, and if these are kept a certain distance from the floor, you can procure the maximum amount of light with the minimum number of lamps and cost. This mode of lighting is, however, not to be recommended; indeed, it is strongly to be deprecated, and when one sees a room lighted in the above manner, it is at once apparent that a Goth, Vandal, or other barbarian, has had the arranging of the lights. I think it will be generally conceded that the most pleasant, and at the same time most artistic, method of lighting ordinary living-rooms is by means of wall-brackets, standard lamps, and table lamps, the lamp in each case being shaded so as not to come in direct contact with the eye. With regard to other rooms in a house, there is not, as a rule, much difficulty in assigning the right position for the lamps and their numbers; but at the risk of reiteration I would again impress upon you the desirability of considering the lighting of each room, or, at any rate, of each principal room, separately, and from the three points of view mentioned at the beginning of this paper.

WIRING.

Now, the next portion of my paper has to deal with the manner in which the electric current is brought from the place where it enters the building to the lamps themselves—in other words, that portion of the work generally spoken of under the comprehensive term of "wiring." As you are doubtless aware, this word "wiring" includes not only the supplying and laying of the various wires and cables, but also—at least, as a general rule—the switch and fuseboards and subsidiary switches, and occasionally the necessary "cutting away and making good," this latter expression being in many cases incorrect, as you, like myself, have probably found by experience that it could be more accurately described as "hacking and tearing away, and not making good." Many of you have doubtless had before you the tenders of some electric lighting contractors for the lighting or wiring of certain buildings, and perhaps have even gone so far as to draw up a common specification to which these various firms have tendered, and you have doubtless been surprised to find that the highest tender is sometimes half as much, and in some instances as much again as the lowest, and, furthermore, have been puzzled to know what should be done under the circumstances. Of course, if no specification has been issued, the reason of the difference in prices is easily explicable, inasmuch as the contractors having no common basis upon which to draw up their tenders, simply send in an estimate for the work and material they consider necessary, with the result that if the contractor is an honest man, taking proper pride in his work and with a reputation and good name to lose, his prices must be, and always are, considerably higher than those of an individual whose commercial instincts have unfortunately prevailed and got the better of his moral ones. It is far otherwise, however, if the contractors have tendered to a common specification, because if there are great discrepancies in the tender, it is evident either that the individual quoting the lowest figure is willing to forego all profit, or else that the one quoting the highest figure intends to make a fortune. Neither of these hypotheses are probable or ever likely to occur in practice, and it will generally be found that the real cause of the differences may be found in the loose and unscientific manner in which the specification has been drawn up. For a skilful, and perhaps unscrupulous, contractor nothing is easier than to drive a coach and four through a loosely and inaccurately drawn-up specification, whilst it is evident that even an honest contractor—being

but human—will avail himself of every opportunity in interpreting an ill-drawn clause to his own advantage. Perhaps I may be considered wanting in courtesy in suggesting that you are likely to draw up a faulty specification; but I can assure you nothing is further from my thoughts, and my only object in speaking thus plainly is to insist upon the absolute necessity of drawing up the specification in the most careful manner and with a full knowledge of the requirements necessary and incidental to the proper carrying out of the work. My experience has been that many points of vital importance to the work are—probably from want of technical knowledge—entirely omitted from many specifications, and others of no technical importance are treated with a fulness and amplification entirely unnecessary. What is the use of carefully specifying the density of current allowed per square inch of sectional area in the copper conductor, when the loss of pressure, or, to use a more technical phrase, the fall in voltage, or electro-motive force is omitted? None whatever, because in the case of a light, or group of lights, placed at some distance away from the source of supply, or point from whence the electric energy is brought into the house, the contractor might possibly be carrying out his work strictly in accordance with the specification, and yet the lamp or lamps would look like "hot hairpins," owing to the fact that the very essential point of loss of pressure had not been taken into account. Again, what is the use of specifying the most heavily insulated wire and omitting the final test when the work is completed? Instances like these could be given *ad libitum*, but for the purpose of argument this is unnecessary.

TWO WARNINGS.

There are still two points which I should like to warn you against, and these are, firstly, the low-priced contractor who looks to make his legitimate (or, as some would say, his illegitimate) profits on fittings; and, secondly, the contractor who offers to put in the work so that it will comply with the ridiculously low requirements—I refer to the test of the insulation resistances—of the fire offices. In London and other towns where there are electric supply

companies, this latter danger is to a large extent rectified and guarded against by the fact that all work has to pass the more reasonable standard of the supply company; but it still remains in the cases of country houses and houses in towns where the owner or occupier generates his own electric energy.

At the close of the reading of the two papers, a vote of thanks to Messrs. Eckstein and Ekin was unanimously adopted, on the motion of Mr. BANISTER FLETCHER, seconded by Mr. FRANCIS G. F. HOOPER, and supported by Mr. MAX CLARKE.

IRONWORK AT SOUTH KENSINGTON MUSEUM.

By G. A. T. MIDDLETON.

I.—ENGLISH: SLYPE DOOR FITTINGS FROM ST. ALBAN'S ABBEY.

IN this series of notes on the collection of ironwork at South Kensington Museum it is intended largely to let the illustrations speak



for themselves, confining the remarks to bare notices of the chief points which seem to be worth mentioning. The fittings from the slype door at St. Alban's, of which there is only a reproduction in the museum, are, for their early date, remarkably free in design and varied in



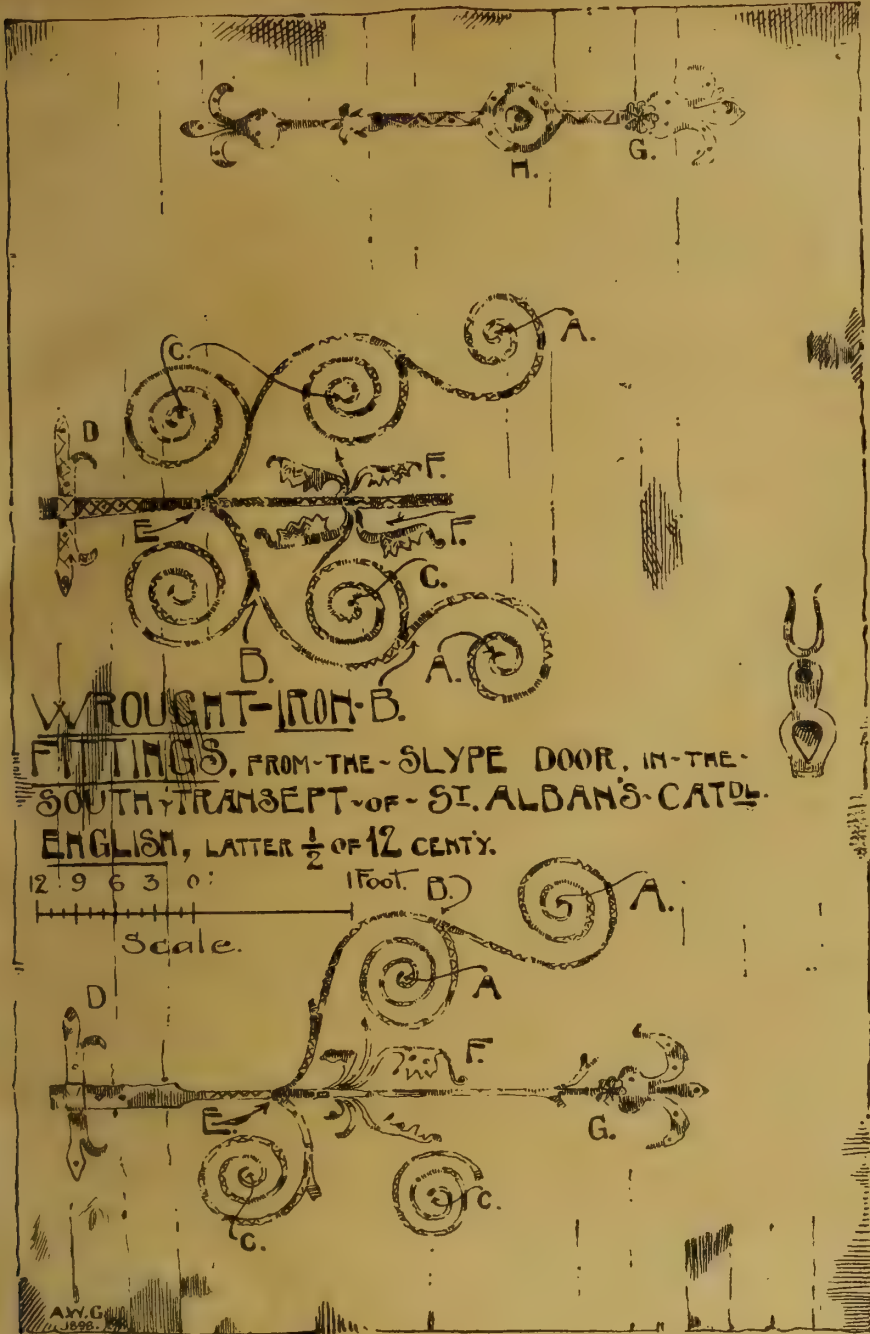

detail, the rich effect, however, being achieved by most simple means. One stamp only seems to have been employed, and that the edge of a blunt tool like a chisel, while all else is pure forging, cutting, and bending. The raised portions, as at B and E, and the twisting of terminals on edge, as at A and C, are marks of considerable courage and skill, as occurring on flat strap-hinges, and they well justify their employment. The rosette at G and the strap at D are more obvious and usual features; but the large rosette at H looks to be hammered out, and not built up of thin plates, as might be imagined.

THE RISE AND DEVELOPMENT OF THE PORTLAND CEMENT INDUSTRY.

AN address on the above subject, with special reference to the industry as carried on along the Medway, was given at the meeting of the Rochester Naturalists' Club on Wednesday in last week by Mr. W. R. Craske, the newly-elected president. He referred to the discovery by one John Aspdin, made over 70 years ago, that a combination of chalk and the blue clay found in the delta of the Medway, mixed in certain proportions and burnt to a clinker, and afterwards ground to fine powder, produced properties which, when mixed with water and incorporated with other materials of a suitable nature, produced a building material that had the advantages of great strength, durability, and cheapness, and

which would harden quickly under water as well as in the air. The late Mr. J. Bazley White and Mr. J. C. Johnston may be credited with the development of the manufacture and an improvement in the quality that gained the confidence of users in the early fifties, and works were erected on the Medway and Thames. The late Mr. Burge, whose son is still connected with some of the Rochester works, in connection with Mr. Johnston, about that time took the old oil mill at Frindsbury, and converted it into the first cement works here. Their example was quickly followed by Messrs. Lee at Halling, Milton at Faversham and Upnor, Campbell at Wouldham, Hollick at Borstal, Larke at Strood, Weekes at Whorne's-place, and one or two others. Thirty years ago the total output did not exceed 1,000 or 1,200 tons on this river in a year. He went on to describe the wet process of manufacture of Portland cement carried on during the first 40 years, and the radical changes introduced during recent years. No detail in the works had called forth so much inventive ingenuity as the process of grinding. Those of Mr. J. Collis and Mr. P. J. Neate had proved among the most successful of the mills invented. To complete the sketch he dealt with the commercial side of the trade. The cheapness of labour in Continental countries is sometimes assigned as the reason why our principal competitors can undersell us in foreign markets; but it has yet to be proved that a true Portland cement can be made cheaper in Germany and

Belgium than in England. The workmen's wage per hour is much lower there than here, but the work done is proportionately less, and the supervision is much greater. The average cost of manufacture has actually been shown to be rather lower in England. He estimated that the cement manufacturers in the neighbourhood of Rochester were now paying no less than £10,000 per week in wages, including the earnings of engineers employed upon machinery for cement works.

THE BOOK OF GLASGOW CATHEDRAL.\*

[WITH LITHOGRAPHIC ILLUSTRATIONS.]

MESSRS. MORRISON BROTHERS, of Glasgow, have just issued a monumental work, under the editorship of Mr. George Eyre-Todd; and Archbishop Eyre, with several other distinguished authorities, including Mr. John Honeyman, R.S.A., have contributed special chapters on the history and archæology of Glasgow Cathedral. The volume has been issued under the above title, enriched by 118 views and drawings, including sketches by Messrs. Herbert Railton, David Small, J. A. Duncan, and others, as well as some photographs.

It will be quite impossible, of course, in the space at our disposal to review in detail so comprehensive a work of nearly 500 pages, commencing with the "Beginnings of Glasgow," and following up with an account of the church through the dark ages, dealing with the ancient Chapter, and furnishing a list of the Archbishops and Bishops of the See after describing the fabric, and concluding with chapters on the Bishop's Castle, the episcopal seals, the prebends and manses of Glasgow, the stained-glass windows, as well as the monuments and inscriptions in the church buildings.

The foundation was established by St. Kentigern, whose birth is associated with legends fraught with conflicting evidences, the mother of the saint being an unmarried princess baptised by Servanus, who named her Tanen, of which St. Enoch, the dedicatory cognomen of one of the city churches in Glasgow, is but a corruption. Jocelyn tells us that Kentigern "established his cathedral seat in a town called Glesgu, which is interpreted *the dear family*, where he united to himself a famous and God-beloved family of servants of God, who practised abstinence, and who lived after the fashion of the primitive Church under the Apostles, without private property, in holy discipline and divine service." The editor of this admirable history furnishes an account of this ascetic churchman, whose missionary life among the pagans was marked by self-sacrifice and miracles wrought for the furtherance of his mission, which ended only with his death at an advanced old age. His tomb is shown in the lower church of the cathedral, and the necessarily obscure records of his life have been reckoned on, from all available evidences, to have been historical in the main. Those who would learn all that has been gathered by Mr. Eyre-Todd about this early prelate and his successor will find the story as here told to be exceedingly interesting and well sustained right away through the several periods down to the Reformation. For our immediate purpose to-day we must, however, leave these chapters about the bishops and the history of the chapter of the cathedral. The fabric itself, as it exists to-day, the more fittingly demands the attention of an architectural journal, and Mr. John Honeyman enables the reader to study the building with much advantage, aided by his entertaining and carefully written descriptions in the volume before us. Not a known vestige of the primitive church of Glasgow now remains, though circumstances seem to warrant the assumption that the cathedral really was erected over the tomb of the patron saint. Raised above the "haugh" in which the Molendinar flowed, the spot was sunny and retired, an excellent site for a group of Celtic cells with their usual circumvallation, but hardly suitable for a cathedral. It was not till the middle of the 12th century that any serious endeavour was made to rear the cathedral. The small piece of Transitional work in the S.W. corner of the lower church is mentioned as being possibly part of the church then erected by John Achais, whose episcopate extended from 1115 to 1147. Some attribute this

\* The Book of Glasgow Cathedral: a History and Description. Edited by GEO. EYRE-TODD. Profusely illustrated. Glasgow: Morison Bros., Renfield-street. Net price 42s.

work to Jocelin, and interesting comparisons have been made with similar details at Dryburgh, Kelso, and Jedburgh. These early remains at Glasgow give the clue to the plan of the church which occupied the ground when the choir was designed. The ruined choir at Jedburgh was probably an exact counterpart of the church at Glasgow, erected by Bishop Achaicus, and Mr. Honeyman tells us that most likely the same architect who designed the Transitional choir at Glasgow also designed the magnificent nave at Jedburgh. It was he, probably, who planned the nave for Glasgow which was never built. A plan of the church, measured by Mr. Geo. S. Hill, is given with some detail drawings capitally shown, and most admirable are the geometrical sheets contributed by Mr. Wm. J. Anderson, illustrating the architecture of the choir.

Glasgow Cathedral, shorn of its old western adjuncts, is comparatively tame and diminutive in effect; but the interior is probably more grand and more impressive than any other of the same size. It is practically a two-storied building, and in this respect differs from any other church in Britain. Many others have crypts, but the crypt, so called, of Glasgow Cathedral is not one really, but a lower church—"ecclesia inferior," as it is invariably termed in documents referring to it. A feature of great interest in the plan is the east end, where the arrangement remains without any addition or alteration exactly as it was designed by the 13th-century architect. The choir is a complete design by one man. The east end of Durham has been quoted as exhibiting a similar arrangement, but this is a mistake. It resembles Glasgow in one respect only, and that is the placing of the several altars in juxtaposition along the east wall. In the first place, the chapel of the five altars is not an integral part of the choir. The chapel at Durham is strictly, as its name implies, a separate chamber spanned by one lofty vault. It bears no resemblance whatever to two parallel aisles. The Glasgow plan is simply an adaptation of the chapels of Norman choirs, such as those at Norwich and Gloucester, to a square end. There is no other example of the kind in any of our cathedrals. The plan as a whole is compact, and the exterior is symmetrical and harmonious. One of the best points of view is from the south-east, showing the full height of the building in its dignified impressiveness. The accompanying drawing by Mr. David Small realises the actuality with taste and skill. The lower drawing on our plate is from the facile pen of Mr. Herbert Railton. We shall at an early date give some other drawings of the building, and we will then return briefly to our notice of this interesting and valuable volume, about which we have now said sufficient to inspire our readers with a desire to become personally acquainted with the book itself, which would grace the library of any architect. It is handsomely bound in buckram, and beautifully printed.

#### THE SURVEYORS' INSTITUTION.

THE following student candidates have passed the examination for the Professional Associateship:—

Arthur George Andrews, 59, Parkgate-road, Chester; Harold Bridge Baverstock, 10, High-street, Abingdon, Berks; Ernest Charles Bedwell, Homedale, Carlton Colville, near Lowestoft; Charles Windsor Berry, Bracondale House, Worpse-road, Wimbledon, S.W.; George Alfred Blyth, 24, Lonsdale-road, Barnes, S.W.; Thomas Ewen Butcher, The Rowans, Beaconsfield-road, St. Albans, Herts; Herbert Francis Carr, The Hollies, Waltham Abbey, Essex; Francis Lariot Chattell, 29A, Lincoln's Inn-fields, W.C.; Frank Sidney Chesterton, 31, Pembroke-road, Kensington, W.; Nathaniel Clark, jun., Beamish Park, Pitt Hill, R.S.O., Durham; John Constable, Arde Lodge, Southfields, Wandsworth, S.W.; Fred. Harry Arthur Danaster, Godwin, Carysfort-road, Boscombe, Hants; Charles Roland Field, Trematon, Anley-road, Anley, S.E.; Noel Macintyre Foulkes, Grove Lodge, Tring, Herts; George Ernest Howgrave Graham, Heath Rise, 12, Willow-road, Hampstead, N.W.; Joseph Edward Gripper, Whittington, Battle, Sussex; Reginald Charles Hassett, 14, Dering-street, New Bond-street, W.; John Frederick Hawkins, 6, Ravensbourne-road, Bromley, Kent; Harold Heal, Nower Hill, Finner, N.W.; Henry Cubitt Heath, Kingsbridge House, Westcott, Park, Blackheath, S.E.; Henry Hinks, 23, Tavistock-road, Croydon; Martin George Humphry, Foxton House, Royston, Cambridgeshire; Robert Ewan Jackson, Hall Gowan, Carnforth, Lancashire; Reginald Johnstone, 22, Avenue-road, Swindon, Wilts; Robert Leake, Holmleigh, Falace Gates-road, Wood Green, N.; John Lewis, Worley-road, St. Alban's, Herts; \*Donald Lloyd, 16, Hilda-road, Brixton, S.W.; Frederick Robert Lumley, College of Agriculture, Downton, Wilts; William Mortimer Marcus, 20, Strathblaine-road, New Wandsworth, S.W.; Frederick Rowland Mark, 49, Forest-road, Forest Gate, E.; Edward Ernest Meucher, 12, Marriot-road, Barnet, Herts; Sydney George Meacher, Sunny Lodge, Malvern

Link, Worcestershire; Sidney Samuel Orchard, 3, Jubilee-terrace, Leek, Stafford; Francis Arthur Pearce, 78, Blenheim-gardens, Willesden Green, N.W.; Thomas William Pearse, Stollford, Modbury, South Devon; Charles Edward Pease, Lancaster Lodge, Lauriston-road, Wimbledon, S.W.; Charles Oliver Rawstron, 29a, High-street, Rotherham; Charles Frederick Redfern, Elleray, Northfield, near Birmingham; \*Richard George Gordon Reed, Glendevon, Addiscombe-road, Croydon; Walter Francis Robbins, Crookshard, Wingham, near Dover, Kent; Sydney Searle, Hamilton House, Florence-road, Ealing, W.; Harold Sheldon, Town Hall Chambers, Middlewich, Cheshire; Harold Orlando Stallard, Heath Vicarage, Leighton Buzzard, Beds; Walter William Tremlett, College of Agriculture, Downton, Wilts; John Graham Weall, Rutland Lodge, Watford, Herts; Cyril Swaffer Weekes, Royton House, Mount Zion, Tunbridge Wells, Kent; Hugh Welsh, Dovenby, Cockermouth, Cumberland; Herbert Guy Buckell Wyatt, 10, West Pallant, Chichester, Sussex; James Dawbarn Young, Woodlands, North-hill, Highgate, N. \*Institution Prize, 1898. + Special Prize, 1898.

The following Non-Student Candidates have also passed the examination for the Professional Associateship:—

Arthur Allsebrook, Wollaton, Nottingham; Herbert George Andrews, 10, Teetot-road, King's-road, Chelsea, S.W.; Francis Houghton Angel, 50, Russell-road, Kensington, W.; Edward Guy Attlee, Combrmartin, 30, Upper Tooting High-road, S.W.; Arthur Edmund Bache, 15, Dornberg-road, Blackheath, S.E.; Geoffrey Clinton Baker, 19, St. Anne's-crescent, Lewes, Sussex; Clifton Allen Barns, 51, Brook-road, N.E.; Leigh Barrett, Heathfield, Preston-road, Southport, Lancs; Claude Wm. Boileau Barton, Castlenau, Wimbledon Hill, S.W.; Frederick Roger Benton, 26, Caversham-road, N.W.; John Charles Lebon Bettridge, 52, Hamilton-road, Wimbledon Hill, S.W.; Thomas Bibbey, Mostyn Estate Office, Llandudno, North Wales; Alfred Ernest Bradshaw, 12, Granville-terrace, Ramsgate, Kent; Arthur Allen Brown, Crown Hill, Croydon; Thomas Brown, 1, Lowther-street, Whitehaven, Cumberland; Charles Fitzpatrick Burroughes, East Witten, Middleham, R.S.O., Yorks; Albert King Burtonshaw, Market-square, Hailsham, Sussex; Reginald Robert Burton, 78, Alderney-street, S.W.; Charles Howard Campbell, Rhofes Farm, Eaton Hastings, Farringdon, Berks; Spencer Dyson Chadwick, 2, Pall Mall East, S.W.; Francis Joseph Cole, 26, Brigstocke-road, Ashley-road, Bristol; Cecil Galloway Fearn Culverhouse, 9, Whitehall-place, S.W.; Charles Tilley Darnell, Blaby, near Leicester; George Crosbie Dawson, Daisyfield, Nuneaton, Warwickshire; Frederick Burfield Dyer, 2, St. Andrew's-place, Lewes, Sussex; Arnold Robertson Ellis, 2, St. Paul's-square, Bedford; Henry Helm Foster, 27, Avenue-parade, Accrington, Lancashire; Robert Straehan Gardiner, Wenallt, Crosswood, Aberystwith, S. Wales; Joseph Stubbins Goadby, 72, Onslow-gardens, Muswell Hill-road, Highgate, N.; Oswald Judd Healing, 53, Lady Margaret-road, Highgate-road, N.W.; Cecil Stuart Hodges, Woodholme, Sherwood-rise, Nottingham; Mackintosh Meleg Holl, Sywell, Northampton; Albert William Hudson, 315, Hoe-street, Walthamstow, Essex; John Arthur Jones, 54, Grafton-road, East Acton, W.; Percy Everley Jones, 100, Gordon-road, Ealing, W.; Charles Frederick Dashwood Lang, Vigo House, Weybridge, Surrey; John Seymour Milbourne, Fairford, Gloucestershire; Arthur Morris, 12, Denbigh-place, S.W.; Harry Thomas Mullett, 6, Earl-street, Cambridge; John Oscar Nesbit, 6, Limefield-terrace, Levenshulme, Manchester; Guy Murray Nicholson, 2 and 4, Old Queen-street, Westminster, S.W.; John Nutter, 10, Lonsdale-place, Whitehaven, Cumberland; Charles Stewart Orwin, South-Eastern Agricultural College, Wye, Kent; Dudley Francis Pearce, 80, Cheapside, E.C.; Alfred Tuke Priestman, Manningham Lodge, Bradford, Yorks; Henry Charles Robertson, Boland House, Petworth-street, Battersea Park, S.W.; Percy Willben Rogers, Craigenen, Carlton-road, Putney-hill, S.W.; Frank Russell Seller, Beaufort, Bromley, Kent; Frederic Smith, Loddington, Maidstone, Kent; George Henry Smith, Brooklands, New Malden, Surrey; Percy Wontner Smith, 34, Woodberry-grove, Finsbury-park, N.; John McClure Speakman, Sunnyside, Crewe, Cheshire; Frederick William Shultise Stanton, 23, The Paddock, Chatham, Kent; Frederick Stanley Sutton, Willow Cottage, 133, Brixton Hill, S.W.; Harold Swan, 114, Trinity-road, Upper Tooting, S.W.; \*Charles John Howell Thomas, Mornington Villa, Hampstead-road, N.W.; William James Edgar Thomas, Oakridge, near Cardiff, Glamorganshire; William Edward Trent, 48, Buxton-road, Stratford, E.; Martin Hammond Ward, Carr Mill Cottage, St. Helen's, Lancashire; Herbert Andrew Cromartie Warrington, 11, Waterloo-place, S.W.; George Ford Weatherill, Edensor, Bakewell, Derbyshire; Reginald Spencer Wigram, 12A, Savile-row, W.; Peter Lloyd Armstrong Williams, 26A, Albert Bridge-road, Battersea, S.W.; John Wilson, Orgreave, Lichfield. (\* Driver Prize and Penfold Silver Medal).

IRISH CANDIDATES.—Herbert Edward Kincaid, 4, Ailesbury-road, Dublin; Holt Waring, Waringstown, Co. Down; Henry Roger Bromhead Wood-Martin, 6, Leinster-street, Dublin.

The following Professional Associates have passed the Fellowship Examination in Division IV:—

\*Frederick Stuart Angus Banks, 101, Bethune-road, Stamford Hill, N.; Geoffrey Lionel Barker, Lyndry, Rossett, North Wales; Philip Shelford Bidwell, Ely, Cambridgeshire; Charles Blackshaw, 125, Victoria-road, Kilburn, N.W.; Edwin Holmes Blake, 12, Chestnut-grove, Balham, S.W.; Edward Blount, 4, Frederick's-place, Old Jewry, E.C.; Montague Cecil Blunt, 8, Westbourne-crescent, Hyde Park, W.; George Lawrence Brighton, Claremont, 252, Barry-road, East Dulwich, S.E.; Sydney George Carnell, Rushton, Wellington, Shropshire; Harold Carmichael, 106, Croxsted-road, West Dulwich, S.E.; Alfred Stott Cartwright, 20, Nantwich-road, Crewe; George Arthur Raddon Chamberlain, Leamington House, Malvern, Wells; William Clarkson, 136, High-street, Poplar, E.; Horace Collins, Frankford House, Randolph-road, W.; Keston Nelson Crowther, Hurstbourne, 80, Victoria-road, Clapham Common, S.W.; William Denton, Raisen Hall, Wadley Bridge, Sheffield; \*Charles Gerald Eve, 2, St. Paul's-square, Bedford; Hugh

Cecil Farmer, 9, Whitehall-place, S.W.; John Harris Furmedge, Middleton Stoney, Bicester, Oxon; Henry Alexander Glover, 1, Motcomb-street, S.W.; John Nicholson Grierson, Turner's Hill, Chestnut, Herts; William Eric Leigh Jenkinson, 6, Moorgate-street, E.C.; Ernest Joel Jones, 53, Maida Vale, W.; William Thomas Lamprill, 63, The Broadway, Stratford, E.; Edwin Bennett Brierley Newton, Borough Surveyor's Office, Rochdale; Charles Osenton, 222, Brighton-road, Croydon, Surrey; Shirley Hutchins Patch, The Chestnuts, Havelock-road, Addiscombe, Surrey; Octavius Burroughes Pearse, 35, Dugdale-street, Nuneaton; Philip Peables, Estate Office, Albury, near Guildford, Surrey; Capel Hereward Price, 89, St. Paul's-road, Camden-square, N.W.; James Richardson, Jun., 15, Barn Hill, Stamford, Lincolnshire; Theodore Richard Robinson, 25, Campden Hill Gardens, Kensington, W.; Joseph Taylor Root, 23, Spencer-street, Carlisle, Cumberland; Cecil Herbert Russell, 20, Rookley-road, West Kensington Park, W.; Harry Shearburn, Munstead, Godalming, Surrey; Alfred Charles Skingle, 79, St. James-road, Brixton, S.W.; Samuel Skirshire, 153, Saltram-crescent, St. Peter's Park, Paddington, W.; Joseph Townson Sly, 62, Osborn-road, Forest Gate, E.; Arthur Carnegie Standen, 40, Courtfield Gardens, South Kensington, S.W.; Lewis Herbert Strouts, Belgrave-place, St. Mary Cray, Kent; Bruce Swanwick, Leek Woolton, Warwick; \*William Pease Theakston, 25, Ermine-street, Huntingdon; John Meadows Theobald Henley House, Spring-grove, Isleworth; William Townsend, Seacroft, near Leeds, Yorkshire; Harold Bertram Vinten, 27, High-street, Ramsgate, Kent; Stephen Gladstone Wheatley, 263, Strand, W.C.; Lawrence Richard Wilson, 20, Albert-square, Manchester; Robert Stephenson Woolf, Estate Office, Lowther, Penrith, Cumberland. (\* Penfold Gold Medal, 1898. + Bracketted equal, Crawler Prize, 1898.)

The following candidates have passed the direct Fellowship Examination in Division V:—

Albert Player Isaac Cotterell, Lonsdale Chambers, Baldwin-street, Bristol; Joseph Harry Fry, 64, Craven Park, Willesden, N.W.; William Maltby Kerruish, 21, Athol-street, Douglas, Isle of Man; Joseph Archibald Maxwell, 21, Marlborough-road, Banbury, Oxon; Arthur Fletcher Reid, 5 and 6, Clement's Inn, Strand, W.C.; Joseph Samuel Rowland, Bridge Chambers, Burton-upon-Trent, Stafford; Samuel Parr Stewart, The Lawn, Arbury, Nuneaton, Warwick; Edwin Thomas Tutti, 3, Clarendon-road, Lewisham, S.E.

Twenty-five other candidates in the different Divisions are referred back to their studies in their typical subjects.

#### THE PASSMORE EDWARDS HOMES FOR EPILEPTICS, CHALFONT ST. PETER'S.

YESTERDAY a triple ceremony took place at the Colony for Epileptics which Mr. Passmore Edwards has given to the National Society for the Employment of Epileptics at Chalfont St. Peter, Bucks. The Duchess of Marlborough opened the Victoria House—a home for twenty-four men—which has just been completed from the designs of Mr. Maurice B. Adams, F.R.I.B.A., at the cost of Mr. Passmore Edwards. The builder is Mr. George Darlington, of Amersham. The foundation-stone was laid last summer by the Honourable T. F. Bayard, the late American Ambassador, as his last public act before returning to the United States. We illustrated the building on May 7th, 1897. The second ceremony yesterday was performed by the Duke of Marlborough, who laid the foundation-stone of the home which Mr. Passmore Edwards is building for housing twenty-four boys, and the third item in the day's proceedings was performed by Mrs. Passmore Edwards, who laid the memorial-stone of the Home for Girls, also in course of building, from the plans prepared by Mr. Maurice B. Adams, at the expense of Mr. Passmore Edwards. Illustrations of these buildings appeared in the BUILDING NEWS for June 25, 1897. Messrs. Miskin and Sons are the builders of both homes. Red brick and tiles are the materials employed, with rough cast upper stages, and stone sparingly used. An Isolation Home is being proceeded with close by, and near the Passmore Edwards Home a third house for twenty-four men has just been commenced, to be called the Greene Home. These are being carried out by Mr. George Darlington, the builder, and Mr. Adams is the architect. All of the buildings are varied in design, but in style and picturesqueness are made to harmonise.

#### THE COLLAPSE OF THE ROOF OF ABBEY MANSIONS, WESTMINSTER.

AT the Westminster Coroner's Court, on Monday, Mr. John Troutbeck, who was assisted by Mr. John Slater, B.A., F.R.I.B.A., as assessor, resumed his inquiry into the circumstances attending the death of the seven men killed by the collapse of the south portion of the building known as Abbey Mansions, Victoria and Orchard-streets, on April 21. The names of the victims are:—William Clifford Morse, 21, labourer; Joseph Henry Parker, 32, foreman;

Charles Weatherley, 47, labourer; Ernest George Lillywhite, 21, labourer; Hugh John Bray, 40, engine-driver; George Bridges Hillings, 28, bricklayer; and Henry Clements, 38, labourer. Mr. G. I. L. Blenkinsopp, inspector of factories, represented the Home Office, and Mr. H. Ashmead her Majesty's Office of Works. Mr. Thomas Blashill, superintending architect of the London County Council, and Mr. Seager Berry, of the Solicitor's department of the Council, watched the case on behalf of that body. Mr. A. C. Kent, solicitor, appeared for Mr. Rickard, the principal contractor; Mr. G. I. Edwards, solicitor, for Mr. S. Murrell, the contractor for the roof; Mr. G. C. Gardiner, solicitor, for relatives of Clements; Mr. Alexander Thompson, solicitor, for the relatives of Weatherley; and Mr. Roverson for the Institution of Surveyors. Mr. Alfred A. Hudson, barrister, held a watching brief for two merchants interested. Mr. Charles James Chimney Pawley, of Prince's Mansions, Victoria-street, said he was the architect of the buildings in Orchard-street. He was instructed by Mr. Rickard about two years ago to prepare plans and specifications, which he did. He submitted the plans to the district surveyor. The freeholders at that time were the governors of the Greycoat Hospital. After the plans were submitted to the district surveyor, the south block, which included the fallen part, was entirely re-planned. New plans were prepared about twelve months ago, and at that time some of the work had been done. The alteration affected the whole of the interior of the building. The new plans were submitted to the district surveyor. The work was carried on under witness's supervision. Mr. Rickard had a free hand in construction, subject to the provisions of the London Building Act. He visited the building at least four days a week. On November 17, 1897, representatives of Her Majesty's Office of Works came upon the scene, and a day or two later they entered into an agreement to take the building on lease. When the Government took it over he placed the building under the supervision of his assistant, Mr. Simpson. The Government had nothing whatever to do with the construction. Witness visited the building on Wednesday, April 20, the day before the accident. When on the roof of the south block he noticed several carpenters fixing skylights, and that there was considerable jarring going on. He further noticed that about three-fourths of the roof had been concreted for about a fortnight, and was quite dry; and that the remaining fourth—the part which collapsed—had been concreted quite recently. He gave Mr. Simpson strict instructions not to have any of the centres on the roof struck until he himself gave orders for it to be done. He had at that time in his mind a similar accident that had occurred in the same neighbourhood owing to the centres being struck too soon. A pier ran up through the building supporting the girders of the six floors and the roof. That pier weighed 28 tons, and the weight it would have to carry would be about 47 tons. The floors were carried by girders. The plans provided for an iron stanchion which was not put in. That stanchion would have carried 30 tons, and would have reduced the weight on the pier to 37 tons. On several occasions he gave instructions to Simpson, his representative, to have the stanchion put in. Mr. Rickard, the contractor, knew that it was to be put in. The Coroner: Is that the usual way of construction—to put in a stanchion after the building is up?—It is done, if it is safe to do it. In reply to further questions the witness said that no date was fixed in the Government contract for completion; but they were endeavouring to complete by mid-summer. He visited the building about a quarter of an hour after the accident, and found it was practically gutted. He went on the roof of the north block, and asked Simpson whether he had carried out his instructions with regard to the striking of the centres. Simpson referred him to the roof contractor, who admitted that Simpson had instructed him not to remove the centring. Witness was satisfied that the removal of the centring was the initial cause of the accident. The concrete which fell from the roof weighed between 15 and 20 tons. The total weight involved in the collapse was between 150 and 200 tons. He examined the fallen concrete, and found it saturated with water. He was able to distinguish Banks's fireproof concrete, which was perfectly dry. The girders, which were of steel, were supplied to the order of Mr. Rickard by Messrs. Drew-Bear, Perks, and Co. He

could not tell what bearing the girders had on the pier; but it should have been nine inches. Every girder was still in existence. The coroner pointed out that, according to the plans, the ground-floor girder should have measured 24ft. 6in., and that one which had been pointed out to the assessor by the foreman was only 22ft. 11in. in length. The difference would, he said, affect the bearings. The witness said that it was no part of his duty to see that the girders had proper bearings, but if he saw anything wrong he would immediately point it out. Mr. Simpson, his representative, was responsible for the girders being according to specification. A bearing of only 4in. would, he admitted, be improper. He noticed that many of the bricks had been crushed by the weight above. The pier measured 2ft. 6in. in thickness, and ran up to a height of 80ft. A pier of that description should be reduced as it went up. He believed there was a rule that a pier should not be carried up more than 12 times its own thickness, which in this case would have been 30ft. The Coroner: Then why did you provide for a pier 80ft. high, very nearly three times what you tell us is the recognised rule? I was told that Banks's fireproof flooring would have a good deal to do with it. The Coroner: I asked why you carried it up 80ft. instead of 30ft. Because I thought it would do. I was bearing in mind the fireproof floor which is so well tied. The fact of carrying it up to 80ft. would reduce its carrying powers. The Coroner, referring to the omission of the iron stanchion, said he thought it was a curious way of building. The witness said he was of opinion that a mass of 150 tons falling would carry with it any building. The fact that steel joists were broken was very strong evidence of the very strong pressure that had been upon them. He was of opinion that the accident happened through the falling of the concrete roof on to the sixth floor. Mr. Kent stated at this juncture that the witness had been advised to obtain legal assistance, and counsel would be instructed for his re-examination. In those circumstances he asked the coroner to allow the re-examination to stand over. This course was assented to. Mr. George Simpson, architect and surveyor, assistant to the last witness, stated that in conjunction with Mr. Pawley he superintended the construction of the building. He saw the men putting in the centring for the concrete roof. It was supported by quartering secured with bolts, the whole resting on the lacing joists of the roof. He did not give directions as to the concrete to be used. The concreting of the roof was done in one continuous job, and he should say five or six days before the collapse. Murrell's men put it in. Witness received specific instructions from Mr. Pawley not to allow the centring to be removed. He immediately passed on the instruction to Murrell. After the collapse Murrell said he had instructed his foreman not to strike the centring. No clerk of the works was engaged. He did not consider that one was necessary, as he and Mr. Pawley were looking after the building. He knew that the centring had been struck, because it was lying on the adjoining roof. Mr. William R. Rickard, 124, City-road, builder and contractor, said that about two years ago he entered into an agreement with the freeholder for the erection of the mansions, and he instructed Mr. Pawley to prepare plans and specifications. It was his own venture. The south block was not commenced on the original plans, which were altered. He was first told of the stanchion about 12 months ago. It was not ordered because an engine and some machinery had been placed where it was to go. These were removed about a week before Easter. The sub-contract for the brickwork was placed with Mr. Thorpe. Witness had no control over that. He had a sub-contractor for the flooring, and had no control over that. The same remark applied to the roof and the carpentering. Witness had control over the labourers' work. It was to his interest to see that the work was done as contracted for. The money which he had in the undertaking was advanced to him. On November 17 last he sold his interest in the concern for £1,000 profit to Mrs. Leeds, a lady residing at South Norwood, who was the freeholder. The Coroner: I understood that the freeholders were the governors of the Greycoat School? The witness replied that his freeholder was Mrs. Leeds. He was to finish the building at prime cost. There was no agreement as to the cost, but he took out the quantities and estimated the cost up to the roof at £20,000. He regarded

Mrs. Leeds as the person responsible for any damage that might occur to life and property. It did not affect his pocket if the building stood or fell after November last. He believed the concrete was to consist of four parts of coke-breeze and one part of best Portland cement. It was to be turned over once in a dry state and twice while wet, but he did not know whether that was done. The way in which the concrete was mixed was very important. The inquiry was here adjourned. At the adjourned inquest on Wednesday, Richard Martin Collins, a stonemason engaged on the south section of the building (the portion which collapsed) said he was employed by Mr. Courtney, the contractor for the stonework, and worked on the building from August last year until April 2. The brickwork was let to a Mr. Thorpe. Many of the bricks used in the internal walls were received from a job in St. James's-street, where they had been rejected. They were very soft and light. Some fell to pieces by mere handling, and were thrown into the mortar-mill. He could not swear that he saw any of the soft bricks used in the construction of the pier which supported the floor girders. The pier measured 3ft. 6in. by 1ft. 6in., not 3ft. 6in. by 2ft. 6in., as stated by the architect. Bricks and templates were consigned to Mrs. Leeds, the freeholder, and a Mr. Andrews used to sign for her. The templates supplied for the pier were not used for the pier at all. That would certainly affect the solidity of the building. When witness protested against small templates being used instead of large ones, he was jeered at and told to mind his own business. Mr. Thorpe's men fixed the girders. The principal carriage girder at the top went into a flue at both ends. He believed that a girder went right across the pier and that only two girders went through each floor. The lacing girders were never bolted up to the carriage girders when they were fixed. The lacing girders rested on the flanges of the carriage girders. Mr. Rickard, the contractor, never gave instructions. Mr. Pawley, the architect, occasionally gave directions. The building was up three or four floors before a girder was put in. The templates were put in and holes left for the girders by the bricklayers. Mr. W. J. W. Beckey, outside manager for the Banks' Fireproof Construction Syndicate, Ltd., said that that company put in the fireproof flooring. They were employed by Mr. Rickard, and never directly or indirectly by Mrs. Leeds. They employed their own men. He never put in the concrete floors until he saw that everything was right. He could not say whether all the lacing girders were bolted; but these girders were bolted on the second and third floors before the concrete was laid. By Mr. Kent: He saw the men mixing the concrete for the roof, and he thought that the way in which it was being mixed was not right. He told Andrews, the foreman, that in his opinion the way in which the men were working the stuff was scandalous. By Mr. Hudson: He could not say positively whether any of the girders were bolted or not, but he noticed nothing to prevent him from putting in the concrete. His duty was only to look to the lacing joists. The second, third, fourth, and fifth floors were concreted at the time of the accident, and witness was at work on the landings. The centring was in on the sixth floor. To Mr. Edwards: He should say the sample of concrete produced was of good quality. James Andrews, a carpenter, said he was employed by Mr. Rickard, and was general foreman of the job. He remembered alterations being made in the plans. It was decided, amongst other things, to make the brick pier a little thicker than provided for in the specification. He used his own discretion as to the way in which the templates were put in. Mr. Pawley told him to put in 4in. templates. Except for joinery he never used the specifications after the footings, although he was aware they were intended to convey instructions. He considered that as general foreman he had control over the many sub-contractors. The ironwork and concreting for the roof were contracted for by Mr. Murrell. He had told Murrell's foreman, Parker, that the concrete should be turned over at least once when dry. The Coroner pointed out that the specification said "at least twice," and said that all through the case witnesses tried to put the blame on other people. The witness, continuing, said that when the accident happened he found, much to his surprise, that the centring had been struck. The Coroner: The concrete roof had been up a fortnight; why should you be surprised?—Well, that was all I could

think of. I think concrete roofs are too heavy. In reply to further questions the witness said he heard that bricks came from another job, where they had been condemned. There were about 35,000 of them, and either Mr. Rickard or Mr. Simpson told him to do the best he could with them. Many of them were broken and soft; the whole ones were used for the internal walls, and the soft ones were put into the mortar-mill. He had never been on a job of this magnitude before without a clerk of the works being employed. The further hearing was adjourned.

At the adjourned inquiry yesterday (Thursday) Mr. W. Young, a solicitor, appeared to represent Mrs. Leeds, whose name has several times cropped up during the inquiry, and Mr. Troutbeck informed him that he wanted to get at the exact position held by that lady in relation to the building contract. James Andrews, who acted as foreman for Mr. Rickard, the principal contractor, continued his evidence. He gave a lengthy explanation of why certain alterations in the plans were made, and at the close the coroner remarked despairingly, "I daresay you know what you are talking about, but I'm sure I don't." His further evidence was postponed. Mr. Rickard produced the agreement entered into between him and Mrs. Harriet Susannah Leeds, of West Norwood, on Nov. 12 last year, under which she purchased his interest in the buildings for £1,000, and appointed him the contractor to carry on the work of erection. The case was proceeding when we went to press.

### CHIPS.

The Leeds City Council have decided to extend the overhead electric system of traction to the Headingley, Chapeltown, Hunslet, and Dewsbury-road tramway routes.

The erection of an Elizabethan mansion, stables, and lodges has just been completed for Mr. W. H. Allen, J.P., in the county of Bedfordshire. It has been built of picked Weldon stone and red local tile roof, while the finishings inside are all of oak. The garden and grounds have been laid out by Messrs. J. Cheal and Sons, of Crawley. The whole of the works have been carried out under the direction of the architect, Mr. George P. Allen, of Adelphi Chambers, London.

Notwithstanding the assurance that the Great Western Railway Company were prepared to take over and work a railway fifty miles in length, which it was proposed should traverse Wales from east to west, a committee of the House of Commons, presided over by Sir Mark Stewart, have found themselves unable to authorise the raising of capital to the amount of £933,000.

On Sunday week the Bishop of Truro opened All Saints' Church, Bryher, Isles of Scilly, which has undergone a complete restoration. The church, situated close to the beach, succeeded, in 1821, a diminutive and unique structure erected about 1741. In 1860 the present edifice was renovated by the late Mr. Augustus Smith, and a tower and porch were added. The east end has now been entirely rebuilt, while the exterior of the building has been pointed.

A bust of the late Mr. Greig Smith was unveiled on Saturday evening at the Museum, Bristol. It has been executed by Mr. Ernest Fabian, modelling master at the Bristol School of Science and Art, Queen's-road.

A large landslip, involving the fall of many thousand tons of cliff, occurred opposite Cromer Lighthouse on Saturday afternoon. Fortunately, no one was injured. The earth covers the beach up to low-water mark. It is stated that some men who had been at work on the sea groyne lost some of their tools and clothing as a result of the slip. The site marked on the cliffs for Lloyd's signal station is now only some thirty yards from the edge of the cliff.

The Earl of Jersey, Colonel Boughey, and Mr. G. A. R. Fitzgerald, Light Railway Commissioners, sat at the Council Chamber, Salisbury, on Saturday, to hear an application from the London and South-Western Railway Company for powers to construct a light railway across Salisbury Plain, commencing at a point on the main line between Porton and Grateley, and proceeding by way of Amesbury to Shrewton. Mr. Andrews, engineer, stated that the line was 10½ miles long, and would cost about £60,000 in construction. The War Office were entirely in favour of the proposal, and in addition the company had the support of the landowners and inhabitants of the district affected. In the end the Earl of Jersey said the Commissioners were prepared to recommend the Board of Trade to sanction the construction of the line subject to further negotiations on the points raised as to bridges and level-crossings.

### OBITUARY.

MR. HARRISON HAYTER, Past President of the Institution of Civil Engineers, who died on Thursday in last week, at his residence, 61, Addison-road, Kensington, at the age of 73 years, was one of the most prominent civil engineers in this country. In 1857 he joined the late Sir John Hawkshaw, who held in 1862-3 the Presidency of the Institution of Civil Engineers, as his principal assistant; in 1870 he was admitted as a partner with him, and continued his long and honourable professional career in connection with Sir John until the latter's retirement from business in 1888. At the date of his death Mr. Hayter was engaged, in company with his partner, Mr. J. C. Hawkshaw, in carrying out in Argentina a large system of docks at Buenos Ayres. Mr. Hayter had been a member of the Institution of Civil Engineers since May, 1862, and served as president in 1892-3.

MR. FRANK WILLOUGHBY BRIND, architect, of 5, John-street, Bedford-row, W.C., died on Sunday last at his residence in Kensington, from acute pneumonia, at the early age of 32 years. Mr. Brind was the only surviving son of Mr. and Mrs. Frederick W. Brind, of Maze Hill, St. Leonards-on-Sea.

At Tue-day's meeting of the Bristol City Council a letter was read from Sir W. H. Wills, Bart., M.P., offering to present to the city a picture by P. R. A. Müller, now on view at Messrs. Frost and Reed's gallery in Clifton, towards the establishment of a municipal art gallery. The offer was accepted with thanks.

The Unopposed Bill Committee of the House of Commons have passed the Bill authorising the Mersey Docks and Harbour Board to extend and improve their docks, basins, and works on the Liverpool side of the River Mersey. These works comprise the construction of five branch docks and three graving docks, and the enlargement and improvement of six existing docks. This Bill, which has already passed the House of Lords, will involve the expenditure of £3,562,000.

A large saw-mill, at Esplanade, Dundee, and tenanted by Mr. Thos. Winton, was destroyed by fire on Sunday. The mill contained much valuable machinery, and oak, ash, and elm wood. The damage is estimated at £3,000.

Mr. Henry Augustus Robinson, C.B., has been appointed Vice-President of the Local Government Board in Ireland, in the room of Sir George Morris, who has retired under the age rule. Mr. Robinson was formerly one of the Board's inspectors, and more recently one of the members of the Board. Mr. William Lawson Micks and Mr. Thomas Joseph Stafford have been appointed Commissioners on the Board.

The foundation-stone of a new church, dedicated to St. Hildeberg, was laid on Saturday in Stanley-road, Hoyleake. Lord Stanley of Alderley presented the site, and also the sedilia and marbles. Plans were made by the architect, Mr. Edmund Kirby, F.R.I.B.A., for a complete church, and the committee began by building the nave as a first section on the tender of Mr. William Winnard, of Wigan. The cost of the building will be about £6,000, and it will provide accommodation for about 500.

The London County Council discussed at great length on Tuesday the recommendation of the General Purposes Committee to extend the radius within which, under the Council's contracts, London rates of pay and number of hours of work should be the rule from twelve to twenty miles, thus reverting to the arrangement in force before November last. Sir Arthur Arnold made a strong protest against the proposal, which was generally opposed by the Moderate Party, on the ground that the Council should be enabled, in the interests of the ratepayers, to take advantage of the lower rates of pay in country districts. The report was, however, adopted by 71 to 48 votes.

The new fever hospital, Westhulme, Oldham, is being warmed and ventilated by means of Shorland's patent Manchester stoves, with descending smoke-flues, and Shorland's patent Manchester grates, the same being supplied by Messrs. E. H. Shorland and Brother, of Manchester.

At a meeting of the Bridgend and Cowbridge guardians on Saturday the workhouse alterations committee recommended that the sketch plans prepared by the architect (Mr. P. J. Thomas, Bridgend) be presented to the board to-morrow (Saturday.) It is proposed to acquire an additional acre of land adjoining the present building for about £1,000, and to erect thereon a new infirmary, with accommodation for from 80 to 100 beds, as well as to carry out extensive alterations in the present building. The total cost is estimated at from £15,000 to £20,000.

## Building Intelligence.

BOLTON.—Memorial-stones were laid on Friday of the Victoria Central Wesleyan Mission Hall, Bolton. The Victoria Hall proper, as distinct from its adjuncts, will accommodate 2,000 people, and will, in fact, be the largest building in Methodism. It occupies the site of the old Ridgeway Gates Chapel, and a new frontage has been made to Knowsley-street. The entrance to the whole of the buildings will be in Knowsley-street. One of the shops will be converted into an entrance hall, and a tower will be built over this to the height of 90ft. A spacious vestibule is provided, having an inquiry office, and to right and left broad staircases to the gallery of the hall. Beyond these, through a double archway, are the staircases to the lower floor. Past these staircases are the doorways to the main floor of the Victoria Hall, on the level of Knowsley-street. The centre part of the floor is sloped from front to back, and at the sides the seats are arranged tier above tier, so that everyone can have an uninterrupted view of the platform. The gallery has five tiers of seats at the sides, and twelve tiers at the back. The hall will be 117ft. long and 72ft. broad. As externally it will be very little seen, with the exception of the entrance tower, it will be severely plain. The internal roof will be arched and panelled with coved sides over part of the gallery. The windows will have arched heads, and will be filled in with painted glass. The platform recess will be arranged with broad pilasters and corbelled beams, the back being coved. The platform itself will be large enough for an orchestra and choir, and its front will be brought forward and rounded. The whole of the buildings will be lighted by electric light. Messrs. Bradshaw and Gass, of Bolton, are the architects, and the total cost, including additional land, will be between £20,000 and £30,000.

BURY, LANCS.—The United Methodist Free Church, Parkhills-road and Horne-street, was formally opened yesterday (Thursday). The church consists of a simple nave, but is broken at the east end into chancel, and north and south transepts, which are partly in the church, and for the rest contain vestries with galleries over. The chancel and the vestries flanking it are three steps above the floor of the church. The east end is apsidal. The building is designed in a Late period of Gothic architecture. The nave windows are not pointed, but segment-headed broad openings, filled in with three compartments as regards the lower part, the upper being divided into a number of lancet openings. The other windows are pointed and traceried. All are filled in with lead lights. The tower is surmounted by a slender flèche covered with copper tiles. The dimensions of the chapel are 80ft. by 37ft. 6in. The chancel opening is 22ft. wide, and the depth of the chancel is 17ft. 6in. The height from floor to eaves is 17ft., from floor to highest point of ceiling 36ft., and floor to base of vane on tower 60ft. The accommodation provides for 487 sittings, inclusive of choir and west gallery. The materials used in the erection are, outside, brickwork, faced with plastic county bricks; inside, plastic bricks, by Mr. Samuel Knowles, of Holcombe Brook. Yorkshire stone is used for the sills, bands, &c., and the slates are of green Westmoreland. The interior woodwork is of figured pitch-pine throughout. The contract price was £2,500. The contractors are Messrs. Thompson and Brierley, and the architect is Mr. J. D. Mould, F.R.I.B.A., of Bury, Manchester, and London.

LEAMINGTON.—The foundation-stone of the new wing of the Warneford Hospital, Leamington, was laid on Friday, with full Masonic honours, by Lord Leigh. The wing is part of the original design for the extension of the hospital, and was last year adopted by Leamington as the local scheme for the commemoration of the Queen's Diamond Jubilee. The new structure, for which Messrs. Young and Hall, London, are the architects, will be built on the pavilion principle. The cost of the contract is £8,760. The wing will accommodate thirty-two additional patients, but the number of beds in the hospital will not be increased to this extent, as room will be found in the new wards for some of the patients who are at present treated in the old buildings, where the hygienic conditions are not wholly satisfactory. When the new wards are completed the entire capacity of the hospital will be increased to 125 beds.

## CONTENTS.

Irresponsible Building	659
Pictures at the Royal Academy	659
Model Specifications.—XII.	660
Electric Lighting Notes for Architects.—XXIII.	662
The Architectural Association	664
Ironwork at South Kensington Museum	666
The Rise and Development of the Portland Cement Industry	667
The Book of Glasgow Cathedral	667
The Surveyors' Institution	668
The Passmore Edwards Homes for Epileptics, Chalfont St. Peter's	668
The Collapse of the Roof of Abbey Mansions, Westminster	668
Obituary	670
Building Intelligence	670
The Building News Directory	671
Our Illustrations	671
Competitions	671
Correspondence	690
Intercommunication	690
Professional and Trade Societies	691
Our Office Table	692
Meetings for the Ensuing Week	693
Trade News	693
List of Competitions Open	694
List of Tenders Open	694
Tenders	696
Latest Prices	696

## ILLUSTRATIONS.

PROPOSED R.C. CHURCH OF ST. AUGUSTINE, NOTTINGHAM.—GLASGOW CATHEDRAL.—THE COURT HOUSE, BROADWAY, WORCESTERSHIRE.—A COUNTRY HOUSE AT SUTTON.—DESIGN PLACED THIRD FOR ROYAL MASONIC SCHOOL FOR BOYS AT BUSHEY.—CENTRAL FIRE STATION, BOOTLE.
--------------------------------------------------------------------------------------------------------------------------------------------------------------------------------------------------------------------------------------------

## Our Illustrations.

## R.C. CHURCH OF ST. AUGUSTINE, NOTTINGHAM.

This church is shortly to be erected on a somewhat limited site in the Woodbro' road, Nottingham. The building will be built of local bricks and red Corsehill stone. The interior will be faced in stone. The plan explains the general arrangement, but it may be noted that the rapid fall of the street lends itself to the provision of the necessary vestries under the chancel. Mr. Arthur Marshall, A.R.I.B.A., of Nottingham, is the architect. The drawing is on view at the Royal Academy Exhibition.

## GLASGOW CATHEDRAL.

(For description, see page 667).

## THE COURT HOUSE, BROADWAY.

This house, situated in the Cotswolds, some half-mile out of Broadway, is now being built, and incorporated with the new house is the old gatehouse or porter's lodge, which once belonged to the seat of the Sheldon family, who had a beautiful house here in the 17th century. This mansion has now all disappeared, having been used as a quarry for building purposes some long time since. The gatehouse, with its wide archways, dates from about the first quarter of the 17th century, and is interesting as combining in the plan and general detail the earlier traditional work, yet in the semicircular arches of the entrance, the Classical feeling of the impost mouldings, pilasters, and cornices, the effect of the Renaissance is seen. The new house does not aim in any way at being original, as it was felt that the old work should give the keynote of the composition, and effect has been gained by quiet grouping and detail in character with the simple work of the district. The architects are Messrs. E. Guy Dawber and Whitwell, and the contractors Messrs. Cowlin and Son, of Bristol. The drawing is at present in the Royal Academy Exhibition.

## COUNTRY HOUSE, SUTTON.

The chief feature of this building calling for remark is the large central hall running up two floors with a gallery at one end. The hall also serves the purpose of a billiard-room, and this arrangement is an economical method of obtaining a good hall, which otherwise could not be had without a considerable increase in the cost. Another pleasant feature in the planning is the garden entrance below the staircase, through which can be obtained a pretty glimpse of the garden from the hall. The materials are red brick and stone facings to the large hall window. Portions of the upper parts and walls are finished with rough timbering and plaster, the timber being treated with Stockholm tar. The roof is to

be finished with brindled tiles. The architect is Mr. Ernest Runtz. The illustration is from a drawing now at the Royal Academy.

## ROYAL MASONIC SCHOOL FOR BOYS, BUSHEY, HERTS.

ILLUSTRATIONS of the selected design for this great Masonic Institution about to be erected at Bushey were published in our pages for 11th March last. The original drawing of the perspective view is now at the Royal Academy Exhibition. To-day we give a bird's-eye view and copy of the plan which was, we understand, placed third in order of merit in the referee's award. The joint authors of this design were Mr. J. Morley, architect, Cambridge, and Mr. W. J. Tapper, of Gray's Inn, W.C., Mr. H. S. East, of the latter address, being associated with them.

## CENTRAL FIRE STATION, BOOTLE.

The accompanying view is reproduced from the original drawing by Messrs. Briggs and Wolstenholme, of Liverpool and Blackburn, whose design was placed second by the assessor in the recent competition; 22 architects submitted plans. It was proposed to face the buildings with red brick and buff terracotta dressings. The limit of cost laid down by the town council in their instructions to architects was £15,000.

## CHIPS.

At Monday's meeting of the Wolverhampton Town Council, it was decided, as the recommendation of the Public Works Committee, that the work of demolishing the Exchange Hall to the level of St. Peter's churchyard be proceeded with at a cost of £1,855. The porch in Exchange-street will be removed, the lower portion of the building be utilised as a refrigerator, and the roof of the vaults will be laid out as an open space, paved with rock asphalt, fenced with stone balusters, and ornamented with trees in tubs.

A gravitation water supply, which has been provided under county council auspices, for the combined special water districts of Kilmaurs and High Fenwick, was formally inaugurated on Saturday. The supply is wholly obtained from springs on the lands of South Drumby, situated about four miles beyond the village of Fenwick. The whole works were carried out to the design and under the superintendence of Mr. P. Campbell Hart, A.M.I.C.E., of Kilmarnock and Glasgow, at an outlay of £4,200.

On Monday the ceremony was performed of unveiling a tablet in the south aisle of the nave of St. Thomas Church, Exeter, to the memory of the late Mr. Henry Stokes, who occupied the position of organist for several years. The tablet, which is placed near the organ, has been executed by Messrs. J. Easton and Sons, of Northernhay-street, Exeter, and is of pure statuary marble with black marble back.

A school for deaf mutes, erected by the Bristol School Board, in Kingston-parade, in that city, was opened on Tuesday. It has been built from plans by Mr. L. Bernard, F.R.I.B.A., and has cost for site and building about £150 per head for the 31 children to be taught within it.

Messrs. Christie, Manson, and Woods sold on Tuesday the small but choice collection of works of art of the 16th century, of the late Mr. T. M. Whitehead, of Cedars-road, Clapham-common. One hundred and forty-eight lots realised the total of £7,216 18s. 6d.

The Chesterfield Board of Guardians have decided, the old workhouse having been condemned by the Local Government Board officials, to build a new workhouse on a site in Ashgate-road.

The Monmouthshire County Council have decided to sanction the expenditure of about £5,000 for carrying out some temporary building works at the asylum, Abergavenny.

The sale of the Heckscher collection of works of art was concluded at Messrs. Christie, Manson, and Woods's on Friday, the interest and keen competition being kept up to the last lot. The total realised by the 324 lots amounted to £64,705 10s., which works out at an average of £200 per lot—one of the very highest averages ever realised by any collection of a like character. The first day's sale averaged nearly £280 per lot. Mr. Heckscher, who died in Paris twelve months ago at the age of 58, was born and partly educated in London. He was connected with the insurance business.

The Corporation of Derby received on Friday two gifts as custodians for the town. One is a portrait of Sir Thomas Roe, father of the corporation, twice mayor, and for many years one of its Parliamentary representatives. The other gift consisted of twelve water-colour drawings and five oil pictures by well-known artists, from Colonel T. H. Sale, R.E., of London.

## COMPETITIONS.

GLASGOW INTERNATIONAL EXHIBITION.—The draft conditions of the competition for designs for the exhibition buildings at Glasgow state that the space to be covered is thirteen acres or thereby, and the total cost of the buildings, inclusive of the dining and refreshment rooms, but exclusive of the grand hall, is not to exceed £60,000. The grand hall, which is to seat about 4,000 persons, is to be apart from the main building, and may be estimated for separately.

GODALMING MUNICIPAL BUILDINGS.—The municipal buildings committee recommended to the town council at its last meeting that the sum of £25 be paid to Mr. S. Welman for his trouble in surveying and reporting upon the various sites suitable for municipal buildings. They further recommended that the following firms or architects be invited to compete for the proposed buildings—viz., Ardrow and Dawson, Westminster; Charles Bell, London, E.C.; Colson, Farrow, and Nisbet, Winchester and London; John Jackson, London, E.C.; Lancheater Stewart and Rickards, London, W.C.; Henry Moon, Godalming; E. R. Robson, Westminster; J. W. Stevens, London, E.C.; A. H. Tiltman, London, W.C.; A. H. Verstage, Godalming; Samuel Welman, Godalming; and Woodhouse and Willoughby, Manchester; and that Mr. E. W. Mountford, F.R.I.B.A., be appointed assessor at a fee not exceeding twenty-five guineas. The recommendations were adopted.

LUDLOW.—The town council recently received ten competitive schemes for lighting the borough by electricity, and have awarded the premium of £20 to Mr. Enwright, of Kensington. A committee reported to the council that they were disappointed to find that the mill-power was not sufficient to drive an electric-light plant. Of the ten schemes received only two exclusively dealt with the water-power, and these in such a way as to interfere with the waterworks power. They could not entertain a scheme which would interfere with the water-supply. Mr. Enwright's scheme proposed to use gas for driving power. The idea was to erect a Dowson's patent gas apparatus to provide its own gas, and to lay down two engines of 54 H.P., which would be sufficient to provide light for six or seven hours a day for the whole borough. It was proposed to erect the plant in the Cattle Market, with a main feeder to the Butter Cross, from whence the mains would be distributed. The total expenditure for this scheme was £5,000, the estimated annual cost to the corporation was £650, and the estimated annual revenue £1,300, yielding a profit of £500 or £600 a year. Mr. Enwright also stated he would find a contractor to carry out the work at the figures named. The report was adopted.

TAUNTON TOWN HALL.—It was reported at the last meeting of the market trustees that thirteen architects had sent in plans in connection with the competition for providing designs for a new town hall. They are to be adjudicated upon by Mr. E. W. Mountford, F.R.I.B.A., of London, and will be exhibited in the Parade Assembly Rooms.

WESTON-SUPER-MARE.—A special meeting of the School Board was held on Monday afternoon for the purpose of selecting one of the five competitive plans sent in for the new Board school to be erected in the Locking-road. Plan No. 5 received the unanimous approval of the board, and the architects proved to be Messrs. Hans F. Price and S. J. Wilde, of Weston.

WINCHESTER.—At the last meeting of the city council, the public baths committee reported that 24 plans for the proposed baths had been sent in, and they had secured the services of Mr. Jones, of Eling, as assessor to advise the committee upon the monetary awards for the best plans submitted. A short debate ensued as to the desirability of the public inspection of the plans prior to Mr. Jones making his awards, and in the result an amendment was carried by 15 votes to 6 votes that the public be permitted to inspect the plans at once, and the General Purposes Committee were directed to make arrangements for exhibiting the same at the Sessions Hall.

The memorial tower and six cottage homes, which have been built at Mauchlins, Ayrshire, as a memorial to the poet Burns, were inaugurated by Mr. J. G. A. Baird, M.P., on Saturday. They have been built from designs by Mr. William Fraser, of Glasgow, and were illustrated in the BUILDING NEWS for Jan. 22, 1897.

# CENTRAL FIRE STATION, BOOTLE.





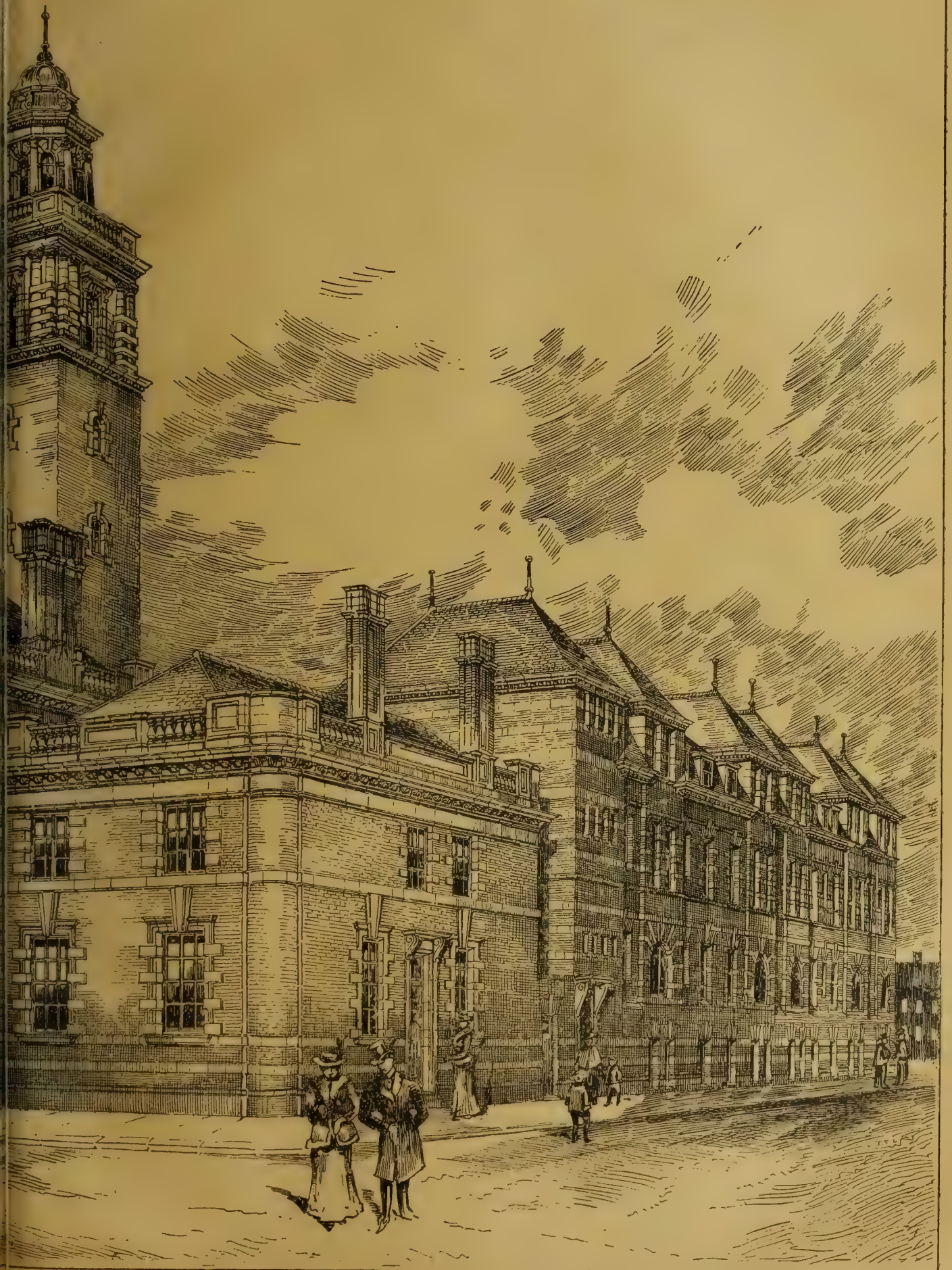

TO CORRESPONDENTS.

[We do not hold ourselves responsible for the opinions of our correspondents. All communications should be drawn up as briefly as possible, as there are many claimants upon the space allotted to correspondents.]

It is particularly requested that all drawings and all communications respecting illustrations or literary matter should be addressed to the EDITOR of the BUILDING NEWS, 332, Strand, W.C., and not to members of the staff by name. Delay is not infrequently otherwise caused. All drawings and other communications are sent at contributors' risks, and the Editor will not undertake to pay for, or be liable for, unsought contributions.

Cheques and Post-office Orders to be made payable to THE STRAND NEWSPAPER COMPANY, LIMITED.

TERMS OF SUBSCRIPTION.

One Pound per annum (post free) to any part of the United Kingdom; for Canada, Nova Scotia, and the United States, £1 6s. 0d. (or 6dols. 80c. gold). To France or Belgium, £1 6s. 0d. (or 33fr. 30c.) To India, £1 6s. 0d. To any of the Australian Colonies or New Zealand, to the Cape, the West Indies, or Natal, £1 6s. 0d.

ADVERTISEMENT CHARGES.

The charge for Competition and Contract Advertisements, Public Companies, and all official advertisements is 1s. per line of Eight words, the first line counting as two, the minimum charge being 5s. for four lines.

The charge for Auctions, Land Sales, and Miscellaneous and Trade Advertisements (except Situation advertisements) is 6d. per line of Eight words (the first line counting as two), the minimum charge being 4s. 6d. for 40 words. Special terms for series of more than six insertions can be ascertained on application to the Publisher.

Front-page Advertisements 2s. per line, and Paragraph Advertisements 1s. per line. No Front-page or Paragraph Advertisement inserted for less than 5s.

Advertisements for the current week must reach the office not later than 3 p.m. on Thursday. Front-page Advertisements and alterations in serial advertisements must reach the office by Tuesday morning to secure insertion.

SITUATIONS.

The charge for advertisements for "Situations Vacant" or "Situations Wanted" is ONE SHILLING FOR TWENTY-FOUR WORDS, and Sixpence for every eight words after. All Situation Advertisements must be prepaid.

NOTICE.

Bound copies of Vol. LXXIII. are now ready, and should be ordered early (price Twelve Shillings each), as only a limited number are done up. A few bound volumes of Vols. XXXIX., XL., XLI., XLII., XLIII., XLIV., XLV., XLVI., XLVII., XLVIII., XLIX., L., LI., LII., LIII., LIV., LV., LVI., LVII., LVIII., LIX., LX., LXI., LXII., LXIII., LXIV., LXV., LXVI., LXVII., LXVIII., LXIX., LXX., LXXI., LXXII. may still be had, price Twelve Shillings; all the other bound volumes are out of print. Most of the back numbers of former volumes are, however, to be had singly. Subscribers requiring any back numbers so complete volume just ended should order at once, as many of them soon run out of print.

RECEIVED.—J. F. C.—Chas. Farrant.—C. P. and Co.—Donald D.—E. C. H.—Perplexed.—N. W.

"BUILDING NEWS" DESIGNING CLUB.

EIGHTH LIST OF SUBJECTS.

H.—A Cottage Home for Waifs and Strays on a level site in the country. This dwelling is to be designed to accommodate 24 poor boys, with rooms for a matron, a nurse, and two servants. There is to be a day-room, 20ft. by 16ft.; dining-room, 24ft. by 18ft.; two dormitories of 12 beds each; a bath-room, with two baths; four water-closets and urinals in an annex adaptable for day or night use, a box-room, a boot-room, kitchen and scullery, lamp-room and oil-shed. A sitting-room for matron to be provided, and on first floor three bedrooms for the staff and a sick-room for two boys; a bath-room and w.c. also on first floor; servants' w.c. in house yard; pantry and larder; a small play-shed on the south side of the building is to be contrived. The dimensions given may be varied provided the superficial areas in each case are not less than those mentioned herein. Materials: red brick and stone sparingly used, roofs to be tiled, and upper walls may be plastered or tile-hung. Scale, 8ft. to the inch. Plans may be smaller. Sufficient drawings to illustrate the proposed, including a sketch view.

DRAWINGS RECEIVED.—"Centaur," "Byd," "Dachs," "Hotspur," "Pantile."

Correspondence.

MUDDLED, AS USUAL!

To the Editor of the BUILDING NEWS.

SIR,—My filled-in voting paper for the coming election has been returned to me, with the inclosed letter and a stamped envelope, but no fresh voting list! This, I understand, is to follow! A triple postage will thus have to be charged upon something like 2,000 papers.

There are this year no less than eleven new candidates whose prospect of success lies chiefly in an increase in the number of voters; but this serious mistake is calculated to deter many voters from taking a further interest in the matter.

Last year not more than a fourth of the whole number of members voted.—I am, &c.,

May 11. FELLOW, R.I.B.A.

[COPY.]

DEAR SIR,—An unfortunate error having been discovered in the voting papers, of which printed notice will be sent in a day or two, I beg to return your envelope, together with a fresh one, in case you may have been misled.

In the directions for voting for "Members of Council" at least eleven names must be erased, instead of "ten," as printed, so as to return the maximum of eighteen.

With many apologies for troubling you,—I am, dear Sir, yours faithfully, W. J. LOCKE, Secretary, 9, Conduit-street, London, W., May 10.

Intercommunication.

QUESTIONS.

[11946.]—Hot-Water System.—Can some of your correspondents tell me if such a hot-water system as is shown in the accompanying sketch would be effective and satisfactory? I propose to do away with the usual cylinder and pipes to and from it, and to have what is practically an open boiler (which shall also be a reservoir for hot water), carried up the whole height of the building, where the water is required, as shown on sketch. The only doubt that I have about the working of such an arrangement is as to the circulation of the water in the long vertical reservoir. Of course, without circulation

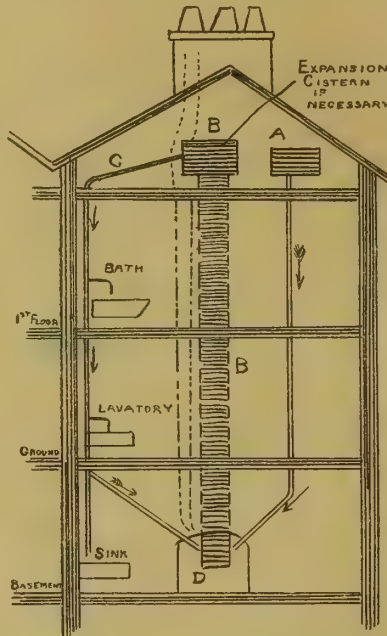

A, cold-water cistern; B, boiler and reservoir; C, circulating loop, as is usual; D, kitchen fireplace. The kitchen smoke-flue to be carried up next to the reservoir B.

there would be no hot water. It seems to me that if the method which I have suggested were carried out, there would be no more explosions, as boilers could be carried up straight and left perfectly open and free at the top, and also there would be no pipes to a cylinder to stop up and corrode. I should very much like to hear what a competent person would say about the matter. The idea may not be new, but I have never heard of it before. The system proposed is different to the old and inefficient method of having the hot-water cistern in the roof and connecting it by pipes to the boiler, inasmuch as the boiler is to be carried up the full size, and that there are no pipes. A properly prepared "chase" should be formed in the wall for reception of reservoir; the heat could be utilised.—H. M. X.

[11947.]—District Surveyor's Duties.—Is it part of the duty of a district surveyor under the L.C.C. to see that the forecourts of houses abutting on both sides of a new street are kept at the same level, so that when the road and paths are made and taken over by the parish one path and side of such road shall not be higher than the others, or is this the duty of the local authority? Is not the district surveyor concerned solely in seeing that the provisions of the Building Act are complied with? Does the Act of 1894 confer any powers, or place any responsibilities, on district surveyors, as to the levels of new houses abutting on new streets, except, of course, in cases where in marsh districts the site of such houses would be below high-water mark?—COUNCILLOR.

REPLIES.

[11945.]—Municipal Engineer's Qualifications.—"A Young Surveyor," not having had municipal experience and desiring to qualify for a municipal engineership, would require a few years' experience in a district [council] or borough surveyor's office, preferably the latter. He should pass the examination of the Municipal and County Engineers' Association. In view of gaining general experience, in the first instance, seek an appointment in the office of a surveyor acting

for some rapidly-increasing borough or urban district, rather than in a large city, where the work is usually done on strictly departmental lines, which results in training men for one kind of work only. Experienced, capable men of that class have tried for twenty years to secure borough surveyorships in smaller towns without success, although they have been selected candidates on many occasions, just because the least cross-examination as to their experience proved that they possessed but a partial knowledge of the multifarious duties of a borough surveyor, who is expected to be an architect, civil engineer, surveyor, and valuer, possessed of a deep insight into various phases of human nature, and other qualifications innumerable, if he is to succeed. The position is likely to improve.—ONCE AN ASPIRANT TO THE POSITION.

[11940.]—The New Incandescent Light.—Like "E. T." I have got tired of the incandescent lights with mantles. I think he will find the burner he refers to suit him. It is an argand burner, as shown, and has two chimneys, and a small expansion and heating-chamber just below the burner proper. The air supply is heated in passing down between the two chimneys, and the expansion chamber, which is filled with filtering material, aids in heating the gas. The flame is steady and white, but not ghastly white or green. It is supplied by Billing's Burner Syndicate, 180, Wardour-street, W. There is no smoke with the burner, no mantle, and no bother.—PYRAMID.

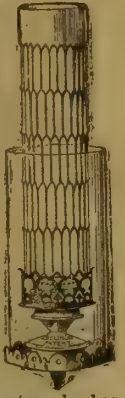

[11941.]—Gold Coast.—Having served several terms of residential service in the Public Works Department on the Gold Coast, West Africa, under the Crown Agents for the Colonies, I shall be glad to furnish accurate information of the duties, life, associates, appertaining to appointments to any gentleman from this country who has serious thoughts of offering himself for a post in the above department. Address by letter (inclosing stamped envelope)—B. A. CHRISTIE, Post Office, Clacton-on-Sea.

CHIPS.

A Local Government Board inspector held an inquiry at Lowestoft on Wednesday in connection with an application of the town council for leave to borrow £1,300 for sea defence works and £2,200 for the purchase of the south beach. Great interest was manifested in the proceedings, the project being keenly opposed by a section of the ratepayers.

The foundation-stone of a new Congregational Church was laid in Prince's-avenue, Spring-bank, Hull, on the 5th inst. It will be cruciform on plan, having a nave of 82ft. in length by 28ft. in width, with north and south transepts 18ft. 8in. and 15ft. 6in. in depth respectively, and 23ft. 6in. in width. The buildings are designed in the Late Gothic style, and the church will be seated so as to accommodate 585 persons on the ground floor, and 68 in the gallery.

At Hales Owen, on Friday, Colonel A. S. Darnford held an inquiry on behalf of the Local Government Board into the application of the district council for sanction to borrow £1,250, for the purchase and adaptation of the police buildings as public offices.

Mr. F. H. Tulloch, M.Inst.C.E., Local Government Board inspector, held an inquiry at the corporation offices, Bank-street, Bury, Lancs, on Thursday in last week, into the application of the Bury Corporation for the Local Government Board's sanction to borrow £25,000 for works of private street improvement. Mr. Cartwright, borough engineer, explained the plans.

Memorial-stones of a Wesleyan Church at Westbourne, Bournemouth, were laid on Wednesday week. The new building, with the schools adjoining, will cost £5,000. Seating accommodation will be provided for about 500 worshippers. The architect is Mr. Curwen, of London; and the builders are Messrs. F. Hoare and Sons, of Bournemouth.

The proposed improvements at Mablethorpe were the subject of a Local Government Board inquiry on Tuesday in last week. The cost of the tunnel head works was estimated at £1,321, the promenade behind the tunnel head at £259, the cab-stands, urinals, &c., £483, and the promenade from the tunnel head to the Pullover at £668, making a total of £2,711. Towards this the contribution of the Commissioners of Sewers will be £800.

The British Institute of Certified Carpenters visited St. Paul's Cathedral on Saturday afternoon. In the evening a meeting was held in the Carpenters' Hall, when Mr. T. M. G. Lloyd read a paper on "Some East Anglian Churches."

The Bewdley Corporation are proposing to reconstruct the wall on the south side of Bewdley Bridge, and to improve the quay. For this purpose they have applied to the Local Government Board for power to expend £1,000 on the work, and on Saturday Colonel Darnford, R.E., held an inquiry into the matter. The town clerk, Mr. Stanley Hemingway, explained what the corporation proposed to do if the expenditure were sanctioned. Mr. Berrington, C.E., gave evidence in support of the application, which was opposed by several residents.



THE BUILDING NEWS, MAY 13, 1898.

THE COURT HOUSE, BROADWAY,  
WORCESTERSHIRE.  
E. CUY DAWBER & WHITWELL,  
ARCHITECTS.

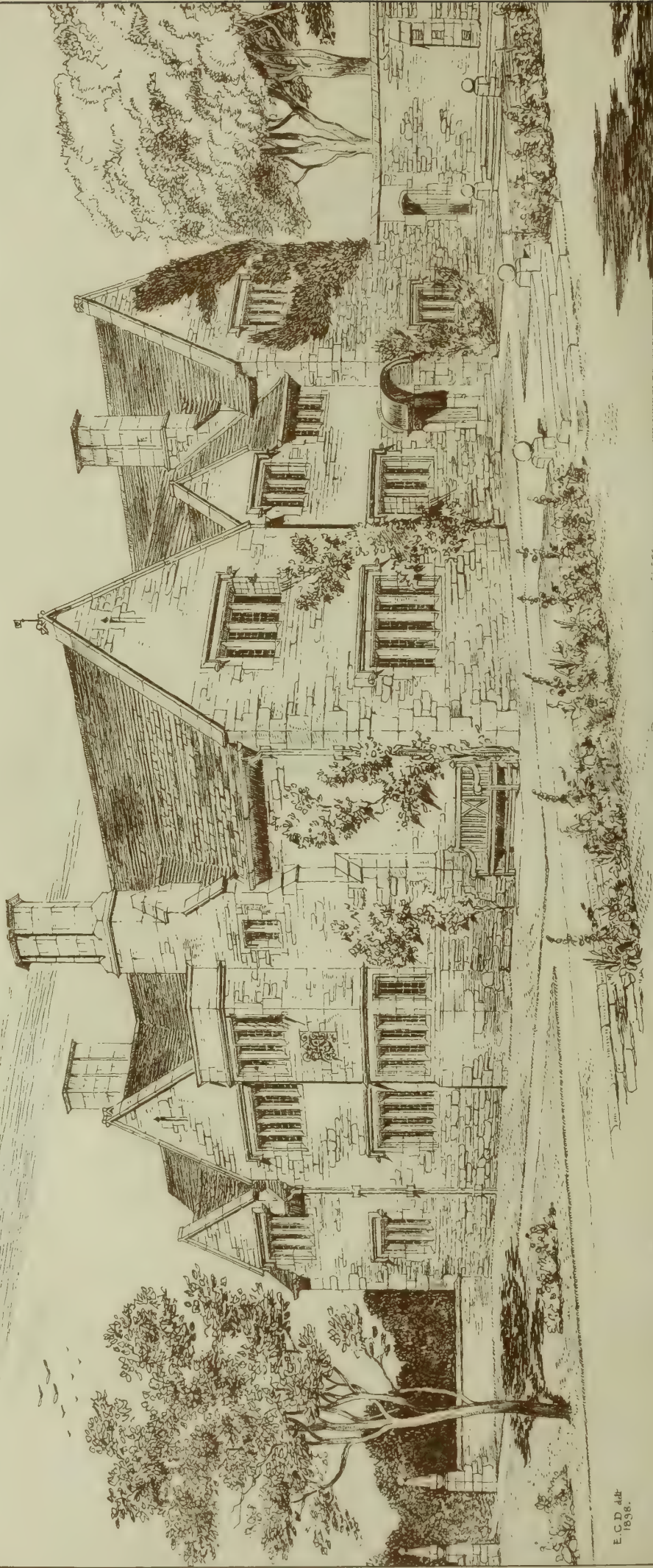

E. C. D. ARCHT.  
1898.

GROUND FLOOR PLAN

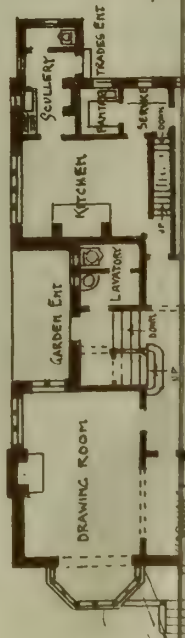



Scale 10' = 1" 0 20 40 60 80 100 Feet

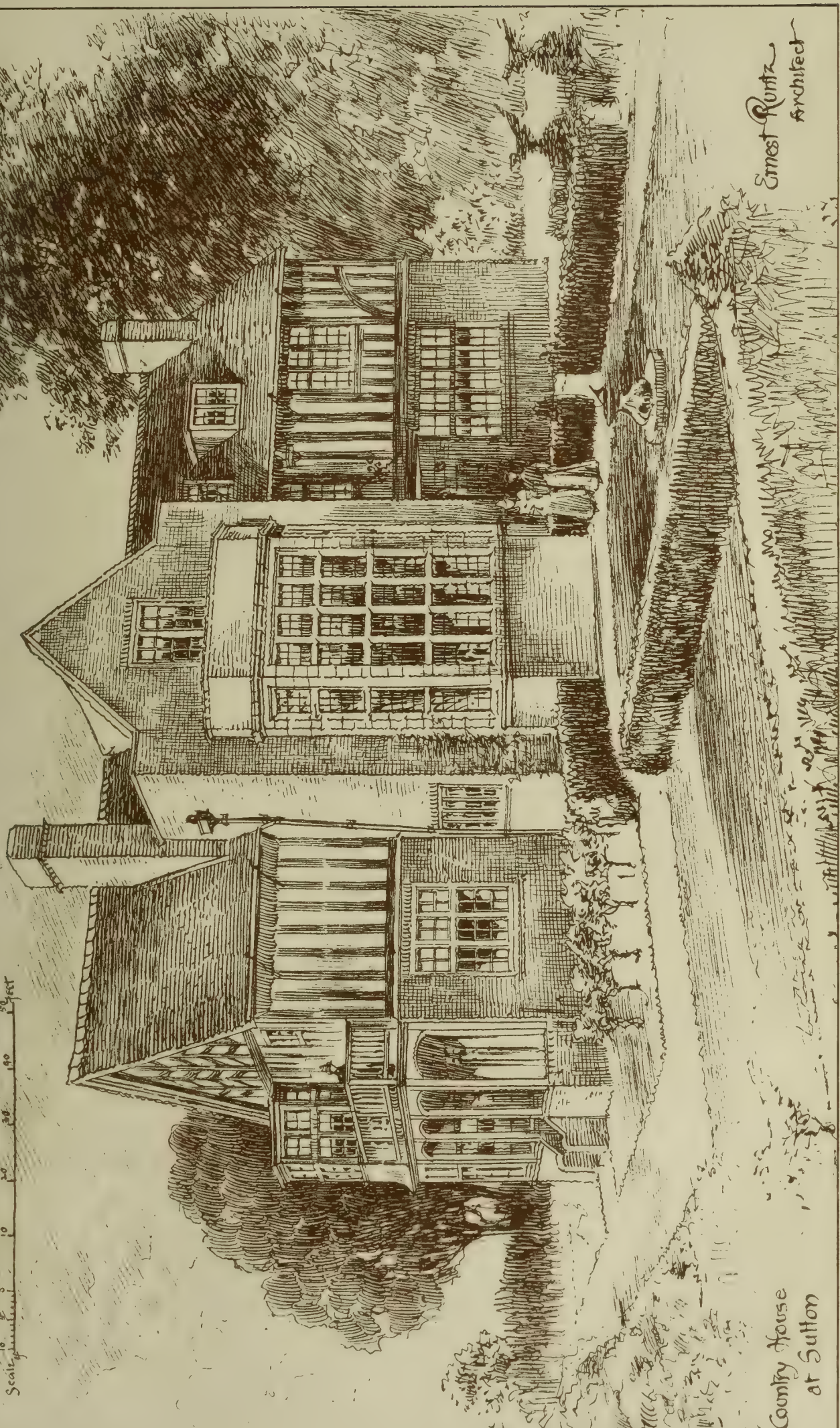

Ernest Runtz  
Architect

Country House  
at Sutton





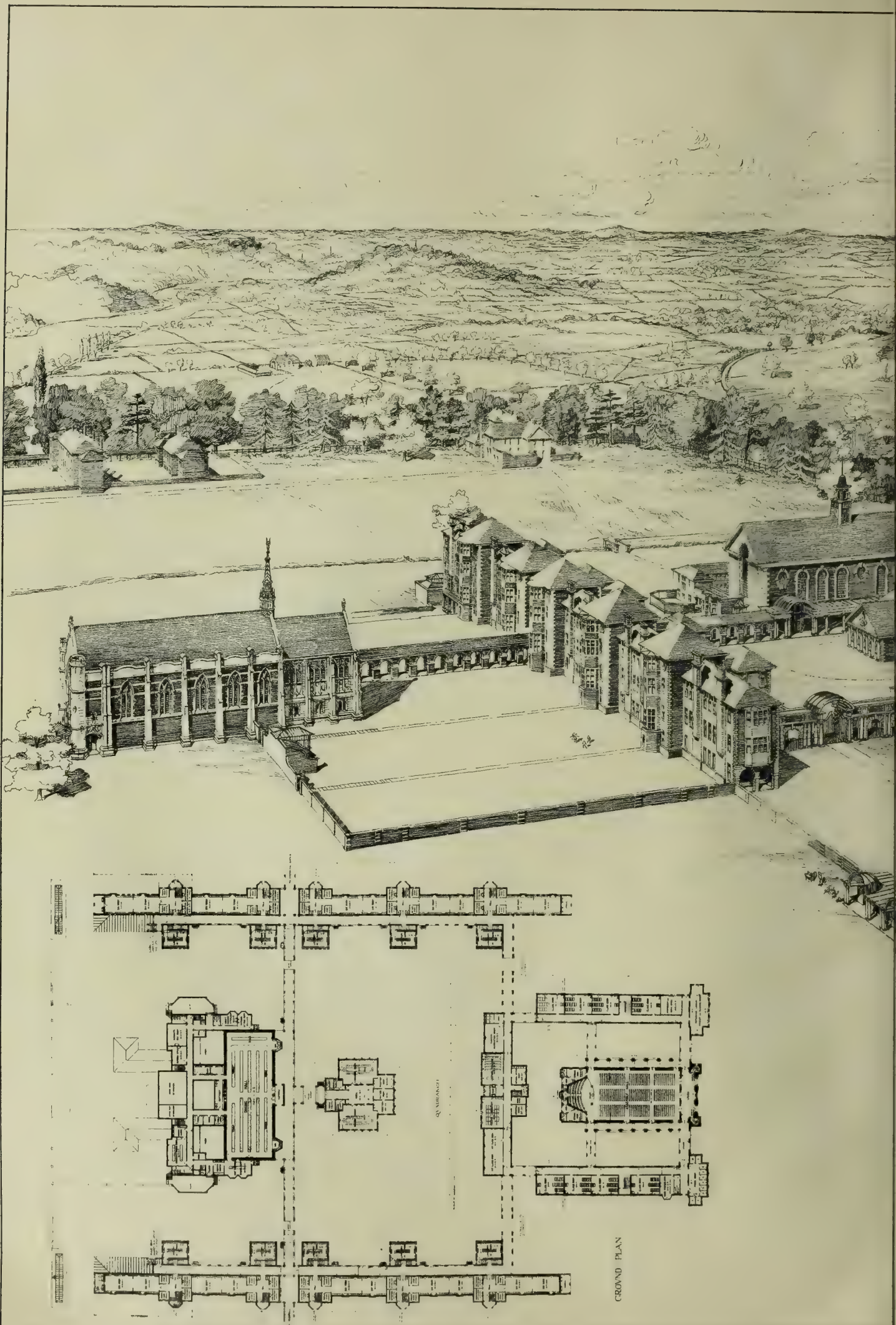



S. MAY. 13, 1898.



ROYAL MASONIC SCHOOL FOR BOYS AT BVSHEY : HERTS :

VIEW FROM SOUTH~WEST :

DESIGN PLACED THIRD

J. MORLEY

W. J. TAPPER

} JOINT ARCHITECTS.



1911

GLASGOW CATHEDRAL.

DRAWINGS BY HERBERT RAILTON & D. SMALL.



D Small

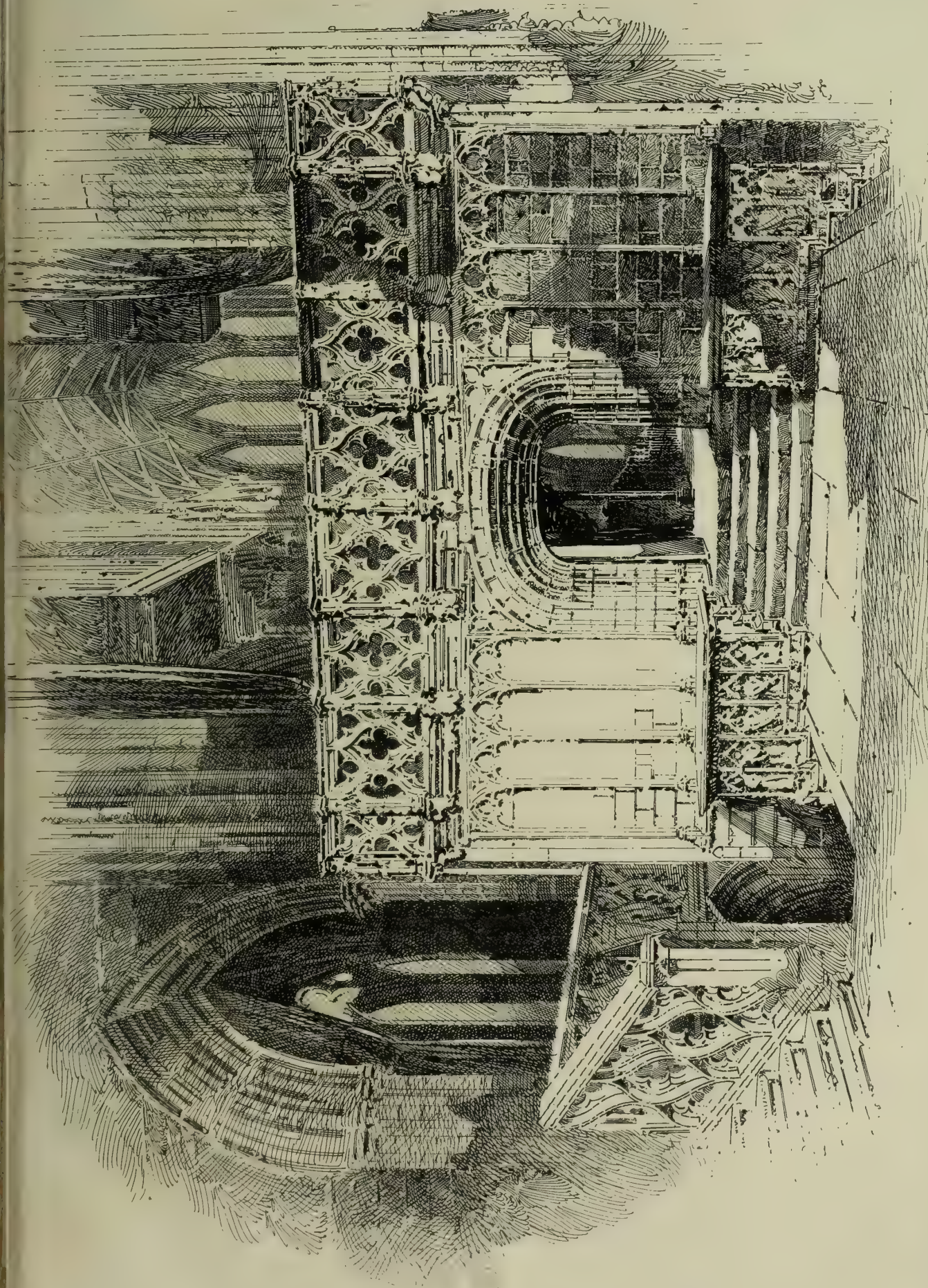

From "The Book of Glasgow Cathedral."

Roof Truss



### PROFESSIONAL AND TRADE SOCIETIES.

**THE ARTISTS' BENEVOLENT INSTITUTION.**—At the Hôtel Metropole on Saturday evening Sir H. Campbell-Banner, M.P., took the chair at the 83rd anniversary dinner in aid of the funds of the Artists' General Benevolent Institution. The list of guests included Sir Wyke Bayliss, Sir J. Tenniel, Mr. Alma Tadema, R.A., Mr. H. W. B. Davis, R.A., Mr. A. Waterhouse, R.A., Mr. Val Prinsep, R.A., Mr. E. A. Waterlow, A.R.A., Mr. W. W. Outess, R.A., and Mr. Douglas Gordon (secretary). The chairman proposed the toast of the evening, that of "Prosperity to the Artists' General Benevolent Institution." He observed that since it was founded the institution had expended in relief no less a sum than £122,398. Last year £4,095 were distributed in sums varying from £10 to £100 among 234 applicants. Those applicants were all of them artists, not necessarily subscribers to the association. The only claims recognised were those of merit on the one hand and distress on the other. The dignity and self-respect of the recipients of this most proper charity were secured by the fact that their names were not divulged. This immense boon was conferred on the artistic community at a cost for working expenses for the year of only £356. Artists were peculiarly liable to the vicissitudes of life, and it was to meet those vicissitudes that this most beneficent institution has been created. Mr. F. Harrison proposed "The Royal Academy and the Other Societies Connected with the Fine Arts," Mr. H. W. B. Davis and Mr. E. A. Waterlow responding. Mr. Alma Tadema proposed "The Visitors," Mr. Comyns Carr replying, after which Mr. Alfred Waterhouse, R.A., the treasurer, announced a list of subscriptions and donations amounting to nearly £2,000.

**BRISTOL SOCIETY OF ARCHITECTS.**—The last ordinary meeting of the society for the present session was held at the Fine Arts Academy, Clifton, on Monday, the 9th inst., when a thoroughly practical paper on "Plumbing," by Mr. Geo. Tuckey, was, in his unavoidable absence, read by the President. The "Conditions of Competition and Instructions to Students for Prize Drawings" were read, and it was decided to print same for circulation, together with a letter received from the principal of the Merchant Venturers' Technical College, stating that it was proposed to hold a special course of lectures for students desirous of presenting themselves for the Intermediate Examination of the R.I.B.A. It was decided to requisition a special meeting of the council, to consider the question of revising the society's by laws, so as to provide for the annual election of two Associates on the council.

**CREWE AND DISTRICT MASTER BUILDERS' ASSOCIATION.**—The first dinner of this association was held at the Hop Pole Inn, Crewe, on Tuesday in last week, when about forty builders and others sat down, Mr. J. Bebbington, the president, in the chair. Those present included representatives from the Potteries, Middlewich, Northwich, &c. The hon. sec., Mr. E. J. Smith, gave an encouraging report of the progress of the association since its commencement some six months ago, the membership having shown a steady increase. Mr. Smith also spoke of the better feeling created in the building trade throughout the district. Mr. F. Wooldridge proposed "The Town and Trade of Crewe, coupled with the Builders' Association." Mr. G. E. Morgan supported the toast, to which the treasurer (Mr. Micklewright), and Mr. Griffiths responded. Councillor Jones proposed the health of "The Visitors." Mr. J. Atkinson, architect, and Messrs. Longden, Grant, and Cooke responded.

**DEVON AND EXETER ARCHITECTURAL SOCIETY.**—The annual meeting of this society was held on Saturday at Exeter, under the presidency of Mr. James Hine, F.R.I.B.A., of Plymouth. The annual report was presented by the hon. secretary, Mr. Harbottle Reed. Among other matters it referred to the resolution which had been forwarded to the Exeter City Council with regard to the preservation of the Guildhall, and on receipt of which the corporation had the building examined and reported upon; also to the formation of students' classes, and the forthcoming exhibition of the Institute prize drawings in the Albert Memorial Museum on the 23rd inst. It was stated that the offer of a prize for the best sheet of prepared drawings had this year met with no response. A satisfactory balance-sheet

was submitted by Mr. Octavius Ralling, the hon. treasurer, after which the retiring president addressed the meeting. In the course of his remarks he said:—I shall be succeeded by a citizen of your "Ever Faithful" city who will carry out the duties of the chair more constantly and efficiently than I have been able to do. His early work gives me the keynote, then, of the few observations I have to offer. There is no more valuable part of a student's training than the study of good examples of ancient buildings, and the sketching, and, more particularly, the making exact measured drawings of such buildings. The idea of some may be that this tends to make a man a plagiarist; but experience shows that this kind of work gives him a mastery of his art, and a degree of freedom in designing which he would not otherwise possess. The period of pupilage is obviously the time and opportunity for cultivating the artistic side of an architect's work, because—as we have each of us found out—in the actual carrying out of an architect's business he has often to face very practical duties to the exclusion altogether of æsthetic considerations. Loyal, however, to his profession of a noble art, his principal aim will ever be to represent it adequately. It is much to the honour of Mr. Crocker that at the commencement of his professional career he distinguished himself by securing an Institute silver medal for his most admirable set of drawings and details of Exeter Guildhall, and to our hon. secretary (Mr. Harbottle Reed), who was quite recently awarded the Grissell gold medal for his clever design for a wooden church. There is no work so open to criticism—not even parsons' sermons—as the work of architects. Public and private, free and open, candid and spiteful, it lasts for all time, or as long as a building stands, and happy is the architect who is not very thin-skinned. There are two beautiful and picturesque towns in the West of England—Exeter, which was largely the creation of the 16th and 17th centuries, and Bath, which retains the beauty given it by Wood in the last century. Why is it that in the more modern towns, fashionable and unfashionable, which have sprung up during the present century the impress of architecture is so imperfect and unsatisfactory? Because for the most part they have not been the creations or work of architects. This has been a misfortune for our profession; but it has been a greater misfortune for the towns, and has been the occasion of numberless blots on the face of Nature. A vote of thanks to the retiring president was moved by Mr. Crocker. This was seconded by Mr. Arnold Thorne, Barnstaple, and supported by Mr. B. P. Shires, Plymouth, and Mr. James Jerman, Exeter. The following gentlemen were then elected for the ensuing year: President, Mr. James Crocker, F.R.I.B.A.; vice-president, Mr. H. G. Luff, A.R.I.B.A., Devonport; new members of council, Mr. James Jerman, F.R.I.B.A., Mr. S. Dobell, M.S.A., and Mr. B. P. Shires, A.R.I.B.A. The hon. treasurer (Mr. O. Ralling, M.S.A.) and the hon. secretary (Mr. Harbottle Reed, M.S.A.) were re-elected. Votes of thanks were accorded the retiring members of the council (Messrs. C. Cole and E. G. Warren) and the hon. secretary and hon. treasurer. A luncheon was afterwards held at the New London Hotel.

**EDINBURGH ARCHITECTURAL ASSOCIATION.**—The annual meeting of this association was held on the 4th inst. in the Royal Institution, Princes-street, Edinburgh, Mr. Thomas Ross, the president, in the chair. The report of the treasurer showed that the total membership of the association stood at 286, that the total income for the year amounted to £135 10s., and the payments to £134 4s. 11d. The secretary stated that in connection with the memorial which they had presented to General Sir R. Murdoch Smith, suggesting that the Museum of Science and Art might remain open between four and six o'clock on Saturday afternoons—which two hours would be very useful to architects, artists, and others for sketching purposes—he had received a communication from Sir Murdoch Smith to the effect that he had submitted the memorial to the Lords Committee of Council on Education, with a recommendation that the request therein set forth be acceded to. The president intimated that the Hon. Hew Dalrymple, on behalf of the Ayr and Galloway Archaeological Association, had presented the association with a set of their *Proceedings*, amounting to fourteen volumes—a valuable gift. Mr. Ross was re-elected president; Messrs. John Watson and James Bruce,

were re-elected vice-presidents; and Messrs. T. Fairbairn, A. Hunter Crawford, and J. Johnston, C.A., were re-elected secretary, excursion secretary, and treasurer respectively. The president afterwards delivered his valedictory address, the subject of which was "Lesser Known Churches of Scotland." Mr. Ross, whose address was illustrated by many beautiful limelight views, began with the earlier Norman churches, such as Leuchars, Dalmeny, and Tynninghame; next he directed attention to the elaborate church towers at Dunning, Muthill, and elsewhere in the district of the Tay; and dealing lastly with later churches, Mr. Ross gave a full exposition of the collegiate churches, of which he said there were somewhere between thirty and forty in Scotland, and which were all in the Late Scottish Gothic style, and were, perhaps, the most national works they had, without any affinity whatever to English work. The association visited on Saturday afternoon the mansion-house of Craigie Hall, under the leadership of Mr. John Watson, architect. The party proceeded up the Almond to the "Temple," a circular belvedere, of which the upper story is now a museum, containing antique busts, figures, &c., brought from Italy. The unique bath-house in the grounds, erected in 1747, was next visited. The bath in the basement was supplied from the Almond, and the dressing-room on the ground floor is profusely decorated with ornaments of shells arranged in architectural forms. At the mansion-house Mr. Watson described the building as a most interesting and fine example of the architecture of the end of the 17th century.

**EDINBURGH ARCHITECTURAL SOCIETY.**—At a meeting of the above Society, held on Wednesday in last week in Dowell's Rooms—Mr. William N. Cumming, A.R.I.B.A., in the chair—a lecture was delivered by Mr. A. N. Paterson, M.A., A.R.I.B.A., entitled "Evolution of the House: the Modern Product." Mr. Paterson arranged his lecture under three heads—(1) The modern house; (2) the country house; (3) the town house. Particular attention was given to aspect versus prospect in the planning of the mansion, the smaller country house or villa, and the cottage. In dealing with the town house, the limitation of light, air, and area were gone into, and in overcoming these the American style of planning was referred to.

**GLASGOW ARCHITECTURAL ASSOCIATION.**—The usual monthly meeting was held in the rooms, 187, Pitt-street, on Tuesday, the president (Mr. W. T. Conner) in the chair, when Mr. Oscar Paterson, Glasgow Art Workers' Guild, and lecturer on Technology of Glass, City and Guilds of London Institute, &c., read a paper entitled "About Stained Glass." Treating the art side of the question, he summed up the salient points thus:—"Circumstance of material governed the art of stained glass in its first stages of development. As 'art' progressed with a greater force than 'industry,' stained glass was more or less trammelled by difficulties of material; but when a certain progress and facility was attained, each craftsman followed out his art on the lines of his taste, temperament, or circumstance. Every stage of industrial progress is indicated in the development of stained glass, the most marvellous being in the present century." The practical side in the design he explained on slides illustrating old and modern work. At the close a hearty vote of thanks was passed.

**SANITARY INSPECTORS' ASSOCIATION.**—At a general meeting of the members of this association, held on Saturday evening at Carpenters' Hall, London Wall, E.C., Mr. T. G. Dee in the chair, Mr. W. Wilkinson read a paper on "Dangers to Health arising from Defective Sanitation." He observed that defective sanitation, as represented by badly designed structures, inefficient workmanship, and defective materials, produced, amongst other evils detrimental to health, typhoid and enteric and continued fevers, with diphtheria. The habits of the people with respect to cleanliness, and more especially with respect to their care to protect their habitations from pollution by excrementitious matter, were a clear indication of their progress in civilisation. It was a deplorable proof of the want of information and of due appreciation of the circumstances on which the improvement of the moral as well as the physical condition of the population depended that the existence of filth in houses and towns, the prevalence of filthy habits among the people, and the efforts to remedy or mitigate the attendant evils were often treated with the

greatest contempt, as if the subject were of no consequence, or fitted only to excite disgust. It might not be needful that persons on whom no duties in that direction devolved should enter closely into the details in question; but it was incumbent upon the local administration of the law for improving the sanitary condition of the people to show by their manner of dealing with its provisions that they regarded them as the practical fulfilment of the primitive ordinances for personal and household purification. It was important that they should treat even the minutest and most repulsive details with the same scrupulous and anxious care that physicians dealt with the most offensive particulars attending upon sickness, suffering, and mortal disease. In conclusion, the lecturer expressed the hope that, with reference to the Local Government Board inquiries in all matters relative to sanitation (whether of sewers, scavenging, or outfall works), the time was not far distant when that board would recognise the work of the Sanitary Inspectors' Association by electing from its ranks a representative to conduct or assist in conducting these inquiries.

#### CHIPS.

Mr. C. Hodgson Fowler, F.S.A., of Durham, has been appointed architect to the cathedral of Rochester, in succession to the late Mr. J. L. Pearson, R.A. Among his other appointments Mr. Fowler has been architect to the diocese of York for some time.

A fire which did damage to the extent of some £25,000 occurred at Edinburgh on Wednesday night, in the large horticultural buildings, manufactory, and engineering works of Messrs. Mackenzie and Mocur.

The Governors of St. Bartholomew's Hospital are in negotiation with the Council of Almoners of Christ's Hospital, with a view to acquiring a quarter of the total area of five and a-quarter acres, and it is probable that the remainder will be purchased by a railway company for the purpose of a City terminus.

Lord Masham has offered to place at the disposal of the Mayor of Bradford a sum of from thirty to forty thousand pounds for the purpose of erecting an institute on the site of his old home in Manningham Park, Bradford, which is now public property. He has also suggested that an attempt should be made to get a national memorial to Dr. Cartwright, the inventor of the power loom, and expressed his willingness to assist in that project. A committee has been formed to deal with the suggestions.

Cardinal Vaughan will lay the foundation-stone of the new Roman Catholic church at Ilford, tomorrow (Saturday), at four p.m.

The County Council for East Sussex, at their meeting on Tuesday, received the resignation of Mr. H. Card, of Lewes. In accepting the resignation, reference was made to the efficient services Mr. Card has rendered the council for nearly half a century, and it was decided to appoint him as consulting engineer at a salary of £200 a year. Notice was given of a resolution to be passed at the next meeting expressive of the council's appreciation of Mr. Card's valuable services.

Alterations are being made to Wallingford boys' school, embracing the ventilation, which will now be carried out on the Boyle system.

Mr. E. A. M. Sandford Fawcett, A.M.I.C.E., inspector of the Local Government Board, attended at the Moot Hall, Aldeburgh, on Thursday last week, to hold an inquiry in reference to an application by the town council of that borough for the sanction of the Board to a loan of £11,000 for the purposes of sewerage and sewage disposal.

The health committee of the Liverpool Corporation recommend that Mr. James Morgan, chief surveyor of roads, whose present salary is £400 per annum, be appointed deputy city engineer, at a salary of £500 per annum.

On Saturday an inquest was held at Horseley relative to the death of Edward Avery (47), foreman at Horseley Works, where he received fatal injuries on the previous Thursday. Alfred Purnell, an employé, stated that on Thursday deceased was engaged superintending the lowering of the principal of a roof in course of construction. A girder was being lowered by a derrick, when the back guide-rope broke, throwing the weight on the other two ropes. This caused the girder to swerve, and one end of it struck deceased in the back. The rope, which was about 1 in. thick, had been in use about a month. James Dunn, works manager, said deceased had been a foreman for six or seven years. Ropes were used as guides for derrick purposes, but chains were always employed for lifting. The jury, in returning a verdict of "Accidental death," recommended that some method of testing derrick-ropes be adopted in future.

## Our Office Table.

WE understand that the choice of names made by the council of the Royal Institute of British Architects, under the chairmanship of Professor Aitchison, has been submitted to the Minister of Public Works, and the following gentlemen, if the Government approves of the selection thus arrived at, will, it is said, be invited to design the elevations for the new War Office in Parliament-street. It is to be noted, if this is the case, that out of the eight architects thought worthy of the honour two only are Englishmen, three are Scotch, and three are Irishmen. We give them in this order of nationality—viz., Messrs. John Belcher and Charles Barry, Messrs. J. M. Brydon, Wm. Young, and John Burnet; Messrs. Thomas Drew, R.H.A., and W. H. Lynn, R.H.A., and Sir T. N. Deane, R.H.A. The two last named are the only two proposed competitors who are not Fellows of the Royal Institute. It was understood that the selection would be made mainly on consideration of the successful buildings actually erected by the competitors in a *Classic style* of architecture. We make no further comment.

MR. C. B. BRODIE, A.R.I.B.A., has addressed a moderately-worded open letter to the council and members of the Institute of Architects, suggesting the desirability of a limitation of the term of office for members of council of that body. He says there seems some justification for the assertion that the council has become a sort of close corporation, the members of which nominate each other constantly. Taking the nomination list just issued by the council, Mr. Brodie finds that 25 out of the 38 members of the council nominated are "starred" as being members of that body. This would show 26, because Mr. Hampden W. Pratt is now a member, whilst Mr. E. T. Hall, Mr. Beresford Pite, Mr. J. S. Gibson, and Mr. Leonard Stokes have all previously served, so that brings the total to 30 old members of council nominated out of 38 names on the list of ordinary members. One main reason Mr. Brodie thinks why the London Architectural Association is becoming proverbial for its rejuvenescence, while it stands pre-eminent for life, energy, and progress in the profession, is because the bylaws allow only a certain number of the old committee to be re-elected each year, and provide that no member may sit on the committee as an ordinary member for more than three successive sessions. This would probably be too short a term for the Institute, but he urges that some limit should be put. Referring again to the nomination list just issued, among those nominated, one has been a member of council for 14 consecutive sessions, another for 13, two for 12, two for 11, two for 10, two for 9, two for 8, and one for 7—all consecutive sessions. One member, now renominated for a seat on the council, was on it as long ago as 1881. Mr. Brodie pertinently suggests that now that the bylaws are being amended, the opportunity should be seized to insert a limitation of term of office.

The great revival of appreciation of the works of the 18th-century painters, and which has been recently evidenced by the very high prices paid in the auction rooms, even for their engravings, makes the exhibition which the Fine Art Society will open on the 16th inst. in New Bond-street of exceptional interest, for it will include not only a large number of the miniatures but nearly 50 of the full-length drawings of Cosway, some forty of Downman's fascinating profiles of 18th-century beauties, and some of the finest extant specimens of Plimer, Smart, Engleheart, and the pick of the miniaturists of that time. The collection, which includes some 300 numbers, has been many years in formation, and has been made by an expert having exceptional opportunities of acquiring undoubted specimens. The introduction to the catalogue will be written by Dr. Lumsden Propert.

"THE LIFE WORK OF MR. WILLIAM MORRIS" was the subject of an address delivered on Tuesday afternoon before the Applied Art Section of the Society of Arts, Dr. Richard Garnett, C.B., presiding, by Mr. F. S. Ellis. The lecturer described Morris's career as not only wonderful but unique. While possessed of a versatile genius, William Morris was one of the most humble-minded of men. It spoke volumes for his vigour and hopefulness that he ventured to set forth, so to speak single-handed, on the task of awakening people to a

sense of the hideousness that surrounded them and the possibility of something more artistic and beautiful. But for the life work of Morris the amelioration of commonplace ugliness, which might be traced in thousands of houses, would never have come about. In regard to his connection with the Socialist movement, once convinced of the justice of the cause, he cast aside all considerations of personal taste, ease, and comfort, doing violence to his own feelings and predilections, and forcing himself to personal work and labour that were absolutely distasteful to him. Never did any man give himself to a cause with purer unselfishness and more hearty devotion. In his later years, though he did not alter his opinions, it appeared that he was satisfied that any chance of forcing on a sudden change was altogether hopeless.

MR. E. M. BELOE, JUN., of King's Lynn, Norfolk, whose rubbings of Norfolk brasses we noticed in these pages some seven years since, has now published a set of eight plates in illustration of the monumental brasses in Westminster Abbey, small folio size. The frontispiece is a well-executed chromo-lithograph of a fragment of a tomb, probably erected to a son of William de Valence, showing eight Lombardic letters in brass and original mosaics in red, white, and gold. The four letters R L E A are suggested as a portion of the surname "Varleance." The plate has been produced from a water-colour by Miss E. M. Vincent. Sir Gilbert Scott uncovered the slab of this monument from under a step in the Confessor's Chapel. The brasses given by Mr. Beloe are of John de Waltham, Bishop of Salisbury, Lord High Treasurer, 1395; Robert de Waldeby, Archbishop of York, 1397; Alianore de Bohun, widow of Thomas Woodstock, son of Edward III., 1397; Sir John Harpedon, 1437; Abbot John Estney, 1498; Sir Humfrey Stanley, body-guard to King Henry VII., 1505; fragments of brasses to Sir Thomas Vaughan, 1483, and Sir Humfrey Bourghier, who was killed at the battle of Barnet, 1471. The last plate also gives three examples. The only rubbing on this sheet is of William Bill, Chief Almoner to Queen Elizabeth, and Dean of Westminster, 1561. The other illustrations are of the slab still in the Chapel of St. Andrew to Edmund Kirton Abbot, 1466, from Gough's "Sepulchral Monuments in Great Britain," and of the slab to Thomas Woodstock, before mentioned, who died in 1397. The monument is to be seen in the Confessor's Chapel. From this index list it will be seen that Mr. Beloe has added some very remarkable historic examples to the published rubbings of old English brasses, which never fail to interest a large number of readers who are glad to increase their acquaintance with the archaeology of the subject and add to their knowledge of Mediæval costume and monuments of distinguished personages.

THE annual meeting of the members of the District Council for Edinburgh and the East of Scotland of the National Registration of Plumbers was held on Friday night in Dowell's Rooms, Edinburgh, Sir James Russell presiding. The report, which was read by Mr. James Marchbank, the secretary, stated that there was a larger membership than the previous year, while the financial statement showed that the year began with a debit balance of £35, and ended with a favourable balance of £18 9s. With regard to the Plumbers' Registration Bill, the measure had been amended considerably, and every effort would be made to have it passed through Parliament. The chairman said the Plumbers' Registration Bill, as they had heard, was very greatly improved, but the prospects of a private Bill this session were extremely bad. Every year that the measure had been shown to the House it had been a better Bill. It was, however, an unfortunate thing for the public health, not to speak of the plumbing craft, that its passage through Parliament was so difficult. Nothing but the general education of the public had ever led to the passing of any Bill relating to public health. The report was adopted. Sir Douglas MacLagan was re-elected honorary president, and Sir James Russell president.

THE excessive draught in the Bristol Council Chamber has led to inquiries, which have resulted, according to the *Bristol Mercury*, in the explanation that the special electrical ventilation apparatus provided on the plan of Professor Wertheimer has never had a real chance of justice being done to it. This arises from the fact that it is so scientifically arranged and



adjusted for precise conditions that the moment these conditions are broken the delicate arrangement of the apparatus is dislocated, and its effect entirely lost. It is stated that it was designed for a room with closed doors, and the ordinary ventilators in the walls of the hall, intended to admit fresh air, should be left open. But the practice is for all these ventilators to be closed, as the room is felt to be too cold, and then only too often the doors at the extreme end are thrown open. Immediately these conditions prevail, the whole effect of the electric ventilator is subverted, with the result that an insufferable draught is generated. This, it is contended, is entirely brought about by upsetting all the scientific conditions to which the new ventilator of Professor Wertheimer will alone apply.

MESSRS. WM. R. NICHOLAS AND CO., of 60, Pall Mall, S.W., advertise in our columns that they will sell by auction, in lots, on June 7 a valuable building estate at Newmarket on a new and easy way as regards payment. Instead of paying the whole of his purchase money at once, Messrs. W. R. Nicholas and Co. have arranged that the purchaser may extend it over a term of 10 years, by instalments. The land appears to be anything but a "white elephant." On the contrary, it is situated adjoining the Great Eastern Railway station at Newmarket, and is stated to be the most valuable for building purposes ever likely to come into the market in the Metropolis of the Turf.

### CHIPS.

The electricity committee of Glasgow Town Council have approved generally of the report by Mr. W. A. Chamen, epitomised by us last week p. 657, for the supply of electricity within the municipal area. The expenditure involved is half a million.

The Lynton and Barnstaple Railway was opened on Wednesday. The line is 19½ miles long, and is connected with the London and South-Western system.

There was a diminution of supply at the Auction Mart last week. The aggregate realisation was £119,107, considerably less than that registered in the corresponding week of last year—£142,874. The demand, however, was quite up to the average, and few good investments were passed by. Landed estate is still conspicuously absent from the market, but there are indications of improved business in this direction after Whitsuntide.

An application having been made by the Little Crosby Urban District Council to the Local Government Board for powers to borrow a sum of £3,000 for purposes of street improvements, an inquiry conducted by Mr. Tulloch, M.I.C.E., was held on Friday, at Little Crosby Hall. Mr. Thomas Dixon, surveyor to the urban district council, explained the proposals.

On Thursday in last week, Col. A. J. Hepper, D.S.O., R.E., an inspector of the Local Government Board, held an inquiry at the town-hall, Tunstall, in reference to an application by the urban district council for sanction to borrow £850 for the purchase of land for the purposes of street improvements. Particulars of the scheme were supplied the inspector by Mr. A. P. Llewellyn (clerk) and Mr. A. R. Wood (surveyor), showing that it was proposed to acquire part of the site of the Globe Pottery, at the corner of High-street and Amicable-street, and to carry out a widening of these thoroughfares.

The death is announced of Mr. John Mackay, railway contractor, at the residence of his son-in-law, Nether Wellwood, Muirkirk. Mr. Mackay was the oldest Scottish railway contractor, and was present at the cutting of the first turf on the old Edinburgh and Glasgow railway. His largest contracts were for the making of the Highland line from Dunkeld to Kingussie, Callander and Oban, and Stobcross and Wishaw Central.

Lord Ashcombe, on Saturday, laid the foundation-stone of a new church on Cranleigh Common, near Guildford, which is being erected in commemoration of the 60 years' reign of her Majesty.

The joint committee of the East and West Riding County Councils of Yorkshire have taken Manor Farm, Garforth, near Leeds, on a term of years for the purpose of technical instruction in farming. Plans are now being prepared by Mr. Joseph Shepherdson, architect, Driffeld and Hull, for a new set of buildings, which are to be erected forthwith.

Mr. William Lindley Catlin, late clerk of works of the Haverhill (Suffolk) Waterworks, has been appointed engineer and manager of the Faversham Water Company, Ltd., in place of Mr. Robert Darney (resigned), who has held the post since 1863.

### MEETINGS FOR THE ENSUING WEEK.

SATURDAY (TO-MORROW).—St. Paul's Ecclesiastical Society. Visit to churches of Perivale and Greenford, under guidance of H. Roumieu Gough, F.R.I.B.A. Book by District Railway Company train due at Ealing at 3.30 p.m.

MONDAY.—Society of Arts. "Electric Traction," Cantor Lecture No. 3, by Professor C. E. Carus Wilson, of McGill University, Montreal. 8 p.m.

Royal Institute of British Architects. "The Libraries of the Middle Ages," by T. G. Jackson, R.A. 8 p.m.

Surveyors' Institute. "Comparative Values of Cattle Foods: Chemist versus Valuer," by H. T. Eve. 8 p.m.

TUESDAY.—British Association of Waterworks Engineers. Annual Five Days' Meeting at Southampton. Proceedings to be opened 10.30 a.m.

WEDNESDAY.—Society of Arts. "The Evolution of the Cycle," by J. K. Starley. 8 p.m.

British Association of Waterworks Engineers. Meeting at Southampton. Papers and Discussions, 10 a.m. Annual Dinner, 7.30 p.m., at Dolphin Hotel.

The Edinburgh Architectural Society. "Church Decoration in Norfolk," by Alfred Greig. 8 p.m.

THURSDAY.—Home Arts and Industries Association. Fourteenth Annual Exhibition at Royal Albert Hall. 2.30 p.m.

Society of Arts. "Chartered Companies and Colonisation," by Sir Alfred C. Lyall, S.C.I.E., K.C.B. 4.30 p.m.

British Association of Waterworks Engineers. Meeting at Southampton. Papers and Discussions. 10 a.m.

FRIDAY.—Architectural Association. "Foundations for London Buildings and Riverside Foundations," by A. S. Walmisley. 7.30 p.m.

British Association of Waterworks Engineers. Leave Docks Railway Station, 9 a.m., for Fareham, to visit the Gosport and Portsmouth Water Supply Works.

### THE ARCHITECTURAL ASSOCIATION.

MAY 20th, ORDINARY MEETING, 9, Conduit-street, W. 7.30 p.m. Mr. A. T. WALMSLEY, on "FOUNDATIONS AS APPLIED TO LONDON BUILDINGS, AND RIVERSIDE FOUNDATIONS."

Election of Officers for Session 1898-99. MAY 21st, SPRING VISIT to Grote Hospital, Tooting, Mr. A. H. Tiltman, Architect. Meet at 3.30 p.m. Trains leave Ludgate Hill for Tooting Junction at 2.51.

E. HOWLEY SIM } Hon. Secs.  
G. B. CARVILL }

## Trade News.

### WAGES MOVEMENTS.

ARBITRATION IN THE NORTH STAFFORDSHIRE BUILDING TRADE.—The members of the Potteries, Newcastle, and Leek branch of the Operative Bricklayers' Association having made a demand for an increase of a penny upon the present rate of 8½d. per hour, and the Master Builders' Association having refused to accede to such demand, the dispute has been referred to Mr. Talbot Baines, an arbitrator of the Board of Trade. The case for the applicants is that they considered the advance of a farthing per hour granted by Sir W. Markby in 1896 hardly enough under the circumstances, and, having submitted to that decision for two years, they thought that they were justified, in the present state of the building trade, in again asking for a revision of the scale. The case for the builders is that there has been no such change in the trade as to justify the demand made by the bricklayers, and that such demand has been made because the bricklayers thought it was possible that they themselves would receive a notice for reduction of wages from the employers. The stonemasons and bricklayers' labourers had also asked for an increase of 1d. an hour, but the former had accepted ½d., making their wages equal to those of the joiners and bricklayers, and the latter had withdrawn their notices. At an inquiry into the dispute, held at Stoke-on-Trent, the arbitrator endeavoured to effect an amicable settlement, but failed. He said he would give the subject his full consideration and forward his decision in due course.

BANGOR.—The joiners who, a fortnight ago, went on strike for an increase of wages, resumed work on Tuesday, the employers acceding to the demand of 6½d. per hour. The building trade in the district is very brisk.

BURTON-ON-TRENT.—It was officially stated on Friday that the strike of painters had terminated. The men, who have been out since the 1st of April, asked for an increase of ½d. per hour, their present rate of payment being 7d., and a revision of the rate as to out-of-town work. A compromise was effected on Friday, by which the men agree to accept an increase of ½d. per hour, while expenses are to be allowed for Sunday when the men are engaged away from the town. Both sides express much gratification at the issue.

CATERHAM.—The trouble in the building trade was

settled on Friday, the master builders conceding a halfpenny per hour advance, with a code of working rules to carpenters and bricklayers from May 2.

FAREHAM.—The threatened trouble in the building trade has been averted, except in the case of labourers. The men, at a meeting of the general trades, asked for an increase of 1d. per hour, and to cease work at 1 p.m. on Saturdays instead of at four. In the case of the bricklayers, carpenters, and painters, the demands have been conceded; but in the case of the labourers the request has not been complied with in some cases, so that the men went on strike.

HARTLEPOOL.—The house joiners in the employ of Mr. John Burn, one of the largest builders in the Hartlepoles using Canadian-made doors and window frames, are on strike. The Employers' Association have the strike under consideration, and threaten to lock-out the whole of the workmen if those on strike do not return to work. This the latter refuse to do, and it is feared a lock-out, which will extend over the whole of the North of England, will ensue.

LANCASTER.—About 270 stonemasons have ceased work at Lancaster because the masters desire to amend the rules, according to notice, which will reduce the working hours half an hour per morning in the first week of February. The men got an advance of ½d. per hour last year, making their wages 9d. per hour, and the masters say that they cannot see to work before 7.30 until the second week in February. The employers are nearly all connected with the recently formed Building Trades' Federation of Lancashire and Cheshire.

ST. ALBANS.—The carpenters of this city have made a demand for an increase of 1d. per hour in wages.

TEIGNMOUTH.—One firm of builders have decided to give their men an extra ½d. per hour without any application from the men. It is expected that other employers will do the same.

WEST BROMWICH.—About 150 youths and girls in the employ of Messrs. Hamblett came out on Monday for an increase in their wages. Other brick manufacturers in the West Bromwich district have received the usual seven days' notice from the youths and girls in their employ to terminate their engagements unless their demands are conceded.

The reopening of the new wing to Salisbury School, erected at a cost of over £2,000, took place on Monday.

The foundation-stone of the new town-hall for Enniskillen was laid on Monday in last week. The building, which was illustrated by a double-page perspective and plans of two floors in our issue of Dec. 17, 1897, is being erected from designs by Messrs. A. Scott and Son, selected in competition. It will be faced with Carrick Creagh limestone, with designs of Dungannon sandstone. Mr. James Harvey, of Enniskillen, is the builder.

Operations have been started this week for the underpinning of the north-eastern corner of the Eastern Chapel of Peterborough Cathedral. Although the excavation has, up to the present time, not been carried to a very great depth, yet many pieces of tooled masonry belonging to the abbey have been found. Passing in a north-easterly direction at this point was the ancient dyke which bounded the Saxon church of the Peterborough of that day. It is believed that the subsidence of the corner of this chapel is partly due to the foundations having been placed in this ditch.

Mr. D. M. F. Gaskin, M.Inst.C.E., civil and consulting engineer, has been appointed as the consulting engineer to the Newton-in-Makerfield Urban District Council. Mr. Gaskin is an old Liverpool Corporation official, and served under Mr. Thomas Duncanson and Mr. G. F. Deacon.

A loan of £5,130 has been granted to the Greenwich District Board of Works by the London County Council for the purchase of a site for a parish yard in Blackwall-lane.

## PILKINGTON & CO.

(ESTABLISHED 1838),

MONUMENT CHAMBERS,  
KING WILLIAM STREET, LONDON, E.C.

Registered Trade Mark:

## POLONCEAU ASPHALTE

Patent Asphalt and Felt Roofing.

ACID-RESISTING ASPHALTE.

WHITE SILICA PAVING.

SEYSSSEL ASPHALTE.

LIST OF COMPETITIONS OPEN.

Wrexham—Proposed New Boys' and Girls' Schools at Grove Park (cost about £8,000).....	£50 (merged), £20	W. R. Evans, 56A, Hope-street, Wrexham	May 18
Tipton—Laying Out Park (£4,000 limit).....	£25 (merged), £10	John W. Waring, Clerk, Public Offices, Tipton	" 25
Trowbridge—Technical School (£5,500 limit)—Mr. E. W. Mountford, F.R.I.B.A., Assessor).....	£40 (and 5 per cent. com.), £30, £20	H. Ledbury, Sec., Castle-street, Trowbridge, Wilts.	" 28
Cricklade—Water-Supply Schemes.....	£21, £10 10s.	Harry Bevin, Clerk R.D.C., Union Offices, Wootton Bassett	" 31
Wallsend—Laying-out Park.....	£50, £20	W. S. Daglish, Clerk, 28, Sandhill, Newcastle-on-Tyne	June 1
Pendlebury—Three Chapels, Offices, Lodge, Entrance Gates, and Boundary Walk, at proposed Cemetery.....	£50 (merged), £30, £20	Samuel Brown, Town Clerk, Town Hall, Salford	" 7
East Ham—Public Offices, Library & Technical Institute, Fire-Engine Station, Public Baths, and Offices (cost about £55,000).....	£105 (merged), £52 10s.	C. E. Wilson, Clerk U.D.C., Public Offices, East Ham, E.	" 24
Bridlington Quay—Orphanage and Convalescent Home, St. John's-avenue (cost about £1,500).....	£25, £10	George Abbott, Secretary, 222, Solly-street, Sheffield	" 30
Formby—Sewerage of a Portion of the Township.....	£100, £50, £25	J. H. Havelock Sutton, Surveyor, Piercefield-road, Formby	July 1
Warrington—Police Station, Court House, &c.....	£100, £50, £25	J. Lyon Whittle, Clerk, Town Hall, Warrington	" 2
Stockholm—City Railway Stations and Junctions.....	£656, £438, £219	Consulate General, 27, Great Winchester-street, E.C.	Aug. 31

LIST OF TENDERS OPEN.

BUILDINGS.

Pudsey—Twelve Terrace Houses at South Parade.....	Leeds Industrial Co-operative Socy.	Herbert Hodgson, A.R.I.B.A., Old Bank Chambers, Bradford	May 14
Willenhall—Infant School.....	Willenhall & Bentley School Board.	Joseph P. Baker, Architect, 33, Market-place, Willenhall	" 14
Paisley—Mossvale Public School (1,200 Scholars).....	School Board.....	Macrobert and Hutchison, Clerks to Board, County Buildings, Paisley	" 14
Turriff—Houses at Mosside, Cloddach, and Caslehill.....	Governors.....	James Duncan and Son, Architects, Turriff	" 14
Downpatrick—Additions at the County Infirmary.....	G. Kendrick and Son	The County Surveyor, Downpatrick	" 14
King's Lynn—Rebuilding Premises, High-street.....	W. R. Law, Surveyor, 3, Lord-street, Liverpool	William Jarvis, Architect, Market-square, Lynn	" 14
Hoylake—Station Buildings.....	J. Faulkner	W. M. Law, Surveyor, 3, Lord-street, Liverpool	" 14
Brotton—Two Houses.....	Commissioners of H.M. Works	Arthur F. Newsome, M.S.A., Architect, Middlesbrough	" 14
London, E.C.—Foundations for Third Section of Parcel Depot, Mount Pleasant.....	Vicar	Hon. Reginald B. Brett, Secretary, 12, Whitehall-place, S.W.	" 16
Accrington—St. Mary's Infant School.....	Alexander Roger, M.B.	Hy. Ross, Architect, 13, Cannon-street, Accrington	" 16
Yetholm—Residence, with Stabling.....	Weaver Navigation Trustees	Todd and Thorpe, C.E., County Bldgs., Land of Green Ginger, Hull	" 16
Great Hampton—Four Pairs of Cottages.....	Cumberland Asylum	Saml. Summers, Great Hampton, Evesham	" 16
Weston Point—Reconstruction of Spire of Christ Church.....	Leeds Laundry Co.	J. A. Saner, M.I.C.E., Engineer, Northwich	" 16
Garlands—House for Private Patients.....	J. Webster	Geo. Dale Oliver, County Architect, 5, Lowther-street, Carlisle	" 16
Leeds—Laundry Buildings & Carpet-Beating Works, Aire-pl. Aintree—Six Shops, Longmoor-lane.....	Corporation	Johnstone Bros., Architects, 39, Lowther-street, Carlisle	" 16
Castleford—Two Houses, Smawthorne-lane.....	F. W. Hartley, Aintree, Liverpool	W. P. Hartley, Aintree, Liverpool	" 16
Southampton—Municipal Lodging House.....	Corporation	Arthur Hartley, Architect, Carlton Chambers, Castleford	" 16
Fowey—Premises, Little Fore-street.....	Fowey Wine Company	G. B. Nalder, Town Clerk, Southampton	" 16
Wednesbury—Fire Station.....	Corporation	Graham and Graham, Solicitors, Fowey, Cornwall	" 16
Cork—Converting Stores into Stables, Lower George-street.....	Corporation	E. Martin Scott, Borough Engineer, Town Hall, Wednesbury	" 16
Tynemouth—Market Shed, Fish Quay.....	Town Council	James F. M'Mullen, M.S.A., Architect, 30, South Mall, Cork	" 16
Croydon—Store and Workshop Buildings, Factory-lane.....	Kay and Wilkinson	John F. Smilie, Borough Surveyor, Tynemouth	" 17
Bury—Works in Butcher-lane and Chapel-street.....	Great Western Railway Co.	E. Mawdesley, Town Clerk, Town Hall, Croydon	" 17
Cross Keys—Four Cottages.....	School Board	D. Hardman, Architect, Silver-street, Bury	" 17
Ipswich—Classroom, California School.....	Great Western Railway Co.	G. K. Mills, Secretary, Paddington Station, London	" 17
Castle Hill—Seven Coal Offices.....	Barton-upon-Irwell Guardians	J. Hepburn Hume, Clerk, Tower House, Tower-street, Ipswich	" 17
Highfield, Herts—Two Pairs Semi-detached Villas.....	William Mossop	G. K. Mills, Secretary, Paddington Station, London	" 17
Patricroft—Workhouse Infirmary.....	Corporation	F. G. Barnes, Glebe Cottages, Hatfield	" 18
Hatfield—Two Pairs of Semi-Detached Villas.....	Corporation	J. W. Whitworth, Clerk, Union Offices, Patricroft	" 18
Broughton Moor—Cottage.....	Guardians	F. G. Barnes, Glebe Cottages, Hatfield	" 18
Wakefield—Workshops and Office, King-street.....	Managers	Bowman Eilbeck, Broughton, Cumberland	" 18
Leeds—Two Villas at Gledhow Park.....	Celbridge Union Guardians	Richard Porter, City Surveyor, Town Hall, Wakefield	" 18
Oakham—Provender Stores.....	R. J. Atkinson	W. H. and A. Sugden, Architects, Keighley	" 19
Marsden—Five Shops and Houses, Ready Carr-lane.....	Burgh Commissioners	James Williams, Secretary, Derby	" 19
Bristol—Clerk's Offices, St. Peter's Hospital.....	Committee	John Kirk and Sons, Architect, Huddersfield	" 19
Lancaster—South Wing to Royal Albert Asylum.....	Newton-in-Makerfield U.D.C.	J. J. Simpson, Clerk, St. Peter's Hospital, Bristol	" 19
Banstead—Drill-Hall and Gymnasium at School.....	Rev. P. Grant, P.P.	Austin and Paley, Architects, Castle Hill, Lancaster	" 19
Rathoole—Repairs to Residence.....	School Board	Cecil Sharp, Architect, 59, Fenchurch-street, E.C.	" 20
Kinloss—Cottage.....	Bainbridge and Co.	J. McDonnell, Architect, 33, Kildare-street, Dublin	" 20
Berwick—Terrace of Houses.....	School Board	Charles C. Doig, Architect, Elgin	" 20
Annan—Slaughter-House.....	School Board	Parade View, Berwick	" 21
Kingswood—Two Shops, Moravian-road.....	Urban District Council	Murray Little, Clerk, Town Hall, Annan	" 21
Wakefield—Boiler-House and Engine-Room at Asylum.....	F. A. Cliff	Henry M. Bennett, Architect, 36, Corn-street, Bristol	" 21
Earlestown—Mortuary.....	Corporation	J. Vickers Edwards, County Surveyor, Wakefield	" 21
Money Meary, Draperstown—New Church.....	City of London Burial Board	W. W. Shirley, Clerk, Town Hall, Earlestown	" 21
Leeds—Shoe Factory in Kirkstall-road.....	Committee of Visitors	E. J. Toye, Architect, Londonderry	" 21
East Ham—Board Offices and Pupil Teachers' Centre.....	Guardians	Percy Robinson, Architect, 72, Albion-street, Leeds	" 23
Leeds—Five-Story Warehouse, Grace-street.....	School Board	W. J. Brett, Clerk, 1, Lichfield-terrace, Upton Park	" 23
Hastings—Additions, Silverhill School.....	Corporation	Thomas Winn, Architect, 92, Albion-street, Leeds	" 23
Leeds—Ten Small Houses, Derwent-avenue.....	Urban District Council	H. Tendall, Clerk, 4, Bank-buildings, Hastings	" 23
Wakefield—Sewage Well and Engine-House, Calder Vale.....	Corporation	City Engineer's Office, Municipal Buildings, Leeds	" 23
Uxbridge—Foreman's House at Sewage Works.....	City of London Burial Board	R. Porter, C.E., City Engineer, Town Hall, Wakefield	" 23
Leeds—Alteration of Blue Bell Hotel.....	Committee of Visitors	William L. Eves, Surveyor, 54, High-street, Uxbridge	" 23
Huddersfield—Brick Culvert (1,593 lin. yards).....	Guardians	Thomas Winn, Architect, 92, Albion-street, Leeds	" 23
Iford—Cemetery Works.....	School Board	Town Clerk, Town Hall, Huddersfield	" 24
Bandon—Additions to Presentation Convent.....	Corporation	H. Montague Bates, Clerk, Guildhall, E.C.	" 24
Humberstone—Superstructure of New Buildings at Asylum.....	Windy Nook Co-operative Society	M. A. Hennesy, Architect, 74, South Mall, Cork	" 24
Farnham—Infirmary at Workhouse.....	Government of Ecuador	George T. Hine, F.R.I.B.A., 35, Parliament-st., Westminster, S.W.	" 24
Huddersfield—Surgery in Brunswick-street.....	Municipal Authority	Ernest Crundwell, Clerk, South-street, Farnham	" 25
Ugborough—Enlargement of Infant School.....	Guardians	John Kirk and Sons, Architects, Huddersfield	" 25
Darwen—Electricity Supply Works and Refuse Destructor.....	School Board	Edward Wincat, Clerk, 19, High-street, Totnes	" 26
Felling—Twelve Cottages, Coldwell-lane.....	Corporation	Town Clerk, Darwen, Lancs.	" 26
Hawes—Residence.....	Windy Nook Co-operative Society	H. Miller, A.M.I.C.E., Wesley-terrace, Felling	" 27
Talkin—Reading-Room.....	Guardians	J. P. Kay, Architect, 31, Prudential-buildings, Leeds	" 27
Leeds—Seven Houses and Shops, Kirkstall-road, and Six Houses, Greenhow View.....	Benjamin Greaves	H. Scorer, Naworth Estate Office, Brampton	" 28
Warrington—Green-House at Cemetery.....	Cemetery Committee	Thomas Winn, Architect, 92, Albion-street, Leeds	" 30
Alverstone—Enlargement of Board-Room at Workhouse.....	Guardians	Thomas Longdin, Borough Surveyor, Town Hall, Warrington	" 31
Guayaquil—Custom House.....	Government of Ecuador	H. F. A. Smith, Architect, Star Chambers, Gosport	June 1
Belem—Cattle Pens, Abattoir, and Two Markets.....	Municipal Authority	Chief Ecuadorian Consulate, Liverpool	Aug. 31
Heywood—Tower at Phoenix Brewery, Green-lane.....	Municipal Authority	The Brazilian Legation, London	Oct. 24
Ilkeston—House and Offices, Lord Haddon-road.....	Thos. White	C. H. Openshaw, Architect, Derby Chambers, Fleet-st., Bury, Lancs.	"
Haverthwaite—Parish Hall.....	J. Barber, J. P.	W. Dymock Pratt, Architect, Cauldon-pl., Long-row, Nottingham	"
Harrogate—Stable.....	School Board	Settle and Farmer, Architects, Ulverston	"
Govilon—Additions to Dwelling House, Boathouse Farm.....	Grimshaw, Ltd., Keirby Brewery	H. E. and A. Bown, Architects, Harrogate	"
Stevington—Infants' School.....	Midland Drapery Co.	E. A. Johnson, M.S.A., Architect, Abergavenny	"
Harrogate—Additions to the West End Tavern, Otley-road.....	Joseph H. Straker	Usher and Anthony, Architects, 9, St. Paul's-square, Bedford	"
Briercliffe—Re-erection of Craven Heifer Inn.....	F. W. Henby	H. E. and A. Bown, Architects, Harrogate	"
Sherburn—Five Houses.....	Corporation	Charles Parsons, Architect, 9, Grimshaw-street, Burnley	"
Derby—Premises, East-street.....	Freehold Land Society	P. Robinson, Architect, 72, Albion-street, Leeds	"
Bramley—Eight Houses, Bell-lane.....	J. Smith	Coulthurst and Booty, 4, Albert-street, Derby	"
Corbridge-on-Tyne—Additions to Howden Dene.....	Corporation	Fredk. W. Rhodes, Architect, Upper Wortley, Leeds	"
Abergavenny—Eight Cottages, Laundry-place, Merthyr-road.....	Mrs. Sharpe	Joseph Oswald, F.R.I.B.A., Architect, 33, Mosley-street, Newcastle	"
Belfast—Four Semi-Detached Villas at Myrtlefield.....	Corporation	E. A. Johnson, M.S.A., Architect, Abergavenny	"
Bournemouth West—Nave and Aisles, Church of St. Ambrose.....	Freehold Land Society	W. J. Moore, Architect, Whitehall Buildings, Ann-street, Belfast	"
Ipswich—New Lodge, Christchurch Park.....	Freehold Land Society	Boreham and Morton, Quantity Surveyors, Sunderland	"
Croft—Farm Buildings at Middle Walme Farm.....	Freehold Land Society	J. Shewell Corder, Architect, Wimborne House, Ipswich	"
Dedham—Pair of Cottages, East-street.....	Freehold Land Society	W. Carrick, New Town, Croft, Co. Durham	"
Hurst—House and Five Cottages, Queen-street.....	Freehold Land Society	J. W. Start, F.S.I., Architect, Colchester	"
Higham Ferrers—Two Houses.....	Freehold Land Society	Joseph Heys, 196, Curzon-road, Hurst	"
Gunsley—Eight Through Houses and Shop.....	Freehold Land Society	H. Adnitt, Architect and Surveyor, High-street, Rushden	"
Carlisle—House, Howard-Place.....	Freehold Land Society	F. Moore, Architect, 40, Sunbridge-road, Bradford	"
Newport—St. John's Church.....	Freehold Land Society	H. Higginson, M.S.A., 3, Lonsdale-street, Carlisle	"
		F. R. Kempson, F.R.I.B.A., 16, High-street, Cardiff	"

# THE BUILDING NEWS

## AND ENGINEERING JOURNAL.

VOL. LXXIV.—No. 2263.

FRIDAY, MAY 20, 1898.

### HURRY IN BUILDING.

**T**HE natural process by which we prepare and assimilate the food necessary for our bodies may usefully suggest similar preparatory processes of building in what we may term "digesting" a design. As a matter of fact, the architect has very little time given him for preparing his materials. The client wants to build at once, as the season is advancing, or the business and trade must be carried on at a given time when customers return home. The consequence of this is, the architect has little time to collect his materials or digest them before building commences. The contract must be prepared immediately, and, therefore, the plans and specifications of the building have to be made forthwith. This haste in building is injurious in several ways. Let us briefly see what it means with regard to construction: A building, say, of a large commercial character has to be erected, in which all the latest improvements, such as fireproof floors, lifts, concrete in various forms, terracotta, faience, &c., have to be introduced. To obtain in due course and order the supply of any of these materials or manufactured goods, they ought to be put in hand without delay. The architect has to first make his plans and submit them to his clients; he must then decide at once, before he can write his specifications, and give orders to the contractor or manufacturer to proceed with the work. The dimensions and sections of iron beams and floors, the large drawings for the terracotta work or the supply of stonework, ought to be immediately decided, arranged, or prepared, so that no delay in delivery of goods should occur. But is it possible for the architect to prepare his contract drawings, obtain tenders from quantities, and give instructions in so short a time? The essential orders which ought to be put in hand at once are delayed till the contractor commences his work, and then all is hurried. The architect cannot prepare his iron or terracotta himself at a moment's notice: he has to make calculations of weight and strength, to draw his sections, to make his large drawings for the manufacturer of terracotta. The only practical alternative is to leave all these matters to the contractor or manufacturer, and we know the result. Stock patterns and designs are employed—there is nothing special: all very disheartening to the architect, for his work is practically handed over to men whose interest is to economise—we will not say to shirk duty.

The personal attention of the architect to the selection of materials and modes of construction is very much less given now than formerly. The large contract competition between manufacturing firms has lessened materially his personal examination of details. Take, for example, those of ironwork and fireproof construction. The testing of iron and stone and concrete are matters in which he is little concerned. If he specifies that his columns or girders are to be able to bear safely a load of so many tons, or his cement is to resist a tensile force of 353lb. per square inch, that his concrete is to be mixed with 2 or 3 of sand and other materials, it is probable that he never has the opportunity of really witnessing the tests, or assuring himself of the results: they are left either to the clerk of works, if there is one, or, in most cases, the contractor undertakes the duty. And we know the consequences. Are not the disastrous failures

of buildings, the sudden collapses of which we have had so many of late, owing to hurried and unexamined work?

But there is another kind of supervision in addition to that in selection and testing of materials which are supplied to the building. We mean the supervision of structures—the execution of the work on the building. We fear a good deal of this is neglected unless a clerk of works is employed, or perhaps the architect makes his visit at some time when the work has been completed or covered up. Perhaps piers of brickwork to carry a girder for a front are completed, and the iron girder is fixed. The architect has not seen the kind of bond used, the filling in of the core with inferior bricks, the foundation or the bearings; or it may be, as in the case of the unfortunate mansions at Westminster, a concrete floor or roof has been begun and finished, and the centring is "struck" before any inspection has been made as to the composition or quality, or setting of the concrete. Considerable progress may be made in a building in the course of a week or two, terracotta piers may be erected without the cavities being filled with concrete, and the weight thrown on the chambered blocks may cause fracture; iron columns may be put up and covered up with stone or granite casings before the architect sees them. If the contractor was bound under penalty to give notice to the architect whenever such work is in progress, or before it is completed, a great many building failures would be averted.

Hurry in building is the cause also of many disappointments in architectural design. It means haste in preparing working drawings, ill-studied details, bad proportions in some cases; there is no time for the elaboration of details, and they are left to take their chance. The contractor is thankful of course, as a rule, for he can give his own instructions, and between his not too critical eye, and the apathy of his workmen, the small eighth-of-an-inch scale drawing is interpreted to mean quite another thing than was intended. Imagine, if we can, what it means in the execution of a dormer, a gable, a cupola, a window, or some special feature of the design. The most artistic looking sketch or suggestion in the elevation may turn out, when too late, a veritable piece of ordinary "jerry" or Royal Engineers' building; what was intended to be chamfered or moulded is left plain, stone is taken for wood in mullions, "matched" deal boarding for structural timber or stone. In short, the ideas and aspirations of the architect in his design may be so completely disillusioned that he shrinks with horror from a building of much promise that has turned out so little to be proud of.

### PICTURES AT THE ROYAL ACADEMY.

[FOURTH NOTICE.]

**T**WO very pleasing works in Gallery VIII. conceived in a decorative spirit are worth notice here before we pass on. One is Florence Small's picture, "A Dirge" (618), five young girls walking in procession singing a plaintive song. Their shadowed heads against the light background lends a poetical charm to the work. No. 629, "The Song of Ages," by Ethel Wright, is another charming composition—a group of sweet-faced maidens; the centre one, clad in embroidered cloak, is singing as she holds an illuminated scroll in her hands. At her side a maiden holds a lily, and the background is made up of white blossom of lilies. There is much delicacy of colour and refined devotional grace in the work. Above it Sigismund Goetze's "Eloquent Silence," a long panel subject, with a recumbent figure of a man representing Death, with winged figures over the body, is bold and decorative, and is intended for the chancel of St. Botolph's

Church, Aldersgate. William Stott's embodiment of Keats's "Ode to Autumn" is a poetical conception of autumn—a beautiful woman reclining in rich purple-coloured drapery amidst corn and other ripe fruit and grain. After this digression we resume the order of galleries.

The Ninth Gallery contains a few pictures of merit. Smaller in size, the work in this gallery is not less important. Carl Schloesser has a carefully painted piece of *genre*, "An Old Master" (666), a young lady standing by the side of an elderly professor—a very sympathetic rendering. As a marvel of finish, reflection on surfaces, and technical detail, Jessica Hayllar's work is always sure of a welcome. In this work, "A Perfect Angel" (683), the painter shows in the foreground a child with white wings, presumably the origin of the title; but the merit of the picture is in the drawing and perspective of the interior. The adjoining apartment is rendered with all the consummate art and subtle finish of this lady painter. The glazed prints or engravings hung on the wall, the reflected light, the piano, and accessories are executed with a remarkable technical finish and minuteness. Albert Goodwin's (690) "Haven under the Hill"; Bertram Priestman's "Grazing"; Andrew C. Gow's picture, "The Signal" (700); John Brett's delightfully-painted coast piece in North Cornwall, showing reefs of rocks at low water (715); Charles Kerr's "Ste. Jeanne d'Arc"; Dudley Hardy's subject, "The Widow"; Florence Small's charming study of a head on pale gold ground (755); and the dextrous figure-study, "The Relic," by Howard Pullar, are works we can only glance at. J. MacWhirter has a placid view of the "Lake of Geneva from Chexbres" (753), painted in his inimitable manner. There is also a characteristic portrait-study of Sir Edward Burne-Jones, Bart., in his studio-dress at work on a piece of wall decoration, by Philip Burne-Jones (790), and some works by Mark Senior (793), Walter Sickert (801), A. M. Rossi (839), Alfred Waterhouse's little landscape "Ashhampstead Common" (866), Flora M. Reid (860), Lexden L. Pocock (842), &c.

Herbert J. Draper's picture, "The Lament for Icarus" (903), is a masterly composition, almost Leightonian in its modelling and method, full of harmonious colour. The sea nymphs are ministering to the drowned Icarus, the myth of which is that he took a winged flight from Crete to escape the anger of Minos; but the sun melted the wax which cemented his wings, and he fell into the sea and was drowned. The hapless youth is shown with these wings in the midst of the nymphs, who pity and support him. One of the important subject-pictures, painted with his usual scholarly and refined manner, is E. Blair Leighton's "A King and a Beggar Maid." The painter shows a handsome young king, clothed in the richest embroidered garments, offering his crown at the feet of a beautiful girl, who is standing before a canopied and richly-carpeted throne. In the distance are seen the attendants of the king. The subject is not so interesting as one or two other well-known subjects of this careful painter of historical episode; but the accessories, technical qualities, and colour are faultless, if too conventional. "Sisters" (916), by A. Chevalier Taylor, is in this master's best style. The scene laid before us is an elegantly furnished drawing-room filled with choice flowering shrubs, arum lilies and blossom. At a Louis Seize table, a young lady, pensive-looking and full of remembrances, sits watching her younger sister, who is in white dress and is receiving the attentions of a young man. The line of the poet, "A sorrow's crown of sorrow is remembering happier things" explains the painter's meaning. The drawing and arrangement of the figures are graceful and the

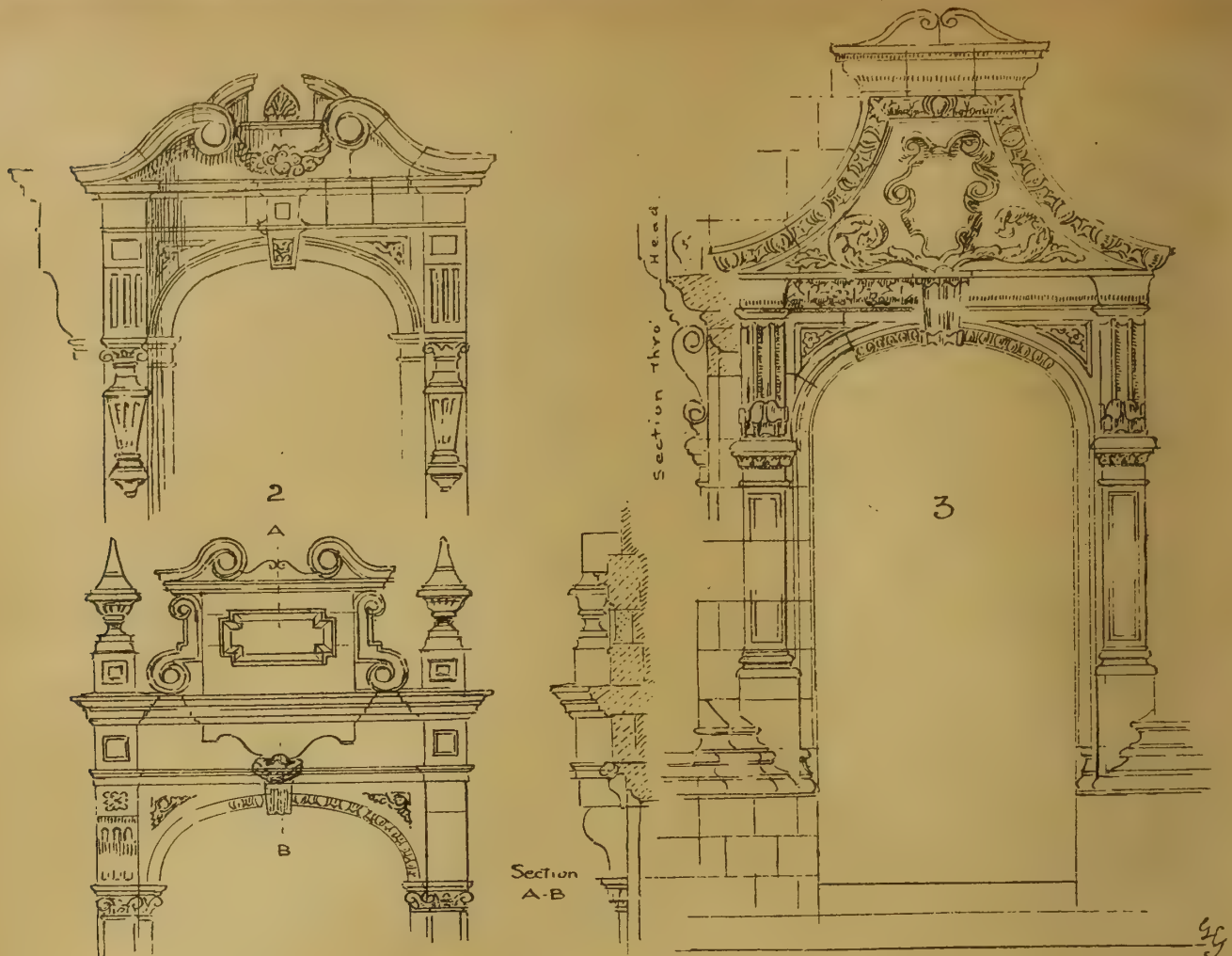

colour pleasing; and the painter has given us something more than a commonplace work of *genre*. Rowland Holyoake's "Fish-Washing on the Farøe Islands" (925), a number of fisherwomen washing the flat-fish, is admirable in colour and natural, one of the best studies of the kind.

A luminous and decorative subject is Charles F. M. Cleverly's "The Angel of the Grail" (918), with which we may compare "The Vision of the Sangreal," by Joseph W. Forster, in the same gallery (927), painted with a truly religious feeling. Then we have an imaginative symbolical subject by Albert Goodwin, entitled "Under the Roof of the World," a sublime medley of lofty mountains and peaks and edifices—a sort of dreamland or Arabian Nights vision painted with some power. H. H. La Thangue, whose work we have noticed in other galleries, has here another large realistic work, "A Sussex Cider Press," a man and woman turning the handle of a press, the gleam of warm sunset lighting up the toilers and the rich liquor which falls into the pail. There is light and shade, breadth and strong colour in this picture in country life. The man and woman are exerting their whole strength on the lever as the turbid stream issues forth. But why the great scale? The ruddy sunlight and the drawing of the figures are worthy of this new Associate's work; perhaps this is his best contribution.

Alfred East's large landscape, "Opulent Autumn" (930), is a grand study of evening sunlight as it bathes with its warm light the trees and river. The painter generally makes his lights subordinate in quantity to his shadows. We have here an autumn landscape in which the foliage is lighted on its near side, the shadows being comparatively few. Illumined foliage against a dark background is rare with painters, and when it is attempted the effect is often lost. Mr. East

has preserved the breadth of his sunlight. In quite another tone is Yeend King's fine view of "Blackmore Vale" (898)—distant green meadows and trees and wooded banks sloping down to a glistening river which runs at the foot of the hill. The handling of foliage is delicate, and true to nature. The landscape of B. W. Leader in the next gallery, called "Surrey Sheep Pastures," is another of the beautiful series of landscapes which the new Royal Academician has given us this year. It has all the careful modelling and finished beauty of his other work. We see a real English or Surrey rough common or heath, in which a piece of placid water or pond occurs in the foreground. There is no golden sunset or tranquil evening effect; it is a sturdy and thorough English scene of a wild tract of country in hues dear to the admirer of our wild heaths. The ruts of a cart-road round the pond are filled with water which reflect the sky. Beyond, low distant hills bound the horizon. Thomas Somerscale's seascape, "A Coming Squall" (959), a deep blue sea with crested waves and a sailing ship reefing her sails, is a clever piece of sea-painting and reflection; and Harry Van der Weyden's "Passing Clouds" (966), a shelving beach of sand over which waves are breaking and spreading in limpid layers over the sand, is worth notice among many indifferent works. There is breadth, freshness, and atmosphere in J. Aumonier's picture, "A Wide Pasture" (960). One of the few pictures of merit is Claude Hayes' "Out in the Cold" (971), three old horses seeking shelter from the cold frosty air, near the fence of an outhouse by the wayside, on a cold, dreary winter night, the road covered with snow. There is a sense of forlornness and hard life in these three neglected horses, left after their labour, that appeals to the sympathy of the observer. The painter has awakened a chord of feeling. The con-

spicuous canvas of Eugène Burnand, "Group of Lansquenets—Swiss Soldiers of the 14th Century," has little of interest except as a *tour de force* of colour. The figures are in buff and red uniforms in a wide landscape.

"As Tall as Mother," by James Hayllar, is a domestic study. It represents a neat cottage interior lighted by a casement window. An aged pair—grandfather and mother—are at a small table, on the other side of which a young daughter stands, measuring herself against her mother, back to back. The soft evening light is cast upon the group. It is needless to say the work is executed with patient attention to details; that the expression and character of the grandparents and the younger members of the family are painted with great care. Hilda Montalda has a pleasing study, "On the Venetian Lagoons," full of sunlight, the dark sail against the luminous sky and the boat and its three occupants skilfully painted on the gleaming water. Frank Bramley's large picture of "A Dalesman's Clipping"—a Westmoreland scene of sheep-shearing—is bold and vigorously painted. We do not see much to remark in John H. F. Bacon's large interior subject. "The Ring" is rather a commonplace subject: a graceful young lady in a long white robe, or bride-elect, is standing looking at a ring near the window in an evening light, while the father and mother, seated by the fireside near a table lighted by a couple of lamps, are watching her with parental solicitude. The figures are gracefully drawn, and the waning, half-artificial light skilfully shown. "The Haven," by J. Langton Barnard (1002), is a pleasant restful coast view, with a gleam of sun on the steep white cliffs which rise up from the beach. Near it, J. Walter West's "Married for Love"—a young couple in a chaise descending a steep, hilly road—is painted in a rather flat style.

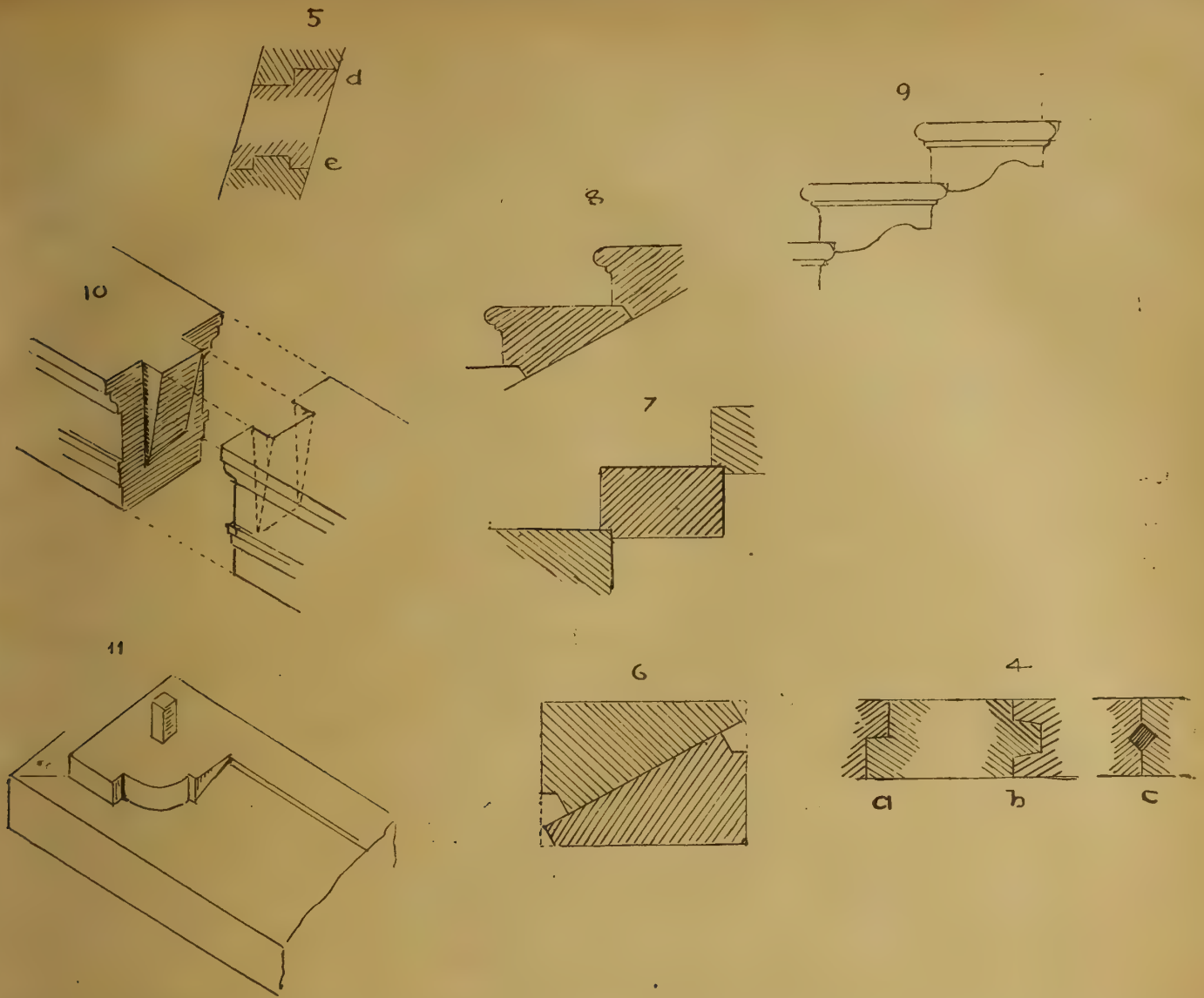

The sudden descent—does it presage misfortune in their married life? David Murray's large landscape, "Flowers of the Field," a field covered with scarlet poppies, is rich in colour and broadly treated. There are many other oil paintings of equal merit; but we have only attempted to notice leading pictures. The Water Colour and Black and White Room we must reserve for another article.

MODEL SPECIFICATIONS.—XIII.

MASON.

THE mason's work ought to receive particular attention. Every labour or detail that is not shown in the drawings ought to be described, as, for example, the description of each kind of stone, its quality, the quarry or any particular bed, how the stone is to be set, with what mortar, what joints are to be used, whether it is to be "tabled" or "joggled," or doweled or cramped, how it is to be finished or dressed—whether pointed, hammer-dressed, axed, rubbed, dragged or scabbled? These terms ought to be properly applied, and each class of stone has its own modes of dressing. Thus grey granite, like many of the hard Cornish varieties of stone, is worked by splitting with wedges, and then scabbled by a hammer with a cutting face, then picked with a pointed hammer to give it a face. Picked work is better finished than scabbled work with a hammer. Portland or York stone is "rubbed," to form a fine face, with sand or gritstone; softer stones, like Bath, are "dragged." This labour is performed with the aid of a saw-like tool or

comb which is traversed over the stone in all directions to remove the saw and chisel marks, and produce a smooth surface. In tooled work the chisel-marks cross the width of stone. A great deal of the best Mediaeval work is finished with the chisel, or random tooled, or boasted by the chisel in the harder varieties. Many stones defy small-tooth-comb work or dragging. In old buildings the moulded work often shows that the masons followed the lines of mouldings, or chiselled them as a wood-carver would—never across. Mr. Neale describes the stonework at St. Alban's Abbey as finished by the axe by the Normans, chiselled during the Transition Period, "bolster-tooled" during the Early English, claw-tooled during the Decorated, in which last-named period the mouldings were scraped. Generally for hard stone finish the labour may be described as "boasted," or tooling at an angle, or "tooled," and for soft stones "dragged" or "combed." There are also "pointed" work for bed and side joints to produce approximately true surfaces, executed by a pointed tool or punch, and often used for quoins and plinths to produce a rough face with a chisel draught round the edges; vermiculated work used in quoins; "broached" done by a chisel or punch, "droved," &c., all of which terms should be carefully applied. We shall give examples of these. As to the qualities of stone we refer the reader to the several textbooks, chiefly "Notes on Building Materials." In specifying Portland stone care must be taken to name the particular bed. The most valuable are Whitbed and Basebed, as they are even in texture and durable, but

for hardness and durability Whitbed is preferred, as the Roach kinds are full of shells. Perhaps even greater care is necessary in specifying Bath stone, as many of the kinds in the market weather badly in towns and seaside places. For ashlar work and carving, Box Ground, Corsham, and Combe Down varieties are used; the yellow Mansfield, a magnesian limestone, is also even-grained, suitable for carving. Other useful limestones are the Ancaster, Ham Hill, and Bolsover. Stone should also be specified to lie in its natural or quarry bed. The average beds or depths of stones should also be specified, and the kind of mortar and pointing.

In ashlar facing, the stones will vary in size from 12in. in height and 8in. or 9in. in thickness, and of lengths from 18in. to 30in. When the ashlar is of the same thickness, the backs of the stones are often inclined to the face, to give a bond or lap; but this plan, as it leaves vacancies, is objectionable. In some parts of the country where stone is cheap, a rubble backing is used; but unless the rubble is composed of large stones and few mortar joints, the wall is liable to bulge outwards, owing to the settlement or shrinkage of the backing. In Scotland and the North, we find this rubble backing; but great care is used to prevent settlement by careful bonding or "through"-stones, and the ashlar facings are excellent in quality. These bond or "through"-stones ought to be put in alternately, the "through"-stone of every succeeding course being placed between the two below. In London and the South, brick backing is generally used; but the same care as to mortar joints and bond are

necessary to be observed. As to how many courses of bricks the stone courses are to be cut, opinions differ. Sometimes six courses of brickwork is specified; in all cases the ashlar should be equal to a given number of brick courses, so that the bond may be made easy, and separation of the face and backing prevented. With rubble backing it is necessary to avoid any great difference of height between the ashlar and rubble. Thick and numerous rubble joints are sure to lead to bulging and separation of the face, even if "headers" or "through"-stones are used. The ashlar should have level beds, and the vertical joints should be carefully dressed true and square for some distance from the face at least; but the tail ends of the ashlar may be irregular, and sufficient headers used to bond well with the rubble. The ashlar should have a depth of bed equal at least to its height, so that a course of stones 12in. high should go through the wall that distance; but this rule is not often observed, and facings of 4in. or 6in. thick are often used. A wall of this kind is weak and apt to bulge. Walls of this composite kind should be thicker than those built of brick or squared stone throughout.

There are many joints used in masonry. We illustrate a few of them. Fig. 4 shows three methods of joining stone used in landings, &c. The second, *b*, is a joggle-joint, already explained, and which is often used in terracotta. The tongue is cut slightly tapering; it fits into a corresponding groove worked on the other edge, and is run in with cement. It forms a strong joint for landings. A rebated joint, *a*, is also frequently used for copings and landings, and is used as a "bed-joint" in stone spires (see Fig. 5). Another common mode of jointing is shown at *c*. Two grooves are cut on the opposite edges of the stone, and the cavities are run with lead or cement. Slate dowels are sometimes inserted, run with cement. In Fig. 5 we give two similar kinds of joint, as at *a* and *b*, used for the stones of spires or cupolas. The first is a rebated or stepped joint, and the second a joggled or tabled joint. In cutting stone steps, it is usual to cut two steps out of one stone (see Fig. 6), a plan which saves material and insures accuracy. Figs. 7, 8, 9, and 10 illustrate the jointing of plain and spandrel stone steps. The sketches 1, 2, 3 show three other examples of decorative terracotta door-heads. The last represents one of the doorways in the Birmingham Law Courts. For ordinary buildings the clauses may run as follows:—

1. *Generally*.—The whole of the stone to be of the best quality of its respective kind, and be approved by the architect, free from vents, sand-holes, and other defects, and to be laid on its natural bed. The Portland stone to be "Whit-bed" of the Portland quarries. Or, if Bath, to be from the Box Ground, Corn Grit, or other approved quarries. Or—

The stone for external purposes to be of the best quality Portland (or of a superior description of "Whit-bed" stone from quarry), free from veins, vents, shakes, and other defects, laid on its natural bed in fine mortar, finished with a "rubbed" face, and cleaned down at completion and left perfect. Or—

The stone to be of the best Bath stone from the Bath Stone Firms, Ltd., or from Box Ground, or Combe Down quarries, laid on its natural bed, and cleaned off. The plinths, bases of columns, sills, to be of the former (or to be from the Darley Dale and District Stone Co., or W. H. and J. Slater's quarries, Derby), and to be bedded and jointed in fine mortar, and finished with a dragged face.

Every stone to hold its full length and height square to the back.

The following are samples of clauses for plain ashlar work:—

2. *Ashlar*.—The external walls or front of building to be faced with Portland (or Corsehill stone) ashlar, in courses 12in. high, 6in. (or 9in.) on bed, finished with a fine rubbed face, laid in lime mortar, bonded to brickwork every 3ft. (or 5ft. apart) on each course; the bonding stones to be at least 2ft. superficial in face, and to go through the wall. The joints to be not more than  $\frac{1}{2}$ in.

(or  $\frac{3}{4}$ in.) thick, and bedded  $\frac{1}{2}$ in. from face in lime putty. Or—

The ashlar to be in courses of varying height to suit the brick backing, the stretchers to be 4in. (or 6in.) deep, and the headers 9in., one header to every stretcher, and all the joints to overlap. The faces to be rubbed, and the ashlar to be laid in best lime and sharp sand mortar, and to be well grouted at every course. If cramped, gunmetal cramps to be used, run with lead. Or—

Face the external or front wall with Bath stone coursed ashlar from Corsham Down (or Combe Down quarries) in courses 12in. high, and averaging 6in. (or 9in. on bed), finished with a finely-dragged face, with a "through"-stone every yard superficial, or every 3ft. apart in each course. The joints to be not more than  $\frac{1}{2}$ in. thick, and bedded  $\frac{1}{2}$ in. from face in lime putty, neatly pointed and cleaned down at completion. Or—

The walls (or front) to be faced with Bath stone in random courses varying in height from 4in. to 14in., and from 4in. to 8in. on bed, in lime mortar, bonded every yard superficial with a stone 2ft. superficial right through the wall. The ashlar to have finely-dragged face. Or—

The ashlar work to be of the best Portland, laid in courses of 15in. high and 12in. in thickness, with beds and joints, hammer-dressed, and squared to accurate planes with one header to every stretcher.

No pinning, wedging, or filling-in will be allowed. The whole to be set in the best lime and clean sand putty, and neatly pointed as the work proceeds. The joints not to exceed  $\frac{1}{2}$ in. thick.

3. *Labours, &c.*—Perform all mitres, stopped ends, splays, rebates, grooves, chases, sunk, weathered, and throated work, and provide and fix the necessary copper or gunmetal cramps and dowels. No iron cramps or dowels to be used.

Mr. Leaning gives the following useful clause for quarry-worked stone:—

4. *Quarry-Worked Stone*.—"The quality of stone shall be equal to a sample deposited with the architect. The stones shall be fitted together ready for setting, and shall include all necessary joggles and holes for dowels. The stone shall be marked with numbers for identification, shall be accompanied by a key-plan, and shall be packed and delivered at the works at convenient times: all the stone required below level of ground-floor (here fix date), all the stone required between ground and first floor before —, &c. (If the contract is made with stone merchant, add)—The stone merchant shall be responsible for and make good any damage in transit."

5. *Plinth*.—The plinth stones of Portland "whit-bed" to bed the whole thickness of wall, 18in. (or 2ft. high), and 9in. on bed, with bonder stones every 5ft. apart, and to project 3in. (or more) from face of wall (see detail). Or—

Put all round the building a Portland stone rubbed plinth 2ft. high and 8in. bed, plugged with lead. Or—

Put round building an Aberdeen granite plinth 2ft. (or 2ft. 6in.) high the whole thickness of wall, with chamfered or ogee base-moulding, projecting 3in. from face of wall, tooled or hammer-dressed, and plugged with lead.

6. *Quoins*.—The quoins to angles of building or front to be alternately 15in. and 9in. on face, and 12in. (or 15in.) high, with moulded or chamfered edges (see detail). Or—

The quoins to be plain raised blocks, with square channel joints, worked below the top bed. (In Gothic work the quoins are of random sizes and heights, and these several kinds should be specified, and the dimensions given).

#### ROYAL INSTITUTE OF BRITISH ARCHITECTS.

THE fourteenth ordinary meeting for the present session of the Institute was held on Monday evening. In the absence of the President, Professor Aitchison, R.A., due to a severe attack of gout, Mr. H. Louis Florence, vice-president, took the chair. There was a large attendance of members and visitors, the latter including Mr. Jan Stwyt, of Amsterdam, who was cordially welcomed by the chairman. Among the list read of nominations for membership, the name of Sir E. J. Poynter, P.R.A., proposed for election as an Hon. Associate, evoked a round of applause.

#### THE LIBRARIES OF THE MIDDLE AGES.

A paper on this subject was read by Mr. T. G. JACKSON, R.A. The lecture was illustrated by examples of actual Mediaeval ironwork and volumes and numerous lantern-views, giving

exterior and interior views and details of various buildings described. In his opening remarks, the author contrasted the modern free library, equipped for the convenience of readers, with the libraries of the Early Middle Ages, pointing out that in Early Mediaeval days, with books so rare and precious that the greatest care was necessary in their storage, the only large collections must have been those in the cloisters of the religious houses or collegiate churches. The earliest went back to the time of St. Benedict, in the 6th century; though there was one at Jerusalem in the 3rd century, and the church at Hippo inherited the books of St. Augustine, in the days when the great Roman libraries were still in existence. It was on the model of the old classical libraries that those of the churches and convents were framed. Of the two kinds of private libraries among the Romans—the simple and the luxurious, which were both described—the simpler plan was adopted by the churches and convents as more fitly serving their needs, the books, for the most part, being kept in chests or locked up in presses. As the collections increased, the books were divided into two classes: one being kept as a reference library, and placed in presses in the cloister where students could come and consult them, and the other consisting of volumes which were lent out to the monks to read. In this connection the lecturer quoted a curious rule made by Archbishop Lanfranc in 1080 for the English Benedictines, who were allowed to borrow and exchange one volume per annum. As collections increased, accommodation had to be made for them. At Christ Church, Canterbury, in the 14th century, the books, which had increased to 698, were dispersed in cases throughout the convent wherever space could be found. The inconvenience of this to students requiring to refer from volume to volume led to the provision of a room devoted to books, and with conveniences for studying them. Between 1414 and 1443 a library was built over the Prior's Chapel at Canterbury by Archbishop Chichele, and another at Durham, over the old sacristy, by Prior Assington; in the abbeys of Cîteaux and Clairvaux similar provision was made over the scriptorium between 1480 and 1503; at Saint-Victor, at Paris, between 1501 and 1508; and at Saint-Germain-des-Prés, about 1513, over the south cloister. Buildings specially to hold their libraries, and to afford easy mode of consulting their contents, were first erected by the universities and colleges. The

OLDEST STRUCTURE OF THE KIND IN ENGLAND, perhaps in Europe, is the old library of the University of Oxford, which still retains many features of its original form. This structure, rarely seen by visitors, and even unknown to the majority of Oxford men, is a two-storied building situate on the north side of the choir of St. Mary's Church, adjoining the tower at one end, and separated from the body of the church by a narrow courtyard. Having glanced at the way books were kept, used, and lent at Oxford prior to the erection of this building, the most interesting edifice in the university, the lecturer gave a sketch of its foundation by Thomas de Cobham, Bishop of Worcester, about 1320, and some incidents in its early history, following with a description of the interior, furniture, and general arrangements. Long desks were placed at regular intervals at right angles to the walls on which the volumes lay on their sides. A bench was fixed in front for the reader, and a window came between each pair of desks to light that pew or cell. Every volume had a metal slip riveted to the front edge of the board forming one cover, to which was attached a light iron chain of the requisite length, having at the other end a ring. This ring ran up an iron rod which was carried along the top of the desk, and was secured at the end by a hasp and padlock to prevent the ring being drawn off. The foundation of Bishop Cobham's library was succeeded shortly afterwards by that of the

#### LIBRARY OF DURHAM COLLEGE, OXFORD,

by Richard de Bury, Bishop of Durham (1335-45), a bibliomaniac, traveller and scholar, and withal a humorous writer. The books bequeathed by De Bury to the college were kept for many years in chests under the custody of scholars deputed for the purpose. At the beginning of the 15th century a library was built, and regularly furnished with book-cases or settles inclosing pews or studies between them, where the books were chained. When Durham College came to

an end at the Dissolution, its old buildings were utilised by its successor, the present Trinity, and the old Library of Durham College still serves as the Library of Trinity College. William of Wykeham's New College at Oxford set the fashion for all future collegiate buildings at either University in provision being made for every department, and thenceforward every college had its library as an essential part of its plan. Though books were few, the rooms devoted to them had to be very large, the chaining of the books to the desks making it possible to have only very few on each desk. Soon, as books increased, shelves were formed behind the desks, tier by tier, until at last, in the 17th or 18th century, they reached the ceiling. The appearance of the fittings before that time can be well seen in the old library of Merton College, Oxford. Of chained libraries, which the lecturer treated at some length, there are at least three extant in England, that belonging to Hereford Cathedral being the most ancient and perfect. Old chains, hasps, and staples belonging to Hereford—specimens of the actual fittings of a

#### MEDIAEVAL CHAINED LIBRARY,

were exhibited by Mr. Jackson, and the method of fixation explained. All Saints' Church, Hereford, and Wimborne Minster also possess chained libraries, the former founded at so late a date as 1715. But the finest in the world is that of San Lorenzo, Florence, the great hall of which was designed by Michel Angelo in 1524, to contain the collection formed by several generations of the Medici. The lecturer then touched on the difficulties of consulting books in the old chained libraries. Shelves for the ever-increasing number of books had been provided, but desk accommodation remained as before. One student occupied on a volume prevented three or four others getting access to the books. This led to the library-rooms being enlarged. Interesting reference was made by the lecturer to Duke Humphrey's connection with Oxford, and to his splendid benefaction of over 600 books to its library in the earlier half of the fifteenth century. The new acquisitions made more commodious quarters imperative, and in 1444 the University resolved to build an upper story to the new Divinity School, which, begun in 1426, was being slowly carried towards completion. The change was at length made in 1480, when the University Library was removed from the old solar or upper chamber at St. Mary's to the new solar over the Divinity School. The lecturer then glanced at the subsequent fortunes of the Library, which was despoiled of the most valued of its treasures by the Commissioners of Edward VI., and munificently enriched, altered, and enlarged by its second founder, Sir Thomas Bodley, at the end of the 16th century, since whose day the venerable central room has remained practically unaltered—the most attractive spot to the student to be found anywhere. Chains were bought for the Bodleian Library as late as 1751; it was not till 1757 that this method of securing the books was abolished. Other libraries described more or less fully were that of St. John's College, Cambridge; the new library finished by Sir Christopher Wren in 1695, which forms the western side of Nevill's Court at Trinity College, Cambridge—a stately building, both within and without, a triumph of architecture, which would suffice by itself to establish Wren's reputation as an artist; and the fine building of the Radcliffe Library, completed by James Gibbs in 1747. In conclusion, Mr. Jackson showed views of a library of his own planning at Uppingham School, in which he had tried to combine the two arrangements of cases against the walls and cases breaking out from them.

Mr. J. W. WILLIS CLARK, M.A., in opening the discussion, said it was to the rules of the Benedictine order that we were indebted for our modern public free libraries. A library did not, it was true, form any part of the original plan of a monastery; but it was found as books increased in numbers that they could not all be kept in the armoire in the cloister, and a special room was accordingly set apart for them. This was the history of the libraries at Durham, at Cîteaux, and elsewhere, and thus the monastic collections of books were prototypes of our leading libraries. The monastic buildings were always long narrow rooms, with windows equally spaced in the walls, and between these windows, as Mr. Jackson had shown, the books were arranged. Although the original collectors of books had all been dispersed from the catalogues and descriptions which had

come down to us from those at Clairvaux and elsewhere, we could make out to a certain extent what the bookcases were like, and knew that in many cases there were two shelves placed back to back, the set of four forming a "bank," and that desks were provided for readers. He had never yet been able to discover any remaining examples of a book-press or desk, although he had travelled all over the greater part of Europe searching for them, and he feared it was almost impossible to hope to find one preserved. There were plenty of traces of the great care taken by the monks of their manuscripts; indeed, the writings generally ended with an injunction to take care of them or a curse would be pronounced. It was evident that the monks did not mind lending their treasures provided proper pledges were given that they would be returned in good condition, and it was this custom which provided us with the first public libraries. At Assisi the monastery had a distinct lending library of no fewer than three hundred volumes. During the French Revolution the inhabitants of the towns recognised the value of their great libraries and took care of them. We could find out with tolerable exactness how our Mediæval libraries were fitted up by studying the University records and remains, especially those of Oxford, which seat of learning was always richer than its sister at Cambridge, for it would be incredible that the monasteries should not have copied the university fittings as they did their statutes. It was clear that the modern bookcase was evolved from the monastic one. It should be remembered that Sir Christopher Wren first provided and fitted up a library at Lincoln Cathedral, where he arranged the bookcases against the wall and not at right angles to it. Wren probably derived his idea from the famous library founded by Cardinal Mazarin in Paris in the building now replaced by the Palais de l'Institut on the left bank of the Seine, for we knew Wren studied in this library a good deal. Mazarin, in turn, was indebted to the library of the King of Spain at the Escorial; the latter famous Royal library, in truth, made a great stir, and its arrangement was widely copied. At Lincoln, there were four splendid double-desks, with great poppy-head ends, belonging to Wren's library in one of the cloisters. There was a very similar library at Wells Cathedral over part of the cloisters, which was refitted by Dean Bathurst of Oxford; it had been said to be a late survival of a chained library; but there was no trace of chaining on any fitting or book, nor were there any payments in the records for chaining.

Mr. H. W. BREWER said he came across the will of John Carpenter, the founder of the City of London School, who left an exceedingly good library for his times. He bequeathed the bulk of the books to Sir Richard Whittington, and stipulated that they should be chained, but so kept as to be accessible to all poor scholars of the city of London who wished to consult them. He further bequeathed to his relative, John Carpenter (afterwards Bishop of Exeter), "that book of architecture given to me by William Clee," who had been controller and master of works to Henry V. and Henry VI., and who built the fine hall or palace at Eltham, and carried out various works at the Tower of London and the Sheen Palace. This William Clee, the architectural author, had stipulated, in a curious letter still in existence, and addressed to the Privy Council of Henry VI., that £1,000 should be provided for him at Eltham, remarking that for building the kitchen at the Tower of London he did not receive so much as forty pence. It would be interesting to know what became of these books of John Carpenter, and he for one should be glad to see some of them find their way into the Institute library.

Mr. H. H. STATHAM proposed a vote of thanks to Mr. Jackson, remarking that it had been one of the most delightful papers they had had for a long time, and one which traced the history and development of libraries in their practical arrangement. The exhibition that evening of the actual chains and fittings from Hereford Cathedral give an air of realism to the lecture, which brought them into touch with Mediæval readers.

Professor G. BALDWIN BALDWIN, of Edinburgh University, seconded the vote of thanks, remarking on the exceptional interest of the paper, which, he said, was quite in accordance with the best traditions of the Institute. They owed a great debt to the monastic library, for by its agency not only the sacred, but also the profane

treasures of literature had been preserved to us, since we find by its catalogue that the library of the monastery of St. Gall contained profane as well as sacred books. A plan of a monastery made in the early part of the ninth century showed a building used as a scriptorium below and a library above, a window being arranged between every pair of desks.

Mr. E. W. HUSON observed that an important library had not been mentioned—that which was founded in Paris by Saint Louis on his return from the East, was attached to the north side of La Sainte Chapelle, and was designed by the same architect, Pierre de Montreuil. He should like to ask if anything was known of its form and arrangement; it seemed to have had an apsidal east end, and to have been three stories in height, the basement being used as a sacristy, the middle floor as a chapel, and the upper room as a storehouse for books. The well-known library at the Conservatoire des Arts et Metiers was an apartment designed by the same architect, but was the refectory of the Benedictine monastery of St. Martin des Champs; the magnificent hall utterly refuted the libel that buildings in the Gothic style were necessarily defectively lighted.

Mr. W. H. ST. JOHN HOPE observed that if architects and students would keep their eyes open when visiting Benedictine and Cistercian buildings, they would find in many cases abundant traces of the provision for reading and lending books, often in quiet recesses in the east walls of the cloisters. In some cases there were two such libraries, one a small one for novices, and a larger one, but still only 5ft. or 6ft. square, for brethren. There was such a library at Kirkstall, another at Worcester, and a similar one formerly existed at Meux Abbey, now entirely destroyed, of which the inventory was extant. At Furness a large cupboard existed in precisely the same position as at Kirkstall, and at Castle Acre and at Fountains there were traces of an upper story approached by a wide and ample staircase. We obtained glimpses of these libraries from inventories such as at Titchfield, Hants, and he had a list drawn up by a monk at Canterbury, showing the books which needed chaining and those which needed repairs, and from this Mr. Willis Clark was able to reconstruct the library and its books.

Mr. WILLIS CLARK added that an ancient library had lately been destroyed in Paris to make way for the Ecole Polytechnique. Near the well-known Bibliothèque de St. Geneviève, in Paris, there was till recently an old library, cruciform on plan, which had been turned into a dormitory for boys. He feared that all the conventional libraries of Paris had now disappeared.

The vote of thanks having been passed by acclamation, Mr. JACKSON briefly replied, remarking that catalogues of old libraries always possessed a great interest. There was one of Oriel College, Oxford, which Dibden described as a roll; but it still existed as a bound book, and in it, owing possibly to the frequent loss of illuminated title pages, all the volumes were referred to by the first word on the second page. [Mr. Willis Clark: That is the uniform custom.] As an architect, he was naturally jealous of the reputation for originality of Wren, and he could not allow that Wren was indebted either to Cardinal Mazarin or the architect of the Escorial for his treatment of Trinity College, Cambridge. The lower part of the wall had to be left unpierced by the architectural requirements, and it doubtless occurred to Wren that it would be a good opportunity to line the blank wall up to the window level with bookcases.

#### THE SURVEYORS' INSTITUTION.

AT the ordinary general meeting of the above society, held on Monday evening last, a paper was read by Mr. Herbert Trustram Eve, on the subject of compensation values, as between incoming and outgoing tenants of agricultural holdings, for unexhausted improvements. The subject is one which bears but little on the branch of the surveyor's profession, with which our readers are chiefly connected; but the paper contained an interesting series of tables which, when embodied in the *Transactions* of the Surveyors' Institution, cannot fail to be a valuable guide to those who have to do with the valuations of agricultural property, which under some recent Acts may include buildings. The author avowedly approached the subject from the point of view of a surveyor, and not

from that of an agricultural chemist, and based his arguments mainly on a recent article by Sir J. B. Lawes and Sir J. H. Gilbert. He gave the usual methods of ascertaining compensation, founded on the cost of the food consumed upon the farm, and presumably remunerative to the incoming tenant in the shape of manurial value, and advocated a system by which these values should be founded on the varying prices of the three principal cereal crops, as was done in the calculation of the value of the tithe-rent charge under the Commutation Act of 1836. This was a practical basis which could be understood by a farmer, who could not be expected to follow the ever-varying market values of chemicals, such as ammonia, phosphoric acid, and potash, which formed the basis on which the chemical valuation must be made. A combination of the two methods of calculating the value of additions to the fertility of a farm, for which the incoming tenant could reasonably expect to be made to pay, and for which the outgoing tenant might well claim compensation, was advocated by the author. Many instances were given of differences in the value of feeding stuffs, varying with the quality of the land, the sort of stock fed, the number of years of "continuous good farming," and other conditions, and, on the whole, the paper seemed to be one which would be most useful for reference to the land-agent surveyors.

A discussion followed, in which Mr. F. J. Smith, Mr. G. D. E. Wigley, Mr. E. A. Rawlence, Mr. F. J. Brown, Mr. T. A. Dickson, Professor E. Kinch, and Mr. J. Looker took part, and the further consideration of Mr. Eve's paper was adjourned to the next session of the institution.

"BUILDING NEWS" DESIGNING CLUB.

A HILL-SIDE BUNGALOW.

**A** RESIDENCE such as the following particulars provide for presents a decidedly attractive subject for the display of taste and ingenuity: the restrictions are few, and the chances for artistic originality are unfettered, provided all attempt at a monumental style of building is avoided, and the suitability of simplicity is acknowledged. How far the competitors have succeeded may be judged by the plans which we herewith publish, and in considering these designs it is desirable that the conditions issued for the guidance of the competitors should be kept in view:—

"A Bungalow for a Gentleman. The site for this small residence is on the side of a well-wooded hill a few miles from London, and the building is intended for summer occupation. The incline from east to west is 1ft. in 10ft., and the prospect, of course, is over the valley below. The approach is from the north. The base of the building is to be in red brick. The whole of the accommodation is to be on the ground floor, excepting a belvedere smoking-room, which is to be located over the central hall, out of which the reception and best bedrooms are to be approached. This hall is not to be treated as a sitting-room. The building must be compactly contrived in a simple and suitable way, remembering that a bungalow is not a baronial hall. The living-room is to be 24ft. long by about 18ft. wide. The drawing-room 16ft. by 13ft., or of that area. A billiard-room for a full-sized table. Four best bedrooms, and two more for female servants. A man's room is to be provided, and to be suitably isolated. A bathroom, lavatory and cloakroom, &c., and a box-room to be provided, and space for bicycles, golfing-irons, &c., is to be accommodated. There should be a small cellar, and the fall of the ground may suggest a half-basement; but the scheme is left to the competitors. Along the garden side of the house on the west front a terrace 12ft. wide is to be planned. The kitchen and offices to be appropriate for such a dwelling. Materials, brick and rough-cast. Tiled roofs. Scale, 8ft. to the inch. Style, suitability. Plans, two elevations, section, and view. If really necessary to work the drawings nicely into one sheet, the scale of plans may be 16ft. to the inch."

The designs chosen for the three first places are "Centaur," "Pantile," and "Hotspur," in this order of merit. The first design, essentially a bungalow, has an air of compactness about it, making for facility of simple roofing, and the belvedere balcony flat is a distinct advantage. The skylight trunk for the hall and belvedere stairway is a contrivance possibly necessitated by the central-hall arrangement, which we are aware

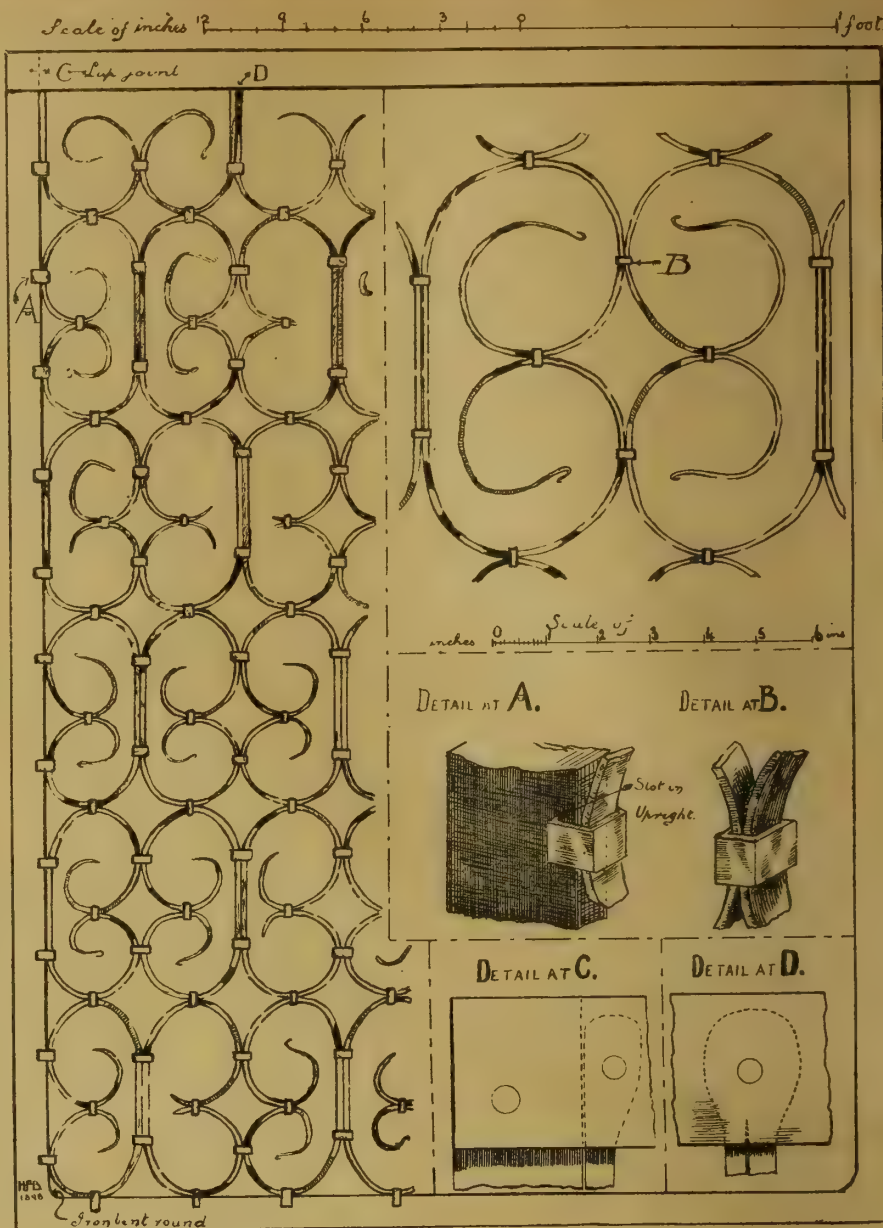

IRON GRILLE IN ST. ANSELM'S CHAPEL, CANTERBURY CATHEDRAL.

we asked for. There are objections, of course, to skylights of this kind, and "Centaur" has more than one of them, still, beyond a passing comment noting the contrivance, it appears hardly incumbent to say more on the point. One advantage of "Centaur's" plan is the manner in which the bedrooms and the servants' department are divided off from the living-rooms, and these latter are convenient and well placed. The plans show how the arrangement is managed. Of the exterior there is not much to say. The effect would have been improved if rather more had been made of the upper part of the bay to the dining-room, and the main entrance would have been all the better for a little more distinction. "Pantile" makes his bungalow on the "verandah" side too much like a village school, and the so-called "verandah" is really only a terrace. The plan is rather good, and is fairly well lighted. We do not quite like the dining-room service coming immediately past the front door, and an external door to the bicycle-house would have been an improvement. The drawing-room is not happily managed. The arched window to the dining room seems more suitable for a billiard-room, whereas the long low window to the billiard-room without the top-light would be inadequate. "Hotspur," the third design, is not economical, and his plan is scarcely a bungalow with its vestibule, lobbies, and corridors. Externally, the building is overweighted by the wasteful roof, though there is a degree of cleverness about the proposal which we have acknowledged. The w.c., provided in conjunction with the bedrooms, should be entirely isolated from

the billiard-room. In several details the plan is open to improvement. "Cædmon" has an ingenious plan, with the central hall placed diagonally in respect to the reception-rooms, the bedrooms forming a wing to the right of the entrance, and the kitchen and servants' room running to the left. Had the author worked out his scheme more carefully, and with a little more taste, he would have been awarded a higher place, for the general idea of the plan is a good one. Unfortunately, the passages are dark, and the design fails in detail, while in general effect the building is not a success.

"M'Gilligan" strives to be original and impart a freshness to his building. A symmetrical contrivance of circular bays to the dining-room and billiard-room on either side of the drawing-room on the garden front has seemingly governed the general arrangement of his scheme much too seriously, the smoking-room belvedere rising in between. The design is too cut-up, and although "M'Gilligan" has drawn it out carefully enough, his plan required a little more thought. For example, the verandah door from the dining-room looks directly into the best bedroom window. The hall would be very dark, and the wide passage opening out of it is very wasteful. "Petticoats" comes next with a better plan than elevation. The circular turrets would have been better omitted. The loss of space in passageways is a serious matter. There was no occasion to give the man's room a separate bath-room, w.c., and larder, and it is not a nice plan to locate the man's servants' bedrooms in the basement. "Umbopa" is not a good planner, dovetailing a bedroom in between the billiard-room and



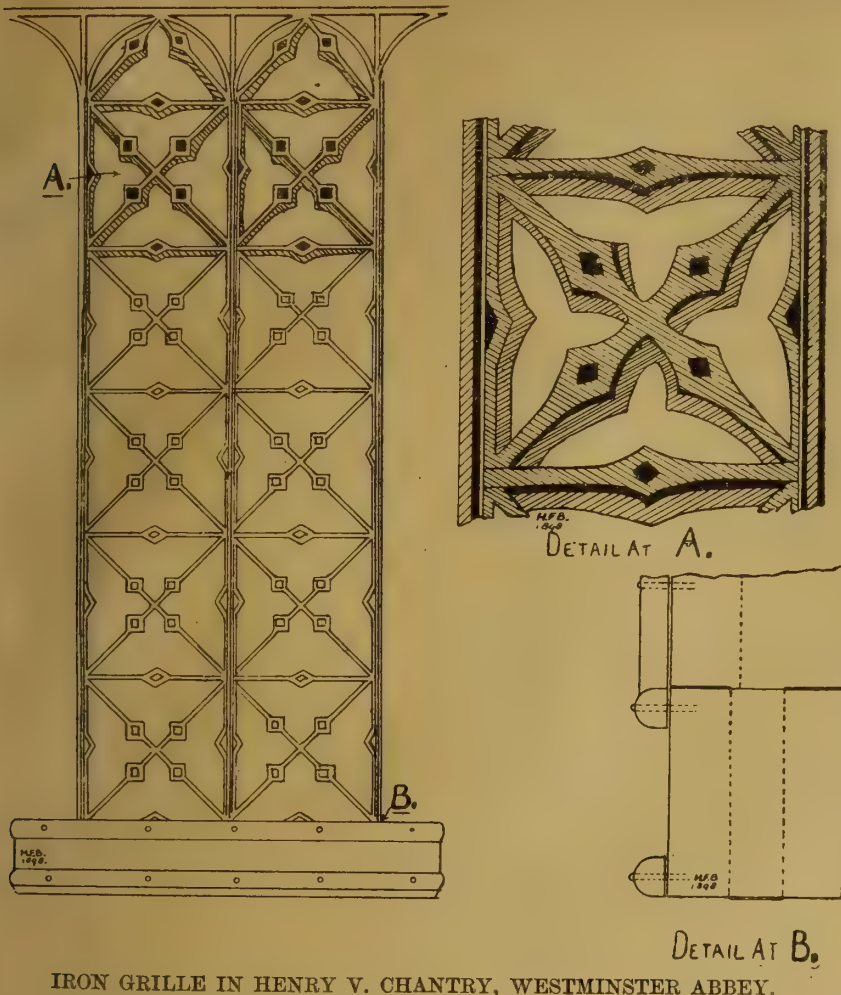

IRON GRILLE IN HENRY V. CHANTRY, WESTMINSTER ABBEY.

the drawing-room and locating another bed-chamber close to the front door. We have little to say in praise of this design, which in many respects is childish, but externally it exhibits some taste. The author would do well to cultivate this and learn to make a plan. "Zeo" is too dashing by half. His façade might be mistaken for a convalescent hospital, and his plan is made to fit the elevations regardless of convenience and comfort. The servants' bedrooms adjoin the billiard-room door, and close at hand is the bath-room, the chief bedchambers opening into the central hall. "Zeo" cannot expect to succeed if he mixes up his plan in this way. His chief idea seems to have been concentrated on the production of a very black-and-white perspective. For that much we place him here. "Microbe" sends a curious-looking building, mainly in timber, oddly schemed. The billiard-room is in the basement, and is very badly lighted. The kitchen and bedroom departments have the merit of being shut off from the rest of the house. A strange central tower serves as a belvedere. "Gib" is far neater, and in some ways far more successful. His plan is rather a good one; but in type the building is not a good one with all these internal walls and steps intended to accommodate the various levels. The belvedere is positively ugly, and the w.c. outside the door leading from the hall to the billiard-room is not nice. "Don't Know" is improving. He blots and spoils his work without much reason. In the plans sent for this bungalow he has more closely followed the scheme which we proposed than some more capable designers, and as we have spoken on previous occasions of his work somewhat sharply, we may, with good grace, commend his endeavour to do better. He has much room left to continue this development. "Angler" has sent no view. His design might look well. It is very simple, and in plan is L-shaped. The contrivance has its advantages; but the merits are mixed, and so are the sexes, for the man's room is close to the chambers for the maidservants—an arrangement which we specially provided against. "Glaour" makes a belvedere just like a photographic glass room. The brick arcade along the garden side would be very out of scale and most expensive.

His plan is compact rather, but strangely intermingled. Thus the washhouse is reached from a passage opening directly out of the hall. The kitchen is in the basement, and it is situate a considerable way from the dining-room. "Swan" has three corridors running side by side in the middle of his dwelling—an ungainly arrangement—with the idea of separating the parts of the house. A more curious scheme we have never seen. "Swan" should not repeat it. "B. C. P." does not give his design a chance, crowding up his drawings so. His plan is a clever one, and the elevations show no little ability. This house of his is not a bungalow in its external appearance, and it is drawn indifferently. "Rita" makes a timbered magpie house in his design, and locates his kitchen as far away as possible in his rambling plan from the dining-room, thereby increasing the difficulty of service with two series of steps in between the two apartments. Otherwise the plan is not a bad one, though the staircase leading to the smoking-room is needlessly important, with a big well to light the hall. "Derige" makes a village-school sort of building with a tower, for his bungalow, and roughcasts his walls with red-brick dressings—evincing taste it is true; but he rather misdirects his energy. The corridors and hall would be exceedingly dark, and so would the ingle-nook in the drawing-room. The perspective is drawn in a ghost-like way, without any structural lines. "Luna" has a strange composition in black and white timber, based on an oddly-shaped plan. The billiard-room has an apsidal end. The perspective strangely distorts the proportions of the scheme, and looks like a fragment from a willow-patterned plate. "Chess" concludes the series of designs by submitting a very unfinished scheme, the best part of which is the plan. The elevations are drawn in thin outline.

The Indian Government have sanctioned a loan of two lakhs of rupees to the Lahore Municipal Committee during 1898-99, and Mr. B. Parkes, executive engineer on special duty, has been engaged for some time on the plans and estimates for the new drainage and tramway schemes and the extension of the water supply.

## IRONWORK AT SOUTH KENSINGTON MUSEUM.—II.

By G. A. T. MIDDLETON.

II.—ENGLISH: IRON GRILLE IN ST. ANSELM'S CHAPEL, CANTERBURY.

THIS, like much of the English work in the Museum, is a reproduction, the original, dated 1333 A.D., being part of an existing grille in Canterbury Cathedral. It is typical of much contemporary work both in England and on the Continent, made of flat bar-iron in C curves, thinned out and twisted back at the terminals, and with strap and rivet connections, all entirely without foliage or stamped enrichment.

III.—ENGLISH: COPY OF GRILLE, HENRY V. CHANTRY, WESTMINSTER ABBEY.

Like the grille last illustrated, this is a copy, and is as typical of unenriched 15th as that of 14th-century work. It seems to have been made out of sheet metal, stamped and filed, a thicker sheet being superimposed over a thinner, giving somewhat the effect of moulded tracery, a method of working iron more common in Flanders than in England, and there applied mostly to small pieces of door and casket furniture.

## HEATING OF SWIMMING-BATHS.

WE so often receive inquiries as to the best mode of heating swimming-baths that we think architects will be glad to note the results obtained by Messrs. Messenger and Company, Limited's, improved system. The following report was made by Mr. Wm. Lord, superintendent of the public baths under the Corporation of the City of Coventry, April 28, 1898:—"I forward you inclosed the results of two tests of your heating apparatus as fixed to our three swimming-baths. No. 1 is taken with only 39,370 gallons of water in the bath, and this is raised to 76° before filling up. Test No. 2 is taken with 78,000 gallons of water in the bath. You will see by this that the steam jet is capable of raising 98,437 gallons of water 17° in 9½ hours with one boiler at work. Yesterday I filled the ladies' swimming-bath. We started the jet at seven o'clock, stopped one hour for breakfast, and raised the water from 52° to 76° by five o'clock—that is to say, 98,000 gallons of water were raised in temperature 24° in nine hours. This was with both boilers at about 40lb. pressure, and not condensing anything like as much steam as our steam spray used to do. Furthermore, a perfect circulation is obtained, as will be seen by the statistics I send you, which are taken all over the bath, both top and bottom. Since the apparatus was put in I have had no complaints about the differences in the temperature of the water. We were very busy on Saturday with slipper baths, and your apparatus and hot-tanks were put to a considerable test. I am very pleased to inform you that we made 686 slipper baths without having to call upon the old Calorifier for assistance. Your apparatus is a perfect success, and may be seen at work, if required, as a recommendation for your system."

## BOOKS RECEIVED.

*The Municipal and Sanitary Engineer's Handbook*, by H. PERRY BOULNOIS, M.Inst.C.E., City Engineer, Liverpool, &c. (London: E. and F. N. Spon, Ltd., Strand).—The third edition of this very useful handbook is before us, and has been revised and brought up to date. The legal references have been revised by Mr. J. B. Reignier Conder, the author of "Law Notes on the Surveyor." The contents and arrangement of the book appear to follow the lines of the first edition, and the Public Health Act (1875) and other Acts have been summarised. Chapters I. II. and III. treat on the office and law of the town surveyor, his appointment and qualifications, voluntary pass examinations, his duties, committee work, &c. Traffic, maintenance of streets, requirements of roadway, macadam roadways, road metal, rolling pitched pavements of stone, wood paving, asphalt roadways, curbing and channelling, lighting streets, &c., occupy several chapters. New streets and buildings, sewerage, sewage disposal, public conveniences, lighting, house drainage, pleasure grounds, artisans' dwellings, abattoirs, markets, cemeteries, contracts, &c., are also treated in detail. The handbook is especially valuable to all surveyors and students, and useful data and statistics are summarised. There is a good index.

—*Complete Perspective Course*, by J. HUMPHREY SPANTON, Gold Medallist of Royal Academy of Arts, &c. (London: Macmillan and Co., Ltd.), comprises the elementary and advanced stages of perspective, the projection of shadow and reflections, &c., and the practical application of perspective, and is intended for candidates for the examination of the Science and Art Department, South Kensington, &c. The author has dealt with the subject in a thoroughly complete manner. The problem exercises are admirably suited for the requirements of the examinations referred to, and every case is considered. We should have liked to have seen more practical applications of the problems; the chapter on perspective for architects and engineers at the end of the volume is inadequate to meet their requirements, and we think too much space has been given up to what we may term the academical problems and examples. The diagrams are clear and well engraved; but the objects or examples chosen are confined too much to the conventional school of art models instead of to architectural and practical examples. Such solids as pedestals, columns, bases, towers and spires, cupolas, arcades and interiors, and furniture would have furnished excellent examples of application. The remarks on photographic perspective are useful, and serve to show how an exaggerated perspective of a photograph may be corrected in making a drawing from it.—*Industrial Electricity* (translated and adapted from the French of HENRY DE GRAFFIGNY, and edited by A. G. ELLIOTT, C.Sc. (London: Whittaker and Co., White Hart-street, Paternoster-square), is one of the first of the proposed volumes of Whittaker's "Electro-Mechanical" series. This volume explains in non-mathematical language the many useful applications of electricity. The French original has been extensively sold. The book is intended as an introduction to the series, and each chapter explains briefly and popularly a distinct branch of practical electricity. The other volumes will enter more into detail.

—*A Guide to the City Guildhall* (Simpkin, Marshall, Hamilton, Kent, and Co.) Mr. John J. Baddeley, Chairman of the City Lands Committee, has written an excellent guide to the Guildhall, containing a brief but picturesquely-treated historical sketch of the Corporation, and an account of the work carried on by the Court of Common Council. The compilation is profusely illustrated from photographs, and, better still, has on the back page a plan of the labyrinth of buildings—library, art gallery, police and mayor's courts, council chamber, committee rooms, and offices—surrounding the Guildhall. The little book is published in paper covers at 6d. net.

#### THE COLLAPSE OF THE ROOF OF ABBEY MANSIONS, WESTMINSTER.

AS we briefly mentioned last week, Mr. Troutbeck, assisted by Mr. John Slater as assessor, resumed on Thursday, the 12th inst., the inquest on the seven men killed by the fall of the south section of Abbey Mansions, Victoria and Orchard streets, Westminster. The accident took place on April 21, and in our issue of the following day a double-page illustration of the building was given. James Andrews, the general foreman of the works, who was under examination when the Court adjourned on the previous day, was further questioned by the Coroner with reference to the construction of the pier. He said the footings for the pier were seven courses of brickwork in extent, and 4ft. 1½in. wide at the bottom. According to the terms of the Building Act, footings should be twice the thickness of the wall. He believed the footings were put in for a thicker wall. Mr. W. R. Rickard, the principal contractor, recalled, produced an agreement entered into between himself and Mrs. Leeds, of West Norwood, on November 12 last, under which Mrs. Leeds purchased the freehold and indemnified the witness "from any further personal cost in respect of the completion of the building." Mr. Young, solicitor to Mrs. Leeds, said the short effect of the document was that Mrs. Leeds bought for £1,000 all Rickard's interest in the north and south blocks, and subsequently to that she became the freeholder. The document which had been put in was intended to appoint Rickard as her contractor. Mr. Avory said the document must be read with the building agreement of June 23, 1896, which was in possession of the mortgagee's solicitor. Mr. Young said that by that agreement it was Rickard's venture, and by the subsequent con-

tract he parted with his interest to Mrs. Leeds for £1,000. The witness Rickard said that since Nov. 12, 1897, he had acted as contractor for Mrs. Leeds to erect the building. Certain materials intended for the building were consigned to Mrs. Leeds because that lady's credit was better than his, and in some cases he was authorised to pledge Mrs. Leeds's credit. The cost of the bricks which were condemned was £2 2s. per 1,000 alongside, which was a good price. They were condemned by Mr. Pawley, the architect, at another job. Mr. Pawley told witness that those bricks were rather soft, and ought not to be used for the bottom part of the building. The best of the bricks might have been used for the inside walls. Mr. Avory: When Mr. Pawley condemned these bricks at the other job, did you not lead him to understand that they would be ground up for mortar?—Quite so, or most of them. I do not think they were all bad. Mr. Avory: But all those he condemned you gave him to understand would be ground up for mortar?—Yes. The witness, in reply to further questions, said Mrs. Leeds was the widow of a builder, by whom witness had for many years been employed as building contractor. Mr. Pawley acted merely as architect, and witness paid his fees. Mr. C. W. Courtenay, the contractor for the stonework, gave evidence of supplying stone templates, five of which were of a larger size than the others. Mr. Tom Drew-Bear, engineer, of Queen Victoria-street, said his firm, Drew-Bear, Perks, and Co., supplied some of the girders for the building. He prepared a scheme for the ironwork construction, but it was not carried out, and the girders were supplied according to order. In the plan no provision was made for stanchions. Mr. Samuel Murrell, engineer, Victoria-street, S.W., said he was the contractor for the cast-iron cornice, and he was asked by Mr. Simpson, on behalf of Mrs. Leeds, to concrete the roof, which he had already made. After doing that he started the concreting. The centring and concreting were to be paid for at the rate of 3s. per yard. He did not see any specification as to how the concrete was to be mixed, and he had no instructions. He provided the coke breeze, but the cement and the lifting were found for him. The work of concreting the roof was commenced on March 25. On Wednesday, April 13, the roof had been concreted, with the exception of a portion round the skylight. Later on, there was some discussion with reference to an alteration of the skylight, and eventually some of the concrete was cut away by the order of Andrews, the foreman. By April 16 the whole of the concreting had been finished. None of his men did anything on the roof up till the dinner-hour on the day of the accident. Witness lunched with Mr. Simpson, the assistant architect, on that day, and Mr. Simpson's last words were: "Don't, on any account, let any of your men strike that centring." Witness thereupon told his foreman, the deceased man Parker, through the telephone, not to touch the centring, but to get on with the sixth-floor joists. A little later he heard of the calamity, and on going to the building he found that the centring had been struck. With regard to the alleged improper mixing of the concrete, that material would speak for itself. The cement was given to him by Simpson, and it caused no loss to him no matter how much was used. Assuming that the building collapsed owing to the removal of the centring the concrete would fall in pieces of 3ft. 6in. wide. He could give no reason for the joists falling. His belief was that the accident was caused by someone hoisting a weight by means of a winch and a "snatch" fixed around the pier, so causing the pier to "shoot out." By Mr. Kent: It was dangerous to strike the centring at the time it was struck. John Hammond, a labourer who was at work on the roof at the time of the accident, said he and five other men were instructed by the deceased man Parker to strike the centring. The concrete was very hard, and to test it witness "bounced" a crowbar on it. It sounded like a drum. He was certain that the concrete did not go first. The whole thing collapsed without the slightest warning. He should say the concrete was thoroughly set and fit for striking. He could not say whether there was any hoisting going on at the time. He did not notice any vibration. He saw nothing to account for the collapse. He had known concrete to set well and the centring to be fit for striking in eight days. The portion of the concrete which collapsed had been up a much longer time. At the opening of Monday's proceedings Mr.

Horace Avery, counsel for Mr. C. J. C. Pawley, the architect, made a statement with reference to Mr. Pawley's position so far as the property was concerned. The governors of the Grey Coat Hospital were the freeholders, and Mrs. Leeds acquired a building agreement from them with the option of purchasing the land. Mrs. Leeds acquired the freehold, and the deed included a declaration of trust in favour of Mr. Pawley, who was a *cestuique trust*. Then a building agreement was granted to Mr. Rickard, and he subsequently sold it back to Mrs. Leeds for a sum of £1,000. Mrs. Leeds was, in fact, only Mr. Pawley's trustee. It was in the legal position of beneficial owner that he agreed with H.M. Commissioners of Works to grant them a lease of these two blocks when they were completed. Mr. Kent: After November 12 Rickard was working under the direction of Pawley at prime cost. John Peckham, a carpenter in the employment of Messrs. Jas. Smith and Son, of Norwood Junction, the contractors for the joinery work, said he was on the roof of the building at the time of the accident, working at the skylight, which had a deal frame and oak sashes. There were three poles from 4in. to 5in. in diameter properly lashed across the opening, forming a jib. A few minutes before the accident he noticed that there was a great strain on the jib and the block was "squeaking." Something was evidently being raised, but he did not know what. He noticed the breeze concrete cracking. There were two or three distinct cracks parallel with the front wall. He warned his mate that the roof was collapsing, and they both ran to the parapet and jumped on. When they looked round they found that the concrete, iron girders, and everything else had disappeared. He agreed with all that the witness Hammond had stated, except that he was of opinion the concrete round the north skylight was moist. By Mr. Avory: In his opinion the striking of the centring had something to do with the falling of the roof. The concrete appeared to be hard in places, but he considered that it had not been laid long enough for the centring to be struck. By Mr. Ellis Griffith: He had all that day known that the concrete was soft at the spot he had indicated. Thomas Copping, carpenter, who was also at work on the roof at the time of the accident, gave corroborative evidence. When warned by the last witness that the roof was falling, he hurried away to the parapet, and on his way he felt the roof rising slightly. The moment he got on the parapet the whole roof collapsed. The concrete around the frame of the north light was rather soft. The workmen were hoisting by the jib on the centre light right up to the time of the accident. He should say that the scaffold poles forming the jib would carry about a ton. By Mr. Avory: Mr. Murrell did not suggest to him that the hoisting caused the collapse. By Mr. Gardiner: It occurred to him that the striking of the centring was improper, but he did not tell the foreman so. Leonard Skinner, a labourer employed by Banks's Fireproof Syndicate, Ltd., said he never found any of the binding girders tied with ropes. The girders were all fixed and bolted together in the ordinary and proper way. The lacing joists did not bolt. Charles Smith, a labourer in the employment of Mr. Murrell, the roof contractor, said he was one of the men injured in the accident. He was working at the time on a scaffold immediately under the roof, and was drawing the bolts, when suddenly, without warning, the entire roof collapsed. He could not account for the collapse. The concrete appeared to be all right. The boards came clean away. Thomas Stewart, a foreman plumber, said he was employed on the building. On the day of the accident he was on the roof of the south block. He heard a cracking sound like the crushing of a matchbox, and he scrambled to a scaffold. The roof collapsed altogether. The witness, in reply to the coroner, said there were no scaffold poles across the centre skylight for hoisting purposes. The coroner pointed out that that was a distinct contradiction of what other witnesses had sworn to. The witness adhered to his statement, adding that the jib referred to was erected after the collapse. Before the accident the opening of the centre skylight was occupied by the scaffold on which the deceased man Bray was working. There must have been a snatch block, but he did not see it. If there was a jib formed of scaffold poles it must have been below the scaffold under the roof. Henry Alfred Penfold, a scaffolder, said

he was on the sixth floor striking the scaffolding when he saw the hoist go to the front, and everything fell from the roof on to the sixth floor, and thence to the basement. He believed that the poles forming the jib were erected by the contractors for the stonework. At the adjournment the coroner released Mr. Young from further attendance on behalf of Mrs. Leeds.

On Tuesday, William Aspinall, a stonemason in the employment of the Victoria Stone Company, said that at the time of the accident he was on the staircase between the sixth and seventh floors, and the first thing he noticed was the pier falling over towards him. He had no doubt whatever that the pier collapsed first and that the roof followed it. He and his mates hoisted material with the aid of a snatch block attached to a scaffold pole passed through one of the back windows. It was in no way connected with the brick pier, so that any strain which was caused would not affect the pier. The weights raised varied from 2cwt. to 4cwt. William Aspinall, sen., father of the last witness, gave corroborative evidence. Immediately afterwards it collapsed with a crash, and the roof fell in. Frederick George Gander, a scaffolder, employed on the sixth floor of the building at the time of the accident, said he noticed dust flying up above the pier, and immediately afterwards the pier buckled up about the level of the sixth floor. He came to the conclusion that the buckling up was the result of too great a weight being placed on the top of it. The pier stood without support, except that there were iron joists in it, and there was nothing in the middle to steady it. Charles Albert Gander, a labourer, brother of the last witness, corroborated. Edward John Thorp, a bricklayer, said he had a contract with Mr. Rickard for labour only on the brickwork at £4 a rod without scaffolding, and £6 a rod with. He did the whole of the brickwork of the south block. He received instructions from Rickard's general foreman, Andrews, at whose office he saw the plans. The footings were put in for a 2ft. 8in. wall; but the wall was reduced from off the top of the footings to 18in. The pier was built up to the level of the fifth floor five bricks by two-and-a-half bricks thick. From the fifth floor to the roof he reduced the dimensions to 3ft. 9in. by 1ft. 10in. He altered it after a conversation with Andrews, who agreed with him that the pier would be stronger built that way. Three girders ran from each floor to the pier. There were six large templates in the pier, and hard stock bricks and cement were used in its construction—not mortar, as was stated by Collins. He did not know where the bricks came from; but no soft bricks were used in the construction of the pier. It was not true that part of the pier was erected on a template. He attributed the collapse to the fact that the concrete was not properly set, so that when the centring was removed a sheet of concrete between the lacing joists, about 23ft. in length, caved in against the top of the pier, which was the weakest point, and pushed the pier over. By Mr. Avory: On April 18 the concrete generally was soft; he broke it with his fingers. He saw the concrete half an hour before the accident, and he did not think it was in a fit state for the centring to be struck. Concrete of that thickness should be laid at least 21 days to be thoroughly reliable. It was untrue that soft bricks, unfit for use, were used inside the building. He never saw a job better supplied with bricks. By Mr. Ellis Griffith: There might have been 10,000 or 12,000 bricks used. His opinion was asked on each barge load. He complained about the quality of the bricks, and was always told not to use any which he considered unfit for use. By Mr. Kent: All the brickwork in the pier was absolutely sound and good. Harry Sage, foreman scaffolder, described the accident.

On Wednesday Peter White, a man in the employment of the brick contractor, described the collapse of the roof, which he attributed to the centring being struck too soon. He did not agree with previous witnesses that the whole mass came down together. The concrete roof broke in the middle of the lacing joists and left the girders about 10ft. from the pier. He afterwards examined the concrete and found some of it was hard and some very soft. Henry James Homer, another of Mr. Thorp's employes, said the pier was constructed of hard stock bricks and cement. They sometimes made up to the binding girders with cement instead of using a small template. They used some soft bricks in the wall, and Mr. Thorp stopped them at it. He

saw nothing but cement used. By Mr. Thomson: He had been at work a fortnight when he and his mates were instructed by Mr. Thorp not to use soft bricks. Not more than 1,000 soft bricks were used in the construction of the wall. He was positive there were not three templates on each floor, as Andrews, the general foreman, had stated, nor were the templates made level with pieces of slate. Elwin George Thorp, son of the brick sub-contractor, said his father informed him just before the crash that Murrell's men were striking the centring too soon. By Mr. Avory: The pier came down in pieces from 3ft. to 4ft. square. The coroner remarked that that showed pretty conclusively what was the character of the brickwork. James Morris, sub-contractor for paint work, spoke to seeing the roof crash through the various floors, the girders in their descent tearing away the brickwork. Thomas Roberts, the foreman carpenter in charge of the joinery work for Messrs. James Smith and Son, the sub-contractors, said the collapse of the building happened in 12 seconds. Mr. Edward Dru Drury, the district surveyor, said he received notice of the proposed erection of Abbey Mansions in March, 1896. He considered the plans and wrote the result of his inspection on August 21. A question had arisen as to whether the building was to be used for domestic purposes, which would have necessitated the reservation of an open space in the rear. That accounted for the delay. He wrote to Mr. Pawley, the architect, pointing out the requirements of the Building Act. It was finally settled by the Building Act Committee of the London County Council. Amended plans were afterwards shown to him by Andrews, and witness found they complied with the terms of the Act. He saw no detail plans. He had no powers with regard to the brick pier. If he considered a pier to be dangerous he could only report it to the London County Council after it was built. He would have control only over cross, external, or party walls. The Building Act said nothing about brick piers. He last visited the building on March 16, when he found that it exceeded the limit allowed by the Act in the height of the front wall in Orchard-street. He called Mr. Rickard's attention to the irregularity, and Rickard wrote on March 25 informing witness that the building was vested in her Majesty's Government, and was therefore, under section 202, exempted from the provisions of the London Building Act. Witness had no control over girders unless they carried a wall. Girders leading to a pier would have nothing to do with him. If a story was constructed in a roof with the floor more than 63ft. above the street it must be built entirely of fireproof materials. The roof of this building did not come particularly under his notice. The brickwork was very good, and the pier was made of stock bricks and cement. It was quite impossible for 1,000 soft bricks to have been used without witness or his assistant seeing them. Section 146 of the Act defined his duties. He could not call attention to a dangerous building until it was erected. After the collapse he procured a sample of the concrete, and found that it was wet, but he did not think that it had been badly mixed. The moisture would add materially to its weight. He saw no concrete that could be crumbled with the hand. If the girders had remained steady and in the place, he did not think the concrete would have fallen. He was of opinion that the pier was carrying two tons more than a safe load, which he calculated would be about 45 tons. The draft lease to which the witness had referred was put in. The coroner said it included an agreement entered into on November 19, 1897, between Mr. Pawley, "hereinafter called the landlord," on the one side, and her Majesty's Commissioners of Works on the other, whereby Mr. Pawley agreed to let the south block of Abbey Mansions on a lease for 21 years from December 25, 1897, "or so soon thereafter as the building shall, in the opinion of the surveyor of her Majesty's Office of Works, be fit for occupation." Mr. Avory said the building was made higher to suit the Government. The coroner expressed the opinion that, as the building had not been finished, it had never been in the occupation of the Government, and therefore was not exempt from the terms of the Building Act. Mr. Fraser said that Mr. Drury could not seek to enforce the Act without coming into collision with H.M. Commissioners of Works. The Coroner said it was a very nice point. Mr. Drury, whom he did not blame, evidently thought the building was exempt, and ceased his super-

vision of the building after a certain date. Mr. Drury said he had two theories as to the cause of the disaster. The first was that the centring was struck too soon, and that the concrete fell in consequence and levered the pier over; but that theory had been demolished since he had been in Court. He was of opinion that the pier broke because it was not thick enough. The inquiry was adjourned until to-day (Friday).

#### CHIPS.

The reconstructed Jamaica Bridge at Glasgow will be completed early in 1899. It will be of granite in seven spans, three of the arches being of Cornish granite, and the other four of material from Aberdeen and Fifeshire. The contract is being carried out by Messrs. Morrison and Mason, of Glasgow.

A synagogue is in course of erection from plans by Mr. William Whiddington, of Queen-street, Cheapside, in Fieldgate-street, Whitechapel.

A new board school, Classic in style and three stories in height, is being built in Albion and Hanover streets, Aberdeen. Mr. Arthur Clyne, of Union-street, Aberdeen, is the architect. Accommodation will be provided for 1,000 children.

The scheme for the erection of a Protestant Cathedral for Belfast has advanced a further stage, as to the small nucleus of a building fund a sum of £7,000 appears likely to accrue under the will of the widow of the eighth Earl of Shaftesbury, who died a fortnight ago. By her will, the Countess of Shaftesbury has bequeathed to her trustees the sum of £7,000 free of duty, upon trust, that if at the date of her death, or within five years thereafter, a Protestant cathedral should be erected, or in course of erection in Belfast, to apply the same and any accumulations of income resulting therefrom in or towards the cost of such erection.

It is officially announced that the Queen has appointed the Earl of Ideseleigh, Sir Richard Thorne Thorne, Major General Constantine P. Carey, Mr. Charles P. Cotton, Professor Michael Foster, Colonel Thomas W. Harding, Mr. Thomas W. Killick, Professor W. Ramsay, and Dr. James B. Russell to be a commission to inquire into and report upon the treatment and disposal of sewage. Mr. F. J. Willis is appointed secretary to the commission.

The Scarborough Corporation have resolved to acquire additional property, to the amount of £6,000, for the purposes of the Harcourt-place improvement. This includes Granby House and adjoining property, and the corporation are entering into negotiations for further purchases.

The organ in St. Barnabas' Church, Tunbridge Wells, is about to be enlarged, and placed in a raised position in the organ chamber, at a cost of about £700. The work will be carried out by Messrs. Lewis and Co., of Brixton, who built the instrument.

At Terenure a new Roman Catholic Church, dedicated to St. Joseph, is in course of erection from designs by Mr. W. H. Byrne, of Suffolk-street, Dublin. The building is Romanesque in style. It consists of nave 46ft. by 30ft., with north and south aisles 14ft. wide, chancel and sanctuary 70ft. in length and 30ft. wide, side chapels and transepts, and a tower and spire rising to a height of 160ft. The architects are Messrs. Michael Meade and Sons, of Great Brunswick-street, Dublin.

The Local Government Board have sanctioned a loan to the Tring Urban District Council of £5,000 for sewerage and sewage-disposal works.

A two manorial organ, partly built by the late Mr. Joseph Hopkinson, of Birstall, and completed by Mr. Andrews, of Bradford, has been erected in the Congregational Chapel, Drighlington, at a cost of about £235.

At Middleton Parish Church, Lancashire, of which the late Bishop Darnford was the rector from 1835 up to 1870, when he was called to preside over the Episcopal See of Chichester, the parishioners have, in memory of him, carried out the restoration of the Langley screen (of the Rector's Chapel) and the Rood screen, while in continuation of these a new screen has been erected across the Assheton Chapel in order to commemorate the record reign. The total cost of the work is about £500. Special commemoration services were held last week.

The cemetery committee of the Islington Vestry has accepted the tender of Messrs. Gough and Co., builders, Hendon, for the erection of the chapel for the Nonconformist portion of the cemetery for £3,054.

The restoration of the tower of St. Leonard's Church, Milton, has just been completed. The work has cost £1,400, of which Earl Fitzwilliam, who is lay rector, has contributed £600, besides inserting, at his sole cost, a chiming clock, worth an additional £500, in memory of her Majesty's Jubilee.

## OBITUARY.

A PAINFULLY sudden death occurred in Birmingham on Monday morning, Mr. JOHN BLAND, who had for years been in practice at 14, Temple-street, as an architect, being suddenly taken ill in his office, where he died. Mr. Bland, who is said to have been unwell on Sunday, had for some years enjoyed a very extensive practice, and under his direction most of the large carpet factories in Kidderminster, as well as several churches and schools about the Midlands, were erected.

Mr. CHARLES COCHRANE, of the Woodside Ironworks, Stourbridge, and of Middlesbrough, died on Wednesday in last week at his residence, Green Royde, Pedmore, near Stourbridge. He was the eldest son of the late Mr. A. B. Cochrane, of the Woodside Ironworks, who did so much to advance the prestige of the South Staffordshire iron industry. It was from the Woodside Works that came the ironwork of the great Exhibition of 1851, which was re-utilised in the Crystal Palace. Westminster Bridge Cannon-street Railway Station, Charing Cross Railway Station, and Charing Cross Bridge are also among well-known engineering works of the firm, and the Clifton Suspension Bridge is one which Messrs. Cochrane and Co. removed from Hungerford Market, Charing Cross, and re-erected after strengthening it. The Woodside Works, which had been built by Messrs. Cochrane and Bramah in 1841, became exclusively Mr. A. B. Cochrane's in 1853, when Mr. Bramah retired. Mr. A. B. Cochrane died in 1863. The Woodside Works had since belonged to the late Mr. Charles Cochrane and his brother, Mr. J. B. Cochrane; but, besides this, they were greatly interested in the works of Messrs. Cochrane and Co. in Middlesbrough, which was managed by Mr. Charles Cochrane. He had served as Mayor of Dudley, and was on the rolls of Dudley, Worcestershire, and Staffordshire justices. In politics Mr. Cochrane was an ardent Liberal, and he threw himself *con amore* into the election contests at Dudley. He had been one of the mainstays of the Dudley Geological and Scientific Society, to which he recently presented his private collection of fossils.

At a meeting of Volunteers, held at Huddersfield on Monday, it was decided to take steps for the erection of Volunteer headquarters and drill-hall. Subscriptions exceeding £1,990 were announced in the room.

Operations have been commenced this week in the demolition of the Bedford Hall, near Clapham-road railway station, preparatory to the erection of a station on the site in connection with the extension of the City and South London (Electric) Railway from Stockwell to Clapham Common. This will be an intermediate station, and premises at the corner of the High-street and Acre-lans have been acquired and cleared for the building at that point of a terminus.

An extension of some importance is about to be made to the parish church of St. John, Hammer-smith, which was erected from the designs of Mr. Wm. Butterfield some years since. The architect now employed is Mr. J. F. Bentley, who is building the Roman Catholic Cathedral at Westminster. The addition to St. John's comprises a morning chapel. The new organ, of which the same architect designed the case, has lately been finished.

The European Commission of the Danube have unanimously decided to commence the execution of a cutting five miles long, 400ft. wide, and 20ft. deep, which, together with former cuttings, will convert the Sulina branch of the river five years hence into an almost straight waterway, 35 miles in length, extending from the port of Sulina to the Tultcha branch of the main river. On the 8th inst. King Charles conferred the Grand Cordon of the Crown of Roumania on Sir Charles Hartley, who has been the engineer-in-chief and consulting engineer of the Commission from its creation till the present time. Since 1872 a member of the Institution of Civil Engineers, Mr. C. Kuhl, has been resident engineer.

The will of the late James O'Byrne, architect, of Liverpool and Birkdale, who died in January last, has been proved in Liverpool. The gross value of the estate has been sworn at £107,335 14s. 3d., and legacies are left to executors, relatives, friends, and servants to the amount of £8,400. Books, curios, plate, articles of vertu, and furniture, of the value of £20,000, the deceased bequeathed to the Roman Catholic Seminary at Upholland, near Wigan, of which building he was the architect. All the real estate, which is valued at £60,000, has been left to Bishop Whiteside, of Liverpool, absolutely. The collection of coins and medals and rare old china is said to be unique in this country.

## COMPETITIONS.

BERWICK-ON-TWEED.—An open competition has been held for a new police-court and lock-up to be erected by the Berwick Corporation in Church-street. Thirty-seven designs were sent in, and, after being submitted to the assessor, Mr. J. Crosier, county architect for Durham, have been exhibited in the Rector's Room at the Corporation Academy. Mr. Crosier's report stated that five drawings had been selected by him, as under:—No. 14, estimated cost, £4,945; No. 34, £4,987; No. 35, £3,453; No. 9, £4,900; No. 27, £5,000. These were found when the envelopes were opened to be the numbers of the following architects:—1, R. Burns Dick, 55, Northumberland-street, Newcastle-on-Tyne; 2, Charles Frederick Short, 98, Blenheim-crescent, London, W.; 3, Stephen Piper, 52, Westgate-road, Newcastle-on-Tyne; 4, Fetch and Triggs, 20, John-street, Adelphi, London, W.; 5, Charles T. Marshall, 4, Northumberland-street, Newcastle-on-Tyne. The buildings will consist on the ground floor of a police-station with seven cells and a house for resident constable; and, on the upper floor, of police-court, with magistrates', witness's, and other rooms. The limit of cost is about £5,000.

ROMFORD.—The urban district council of Romford, having decided to erect public swimming-baths in Mawney's-road, Romford, invited designs from architects for the same, and have selected for execution the design submitted by Messrs. Harrington and Ley, of 108, Fenchurch-street, E.C.

WOLVERHAMPTON.—The documents with regard to the competition for designs and plans for the new workhouse at New Cross, Wednesfield, have been issued by the workhouse committee of the Wolverhampton Board of Guardians. It has been decided not to have an open competition for the appointment of an architect, but that the competition shall be limited to three architects, to be selected by the guardians, who are recommended to choose Messrs. Mangall and Littlewoods, of Manchester, Mr. W. Doubleday, of Birmingham, and Messrs. Marshall and Turner, of Nottingham, to compete, on the terms that the author or authors of the designs and plans selected by the guardians have the appointment of architect at the usual fee of 5 per cent. upon the outlay authorised by the guardians, to include all fees and extras, and that each of the other two competing architects be paid a sum of £100 for their fees and expenses. The accommodation required at the workhouse will include a test-house, with wards for sixty able-bodied men, together with labour-yard and shed for stone-breaking; wards for 350 men, not sick or insane, but partially able-bodied and old, to include a separate day-room, with separate sleeping cubicles in it, partitioned off about 7ft. high, for fifty deserving men; workshops for woodchopping, tailor, shoemaker, carpenter, blacksmith, tinner, matmaking, and oakum-pickers; sheds for carpet-cleaners and for storing wood and oakum—these to be connected with the above wards and the labour yard. Wards for 80 able-bodied women, also for 130 women not sick or insane, but partially able-bodied and old, with separate day-room and sleeping cubicles for 30 deserving women, similar to old men's; separate day-room, with separate cubicles, for 20 married couples, and a separate sewing-room. Infirmary wards for 160 males, 120 females, &c.; and infectious and contagious wards for 20 males and 20 females, with accommodation for two nurses attached; insane wards for 60 males and 60 females, and wards for 30 male and 30 female epileptics. Casual wards for 50 males, on the separate-cell system, and one general room, to provide for an excessive number of males; and for 20 females, consisting of one general ward and six separate cells; lodge and separate entrance for casuals, with rooms for tramp master and his wife; storerooms, kitchen; dining-hall to serve as chapel; laundry, mortuary, disinfecting-room; rooms for officers; offices, nurses' home, master's house; boardroom for guardians' meetings, committee rooms, waiting, bath, and other rooms, &c. The designs are to be delivered by the 1st July next.

At a meeting of the Smethwick Technical Education Board, held on Monday evening, it was decided to invite six local architects to prepare plans for a technical school, and to offer two premiums. It is proposed to build schools in Crockett's-lane at a suggested expenditure of about £5,000.

## Engineering Notes.

HASTINGS.—The report of Sir Douglas Fox, who made an examination of the work at Hastings Harbour, has just been issued to members of the town council. He considers the site well selected, but is of opinion that the foundations are of insufficient depth to be left unprotected on the seaward side. Commenting upon this, Mr. A. E. Carey, the engineer-in-chief, says that in his judgment the weight on the foundations is perfectly safe and proper. The local defects discovered, he adds, were not serious, and the contractors were responsible for their repair. Sir Douglas Fox's report proceeds to refer to the danger of scour, and suggests modifications as regards the foundations of the parapet. Other suggestions advised an improved method of continuing the arm and an increase in the thickness of the parapet. Sir Douglas was of opinion that the revised estimate of £226,532 would cover the cost of the works. Mr. Carey thinks that Sir Douglas Fox's schemes for the prevention of scour and with regard to the thickness of the parapet are impracticable, and that the design of the breakwater has been justified by the results.

THE NEW BRIDGE AT NIAGARA.—The second great steel arch bridge which is being built across the gorge at Niagara Falls to take the place of the last of the suspension bridges is to be the largest of its kind in the world. The main arch was completed on April 18. The new bridge is to stand on the site of the upper suspension bridge close to the Falls, and will practically connect the two great free parks at Niagara, the New York State reservation on the one side, and Queen Victoria Niagara Falls Park on the other. The length of the main span is 868ft., and of the flanking spans, the one on the New York State side to be 190ft. long, and the one on the Canadian side to be 210ft. long, making a total length of 1,268ft., which is the length of the bridge it is to supplant. The arch is to be a single deck structure, and its floor will have a width of 49ft. Of this 23ft. in the centre will be given up to a double track for an electric road service across the gorge. On each side of the track there will be carriageways 8ft. wide, and beyond them still there will be footpaths for pedestrians slightly elevated above the roadways. In all, 4,000,000lb. of steel will be used in its construction. It is expected that the structure will be finished by early summer. The arch will be the fourth bridge erected on this site, the first having been thrown open to the public in 1869. It was a wooden bridge, 10ft. wide, and in 1887-88 it was rebuilt in steel and given a width of 17ft. This bridge was destroyed by a hurricane in January, 1889. It was at once rebuilt, and it is this bridge that is now to give way to the new one. When the arch has been completed, the suspension bridge that it supersedes is to be transferred piece by piece seven miles down the river to the site of the old suspension bridge connecting Lewiston, N.Y., and Queenston, Ont., and there rebuilt to take the place of the bridge destroyed by a wind storm in 1864. The chief engineer in charge of the whole work is Mr. L. L. Buck.

## CHIPS.

The Admiralty has sanctioned an expenditure of about £15,000, to extend a building slip at Devonport Dockyard.

The Midland Railway Company's bold scheme for a new Lancashire harbour at Heysham is making good progress. The tender of Messrs. Price and Wills, of Westminster, has been accepted at £490,000 for the construction of two breakwaters a mile and a half in length respectively, and a pier 2,000ft. in length. The harbour will have a water area of 46 acres.

A Greater Malvern has just been created, the amalgamation of the local authorities representing Great Malvern, Little Malvern, Malvern Link, and Malvern Wells having been completed after much negotiation. Henceforth the Malverns, which now have a population of 16,000, an area of 4,300 acres, and a rateable value of £102,000, will be ruled by an urban district council.

The Brighton Recreation Grounds Committee have received a letter from Mr. T. Howard offering to present the corporation with the toll-houses of the old Chain Pier for erection in one of the public pleasure grounds of the borough. It was resolved that the offer be accepted, and that the toll-houses be utilised as park constables' shelters.

## Building Intelligence.

**BIRMINGHAM.**—The Norwich Union Fire and Life Assurance Societies have formally entered into possession of the building at the corner of Congreve-street and Edmund-street, which was erected for the Birmingham Liberal Club, and which will now serve as the company's head office for the Midlands. The red-brick and terracotta structure cost, with the site, something like £70,000, and was erected in 1884. Shortly after the "split," the building was sold, and the club took up much humbler quarters. The price realised was less than half the original cost. A short time ago the Norwich Office purchased the building for £40,000, and placed it in the hands of the original architects, Messrs. Cossins, Peacock, and Bewley, and the original builders, Messrs. W. and J. Webb, for adaptation to commercial purposes. The ground floor contains the public department of the office. A new Gothic doorway, with stone mouldings in the style of the other arched work of the exterior, has been constructed in Congreve-street. The Fire Department on the left of this entrance, and with a frontage to Edmund-street, has been formed out of the old reading-room of the club, the inner partition wall having been arcaded, and a counter placed along the line of arches. The Life Department occupies what was formerly the entrance-hall and lounge. The office furniture (by Chamberlain, King, and Jones) is of oak, of a design to harmonise with the architecture. The large dining-room has been divided by oak-and-glass screens; but the height of these has been restricted so as to sacrifice as little as possible of the effect of the fine proportions of the room and of the ceiling and other decorative features. Strong-rooms and store-rooms have been constructed in the basement, and the upper rooms have been fitted up as offices.

**BRISTOL.**—The Fairfield-road Higher Grade Board School and School of Science is in course of erection. The range of buildings has been erected on a three-cornered site on the sloping side of a hill, the mixed school, science school, and infants' school being grouped in triangle fashion, so as to leave a small playground in the centre and larger playgrounds in two of the angles of the land. The external masonry is of Pennant laid in erratic courses, and relieved by red-brick window and door openings, and terracotta decorations. The mixed school has a central hall, 62ft. by 30ft., on the ground floor, and a similar apartment on the floor above, the upper room being loftier, and having an open timber roof. Round these rooms are grouped 10 class-rooms, each 25ft. square, and there are also teachers' rooms, store-room, dining-room, and cloak-rooms. The science school contains a chemical laboratory, a physical laboratory, apparatus-room, lecture-room, drawing-room, &c. The drop in the ground enabled a workshop, 44ft. by 21ft. 6in., to be placed beneath the science floor, and also a cookery-room. The infants' school has a central hall 50ft. by 24ft., with four classrooms and a teachers' room opening from it. The floors throughout are laid with wooden blocks, and firegrates are used in addition to the hot-water pipes. The schools and corridors have a high dado of brown glazed bricks, and above the walls are plastered. The architect is Mr. W. L. Bernard, F.R.I.B.A., and the contractor is Mr. John Perkins, of Redland. The school, which is intended to accommodate 1,054 pupils, will cost £18,142 in addition to £5,110 given for the site.

**BURY, LANCs.**—The building of new stables for the co-operative society in Knowsley-street, Bury, Lancs, has been recently commenced. The designs, which have been prepared by Mr. T. Nuttall, architect, Market-street, Bury, show that the new buildings are in the Renaissance style of the period of William III. The dressings of the front of the building are in stone from the Morley quarries, Leeds, the main body of the wall being of Ruabon 2in. bricks. The stables are fitted up with Musgrave's (Belfast and Manchester) stable fittings, accommodation being provided for 20 horses, besides sick-room accommodation. The woodwork of the interior is of pitch-pine. The stables are lighted from the top with Heyward Brothers and Eckstein's patent lights. The floor of the stable and the covered way is laid on a bed of concrete, the flooring being of patent grooved brick. The buildings are heated on the hot-water low-pressure system.

The contract has been let to Messrs. Thompson and Brierley for between £3,000 and £4,000, and the ventilating and heating arrangements and the electric light fittings are being carried out by Messrs. J. H. Pickup and Co.

**CANTERBURY.**—The latest work accomplished in the restoration of the cathedral is the decoration of the screen at the back of the altar, dividing the choir from the Trinity Chapel. Hitherto this has consisted of plain stone and glass, relieved by no ornamentation whatever. The seven centre panels, forming the retables, are now illustrated with angels, each carrying emblems of the passion. The predominant colours in the stone canopy are gold and red. The whole of the work has been carried out under the superintendence of Mr. Fisher, on behalf of the firm of Messrs. A. O. Hemmings and Co., St. Margaret's-street, London, W.

**EAST SUSSEX ASYLUM.**—At the last meeting of the East Sussex County Council, the report was received from the visiting committee for providing a new asylum, asking the council to authorise them to purchase the greater part of the Hellingly Park Farm and part of the Park Wood, containing altogether about 400 acres, as a site for the proposed new asylum, for the sum of £16,000, the timber and underwood and tenant right to be paid for by valuation. The committee also asked the council for a grant of £103 10s. 11d. expenses incurred, with a further sum of £1,000 to meet current expenses. In a further report the committee stated that they had appointed Mr. George T. Hine, of 35, Parliament-street, S.W., to be their architect. The committee had succeeded in finding an abundant supply of water on the proposed site at Hellingly at a depth of 176ft. from the surface, which had risen to the bottom of the shaft a height of more than 100ft., but they had not had time to obtain an analysis. The committee had decided to call the new asylum the Amberstone Asylum, if built on the proposed site at Hellingly. The report was adopted with the exception of the last paragraph. Considerable opposition was offered to the proposal to entitle the building Amberstone Asylum, and by 24 votes to 17 it was decided to call it simply the "East Sussex Asylum."

**HULL.**—The foundation-stone of a new Congregational Church in Prince's-avenue was laid on the 5th inst. The church will be cruciform on plan, having a nave 32ft. long and 28ft. wide, with north and south transepts 18ft. 6in. and 15ft. 6in. in depth respectively, and 23ft. 6in. in width; there are north and south aisles 8ft. 6in. in width separated from the nave by an arcade, having polished granite shafts, with moulded stone bases and caps, the arches being in moulded bricks. The transepts are lighted with mullioned windows, having cusped heads and moulded transoms, the aisle windows being similar, but without transoms. There is a clerestory with mullioned and traceried windows on either side of the nave. The church will seat 585 persons on the ground floor, and 68 in the gallery. The choir is provided for behind the pulpit, and in the rear of the church are the minister's vestry, church parlour, stores, kitchen, and lavatories. The buildings are designed in the Late Gothic style. At the north-west angle of the nave is a tower square at its base, but working out into an octagon, the upper stage of which is pierced by eight gabled openings, surmounted by a moulded and carved tabling, from which rises a stone spire. The west front is flanked by octagonal terminations. The principal frontages are faced with red stock bricks, the dressing to the doors and windows being in Ancaster stone. The roof of the church is in Memel fir, open-timbered up to the level of the collar beam, having mullioned and cusped spandrels, and the ceiling is of a pentagonal form. The whole of the internal walls will be plastered, the arches being in moulded red bricks. The seats throughout are open benches, having sloping backs and seats, and solid cut ends. The choir-stalls have panelled and chamfered open framing in front, with moulded capping and cornice. The pulpit and the whole of the seating will be in pitch-pine varnished. Adjoining the church, and communicating therewith, are the school premises, consisting of a large room 50ft. by 28ft., two classrooms, and an infants' classroom 22ft. by 17ft. The cost of the work is about £4,300. The architect is Mr. W. H. Bingley, Custom House Buildings, Whitefriargate, Hull.

**KING'S HEATH.**—The opening services of the new Baptist church at King's Heath took place last week. It is built partly on the site of the

old chapel. It is 72ft. long by 43ft. wide, has transepts and a large chancel, and will accommodate about 500 persons. The materials used are Leicestershire bricks, with Hollington stone for the dressings and the mullions of the windows. Internally the church has an open timber roof of pitch pine, springing from stone moulded corbels, constructed with bold arched ribs. The floor is on an inclined plane, and the seating is so arranged between the nave piers that every member of the congregation can have an unobstructed view of the minister. Vestries are provided for the minister, deacons, and the choir, and there is also a ladies' room. The church is heated by hot-water pipes, and is ventilated on the automatic principle of Tobin flues in the walls, and exhaust roof ventilators. At the rear is the school erected some time ago. The work has been carried out by Messrs. James Moffat and Sons, of South-road, Camp Hill, from the designs and under the superintendence of the architect, Mr. A. Harrison, of Queen Chambers, Colmore Row, Birmingham. The cost has been £7,000.

**LYNTON.**—The foundation-stones of a town-hall, which Sir George Newnes is presenting to the inhabitants of Lynton and Lynmouth, were laid last week. The hall will occupy a site abutting on Lee-road, with Hollerday, the residence of Sir George Newnes, overlooking it from the high ground above. The hall was designed by Messrs. Reed and Macdonald, of London. The style is Early Elizabethan. It is built of local shallemway stone, with Ham Hill stone dressings. It has a half-timbered front with stone mullioned windows, and red tiled roof. A sundial is to be placed in the main gable over the porch entrance. There will be a library and recreation-rooms, with separate entrances, council-room, surveyor's office, clerk's ditto, and entrance-hall. The main staircase, which will be panelled with oak, has its first flight 12ft. wide, afterwards dividing into two sections, and leading to the main hall on the first floor, which will be oak-panelled also. The main hall, 72ft. by 34ft., will seat 435 persons, and will have an open-timbered roof, with platform arranged for concerts and theatricals, and specially-constructed floor on springs for balls, &c. It is provided with six exits from the main hall, so as to be emptied in three minutes in case of fire.

**MANCHESTER.**—The new Christie Library which is being added to Owens College is approaching completion. It is being built from designs by the college architects, Messrs. Alfred Waterhouse and Son, Mr. H. Vickers, of Nottingham, being the builder. It is situate to the east of the present college buildings, adjoining Burlington-street, and in close proximity to the Whitworth Hall, also now in course of erection. In style it conforms to the lines followed by the architect in his earlier instalments of the college, although in this case Derbyshire stone is used for facings. The building, measuring 100ft. long by 46ft. wide, is 46ft. high to parapet, and to the ridge of roof 73ft. Space is thus found for three stories. The ground floor, intersected by corridors, is partitioned into seven rooms, all (corridors as well as rooms) to be lined with books. A staircase leads to the first floor, the whole of which is occupied by one apartment, 97ft. by 40ft., and over 20ft. in height, divided down its length by a double range of stone columns into three aisles. Two bays at the north end, set aside to contain the library of the donor, will be cut off from the rest of the room by an oak screen. Including this section, there are in all seven bays, each of which is lighted by windows in pairs 13ft. high, and divided by detached shafts of Derbyshire stone. The plaster ceiling is treated in alternate bays with geometric patterns, the remainder being left plain. The second floor, although entirely in the roof and intended for storage purposes, has a height from floor to apex of 31ft. From end to end runs a central passage 10ft. wide and 22ft. high to the crown of the timber arches of the principals. The room is divided into bays corresponding to those below, and is lighted by two-light dormer windows, piercing the three gables on each side of the room, and, further, by wooden dormers. At each end of the room is placed a window group of five lights. On the north and south elevations is a large blank wall space flanking the three-light windows of the lower floors, decorated only by the arms of the college and those of the donor of the building in panels. At the corners octagonal projections contain the staircases con-

ducting to the light galleries which give access to the higher ranges of the library shelves. The library will be connected with the Whitworth Hall by a corridor conducting to the ground floor, while on the other side a graceful arch supporting a bridge corridor will connect it with the main buildings of the college. The building is heated by hot air introduced in the sills of the windows, and the fittings will be of oak. We illustrated the library in our issue of May 8, 1896.

**NUNEATON.**—The Birmingham and Midland Counties' Bank, in the Market-place, Nuneaton, was opened last week for business. Messrs. Wood and Kendrick, of West Bromwich, are the architects, and Mr. Councillor Thomas Smith, of Nuneaton, is the contractor. The treatment is Renaissance, a feature of the work being the terracotta adornments. The fittings are of mahogany, and have been executed by Messrs. Bennett Bros., Birmingham, the floor of marb'e mosaic, and the exterior, materials used are Heather bricks and buff terracotta. The banking-room is entered at the corner; the room is 42ft. by 36ft. The bank, in addition to fireplaces, will be heated by hot-water radiators. The manager's house has a private entrance from Coventry-street, and has three reception-rooms, six bedrooms, and the kitchen and other accommodation.

**TAUNTON.**—New almshouses have just been built in St. James'-street, in the place of old dilapidated almshouses on the opposite side of the street. The architect is Mr. J. H. Spencer, of Hammet-street, Taunton, and the contractor Mr. T. H. Moggridge, of Queen-street, Taunton. They are two stories high, and are built of red Bridgwater brick, with some Bath stone dressings, the roofs being covered with dun colour tiles. Accommodation is provided for six married or twelve single persons, as the case may be, a living-room, bedroom, and scullery being provided for each couple. There are three porches, arranged so that each porch serves as the approach for two sets of rooms. The living-rooms and the bedrooms above are 12ft. by 10ft. in size. The total cost has been about £1,200.

A public hall is about to be built at Newark-on-Trent at a cost of £3,000, from plans by Messrs. Sheppard and Harrison, of that town.

A private meeting of the quarry owners of North Wales has been held at Chester to consider what action should be taken in regard to insurance in view of the Employers' Liability Act, which comes into operation at the end of June. Mr. Nicholson, of Porth-y-Waen Quarries, near Oswestry, was voted to the chair, and the owners present represented wages amounting to £40,000 per annum. The policy was discussed of united action in regard to insurances, but eventually the meeting was adjourned for further inquiries to be made.

The committee for raising a memorial to the late Duchess of Teck have accepted the offer of an anonymous donor to erect and furnish a home of rest for poor working women of London, on the south coast, where, during the year (allowing each occupant a fortnight at a time) some 130 women can be received. With a view to economical management it is intended that the building shall be erected immediately adjoining the Victoria Convalescent Home for Women at Bognor, on a site and in a building provided by the same munificent donor. £11,000 (of which £9,000 has already been subscribed) will be needed for permanent endowment and maintenance.

The London and South-Western Railway Co. are about to carry out an extensive scheme of widening between Vauxhall and Clapham Junction. The narrow and low bridges over the Falcon-road, Latchmere-road, New-road, Stewart's-road, and Queen's-road are being replaced by new girder bridges 40ft. in width, and two additional lines of railway will be provided. Messrs. Perry and Co., of Tredegar Works, Bow, are carrying out the foundations and brickwork, and the girder work for bridges is by the Patent Shaft and Axletree Co., of Wednesbury.

A bank with offices above is about to be built in Dewsbury from plans by Mr. John Lane Fox, architect, of that town. It will occupy the corner of Northgate and New Bridge-street, with doors at the junction of the two thoroughfares, the frontage to the first being 36ft., and to the second 67ft. The height to cornices will be 47ft., and from thence rise lofty roofs with windowed gables. The elevation of the first floor will be of grey polished granite, and that above ashlar from the Holmfirth quarries, relieved with granite bands. The roofs will be covered with green Westmoreland slates, and have a ridge of red tiles. A room for the manager is provided *en suite*, with a strong-room, and there are ten offices on the floor above.

### PROFESSIONAL AND TRADE SOCIETIES.

**THE AUCTIONEERS' INSTITUTE.**—The annual general meeting of the members of the Auctioneers' Institute of the United Kingdom was held at the institute, 57 and 58, Chancery-lane, on Friday afternoon, Mr. J. F. Field, the president, in the chair. In moving the adoption of the report, the president said the past year had been an eminently satisfactory one for the institute. The new members elected numbered 130, and at the end of the year there were 861 members. The income for the year was £1,627, and the expenditure £1,287, and there was a balance to the credit of revenue of £375. The increasing number of entries for the examinations of the institute and the excellence of the work done was very gratifying. The renewed agitation for the amendment of the law of distress had occupied the attention of the council, who received a deputation of bailiffs on the matter. They were now awaiting the representations of those particularly interested in the subject to enable them to arrive at some decision as to what reforms were needed. He expressed the hope that in the near future the institute would be under the protection of a Royal Charter and would be housed in more suitable premises. The report was adopted.—In the evening the 12th annual dinner of the institute was held at the Hotel Cecil. The chair was again taken by the president. After the loyal and patriotic toasts, Mr. Alderman Buckell (Oxford) proposed "The Imperial Parliament," and Mr. Rentoul and Mr. D'Arcy Wyvill responded. The toast of "The Legal Profession," proposed by Mr. D. T. Alexander, was acknowledged by Sir H. B. Poland and Mr. W. A. Blaxland. Sir Walter Wilkin proposed "The Auctioneers' Institute of the United Kingdom," and the president, in reply, remarked that the object of the institute was to raise the status of the profession by the elimination from it of unworthy members. Other toasts followed.

**BURY BUILDING TRADES' FEDERATION.**—The sixth annual meeting of this federation was held at the Stanley Arms, Bury, Lancs, on Wednesday in last week, the chair being occupied by the President, Mr. E. Wild, of the Joiners' Society. The report of the past year's work and the balance sheet were read and adopted. On the motion of Mr. D. Riley, seconded by Mr. J. Rollinson, Mr. Stanley Hall (plumbers) was elected president, Mr. Walter Park (plumbers) was elected as vice-president, Mr. Walter Harper (stonemasons) was re-elected as secretary, and Mr. J. Rollinson (painters) was re-elected as treasurer. It was decided, after discussion, that the meetings be held quarterly instead of monthly, as at present, the secretary to call special meetings between the quarterly meetings if necessity arose.

**LIVERPOOL ARCHITECTURAL SOCIETY.**—The annual meeting of this society was held on Monday evening in the new offices of the Law Library, Cook-street, Mr. W. E. Willink (president) in the chair. The annual report, read by Professor F. M. Simpson (honorary secretary), stated that the present membership was 131, compared with 121 last year. The council was pleased to state that the increase in the number of members attending the meetings referred to in last year's report had been fully maintained, and it was hoped that more of the younger members might be induced to read papers and join in the discussions. The report, as well as the financial statement, read by Mr. Dod, were passed. There is a balance in hand of £25 in favour of the society's funds, and of £42 in regard to the library account. The following officers were then re-elected:—President, Mr. W. E. Willink, M.A.; vice-presidents, Mr. W. Owen and Mr. J. Woolfall; joint secretaries, Professor F. M. Simpson and Mr. Arnold Thornely; honorary treasurer, Mr. James Dod; and honorary librarian, Mr. J. W. Blakey. The new council consisted of the following:—Fellows, Messrs. C. J. Anderson, H. L. Beckwith, J. W. Blakey, T. E. Eccles, Henry Hartley, William Owen, J. Woolfall; associates, Messrs. F. E. P. Edwards and E. P. Hinde.

**NATIONAL ASSOCIATION OF SLATE MERCHANTS AND SLATERS.**—The half-yearly conference of this association was held last week at Furness Abbey Hotel. The President (Mr. W. E. Thompson, Dewsbury), in his presidential address, referred to the efforts made by a sub-committee to bring about an arrangement between the large quarry owners in Wales and elsewhere in the mutual advantage of all. Foreign competition

was now keenly felt by the trade, and last year the importation of slates from America alone was shown to have been of the value of £200,000. The annual report showed that the membership now stood at 423. Various papers were read. It was determined that the next conference should be held at Bradford.

### CHIPS.

New schools are being erected at Cefn Coed, and special consideration has been given to the ventilation, which will be carried out on the Boyle system.

The Union Infirmary, Glossop, is being warmed and ventilated by means of Shorland's patent Manchester stoves with descending smoke flues and Shorland's patent Manchester grates, the same being supplied by Messrs. E. H. Shorland and Brother, of Manchester.

New offices for the stipendiary magistrate in Moorland-road, Burslem, were formally opened on Monday by the Earl of Dartmouth, lord lieutenant of the county. They have been built from the plans of the late Mr. E. Penn, at a cost of £1,200, exclusive of land and fittings, the contractor being Mr. J. J. Longden.

A report has been made to the Brighton Works Committee from the borough engineer, recommending that the Madeira-road be widened at the narrowest part by the building of a new concrete wall to the south from Camelford-street groyne to the Chain Pier toll-house. Also, that the new timber breastwork, now stopped at Rock-place groyne, be continued westward to meet the new wall. The cost is estimated at £1,750. The committee consider the work necessary.

Princess Christian formally opened the new residence for the clerical and lay workers of the Eton College Mission in Marlborough-road, Hackney Wick. The new building is an imposing edifice in red brick, built at a cost of £4,500, and contains accommodation for nine residents.

A fire broke out on Wednesday at the Union Works, Church-street, Deptford, belonging to Messrs. H. E. Holloway, builders. The fire, which started in a structure two floors high full of combustible material, spread rapidly to the four large buildings used as workshops, engine and boiler-houses, stores, &c. Another fire occurred on Wednesday at 1, Pitt-street, Bethnal-green, E., upon the premises of Mr. A. Copas, builder, and the shop and its contents were almost entirely destroyed.

The Queen has intimated to the East Cowes District Council her willingness to open the new road which has been constructed by her Majesty between the town and Whippingham.

The tramway committee of Glasgow Corporation agreed on Tuesday to increase the salary of Mr. Clark, the engineer, by £50 per annum, and that of Mr. Young, the manager, by £256 per annum, making the salary of the latter £1,500 a year.

At a meeting of the museum and school of art committee of Birmingham corporation, held on Monday, Mr. W. H. Bidlake, M.A., A.R.I.B.A., Waterloo-row, Birmingham, special lecturer on architectural history and architectural design at the Central School of Art, was appointed architect of the new branch school of art in Moseley-road.

The new chapel built in connection with Mill Hill School, from designs by Mr. Basil Champneys, will be formally opened on the 22nd of next month.

Poppyhead stalls for clergy and choir and a bishop's throne have just been placed in the small and ancient cathedral of Clonfert. The work is all in carved oak, and has been executed by Messrs. Sharp and Emery, of Great Brunswick-street, Dublin, from designs by Mr. J. J. Fuller, F.S.A., of that city.

The annual payment of £100 to the British School of Archaeology at Athens was voted on Tuesday by Oxford Congregation for another three years.

The City and Brixton Railway Bill, which has already been sanctioned by the House of Commons, has been referred to the Unopposed Bill Committee of the House of Lords, owing to the withdrawal of the threatened opposition. By this Bill a new company will be incorporated, with a share and loan capital of £1,600,000, for the purpose of constructing an electric railway from Brixton-hill to a junction with the City and South London Railway at a point under the High-street, Borough.

The corporation of Liverpool have at the present time under consideration the expenditure of about £40,000 on the building of three distinct fire stations, in addition to its central establishment; this is arranged on the most modern lines, and it possesses a chemical fire engine, the advantage of which is that in fires of small dimensions it is more effective than the ordinary water engine, while it serves to avoid the deluging of burning premises with water, which in many instances does more harm than the fire itself.

CONTENTS.

Hurry in Building ... 695  
 Pictures at the Royal Academy ... 695  
 Model Specifications.—XIII. ... 697  
 Royal Institute of British Architects ... 698  
 The Surveyors' Institution ... 699  
 BUILDING NEWS Designing Club ... 700  
 Ironwork at South Kensington Museum.—II. ... 701  
 Heating of Swimming-Baths ... 701  
 Books Received ... 701  
 The Collapse of the Roof of Abbey Mansions, Westminster ... 702  
 Obituary ... 704  
 Competitions ... 704  
 Engineering Notes ... 704  
 Building Intelligence ... 705  
 Professional and Trade Societies ... 706  
 THE BUILDING NEWS DIRECTORY ... IX.  
 Our Illustrations ... 707  
 Archaeological ... 707  
 Correspondence ... 726  
 Intercommunication ... 727  
 Legal Intelligence ... 731  
 Water Supply and Sanitary Matters ... 732  
 Parliamentary Notes ... 732  
 Statutes, Memorials, &c. ... 732  
 Our Office Table ... 732  
 Meetings for the Ensuing Week ... 732  
 Trade News ... 730  
 Latest Prices ... 730  
 List of Competitions Open ... 731  
 List of Tenders Open ... 731  
 Tenders ... 733

ILLUSTRATIONS.

- ST. PATRICK'S CHURCH AND PRESBYTERY, DUNDEE.—  
 HIGHER GRADE SCHOOL, SCARBOROUGH.—PASSMORE  
 EDWARDS HOLIDAY HOME FOR CHILDREN, CLACTON.—  
 CAPITAL AND COUNTIES BANK, YEOVIL.—DESIGNS FOR  
 HILLSIDE BUNGALOW.—MAISON DE RAPPORT, PARIS.

Our Illustrations.

ST. PATRICK'S CHURCH AND PRESBYTERY, DUNDEE.

The drawing which we give to-day is from the Royal Academy. The church is seated for 800, while the presbytery contains accommodation for three priests—viz., dining-room, three sitting-rooms, parlour, waiting-room, four bedrooms, and kitchen premises, &c. The buildings occupy a prominent site. Externally, the walls are finished in two shades of red stone, the hewn work being from Dumfriesshire, while the natural-faced squared rubble is from Berrymuirhead. The roof is covered with green slates, finished with a red tile ridge. Internally, the floors of the aisles, confessionals, baptistery, and mortuary chapels are tiled, while the sanctuary and space round altars is laid with parquet flooring. The total cost will be about £9,000. The architect is Mr. T. Matin Cappon, Dundee.

HIGHER GRADE SCHOOL, SCARBOROUGH.

The accompanying drawing is in this year's Royal Academy Exhibition. The design was selected in competition early last year. Thirty-six sets of designs were sent in, and the premiums were awarded by the assessor, Mr. E. R. Robson, as follows:—1st, Messrs. Hall, Cooper, and Davis, Scarborough, and 21, Old Queen-street, Westminster; 2nd, Messrs. Demaine and Brierly, York; 3rd, Messrs. Marshall and Dick, Newcastle. The building is constructed of red pressed bricks, with Whitby stone dressings, and roofed with red Ruabon tiles. The architects have endeavoured to combine good proportion in outline and detail with careful treatment in free Renaissance. There are two fronts, that facing Westwood-road on the north being somewhat severe, whilst the south front entirely differs, in the respect that the central block forms an excellent façade with a series of stone columns, heavy dentilled stone cornice, and large sculptured frieze, illustrating "Mathematics," "Letters," "Music," "Crafts," "Chemistry," "Art," &c. The whole of the sculpture has been done by Mr. Henry Fehr. The contractors for the work are as follows:—Brick and stonework, James Bates and Sons; carpenter and joiner, George Seales; plaster, Hugh Proctor; iron and smith's work, Harry Pickup; plumber, Tindall and Williams; painter, Thomas Fidler; tiler, Joseph Hardgraves; fireproof floors, Homan and Rogers, Manchester.

THE PASSMORE EDWARDS HOLIDAY HOME FOR CHILDREN, CLACTON-ON-SEA.

The site is a very fine one, fronting the Marine Parade, in area 1½ acres. The building will accommodate nearly 100 children, and is planned so that the dining and play-rooms face the sea. The administrative portion is in one block,

comprising kitchen, scullery, larder, &c. The matron's room is on one side of the main entrance, with library and elder girls' sitting-room, boot, and cloak-rooms adjacent. Separate entrances are provided for boys and girls, and staircases to their dormitories; but they use the living-rooms in common. All the dormitories face the sea, and are arranged for eight and ten children in a room. Bath-rooms are provided on each floor, and clothes locker. Provision is made for future extensions. All the w.c.'s are outside the building. Red bricks and tiles for roofs are to be used. The architect is Mr Charles Bell, F.R.I.B.A., 3, Salters' Hall-court, Cannon-street, E.C.; and Messrs. Hammond and Son, Romford, are the builders. The contract price is £6,596.

CAPITAL AND COUNTIES BANK, YEOVIL.

The erection of this building is now being proceeded with. The site is a peculiar one, and one of the most important in the town, at the junction of High-street and Princes-street. The building is of Ham stone, and consists of the bank itself on the ground-floor with strong-room in basement. The upper floors are devoted to a manager's residence. The desks, partitions, and fittings of the bank are of oak. Fireproof floors and partitions are to be used, and the bank is to be heated by hot water. Messrs. Bartlett and Son, of Yeovil, are the contractors. The architect is Mr. J. Nicholson Johnston, A.R.I.B.A.

"BUILDING NEWS" DESIGNING CLUB: A HILLSIDE BUNGALOW.

For description and awards see page 700.

MAISON DE RAPPORT, PARIS.

The plans which we give of the Maison de Rapport, No. 71, Boulevard Ornano, Paris, are from the designs of Mr. Charles Blanche, an architect who has had no inconsiderable experience in the erection of buildings of this class. In London, and in many of our larger cities, dwellings, or, as some prefer to call them, mansions in flats, are being erected in some districts on a very large scale. At Hampstead, for example, just now row upon row of residential flats are furnishing the speculating builder with much work, and many an opportunity for the display of ingenious planning, as well as vulgar architecture. A few architects have embarked in speculations of this class themselves, and syndicates are starting other similar undertakings. Shops on the ground-floor frequently have to be provided where there is a chance of good rentals being obtained, and, in most cases, the several floors are repeats of those below. The accompanying illustration has been chosen as an example of planning from Paris where, although in some not unimportant details the French builders differ from English ideas of comfort and sanitary contrivance, some extremely skilful arrangements are to be observed, for our Continental cousins have been for many years a long way in advance of British notions in the matter of residences contrived with a common staircase and common roof. The rather odd shape of the site which Mr. Charles Blanche has so ingeniously built upon, no doubt rendered the architect's task more difficult, while the nature of this building of smaller lodgings made it undesirable to provide the very usual carriage drive into the courtyard. There are, however, two passage-way entries with staircases adjoining, and beyond the courtyard other entrances and staircases are provided. These plans, which we reproduce, are in many ways instructive, and those of our readers who do not subscribe to the *Moniteur des Architectes* will be glad to have a copy by them of these plans for reference. Externally, strict economy had to be observed, the bay oriels being the only features used to diversify the plainness of the façade. There are six floors above the ground-floor. The materials used are brick and stone.

A new county cricket-ground adjoining the West Park, Hull, was recently opened. The playing area is an almost complete circle, 170 yards in diameter, with a specially prepared portion 60 yards long by 30 yards wide, for wickets. This has been dug out 2ft., drained, arched, filled in with 18in. of fine loam soil upon 6in. of clinkers, and turfed with sods from the Argyle-street ground. The mean level of the ground is taken for setting out the wickets, and in carrying out the work over 1,500 loads of soil, &c., were carted in for levelling, and some 15,000ft. of drain-pipes were laid, all having an outfall into the manholes. Mr. Percy T. Runtun was the architect.

ARCHÆOLOGICAL.

SOUTHAMPTON.—An important discovery has been made by Messrs. Cooksey and Glasspool at Southampton, in connection with the slum demolition. It is that of an ancient vault adjoining the western end of the Undercroft, in Simnel-street. The doorway, now bricked up, at the west end of the Undercroft, leads into the cellar of the adjoining house. The front cellar, opening on to Simnel-street, is of Norman work, and is constructed of stone, well squared and laid. To all appearance, the front was at one time quite open to the street, as the walls are bevelled or chamfered towards Simnel-street. This chamber was some 20ft. deep, the back part of it being of rougher work, but in the front is still to be seen what is described as a Norman cupboard of fine Caen stone, about 2ft. by 2ft. 6in. It is now filled up with rubble and broken lumps of plaster. At the back of this chamber are four corbel tables of Norman character, which carry the struts of the timber floor above. There is also a smaller corbel which carries nothing. The floor above is supported by huge timbers, one said to be of chestnut, and the other with more probability identified as of oak, which appears to be contemporary with the building itself. Some of these timbers having become dangerous, two brick stone piers have been erected, on which are laid transverse beams, which themselves bear evidence of having formed part of an ecclesiastical or important domestic building, the beams being finely moulded with a moulding of the later Early English character. At the rear of this chamber is an archway of Transitional Norman work with a plain chamfer and no capitals, forming a depressed two-centred arch, wide in proportion to its height, which leads into a long Norman barrel vault, some 30ft. by 10ft. At the spring of the arch, on both sides, for the entire length, is a wall-plate or strong course of Norman design. The masonry is rough, with the exception of the strong course. At the furthest end of the vault, the usual ventilating shaft has been plastered up at some period. The back wall is so roughly joined to the vaulting that it looks rather as if the vault had been longer, but had been walled up at some, now very distant, date.

CHIPS.

The urban district council of Cleethorpes have raised the salary of their surveyor, Mr. Egbert Rushton, to £210 per annum.

The magistrates of Arbroath have resolved to fix Saturday, 4th June, for the formal opening of the Free Public Library which has been gifted to the town by Mr. David Corsar, of The Elms.

The urban district council of Bognor have received the sanction of the Local Government Board to borrow the sum of £2,000 for the construction of a sea-wall and esplanade.

The urban district council of Wallasey have decided to purchase the Earliston estate at Liscard, containing a house and about 20 acres of land, from the trustees of the late Anthony Smith, for the sum of £20,000, for the purpose of extending the cemetery.

A monument has been erected in the Jesmond Old Cemetery to the memory of the late Mr. Wm. Laws, builder and contractor, of Heaton-on-Tyne. It stands 19ft. high, on a base of freestone, and is of Rutiglian grey granite, all polished. Upon three base steps stands the die containing the inscription, carrying in turn the cap, supported by four marble columns, the caps and base being granite. On each side are granite pedestals, on which stand the figures of Hope and sympathy, executed in Sicilian marble. Over the capital is a canopy of polished granite, which will cover a portrait bust of the late Mr. Laws, executed in statuary marble, the whole being finished with a draped urn. The memorial has been designed and executed by Mr. B. Donaldson, Red Barns, Newcastle.

The construction of the White Pass and Yukon Railway is being actively pushed on by a large staff of engineers and labourers. The line which is being built will cover the distance from Skagway Harbour to Lake Bennett, and thence to Fort Selkirk. The first section, from Skagway to Lake Bennett, will be open for traffic by September next.

The Convocation of Oxford have authorised the curators of the University chest to expend £7,500 in removing and reconstructing the iron laboratory at the University Museum, at present occupied by the Linacre Professor of Comparative Anatomy, and in erecting on its site a new laboratory and lecture-room for the joint use of the Sherardian Professor of Botany and the Linacre Professor of Comparative Anatomy.

B. N. D. C. DESIGN FOR A

BUNGALOW BY  
MOTOR

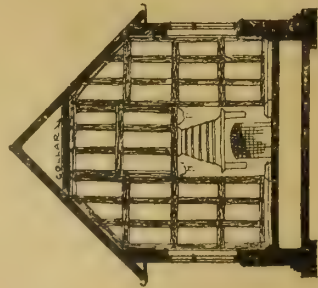

SECTION ON BB



BASEMENT PLAN

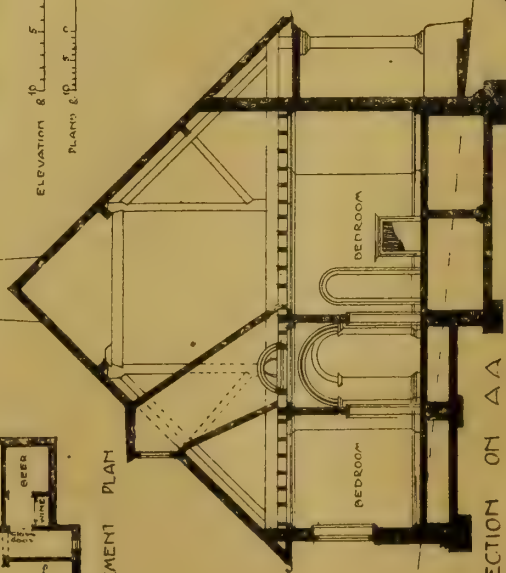

SECTION ON AA



BLOCK PLAN



GROUND PLAN

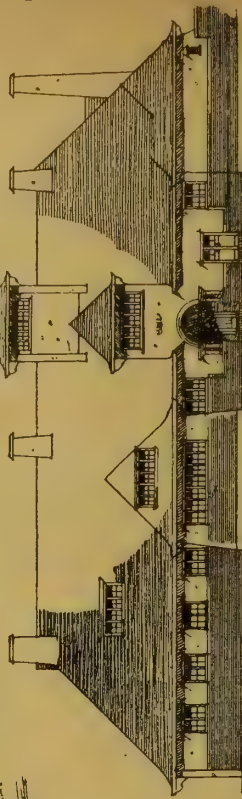
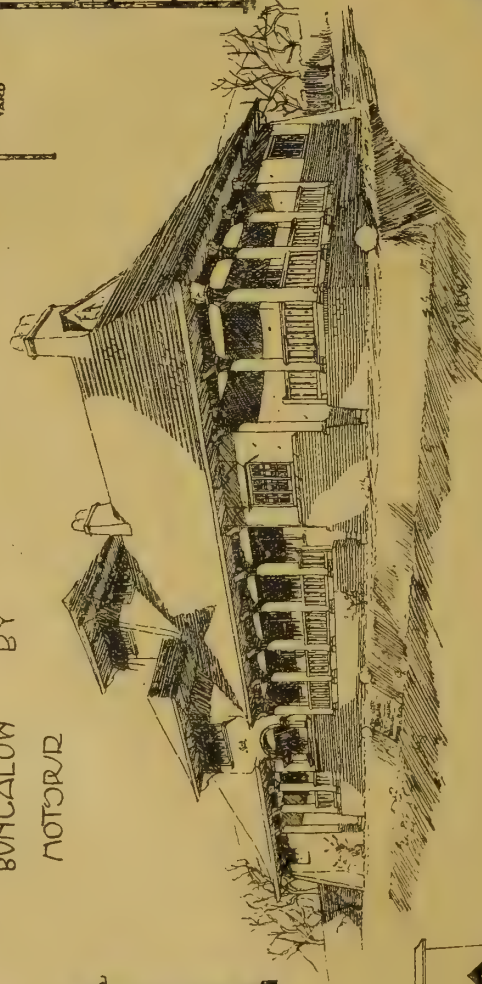

EAST ELEVATION

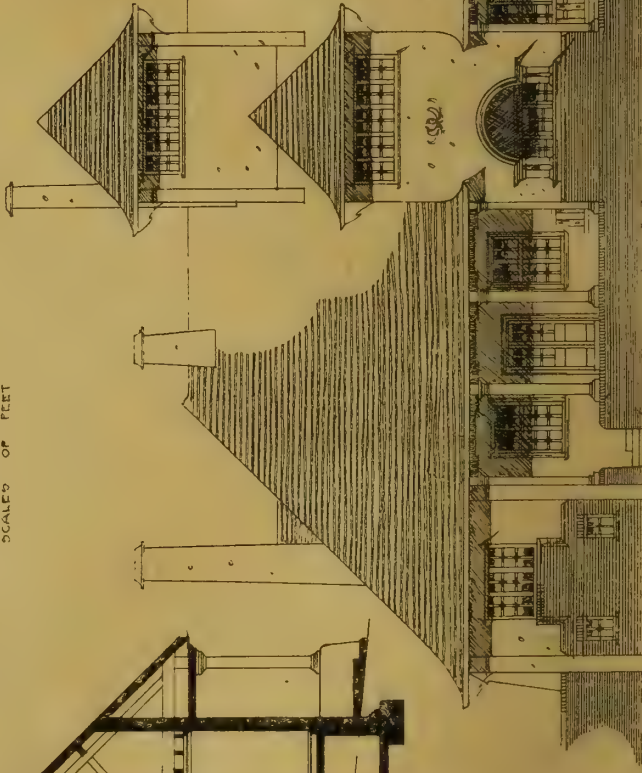

WEST ELEVATION





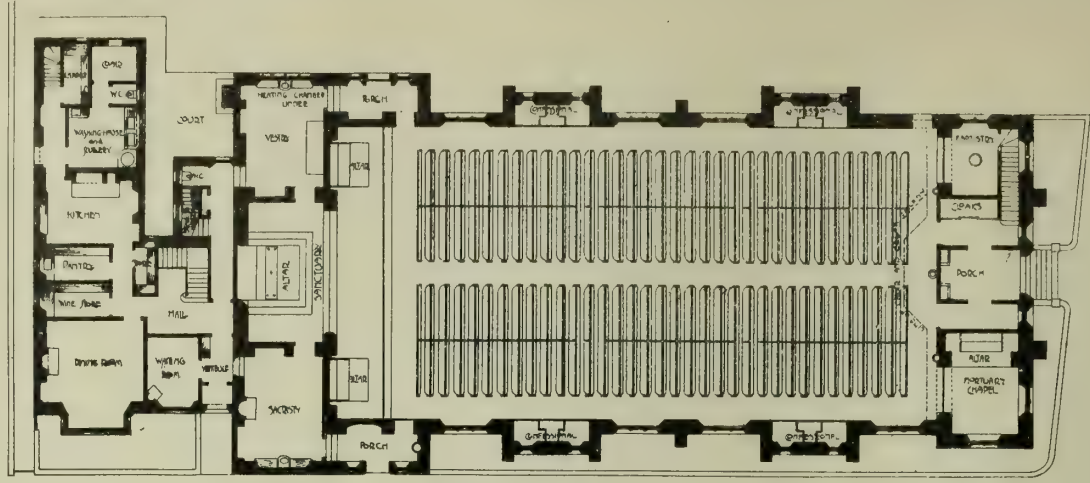

GROUND FLOOR PLAN

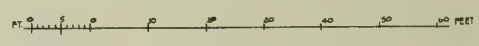

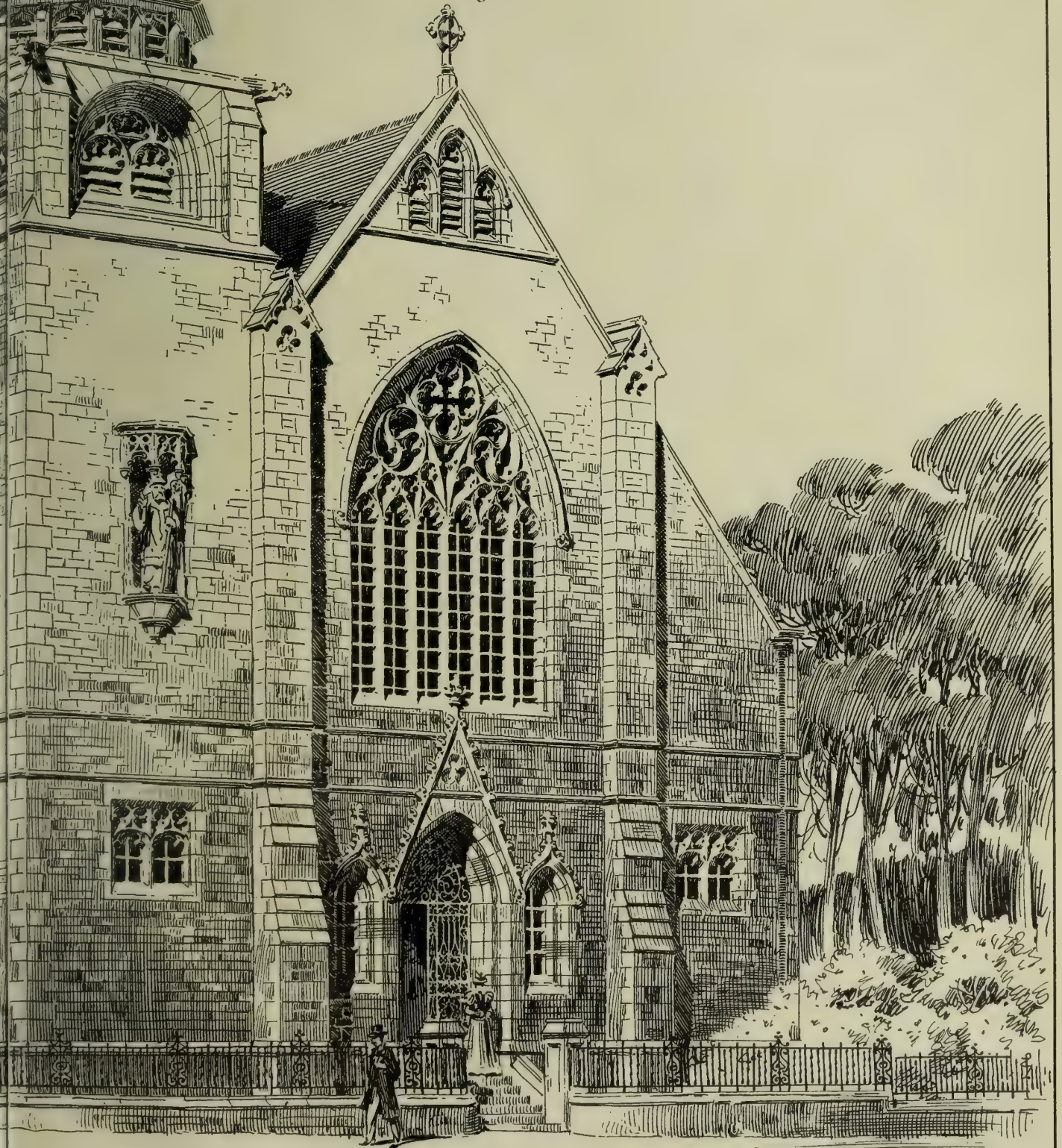





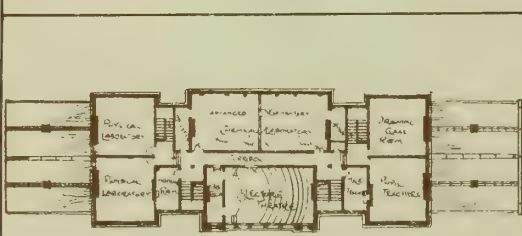

The First Floor Plan

HIGHER GRADE SCHOOL, SCARBOROUGH.

HALL, COOPER AND DAVIS ARCHITECTS SCARBOROUGH AND WESTMINSTER

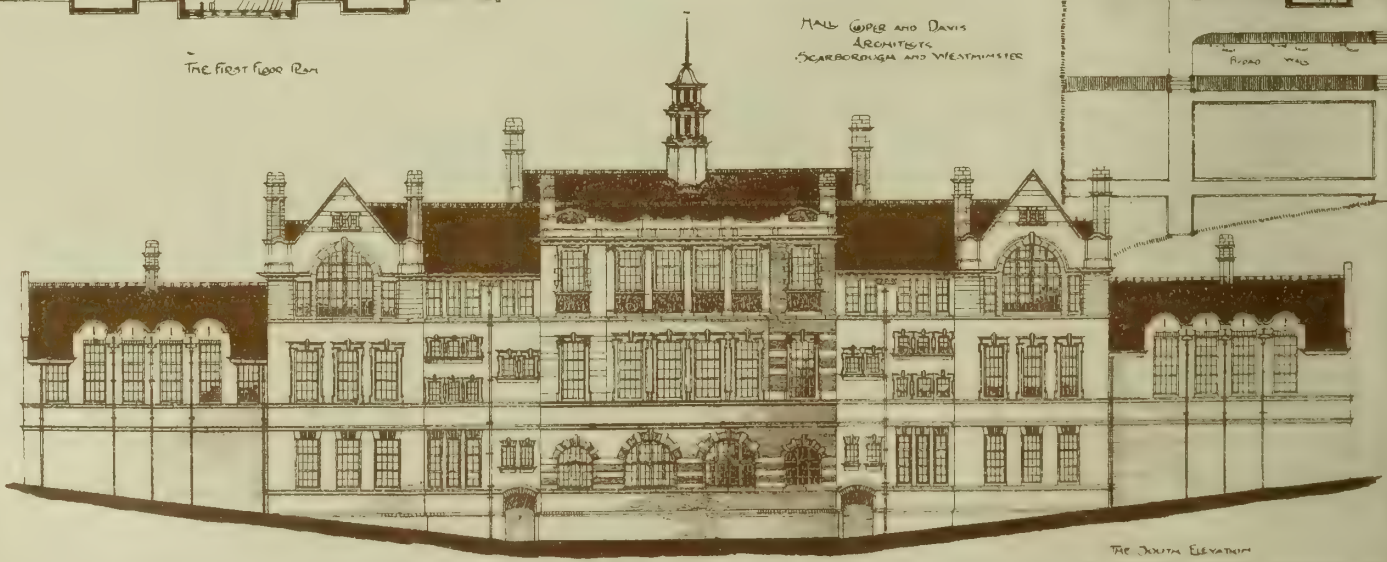
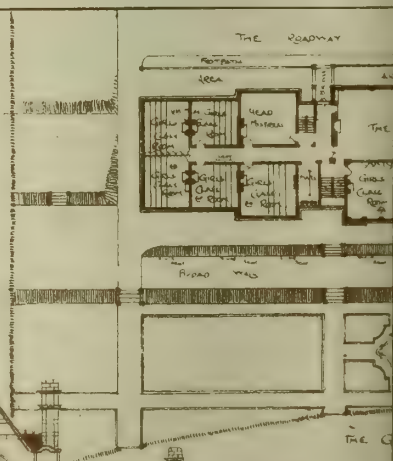

THE SOUTH ELEVATION

MAY 20, 1898.

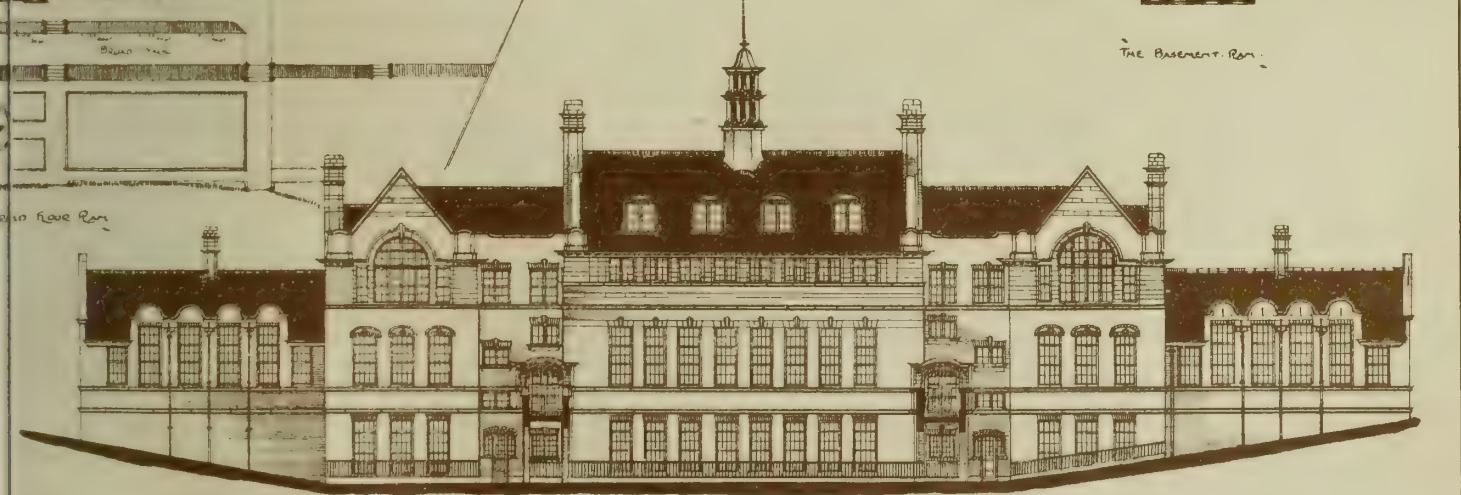
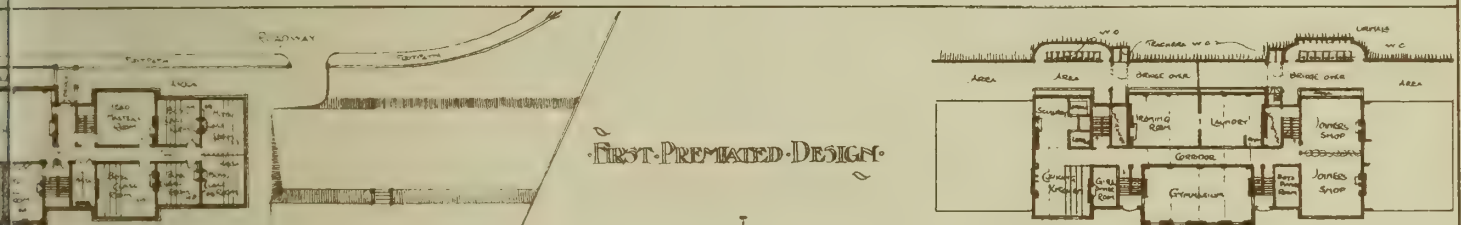

THE NORTH ELEVATION







THE CAPITAL & COUNTIES  
BANK - YEovil  
J. NICHOLSON, JOHNSTON A.R.C.S.A.  
21, PRINCES ST. YEovil.





B.N.D.C. A. HILLSIDE.  
 BUNGALOW by PANTILE.

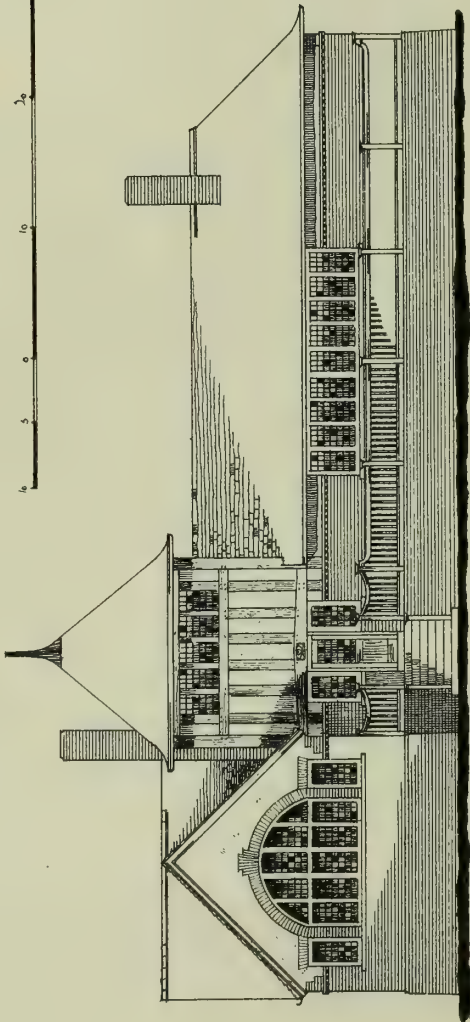
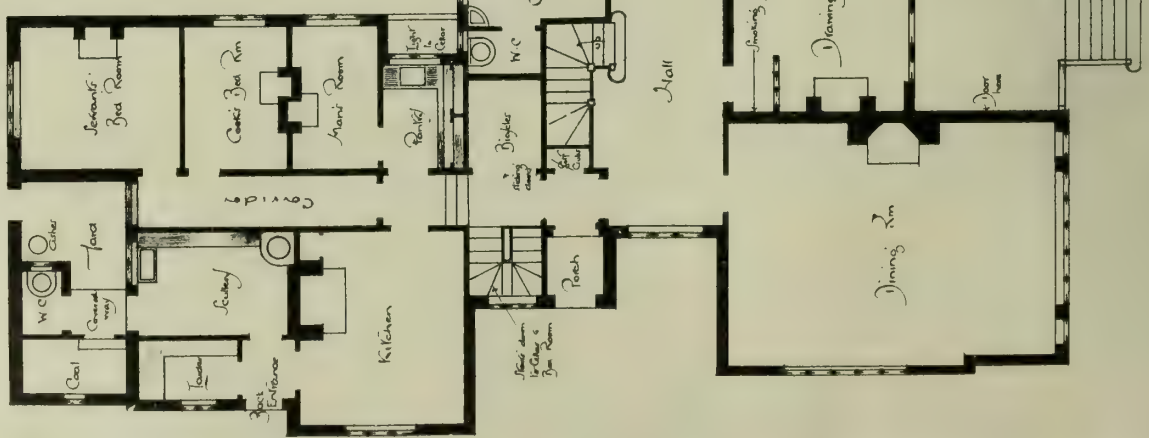

West Elevation

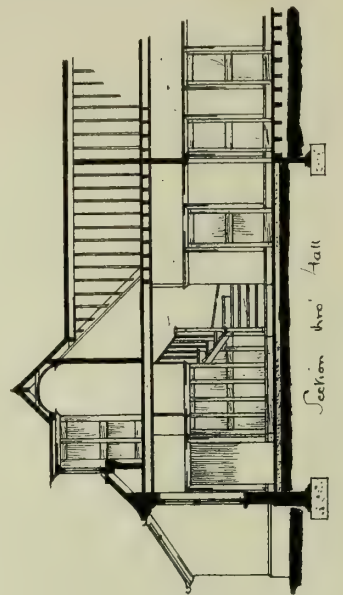

Section thro' Hall

PLACED SECOND

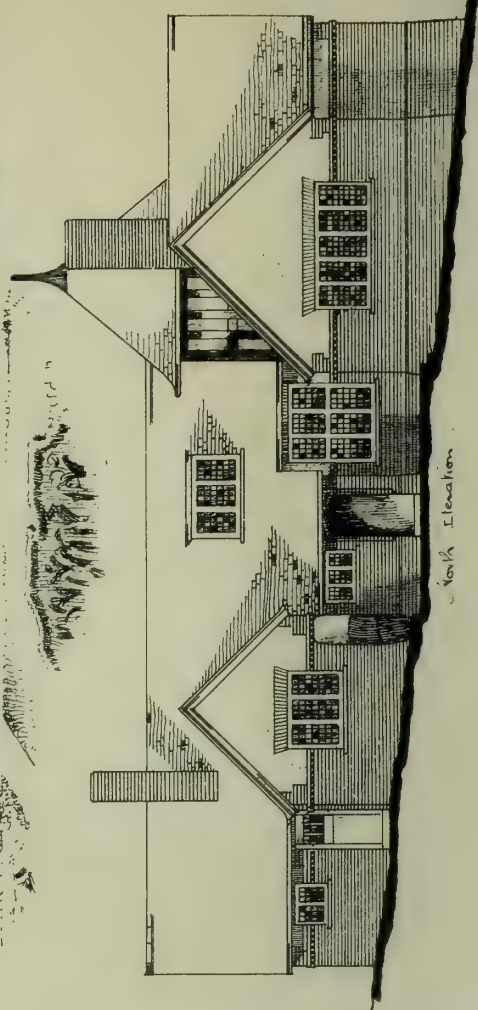

North Elevation

THE BUILDING NEWS, MAY 20, 1898.

# THE FASSMORE EDWARDS HOLIDAY HOME FOR CHILDREN

IN CONNECTION WITH  
THE SUNDAY SCHOOL UNION

CLACTON-ON-SEA Charles Bell R.M.B.A.  
Architect

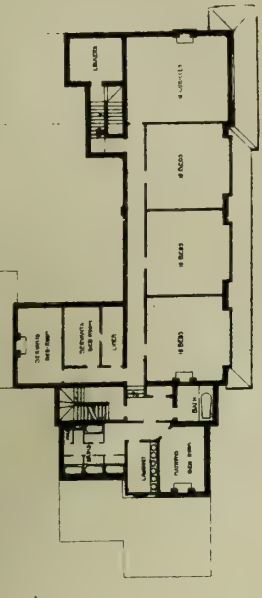
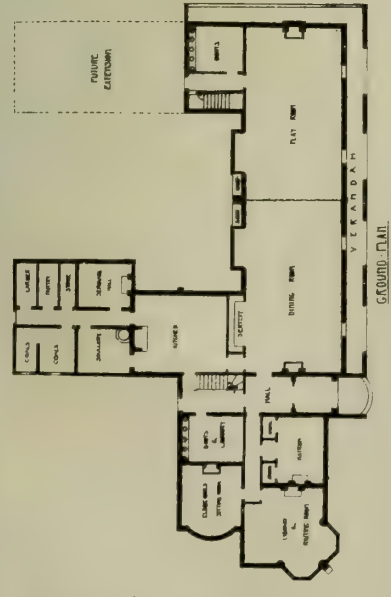

FIRST FLOOR PLAN (G.O.)

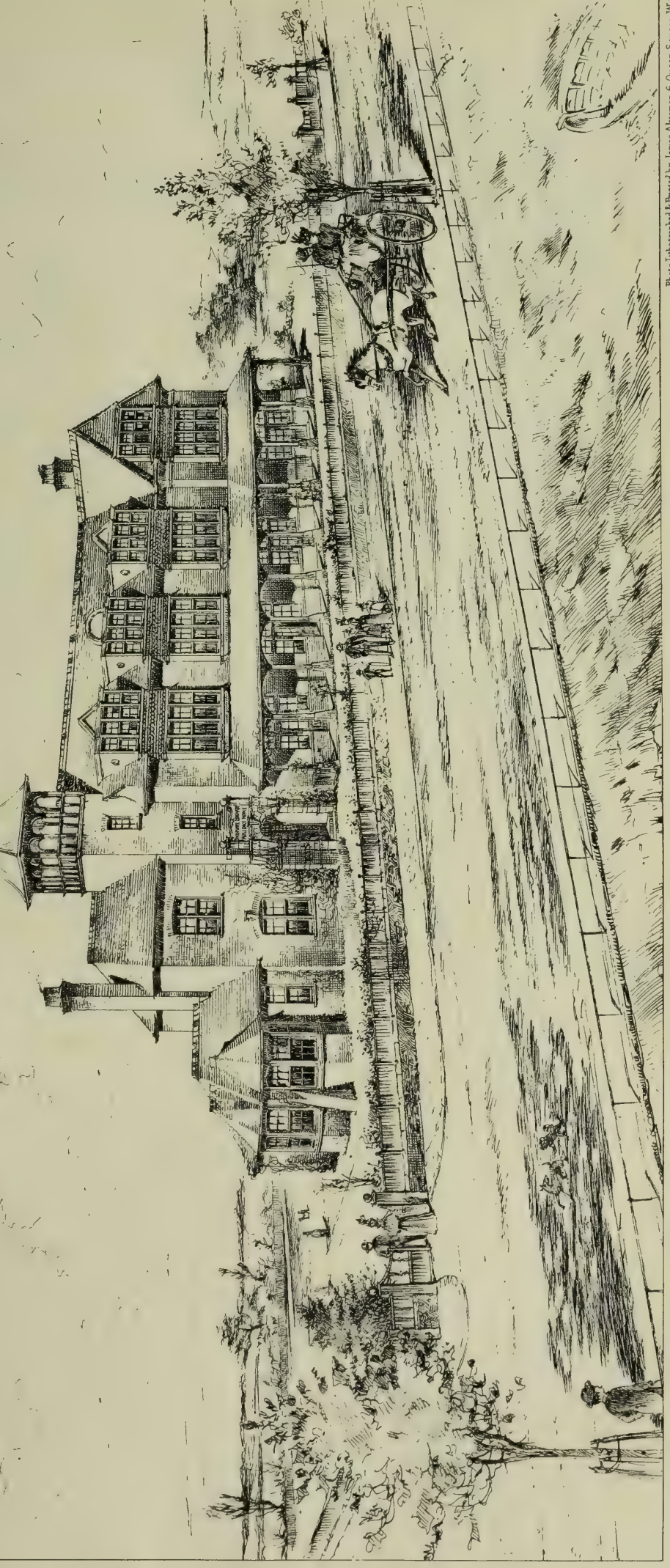









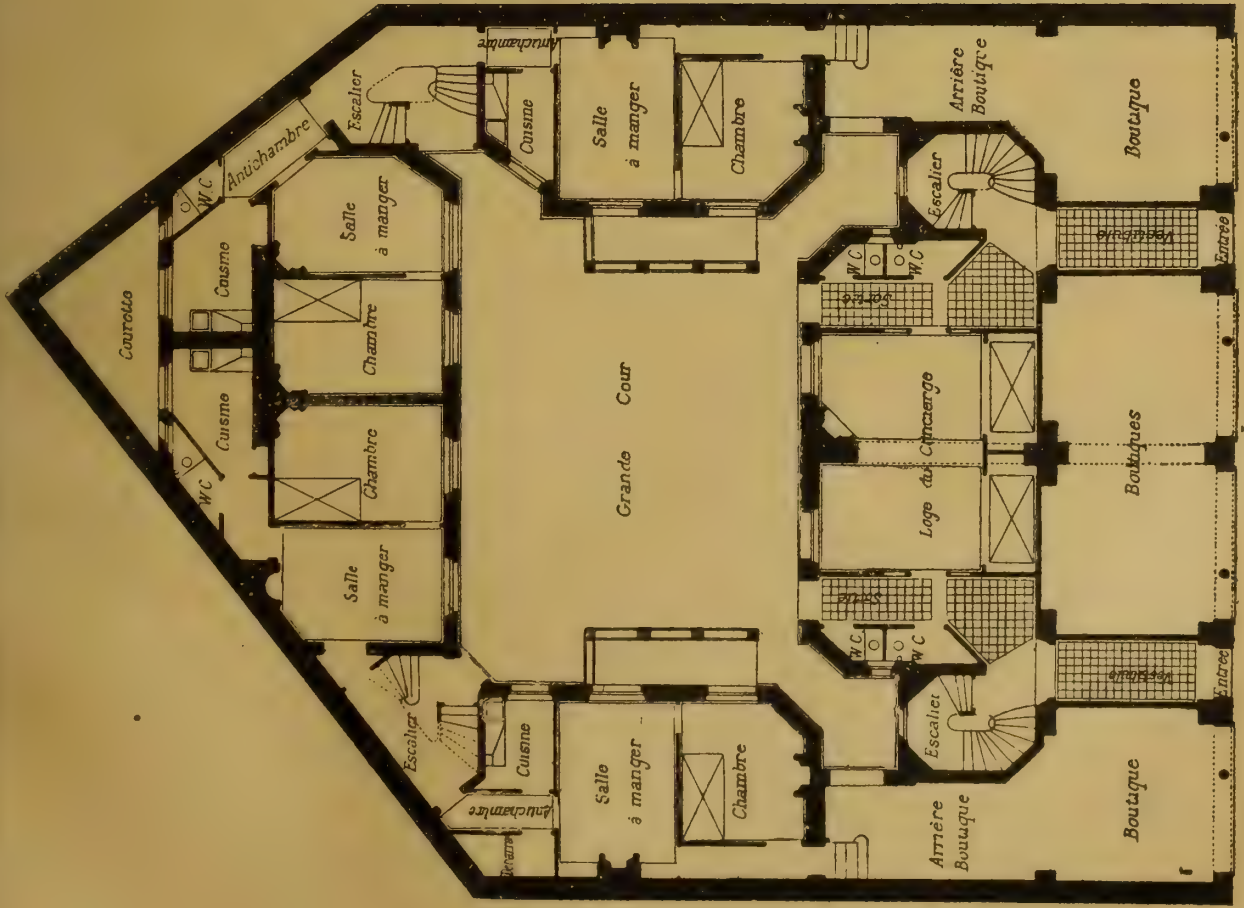

PLAN DU REZ-DE-CHAUSSÉE



MAISON DE RAPPORT, PARIS.

## TO CORRESPONDENTS.

[We do not hold ourselves responsible for the opinions of our correspondents. All communications should be drawn up as briefly as possible, as there are many claimants upon the space allotted to correspondents.]

It is particularly requested that all drawings and all communications respecting illustrations or literary matter should be addressed to the EDITOR of the BUILDING NEWS, 392, Strand, W.C., and not to members of the staff by name. Delay is not unfrequently otherwise caused. All drawings and other communications are sent at contributors' risks, and the Editor will not undertake to pay for, or be liable for, unsought contributions.

Cheques and Post-office Orders to be made payable to THE STRAND NEWSPAPER COMPANY, LIMITED.

## TERMS OF SUBSCRIPTION.

One Pound per annum (post free) to any part of the United Kingdom; for Canada, Nova Scotia, and the United States, £1 6s. 0d. (or 6dols. 30c. gold). To France or Belgium, £1 6s. 0d. (or 3fr. 30c.). To India, £1 6s. 0d. To any of the Australian Colonies or New Zealand, to the Cape, the West Indies, or Natal, £1 6s. 0d.

## ADVERTISEMENT CHARGES.

The charge for Competition and Contract Advertisements, Public Companies, and all official advertisements is 1s. per line of Eight words, the first line counting as two, the minimum charge being 6s. for four lines.

The charge for Auctions, Land Sales, and Miscellaneous and Trade Advertisements (except Situation advertisements) is 6d. per line of Eight words (the first line counting as two), the minimum charge being 4s. 6d. for 40 words. Special terms for series of more than six insertions can be ascertained on application to the Publisher.

Front-page Advertisements 2s. per line, and Paragraph Advertisements 1s. per line. No Front-page or Paragraph Advertisement inserted for less than 5s.

Advertisements for the current week must reach the office not later than 3 p.m. on Thursday. Front-page Advertisements and alterations in serial advertisements must reach the office by Tuesday morning to secure insertion.

## SITUATIONS.

The charge for advertisements for "Situations Vacant" or "Situations Wanted" is ONE SHILLING FOR TWENTY-FIVE WORDS, and SIXPENCE for every eight words after. All Situation Advertisements must be prepaid.

## NOTICE.

Bound copies of Vol. LXXXIII. are now ready, and should be ordered early (price Twelve Shillings each), as only a limited number are done up. A few bound volumes of Vols. LXXXIX., XL., XLI., XLVI., XLIX., LI., LIII., LVIII., LIX., LXI., LXII., LXIII., LXIV., LXV., LXVI., LXVII., LXVIII., LXIX., LXX., LXXI., LXXII. may still be had, price Twelve Shillings; all the other bound volumes are out of print. Most of the back numbers of former volumes are, however, to be had singly. Subscribers requiring any back numbers so complete volume just ended should order at once, as many of them soon run out of print.

RECEIVED.—P. D. A.—I. N. and Co.—S. O.—H. A. G.—N. C.—S. N.—W. V. B.—N. D.

## Correspondence.

## A MATTER OF LIFE AND DEATH.

To the Editor of the BUILDING NEWS.

SIR,—The long list of iron-column buildings which have collapsed—not in a few hours, but actually in a few minutes—after they once caught fire, has now been added to by the swift destruction of Spurgeon's Tabernacle, at Newington. Six thousand people used to meet there week by week. Six thousand might have been there when it suddenly blazed up the other day, and a thousand or two, in all probability, would then have been roasted alive.

The London County Council, I believe, have the power of issuing, at any moment, regulations which would make it imperative to surround all metal columns in new public buildings of this class with a fireproof casing. Will they do it now, before the Tabernacle is rebuilt, or are they waiting to see a congregation burnt alive before they act?—I am, &c., F.R.I.B.A.

## WESTMINSTER BUILDING DISASTER.

SIR,—As I find that some misconception has arisen, may I beg the favour of your insertion of a note in your next report of this case, to the effect that I am in no way concerned with the buildings in question.—I am, &c.,

JOHN W. SIMPSON, A.R.I.B.A.

10, New Inn, Strand, London, W.C., May 18.

## A CORRECTION.

SIR,—We beg to draw your attention to an error in your otherwise excellent report of the

meeting of the Society of Architects on the 5th inst. As this is calculated to do us some harm, and lead to a misconception, we shall be glad if you will kindly correct it in your next issue. You report me as saying "that we had executed mosaic work in baths at 6d. per square yard." This, of course, is a mistake; it should be 6s. per yard.

Though the price of mosaic has been greatly reduced in recent years, we are very much afraid we shall never be able to do it so low in price as 6d. per yard.—I am, &c., L. SCHLANTHEIM.

## CHIPS.

In the case of John Crow, of Wickham-road, Brockley, S.E., and Great Bridge, Staffordshire, brick manufacturer, the discharge from bankruptcy has been suspended for two years, ending April 10, 1900.

Sir J. E. Millais's great picture "The Order of Release," lately presented by Mr. Tate to the Gallery of British Art, is now added to the collection of Sir J. E. Millais's pictures in the room set apart for the "Tate Gift."

Some time ago it was decided at a public meeting in Edinburgh to commemorate the late Dean J. F. Montgomery by some permanent memorial. The committee have decided to place a recumbent effigy of the dean in marble in St. Mary's Cathedral. About three-quarters of the necessary sum, £1,000, has been subscribed.

Mr. Walter Armstrong, Director for Art, in the Science and Art Department, will definitely retire from the service in September next. The post, in relation to the art education of the country, is of the greatest importance, therefore in art circles the prospective vacancy is already exciting much interest, and several well-known names are mentioned in connection with it, prominently Mr. Alfred Gilbert, R.A., Mr. Herkomer, R.A., and Mr. Walter Crane.

The foundation-stone of the new Roman Catholic schools at Kendal in memory of the late rector, Dean Gibson, who was 47 years in charge of the mission, has been laid. They are estimated to cost £4,000. On the ground floor are a mixed schoolroom, infants' schoolroom, three classrooms, and the boys' covered playground. At the rear of the buildings are girls' and infants' covered playground, and a workshop for manual instruction.

In the case of John Harvey Coney, Coleman-street, E.C., trading with Charles Morris Cooke as builders, the discharge from bankruptcy has been suspended for two years, ending April 6, 1900.

The Ipswich Corporation have decided to erect a new central fire-brigade station in Bond-street, the old one in Waterworks-street being inadequate in size. Provision is made for the superintendent, deputy superintendent, and watchman to live on the premises, and there is also stabling for three horses, with engine-room, yard, and hose-drying tower. Mr. E. Buckham, M.Inst.C.E., the borough surveyor, prepared the plans, and the tender of Messrs. T. Parkington and Son, of Crown-street, Ipswich, has been accepted for carrying out the work at £3,850. The corporation have also adopted plans by Mr. Buckham for providing a 30in. storm-water overflow sewer into the river at an estimated cost of £4,000.

The work of enlarging the London and North-Western Railway station at Crewe, and providing a complete duplicate of lines through it, is being pushed on with the utmost speed. One thousand men are now at work in the excavations tunnelling, and this number will be greatly augmented as soon as there is additional room for them to work.

The Dean and Chapter of Lincoln have appointed Sir A. W. Blomfield, A.R.A., as architect to the cathedral in succession to the late Mr. John L. Pearson, R.A.

Mr. Arthur Wellesley Soames, M.A., the newly-elected member for South Norfolk, is an architect by profession, and is the youngest son of the late Mr. William Aldwin Soames, of Brighton, and was born on November 30, 1852. He matriculated at Trinity College, Cambridge, graduated in 1877, and proceeded M.A. in 1880. He married, in 1876, Eveline, the eldest daughter of the late Mr. T. Horsman Coles, of St. Helen's. He has twice—in 1892 and 1895—unsuccessfully contested Ipswich as a Liberal, and now enters Parliament for his first time.

A monument is about to be erected in Dandalk to the memory of the men who fought and died for Ireland in the insurrection of 1793. The design is by Mr. Herbert G. Barnes, sculptor, of Dublin, whose offer to execute the work for £2,500 has been accepted. The monument will be of Kilkenny limestone. It will stand about 23ft. high, the statue of a feminine figure holding a flag being 7ft. 6in. high. The base will be about 8ft. square.

## Intercommunication.

## QUESTIONS.

[11943.]—Chimney.—Will any kind reader with experience in building tall chimney-stacks kindly suggest the best method of handling and fixing heavy stone cornice and blocking at top, and oblige?—STONE.

[11949.]—Perspective.—Could any reader tell me the method of preparing perspective drawings of villas, public buildings, &c.? I have a knowledge of elementary perspective. Are there any books on the subject on any special instruments required?—BEGINNER.

[11950.]—Water at West Norwood.—Can any of your numerous readers tell me how far I shall have to drill down to find water at West Norwood? How can I tell if there is water below or not?—DRILL.

[11951.]—Artesian Well.—I am desirous to sink an artesian well in a country district, clay soil, where the surface water supply is short in dry summers and of doubtful quality. There are only seven or eight houses. It is an elevated position. Do you know of any good work on the subject? I have looked up some encyclopaedias, but cannot get enough information. Could any of your readers who have knowledge or experience give me any hints as to determining the best position likely to find, and the possible cost?—VANDYKE.

[11952.]—Measurement of Rough Elm.—Will any of our readers give a correct rule for finding out the actual contents of a log of elm? Here is a rule, which is very old, by Dr. Hutton:—Multiply the square of one-fifth of the girth by twice the length, product equals the content. I have measured up some hundreds of logs after having been cut into plank and board, and although I have allowed for sawkerfs, and actually measured up the offal remaining, the cubical contents of the converted material plus sawdust, plus offal, does not agree with the so-called original contents.—PEGGY.

[11953.]—Tramcar Construction.—Can anyone inform me as to the peculiar structure of the arch as seen in the roofs of tramcars and omnibuses, whereby it is so stiffened apparently without the use of tie-rods that it is independent of the lateral support usually accorded to arch-work?—the sides of such vehicles being evidently incapable of taking any side-thrust of practical value, and the weight of top of a fully-loaded tramcar must be considerable.—H. R. B.

[11951.]—Water in Gaspipes.—Can any reader tell me the best way to fix gaspipes and fittings, so that the water will not collect in the brackets and clog the burners? This occurs mainly where the pipes are most exposed to cold draughts. Would it be well to arrange the pipes to slope downwards towards the meter, as steam-pipes should slope downwards to boiler for return of water? Any hints would oblige.—NOTTINGHAM.

[11955.]—Papier-Mache Bookshelves.—In Mr. Burgoyne's recent work on "Library Architecture," the above is referred to, but no particulars given. As this is a subject of great importance to architects and librarians, I write in the hope that some of your readers are in a position to state the benefits to be derived from the use of papier-maché shelves. What thickness is required to make a 36in. by 5in. papier-maché shelf sufficiently strong for its purpose, and is it likely to warp or bend with long-continued pressure? Further, what would be the cost of such a shelf if an order was given for, say, 500 of like dimensions? Is papier-maché cheaper than wood, or adapted in any way for library fittings?—LIBRARIAN.

## REPLIES.

[11944.]—Cambered Niches.—Will "A. B." refer to my letter, p. 583, April 22, under heading "Ornamental Brickwork: Arches," for information as to works on the subject of his question?—ARCHITECT.

[11946.]—Hot-Water System.—From an examination of "H. M. X.'s" system, I should say the circulation, if possible, would be very uncertain and partial. Such a lofty reservoir in connection with the boiler, or in continuation of it, would scarcely get hot, and two currents would be established on one side. A column of hot water would flow up, but be quickly cooled by the descending cold current of water. The large mass of water in the reservoir would be a long time getting warm.—G. H.

Mr. Passmore Edwards will open the new wing of the Pegwell Bay Convalescent Home at Ramsgate on Saturday, July 2.

A report has been issued by Mr. R. G. Nicol, C.E., harbour engineer, Aberdeen, in regard to the reconstruction of Regent Bridge in that town. The new bridge will be of the single-swing type, worked by hydraulic power, and will be sufficiently strong for the heaviest traction engine and cart traffic. The estimated cost is £49,740, of which £4,470 will be required for temporary works.

The ceremony of cutting the first sod in connection with the new drainage scheme to be carried out at Pokesdown, a suburb of Bournemouth, took place on Friday afternoon. The works are to cost about £20,000.

Mr. W. E. Duke died suddenly on a tramcar at Plymouth on Friday. He was chairman of the Lydford Parish Council, and a large employer of labour at the granite quarries near Princetown.

At a recent special meeting of the Morecambe District Council, Mr. Nicolls, C.E., presented plans and details of a sewerage scheme for the district. After some discussion it was resolved that the plans be approved, and that the council make the necessary application to the Local Government Board to sanction the borrowing of £60,000, the cost estimated by Mr. Nicolls.

## LEGAL INTELLIGENCE.

**WOOD V. MONK AND NEWELL.**—On May 6, before Mr. Justice Wills and Mr. Justice Kennedy, sitting as a Divisional Court, in the Queen's Bench Division of the High Court, the case of Wood v. Monk and Newell came on for argument on appeal from the West Bromwich County-court, Staffordshire. Mr. Bankes said this was an appeal by the defendants. The plaintiffs, Messrs. Wood, are brickmakers at West Bromwich, and the defendants Liverpool contractors. The action was brought by plaintiffs to recover the balance of an account for bricks supplied. Defendants, however, put in a counter-claim for loss alleged to have been sustained by the defendants in consequence of the bricks supplied not being of the quality contracted for. The County-court judge held that the counter-claim could not be gone into, nor could the defendants raise any point about the quality of the bricks, because they had accepted them, and not rejected them. Defendants' witnesses were never heard at all on the point, and he never heard of a counter-claim being rejected on such a ground before. It was entirely wrong, he submitted, and the fact was the judge was misled by a somewhat specious case which was quoted to him, which had nothing whatever to do with the case. The blue bricks in question were to be used in some work defendants were doing for the London and North-Western Railway at Heckmondwike, in Yorkshire, and it was stipulated the bricks should be of a quality to satisfy the London and North-Western Railway. Mr. Disturnal argued that the judge was right; but Mr. Justice Wills said it was clear there must be a new trial, as the counter-claim had not been heard at all. Appeal was allowed for a new trial, with costs.

**IN RE C. J. WESTWOOD.**—An adjourned sitting or public examination was heard before Mr. Registrar Linklater on Tuesday, under a receiving order made against Charles John Westwood, described as a railway contractor, carrying on business at 11 and 12, Clement's-lane, Lombard-street, E.C., under the style of C. J. Westwood and Co. The statement of affairs showed gross liabilities £41,545, of which £13,359 were expected to rank for dividend, with assets £13,329. From 1888 to 1895 the debtor was in partnership with another person as railway and tramway contractors. At the latter date the firm was dissolved, and there were two important contracts then on hand, one being for the construction of a railway in the Transvaal, and the other for the construction of the Newport, Godhill, and St. Lawrence (Isle of Wight) Railway. The debtor's partner took over the first contract, and he took over the second. He also received acceptances amounting to £23,000 in consideration of relinquishing his interest in the Transvaal contract. He discounted the bills and used the proceeds in connection with the Isle of Wight Railway. The contract price was £160,000, payable in shares and debentures as the work progressed. At the date of the receiving order £81,200 shares and £25,900 debentures had been issued. In October last he was compelled to suspend operations, £19,000 further being then required to finish the construction of the line, but arrangements were in progress under which the work would probably be completed and the balance of the shares and debentures taken up. This would enable him to pay his debts in full. The examination was adjourned until July 12 next.

**SEWERAGE DISPOSAL DIFFICULTIES AT MANCHESTER.**—The Stipendiary Magistrate for the county of Lancashire (Mr. Yates, Q.C.) dismissed, on Friday, the application of the Manchester Corporation for a further extension of the time for constructing sewerage works at Davyhulme. He held that the Corporation has at present no effective scheme for dealing with the sewage of the city and the prevention of the pollution of the Ship Canal. The bare facts, he said, were that the sewage of an ever-increasing population, now amounting to 600,000, was being turned into an almost stationary body of water unpurified; that this had been going on to a greater or lesser degree for at least five years; and that the Corporation were no nearer a final settlement of the question than they were in 1893. The Corporation have decided to appeal against this decision.

**THE MEDICAL OFFICER OF HEALTH AND HIS ALLEGED INSANITARY HOUSE.**—In the Queen's Bench Division of the High Court on Monday, before Mr. Justice Mathew and a special jury, the hearing was concluded of an action in which the trustees of the Sesame Club sought to recover from Dr. James Edmunds, medical officer of health for the parish of St. James's, Piccadilly, damages for fraudulent misrepresentations alleged to have been made by the defendant as to the sanitary condition of a house, No. 39, Dover-street, of which the defendant was the owner, and which the plaintiffs had taken on lease for the purposes of their club. For the plaintiffs it was contended that the defendant had alleged that the sanitary arrangements of the house were perfect, and could not be surpassed, while in fact the drainage was found to be so seriously

defective that the whole of the old brick drains in the basement had to be taken up and replaced by new ones. Among the witnesses for plaintiffs were Mr. Rogers Field, who said he found the house to be in a most unsanitary condition. The defendant denied that he had made the representations alleged, and that he had given plaintiffs and a Mr. Harvey, who was an architect and a member of the club, the fullest opportunity of examining the house for themselves. In summing up, Mr. Justice Mathew referred to the decision of the House of Lords in *Peck v. Derry*. The jury, after long deliberation, returned a verdict for the plaintiffs. The question of damages was reserved for further consideration.

**DISPUTE AS TO BRICKMAKING ROYALTIES.**—**BRADSHAW V. BUCHANAN.**—At the Liverpool Assizes, on May 11, before Mr. Justice Bruce, sitting without a jury, Richard Bradshaw, a practical brickmaker, of Liverpool, brought an action for royalties, and for damages for infringement of letters patent, against Buchanan and Sons, Caledonia Foundry, Bootle. The dispute had arisen with regard to royalties claimed by the plaintiff in respect of the "Little Wonder" brick-making machine, in connection with which he had taken out two patents. Defendants had made some of the machines on terms agreed upon between the parties, which included payment to the plaintiff of £50 royalty on each machine which was to be sold for £200. Since 1893 plaintiff contended that he had not been paid anything by the defendants, and had not been asked to pass any machines, although several were made. The defence was that at first the agreement between the parties was that defendants should receive £200 on each machine, and as they were sold for £250 the plaintiff received his £50 in every case. It was also agreed that plaintiff should obtain the orders for the machines, and superintend the fixing of them. In 1891 defendants lent plaintiff £20, and a new agreement was made whereby plaintiff agreed to receive only £20 for each machine for which he obtained orders, fixing the machines and paying the carriage on them; he consequently abandoned all right to commission. As a matter of fact he did not again, until April, 1897, ask for commission or royalties, and in the mean time defendants had been paying commission to other persons on orders, besides defraying the cost of carriage and fixing the machines. Mr. Justice Bruce, in giving judgment, said that it was extremely difficult to know what the arrangement was between the parties. He was obliged to be guided to some extent on the probabilities of the case. He considered that the £50 on the machines was to be paid in the nature of a royalty to the plaintiff by the defendants for the use of the former's patent, whether he obtained the order for the machines or not. His Lordship gave judgment for the plaintiff on the claim for £100 with costs, and for the defendants on the admitted counter-claim for money lent for £38 19s. 9d.

The remaining plain window in the baptistry of the parish church, Bury, Lancs, is about to be filled with stained. The artist is Mr. C. E. Kemp, of Nottingham-place, W.

The ceremony of cutting the first sod in connection with No. 1 contract of the Cardiff Railway, for the construction of the line from a junction with the Rhymer Railway, near Roath Park to Tongwynlais, took place last week. The contract has been let to Messrs. Monk and Newell, of Liverpool, and the work will be carried out under the superintendence of Mr. Allen, resident engineer. Sir Douglas Fox and Mr. B. White are the engineers for the line for the Cardiff Railway Company.

Fewer properties are in the auction market at the present time than was the case in May last year, and the returns from Tokenhouse-yard are consequently in arrear. The aggregate realisation last week was £186,056, as compared with £245,576 for the corresponding week in 1897. At the same time, the large amount of business done in the earlier months still places this year in advance of several recent ones. The chief feature of the week was a freehold estate of 50 acres at Streatham, with seven residences, the greater part of the land being available for building operations. Messrs. Farebrother, Ellis, and Co. were the auctioneers for this valuable lot, which was offered on Thursday, but had, however, to be withdrawn at £150,000.

A new railway from Oban a'ong the west coast of Scotland to Ballachulish on Loch Leven is about to be constructed, the Callander and Oban Railway Company having let the contract to Mr. John Best, of Leith, for the railway, and to Messrs. Arrol Brothers for a large bridge on the railway. The line is 28 miles long, and the earthworks are not very heavy. The ruling gradient is one in 70, while much easier gradients predominate. Two narrow inlets of the sea have to be crossed, one by a cantilever bridge 735ft. in length, the other by two centre spans of 150ft. each, and two side spans of 60ft. each. The line is expected to be completed in three years, and Sir J. Wolfe Barry, K.C.B., is the engineer.

## WATER SUPPLY AND SANITARY MATTERS.

**THE LONDON WATER SUPPLY.**—At Monday's sitting of the Royal Commission, which is inquiring into this subject, evidence was given as to the water supply of Paris by M. Gaston Cadoux, Chef de Bureau at the Prefecture of the Seine. M. Cadoux was of opinion that the arrangement by which the ownership and management of the water supply had been transferred from a private company to the Municipality of Paris had been much to the advantage of the city. Sir A. R. Binnie, engineer-in-chief to the London County Council, was recalled, and gave evidence as to the probable increase in the discharge of sewage into the Thames at Barking and Crossness.—The House of Commons Committee which has been considering the Southwark and Vauxhall Water Company's Bill has found the preamble proved, but subject to the insertion of clauses providing that if the undertaking be purchased within ten years of the passing of the Bill by any public body no additional value shall be deemed to be given to the undertaking by powers conferred by the Bill other than actual expenditure, and also imposing certain restrictions on the quantity of water to be taken by the company from the Thames.

**MORECAMBE SEWERAGE.**—At a special meeting of the Morecambe Urban District Council held on the 17th inst., the details of the sewerage scheme, including that of Bare, were approved, and it was unanimously resolved that application be at once made to the Local Government Board for sanction to borrow £60,000 to carry out the works. The engineer to the scheme is Mr. H. Bertram Nichols, C.E., of Grosvenor Chambers, Corporation-street, Birmingham.

**THE WELSH WATER SCHEME FOR BIRMINGHAM.**—Steady progress continues to be made with the Welsh water scheme. The completion of the Knighton tunnel was announced on Friday. Forming portions of the conduit from the Elan Valley to Birmingham will be two tunnels, about 8ft. in diameter. One of these,  $4\frac{1}{2}$  miles in length, and nearest to the Elan Valley, is the Dolau tunnel. The other is the Knighton tunnel, extending from the town of Knighton to the Lugg Valley, a distance of  $2\frac{1}{2}$  miles. Headings for this tunnel were commenced at either end, and at the time of the visit of the Birmingham City Council last spring, 1,700 yards had been driven from Knighton and 1,600 from the other end, leaving about 1,000 yards still to pierce. The two sets of excavators have now been able to join hands. The Dolau tunnel, owing to its greater length and the need for shafts to remove the excavated material, was commenced in two sections. The first half was completed a month ago, and, although the calculations and measurements had to be made upon the data afforded by a base line of only 16ft. at the bottom of a 300ft. shaft, they were so accurately worked out that the centre lines of the two headings met accurately as regards level, and with a horizontal divergence of no more than  $\frac{1}{2}$  in.

## CHIPS.

A cottage hospital—the gift of Mrs. Aitken—is approaching completion at Ramsbottom, Lancs. Mr. C. F. Haywood, of Accrington, is the architect, and the various trades are being carried out by local contractors.

The Lancashire County Council is taking steps with a view to the erection of a new sessions hall in the centre of Preston.

The subscribers to the technical school at Dawsbury have resolved to enlarge the hall at a cost of from £4,500 to £5,000, and have instructed Mr. J. Lane Fox, the architect, to prepare the necessary plans.

Foundation-stones of a new Wesleyan chapel were laid at Baranck, Northamptonshire, last week. The building will be Gothic in style, will seat 200 persons, and will cost £560. Mr. William Hinson is the architect, and the contractors are Messrs. Hinson, of Stamford.

The buildings occupied by the Architectural and Engineering Departments of the Massachusetts Institute of Technology, in Boston, took fire a fortnight since, from the overturning of a tinman's furnace on the roof, and the upper story of the building was destroyed. The valuable library of the Architectural Department, which is kept in the next lower story of the building, narrowly escaped destruction; but fifty students devoted themselves to its rescue, and all of the books and photographs were saved uninjured, though the casts were destroyed. The Engineering Library was saved in the same manner, with the valuable instruments belonging to the department.

A stained-glass window has been placed in the parish church of Larnie. It is of two lights, the subjects being the Annunciation and the Nativity, and the artists are Messrs. Guthrie and Wells, of London and Glasgow.

### PARLIAMENTARY NOTES.

NEW SCIENCE AND ART BUILDINGS. — Sir F. Powell asked the First Commissioner of Works whether, notwithstanding the first report of the Select Committee on the Museums of the Science and Art Department, 1897, plans were now being prepared for the concentration of the Science and Art Departments of the South Kensington Museum on the East side of Exhibition-road; and whether steps were also being taken for the renovation of the Geological Museum in Jermyn-street, though recommendations for its removal had been made by the Select Committee. Mr. Akers-Douglas: According to the announcement made to the House, plans for the proposed new Science and Art buildings are being prepared for the consideration of the inter-Departmental Committee now sitting and for the Government. I have already promised to make a statement to the House directly this Committee reports. In reply to the second question, as the stonework of the building referred to is in a dangerous condition, it is being repaired in accordance with the usual practice of this department.

### STATUES, MEMORIALS, &c.

WINDSOR CASTLE.—The monument which has been erected by the Prince and Princess of Wales to the memory of the Duke of Clarence and Avondale, in the Albert Chapel at Windsor Castle, has just been completed. It was designed and executed by Mr. Alfred Gilbert, R.A. The sarcophagus of Mexican onyx, which stands in the middle of the chapel, has now been surmounted by a group of statuary wrought in bronze, aluminium, and marble. A recumbent statue representing the Duke of Clarence attired in the uniform of his regiment, the 10th Hussars, and lying in the folds of the Garter robe, reposes upon the gunmetal bier. The military embroidery upon the collar and the cuffs and the aiguillettes are gilded, and the head and hands are sculptured in white marble. In the Prince's right hand is a drawn sword, and round the blade is a spray of olive leaves, the end resting upon an open gilt-edged Bible. The left hand will clasp a crucifix. The lining of the robe is composed of aluminium, and an angelic figure, also cast in aluminium, and holding a gilt corona twined with light foliage, kneels at the head, and near the feet will presently be placed a figure representative of "Love Mourning." The body of the tomb is protected by a bronze railing. This is divided into twelve panels, which are adorned with gilt-winged angels supporting statuettes. Alternating with these, and affixed to the grille pillars, are the escutcheons of various Royal houses, and whose armorial bearings are enamelled in gold and colours upon silver shields, while beneath are representations of the Orders of Knighthood connected with them.

### CHIPS.

The Bentham Trustees have presented a fine oil portrait of Robert Brown, the celebrated Scottish botanist, to the museum of the Royal Gardens at Kew.

Cardinal Vaughan laid the foundation-stone of a new Roman Catholic church in Romford-road, Ilford, on Saturday. The fabric has been dedicated to St. Peter and St. Paul.

The Episcopal cathedral in New York is going on slowly, and the trustees are beginning to consider what sort of stone to use for the exterior. The apse is already high above ground, in rough masonry, but will be faced, later, with the stone selected for the whole exterior. The doubt in the minds of the trustees is whether to choose granite or marble, some thinking that marble would be too conspicuous. The *American Architect* strongly advises the choice of one of the Massachusetts marbles, either that from Lee or Stockbridge, both of which have a creamy tint with blue veins.

Mr. Thomas Flood, of Sandy Hill, N.Y., died on April 26, aged 68 years. For 40 years he had been actively engaged as a contractor, and for a large portion of that time confined himself to canal work. His work is to be found on nearly every section of the Erie and Champlain canals. He, in company with Mr. J. H. Sherrill, built the State dam at Cohoes, N.Y.

The Queen has become the possessor of Mr. Holman Hunt's picture "The Beloved," which is at present in the New Gallery. It will be removed to Windsor at the end of June, when her Majesty returns from Balmoral. The Queen has also purchased the water-colour drawing "Portsmouth by the Sea," by William Callow, which is at present on view at the Royal Society of Painters in Water Colours.

The Wesleyan chapel at Aldemin's Green, Coventry, is about to be rebuilt from plans by Mr. T. F. Tuckner, of that city. It will be faced with red brick, with Bath stone dressings, and the floors will be of wood blocks. Accommodation will be provided for a congregation of 300 persons.

### Our Office Table.

In the entrance-hall of the Scottish National Portrait Gallery at Edinburgh, there is, at the first floor level, between the antiquarian and art sides of the building, a large square ambulatory carried on pillars, which form a Gothic arcading. Above the spandrels of the arches is a frieze space, and this and the surfaces below it have just been decorated by Mr. W. Hole, R.S.A., the cost being borne by Mr. J. R. Findlay. The paintings, which have been done in spirit fresco on the plaster of the wall, take the form of a procession representative of Scottish history from the earliest to latest times. A special study for the work has been made of costume and armour; and from the time of the Stuarts the portraits are more or less studied from contemporary records. The artist opens the record by painting a female figure symbolical of Caledonia, arrayed in green and purple draperies and golden armour, seated in a megalithic temple, and draws aside a curtain unfolding the past and revealing the future, symbolised by the deep blue vault of heaven spangled with stars. The procession begins with a representation of a man of the Stone Age, driving before him a wolf in a forest. Next is a group representative of the Bronze and Iron Age, who are attired in woven garments, and who carry ornaments and weapons. A group symbolising the Roman occupation of Scotland follows, and the one representing the introduction of Christianity to the country, and after these follow Picts, Culdees, and Vikings. A series of warriors, kings, and queens, and in modern times distinguished men of science, arts, and letters complete the pageant, which includes over 150 figures. The length of each wall is 20ft., the height of the frieze is 4½ft., and the figures have been painted to a 4ft. scale. The scheme is carried out as a piece of flat decoration. The spandrel spaces have been filled in with conventional flower ornament, and over each of the twelve pillars is a shield, on which is emblazoned the arms of Scottish Royal burghs. A scheme has been further sanctioned for the decoration, also by Mr. Hole, of the walls of the ambulatory with a series of Scottish historical scenes.

THE annual report of the council of the City and Guilds of London Institute has just been issued. The results of an inquiry made by order of the Treasury into fourteen English University colleges in receipt of Government aid was that the average percentage of expenditure on the teaching staff was 64.9 per cent., while the percentage under the same head at the institute's central technical college was 61.9, and at their technical college, Finsbury, 58.2. At thirteen colleges referred to each student paid on an average 49 per cent. of his annual cost, as compared with 51 per cent. at the central technical college and 34 per cent. at the Finsbury college. With regard to the central college, there had been a steady increase in the number of students seeking admission to the diploma courses of instruction, and 113 entered for the matriculation examination in September last, as against 100 in the previous year. Of the 229 students in regular attendance 96 were taking the engineering course, 78 the physical course, 25 the chemical course, and 31 special courses. The attendance at the Finsbury college also showed a steady increase. The development of the polytechnics round London had, however, affected the attendance of artisans at the trade classes, and steps were being taken to transfer these classes, with the exception of the cabinetmaking class, to an institution of a polytechnic character. The attendance and the high standard of work in the modelling, drawing and painting, and house decoration classes at the South London school had been well maintained, and the competitions for the studentships and medals had brought out some excellent studies. There had been a considerable development in the work of the technological examinations department. The total number of students in attendance at the 1,487 classes in technology only was 30,066, showing an increase of 3,457. The number in attendance at the registered classes for the current session was 34,227. The total expenditure of the institute during the past year amounted to £31,181, and the income was £33,694.

THE Lower House of Convocation for Canterbury considered, on Friday, the report of the Committee of the Lower House on Ecclesiastical

Dilapidations, and on the motion of the Archdeacon of Wells the following resolutions were agreed to:—(1) That after the experience of the general working of the Act since the year 1871, it is not desirable at present to call upon the Legislature to make any change in the present law. (2) That the attention of their lordships of the Upper House be drawn to the following points:—(a) To the fact that in some cases surveyors have been beneficially interested, directly or indirectly, in works executed, which is in contravention of section 11 of the Act. (b) To cases of wilful waste during the currency of the five years certificate, see section 47. (c) To the discretion which may be exercised before the order is made by the Bishop under section 34.

A CORRESPONDENT writes that the War has had an unfortunate effect upon the operations of builders and contractors and other firms who are in the habit of using the larger lengths of pitch-pine in the building trade, or in pile-driving. The larger bulks of pitch-pine come from the Mississippi and the Missouri, and owing to the War prices have advanced 6d. a foot—viz., from 1s. 8d. to 2s. 2d. It may be stated, however, that one good result of last year's Diamond Jubilee celebration was to increase the stock of this very useful timber in England, and most of the wood used for the erection of grand stands last June is now finding a ready market.

THE prize-list for the Department of Architecture and Building Construction of the Glasgow and West of Scotland Technical College, of which branch Professor Charles Gourlay, A.R.I.B.A., is the principal, is as follows:—I.—Architecture.—Junior Class.—First Class Certificates:—1, Colin Sinclair (prize); 2, John M. Arthur (prize); 3, James S. Boyd; 4, John Smith; 5, Julius Bradley; 6, Malcolm Black. Second Class Certificates:—7, Charles P. Barrett; 8, James A. Laird; 9, James Reid; 10, David Martin; 11, Daniel M'Ewan. II.—Architectural Design.—Junior Class.—First Class Certificates:—1, James S. Boyd (prize); 2, John M. Arthur (prize); 3, James A. Laird (prize); 4, John Smith. Second Class Certificate:—5, James Reid. Senior Class in Architecture and Architectural Design.—First Class Certificate and Prize: James M. Alexander. Glasgow Institute of Architects' Prize (value £2 2s.) for best set of sketches and measured drawings (summer work): Charles P. Barrett. III.—Building Construction.—In the first course, 25 first class certificates and prizes were awarded in order of merit to:—John Galt, Donald Grant, William B. Aird, John B. K. M'Taggart, Thomas Ritchie, Andrew Holmes, William M'Kechnie, Robert D. Clyde, William T. Whiteford, James Benwick, James M'Leod, and David C. Young. There were also 27 second class certificates. In the second course, 24 first class certificates were awarded, prizes being granted to James A. Ferguson, William F. Findlay, Robert Park, John Dunn, Alexander Wagstaff, Duncan Grant, and Alexander Craig, and also 21 second class certificates. In the third course, prizes were gained by James Gilmore, Robert B. Donald, James H. Mellis, and James Flett and David Skinner.

A MEETING of the Border builders was held in the Good Templar Hall, Galashiels, last week, to consider a proposal to form a company for the district to make provision for the increased responsibility of employers connected with the building trade by the Workmen's Compensation Act, which comes into operation on the 1st of July next. Mr. Adam Herbertson, Galashiels, presided, and explained that it was proposed to form a company with a capital of £1,000 in 1,000 shares of £1 each share, to carry with it a guarantee of £10, such guarantee to be called up, if necessary, for meeting claims for which the premium income and reserve and issued capital might be insufficient. It had been suggested that with a view to acquiring a substantial reserve fund a premium rate of 25s. per £100 in wages paid annual should be fixed at the outset, which, with experience, would be materially reduced. The maximum rate might be 25s., and the minimum rate 12s. 6d., and after payment of the higher premium for three years, firms which had had no accidents during that period might get off on payment of a reduced rate of 12s. 6d. He (Mr. Herbertson) had been in communication with Mr. Selkirk, secretary of the Ocean Accident and Guarantee Association, Limited, of London, who quoted rates for builders at 22s. 6d. per £100 of wages paid, and for some of the other branches of the trade the rates

were correspondingly low. That was for joiners. For saw millers the rates ranged from 25s. to 45s. If they were to avail themselves of these rates, however, they would require to form a branch of the Scottish Building Trades Federation, and he was opposed to having to do with more than one company; he, therefore, favoured the formation of a local company. Mr. Ruthven, plumber, Galashiels, said he heard that the Equitable Company had quoted the rate at 15s., and Bailie Lindsay, Galashiels, said he knew of another London company likely to fix the premium at 17s. He moved that a company be formed for the district, and that the question of rates and other details be left to a future meeting. Mr. Tweedie, plumber, Galashiels, seconded, and this was agreed to. The meeting seemed favourable to reducing the guarantee of £10 pertaining to each share to £5, being confident that this would be ample to meet the requirements of the district.

THE London County Council have adopted a recommendation of the Parks Committee to the effect that, as an experiment, and at a cost to the Technical Education Board, beds be planted in Battersea, Ravenscroft, and Victoria Parks with suitable specimen plants which could be utilised in the teaching of botany, and that a botanical guide be published. The object in view is to afford assistance to scholars at elementary and secondary schools in the study of practical botany. Presumably the same plan will be adopted as that at Kew—species of the different genera being arranged in beds.

From time to time, it has been proposed to protect buildings against fire from without by a water-curtain, to be made to fall all around the structure. This scheme is, says an American contemporary just to hand, being put in use at the Chicago Public Library. Mr. N. E. Weydert, supervising architect of the building, is father of the idea, and has received a hearty endorsement of it from Chief Swenie of the Chicago Fire Department. The arrangement is extremely simple. A 7in. steel water-main is being laid around the top of the building, upon the broad stone table formed by the top of the coping. This pipe will be connected to force-pumps in the basement of the building, and, through perforations properly arranged, will insure the introduction of a substantial sheet of water from cornice to pavement, around the whole or any imperilled portion of the building. The system of piping will be so arranged as to be operated in prescribed sections, and additional relays of smaller pipe will be placed in position above windows and doors, to complete the curtaining of those points, should the curtain, in the main, be broken by wind impingement against the building.

THE College of Architecture at Cornell University has followed the lead of Columbia and the University of Pennsylvania, in establishing an annual travelling fellowship in architecture of the value of two thousand dollars. The fellowship is restricted to graduates or special students, who have completed a two years' course, of the College of Architecture, and is to be awarded in competition. The holder is required to spend two years in advanced study, either at Cornell or in Europe, under the direction of the Faculty of the College. The same university also offers each year a graduate fellowship of the annual value of five hundred dollars. All graduates of schools of architecture of approved standing in the United States are eligible as candidates. The fellowship is awarded in June for the following year, and each candidate must submit drawings and other credentials, and file a formal application with the registrar of the university. Application forms may be obtained of Mr. D. F. Hoy, registrar, Ithaca, N.Y., and information relative to the fellowship is given by Professor A. B. Trowbridge, Ithaca, N.Y.

THE old-established firm of Messrs. J. Tyler and Sons is being converted into a limited company with a capital of £200,000, divided into 10,000 5 per cent. cumulative preference shares of £5 each, and 10,000 ordinary £5 shares. The vendors take 3,300 preference shares and 7,500 ordinary shares in part payment of the purchase money. The firm has been established over a century, it is undoubtedly the foremost sanitary business in the City of London, and its profits for the past 16 years abundantly warrant a good return to the investor. The subscription list opens on Tuesday next and closes on Thursday.

In the course of the discussion after the reading of his paper on "Water-gas" at the Society

of Arts, Prof. Vivian B. Lewes said that on the Continent the Dellwik process had the biggest future of any generator for making carburetted water-gas. There, water-gas as it is made in this country and in America, was practically an impossibility, because in Germany, France, and Belgium the price of oil, owing to duties and other factors, was so high that it was impossible to make carburetted water-gas to compete with coal-gas, by the improved Lowe process of breaking up the oil in superheated chambers so as to get oil-gas from it. What had to be done there was to make pure water-gas and carburet that by the products which the gas manager had at his disposal. Extended experiments made by Bunte and others showed that benzole was the most valuable enricher, and that was used by systems much akin to the Maxwell-Clerk type for enrichment on the Continent, and he heard that two of the biggest towns in Germany were adding to their gas supply in that way, large installations on the Dellwik principle being erected at Königsberg and Posen. They made it by the Dellwik generator, in the proportion of about one-third of the consumption, and, having mixed it with the ordinary coal-gas, they passed the mixture through benzole enrichers, and it formed an excellent illuminating gas. Therein lay the difference between that which was possible in England and that which was possible where they do not get cheap oil. The Dellwik process was, therefore, of enormous value to them. Here it had very small value for such purposes; it would only have a future if our oil supply were interfered with.

#### CHIPS.

Mr. Wm. Oxtoby, at present chief surveyor of Poplar, has been elected surveyor and engineer of the parish of Camberwell. There were 55 applications. The successful candidate is 36 years of age. He was article to Mr. J. Fox Sharp, borough engineer, Hull, from 1879 to 1883, and has since been borough surveyor of Beverley for two years, and of Ramsgate for three years, afterwards entering the service of the Poplar District Board of Works as chief surveyor.

A new church, seating some 600 people, and costing about £4,000, was dedicated on Tuesday by the Bishop of Winchester at Winton, a suburb of Bournemouth.

A considerable portion of the Congregational Chapel at Kingswood Hill, near Bristol, including the gallery, was destroyed by fire on Tuesday morning. The damage is estimated at over £1,000.

New oak seating has been placed in the body and south chapel of the fine Gothic church of St. Giles', Newcastle-under-Lyme, Staffs, at the cost of Mr. Edward Turner, who had previously given the oak pulpit and Communion rails, the clock in the tower, and had rehung the bells. The present gift was undertaken by him at a cost of £1,000, to commemorate the Queen's Diamond Jubilee. The work has been executed by Messrs. Jones and Willis, of Birmingham and London, from the designs of Mr. John Lewis, of Newcastle.

Mr. G. W. Willecocks, one of the inspectors of the Local Government Board, conducted an inquiry at Birmingham, on Tuesday, relative to an application by the corporation for power to borrow moneys amounting altogether to £33,010, for the purpose of carrying out various municipal works—£27,200 for street improvements, £4,610 for sewerage, £2,500 for the purchase of the leasehold interest in land for market purposes, £600 for payment to the Great Western Railway Company for the widening of Musgrave-road and Bacchus-road Bridges, £600 for the diversion and covering in of the Spark Brook, £500 for the provision of additional stabling at Harborne Wharf, and £2,000 for purposes in connection with the laying-out of Harborne Recreation Ground. There was no opposition to the various proposals.

At St. Joseph's Roman Catholic Church, Carrickmacross, a bell was formally blessed last week. It cost £200, and has been founded by Mr. Byrne, of Dublin.

On Friday Colonel Hepper, D.S.O., R.E., held a Local Government Board inquiry at the Davenport Arms, Calveley, with reference to an application of the Nantwich Rural District Council for sanction to borrow the sums of £1,700 and £1,550, for the purposes of carrying out works of water supply in the townships of Alpraham and Calveley.

At Dewsbury an arcade is about to be built extending from the Market-place to New Bridge-street. The buildings on either side will be of two stories, and at the entrances will be loftier premises. Messrs. Kale and Sons, of Dewsbury, are the architects.

#### MEETINGS FOR THE ENSUING WEEK.

SATURDAY (TO-MORROW).—Northern Architectural Association. Visits to Sandford Board Schools and the Grand Theatre, Raby-street Board Schools and Presbyterians Church, Heaton. Leave Grey Monument by brake at 2.30 p.m.

MONDAY.—Society of Arts. "Electric Traction," Cantor Lecture No. 4, by Professor C. A. Conrau Wilson, of McGill University, Montreal. 8 p.m.

Carpenters' Hall, London Wall, E.C. "Timber Roofs: Tie Beam and Hammer Beam," by John Slater, B.A., F.R.I.B.A. 7.30 p.m.

TUESDAY.—Society of Arts. "The Goldfields of British Columbia," by W. Hamilton Britton. 4.30 p.m.

THURSDAY.—Architectural Association. Annual Dinner, Holborn Restaurant. 7 for 7.30 p.m.

Society of Architects. Special meeting to consider alteration of Article of Association 11A; Lecture on "Library Construction and Arrangement" (illustrated by lantern slides), by C. Davis, librarian of Wandsworth Free Library. St. James's Hall, Piccadilly. 8 p.m.

## The Society of Architects.

Founded 1884. Incorporated 1893.

A GENERAL MEETING of the Society of Architects will be held at the Rooms of the Society, at St. James's Hall, Piccadilly, W., on THURSDAY, May 26th, 1898, at Eight o'clock p.m., when Mr. C. DAVIES, Chief Librarian of Wandsworth Free Public Library, will read a Paper on the subject of "LIBRARY CONSTRUCTION AND ARRANGEMENT," which will be illustrated by the lantern. ELLIS MARSLAND, Hon. Sec. MONTAGU BALDWIN, M.A., Sec.

#### CHIPS.

Major-General H. Darley Crozier, R.E., Local Government Board Inspector, held an inquiry at Deal last week into the application of the town council for sanction to borrow £36,350 for proposed works of sewerage.

Messrs. Douglas Young and Co. have sold the building estate at Norbury, comprising 59 acres, at the sum of £17,000. This disposes of four out of the five estates offered by this firm in the sale which aroused so much public interest in July last. The remainder of the West Worthing Estate is announced for sale on June 3.

Mr. E. A. Sandford Fawcett, A.M.I.C.E., an inspector of the Local Government Board, held an inquiry on Tuesday relative to the application of the corporation of Rotherham for sanction to borrow £4,000 for purposes of public baths. Ten years ago public baths were erected and a loan was obtained amounting to £4,100. Of this, there is still owing £3,654. Practically ever since the opening ceremony took place serious leakages have occurred, owing to the foundations having given way, and in repairs and additions no less than £3,345 have since been spent on the undertaking. One of the swimming-baths has now been demolished, and, in order to get sound foundations for the new structure, steel tubes 4ft. in diameter filled with concrete have been bored down to a depth of over 20ft.

The foundation-stone of a Primitive Methodist Mission-chapel and school was laid in Midland-road, Peterborough, on the 12th inst. The building is being erected at a cost of £650, from plans by Messrs. Kerridge and Sons, of Wisbech, the contractors being Messrs. Watson and Lucas, of Dogsthorpe-road, Peterborough.

At Monday's meeting of the rural district council of Cuckfield, it was announced that sanction had been received from the Local Government Board to the following loans for the purposes of water supply—viz., Ardingly, £6,615; Balcombe, £10,891; Bolney, £5,163; Cuckfield Rural, £10,758; Lindfield, £17,209; Slaugham, £9,364; total, £60,000. Sanction for the loan for the purchase of the water-works was also received.

The Bishop of Liverpool, on Saturday, opened the Clarke Memorial Schools, Southport, which have cost £6,600. The building occupies the site of the old schools, at the east end of the church, and its chief features are the large number of classrooms and a playground on the roof. By the removal of sliding and revolving partitions, a large hall can be formed on the first floor, capable of accommodating 800 persons.

Mr. D. W. Stevenson, R.S.A., of Edinburgh, has just modelled in the clay the colossal statue of Burns, for Leith. The figure, 9ft. in height, is firmly poised on the right foot, with the left slightly advanced. He wears the coat of the period, with open throat and ample collar and lapels; and his attire further consists of long waistcoat, knee-breeches, ribbed hose, shoes, and a plaid thrown over the left shoulder. The figure, which will be cast in bronze, will stand on pedestal 10ft. high.

# Trade News.

## WAGES MOVEMENTS.

**THE STATE OF THE LABOUR MARKET.**—The monthly memorandum for April prepared by the Labour Department reports that the state of employment is generally good, except in industries affected by the stoppage in the South Wales coal trade. In the 116 trade unions making returns, with an aggregate membership of 466,405, 13,546 (or 2.9 per cent.) were reported as unemployed at the end of April, compared with 3.1 per cent. at the end of March, and with 2.5 per cent. in the 114 unions, with a membership of 455,157, from which returns were received for April, 1897. Employment in the building trades is brisk, the percentage of unemployed union members being 1.1, compared with 1.6 in March and 1.0 per cent. in April, 1897. The furnishing trades remain busy. The percentage of unemployed union members at the end of April was 1.2, compared with 1.3 in March and 0.5 in April last year. Changes in the rates of wages of about 132,400 workpeople were reported during April, of which number 131,500 received advances, and 900 sustained decreases. The increases were mainly in the mining (113,895) and building trade (14,797) industries. The net result was an increase estimated at about 3s. 2d. per head in the weekly wages of those affected. Forty-four fresh disputes began in April, 1898, involving 130,523 workpeople, and of these no fewer than twenty took place in the building trades.

**CARPENTERS' AND JOINERS' WAGES INCREASED.**—The executive of the Amalgamated Society of Carpenters and Joiners, in their official monthly report, issued to the branches, which now number 738, state that lately a record of unprecedented successes in respect to the amicable and satisfactory settlement of the various trade movements has been established. The report further states that advances of wages have been conceded by employers as follows:—At Castleford, Coalville, Cromer, Colwyn Bay, Liverpool, Lynn, Lincoln, Mansfield, Preston, Rushden, Leeds, and Gravesend of ½d. per hour. At Birmingham an advance of ½d. per hour will come into effect next October. All overtime there, too, is to be paid for at the rate of time and a half. At Leicester a reduction of hours and increased payment for overtime, under the recommendation of the Board of Trade arbitrator, has been agreed upon; at Whitby an advance of 2s. weekly has been conceded. Alterations in hours have also been effected at Edinburgh, Leeds, Stockton, Carlisle, Maidstone, and Bournemouth.

**CHELLENHAM.**—Some time since a dispute arose in Cheltenham, between carpenters and their employers, as to the rate of wages to be paid, and the case was eventually submitted to arbitration. The men applied for an increase from 7d. to 7½d. per hour, on the grounds that stonemasons and plumbers received 7½d. and 7½d. respectively, that wages had been raised in other towns, and that there was a considerable demand for labour just now in Cheltenham. Against this it is pointed out that the masons lose time in bad weather, that plumbing is unhealthy, that the rate of wages in Gloucester, Bath, Torquay, and other similar towns is 7d., while in winter months Cheltenham hours are shorter. The case was submitted to the Rev. G. L. Gardner, vicar of All Saint's, whose award was that for the present the increase ought not to be granted, and that the wages of the carpenters and joiners should remain at 7d. an hour.

**MANCHESTER.**—The stonemasons have made a series of applications to their employers which include an alteration in the working hours and an addition to the rate of wages per hour. They also object to the employment of workmen on stone-dressing machines at the lower rate of wages than those paid to stonemasons, by whom the work was formerly done, and to the importation of worked or dressed stone into Manchester. A limitation of the number of apprentices is also proposed. The application will be resisted by the Employers' Federation, which includes a large number of contractors and builders in all the principal towns of Lancashire. A number of stonemasons, having previously sent in their notices, for operation in the event of a refusal by the employers to grant the alterations asked for, did not resume work on Monday.

**ROCHDALE.**—The strike of bricksetters' labourers in the Rochdale district has entirely collapsed; but there is no change in the situation as regards the strike of operative stonemasons.

**STOCKPORT.**—Nearly all building work at Stockport is at a standstill, owing to a dispute between the master builders and the bricklayers. For this reason the erection of the corporation electric lighting installation works at Millgate is temporarily stopped, and also the building of the district council offices at Levenshulme, a Stockport builder having the sub-contract. The question at issue is with the Operative Bricklayers' Association, and has reference to the various points from which the men are allowed "walking time" to the buildings where

they are employed. In Manchester the radius is two miles from the Exchange. The Stockport employers contend that under their propositions the radius would be not more than a mile and a mile and a half from the centre of the town, and that a recent advance in the wages of the bricklayers was accompanied by a tacit understanding that the boundaries would be extended, in proof of which assertion it is pointed out that the joiners, masons, and painters have accepted the new boundaries. The old "walking places" have been observed for 25 years, and the bricklayers decline to accept any alteration in the most important routes north and south. An advertisement for men has failed to bring the employers the desired relief, owing to the briskness of the building trade in all surrounding districts.

**TYNESIDE.**—There is a general movement in the building trades on Tyneside for advances of wages. With regard to the joiners, mill sawyers, woodcutters, and machinists, application was made for the whole Tyne District, including Blyth and North and South Shields. The employers of Newcastle, Gateshead, and South Shields offered ½d. per hour advance, which was officially accepted on Friday. It is expected that Blyth and North Shields employers will come in line, and so avoid the threatened rupture.

**WESTON-SUPER-MARE.**—The master builders having withdrawn their demand with respect to the alteration of the working rules of the Amalgamated Society of Carpenters and Joiners, and having signed the rules as submitted, the men resumed work on Monday.

## CHIPS.

Plans have been prepared for large additions to the Wilts County Council offices on the Parade at Trowbridge, involving an expenditure of about £6,000.

On Saturday the members of the Birmingham Clerks of Works and Builders' Foremen's Association were conducted over the new Hen and Chickens Hotel, New-street, in that city, by Mr. John Moffat, the builder.

Viscount Portman opened, on Friday, the Morley Hall and Gymnasium, George-street, Hanover-square. The hall, which cost £4,000, is the gift of Mr. Howard Morley and a memorial of Mr. Samuel Morley, and is an addition to the premises of the Young Women's Christian Association, purchased some time ago at a cost of £24,000.

The town council of Haddington decided, on Monday, to instruct Messrs. Belfrage and Carfrae, civil engineers, of Edinburgh, to prepare working drawings and specifications for a new bridge over the river at the end of Market-street.

Colonel Marsh, R.E., an inspector from the Local Government Board, held an inquiry at Southampton on Wednesday into an application for leave to borrow £28,428 for water supply, £500 shed accommodation at the corporation wharf, £380 for the purchase of the steam roller, £300 for filter-beds at the corporation baths, and £125 for street improvements.

A new suburban railway-station, to be known as St. Anne's Park, is to be opened at Brislington, Bristol, by the Great Western Railway Company on Monday next. The contractor was Mr. S. Robertson, of Bristol.

The Eastbourne light railway scheme, which was intended to have opened up the district between Eastbourne and Seaford, was rejected by the commissioners on Saturday.

It is proposed to restore the parish church of Dibden, Hants, from plans prepared by Mr. Percy G. Stone, F.R.I.B.A.

To celebrate the enlargement of the Lamberhurst Brewery to double its original capacity, a company were entertained to dinner on Tuesday week by the proprietors, Messrs. Smith, in the Brewery Hall. The enlarged building has been practically rebuilt and re-equipped. Mr. Louis Beale, of Tunbridge Wells, was the contractor, and the engineer was Mr. R. W. Andrews, of High Holborn.

# SZERELMEY STONE LIQUID.

## THE TEST OF TIME.

Over Forty Years' General Experience has proved that

# SZERELMEY STONE LIQUID,

Absolutely Waterproofs and Preserves BRICKS, STONE, CEMENT, PLASTER, STUCCO, &c.

Adopted by Governments and Public Bodies throughout the world.

SZERELMEY & CO., ROTHERHITHE NEW RD., S.E.

# LATEST PRICES.

IRON, &c.		Per ton.	Per ton.
Rolled-Iron Joists, Belgian.....	£6 0 0	to	£8 10 0
Rolled-Steel Joists, English.....	6 10 0	"	7 0 0
Wrought-Iron Girder Plates.....	5 15 0	"	6 10 0
Bar Iron, good Staffs.....	7 0 0	"	8 0 0
Do., Lowmoor, Flat, Round, or Square.....	17 0 0	"	17 5 0
Do., Welsh.....	5 15 0	"	5 17 6
Boiler Plates, Iron—			
South Staffs.....	7 17 6	"	8 5 0
Best Sneedhill.....	10 0 0	"	10 10 0
Angles 10s., Tees 20s. per ton extra.			
Builders' Hoop Iron, for bonding, &c., 26 15s. 0d. per ton.			
Builders' Hoop Iron, galvanised, 25 10s. 0d. per ton.			
Galvanised Corrugated Sheet Iron—			
No. 18 to 20.		No. 22 to 24.	
6ft. to 8ft. long, inclusive gauge.....	£10 15 0	Per ton.	£11 0 0
Best ditto.....	11 5 0	"	11 10 0
Cast-Iron Columns.....	£8 0 0	to	£8 10 0
Cast-Iron Stanchions.....	6 0 0	"	8 10 0
Rolled-Iron Fencing Wire.....	7 0 0	"	8 0 0
Rolled-Steel Fencing Wire.....	7 6 0	"	7 10 0
Galvanised.....	10 10 0	"	11 10 0
Cast-Iron Sash Weights.....	4 0 0	"	4 2 6
Cast-Iron Socket Pipes—			
3in. diameter.....	5 10 0	"	5 15 0
4in. to 6in.....	5 5 0	"	5 10 0
7in. to 24in. (all sizes).....	4 15 0	"	5 0 0
[Coated with composition, 2s. 6d. per ton extra; turned and bored joints, 6s. per ton extra.]			
Pig Iron—		Per ton.	
Cold Blast, Lilleshall.....	105s.	to	110s.
Hot Blast, ditto.....	57s. 8d.	to	62s. 8d.
Wrought-Iron Tubes—Discount off Standard Lists f.o.b.			
Gas-Tubes.....	75p.c.	Fittings 77½p.c.	
Water-Tubes.....	70	"	72½
Steam-Tubes.....	62½	"	65
Galvanised Gas-Tubes.....	60	"	62½
Galvanised Water-Tubes.....	55	"	57½
Galvanised Steam-Tubes.....	45	"	47½
10cwt. casks. 5cwt. casks.			
Sheet Zinc, for roofing and working up.....	£22 15 0	to	£23 0 0
Sheet Lead, 3lb. per sq. ft. super.....	15 10 0	"	16 10 0
Pig Lead, in 1cwt. pigs.....	14 12 6	"	15 12 6
Lead Shot, in 28lb. bags.....	17 10 0	"	18 10 0
Copper Sheets, sheathing and rods.....	64 0 0	"	65 0 0
Copper, British Cake and Ingot.....	51 15 0	"	52 15 0
Tin, Straits.....	65 18 9	"	66 8 9
Do., English Ingots.....	68 10 0	"	68 15 0
Spelter, Silesian.....	17 17 6	"	18 17 6
Cut Clasp Nails, 3in. to 6in.....	8 15 0	"	9 15 0
Cut Floor Brads.....	8 10 0	"	9 10 0
Wire Nails (Points de Paris)—			
0 to 7 8 9 10 11 12 13 14 15 B.W.G.			
8/6 9/0 9/6 10/3 11/0 12/0 13/0 14/9 16/9			per cwt.
<b>TIMBER.</b>			
Teak, Burmah.....per load	£13 0 0	to	£14 5 0
Bangkok.....	9 0 0	"	14 0 0
Quebec pine, yellow.....	2 5 0	"	4 5 0
Oak.....	3 15 0	"	5 0 0
Birch.....	2 16 0	"	4 7 6
Elm.....	4 0 0	"	5 0 0
Ash.....	3 5 0	"	4 10 0
Dantsic and Memel Oak.....	2 2 0	"	3 2 0
Fir.....	1 4 0	"	3 4 0
Waincoat, Riga p. log.....	5 0 0	"	6 10 0
Lath, Dantsic, p.f.....	4 10 0	"	5 10 0
St. Petersburg.....	5 0 0	"	6 10 0
Greenheart.....	8 0 0	"	8 10 0
Box.....	4 0 0	"	15 0 0
Sequoia, U.S.A. ...per cube foot	0 1 8	"	0 1 10
Mahogany, Cuba, per super foot			
lin. thick.....	0 0 5	"	0 0 6½
Honduras.....	0 0 4½	"	0 0 6½
Mexican.....	0 0 4	"	0 0 5
Cedar, Cuba.....	0 0 4	"	0 0 4½
Honduras.....	0 0 3½	"	0 0 4½
Satinwood.....	0 0 5	"	0 1 0
Walnut, Italian.....	0 0 3	"	0 0 7
Deals, per St. Petersburg Standard, 120—12ft. by 1½in. by 1½in.—			
Quebec, Pine, 1st.....	£19 5 0	to	£25 5 0
" 2nd.....	13 15 0	"	16 5 0
" 3rd.....	6 5 0	"	9 15 0
Canada Spruce, 1st.....	10 10 0	"	12 0 0
2nd and 3rd.....	5 5 0	"	9 15 0
New Brunswick.....	7 0 0	"	8 0 0
Riga.....	6 15 0	"	7 15 0
St. Petersburg.....	8 15 0	"	12 15 0
Swedish.....	9 0 0	"	15 15 0
Finland.....	8 5 0	"	8 15 0
White Sea.....	9 15 0	"	16 0 0
Battens, all sorts.....	5 5 0	"	18 0 0
Flooring Boards, per square of lin.—			
1st prepared.....	£0 9 6	"	£0 17 9
2nd ditto.....	0 8 0	"	0 13 6
Other qualities.....	0 6 0	"	0 7 6
Staves, per standard M:—			
Quebec pipe.....			
U.S. ditto.....	£85 0 0	"	£42 10 0
Memel, cr. pipe.....	225 0 0	"	230 0 0
Memel, brack.....	190 0 0	"	203 0 0
<b>OILS.</b>			
Linseed.....per ton	£17 0 0	to	£19 12 6
Rapeseed, English pale.....	24 7 6	"	24 10 0
Do., brown.....	23 0 0	"	23 10 0
Cottonseed, refined.....	16 5 0	"	16 15 0
Olive, Spanish.....	32 10 0	"	33 0 0
Seal, pale.....	22 0 0	"	22 5 0
Cocconut, Cochin.....	28 0 0	"	29 0 0
Do., Ceylon.....	22 10 0	"	23 0 0
Palm, Lagos.....	23 5 0	"	23 10 0
Oleine.....	18 15 0	"	19 15 0
Lubricating U.S.....per gal.	0 6 3	"	0 7 6
Petroleum, refined.....	0 0 4½	"	0 0 4½
Tar, Stockholm.....per barrel	1 0 0	"	1 5 0
Do., Archangel.....	0 12 6	"	0 15 0
Turpentine, American... per ton	23 15 0	"	24 0 0

# THE BUILDING NEWS

AND ENGINEERING JOURNAL.

VOL. LXXIV.—No. 2264.

FRIDAY, MAY 27, 1898.

## NATURAL ART.

THE art of concealment makes a large demand on the architect of to-day. The old and trite adage *Ars celare artem* has not yet been learned by those who deal in architectural style—they are for ever trying to show and display their art instead of concealing it. Only true art genius has ever been able to make art natural. Instead of concealing the methods and results of art, the modern professor is for ever trying to make the most of what he has learned. Instead of concealing art and treating his materials naturally, he just reverses the process—he exhibits the formula of his knowledge by disguising or counterfeiting his materials. Modern architecture is largely an art of semblances, of representing types and patterns, of appearing to be something that it is not. Evidences of the most expensive materials and elaborate workmanship are put forward for which there is not the slightest foundation.

Seeming that which is not is one of the commonest weaknesses of modern architectural work. At one period there was no difficulty in tracing to its origin the motive of any particular design—everything was plain and outspoken: the column expressed support, the arch economy of construction, and every little detail had a meaning at once direct and expressive. It is far from being the case now. Modern resources have opened to us numerous temptations in the way of materials and methods of construction at once tractable and dishonest. We are tempted to use even granite and marble, in a manner quite unreal and defiant of their very nature and properties, as mere slabs and veneers for casing our iron supports; artificial stone and concrete are turned into all kinds of semblances to stone construction. Many plastic substances are applied to represent almost anything: textiles, carving, metal and stone work, besides the legitimate uses to which they ought to be applied. The limitation of materials and all that the term implies is entirely ignored. Again, when we can rear gigantic façades of any style on plate-glass windows or fragile metal columns, it is not easy to see where we are to stop in this factitious and unreal progress. When a few pieces of iron or steel can be so arranged as to carry almost any weight, or erected as a skeleton structure that can be clothed with thin materials or slabs, the temptation is strong to employ the features and details of a masonry architecture, and thus we see in the streets of New York, Chicago, and other cities of the West lofty tenement houses posing as palaces or Italian campanili, designs suitable only for stone or marble—mere skin-deep representations of solid building. Can we be surprised if the same unreality has appeared on this side of the Atlantic? We are not speaking of those who are working on a higher plane, who have come to realise what art in building means, and how it should be applied to our everyday wants, but of the ordinary modern building and its pretence to architecture we see in our streets. We see this pretentiousness unblushingly manifested in large business premises, in our new hotels and restaurants, where everything assumes to be of the costliest and most sumptuous description, and where the appearance of labour is courted in every detail, from the counter or bar and its accessory furniture to the walls and ceilings. Nothing can be too elaborate or decorative

for these buildings. A lavishness of display in carving, turning, fretwork, modelled ceilings, coloured glass, mirrors, polished metal, and painted enrichments meets us at every turn. But what is it all worth? The most superficial glance is enough to convince the expert eye of the fraud. If it is a piece of ornament on the top of a screen, or a buffet sideboard full of curves and scrolls, or bristling with finials, we perceive at once that it has all been done by the lathe or the fret-saw, or patterns are cut in half and reversed. The ostensible hand-carved work turns out to be only composition or embossed work stuck on to the surface of the wood, the profusely-carved stone capital is cast work put up in pieces, or, if really carved, it is a mere slab of stone fixed round the top of a cased stanchion. The fraud does not stop at the fittings: it extends to the architecture of the interior. The floor, walls, and ceiling proclaim the lie. They are all covered with something that represents a more costly material than wood or brick or plaster; but, not content with display of costly material, they are also treated in a manner no mason or carver of any repute would tolerate. And it is this fraud upon fraud, this redundant and profuse ornamentation, which shocks the feeling of propriety and common sense. Moderation seems to be impossible after certain limits are past; all is license of that baneful pernicious kind which ran riot during the excesses of the art of the French Rococo or Louis XIV. style, and which closed in the revolt that followed under the Empire. And is this not the end of all unrestraint, political as well as artistic? History repeats itself; the same lesson is enforced and has to be learned again every age. We have examples everywhere. We can appeal to any great period for evidence of naturalness.

Formulas, it has been justly said, are good to exhibit the knowledge of him who gives them; but they are useless to the practical worker who allows himself to be directed by his instinct or his experience. Forgetfulness of this fact has led to our present absurd position of adopting the formulas of systems of building which are now defunct. So it has been with those who have been reproducing Greek, Renaissance, and Gothic on all occasions in our time, without so much as once reverting to the principles the old builders were actuated by. Viollet le Duc, in his admirable article on Construction, in the *Dictionnaire Raisonné de l'Architecture Française*, makes many excellent remarks that may be usefully considered in this connection. Speaking of the spirit and principles which actuated the old Gothic builders and those modern followers of the art in his time who have gone so far astray as to make very ridiculous applications of Gothic, he invites us to consider the principles, instead of the traditions or formulas which underlie the Gothic. That great system, he observes, is the safest initiation into modern art, if we only work on the principles on which it was based. It had broken with antique traditions. It matters little, he says, whether a bell-tower be covered with ornaments which are not to the taste of such and such a school, if this bell-tower have a reason for its existence, if its function is necessary, if it permit us to take up less room on the public way. Beauty is not, in an art, wholly conventional and logical, linked for ever to one single form; it can always reside there when the form is but the expression of satisfied need, of judicious use of material. Because the multitude sees in Gothic architecture only its ornamentation, and because this ornamentation no longer belongs to our time—is this a proof that the construction of these edifices can no longer find an application? One might, he says, just as well maintain that a treatise on geometry is worth nothing because it is printed in Gothic characters, and that the students reading any theorem are learning mere folly, and are being misled; and he

goes on to show that Gothic construction is not like the Classic, immutable and absolute, but is as free and inquiring as the modern spirit. The builders of those times were not baffled by routine, by exclusive dogmas, or systems. And so it may be now, if only we could learn to be more honest to ourselves and our requirements. We shall never do much till we have learnt to be natural with our materials. Technical education in building trades will never teach us by the employment of mere conventions. The teaching of youths to design palaces and cathedrals according to historic precedents or formulas is like teaching them to become poets by copying Chaucer's style; instructing a boy to make a cardboard model of Canterbury Cathedral or the Parthenon only makes him an adept as a mimic. The modern architect has much to fight against—machine tools, mechanical labour, past traditions in his profession—all influences which serve to perpetuate the cut-and-dried methods of art, and the loss of that directness of method which distinguished the early work. Easy reproduction by mechanical means is more favourable to the large capitalist and manufacturer than executing work by the hand in a direct and simple manner; added to which is the desire to give the appearance of labour at the least cost. These are the incentives to the substitution of artificial for natural art and honest intentions.

## MODEL SPECIFICATIONS.—XIV.

MASON.

WE add to our former notes a few considerations. In specifying mason's work, some acquaintance with the measuring of stonework is essential, and, indeed, up to a certain point, the most efficient specification writer is he who knows how quantities are taken out or work is measured, and for this purpose we recommend the student to consult the admirable works of Mr. John Leaning, Professor Banister Fletcher, and others. The methods of measuring stonework vary. That usually adopted in London is to take out all the labours upon it—a practice that has much to commend it, but which does not appear to be taken advantage of by builders in making their estimates. By others, labour on beds and joints are omitted, and the stone is described as including "all plain beds and joints and preliminary faces," the other labours being added. Mr. Leaning says a reasonable average of beds and joints to each cubic foot of stone is, in Classic and Renaissance work,  $1\frac{1}{2}$  superficial feet, in Gothic work 2 superficial feet. The specifier of mason's work should be able to describe the labours on the stone—how it is to be worked, so that the quantities may be correctly taken. A good practice is to give sketches of special features and details of stonework or the more ornamental parts, by which the builder can see the kind of labour which each includes, and this plan, we believe, assists the estimator more than the ordinary descriptive clauses do. Thus in sunk work or moulded work it is necessary to give a sketch to show the face or girth of mouldings sunk; a capital or base, panels, corbels, finials, bosses, &c., are better described by sketches.

In specifying ashlar work, the average thickness and height of the stones ought to be described; as, for example, the alternate courses to be 9in. and 4½in. on bed and 12in. high; also the average length of bond-stones, their width and height, and how often they are to occur to the superficial yard, the finished face of stone, whether tooled, rubbed, or dragged, and if there are any cuttings, fitting to dressings, mortises, dowels, &c.

We have given sketches of several kinds of joints. Grooved and tongued or joggle joints are used for jointing landings. The joggle

## FAIENCE DECORATION

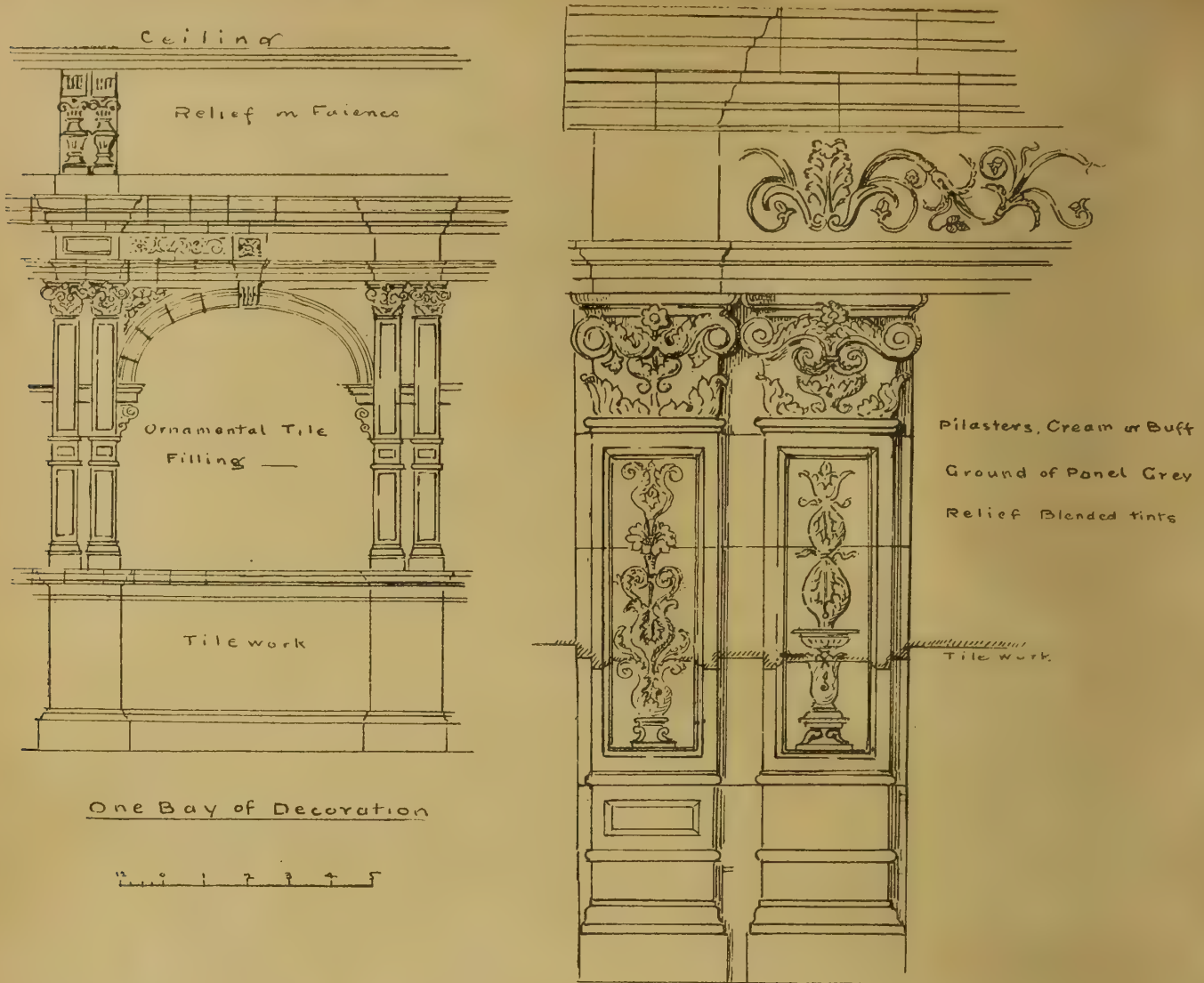

joint worked in the solid stone, *b*, p. 697, is not so strong as the metal tongue. Those we illustrate herewith show other forms of cramps or dowels. A cramp of copper or bronze run in with lead or sulphur into a groove worked on adjoining ends of the stones is shown at *a*; another form dovetailed is let into a corresponding groove, it may be of slate or metal. In jointing stones like cornices, curbs, arch-stones, and the like, cement or lead plugs, *c*, are used, grooves being cut at the ends of the two stones with dovetailed holes, into which the lead is run. In the construction of stone lintels or architraves, it is usual to make the centre stone a kind of "key" with concealed joints (see Fig. 10, p. 697). The joints are formed as shown, by two radiating joggles with corresponding indents, or recesses, the joggles being made in the keystone. By this means the outside vertical joints are preserved. Our sketch *d* shows how this is formed in a lintel.

There are many varieties of rubble walling. We illustrate rubble ashlar, *e*, or a rubble wall faced with ashlar; ashlar with brick backing, *f*; and then we have uncoursed random rubble, *g*, where the stones are irregular in size and shape just as they come from the quarry, and rough on the face. In a stone district where only hard stones are obtainable this kind of wall is used. It should be built quite one half thicker than the usual brick wall. In the next class of rubble work, called "coursed random rubble," the stones are irregular in size and shape, but are built in courses roughly formed. "Irregular coursed rubble," *i*, describes stones irregular in size and rough-faced, two or three deep, set in courses, or of the whole

depth between two courses. There is also "regular coursed rubble," a wall with roughly faced stones laid in courses of varying height, roughly squared and of different lengths, each course being on one level—a sort of rough "random ashlar." "Kentish rag" walling is built in one of these modes. The joints are important. They may be in lime, stone-dust (or white-lead) putty  $\frac{3}{4}$  in. from face, for ashlar work, or be raked out and pointed with cement or lime mortar, or blue ash, and tuck-pointed in lime, or tuck-pointed in cement, as in Kentish-rag work and other rubble walls.

Certain hard stones are used for thresholds, copings, sills, pavings, steps, templates, &c. "Hard York" is the most used for these purposes. For a superior class of work "Robin Hood York" may be used, or Portland stone.

(Previous sketches for terracotta work, with a slight diversity in jointing, will illustrate stonework. Our sketch to-day is for faience decoration. The clauses for terracotta are suitable. Doulton's, Lambeth; or Burman-tofts, Leeds; Minton, Hollins and Co.; Edwards, Ruabon, are manufacturers of faience decoration.)

Having described ashlar facing, on p. 698, we append clauses for rubble walling. State the quarry required, how the stones are to be laid, height of courses, whether in mortar or cement, bond-stones to every yard square, and footings.

7. *Uncoursed Random Rubble.*—The stones to be from — quarry free from sand or clay holes, irregular in shape, and as found in the quarry, or hammer-dressed, laid in mortar, the joints raked out and pointed with blue ash mortar. A

through-stone to every yard superficial. The quoins to have a rock or hammer-dressed face, with a chiselled draft on each return of angle. Or—

8. *Coursed Rubble.*—The stones to be from — quarry, free from sand or clay-holes, and irregular in shape, roughly dressed on face, built in rough courses 12 in. (or 15 in.) high. The quoins to be hammer-dressed, with a chiselled draft at the return sides of angle. The courses to be laid in mortar, raked out and pointed with blue-ash mortar, or tuck pointed in cement. The bond-stones not less than 12 in. by 8 in. on face, to be built in every superficial yard. The footings to be 12 in. high, projecting 3 in. on each side, and to be formed of all through-stones. Or—

9. *Random Coursed Facing.*—The exterior of walls to be finished in random coursed work, the stones hammer-dressed to a fair surface, with neat joint, and well pointed. Proper headers and bond-stones to be inserted every alternate course, and the work to be grouted with hot lime and sand every two courses. The stones to be bedded as found in the quarry. Or—

The stone to be Kentish rag (or other local stone of hard quality), and the walls are to be built with random coursed rubble, hammer-dressed, from 4 in. to 8 in. deep, with a through-stone to every superficial yard, laid in mortar, raked out, and pointed with blue-ash mortar.

10. *Regular Coursed Facing.*—The exterior walls above ground to be faced in neat and regular coursed work; no course to be more than 9 in. nor less than 6 in. high, hammer-dressed on face, the joints to be close and true, and pointed with lime mortar (or Aberthaw mortar).

11. *Coursed Ashlar.*—The exterior walls (or front) to be faced with neatly trimmed rubbed ashlar of Portland (or Corsehill, or Box Ground stone) in courses of equal (or varying height), not more than 15 in., nor less than 9 in. The vertical joints to be tooled, and the horizontal joints bevelled 1 in. deep, so as to throw off the water, and pointed with cement mortar.



Joints

MASONS WORK

Walls - Ashlar & Rubble

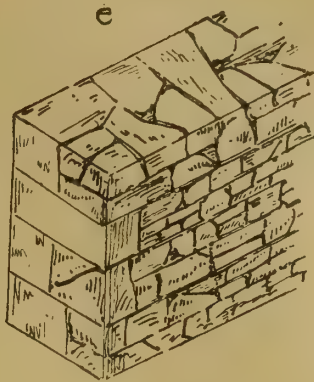
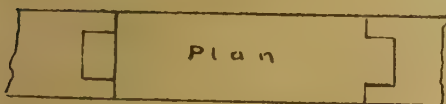
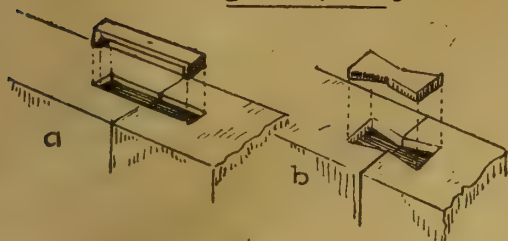

Uncoursed  
Random  
Rubble



Random Rubble  
in courses

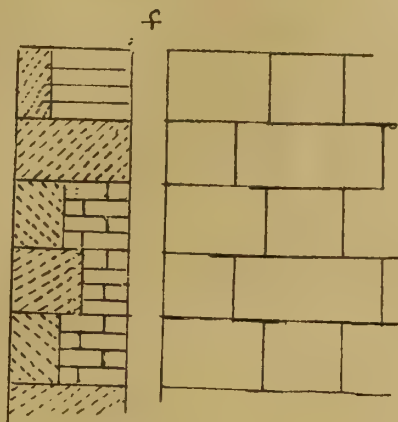

Coursed Ashlar

Stones of the same height



Irregular  
Coursed Rubble

The following items are of general application, and hard Yorkshire, "Robin Hood," Scotgate Ash, and other hard stone is used, though for a superior class of work, Portland stone from the "Whit-bed" series may be specified.

12. *Corbelling*.—Supply where required 3in. (or 4in.) hard, tooled York stones, to carry oriels, chimney-breasts, and angle fireplaces, and other projecting structures. The stones to be in layers or corbelled out where required to support heavy structures, and well pinned into wall with slate in cement. The projecting oriels to be carried on 4in. hard York landing (state size) in one or more pieces, cut and pinned into wall in cement (or tailed under an iron joist if there is little weight of brickwork over.)
13. *Templates*.—All iron girders, tie-beams, iron joists to concrete floors to be laid on hard York tooled templates, 3in. (or 4in.) thick in cement. The seating for girders, &c., to be 4lb. lead or asphaltic felt.
14. *Cover Stones*.—Over the iron girder or timber beams carrying walls hard 3in. York stones to be placed, of the full thickness, and of a length not less than 4ft.; the joints to be cramped with copper cramps. On the upper flange of riveted girders a layer of cement is to be put before the stones are imbedded, to give a flat bed above the rivet-heads.
15. *Thresholds*.—To all outside doorways put 3in. tooled (or rubbed) hard York thresholds, back jointed, and 1½ wider than wall, mortised for dowels or stubs of door-frame. These thresholds to be kept an inch or 1½in. above the floor. Or—Put to all external doors 6in. rubbed Portland stone (Robin Hood or Caithness stone) steps, weathered, and back jointed, mortised for dowels, and fixed 1½in. higher than the floor level.
16. *Bases for Iron Columns*.—Put hard York (Scotgate Ash) tooled (or rubbed) stone bases (specify size and height) under all the iron columns. The bed to be tooled even and true, and set in cement on the concrete footing. (Sometimes four bolts to hold down base-plate of iron column are used, in which case, holes of 1in. or 1½in. must be

drilled.) Put a Yorkshire (or Portland) stone base tooled (or rubbed) to every column (specifying size), with mortises for stubs. Or—

Put to door-frames hard tooled York stone bases, 12in. deep and 1½in. wider each way than the frame, chamfered at top all round, and mortised for dowels.

17. *Steps*.—Put to all external doors 3in. or 6in. tooled (or rubbed) York (or Portland) stone, weathered and back-jointed York steps 1½in. wider than the thickness of walls, and kept 1½in. above floor level, mortised for dowels. Or—

Put to all openings where tile paving is used 9in. by 3in. rubbed Yorkshire (or Portland stone) thresholds equal to thickness of walls.

18. *Curbs*.—The area walls to be coped with 9in. by 6in. tooled (or rubbed) hard York stone, chamfered on top edges (or rounded), with slate or copper dowels, the ends built into walls 6in., bedded and jointed in cement. Mortise top for iron railing with York spurs every 8ft. (or 10ft.) apart, projecting 12in. The spurs to be placed on York corbels built into wall. Double tile creasing or slate weatherings in cement, to be fixed under curb to throw off water from face of wall.

19. *Hearths*.—Put to all fireplace openings 2in. or 2½in. rubbed York stone hearths, back-jointed and cut for chimney-piece. The front hearth to be 18in. in width, and 18in. longer than opening; the hearths to be bedded on cement concrete. Or—

Put to all fireplace openings 2½in. rubbed Portland stone hearths (where coloured blue on plan) set in cement, each hearth to be back-jointed and notched for chimney-piece, and to be 18in. longer than the opening. The kitchen fireplace to have a 2½in. rubbed Yorkshire stone hearth, 2ft. wide, and 18in. longer than chimney opening, well bedded in cement concrete.

20. *Paving*.—Pave the area with 2in. tooled York paving, bedded and jointed in mortar in straight courses breaking joint. Or—

Pave the kitchen, scullery, and basement with 2½ (or 3in.) tooled or rubbed York stone, laid in parallel courses, bedded in mortar on concrete (or brick sleeper walls), pointed in cement.

CHEAP PAINTS AND PIGMENTS.—II.

(Concluded from p. 510.)

**CHROME-GREENS**—such as are used in house-painting—consist of mixtures of chrome yellows and Prussian blues in varying proportions. Such greens are usually sold under the name of Brunswick green. Originally, however, Brunswick green was obtained from salts of copper; but very little of that original pigment is made and sold now, as similar tones of colour can be obtained at a much cheaper rate by means of mixtures of blue and yellow pigments. Such mixture is made in two ways—either by mixing the dry pigments together in powder, or else by simultaneously precipitating the yellow and blue pigments. By the latter method a much better and more uniform admixture of the yellow and blue particles is produced than by mixing the dry powder colours. The process by mixture in the dry way is to sift blue and yellow pigments together several times through a sieve, and then put the mixture under an edge-runner mill. Any adulterating body—such as barytes, chalk, kaolin, &c.—is mixed in with the yellow and blue pigments at the time of sifting. It is conceivable that by this method it is not always possible to intimately mix every particle, no matter how long the mixing process may occupy. There is one advantage in this method over the wet process—namely, that when the mixing is done the compound is ready for use in grinding up in oil, whereas in the wet method the compound pigment has to be washed and dried and then ground in the dry state before being able to be mixed with the oil. By the wet method the green pigment is produced thus:—Two wooden tubs or vats stand on a shelf, each fitted with a tap that permits the fluid contents of each vat to flow into a larger one standing below the shelf. Into these vats are put a solution of bichromate or chromate of potash or soda (according to the tone of green to be produced), and a solution of ferro-cyanide of potassium (yellow prussiate), each solution

having been made in a separate vessel, and strained or filtered before putting it into the vessel standing on the shelf. In the large vat that stands below these two vessels is put solutions of lead and iron salts, together with any white body that is to be admixed for the express purpose of increasing the weight, bulk, or rendering the tone of colour light. The contents of this large vat are kept continually stirred while the taps of the vessels standing on the shelf are opened to allow of the fluid contents to be discharged into the larger vat below; then the solution of bichromate of potash, &c., when it comes in contact with the solution of lead salt in the vat below (which is either a solution of acetate or nitrate of lead) will produce yellow chromate of lead; similarly, when the solution of yellow prussiate comes in contact with the solution of iron salt that is in the large vat (usually a solution of sulphate, but sometimes one of nitrate of iron) there will be a production of Prussian blue; consequently, as the yellow and blue pigments are produced simultaneously, their particles will be most intimately commingled, as likewise will the solid white particles of the adulterating body (barytes, gypsum, kaolin, &c.) that is being stirred up in the large vat. When the whole of the solutions are mixed together in the large vat, the contents of the latter are allowed to settle, the supernatant liquor drawn off, and fresh water run in, the contents stirred up and again allowed to settle, when that wash water is drawn off and a fresh quantity added, and the stirring and settling repeated *de novo* until the pigment is sufficiently washed free of soluble salt. The pulpy mass of green pigment is then taken out and dried by one of the usual methods adopted for drying pigment.

There are many formulæ as regards the respective quantities of each particular ingredient to use, each colour-maker adopting his own. It will be seen from this method of mixing that the amount and nature of the adulterant mixed with the green can be also varied at the will of the maker. If sulphates of iron be the iron salt that is used, Prussian blue itself will not be at once formed on the mixing therewith of the yellow prussiate, but a whitish, greenish mass, which by means of a supply of oxygen is converted into the deep blue pigment. This greenish-white mass is oxidised either by exposing it to the air for some time with frequent stirring—a long and tedious process—or else by the addition of some oxidising agent, such as sulphuric or hydrochloric acid, the nature of this oxidising agent being determined according to the other ingredients that have been used. To produce a bright colour, it is necessary to preserve the contents of the large receiving vat of an acid nature, for if allowed to become alkaline, such alkalinity will affect the brightness of the yellow chromate of lead by changing it more or less to a brown. It is usual to add a little sulphuric acid to the solution of yellow prussiate in a small vessel. In the case of using nitrate of lead and other *per*-salts of iron, the deep blue coloured pigment is produced at once on such solution coming in contact with the yellow prussiate. Of course, there are various modifications of the above process, but that given is a general outline sufficient for the reader to form an accurate idea of how Brunswick or chrome-green pigments are made, and in what way adulterated.

The true chrome-greens—*i.e.*, those which are obtained from chromium and chromium salts—are usually produced by fusing the components in crucibles in the heart of a reverberatory furnace; but as these green colours are limited in tone, expensive, and, therefore, very little used in house-painting, further mention of them is unnecessary.

Under various fanciful names, however, there are a lot of greens sold. Thus, *Brighton Green* is a compound obtained by compounding solutions of sulphate of copper and sugar of lead with water in which whitening is stirred up.

*Bremen Green* is made on the same principle as blue verdite. It is essentially a copper green.

*Cobalt Green*, sometimes called zinc green, is obtained by the calcination of a mixture of oxide of zinc and cobalt. This green is a very pale light green, something like emerald green in tone, but more bluish. It is a more permanent green than emerald green, but its price renders it unfit for general use in common painting, particularly so as its tone and colour can be well imitated by emerald green, blue and white pigments.

*Douglas Green* is a pigment obtained from the decomposition of chromate of barium. The green

is a very pale, light green, and not very satisfactory in colour or working qualities.

*Emerald Green* is a compound of copper and arsenic salts. All pigments obtained from copper or arsenic salts are liable to darken in time, and suffer decomposition by sulphur and mixture with other pigments. Emerald green is such a light, pale green of a pure green tint that it cannot be imitated by mixture of yellow or blue pigments. It is very different in body or opacity, and works granular under the brush. Owing to the volatility of arsenic under alternations of temperature, the poisonous component becomes partially separated, and, mixing with the air of the apartment, sets up blood-poisoning in all persons inhabiting such rooms. On this account emerald green has long been condemned as a painter's colour. If it be ground up in a varnish vehicle, however, such poisonous emanations would not take place, and consequently it could be safely used. Paris green is only another name for a pigment similar to emerald green.

*Manganese Green* is more of a chemical curiosity than a commercial pigment; but it is a good, permanent green, and worthy of attention on the part of colour-makers. It is obtained by calcination of manganese and barium salts.

*Mitis Green* is a pigment possessing a copper and arsenic base.

*Mountain Green* is a pigment consisting essentially of copper, carbonate soda, produced artificially or obtained as a natural earth.

*Prussian Green* is a name now superseded by Brunswick green.

*Schelle's Green* is a pigment similar to emerald green, being a compound of copper and arsenic.

*Schweinfurth's Green* is a ditto green to the last above mentioned.

*Terra Verte* is a native green, largely consisting of silicate and phosphate of one of the lower oxides of iron.

*Verdigris* is a pigment consisting of a copper base, and, therefore, not of great value as a painter's colour.

*Vienna Green* is another name for emerald green.

*Viridian Green* or *Veronese Green* is a transparent green produced from salts of chromium by elaborate and tedious processes, and therefore very useful in fine-art painting.

*Zinc Green* is another name for cobalt green, being obtained from salt of zinc and cobalt. This green is sometimes called lime green, because it can be mixed with lime as a distemper colour; whereas Brunswick green and stone green, consisting of yellow chromate of lead and Prussian blue, cannot be so used, as the alkalinity of the lime turns the green pigment more or less brown.

*Vermilion* is a pigment that is unlike any other colour in brightness of hue, except red-lead. The latter pigment, however, is a very inferior colour. The two pigments are very different in composition and physical qualities; red-lead being an oxide of lead, and vermilion being a sulphide of mercury; both pigments are very heavy and dense, but red-lead is of a granular structure, whereas vermilion is an amorphous powder. Genuine vermilion is produced by calcining sulphur and mercury together in suitably-shaped crucibles for many hours; the components combine, and form a black sulphide of mercury, which, on further heating, is changed to a red colour, and sublimes on the uppermost parts and cover of the crucibles. When the heating process is complete, the crucibles are removed from the furnace, broken up, all black portions, if any, are separated from the red vermilion, and the latter is then washed and dried for use as a pigment. The black sulphide that remained is dried in a second calcination, so as to convert it into the red variety. Great skill and care is needed to produce successful results, and the product is necessarily costly, because mercury is scarce. Now the unskilful maker of vermilion will leave too much free (*i.e.*, uncombined) sulphur in the product, which will cause many disastrous results when some is mixed with other pigments. All attempts to imitate vermilion have failed, the nearest approach that has been obtained is in the production of vermilionettes. These pigments consist of red-lead, on which is precipitated an aniline dye—eosine—so as to give the scarlet red colour to the pigment. Another near approach to vermilion is obtained by boiling white-lead in a solution of bichromate of potash. The resulting pigment is of a bright scarlet hue and very heavy; but neither of these two imitations equal the genuine article in

qualities. Of the two imitations, the latter is to be preferred, because red-lead that is coloured with eosine will quickly fade when exposed to light. Owing to the cost of genuine vermilion, this pigment is seldom free from adulteration, the usual adulterant being either red-lead or chrome-red, as the second of the above factitious vermilion is usually called, any deficiency of hue being rectified by means of aniline red dyes. Orange mineral or orange chromate of lead is also frequently used as an adulterant; but it makes but a poor substitute, as it is a very crystalline pigment.

*Crimson* and *other Lakes* consist of alum or some other semi-crystalline body tintured with solutions of cochineal (an insect) or of madder (a plant). The colouring matter of the cochineal insect and of the madder plant (the roots are the portion used) yield very richly coloured fluids, which, however, are destitute of sufficient solid matter to be used as pigment; therefore this colouring matter is precipitated in, and intimately mixed with, some inert body such as sulphate of aluminum or barytes (in common lakes, chalk is the base that is coloured with the red colouring matter). These inert bases are destitute of covering power or opacity, and, therefore, all lakes are transparent, consequently their use is limited, being useful only as a glazing colour over some opaque ground. A glaze of crimson lake over vermilion gives a very rich red. The finer quality lakes require great care and nicety of proportion of the ingredients for successful production; but common house-painters' lakes are very easily made. Painters will find it pay them best to use only the genuine lakes for decorative work.

*Indian Red* is an oxide of iron similar to Venetian red, but of a purplish hue. This colour is frequently adulterated with cheap red oxides, and to tone down the brightness of same a little lampblack is added. Of the brown pigments, most of them are found as native earths. Thus umbers are compounds of iron and manganese; siennas are earth compounds of oxides of iron and silica; so likewise are ochres, yellow and red, the tone of colour being dependent on the exact nature of the iron oxides. Some of these earths are so pure that they are ready for use without any preparation; but most of them require washing. This is particularly so with the French yellow ochres. These earths, as they are mined, are put into a series of tanks of water, and stirred up thin, and by a system of gradation the coarser particles are separated from the finer, and thus several brands—usually three—of the ochre are obtained. Some of the earths are calcined, such, for instance, as the umbers and siennas, by which means a change of hue results. Thus we have raw and burnt umber, raw and burnt sienna, and by this calcination the oxide of iron component becomes redder, and so produces this change of hue.

*Vandyke Brown* is a native earth. Many of the ochres are imitated by artificially calcining the raw materials so as to produce yellow and brown of various tones. These colours are generally known as "Mars" colours, such as Mars orange, Mars yellow, &c.

*Prussian Brown* is a soft, unctuous brown pigment of a snuff-brown hue. The brown pigment is not used so much as it merits. It is produced by colouring Prussian blue, but it can be produced in a much more economical manner, thus:—Mix any solution containing iron salts with a solution of barium nitrate or chloride (or even with solid barium sulphate), and then add a solution of yellow prussiate of potash. Collect the precipitate, and calcine it in enamelled iron dishes, when a good brown pigment is obtained. A much superior brown pigment has been obtained by the writer from the waste waters used in washing red oxides of iron by a method somewhat akin to the above.

*Asphaltum Brown* is a native pitch or bitumen, which softens under heat, and, therefore, paint made from such a material never rests safe and sound under the sun's rays. The writer, however, has perfected a substitute for this treacherous brown pigment from mineral ingredients alone. Owing to the cheapness of these earthy colours they are not usually adulterated. Nevertheless, the painter is often served with inferior pigment, as for instance, being supplied with a native earthy colour that has not been freed from extraneous earthy matters or gangue.

Of the black colours, the only pigment in use by painters are lampblack or carbon blacks. There are several mineral blacks, such as black oxide of copper, black oxide of manganese, &c.,

but they are not of a suitable nature to be used in pigments. The only mineral black that is fitted for use as a paint is the black oxide of cobalt, but the price of this oxide, which is over 10s. per pound, puts its use entirely out of the question by painters.

Lampblack formerly, and to some extent at the present time, is the sooty matter collected from burning oils and other fatty bodies rich in carbon. Blacks that are of a kindred nature are the carbon blacks that are so largely produced in America. Of these American blacks, one of the best is that put on the English market by Messrs. Binney and Smith, of New York; the London agency is at 63, Farringdon-street, E.C. Samples of these blacks examined by the writer show a wonderful depth of colour, softness, and good capacity for mixing with oil vehicles. Inferior-made lampblacks contain much tarry matters, which retard the drying of the paint when such blacks are ground up in oil, while badly-made lampblacks are not of a rich, deep, velvety blackness, but inclined to brown.

H. C. S.

### THE ARCHITECTURAL ASSOCIATION.

THE concluding meeting for the present session of the Association was held at 9, Conduit-street, W., on Friday evening, the president, Mr. Hampden W. Pratt, F.R.I.B.A., in the chair. The following architects were elected as members:—E. E. B. Claypole, W. H. Hobday, S. Sanders, and W. H. Ansell. Messrs. G. Vernon, of Harrow, and M. Zimmermann, of Rood-lane, E.C., were re-elected as members, and Mr. Edwin T. Hall, F.R.I.B.A., of Moorgate-street, E.C., was elected, by acclamation, on the proposition of the PRESIDENT. Mr. G. B. Carvill, hon. secretary, proposed a vote of thanks to Mr. Ernest Runtz for allowing members to visit the Crown Theatre, Peckham-road; and also to Mr. J. Dixon Butler for allowing members to visit the new police station at Camberwell, both on May 7th. Mr. Carvill added that on the following afternoon (Saturday last) a visit had been arranged to be made to the Grove Fever Hospital, Tooting, but two or three minutes ago a representative of the architect, Mr. A. Hesse Tiltman (who had promised to conduct the party over the buildings) had brought a telegram from Messrs. Kirk and Randall, the contractors, refusing to allow any members of the association to visit the works. Messrs. Kirk and Randall gave no reason for the prohibition, but threatened to bar the doors against any visitors who might come. Under these circumstances, the inspection of the building must be postponed.

### THE A.A. TRAVELLING STUDENTSHIP.

THE PRESIDENT announced that for the Association Travelling Studentship three sets of drawings had been sent in, and had been hung on screens in the room. The Prizes Sub-Committee had recommended that the studentship be awarded to H. F. Waring, 10, Priory-road, Bedford Park, Chiswick, and that recommendation had been adopted by the Committee.

### FOUNDATIONS FOR LONDON AND RIVERSIDE BUILDINGS.

An exhaustive paper on this subject was read by Mr. ARTHUR T. WALMSLEY, M.Inst.C.E., and will be found *in extenso* on p. 739. The lecture was illustrated by numerous plans and diagrams.

Mr. MATT GARBUTT, in proposing a vote of thanks to Mr. Walmisley, remarked that this was one of the fullest papers ever read in that room. The subject of foundations was of special interest just now, for attention was being called to the mechanical and constructive side of an architect's work by a recent disastrous failure, and he feared more accidents of the same class might be expected in the near future. Architects desired, however, not so much particulars of foundations for extensive warehouses, but figures to guide them in constructing small houses of moderate rental on the London clay. He believed they ought not to go beyond a load of two tons per square foot on such a soil; in factory chimneys, exerting a pressure not exceeding 2½ tons per square foot, settlements had occurred. In London they had a code of regulations as to the thicknesses and height of chimneys, and if these were complied with a safe job would result. It was a mistake to carry the inside lining of a tall chimney up to the capital; in one case within his knowledge where this was done the expansion of the lining

under the fierce heat generated below cracked the outer shell, and these fissures spread during gales; the upper part of the lining was cut out and the cracks did not extend.

Mr. J. H. SHAW seconded the vote of thanks, and asked if water could be effectually kept out of foundations by the use of a raft of concrete, without the addition of a layer of asphalt—*an item which added considerably to the expense.* If so, what thickness of concrete was necessary to prevent the water from rising? For piling he found English larch cheaper, and, he thought, more durable than pitch-pine. The plan of floating buildings on a concrete raft was very well if the walls were well balanced; but, if one side was very much heavier than the opposite one, there was an obvious risk that the building would settle on that side. To prevent this danger of tilting, concrete piers or legs should be sunk to a good foundation beneath the concrete table.

Mr. BERESFORD PITE asked Mr. Walmisley what was the most economical foundation for a two-story on a weak soil in the country. In one case where he was excavating a sub-basement, he had first to underpin and line the neighbour's party-wall. He employed a good builder, who made a satisfactory job of it with slate and cement; but other builders had said that such a job could not be made good. Should the abutting walls of towers be provided with a groove to prevent unequal settlement? If a concrete table was provided under the entire foundation, he could not see why the builder need excavate for legs, for he might simply put in a solid bed of concrete, say from 3ft. to 6ft. thickness, at the required depth. The imperviousness of concrete largely depended on its quality.

Mr. H. H. STATHAM pointed out that there was a risk that a concrete raft might tilt bodily, as Mr. Shaw had suggested, and, therefore, in doubtful soils piers should be carried down in places. The difficulties and great expense of the foundations for the Church of the Sacred Heart on the hill of Montmartre at Paris suggested the necessity for testing the nature of the subsoil before work was commenced.

Mr. E. GREENOP remarked that he adopted in building a house on made soil and refuse the method of rolling the ground, and then laying a layer of 18in. of hard core, on which a raft of concrete was set, and this proved satisfactory. Peat was a very treacherous foundation, from its greasy character. While carrying out work at Smithfield he came across one of the original plague pits, including some skeletons, but he buried it beneath a thick layer of concrete. Where money was a consideration, he enveloped in the concrete cross layers of worn-out tramway rails, which could be purchased very reasonably, and distributed the weight well.

Mr. EDMUND OLANDER, M.Inst.C.E., of the Great Western Railway engineer's office, said, about 33 years ago he had some puzzling collapses in a viaduct on the Metropolitan extension of the London, Chatham, and Dover Railway. The contractors, Messrs. Peto and Betts rebuilt the viaduct as quickly as possible, and then found that the failures were due to the fact that the blue clay on which the piers rested had a water seal nearly parallel with the rails, and that under the weight the bed had shifted. Unless means were taken to get reliable borings before inviting tenders for bridges over rivers the estimates would be greatly increased. Instead of providing holding-down holes in columns built on concrete, it was often possible to secure the columns from being moved by providing broad flanges at the bases, and filling in the concrete round the feet.

Mr. ARTHUR S. FLOWER remarked that when carrying out work in Tottenham-court-road, the contractor sent to him in great alarm stating that his men had come upon a plague pit. He secured some of the bones and sent them to the Natural History Museum, South Kensington, where they were at once pronounced to be those of oxen. The site, it proved, had previously been that of a large slaughterhouse. In another case, it was alleged that a large spring had been tapped during excavation, but investigation showed the influx of water to be only the leakage of a broken supply pipe next door.

THE PRESIDENT, in putting the vote of thanks, said he would have liked Mr. Walmisley to have dealt more fully with the shrinkage of clay under London suburban houses, and to have told them how to deal economically with it. The modern treatment of riverside sites by laying iron grid

iron foundations was a great advance on the old pile system, and had to a great extent replaced it.

Mr. WALMSLEY, in replying, observed that a great deal of the success of concrete foundations depended on the quality of material employed. He preferred pitch-pine to larch for piles, as it could be employed in long lengths and square sections. For small buildings slate and cement might be sufficient for a damp-proof course; but for large works asphalt was essential. In building high towers it was advisable to provide a straight joint at intervals, so that in case of a settlement on one side the cracks would not extend. The construction of legs under concrete rafts were intended to prevent bodily movement in the table under the points where the principal weights came.

### ELECTION OF OFFICERS AND COMMITTEE.

The President read the report by the scrutineers on the voting for the election of officers and committee for the session 1898-99, as follows:—President, G. H. Fellowes-Pryne; Vice-presidents: P. J. Marvin and A. S. Flower; Committee: T. W. Aldwinckle, jun., R. S. Balfour, H. B. Creswell, B. Flight Fletcher, Matt. Garbutt\*, A. H. Hart†, Beresford Pite, W. A. Pite\*, H. A. Satchell\*, and W. Howard Seth-Smith; Hon. Treasurer: Hampden W. Pratt; Hon. Librarian: C. M. Freeman; Hon. Secretaries: E. Howley Sim and G. C. Carvill. Other officers—Hon. Solicitor: W. H. Jamieson; Hon. Assistant Librarian: E. W. M. Wonnacott; Hon. Auditors: H. P. G. Maule and J. W. Stonhold; Assistant Secretary and Registrar: D. G. Driver. (An asterisk [\*] indicates new members of committee; a dagger [†], vice-presidents of last session.) The report, which was signed by Messrs. E. Greenop, W. W. Biss, A. Smithers, G. H. Jenkins, and C. H. Brodie, stated that 292 voting-papers were returned, of which seven were rejected for various reasons, leaving 285 valid ones.

### VOTES OF THANKS.

Mr. BERESFORD PITE, ex-president, proposed a vote of thanks to the out-going president. Mr. Pratt, he said, had proved an excellent and hard-working president, had visited all the classes, and given much time to the sub-committees, and had raised the association to a more flourishing condition than it ever previously occupied. The motion was seconded by Mr. G. H. Fellowes-Pryne, president elect, was carried by acclamation, and was briefly acknowledged from the chair.

The retiring members of committee having been thanked on the motion of Messrs. SIM and CARVILL, Mr. F. G. F. HOOPER proposed a vote of thanks to the President for his services as treasurer, remarking that the President had held this office during several stormy years in the history of the Association, and he was glad to think Mr. Pratt was willing to continue his services. Mr. SIM seconded the motion.

On the proposition of Messrs. B. F. FLETCHER and GARBUTT, Messrs. Freeman and Wonnacott received thanks for their services as hon. librarians, mention being made of the assistance given with the lantern by Mr. Wonnacott. A hearty vote of thanks was also accorded to Messrs. Sims and Carvill for their labours as hon. secretaries on the motion of the PRESIDENT, seconded by Mr. BRODIE; and the closing of a long series of acknowledgments of services were those to the Royal Institute of British Architects for the use of the meeting-room at 9, Conduit-street, and to the School of Design, the Visitors, and Technical Education Board for the facilities granted to A.A. students in connection with workshop demonstrations in lead-working, masonry, and stained glass.

### AMERICAN AND ENGLISH STEEL CONSTRUCTION.

THE remarks on "American and English Practice in Architectural Steel Construction" in the current number of *The Engineering Magazine*, by Mr. Charles V. Childs, are of some interest. The author compares the London and New York practices in iron and steel construction. We may, no doubt, learn something from our American friends, if we desired to reach the standard they have attained; but, as Mr. Childs says, it is very doubtful if the London County Council will ever permit the "steel-constructed skyscraper" to be erected within its area. He

SCREEN OF HAMMERED IRON,  
WITH SHIELD & CREST—OF THE FAMILY OF—  
LEVERSEDGE, LORDS—OF THE MANOR—OF—FROME.  
FORMERLY—IN THE—CHURCH—OF—ST. JOHN. FROME.  
ENGLISH. EARLY 17<sup>TH</sup> CENTY.

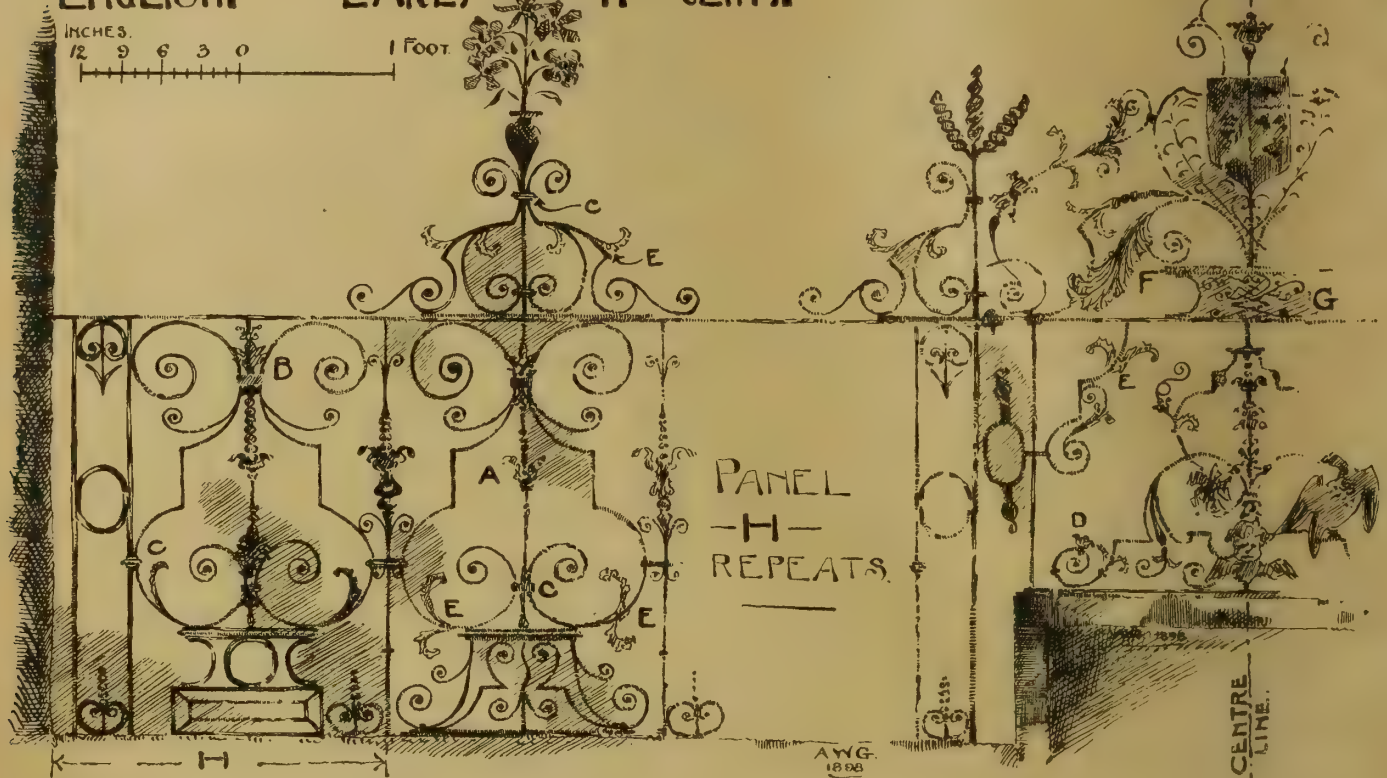

is quite right. He says truly enough: "It is appalling to think what the streets of London, already in so congested a condition, would be like, were it permissible to erect buildings fifteen or twenty stories high. That we are rather behind the New York practice of steel construction will not be disputed; but the question is whether the English system does not conform itself more to the judgment and taste of architects. The author refers to the number of front walls of London shops that are carried on bressumers resting on exposed cast-iron columns—whereas the New York building laws provide "that all cast-iron columns supporting outside walls shall be incased in an outer cast-iron shell with an intervening air-space." We here quote Mr. Child: "The excessive height of American buildings has necessitated the use of the steel skeleton construction, in order to economise the weight, and consequently the thickness, of the walls in the lower stories, which otherwise would occupy valuable space, to say nothing of the cost of material and labour. The usual thickness of walls which, from the nature of the construction, serve only as a covering, is from 13½ in. to 18 in. In England, the thickness of wall at the ground-floor level rarely has to exceed 2ft. 3 in.; if, however, instead of being five or six stories, the buildings were to be three or four times that height, the increase in thickness would have to be enormous, and the steel skeleton framework would probably come into general use." Mr. Childs points out that, whereas in America each story is entirely supported by girders at the floor level of that story, and the weight directly transmitted to the foundations by means of steel columns (or stanchions), the English practice is to place all necessary bressumers at the level of the first floor: these, therefore, having to carry the whole weight of the building above, are necessarily heavy compound girders. The English practice is undoubtedly inferior in this respect, as he shows by comparing the two methods by photo-blocks of buildings, as the framework of the Hotel Russell, London, with its 15-ton girders, and the American steel frame of the Carnegie Building, Pittsburg, for each of which the author designed the steelwork. We

cannot here enter into the subject or compare the details of the two systems which are presented by Mr. Childs; but refer our readers to his paper itself. One of the difficulties of introducing the system adopted in America is said to be that the architect's plans are generally completed before the engineer's work begins. These and other differences of practice are worth attention by the profession, who might adopt with advantage certain principles. To our minds, the English system has its advantages as well as defects. We do not lose the solidity and structural character of brick or masonry building which the New York system does; on the other hand, there is a great deal to say for a system of steel construction which supports each floor independently, instead of resting all the upper stories upon a heavy framework of girders, which have to be enormously heavy and cumbersome.

IRONWORK AT SOUTH KENSINGTON  
MUSEUM.—III.

By G. A. T. MIDDLETON.

IV.—ENGLISH: THE LEVERSEDGE SCREEN.

THE screen from the church of St. John, Frome, bearing the shield and crest of the family of Leversedge, Lords of the Manor of Frome, dates from the early part of the 17th century, and is a specimen of the light and fanciful Renaissance ironwork frequently employed up to the end of last century. Both bar and rod iron are used in it, but the rod only sparingly, and mainly in the form of wrought balls. The exceedingly graceful and flowing character of the leaf at F, and the monogram at G, are particularly noticeable, as is also the somewhat eccentrically-riveted rosette at D; while many objects of the direct copyism of natural forms in iron, as instanced in the flower-pot finials.

Herr Land, Professor of Architecture at Berlin, is on his way to Palestine, to superintend harbour and road renovations necessary for the journey of the Emperor and Empress to Jerusalem.

CONCRETE SLABS.

MR. GEORGE HILL'S paper on "Steel Concrete Construction," read before the American Society of Civil Engineers, treats of a series of important tests on slabs of concrete and steel, in which the steel acts entirely in tension in the bottom section. Sixty different samples were tested, using different mixtures of concrete and of varying spans and thicknesses, and those who contemplate using flat slabs of concrete and steel will do well to consult Mr. Hill's table of thicknesses for slabs for live loads from 75lb. to 250lb. per square foot. For a span of 10ft., it appears, a thickness of 5in. is required for a live load of 75lb. per square foot. Hitherto architects and others have been in doubt as to the actual weight that can be borne on concrete slabs. Of course, Mr. Hill's tables are based on the strict observance of conditions as to components and method of mixing and quality of cement, and those who use the results obtained will have to observe that the conditions are the same in each case. A great many useless and unreliable "data" are published on the strength of concrete due to tests not carefully conducted.

THE COLLAPSE OF ABBEY MANSIONS,  
WESTMINSTER.

AT the Westminster Coroner's Court on Thursday in last week, Mr. Troutbeck, assisted by Mr. John Slater, F.R.I.B.A., as assessor, resumed the inquiry into the circumstances attending the death of the seven men killed in the collapse of the roof of Abbey Mansions, Orchard-street, Westminster, on April 21. Mr. E. Dru Drury, the district surveyor, resumed his evidence. Correcting a statement made on the previous day, he said that the weight of the base of the pier was 66 tons, and not 88 tons. The Coroner said he regarded the building as still in course of construction, and the question as to whether it was exempted from the terms of the Building Act according to section 202 was open for legal decision. It did not seem to him, however, that the action of the district surveyor was closed. The witness said

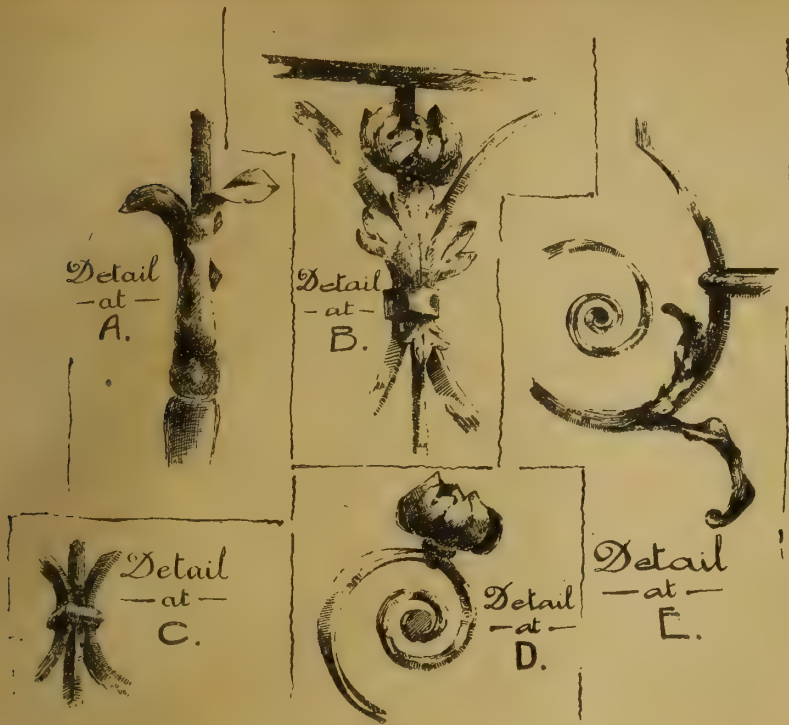

that, to save any question of the kind arising, and to be on the safe side, he was now going on with his supervision of the building. In reply to Mr. Avory (who appeared for Mr. Pawley, the architect), the witness said the safe weight-bearing limit of the pier was 45 tons, and he estimated that six times that weight, or 270 tons, would crush the pier at its base. No large quantity of soft bricks could have been used without his knowledge. Mr. Avory remarked that the witness Collins had sworn that thousands of soft bricks were used. The coroner said he should tell the jury to disregard Collins's evidence altogether. The witness, continuing, said that centring ought not to be

it to set before the centring was struck. He had previously formed the opinion that the accident was due to the premature striking of the centring on information which he now knew to be incorrect. He thought that the bearing of the carriage girder of the sixth floor was so bad that a comparatively small weight would knock it off. The pier was built in Portland cement. By Mr. Fraser: As district surveyor, he had nothing to do with girders or piers. The plans submitted to him did not show the arrangement of the girders at all. Mr. Ashmead, on behalf of Her Majesty's Office of Works, said he was instructed to deny that any alteration in the height of the building

those produced were prepared by witness. The pier, which was to be 2ft. 3in. by 1ft. 6in., was to run up from the first-floor level to the seventh floor—about 78ft. Provision was made in the basement for a stanchion. Detailed plans were prepared by Andrews, the builder's foreman. The dimensions of the pier being given as 2ft. 3in. by 1ft. 6in. was the result of a draughtsman's error. It was true that the plan was given to the contractor to work from. Witness designed the roof, and he considered himself responsible for the pier. He entered into an agreement to lease the building to H.M. Commissioners of Works a week after Rickard sold his interest to Mrs. Leeds. From that time witness merely acted as architect. The stanchion, though desirable, was not put in because the machinery occupied the space where the footings were to be. There was no room for it. He gave his assistant strict instructions not to allow the centring to be struck, having in his mind the possibility of an accident. He still thought the collapse was due to the falling of the concrete. He did not know the dimensions of the pier as constructed. He did not remember receiving a single complaint from anybody about the construction of the building or the materials. By Mr. Gardiner: He acted on the advice of his solicitor when he decided to have a trustee. He was bankrupt eight years ago, and it was possible that his liabilities exceeded £100,000. It was not a fact that Rickard represented him. The increase in the height of the building was not the outcome of a suggestion from the Commissioners of Works: it was raised to make it uniform with the north block. He was under the impression that his action had the approval of the Commissioners. By the Coroner: He had no cause of complaint against Rickard, the builder. By Mr. Kent: He never complained to Thorp, the contractor for the brickwork, about the pier. The witness, asked what training he had had, said he was taught in the Architectural School at South Kensington, after which he was for seven years in the office of his father, a surveyor. He had built many buildings similar to this.

On Monday, Mr. Pawley was recalled and examined by Mr. Horace Avory, his counsel. He said he had been practising his profession about 15 years. Before this occurrence, he had never had fault found with his work as an architect, and there had never been a fatal accident on any of his buildings. During the past ten years he had carried out over £400,000 worth of work. He had previously erected or supervised the erection of lofty buildings of this character. He had prepared calculations showing, in his judgment, the weight that was upon the pier. He made the total weight on the base of the pier at the time of the accident 52 tons 8cwt. 29lb. The weight of the brickwork of the pier above the second floor level, where it left the wall, was 24tons 10cwt. 66lb. Below the second floor level the weight was 14tons 9cwt. 46lb. The weight of the ironwork of the floors and roof upon the pier was 4tons 6cwt. 13lb., including the carriage girders, binders, and lacing joists. The weight of each of the four concreted floors that were in at the time of the accident, calculated at 25lb. per foot super., was 1ton 10cwt. 40lb., making a total weight for the four floors of 6tons 1cwt. 48lb. The concrete on the roof weighed 3tons 8lb. In each case he was speaking of the proportion of the weight that was on the pier. In his judgment the pier was capable of bearing that weight safely. He first heard that a crack had been seen in the pier when Lillywhite gave his evidence last Thursday. He gave directions that the centring was not to be struck. By the Coroner: He could not remember who gave him the details of the pier. The dimensions of the pier which were given on the plan produced were incorrect, but he could not say how the mistake occurred. He made the plan after the accident from particulars supplied by his staff. He could not say who gave him the particulars of the bearing of the ironwork on the pier. The Coroner: There, again, is a most material difference in the way in which the bearing is shown, and the evidence that has been given by various witnesses. Mr. Avory: In your judgment, could the omission of the stanchion have had anything to do with this accident? Witness: No, nothing whatever. Replying to the Coroner, witness said according to the original plans the partitions were to be of wood and glass, but at the request of the Government brick partitions were subsequently put in. Mr. Ashmead, replying to the Coroner, said he

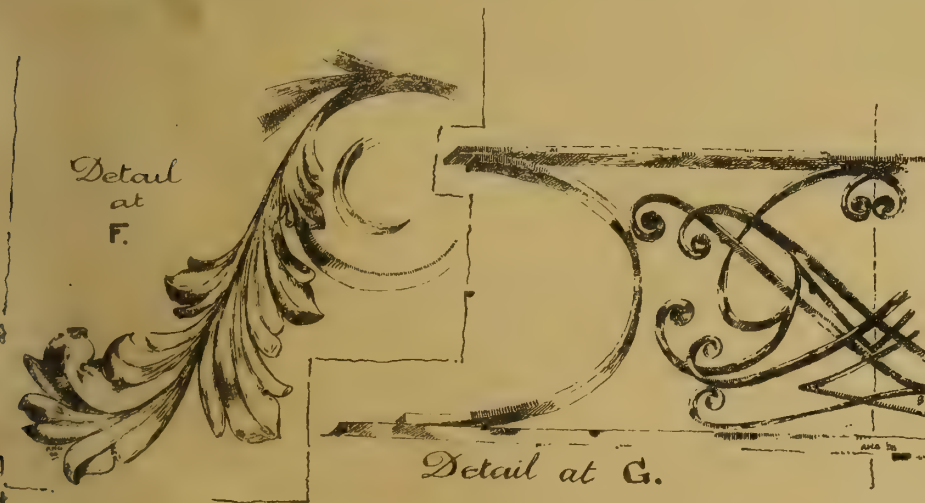

struck until the concrete was dry, but if the concrete was made wet by rain it would be comparatively unimportant. He could not tell from his examination of the fallen pieces of concrete whether the moisture which existed was produced by rain. He did not think that everything that happened would be accounted for by a large lump of concrete falling from the roof and striking one of the girders. His reason for that was that the whole of the pier as well as the 18in. wall was demolished. In his opinion it was the pier that gave way. Either the pier gave way and took down the girder, or the girder fell and knocked down the pier. By Mr. Gardner: If the concrete was not properly mixed, he should have expected to see it fall in small pieces, not, as in this case, in large lumps. The witness, replying to Mr. Kent, said that, taking into consideration the thickness of the concrete, seven days would be the minimum safe time for

was desired by the commissioners. James Lillywhite, recalled, said on the day preceding the accident he was in the basement of the building, and his mate drew his attention to three cracks in the brickwork of the pier about 4ft. or 5ft. from the ground. The cracks were 7in. or 8in. long. The largest would admit part of a trowel. By Mr. Marshall: He mentioned the matter of the cracks to a member of the jury whom he met outside the Court two days ago. Mr. Marshall said that was most irregular. The Coroner agreed. Mr. C. J. C. Pawley, the architect, recalled, said he believed he was the owner of the freehold as *cestui que trust*, and Mrs. Leeds was his trustee. He might have recommended the building to Mr. Rickard. Witness had nothing to do with arranging the subcontracts; but he directed Banks's fireproof work, and his assistant, Simpson, directed Murrell's work. After a time the plans for the south block were altered, and

had communicated with the Commissioners of Works, and they instructed him to say that they did not at present propose to call evidence. The Coroner said that in those circumstances they would have no opportunity of tendering evidence, as the inquiry could not be adjourned indefinitely. Mr. Thorp, the contractor for the brickwork, recalled, said the seventh floor girder rested on a 4½ in. template in the chimney stack. He could not say who ordered the fixing of the template in that manner. He called the attention of Andrews, the general foreman, to it. Witness said the detailed plans were produced that day for the first time. Andrews, the general foreman, was also recalled, and produced a number of plans which he had found since he last gave evidence. Mr. Avory put in a letter written by Rickard, the principal contractor, to Mr. Pawley in October, 1896, which, he said, completely met the suggestion that from the outset Mr. Rickard was only the nominee of Mr. Pawley. In this letter Rickard said he desired to elucidate the fact as to whether Mr. Pawley "put him down as an ass," and pointed out that there were eight offices to be let at £30 a year, making it a total of £240. The cost of erection would reduce it by one-half, or £120. The building would realise £1,920 yearly, and, said Mr. Rickard, "I will not sign any agreement for a less sum, for it would pay me better to keep it." Mr. H. Collins, F.R.I.B.A., district surveyor for the Eastern division of the City of London, said he had had experience of Mr. Pawley's work, and had never had reason to find fault with it. He had heard the evidence in this case, and had visited Abbey Mansions. The conclusion at which he had arrived was that the cause of the accident was the unfortunate removal of the centring before the concrete had properly solidified. He had examined some of the fallen concrete, and considered it well mixed, and a proper material for its purpose. Concrete 9 in. thick should, in his opinion, be allowed to remain from 15 to 20 days before the centring was struck. In his opinion, the fall of the concrete was sufficient to account for all the subsequent phases of the disaster.

Resuming his evidence on Tuesday, Mr. H. H. Collins said he thought it very feasible that the concrete caved in between the lacing joists as had been described by one of the previous witnesses. The concrete would then fall in large or small pieces, having no centring underneath it, and if it fell through a depth of 22 ft. it would probably crash on the ironwork underneath, causing it to act as a lever on the pier and throwing it over. He thought that the ironwork of the roof would have stood in its skeleton form had the pier remained in its position. It was the falling of the pier that caused the iron girder of the roof to go. Had the pier been larger, it would not have withstood the falling concrete. The probable spot at which the pier would give way, if it collapsed from its own inherent weakness, was at its base on the first floor. What had been termed "a pier" was in reality a series of piers. The total weight of the brickwork of the series of piers was 27 tons 19 cwt. The total weight on the pier at its base at the time of the accident was 45 tons. It would require a force of eight times 61 tons to crush the pier. Brickwork in cement required from 60 to 70 tons per foot super. to crush it. His authorities for that statement were Professor Rankin and Professor Cawthorne Unwin. One could put up very large buildings such as they had in America if bolts were used on each floor, and provided there was a base sufficiently large. The addition of a stanchion would have decreased the burden that the pier had to bear, and it would have been wise to have put up a stanchion. In reply to Mr. Gardiner, the witness said he agreed with Hurst's rule that an isolated pier or monument ought not to be built higher than twelve times its largest size at the base. But what had been described as a pier in this case was not a pier, and an architect was supposed to have a little common sense and to know how to use it. By Mr. Ellis Griffith, M.P. (counsel for the roof contractor): The only fault he found with the building was that the centring was removed too soon. He did not believe the evidence of the witnesses who said that the concrete struck the pier, although they might have imagined that that happened. Mr. William Eve, F.S.I., of Union-court, Old Broad-street, said he had had considerable experience in the construction of buildings. He had examined Abbey Mansions, and was of opinion that the load on the brick pier weighed 53½ tons. That he

considered to be a safe weight. The fact that the pier was found in large pieces showed that it was of good construction. He would not like to strike the centring of a concrete roof until after the expiration of 15 days, and he would prefer to allow a lapse of 20 days for the concrete to solidify. He thought that the premature striking of the centring was the cause of the accident, and the fact that the building fell while the centring was being struck confirmed him in that view. His idea was that the concrete fell on the carriage girder of the seventh floor, a distance of 11 ft., pressing the girder down and prising up the pier. The pier, no doubt, dragged down the girder joists and the brickwork. By Mr. Avory: There was lateral pressure in concrete. If the "green" or unset concrete fell, the consolidated concrete would follow as soon as the pier was disturbed. In reply to Mr. Thomson, witness expressed the opinion that there ought to have been a stanchion. By Mr. Ellis Griffith: He did not agree with everything that Mr. Collins had said. He had known many buildings to be constructed without plans, but he had not so constructed them himself. It was improper, in his opinion, to fix a girder in a flue without a stanchion being put in. Some of the concrete must have fallen before the pier lurched. Without the stanchion the pier would not have been sufficient to support the building when it was occupied. Mr. E. A. Gruning, vice-president of the Royal Institute of British Architects, said centring should not be struck until about three weeks after the concrete was laid. He had heard the dates upon which the roof was concreted and the centring struck, and did not think the concrete could have hardened sufficiently to render the striking safe. In his opinion it was the falling of the concrete on the girder that caused the pier to collapse. It would have required a very much larger pier to have resisted the falling of the concrete roof. By Mr. Avory: He thought it extremely unlikely that the first thing that happened was the buckling of the pier. Frederick Rough, a labourer employed on the building at the time of the accident, said he called the attention of Andrews, the general foreman, to some cracks in the pier. Andrews attributed them to the engine. Two of the bricks of the pier were crushed, and there were cracks all round it at distance of 4 ft. from the ground. Andrews told him that the bricklayer would strengthen the pier. By Mr. Avory: He was certain there was a pier and not a wall in the basement, and that there was an archway over the pier. Mr. Avory remarked that as far as he knew none of the plans showed a pier in the basement. James Andrew, the general foreman, recalled, said the archway was carried on to the chimney-breast, not on to the pier. He absolutely denied that the last witness ever spoke to him about cracks in the pier. He noticed some scratches on the wall; they were caused while the engine and mortar-pan were being removed. By Mr. Thomson: He told some of the men that the engine had knocked a corner off the wall. There were so many sub-contractors that he did not know all the men. He sent a man to examine the pier on each floor, but had never any thought of strengthening the pier. Dixey, the man sent by the last witness to examine the pier, was called, and said he found nothing the matter with it. The archway was carried on to the party-wall in the basement. Walter Ridley, a bricklayer employed in the basement of the building the day before the accident, said the archway was right on the pier as shown on the plan produced. He did not notice any cracks in the pier. The coroner remarked that there had been some extraordinary surprises throughout. He had never heard so many contradictions in important matters of fact.

Edwin Thorp, the contractor for the brickwork, recalled, described an opening which existed in the brick wall in the basement. That hole, he said, was between 3 ft. and 4 ft. away from the pier, and it was incorrect, as was stated on the previous day, that there was an archway leading close on to the pier. George Curtis, bricklayer, gave corroborative evidence. Mr. Thomas Blashill, F.R.I.B.A., F.S.I., superintending architect of metropolitan buildings and architect to the London County Council, was called, and said he attended, by request of the Council, to give expert evidence. He had examined the south block of Abbey Mansions, and had heard the evidence. There could be no doubt that the collapse of the interior of the building was due to the fall of a detached pier,

whether caused by the fall of concrete or not. With regard to the strength of the pier, he did not doubt that it was built of fairly hard stock bricks set in cement mortar. He made its horizontal area 7 ft. at the bottom. On the fifth-floor level its horizontal area was diminished to 5 ft. It was connected on one side to a wall which ran up the basement story and the ground story, subject to any opening which there might have been in it. He made the weight of the pier itself, together with the weight of the floor and the roof and their girders complete (so far executed at the time of the accident) round the level of the basement floor, to be 48·43 tons. This was rather less than other witnesses had made it; but in this calculation no account had been taken of the 4½ in. party-wall which was in course of construction, nor of the storing of building materials. The first question was the resistance of good stock brickwork in cement. That depended largely on the height of the pier in proportion to its smallest horizontal dimensions. Its total height of 105 ft. or thereabouts was entirely out of proportion to its width; but he did not make that great height the basis of calculation. He attached very little importance to the wall with which it was connected on the lower story. The wall was built in mortar while the pier was in cement, and any considerable strain on the pier would break its connection with the wall. A pier of proper construction, stiffened at intervals of about 11 ft., might, with some qualification, be dealt with in separate sections; but in order to justify this the floors must be quite rigid, and the construction of the pier, especially where it was connected with the floors, must be perfect as regarded the strength and the arrangement of its parts. If such a pier should be in any degree out of the upright or badly constructed, or subject to the least pressure, except perpendicularly, it must be very materially weakened, and in this way its great height would render it liable to excessive stress in particular parts. Subject to these observations, he had endeavoured to find out the crushing strain and the safe load of good stock brick and cement. On this point there was great variety in the published experiments. The crushing strength of stock brickwork was given at from 18 tons to 30 tons, and even as high as 70 tons per foot super., and the proportion of safe load to crushing load was given by various authorities at from one-fourth to one-twentieth. He believed it had long been the practice of architects to adopt a load of from 5 to 6 tons per foot super. as a safe load. Professor W. C. Unwin, in speaking of some recent experiments on the strength of brickwork made by a committee of the Royal Institute of British Architects, said that from 4 to 7 tons was a safe load, and that 7 tons was the extreme limit with prudent architects. He thought that recent experiments showed that the safe load would be under the 7 tons per foot given by the witnesses, which was as much as one-half or one-third of the pressure which had crushed a full-sized pier in experiments. On each floor the regular brickwork was interrupted by stone templates going over the whole surface of the pier, and by girders. The girders ran through six courses of brickwork. In no case did the height of any girder coincide with any course of brickwork. No experiments such as had been alluded to in this inquiry had ever been made, so far as he knew, on brickwork of this kind. The strongest arrangement as regarded the big girder would have been to have fixed it within the middle third of the area of the pier. Any departure from that position materially weakened the strength of the pier. This girder was within six inches on each floor of the west end of the pier, and bore principally upon one corner of it. In this way the pier at each floor was seriously weakened in its construction, and, besides, was seriously overlaid. He had no doubt that at the time of the accident the lower half of the pier, at least, was in certain places dangerously overlaid, and that this danger was increasing daily. It might have collapsed at any time from that cause, together with the weakness of construction. Upon the occurrence of any appreciable shock it was nearly certain to collapse. It was not necessary, in his opinion, to assume a fall of the concrete from the roof, and had the disaster not happened at the time when the centring was being removed a fall of concrete would hardly have been suggested as the cause of the accident. As to the concrete roof, he was told by the engineer and chemist to the London County Council that the cement which they had tested was very good. The

material of the furnace clinker or ashes must have varied considerably, as some of the concrete fell in large pieces and some pieces were weak. He believed no coke-breeze was found in the concrete. He had used coke-breeze very largely, and it was not like this. He would not think it unsafe to strike the centring of coke-breeze concrete at the time the centring of the roof of the collapsed building was struck. They struck centring under coke-breeze floors,  $4\frac{1}{2}$  in. in thickness, in a week or ten days, but the centring in this case was struck in less than a week. A flat roof given that time should have carried itself, but if a portion was of very bad quality it might fall. He had very little doubt that, however it might have fallen, it would have caused the collapse of the pier. He thought that if the pier gave way, without the shock of the concrete, at any part of its height, there would be a short period during which it was going downwards through the crushing of the brickwork, and horizontally in the direction of the staircase. Then after a short period the whole building would collapse, as had been described. If the roof concrete gave way he should expect it to break about the middle in the direction of its length, and under conditions which he described, it would break into two pieces, roughly measuring about 10ft. by 2ft. each, or 20ft. super. The Coroner: I should like to know what your views are with regard to the control of the London County Council? I agree with the district surveyor, Mr. Dru-Drury, that in no circumstances could the district surveyor on such a building have, under the existing state of the law, any control over these piers and girders. Do you wish to give any opinion as to whether there ought to be any such control? Personally, and as a public officer, I think there should be such control. I believe that London is quite exceptional among large cities, whether on the Continent or in America, in being without control of that kind. I have examined building plans for mansions in large cities, including Berlin, Budapest, and others, and I have seen them scored over with the blue pencil marks of the officials, increasing the size of the girders and piers. Then in this respect the district surveyor and London County Council have imperfect control over the construction of large buildings? Yes, to that extent. By Mr. Hugo Marshall (for Mr. Pawley): He did not think the upper part of the pier was overloaded. The danger of overloading came somewhere towards the bottom—the second or third floor. He thought that five tons per foot super. was a safe load; but he was quite in the hands of scientific men on the subject. On the first floor the load weighed 5.64 tons. It was there that the danger occurred most. He could not say that all the danger was below the third floor, as there were no ties on the fifth floor. Any kind of shock, such as that caused by a scaffold-pole falling end-on a girder would have been likely to cause the collapse. He could not go so far as to say that the falling of the concrete knocked the pier down; he did not know how much fell. If the concrete fell first, then it no doubt caused the collapse. It was true that such a shock might destroy a properly-constructed building. He did not consider seven tons per foot super. a dangerous load for this pier. Mr. Marshall: Do you agree with the other expert witnesses that even if the pier had been reasonably larger, it would have been crushed by the falling concrete? I have some difficulty in answering. But if that pier had been of sufficient size, and the concrete had been so soft as to fall, I should have considerable hope that the building would stand. By Mr. Thomson: Assuming that the perpendicular, the ties, and the foundation of the pier were perfect, the fall of concrete might bring it down. By Mr. Gardiner: Any appreciable weight falling on the building might have caused it to collapse. By Mr. Kent: Seven tons per foot super. was the extreme limit for a prudent architect to adopt for a safe load. The actual load on the pier was 6.9 tons per foot super. Mr. E. A. Gruning, V.P.R.I.B.A., recalled, said that in his judgment a safe load to put upon the pier, having regard to its construction and all the details, was seven tons per foot super. There was nothing in the construction of the pier to suggest to his mind that it was the cause of the accident. The Coroner: If you had been the architect of this building would you have put in a pier of that description? I think it possible that I should have used iron columns. Mr. S. Murrell, the roof contractor,

recalled, produced his invoices for 41 yards of coke-breeze, which he said was used in the construction of the roof. This closed the evidence.

The Coroner, in summing-up yesterday (Thursday), reviewed the whole of the evidence, and pointed out that the duty of the jury was to find whether there was any culpable negligence on the part of any persons who had contracted or sub-contracted for any work. There were only two suggestions for the jury to consider, to arrive at a just verdict. The first was whether the concrete was not properly set or properly mixed, and whether the removal of the centring was the cause of the accident. The next was whether the pier was improperly constructed and faulty in design. There was also another alternative—that the collapse was due to the falling of the concrete and the pier combined. With regard to the pier, he would ask them to disregard the evidence of Collins, the stonemason. There was no suggestion that the bricklayers had not done their work properly. Mr. Pawley took upon himself the responsibility of the construction of the pier. That being so, they would have to consider if there were any culpable neglect on this head. The question would be one of criminal responsibility. They must consider the fact that the pier had been carried up considerably higher than allowed by the Building Act. It was clear that Mr. Pawley had an interest in this venture from the start, and actually bought the builder up, and, as a matter of fact, Mr. Pawley was the beneficial owner. He warned Mr. Pawley at the commencement of the inquiry that it would have been desirable if he had been advised by the County Council at the early stages. There were many statements in Mr. Pawley's evidence which were not right. The brick pier was not at any time 3ft. 6in. by 2ft. 6in., and it was perfectly plain that the calculation Mr. Pawley had submitted was not made until after the accident. Mr. Pawley found it necessary to correct himself on several occasions, and therefore he did not think the jury need take very much notice of anything Mr. Pawley had said at that time. With regard to the 9in. wall, that was another fiasco. A great portion of Mr. Simpson's evidence had been put on one side by expert evidence. There was actually no clerk of the works, which was a most astounding fact in buildings of these dimensions. There could be no doubt that some of the brickwork had been crushed by the enormous weight upon it. The evidence of Mr. Andrews, the general foreman of the building, was very peculiar. This witness had said things about the building of the pier which were absurd, and some of his evidence had to be dragged out. It showed great carelessness that he should have permitted the improperly mixed concrete to be taken up to the roof. Mr. Troutbeck then commented strongly upon the fact that no mention had been made of the hole left in the main wall for the workmen to pass through, until nearly the close of the inquiry. He said the extraction of evidence from witnesses was like drawing teeth, and he could not understand why, in such a case, there should be any reason for concealment. The evidence of Thorp, the master bricklayer, Mr. Troutbeck thought, was exaggerated, and he hoped Mr. Thorp's statement that he came down from the roof partly because he thought it was dangerous, leaving his workmen up there, was an exaggeration; for to warn the men under such circumstances was a moral obligation. Commenting upon the knocking away of the centring from under the concrete roof, the Coroner said it was extraordinary that Parker should have done this after he had apparently received positive instructions not to. Referring generally to the contradictory evidence, the Coroner pointed out that nearly all the witnesses were employed by people who were to a certain extent interested parties.

#### THE VERDICT.

The jury found that the deceased men met their deaths in the collapse of the Abbey Mansions, which collapse was due to the faulty construction of the pier, owing to the culpable negligence of the architect. They were also of opinion that the concrete was improperly mixed, but that this was not the initial cause of the accident.

The Coroner expressed the opinion that the verdict was equivalent to one of Manslaughter against Mr. Pawley, the architect.

Bail was fixed at £200 for Mr. Pawley, and £100 for his solicitor.

#### FOUNDATIONS AS APPLIED TO LONDON BUILDINGS AND RIVERSIDE FOUNDATIONS.\*

THERE are few subjects with which an architect has to deal which involve the consideration of so many points of detail as the subject of foundations. It involves a knowledge of the applicability and the durability of various materials, experience in drainage, and not infrequently an acquaintance with contractors' plant as well as the best way of economically distributing structural loads, for which expert knowledge engineers are usually given credit. The variation in London soils and subsoils is well described in a pamphlet recently written by Mr. Horace B. Woodward, F.R.S. So much of the top soil with which foundations are concerned is of an artificial character that only actual excavation can determine the true nature of a site. Geological maps furnish standard information respecting the natural lower strata, but possess very little value as regards the mixed character of the top soil. Made ground may be a foot to 25ft. or more in thickness. At the Bank of England there were 22ft. of made ground resting upon 4ft. of gravel. Some of the made ground is of ancient date, and preserves relics of Roman occupation, but in some parts the subsoils have been excavated for ballast or gravel, as at Kensington, or for brick earth, as at Highbury, and the pits filled in with rubbish. A rock which forms an excellent and unchanging foundation in one situation may prove a dangerous foundation in another. Thus, chalk forms a good limestone foundation in certain positions, but when it dips towards a slope or a cliff, with an outcrop of the gault or other underlying clay, it is a very unsuitable foundation for any building, as the landslips of the Isle of Wight and of the Dorsetshire coast bear witness. Chalk also is subject to dissolution by the action of carbonated water, whereby comparatively wide cavities become formed in its surface, which may be wholly or partially filled with gravel and sand, and cause inconvenience. In the same way, to be partly on gravel and partly on clay or brick-earth, to be on or over the margin of an old excavation since filled with rubbish may lead to trouble. Where foundations are carried down into clay, the excavation may form a tank, into which the water from surrounding gravel may accumulate. The

#### VARIATIONS IN THE UPPER SOILS OF THE METROPOLITAN AREA

may be illustrated by the following records:—At Chelsea Barracks, boring through made-ground and running sand shows the clay to vary very considerably in depth below Trinity high-water level, which is 12ft. 6in. above Ordnance datum. In 1895, a return of the burial grounds in the County of London, with a statement of their size, ownership, and condition was prepared for the London County Council by Mrs. Basil Holmes, from which it appears that there are 362 burial-grounds existing in the County and City of London, of which 321 are disused. Of this number 90 are employed as public recreation grounds, and the remainder are closed. Prior to the passing in 1884 of an Act to prevent the erection of buildings on burial-grounds, about 100 to 150 graveyards had been entirely built over, appropriated as sites for railways, or annihilated by new roads. Her Majesty's Stationery Office Waste Department stands on a site in Earl-street, Westminster, formerly used as Hartley's marble works, but originally the site of the plague pits connected with the Tothill-fields pestfield, of which area Vincent-square now remains open as the playground of Westminster. The pest-houses erected in 1642 were not removed until this century. Charterhouse-square, Holborn, is also a part of the site of a burial ground, dating back to the 14th century, for the burial of those who died in the plague at that time. In the County of London the only encroachment now permissible on a disused burial ground is the enlargement of an existing place of worship, although in the City the Commissioners of Sewers have the right, under certain circumstances, to appropriate portions of them for the widening of roads. There are excavations in the Metropolis in which human bones have been discovered on sites which have been dug out, and then filled in with debris from disused burial grounds adjoining, when the latter were used for

\* By ARTHUR T. WALMSLEY, M.Inst.C.E. A paper read before the London Architectural Association on Friday, May 20, 1898. (See report p. 735, a. 12).

buildings before the passing of the disused Burial Grounds Act (47 and 48 Vict.) The above report, which is accompanied by a map, definitely fixing the position of old burial grounds, is therefore of great value. A boring made in Tallis-street, on the Victoria Embankment, showed the following strata:—(1) 1ft. 6in. ballast, dirty; (2) 6in. green sand, wet and dirty; (3) 2ft. peaty clay; (4) 6in. green sand; (5) 5ft. 6in. peaty bog; (6) 9ft. running sand; (7) 4ft. clean ballast resting at a depth of 23ft. below the ground line upon blue clay. At boring at Highbury New Park gave (1) 2ft. made ground; (2) 18ft. loam; (3) 9ft. sand; (4) 4ft. peat; (5) 8ft. gravel and sand. A boring at Peckham gave (1) 3ft. gravel; (2) 14ft. loam and sand; (3) 3ft. gravel. At Kensington, the soil is described by Mr. W. Bennett Rogers, in a paper read before the Institute of Estate and House Agents, "to be mostly a rich dark loam; secondly, a silicious gravel from 5ft. to 10ft. in thickness; and, thirdly, a strong leaden coloured earth known as blue clay." The foregoing observations show that while trial bore-holes should always be made before designing a foundation, to ascertain the character of the subsoil, care must be taken

#### NOT TO CALCULATE UPON UNIFORMITY.

Thus at the Admiralty extension new buildings forming block 2, now in course of erection by Messrs. John Mowlem and Co., one of the bore-holes upon the south-west side of the old buildings showed the clay to be about 29ft. 6in. below the surface of the ground, while actual excavation proved the dip of the clay to be such that in the execution of the new building it became necessary to underpin the north-west corner of the old building at the deepest part, 42ft. below the ground. The strata in the bore-hole referred to gave about 18ft. (average) made ground, 2ft. ballast, 5ft. dirty sand, 2ft. 6in. clean sand, with 2ft. running sand and slurry, making a depth of 29ft. 6in. to the clay. The old walls of the Admiralty premises were found to be built upon oak sills. These were removed where underpinning was necessary, so as to build and pin up with solid brickwork. There being two floors below the ground in the new building, a concrete retaining wall has been constructed completely round the exterior below the ground, and joined up to the underpinning work; the whole site is covered with concrete 6ft. thick, thus forming a huge tank of an average inside clear depth of 20ft., in which the basements are built. The underpinning to the old wall consists of brickwork 4ft. 3in. thick and 14ft. to 20ft. deep, below which concrete 6ft. deep, with set-offs of 12in. on one side is inserted to a width of 5ft. 3in., for the upper portion of 3ft., and a width of 6ft. 3in. for the base or lower portion of 3ft. Messrs. Leeming and Leeming are the architects, who also designed block No. 1 forming the new Admiralty Buildings facing St. James's Park, the foundations for which are likewise somewhat appropriately placed in a dry dock built upon the London clay at a depth of 30ft. in solid concrete 6ft. thick. At the Hotel Victoria in Northumberland-avenue, Mr. Florence, the architect, found that this building has a frontage of 300ft.: 38ft. 6in. made ground clay and gravel mixed, 4ft. gravel and sand, 6ft. rising sand, 2ft. fine ballast, and at a depth of 50ft. blue clay. At the south end the clay was 43ft. down; at the north end 37ft. The front wall was constructed on a concrete bed 9ft. wide. Another bed 15ft. wide carries the two walls of the central corridor. The whole site was surrounded by a similar wall of concrete, about 6ft. wide, forming a species of boxes, and the whole covered with a depth of 6ft. of concrete, upon which the walls were raised. The spaces between are now probably full of water. At the Grosvenor Hotel, Piccadilly, there were 4ft. of made ground overlying 11ft. of alluvium, and 9ft. of sand and gravel. Messrs. J. Grover and Son, Wilton Works, New North-road, N., forward the accompanying description of bore-holes made in Parliament-street before starting the trenches. The bore-holes were taken at the corners of the site. The foundations are Portland cement concrete, and go down to the ballast or to the London clay. The concrete was 6ft. and 5ft. wide under external walls, and 4ft. under the interior walls. This site is that of an old creek that ran up to Scotland Yard. When Messrs. Grover were building New Scotland Yard they came across old wharves and barges at about 30ft. below the level of the Embankment. As the water from the land still finds its way through the old

channel, the foundation required the aid of pumps. Messrs. Holloway Brothers, of Battersea, formed a foundation where they encountered running sand upon a site in Parliament-street (the Swan Electric Light premises, near Grindlay's bank) by driving small piles—7ft. or 8ft. long and 6in. circular, and pointed—as close together as possible over the whole foundation; then sawing off the tops level, and building a concrete raft 7ft. or 8ft. thick over the whole area. The new City Hall, Belfast, designed by Messrs. E. Thomas and Son, architects, Queen Anne's-gate, stands on a piled foundation, the site being a deep stratum of yielding alluvial deposit. Such foundations are common in Belfast, and generally consist of larch or other straight round timber, often 40ft. to 50ft. in length. The custom is to saw off the heads of the piles after driving to a proper and uniform level, and place upon them timber sleepers to aid the support of a concrete table. Mr. Florence obtained the following section for a building in Victoria-street, Westminster:—(1) 4ft. made ground; (2) 4ft. black peaty silt; (3) 3ft. sand and gravel; (4) 13ft. coarse gravel. At the Army and Navy Auxiliary stores the formation at about the same depth was also found to be sand and gravel. A clear stream of water runs through it, in which a chimney shaft was built by the aid of pulsometers and sumps. The area of these premises has a foundation of 5ft. Portland cement concrete all over it, 7lb. lead being used as a damp course. At the National British Gallery, Grosvenor-road, designed by Mr. Sidney R. J. Smith, the soil consists of surface earth over peat, under which are clayey bands and bands of sandy clay, all of which were pierced by the foundations until the ballast of the river bed was reached at an average depth of 17ft. to 20ft., and in some parts 25ft. No particular difficulty was experienced. The site is that of the old Millbank Prison, known as the Penitentiary. At the gas-works in the Horseferry-road 30ft. of gravel are recorded as having been passed through, and this gravel is frequently waterlogged, so that where foundations of houses pass into it with unprotected basements, the water becomes troublesome during high tides, rising in the cellars of houses built upon such low-lying ground. Alluvial deposits prevail over part of the area, consisting of silt and clay varying in thickness from 7ft. or 8ft. to a thin crust. The gravel and sand on the site are of considerable thickness. In the case of a clayey subsoil overlying a watery gravel, where structural loads are not sufficient to warrant extending the foundations through the gravel to the clay, it is well to leave a thin crust of the clayey material over the gravel so as to prevent the water working up through the foundation, which would cause the gravel to work loose. In dealing with a loamy soil it is quite possible to overload a foundation. Water will drain through a loamy soil that is not spongy. When dry, like cheese, it does not then contain the argillaceous matter which gives it a spongy character, and which would cause it to run, under pressure, like mud. Brick seating on concrete has been employed for piers to a warehouse, built over a good dry compact loam foundation.

#### CONCRETE FOOTINGS

provide a distribution of weight over the whole area when a sufficient depth of concrete for a footing is put in, because every cavity or unevenness of the ground is properly filled with plastic material. Concrete also is quite as good as brickwork or masonry to bring the work up to the surface under ordinary circumstances, but in the case of piers subject to vibration, brickwork is decidedly preferable. Brickwork also may be used of smaller dimensions than concrete, so that the space occupied is less. Thus, at the Borough Market, Southwark, where the foundations had to be carried down from 22ft. to 24ft. below the ground line, the piers carrying roof columns were built in brickwork over concrete footings. When stone templates are introduced on top of piers, as is frequently found expedient, it must be remembered that the great thing is perfect bedding of them in cement. At the Tower Bridge, layers of canvas and red lead were placed between the base of the steel column and the granite beds upon which they stand, in order to obtain a uniform bearing over the whole surface. Felt carefully laid under the bearing of iron girders is preferable to sheet lead, unless the pressure is sufficient to crush the lead, so as to insure a uniform distribution of pressure. Portland cement should be used for concrete work under a bed of stone. Ordinary lime concrete is long in setting. The

centre of the mass of a large concrete block may not become hard for years, where a block made of one part Portland cement to seven parts of other approved ingredients, carefully and well mixed, will safely bear a load of five tons per square foot. According to Mr. Stoney, bricks not of an extra hard description in cement will bear a crushing weight of 521lb. per square inch, or 33½ tons per square foot. Allowing a factor of safety of 6, we obtain 5·6 tons per square foot safe load. Rivington's notes on building construction give brickwork in mortar ½cwt. per square inch safe resistance to compression, or 3·6 tons per square foot. The resistance of brickwork to cracking or crushing in a pier is much less than that of the bricks alone. Ordinary stock bricks will stand 8cwt. per square inch, or 5½ tons per square foot. Much valuable information hereon was given in the investigations made by three series of experiments on brickwork tests, made for the Royal Institute of British Architects, and published in their *Journal*. In the case of the Imperial Institute bearing plates for the girders, where resting on brickwork, were calculated for 16 tons per square foot of area, but then special bricks of Jennings manufacture, built in cement, were employed. In fixing stanchions over a cement base it is necessary to provide ample space for grout. The stanchion is set vertical by means of long and shallow wedges, occupying a depth sufficient to allow 1½in. under the base of the stanchion, and a hole 2in. diameter should be left in its base, as near the centre as possible, not to pour in the grout, but to see it rise when the under part of the stanchion is completely grouted up. A temporary trough is formed round the base to receive the liquid grout, and the wedges should not be drawn until the grout has well set. In the case of a roof of three spans, subject to the effects of lateral wind pressure, when supported on side walls with intermediate columns, where the situation did not permit either the addition of buttresses or of anchorage in these side walls, the horizontal reaction of the wind-pressure may be taken by anchoring the intermediate columns to a concrete foundation. At the Institution of Chartered Accountants, Moorgate-street, Mr. John Belcher found the ground so unreliable that he adopted the precaution of putting a layer of Portland cement concrete over the whole site 3ft. deep. The result has been satisfactory, no settlements having occurred anywhere. At Kennet's Wharf, upon the Middlesex side of the river near Southwark Bridge, the foundation consisted of 8ft. of concrete spread all over the site and increased in thickness under the main walls. The late Mr. G. E. Street, R.A., used selenitic lime in the concrete foundations of the Law Courts. Under some of the walls it was 7ft. thick, and that under the walls of the Great Hall was 10ft. thick. Portland cement concrete rafts, 2ft. thick, have been built under five-story buildings on compact loamy soil over gravel, the concrete being dipped where required to obtain the proper fall for drainage-pipes to run over the surface. Another plan frequently advantageous to adopt is to sink piers 12ft. to 15ft. (centres) apart, and 4ft. 6in. square, in pot-holes dug out of made ground, and then to form concrete arches over the intervening unreliable ground, with a minimum thickness of 18in. This plan was adopted by Messrs. F. and H. F. Higgs for some premises at Stratford and at L33 Bridge, also for a church at South Bermondsey. In the latter case, 6ft. of soft clay or mud, then 5ft. or 6ft. of peat and 4ft. of running silt had all to be gone through before the gravel was reached, and the concrete piers were here connected by a concrete lintel 3ft. thick, in which steel joists were embedded. At the Institution of Civil Engineers, 25, Great George-street, Westminster, the foundations to the two party-walls upon each side of the Institution building were carried down about 22ft. below the pavement level, that on the west side being 22ft. deep, that on the east side 24ft. The front wall was 25ft. below the paving level. The concrete was laid under walls only, and was about 10ft. 6in. by 5ft. 2in. wide at the east party-wall. Mr. Charles Barry was the architect, and Messrs. John Mowlem and Co. were the contractors. The Institution of Mechanical Engineers at Storey's Gate, Westminster, stands on what appeared to be a wharf, and the roadway in Princes-street was possibly an inlet of the Thames. The contractors excavated the piling and black earth—formerly, doubtless, faggots—and gradually came to a fine Thames sand at a depth of 23ft. below the roadway, gradually



getting coarser until fine gravel was reached at a depth of 28ft. below the roadway, upon which the concrete foundations were laid. The main walls were then marked out and excavated to a mean level of 28ft., the strata gradually developing into a fine gravel, which Mr. Basil Slade, the architect, considered, after sounding, to be a good foundation. On this, concrete composed of blue lias lime and Thames ballast was laid to a depth of 10ft. 6in. and width 7ft. 6in. Water seemed to circulate through the gravel below a mean depth of 23ft. 6in., and the influences of the tides were felt. A pulsometer pump in a well was set to work, and the trenches drained sufficiently to allow of work being executed; after the concrete was all laid, the water was allowed to find its level. At a depth of mean level 15ft. 6in., a table-top or basement floor was laid, and a layer of Portland cement concrete 6in. thick as foundation of finished floor in granolithic or asphalt. The stratum throughout was very even, and the work progressed steadily without difficulty. There are two floors below the ground floor, both of which, the architect states, are as dry as a bone. The damp-course and retaining wall lower course was of trowelled Seyssel asphalt. The precaution was taken of putting drain-pipes in the concrete below water-level, to allow the water to pass freely through the sand and gravel within the main walls. An exhibited sketch explained the difficulties which had to be encountered. At the Surveyors' Institution, 12, Great George-street, in the new building designed by Mr. Alfred Waterhouse, architect, and built by Messrs. Foster and Dicksee, contractors, the section of strata shows 3ft. or 4ft. of made ground on top, about 4ft. black mud, 6ft. clay and brick earth, clay and sand mixed, and 3ft. gritty sand, below which is the ballast, or London gravel. In some cases the foundations were carried down 18ft. deep, but only where the principal weights of the structure occurred. A concrete (6 to 1) raft, 2ft. 6in. thick, is carried on continuous concrete walls round part of the outside and under main walls and piers of the building. Continuous concrete about 14ft. deep under the raft, and width 5ft. 6in. to suit the footings of a 2ft. 3in. wall (footings 4ft. 6in. plus 6in. concrete either side = 5ft. 6in.) All timber was removed in lengths of, say, 10ft., as the concrete filling (3ft. framing) was carried up. At the British Institute of Preventive Medicine, Chelsea Bridge-road, the foundations were carried through made ground and clay under, to a depth of 40ft. below street level; under the clay was found peat, and under the peat 5ft. to 6ft. of fine dirty sand—then ballast. A concrete raft, 3ft. 6in. thick (six to one), intervenes between the top of piers and the bottom of the brick footings. The position of the piers under the raft was settled by the cardinal points of the building, thus forming a kind of propped-up dining-table or platform with several legs. Mr. Dulac, one of the contractors for the Paris Exhibition of 1900, has endeavoured to avoid the labour of excavation and necessity of carting away bad ground; also, to save the expense of timbering and trenching by compressing and ramming the soil in the following manner:—With the aid of a steam pile-driver and the employment of rams of various shapes he forms a bore-hole, which he fills with hard substances after each stroke of the ram. Thus, in dealing with a light, friable soil, a conical ram is used, and in some cases a mushroom-headed ram is applied successfully. In this way, by forming holes about 3ft. apart, and forcing the selected material sideways into the ground surrounding the cavity, the soil is consolidated to receive a superstructure. The drop allowed for the ram depends on the nature of the ground, the operations in the case of water-logged soils being aided by the insertion of ashes mixed with quick-setting cement, intended to produce a species of tube or sheath for the passage of the ram in the driving in of further hard substances. At Victoria Station, Pimlico, the engineer to the London, Chatham, and Dover Railway, Mr. Roche, states that in recent work they have found good gravel at a depth of 16ft. from the surface, and have dug 8ft. into the gravel without passing through it. At Sion College, upon the Thames Embankment, Messrs. Foster and Dicksee state that in this foundation they went down to the London clay. The method there adopted was to have great pier holes 8ft. by 8ft. on plan, going right down to the clay, filled up with cement concrete, and

from these brick arches carrying the main walls. In cases where partly-made ground and partly water-bearing gravel are encountered, a raft of concrete, about 6ft. to 9ft. thick, has been successfully used with a gridiron of steel contained therein. The lecturer described in detail the steel construction introduced into a concrete foundation at points where main pressures occur, in the case of the building of a new front to a Congregational Chapel at Canning Town, designed by Mr. F. W. Troup, architect, where the foundations had to pass through layers of peat and clay to the ballast below and where the new front had to be constructed so as to be independent of the interior existing building. Also some premises known as Mansfield House, by the same architect, in which concrete 3ft. thick was laid as a foundation, with 8in. by 3½in. rolled steel joists, having bolts 12in. long at each end, so as to give a tie in the centre of the concrete raft in which they were embedded. Very little excavation was needed. The subsoil consists of layers of peat, peaty clay, and clay to a depth of 15ft. to 20ft., when good ballast is reached. The foundation sunk 1½in. at one corner at the back of the premises, and 2in. and 3½in. respectively at two corners of the front of the premises, but no cracks appeared in the building generally, and the sinking appears to have gone on as the building rose. One corner of the building in front overhung about ½in., but the other parts of the building appeared to remain quite vertical. At the back of the premises the top of the concrete, which was laid 9in. lower than in the front portion, was 18in. above the natural level of the ground. It is natural that the lower down the river we go, any foundation work becomes more troublesome than is generally experienced in up-river sites.

(To be continued.)

#### ART METAL-WORK EXHIBITION AT WESTMINSTER.

THE Loan Exhibition of historic metal-work now being arranged in St. Stephen's Hall at the Royal Aquarium, Westminster, in connection with the handicraft and competitions displays for wrought iron and other departments of artistic workmanship in metals, bids fair to surpass anything of its immediate kind hitherto held in London. The exhibition, too, of the trades section will be fairly representative, judging from the collection of exhibits already on view. In this preliminary notice we do not propose to enter upon anything approaching a detailed account of the exhibits; indeed, before going to press this week it would be scarcely possible to do so, as, of course, a goodly number of the best things to be shown are hardly in position. The exhibition is to be opened informally to-day; but, owing to the State obsequies of Mr. Gladstone at Westminster Abbey to-morrow, the council decided to abandon the reception originally intended in connection with the inauguration of the exhibition. The President, the Duke of Westminster, in consequence of the funeral of England's great statesman, is prevented from attending till after Whitsuntide. The judges assembled on Thursday to award the medals and prizes for the competitions drawings in artistic design. Professor Banister Fletcher, J.P., presided, and among those present were Professor Aitchison, R.A., President of the Royal Institute of British Architects; Mr. H. D. Searles-Wood, F.R.I.B.A., Mr. Hy. Longden, Mr. Sidney R. J. Smith, F.R.I.B.A., Mr. W. Hilton Nash, F.R.I.B.A., Mr. Maurice B. Adams, F.R.I.B.A., Mr. Hampden W. Pratt, F.R.I.B.A., President of the Architectural Association, Mr. Carl Krall, and several other gentlemen chosen from the Council. The Loan Exhibition, which is being arranged by the hon. sec. of the exhibition, Mr. J. Starkie Gardner, includes contributions of exquisite examples from H.M. the Queen, such as Prince Henry's suit of armour from Windsor, the Earl of Essex's half-suit, a French suit also from the Castle. The Pembroke Helm is lent by Sir Noel Paton, and the Queen sends Hampden's sword and the Cid sword, likewise from Windsor. From Parham comes a fine Gothic 15th-century suit, and Mr. Morgan Williams shows a similarly beautiful suit of same period as the last named. Sir Christopher Hatton's suit is lent by Mr. Davis, and the Duke of Norfolk lends the Becket Cup. From Penhurst a double-handed sword of Leicester's,

with Bear and Ragged Staff in chased steel, is exhibited. Major Farquharson's historical series of gun-locks and pistols is extremely interesting. The armour from the Temple and plate to be seen, to say nothing of the Italian bronzes, add considerably to the charm of the assembly of works of art. These are grouped in glazed cases, and a comprehensive and descriptive catalogue of the collection is in course of preparation as a record of the exhibition. We may, in conclusion, draw attention to five plaques from Kew Palace, illustrating Louis XIV. taking Franche Comte and Lorraine. These are lent by her Majesty. From Battle Abbey a fine gold brilliant (Gothic) is lent by Sir Noel Paton.

The Sheffield School of Art shows a fine set of high-class designs by students in the classes there for bronze, gold, and steel work. Many of these are refined, and have taken prizes at South Kensington and elsewhere.

Among the trade exhibits, to some of which we shall refer in detail later on, will be found collections by Messrs. Starkie Gardner and Co., Albert Embankment; Messrs. Drake and Gorham, Victoria-street, S.W.; Messrs. Perry and Co., Grafton-street, W.; Mr. Henry Hope, Lionel-street, Birmingham; the Coalbrookdale Company; Messrs. Burt and Potts, 38, York-street, S.W.; Messrs. Lindsay, Neal, and Co., Paddington; Mr. George Wragge, of Salford; the N.A.P. Window Company, Victoria-street; Messrs. Hayward Bros. and Eckstein, Union-street, Borough; Messrs. Strode and Co., Osnaburgh-street, N.W., and others.

#### OBITUARY.

MR. JOHN STARFORTH, architect, who was well known in professional circles in Edinburgh, died suddenly on Friday when walking along Princes-street. The fatal seizure was due to an affection of the heart. The deceased, who was seventy-five years of age, was born in Durham, and was educated at the University of his native city. Going to Edinburgh as a youth, he entered the office of Burn and Bryce, architects, and served his apprenticeship there. Subsequently he began business on his own account, and during his long professional career he enjoyed a large share of public favour. He had several of the qualities of his old master, Mr. David Bryce—not the least important of which were the knowledge and skill which he put into his designs, and the thoroughness with which he saw his work carried out. He became also a recognised authority on English Gothic; and in many of the churches which he designed the influence of Durham Cathedral, which had impressed itself upon him as a lad, made itself felt. Among other buildings of importance with which his name is associated as architect are Dumfries and Galloway Royal Infirmary, Greenock Asylum and Poor-house, Berwick Infirmary, Peebles Hydropathic, John Knox Memorial Institute, Eyre-place Church, London-road Church, Bonnington United Presbyterian Church, Moffat Parish Church (an example of Gothic adapted to Presbyterian worship), the first Kelso United Presbyterian Church, Nairn Parish Church, Holy Trinity Church, and Galashiels Free Church. He was in his day a noted church builder, and the many ecclesiastical edifices in all parts of the country which he designed are a credit to his artistic ability and taste. In a national competition for the Edinburgh Prince Consort Memorial his design received the first place, but it was afterwards abandoned for the present equestrian statue of the Prince in Charlotte-square. Mr. Starforth also gained the gold medal of the Highland and Agricultural Society for the best design for farm buildings. He was intrusted with the erection of many mansion-houses in the Highlands and West of Scotland, and with not a few of their owners he afterwards remained on intimate terms of friendship. To this his fondness for angling and shooting largely contributed. Mr. Starforth is survived by a widow, three sons, and two daughters.

SIR JOHN T. GILBERT died suddenly on Monday at Dublin, while on his way to attend a meeting of the Royal Irish Academy. As a mark of respect to the deceased, the meeting of the Academy was adjourned. Sir John Gilbert was born in 1829 in Dublin, where his father was Portuguese Consul. He was for some time Secretary of the Public Record Office of Ireland, and of the Irish Archaeological and Celtic Society; he was vice-president and honorary librarian of

the Royal Irish Academy, a governor of the National Gallery of Ireland, a member of the council of the Pipe Roll Society, and of the first council of the Bibliographical Society of London. He was also Honorary Professor of Antiquities in the Royal Hibernian Academy of Fine Arts, and a Crown Trustee for the National Library of Ireland. He was author of a history of the City of Dublin, for which he received the Cunningham gold medal, and he made numerous reports on MSS. for the Historical Manuscripts Royal Commission. In addition, he was the editor of "Facsimiles of National Manuscripts of Ireland," and a "Calendar of Ancient Records of Dublin."

MR. MEADOWS WHITE, Q.C., M.A., who recently resigned his position as Judge of the Clerkenwell County-court on account of ill-health, died on Saturday. Mr. Frederick Meadows White, who was the second son of the late Mr. John Meadows White, of Stanhope-place and Whitehall-place, was born on December 21, 1829. He was educated privately, and at Balliol and Magdalen Colleges, Oxford, of which latter College he was Fellow. He was called to the Bar at the Inner Temple in 1853, was appointed Queen's Counsel in 1877, and elected a Bencher of his Inn the following year. Mr. Meadows White was Recorder of Canterbury from 1883 to 1893, when, on being appointed a County-court Judge, he resigned that position. He was an elder brother of the late Mr. William Henry White, secretary of the R.I.B.A. from 1878 till his death last year, and had been an Hon. Associate of the Institute since 1882.

#### CHIPS.

On the 7th inst., the Lostwithiel Borough Council re-elected Mr. Robert W. Reed as their surveyor and sanitary inspector.

A parish church is being built at Glounthaune, near Queenstown Junction, from plans by Mr. S. Hyses, of Cork. The church, which will seat 1,000 persons, is built of local limestone, and consists of nave, north and south aisles, chancel, and sanctuary. Mr. J. Coffey, of Middleton, Co. Cork, is the builder, and the stained-glass windows in the chancel are by Messrs. Lavers and Westlake, of London.

The organ which has just been introduced into the Barclay Free Church, Edinburgh, was formally opened on Friday night. It is constructed on the Hope-Jones electric pneumatic system, and cost, without case, £800.

The Duke of Westminster presided over a meeting at Grosvenor House in connection with the reconstruction of the Belgrave Hospital for Children, which it is proposed to remove from Piccadilly to a site in Clapham-road, adjoining St. Mark's Church, Kennington. The sum of £4,000 was subscribed towards the cost.

The County Council's Building Act Amendment Bill, introduced to clear up doubtful points in the Act of 1894, has been approved by a Committee of the House of Commons. Special exemption is made as to building over forecourts and the height of houses in the case of the City, and by the instruction of the House of Commons the Stock Exchange was also exempted from the application of the Amended Bill.

Alderman Tolhurst, who was Mayor of Southend-on-Sea last year, has presented the borough with a Jubilee marble statue of the Queen. It represents her Majesty seated in a chair of State, in a proportion of figure which if standing erect, would be 8ft. in height. It is placed on a pedestal 10ft. high of white Carrara marble. The sculptor is Mr. J. W. Swynerton. The statue, which faces the well-known pier, was unveiled on Tuesday by Lady Rayleigh, wife of the Lord Lieutenant of Essex.

On Wednesday week at St. Anne's, Edgeside in Rosendale, at three o'clock, three stained-glass windows, which have been placed in the chancel as memorials, were unveiled. The window on the north-east represents the Shepherds visiting Mary and Joseph at Bethlehem. The central window represents Christ addressing Mary at the Sepulchre on the morning of the Resurrection. The window on the south-east represents Christ addressing the Disciples at the Supper at Emmaus on the evening of the Resurrection.

A new Wesleyan chapel is about to be built in Stoney Stanton-road, Coventry. It will be of red brick with stone dressings, will have an angle tower and spire rising to a height of 85ft., and the internal woodwork will be pitch-pine. Seats will be provided for 700 adults, and the cost of erection will be £2,910. Messrs. Harrison and Hattrell, of Hertford-street, Coventry, are the architects, and Mr. C. Garlick, jun., of Far Gosford-street, in the same city, is the contractor.

#### COMPETITIONS.

BALLYCASTLE, Co. ANTRIM.—For the drinking fountain to be erected at Ballycastle as a memorial to the late Dr. O'Connor, the design sent in by Mr. S. Kelway Pope, of Portland-street, Southampton, has been selected. The fountain will be 32ft. in height; the materials—viz., Newby granite, Portland stone, and red granite.

CRICH WATER SUPPLY.—A few months ago the Belper Rural District Council invited competitive schemes for supplying the parish of Crich with water—a district containing about 3,000 population. Ten schemes were submitted, engineers from London, Brighton, Birmingham, and Yorkshire competing. The council decided that the scheme submitted by Mr. Harry W. Taylor, A.M.I.C.E., of St. Nicholas Chambers, Newcastle-on-Tyne, and Birmingham, was the most suitable, and this was accordingly adopted. Mr. Taylor was engaged as engineer for the execution of the work. The scheme consists of pumping water from a deep well sunk in the millstone grits, into a concrete reservoir of 50,000 gallons capacity. Treble-barrel deep-well pumps, driven by gas or oil engines, will be used, the machinery being in duplicate. The cost of the scheme will be about £3,000.

OUNDE.—The committee appointed to carry out the scheme for the proposed new town-hall as the Diamond Jubilee commemoration, received, in response to the invitation, several designs from architects. It was unanimously resolved to accept the one bearing the motto "Nene," the author being Mr. J. B. Cerby, F.S.I., of Stamford. The plan provides for a central approach from West-street, with committee-rooms right and left of entrance, ticket-office, and stairs to approach the council chamber above. The main hall in the rear is about 70ft. by 22ft., having stage space, with retiring room and conveniences. The front will be of rubble stone, with freestone dressings, and the roof of grey slates; the remainder of the walls to be carried on in brickwork.

TAUNTON.—A meeting of the Market Trustees was held on Friday morning last for the purpose of receiving the report of Mr. E. W. Mountford, F.R.I.B.A., of London, the assessor appointed to make the awards for plans for the proposed town-hall. The meeting was a long one, and produced much discussion. In his report, Mr. Mountford said that of the thirteen sets of plans sent in, half a dozen at least were far in excess of the average of plans which were generally sent in for such a competition, while he particularly mentioned one or two as being about the best he had ever seen. The plans were lettered from A to L, according to the date of receipt, and he awarded the premiums to those marked A, H, and L in the order named. The design marked E was in many respects one of the best, but it failed in regard to provision for shops and market. A committee reported that after viewing the plans they were practically unanimous in deciding to recommend the trustee to adopt the award of Mr. Mountford. After discussion, it was decided to hold an adjourned meeting "to accept the awards of Mr. Mountford, and to negotiate with the architect who has obtained the first prize with a view to carrying out the work." On opening the envelopes with the names of the architects, "A" proved to be by Messrs. Samson and Cottam, of Hammett-street, Taunton, an announcement received with applause. The second prize was won by Mr. J. M. Brydon, F.R.I.B.A., Adelphi, London, and the third by Mr. Henry T. Hare, A.R.I.B.A., of Bloomsbury, London. The other competing architects were:—Messrs. Gibson and Russel, Grey's Inn-square, London (who sent in plans marked "E," which were highly spoken of by Mr. Mountford); Messrs. Tapper and Crouch, Grey's Inn-square, London; Mr. Knill Freeman, Bolton; Messrs. C. Silcock and Reay, Bath; Messrs. J. Houghton Spence and J. T. Bell, Taunton; Messrs. Mallows and Grocock, Bedford; Mr. W. H. Crease, M.S.A., Bristol and Taunton; Mr. G. Elkington, F.R.I.B.A., 95, Cannon-street, London; Mr. C. Henman, 64, Cannon-street, London; and Messrs. Murray and Foster, London. It was decided to publicly exhibit the competitive plans until Wednesday in this week in the Parade Assembly-room. The style adopted by Messrs. Samson and Cottam is of the Renaissance period. The amount of money at the disposal of the trustees for building purposes is not sufficiently large to admit of great elaboration of the design. The building will cover the

whole of the space at present occupied by the old Market House and its adjoining structures. It will also extend forward for a considerable distance upon the Parade. Red brick and terracotta will enter largely into the construction of the outer walls of the building, and relief will be given to the structure by a row of stone columns running along the principal frontage, which will face the Parade and consequently look straight up North-street. At each end of the main front there will be a massive square turret, and a stone balcony will run from one turret to the other above the tier of columns previously mentioned. The turrets will also be relieved with Corinthian columns in their upper parts, whilst the lower will be formed entirely of stone. A clock-tower will rise from the centre of the roof. At the rear, in Fore-street, provision has been made for a dozen lock-up shops to run along the entire length of the building. On the ground floor there is, firstly, a covered market in the centre for florists and greengrocers. At the eastern end of the market there will be a guild-hall, and at the opposite end wine and spirit merchants' offices and stores, the present tenants of a portion of the old market house. On the first floor will be an assembly-room 94ft. by 62ft., with a stage about 30ft. by 25ft., orchestra, &c. Four dressing-rooms are provided in connection with the stage, and it is suggested that the ceilings of the stage be constructed of light framework made easily removable, so as to give ample space for wings and flies when the hall is used for theatrical purposes. There are four staircases for the use of the general public, and one staircase for use in connection with the stage. The entrance to the assembly-room will be on the east side of the building, facing the Jellalabad Monument.

WOLVERHAMPTON.—At a private meeting of the Board of Guardians, on Friday, convened to consider the question of the new workhouse, and the recommendation of the General Purposes Committee, that only three architects be allowed to supply plans for the new building, it was decided that the whole of the architects in the Wolverhampton Union be allowed to compete.

The foundation stones of a new Wesleyan chapel, at Elmswell, West Suffolk, were laid on Monday. Messrs. Eade and Johns, Ipswich, are the architects, and Messrs. Hogg and Son, Coney Weston, the builders. The outlay will exceed £500.

Mr. G. Wilcocks, M.Inst.C.E., attended at the Guildhall, Walsall, on the 19th inst., and conducted an inquiry on behalf of the Local Government Board with reference to an application to sanction a loan of £1,000 for the widening of the thoroughfare in George-street, and £700 for the public baths.

William Jeffrey, 56 years of age, master painter and decorator, was killed at Eccles on Thursday in last week. He had to paint the back bedroom window of a house in Cannon-street, and his ladder being short he tied an old one to it. While standing on the old portion, at a height of 14ft., the ladder broke, and he fell to the flags, receiving injuries from which he died immediately.

The Local Government Board has sanctioned the borrowing by the Barton Rural District Council of £1,130, and by the Urmston Urban Council of £2,374, for the extension and improvement of the joint sewage disposal works at Flinton. Mr. C. C. Hooley, C.E., surveyor to the former council, has just completed the construction at Davyhulme of a bacteria filter-bed to prevent the pollution of Bent Lanes Brook.

A county museum for Hertfordshire is about to be built at St. Alban's, on a site given by Earl Spencer. Mr. Arthur S. Flower, M.A., F.S.A., is the architect of the building, which will be built in sections as funds allow. The portion now to be built will comprise the main entrance hall and staircase, lecture-room and library, curators' room, and museum. Larger galleries will be erected as the funds come in and specimens accumulate. Selected firms of Hertfordshire builders are to be asked to submit tenders for the work.

Mr. W. O. E. Meade-King, M.I.C.E., Local Government Board Inspector, held an inquiry at the Birkenhead Town Hall on Friday respecting an application by the corporation to borrow £13,000 for new public baths and washhouses.

The Right Rev. Dr. Isley, Roman Catholic Bishop of Birmingham, laid the foundation-stone of a new church, dedicated to Our Lady of the Angels and St. John the Evangelist, at Princethorpe, near Rugby. The church is being erected by Messrs. Foster and Dicksee, of Rugby, to designs by Mr. P. P. Pugin, architect, of London.

CONTENTS.

Natural Art .....	731
Model Specifications.—XIV. ....	731
Cheap Paints and Pigments.—II. ....	733
The Architectural Association .....	735
American and English Steel Construction .....	736
Ironwork at South Kensington Museum.—III. ....	736
Concrete Slabs.....	736
The Collapse of Abbey Mansions, Westminster .....	736
Foundations as Applied to London Buildings and Riverside Foundations .....	739
Art Metal-Work Exhibition at Westminster .....	741
Obituary .....	741
Competitions .....	742
The BUILDING NEWS Directory.....	743
Our Illustrations .....	743
Building Intelligence .....	762
Intercommunication .....	762
Professional and Trade Societies .....	763
Parliamentary Notes .....	763
Water Supply and Sanitary Matters .....	763
Statues, Memorials, &c. ....	764
Legal Intelligence .....	764
Our Office Table .....	764
Meetings for the Ensuing Week .....	764
List of Competitions Open .....	765
List of Tenders Open .....	765
Trade News .....	768
Latest Prices .....	768
Tenders .....	769

ILLUSTRATIONS.

PARK MANSIONS, ALBERT GATE.—NEW WORKHOUSE BUILDINGS, SHOREHAM.—NO. II. THAMES STREET, WINDSOR.—“GLENROY,” FINCHLEY.—GLASGOW CATHEDRAL.—FOREST LODGE, TULSE HILL.—RANDOLPH HALL, CAMBRIDGE, MASS.

Our Illustrations.

PARK MANSIONS, ALBERT GATE.

THIS building, now in course of erection at the junction of Kensington and Brompton roads, will cover an area of about 36,000sq.ft. The ground floor (as will be seen by the plan) will consist of 38 shops, with light showrooms on mezzanine floor over, and also well-lighted stores in basement, with ample lavatory accommodation. There will be a central arcade from Kensington-road to Brompton-road, and a fully-licensed hotel (known as the Paxton's Head), and also a licensed café, will be incorporated in the new building. The six upper floors will consist of 114 self-contained flats of from two to six rooms each, with bath-room, larder, and coals. The small suites are intended for the occupation of members of clubs and bachelors, and on the top floor will be a service-room, and a large kitchen fitted with every requisite. There will also be a service lift to each floor. Three staircases furnish the means of access to the first and all floors above. In the well-hole of each will be provided a hydraulic passenger elevator. There will also be two additional staircases for the servants, and goods lifts. The whole of the building will be of fire-proof construction, and the elevation will be executed in Bath stone and red bricks, with red granite pilasters. The builder is Mr. A. Kellett, of Old Oak Wharf, Willesden, and the architect is Mr. G. D. Martin, 3, Pall Mall East, S.W.

NEW WORKHOUSE BUILDINGS, SHOREHAM, BRIGHTON.

THE guardians of the Steyning Union (which includes the west end of Brighton, besides a large rural district), having acquired an extensive site on the Upper Shoreham-road, are about to build a new workhouse, which, while arranged and constructed with regard to economy both in first cost and administrative expenditure, shall provide all that experience has found to be best in arrangement, fitting, and other details. With this end in view, a sub-committee, accompanied by the architects, have visited many of the metropolitan and county workhouses, and the buildings which we illustrate to-day are the result of these investigations. They will include tramp-wards and receiving-wards in the entrance block, with dining-hall, kitchens, masters' and matrons' administrative departments, from which, by covered corridors, the various workhouse pavilions, &c., will be reached. The scheme also provides for an extensive laundry, workshops, boiler-house, stabling, and other accessories. The heating, sanitary, and cooking arrangements have been especially studied, and the buildings are so arranged as to be capable of easy extension without any sacrifice of executed work. The whole of the buildings have been designed by the archi-

itects to the board, Messrs. Clayton and Black, of Brighton.

NO. II. THAMES-STREET, WINDSOR.

THIS house is situate in Thames-street, Windsor, and opposite the Castle walls. The view shows the house from Thames-street, but only the left-hand upper part of front has lately been altered. The rear of the building has been entirely rebuilt, the business premises being kept absolutely distinct from the private-house portion. Access is gained to the private house by a flight of stone steps from lobby in Thames-street, which lead up to a small square hall. As shown by plans, there are three sitting-rooms, together with kitchen and offices, on this floor, with separate trades staircase in rear. On second floor there are four bedrooms, bathroom, dressing-room, &c., and three rooms in attic. Messrs. Hollis and Sons, of Windsor, were the builders, and the works have been carried out under the superintendence of, and from the designs of, Mr. Ernest R. Barrow, A.R.I.B.A., architect, London.

“GLENROY,” FINCHLEY.

THE illustrations of “Glenroy” represent additions to a house built from plans by Mr. E. W. Poley, architect, some few years ago, consisting, as shown by the plans, of a billiard-room, offices, and servants' stairs on ground floor, three bedrooms on the first floor, and commodious coal, wine, and other offices in the basement. The contractor is Mr. C. Plowman, of West Finchley, N.

GLASGOW CATHEDRAL.

WHEN illustrating the general view of this building and an interior sketch by Mr. Herbert Railton of the rood-loft in the BUILDING NEWS for May 13th, we directed the attention of our readers to the capital volume just issued by Messrs. Morison Bros., of Renfield-street, Glasgow, under the title of “The Book of Glasgow Cathedral.” Pressure on our space on that occasion prevented the inclusion of the accompanying drawings by Mr. D. Small from the same building, but we promised to refer again to the matter. The view given of the choir, looking from the aisle, shows the excellence of the architectural design which it illustrates. The clumsy seats which pack both aisles are most objectionable, destroying the effect of the wall arcades, and spoiling in no little degree the proportions of this part of the church. The whole of the choir is filled with needlessly high pews, and the sacarium is now fitted up, of course, for use as a Presbyterian place of worship. The aisles are vaulted, but the main body of the church was designed to have a wooden roof. The capitals of the arcade piers are richly carved; but the foliations have been patched with cement in a most unwarrantable manner. Much damage has been done here, as elsewhere, by ignorant over-restoration. The triforium is of a type frequently met with, and is of excellent character, of the Lanet period. The peculiar position of the Chapter-house at the north-east corner of the choir is to be noted. Its only access is from the lower church. The sacristy is placed over it, with a door into the east aisle of the choir, and a staircase in a turret provides means of communication between the sacristy and the Chapter-house, also between the upper and lower churches at this point. The variations in the details of the design of this Chapter-house building as compared to those of the choir, go far to record its date of execution. Here we have the same base as that of the choir, and the same windows, narrow lancets with clustered shafts in the jambs and between the two lights—a perfect 13th-century elevation—and yet “there can be little doubt,” says Mr. Honeyman, “that this building as it now stands was not completed till the 15th century.” It may have been completed in the 13th century, and, with the hall of the vicar's choral, subsequently ruined by violence or accident, but it is difficult to believe that a Chapter-house was begun in 1230 and left unfinished for nearly two centuries. There is hardly a trace of Perpendicular work in Glasgow Cathedral, and yet when this Chapter-house was finished the Perpendicular style was fully developed in England. We thus see how extremely interesting this work becomes. The sections given in the volume add to its value.

FOREST LODGE, TULSE HILL, S.W.

THIS house, the residence of Mr. G. Adney Payne, has been refronted and much added to in

a handsome way by Messrs. Wimperis and Arber, the architects. The plan has been remodelled. One of the chief improvements consists of a richly-designed library, of which we hope to give an illustration shortly. The bookcases and the fireplace are the chief features in the apartment, which is furnished in oak, with bronze fittings. The entrances to the carriage-drive are formed by a fine pair of wrought-iron gates. The drawing illustrated by us to-day shows the porch and new facade. The house, as advertised elsewhere, will be offered for sale by auction on June 9, by Messrs. Stimson and Sons, of 8, Moor-gate-street, E.C.

RANDOLPH HALL, CAMBRIDGE, MASS.

THIS large block of students' quarters is now in course of erection as a private dormitory building for Harvard University. Each study has two bedrooms in connection with it, and a bath-room and w.c. A couple of large breakfast-rooms with kitchens are contrived on the ground floor, where the janitor's quarters are located. The two views given herewith and the plans sufficiently illustrate the work, which is treated in a simple and broad manner architecturally. Messrs. J. R. Coolidge, jun., and V. Wright are the architects. The buildings are to be finished for occupancy next year. We are indebted to the *American Architect* for the accompanying drawings.

CHIPS.

It has been decided to erect a new church at Ravensthorpe, in the diocese of Wakefield. The cost is estimated at £10,000, and towards this an anonymous gift of £3,000 has been received.

The Government of India has decided that in future officers of the Royal Engineers should invariably be employed in designing the construction and making the periodical inspections of fortified frontier forts and posts, this provision being held to be most necessary as a military precaution.

At the last meeting of the Mersey Docks and Harbour Board, the chairman, Mr. John Branker, was presented with his portrait in oil by his colleagues on the Board. Mr. Branker afterwards presented the portrait to the Board, and it is to occupy a permanent position in the Board-room. The portrait is the work of Mr. R. E. Morrison, of Liverpool.

The Mumbles Pier, just opened by Lady Jenkins, has been erected by the Mumbles Railway and Pier Company, at a cost of over £16,000. It runs out from a part underneath the rocks just beyond the Mumbles village for about 830ft., so as to accommodate steamers at low tide. The pier is constructed of iron. It has a centre widening of 60ft. by 40ft., and the head is 135ft. by 84ft. The neck portion is 25ft. wide, and has two enlargements opening to 37ft. Around the pier-head a landing-stage, constructed of wood and entirely separate from the pier itself, has been constructed with platforms, landings, and steps.

A rood screen has just been placed in the village church at Down Ampney, Wilts, from designs by Mr. C. E. Ponting, F.S.A., of Marlborough. It is 15th-century in style and executed in oak, enriched by gilding. The whole of the sanctuary has been laid with marble. The church has been seated throughout in oak, as also has the side chapels. The south chapel has been inclosed with screens, the altar foot pace laid with many coloured marbles, and the old tombs restored. The whole of the work has been carried out from the designs and under the direction of Mr. Ponting by Messrs. Harry Hems and Sons, of Exeter.

At Christie's, on Saturday, the greater portion of the important collection of pictures formed by the late Mr. Joseph Ruston, of Lincoln, was sold. The total amount realised was £43,000. The pictures which brought the highest prices included three by D. G. Rossetti—the “Veronica Veronese,” 1,550gs.; “Dante at the Bier of Beatrice,” 3,000gs.; and “La Ghirlandaja,” 3,000gs. Two of Sir E. Burne-Jones's “The Mirror of Venus,” 5,450gs.; and “The Chant d'Amour,” 3,200gs. One of Mr. G. F. Watts's “The Eye of Peace,” 1,350gs.; a Rembrandt, a portrait of Nicholas Ruts, 5,000gs.; and a Gainsborough, a portrait of Lady Clarges, 1,850gs.

The Earl of Jersey and Colonel Boughey, R.E., held, on Thursday and Friday in last week, an inquiry at Colwyn Bay touching an application to the Board of Trade for the construction of a light railway, eight and a half miles in length, between Llandudno and Colwyn Bay, the gauge being 3ft. 6in., the plan on the overhead system and worked by electricity, the estimated cost being £67,000. Mr. Dickenson, C.E., the engineer of the scheme, explained the plans, and the commissioners stated that they had recommended that the order be granted.





RANDOLPH HALL, CAMBRIDGE, MASS.  
 J. R. COOLIDGE, JR., & V. WRIGHT, ARCHITECTS.

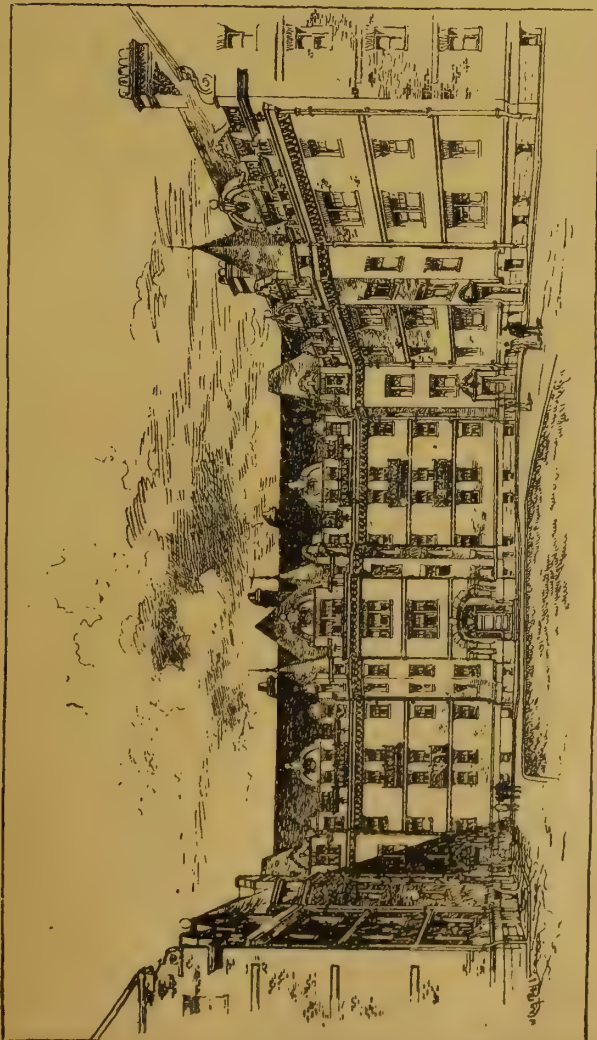

GROUND FLOOR PLAN

SECOND FLOOR PLAN

## Building Intelligence.

**HIGHWORTH.**—New mixed schools, erected by the Highworth School Board, were formally opened last week. They are Modern Gothic in style, and are faced with red pressed bricks, the tracery, mullions, and dressings being of Guiting stone from the Tally-ho quarry near Nutgrove, Oxon, while the roof, which is of high pitch, is covered with Bangor Lady slates. The accommodation is on one floor, and consists of five classrooms leading off a central hall, the whole being designed for 360 children. The system of heating introduced is that of Grundy's M.B. hot-air grates, and provision has been made for the ventilation of the different rooms by means of a series of Boyle's fresh air inlets and extractions. The playgrounds, which have been levelled and gravelled, are of ample size, the whole site acquired by the board being  $1\frac{1}{2}$  acres in extent. In the centre of the playgrounds and detached from the main structure, are playsheds for both girls and boys, with offices adjoining. The cost of the building, of which Messrs. Bishop and Pritchett, F.S.I., Swindon, were the architects, has been £4,400, and the work has been carried out by Mr. Joseph Thomas, of Highworth.

**NORTHAMPTON.**—A special meeting of the Northampton Union of Baptist Churches has been held for the purpose of receiving the builders' tenders for the new Baptist Chapel in Adnitt-road, Monk's Park. A Sunday-school will be afterwards built on an adjoining site, with a frontage in Lea-road. A number of architects were invited to prepare plans, and a London assessor selected the design of Messrs. Mosley and Anderson, of Abingdon-street, as being the best and most suitable. The main building will consist of nave, with gable-end transepts, and with an aisle on either side. The aisles have lean-to roofs. The nave is lighted, not only from the windows in front, but from the windows in the half-timbered clerestory. The baptistry is immediately in front of the rostrum. Behind, separated from the chapel proper by an internal passage, are the vestries. The chapel will accommodate about 450 worshippers. Five Northampton builders were invited to tender, and these tenders, when opened, were found to be exceedingly close, only about £100 separating the highest from the lowest. The tender of Mr. A. P. Chown for £1,475, the lowest figure, was accepted.

**TRURO.**—At the eighteenth annual meeting of the Cathedral Union of Truro, held on Friday, Canon Wortledge, hon. secretary, reported the twelvemonths expenditure, plus the deficit of £120 with which the year began, was £1,187, and the total income from all sources £1,115. Mention was made of the donation of £500 by an anonymous donor, by whose generosity £500 had been also given to the Cathedral Building Fund. It has been invested in existing annuities, and will produce an annual income of about £15 to the permanent maintenance fund of the cathedral. First payment of £111 has also been made under the Archdeaconry of Cornwall Act, 1897, by the Ecclesiastical Commissioners towards the maintenance fund. It was announced that in a short time the building of the nave would be recommenced. Towards this work £27,000 had already been raised, and another £8,000 is needed to complete the work.

On Wednesday week a new Wesleyan chapel, situated in Sydney-street, Burton-on-Trent, was formally opened. The edifice is Gothic in style, and will seat between 400 and 500 people. It is faced with pressed bricks with Hollington stone dressing, and the woodwork is of red deal. The cost was about £1,300. Mr. C. F. Underhill, of Burton, was the architect, and Mr. J. Harlow the contractor.

By order of the First Commissioner of Works, in accordance with the commands of the Queen, the grounds of the Ranger's Lodge at Greenwich and the Royal Palace at Kew will henceforward be opened to the public; and the grounds of the Queen's Cottage at Kew were also formally added to Kew Gardens on Saturday.

Earl Beauchamp opened an exhibition of pictures at the Bermondsey Settlement, Farncombe-street, Jamaica-road, on Tuesday afternoon. The exhibition comprises 174 pictures, which occupy the lecture-hall, reception-room, and one of the largest classrooms. The exhibition will be opened free from 10 a.m. to 10 p.m. each day till Saturday in next week, June 4.

### TO CORRESPONDENTS.

[We do not hold ourselves responsible for the opinions of our correspondents. All communications should be drawn up as briefly as possible, as there are many claimants upon the space allotted to correspondents.]

It is particularly requested that all drawings and all communications respecting illustrations or literary matter should be addressed to the EDITOR of the BUILDING NEWS, 392, Strand, W.C., and not to members of the staff by name. Delay is not unfrequently otherwise caused. All drawings and other communications are sent at contributors' risks, and the Editor will not undertake to pay for, or be liable for, unsought contributions.

Cheques and Post-office Orders to be made payable to THE STRAND NEWSPAPER COMPANY, LIMITED.

### TERMS OF SUBSCRIPTION.

One Pound per annum (post free) to any part of the United Kingdom; for Canada, Nova Scotia, and the United States, £1 6s. 0d. (or 6dois. 90c. gold). To France or Belgium, £1 6s. 0d. (or 33fr. 90c.) To India, £1 6s. 0d. To any of the Australian Colonies or New Zealand, to the Cape, the West Indies, or Natal, £1 6s. 0d.

### ADVERTISEMENT CHARGES.

The charge for Competition and Contract Advertisements, Public Companies, and all official advertisements is 1s. per line of Eight words, the first line counting as two, the minimum charge being 6s. for four lines.

The charge for Auctions, Land Sales, and Miscellaneous and Trade Advertisements (except Situation advertisements) is 6d. per line of Eight words (the first line counting as two), the minimum charge being 4s. 6d. for 40 words. Special terms for series of more than six insertions can be ascertained on application to the Publisher.

Front-page Advertisements 2s. per line, and Paragraph Advertisements 1s. per line. No Front-page or Paragraph Advertisement inserted for less than 5s.

Advertisements for the current week must reach the office not later than 3 p.m. on Thursday. Front-page Advertisements and alterations in serial advertisements must reach the office by Tuesday morning to secure insertion.

### SITUATIONS.

The charge for advertisements for "Situations Vacant" or "Situations Wanted" is ONE SHILLING FOR TWENTY-FOUR WORDS, and Sixpence for every eight words after. All Situation Advertisements must be prepaid.

### NOTICE.

Bound copies of Vol. LXXIII. are now ready, and should be ordered early (price Twelve Shillings each), as only a limited number are done up. A few bound volumes of Vols. XXXIX., XL., XLI., XLVI., XLIX., LI., LIII., LVIII., LIX., LXI., LXII., LXIII., LXIV., LXV., LXVI., LXVII., LXVIII., LXIX., LXX., LXXI., LXXII. may still be had, price Twelve Shillings; all the other bound volumes are out of print. Most of the back numbers of former volumes are, however, to be had singly. Subscribers requiring any back numbers to complete volume just ended should order at once, as many of them soon run out of print.

RECEIVED.—P. K. and Co.—G. D.—A. W.—L. N.—M. R. and Son.—N. S.

## Intercommunication.

### QUESTIONS.

[11958.]—**Electric Accumulator.**—(1) How large would accumulator have to be to drive a bicycle, with weight of 11 stone, 12 miles. (2) How long would it require to charge it with  $\frac{3}{4}$ H.P. gas-engine? (3) What would be its weight, and what would be its price? (4) How often can accumulators be used? (5) What size and price of dynamo for charging accumulator?—**VERAX.**

[11957.]—**Breweries.**—Can any readers inform me if there is a good book published on the construction of breweries, or if any articles have appeared on this subject?—**T. W. HOOLEY, F.R.I.B.A.**

[11958.]—**Stone Lintels and Architraves.**—Will a practical mason explain how a lintel of Portland stone, 5ft. long between supports, can be jointed without visible joints, and where should the joints be placed, or would one long stone be better?—**YOUNG ARCHITECT.**

[11959.]—**Fixing Columns.**—Stone columns of three-quarter projection are required for an ashlar front, and I should like to have the opinion of any practical reader as to the mode of fixing them, or whether they should be bonded to the wall, or let into a hollow; also if the frustra ought to be dowelled together?—**T. L.**

[11960.]—**External Wall.**—A and B are adjoining owners. B wishes to raise his building and build an adjoining wall close to A's wall, which is a party-wall. Is B compelled to give A notice of the raising of his wall? It is built on his ground by the London Building Act.—**OWNER.**

### REPLIES.

[11954.]—**Water in Gaspipes.**—In all cases gas-pipes should be made to fall; but the direction of such fall must be guided by the circumstances of each system of pipes. If the meter is a wet meter the pipes are best laid falling to, same as mentioned in the query. Should the meter be a dry one, the water which condenses in the gas-pipes must be kept out of the same, or otherwise it will damage the internal fittings. Preparation must be made in this case for the water to fall into a drop-pipe, with emptying tap attached, the supply-pipe from meter being branched into the side of this pipe. Branches to

gasaliers should be short as possible, and be taken from the top of the gas-main pipe, the main-pipe being run past the gasalier with the end soldered up to form a receptacle for any water formed. Receptacles of this form should also be arranged on gas-pipes crossing floors in a direction contrary to the direction of the joists. Not less than  $\frac{1}{2}$ in. branches should be laid to all lights. All horizontal pipes along sides of joists or bare walls should be carried upon wood grounds, or strips of timber nailed to the joist. This prevents sagging of the pipes, which almost invariably cause jumping gas-lights at certain periods.—**PLUMBER.**

### CHIPS.

A new Bible Christian Church, in Stanford-avenue, Brighton, was opened on Friday.

The parish church of Old Fletton, Hants, is about to be restored from plans by Mr. Wm. Boyer, of Peterborough.

The offices belonging to the board of guardians, at Hunslet, near Leeds, are about to be enlarged at a cost of £1,660, from plans by Mr. Richardson, architect, of Rothwell. Separate accommodation will be provided for the board of guardians, the Hunslet Rural District Council, and the local board of overseers.

The application for discharge from bankruptcy of Thomas and Walter Cross, of Warrington, builders, has been refused.

At the monthly meeting of the council of the Hampstead Antiquarian and Historical Society on Thursday in last week, attention was called to the fact that the demolition of some of the old houses in Church-row had been commenced that day, with a view to the erection of flats on the site of the houses in question. Arrangements were made by the council for photographs to be immediately taken of the houses about to be pulled down.

Sir John Wolfe Barry, President of the Institute of Civil Engineers, and Mr. William Matthews, C.E., of London, paid an official visit to the North Pier at Tynemouth, on Friday afternoon, and made an inspection of the structure, with special reference to the damage caused by the storm in March last. They were accompanied by Mr. C. B. Goldson, chief assistant engineer, and Mr. C. X. King, assistant engineer, to the River Tyne Commissioners.

Colonel J. T. Marsh, R.E., Local Government Board Inspector, held an inquiry in the council room, at the town offices, Littlehampton, on Friday, respecting applications made by the urban district council for sanction to borrow £300 towards defraying the cost of the erection of a public convenience on the green near the pier and £600 for the purposes of storm-water drainage.

The Bishop of Beverley, on Saturday afternoon, conducted a service at Swinton, near Rotherham, where the Hon. H. W. Fitzwilliam performed the stone-laying ceremony in connection with the restoration of St. Margaret's Church. The church, with the exception of the tower, was destroyed by fire in March, and the contract for the restoration was let for £5,000. Mr. E. Isle Hubbard, M.S.A., of Rotherham, is the architect.

The urban district council of Yardley decided on Tuesday to take steps to obtain plans and specifications for new offices to be built on a site already purchased in Stratford-road, Sparkhill.

The properties offered at the Auction Mart last week varied very much in character, and have included country residences and estates, City and West End freeholds and leaseholds, Metropolitan and suburban investments, ground-rents, &c., and for all classes the demand was up to the best average. The aggregate realisation was £238,160, upwards of £100,000 in excess of the returns registered for the corresponding week in 1897.

Services in connection with the opening of a new Primitive Methodist Chapel and Sunday-school at the Birks, Morley, took place on Saturday. The premises have been built at a cost of £1,600, from designs prepared by Mr. T. A. Buttery, Morley, and accommodation is provided in the chapel for 250 adults, and in the schoolroom underneath for 300 scholars. Morley stone has been used in the erection of the building, and the woodwork is in pitchpine, varnished.

The chapel which has been erected at Llangefni as a memorial to the Rev. Christmas Evans, the well-known Welsh Baptist divine, was opened on Sunday. The cost of the building was £2,000. The architect is Mr. Evan Evans, Carnarvon, and the works were carried out by Messrs. R. and J. Williams, Upper Bangor.

The funeral of Mr. Hugh Jones, builder, 20, Globe-street, Walton, near Liverpool, took place on Saturday at an old Cemetery. The deceased was a well-known and respected inhabitant of Kirkdale for over a period of 50 years.

A brick and tile company has been formed at Kerby, near Gainsborough, with a share capital of £2,000. Ground has been purchased from Mr. Wm. Woods, and a modern plant laid down. The works will be in full operation in a few days.



THE BUILDING NEWS, MAY 27, 1898.

PARK MANSIONS, ALBERT GATE.  
S. W.

G. D. MARTIN,  
Architect.

SCALE OF 1" = 20' FEET

FIRST FLOOR PLAN

KEY

- 1. Shop
- 2. Office
- 3. Restaurant
- 4. Cafe
- 5. Entrance to suites
- 6. Entrance to shops
- 7. Area
- 8. Passage
- 9. Staircase
- 10. Lift
- 11. Passage to shops
- 12. Passage to suites
- 13. Passage to shops
- 14. Passage to suites
- 15. Passage to shops
- 16. Passage to suites
- 17. Passage to shops
- 18. Passage to suites
- 19. Passage to shops
- 20. Passage to suites

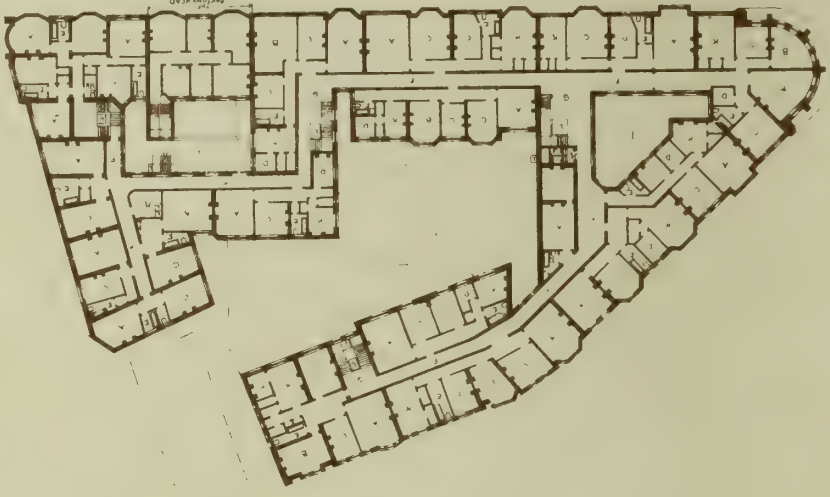

SCALE OF 1" = 20' FEET

RIGHTS RESERVED



BOOKINGTON ROAD

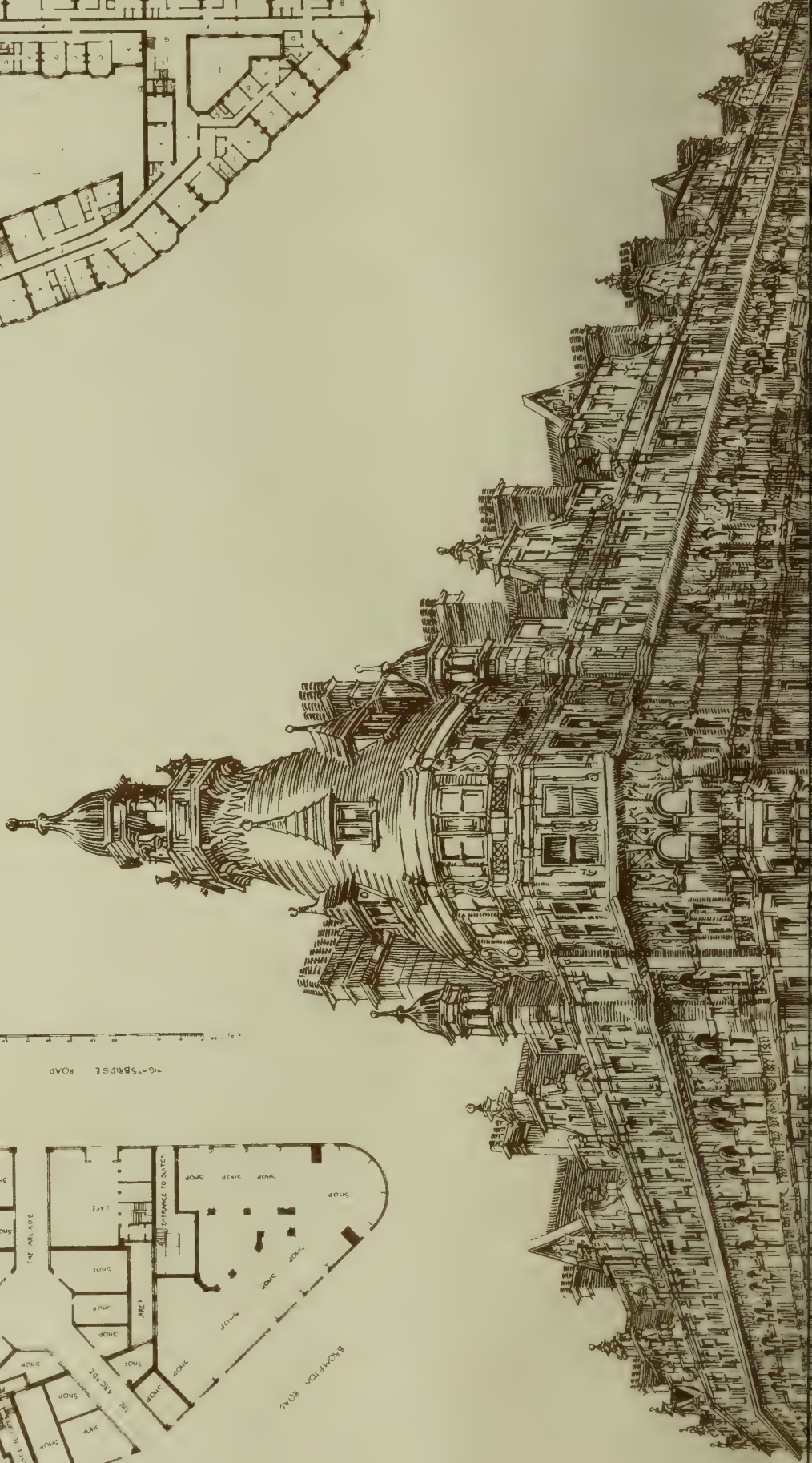



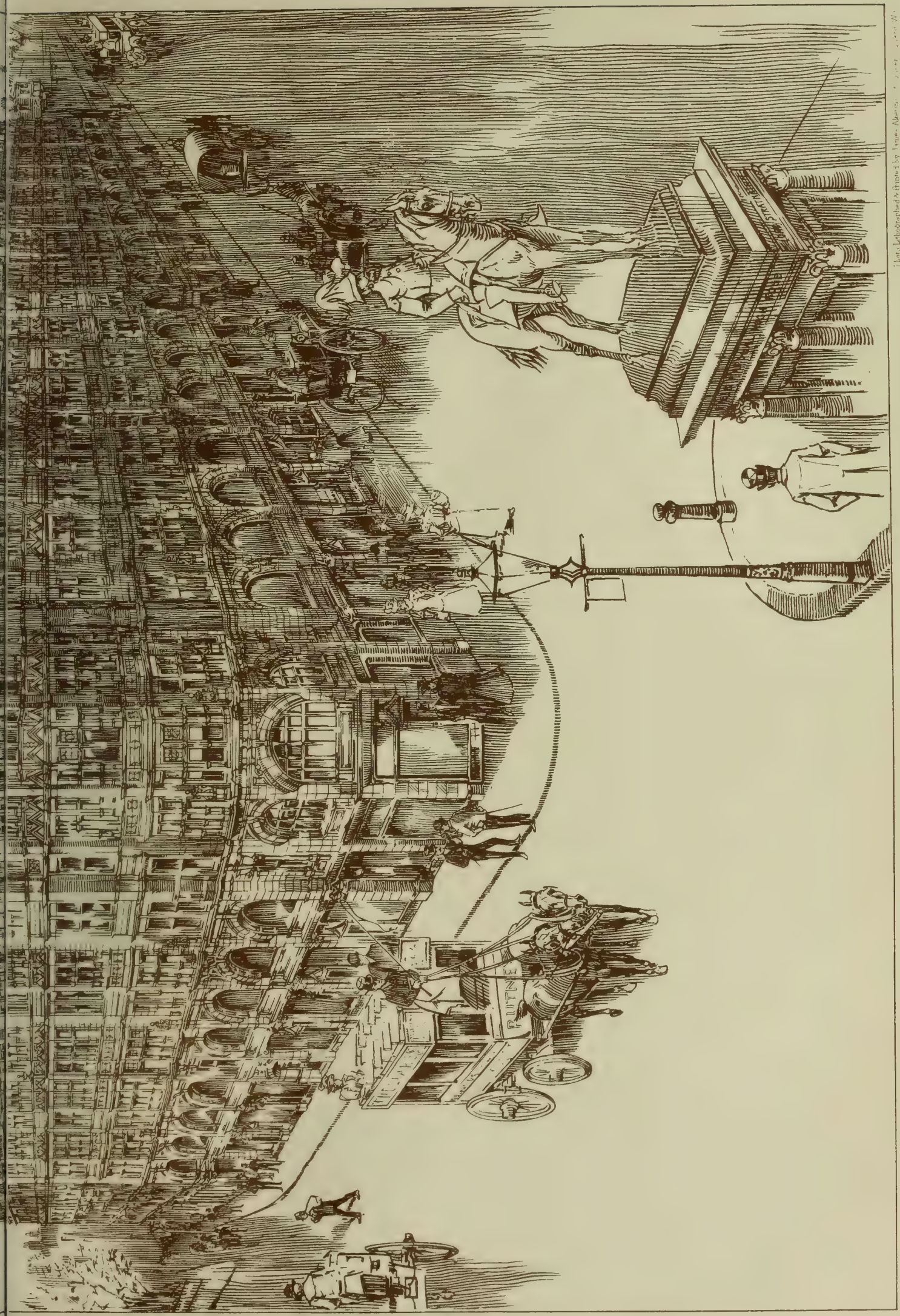





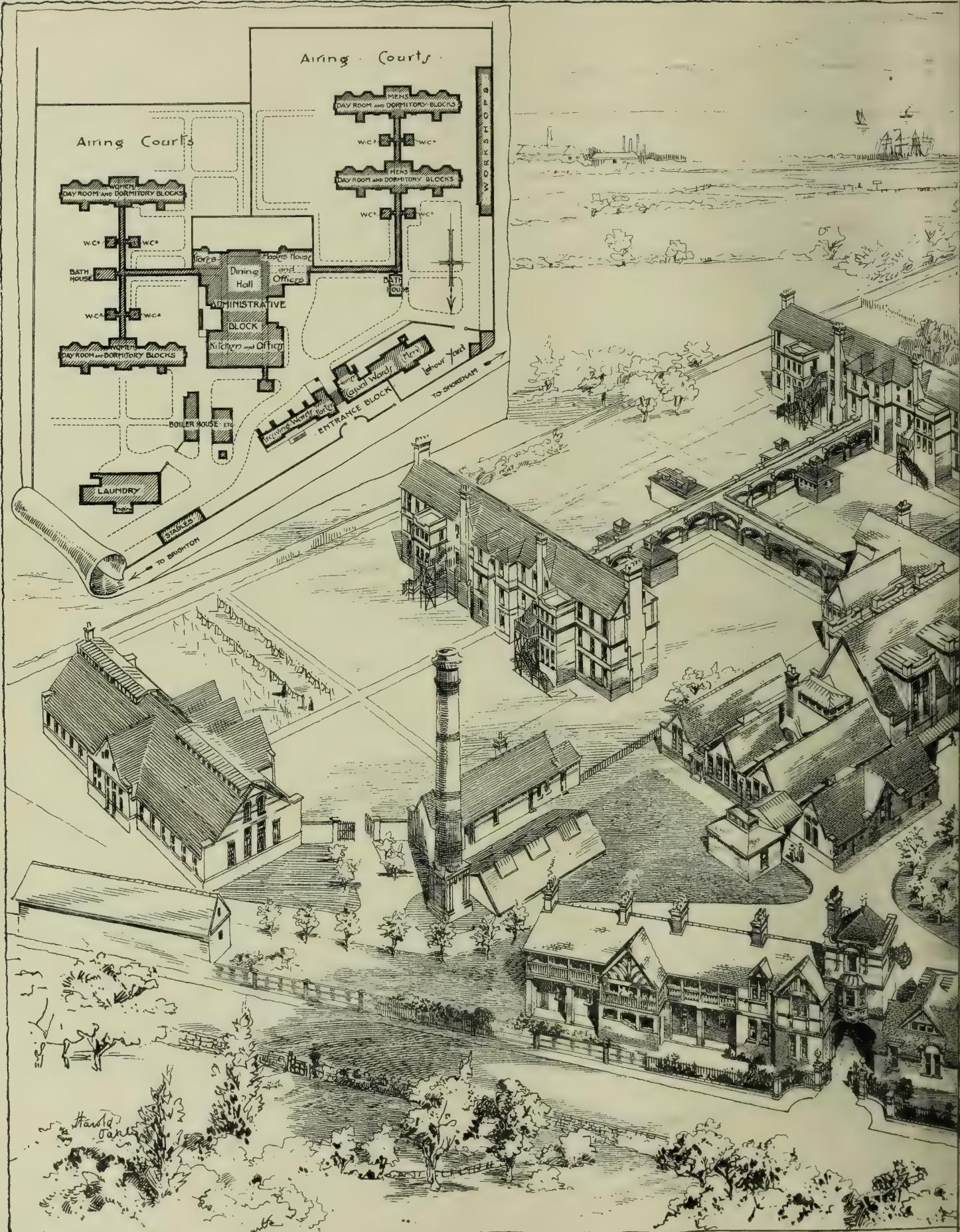

1898. MAY. 27, 1898.

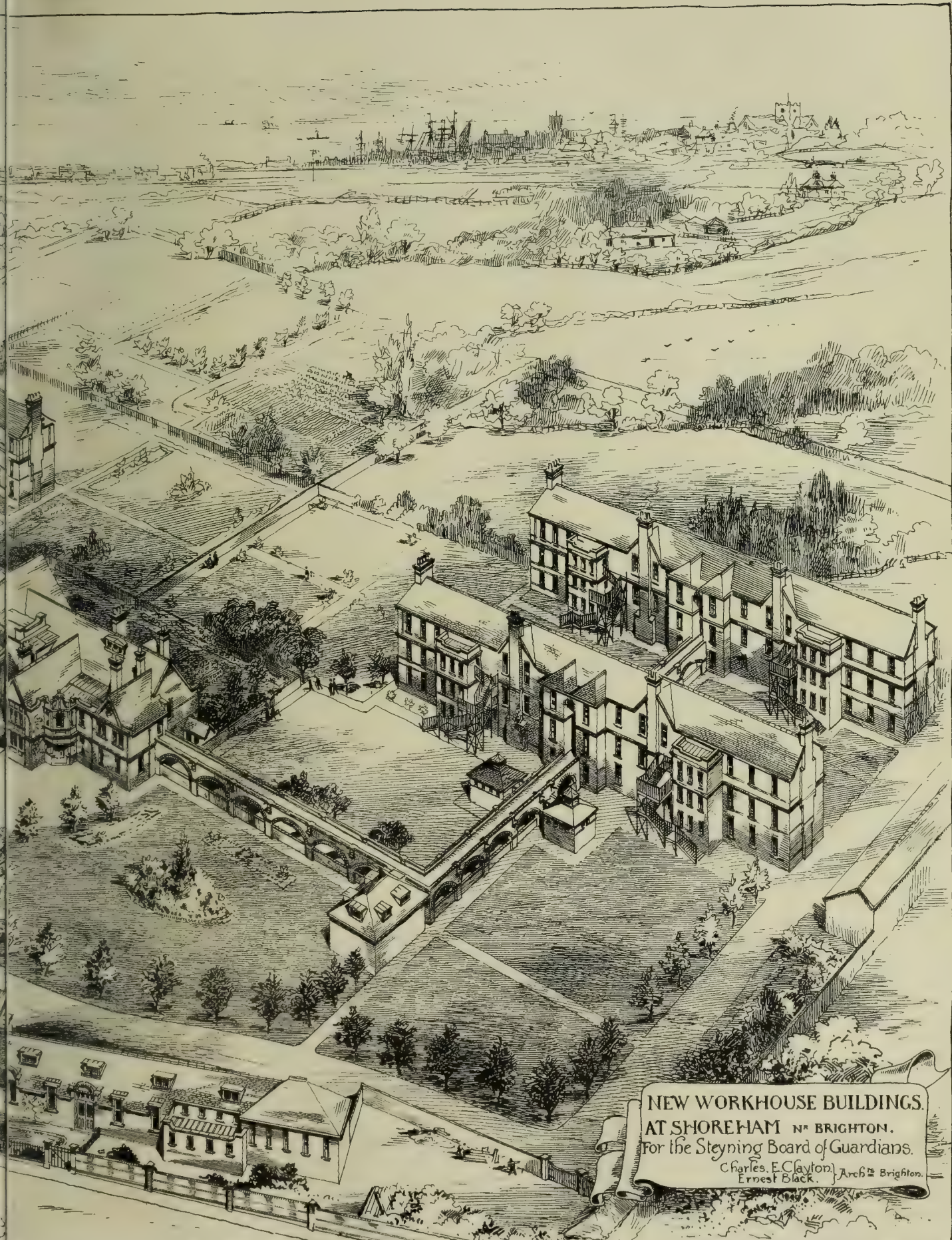

NEW WORKHOUSE BUILDINGS.  
AT SHOREHAM NEAR BRIGHTON.  
For the Steyning Board of Guardians.  
Charles. E. Clayton, Arch<sup>t</sup> Brighton.  
Ernest Black.

Photo-Lithographed & Printed by Messrs. Alderman & Co., Queen's Gardens, W.





"GLENROY" FINCHLEY BY E. W. POLEY ARCHT.

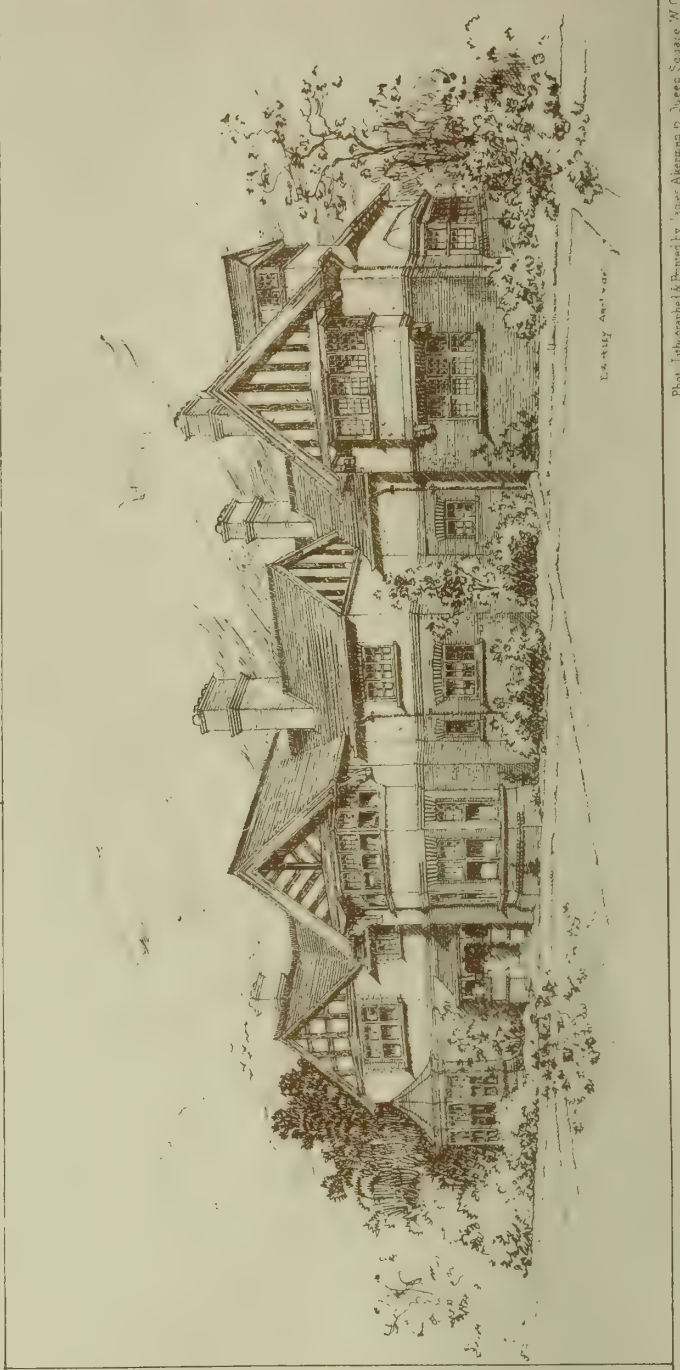
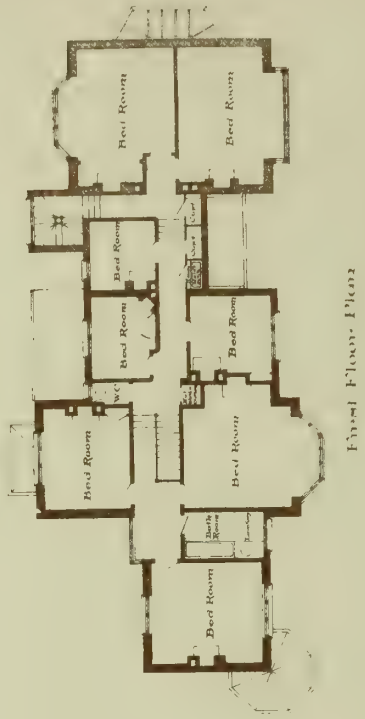











THE BUILDING DEWS, MAY 27, 1898.



FOREST LODGE, TULSE HILL. WIMPERIS & ARBER, ARCHITECTS

PHOTO-TINT BY JAMES AKERMAN, 10, JOHN S. SQUARE, LONDON, W.



### PROFESSIONAL AND TRADE SOCIETIES.

**THE ARCHITECTURAL ASSOCIATION OF IRELAND.**—At the annual meeting held on May 17th, the following were elected as committee and officers for the session 1898-9:—President, J. Howard Pentland, R.H.A.; vice-presidents, Joseph Holloway and George Sheridan; committee (9), H. Allberry, F. Batchelor, T. Coleman, T. E. Hudman, A. I. McGloughlin, L. O'Callaghan, Cecil Orr, R. C. Orpen, and M. J. Tighe; hon. treasurer and registrar, F. G. Hicks, 5, St. Stephen's - green; hon. librarian, Joseph Geoghagan, 22, Clare-street; hon. secretaries, R. M. Butler, Dawson Chambers, Dublin, and A. W. Moore, 183, Great Brunswick-street, Dublin (the above form the committee); hon. auditors, T. F. S'evin and J. W. Boucher.

**BRITISH ASSOCIATION OF WATERWORKS ENGINEERS.**—The third annual general meeting of the British Association of Waterworks Engineers, which lasts over four days, opened at Southampton on Tuesday. There was a large attendance of delegates, and the mayor gave them a cordial welcome. Mr. W. Matthews, the Southampton borough waterworks engineer, took the chair as president-elect for the year and delivered his inaugural address. The company, together with a number of residents, were afterwards entertained by the mayor to lunch on the Royal pier. In reply to the toast of "Success to the Association," the president stated that although only established three years ago, the association numbered over 200 members, who had charge of the water supply to 11½ millions of people, and they had the care and management of works of the value of over £40,000,000. The afternoon was devoted to the reading and discussion of various technical papers. On Wednesday a business meeting was held in the morning; after luncheon the members visited the works of the South Hants Waterworks Company, examining in detail the wells, headings, pumping-station, and softening works on the subsiding system. The annual dinner took place in the evening; and under the presidency of Mr. Matthews yesterday (Thursday), a business meeting was held in the morning, and after lunch a visit was paid to the Southampton waterworks. To-day (Friday) the members will visit the Portsmouth waterworks and Gosport waterworks, and to-morrow will be devoted to excursions to places of interests in the neighbourhood of Southampton.

On Wednesday week the Bishop of Southwell reopened the Church of St. Helen's, Austerfield, after restoration from designs by Mr. C. Hodgson Fowler. Many objects of antiquarian interest have been disclosed during the recent restoration, chiefly a Norman arcade buried in the north wall, which now occupies its original position. A new north aisle has been built by subscriptions from the Society of Mayflower descendants in America, and other descendants of the Pilgrim Fathers, and a memorial brass is shortly to be inserted in this aisle in memory of William Bradford, who was a native of Austerfield.

The new board schools, Portsmouth, are being ventilated by means of Shorland's patent exhaust roof ventilators, the same being supplied by Messrs. E. H. Shorland and Brother, of Manchester.

At Wolverhampton, on Monday, the chairman of the Parks and Baths Committee performed the ceremony of opening St. George's Churchyard, which has been laid out by the corporation as an open space for the people. The work has been taken in hand by the borough surveyor, Mr. J. W. Bradley, and a large number of tombstones have been removed, walks have been made, and the ground has been turfed and planted with trees and shrubs.

A serious accident occurred on Saturday afternoon at the new Warwick Revolving Tower, now being completed at West End, Morecambe. The tower, similar to one opened at Great Yarmouth last season, and another now being constructed at Scarborough, is on a novel principle, a framework of about 15ft. in diameter and 130ft. high being encircled by a large car, said to be capable of holding 200 persons, and revolving on a platform as the latter ascends and descends. The tower was expected to open for Whit-week, and on Saturday, shortly after two o'clock, the cage, occupied by about eight or ten workmen, was hoisted 20ft. with a view to a preliminary trial. As the cage was being lowered, one of the wire ropes snapped. The cage descended rapidly; eight men were injured by the impact, and four had to be conveyed to the Lancaster Infirmary.

### PARLIAMENTARY NOTES.

**THE COLLAPSE OF ABBEY MANSIONS, WESTMINSTER.**—Sir H. Vincent asked the First Commissioner of Works on Tuesday whether the block of buildings at Abbey Mansions, Victoria-street, at which the roof recently fell, was exempt from the provisions of the London Building Act, 1894, by reason of any exemption or privilege attaching to the Crown or to the Commissioners of Works; whether the Commissioners of Works had, through any officer or officers, supervised or prescribed the structural construction or solidity of the building, or whether any responsibility in regard thereto was undertaken by the Commissioners or their officers; whether the County Council had ever brought to the attention of the Commissioners the question of exemption, or inquired whether any exemption was claimed; and whether the Commissioners caused the height of the building to be raised. Mr. Akers-Douglas: I am advised that no exemption whatever from the Building Act and no privilege can attach to the building by reason of any Government exemption or privilege. An agreement was entered into last November, under which, in certain eventualities, the Commissioners of Works might have become lessees of the building when fully completed; but until then they had no present interest in it, and they have never been in occupation. My department has exercised no supervision whatever, nor made any prescription in regard to the matter, and no responsibility in regard to the structural construction or solidity attached to the department, or was undertaken by it. The County Council never brought the matter to the attention of the department, and made no such inquiry. If they had, they would have been informed that no exemption existed, so far as the Crown was affected. The Office of Works did not cause the height of the building to be raised.

### CHIPS.

Alton parish church is about to be restored from plans by Mr. A. Crowley, A.R.I.B.A.

The annual exhibition of the antiquities, &c., found on the site of the Romano-British city at Silchester will be held at Burlington House, Piccadilly, from Wednesday June 1 to June 15 inclusive.

A contract for the construction of the new Bute Dock at Cardiff has been let to Messrs. Topham, Jones, and Raitton, of Great George-street, Westminster. The work will be executed at schedule prices, and the total outlay is estimated at £550,000. The contract refers to the dock pure and simple, the construction of a pier and the dredging of the channel being the subject of separate tenders.

The picturesque ruins of Birkenhead Priory have been repaired and rendered secure. The work has been carried out for the corporation of Birkenhead by Messrs. W. Haswell and Son, of that town.

A new infirmary, kitchen, and other buildings are being added to the workhouse at Chester-le-Street at a cost of about £11,000. Messrs. Crowe are the architects.

The churchyard cross at St. John's, Cardiff, which was a headless stump, has just been restored from designs by Mr. Charles B. Fowler, F.R.I.B.A., Cardiff, the architect for the restoration of the church itself. The new shaft is of Portland stone, and the head represents the Crucifixion on one side and the Ascension on the other. Mr. W. Clarke, of Llandaff, was the sculptor.

New schools are being erected at Clarence-street, Newport, Mon., and special consideration has been given to the ventilation, which will be carried out on the Boyle system.

The new police-court erected at Castleford at a cost of between £6,000 and £7,000, was opened on Friday by Sir John Austin, Bart., M.P.

At Warrington, on the 19th May, Mr. W. Meade King conducted a Local Government inquiry into an application by the Warrington Corporation for sanction to borrow £31,933 for purposes of street improvement, £10,000 for the purchase of slot and other meters, and £700 for the purchase of a recreation ground.

The surveyor to the Ilford Urban District Council has just submitted his annual report. Plans for about 1,500 houses had been passed in the year, and the total length of new streets for which plans have been passed is nearly 14 miles.

The *Peterborough Advertiser* computes that at the present time there are something like 24 brickyards in the district of Peterborough giving employment to between 1,500 and 2,000 men and boys. Enough bricks are now turned out annually to build a very decent sized town.

An exhibition of the collected works of Mr. Clarence White, P.R.C.A., R.W.S., was opened on Tuesday in the City Art Gallery, Manchester. The subjects of most of the pictures are drawn from North Wales and the Lakeland of the North.

### WATER SUPPLY AND SANITARY MATTERS.

**METROPOLITAN WATER COMMISSION.**—A meeting of the Royal Commission which is inquiring into the question of the water supply of the Metropolis was held on Monday, under the presidency of Viscount Llandaff, at the Westminster Town-hall. Sir Alexander R. Binnie, engineer-in-chief to the London County Council, who was recalled, laid before the commission in tabular form various estimates of the relative cost of obtaining the water necessary for the supply of London from the Thames by means of the Staines reservoir scheme or by gravitation from Wales. The witness estimated at £10,703,570 the cost of obtaining from the Thames by the Staines scheme 114½ million gallons a day, being the difference between the total 300 million gallons of the Staines scheme, if carried out in its entirety, and the 185½ million gallons which the water companies are now authorised to take from the Thames, allowing a *minimum* flow of 250 million gallons over Teddington Weir. With a *minimum* flow of 200 million gallons over Teddington Weir the estimated cost of obtaining the same amount of water would be £10,881,805. On the other hand, the cost of obtaining the 114½ million gallons by the Welsh gravitation scheme was estimated at £10,032,750—namely, £1,850,000 for the Yrton reservoir and head works; £6,867,500 for the construction of an aqueduct 162 miles in length, composed of 117 miles of covered conduit and tunnel, to carry 200 million gallons a day, together with 45 miles of pipe to carry the 114½ million gallons a day; and £1,314,750 for the construction of the terminal works at Elstree, exclusive of filters. The estimate which was given by Mr. Deacon for these works amounted to £9,848,000 only, but this was due to a reduction in the cost of the masonry and tunnel portion of the conduit by reason of a lessening of the daily flow to 133½ gallons, as compared with the 200 million gallons allowed for by Sir Alexander Binnie. Another table which was handed in contained an estimate of the cost of bringing from Wales 147 million gallons a day from the combined sources of the Yrton and the Towy, which however, could not be taken in comparison with the Staines schemes, because the Thames could not be made to yield, at any reasonable cost, 147 million gallons per day in addition to the 185½ million gallons already sanctioned. The total estimated cost of the Yrton and Towy scheme was put at £14,112,000, comprising £2,190,000 for the reservoirs and head works, £7,760,000 for the construction of an aqueduct 162 miles in length, composed of 117 miles of covered conduit and tunnel and 45 miles of pipes, the whole to convey 200 million gallons a day, £1,911,000 for terminal works at Elstree, £1,654,750 for filters, and law and Parliamentary charges £597,250. The witness added that he had come to the conclusion that, whether the water undertakings remained in the hands of the existing companies or were transferred to some public body, that body or the companies would be ultimately driven to go outside the Thames Valley for an additional supply of water. In his view this enforced the necessity for purchase. It was highly desirable that the water supply of London should be not only uniform, but unified. By the Chairman: In addition to the amount paid to the companies for the purchase of their undertakings, the purchasing authority would have immediately to incur the expenditure involved in the carrying out the first instalment of the Welsh scheme, or of continuing the scheme for obtaining the whole 300 million gallons a day from the Thames. In the former case, the total cost would be about £21,500,000, and in the latter case it would be about £18,000,000—£7,336,375, the estimated cost of obtaining the already sanctioned 185½ million gallons from the Thames, being common to both totals. Mr. Pember, Q.C., on behalf of the water companies, subjected Sir Alexander Binnie to a long cross-examination with a view to showing that the Staines reservoir scheme would be just as effective and much more economical than the Welsh gravitation scheme. Asked to state what was proposed to be the average depth of the Welsh reservoir, witness declined to give an answer, on the ground that it might prejudice the London County Council hereafter in their negotiations with the landowners. The commission on rising adjourned until Monday, June 6.

The annual conference of the Scottish Plumbers' Association was concluded in Glasgow on Saturday, when the reports, showing satisfactory increases in membership and finances, were adopted. It was agreed to remove the general office of the Association from Glasgow to Edinburgh.

Colonel Marsh, R.E., one of Her Majesty's Local Government Board inspectors, held an inquiry at the municipal offices on Wednesday week into an application of the Southampton Town Council to borrow £28,428 for purposes of water-supply, including £19,700 for a new 24in. main from the reservoir at Otterbourne. Mr. W. Matthews, C.E., the water engineer, explained the proposals.

## STATUES, MEMORIALS, &amp;c.

**CHICHESTER.**—The monument erected in Chichester Cathedral to the memory of the late Bishop Durnford, who presided over the diocese for a period of 25 years, was unveiled at a special service on Monday afternoon. The ceremony was performed by the Duke of Richmond and Gordon. The monument consists of altar tomb with moulded base and slab of Purbeck marble, upon which rests a recumbent effigy of the late Bishop in full episcopal habit, executed in alabaster. Above this is a richly-carved canopy formed out of a block of Chunch which originally weighed seven tons. Near the Bishop's effigy are statuettes representing St. Wilfred, who introduced Christianity into Sussex, and St. Richard, Bishop of Chichester. The monument, designed by Mr. Thomas Garner of the firm of Messrs. Bodley and Garner, was executed by Messrs. Farmer and Brindley, of Westminster Bridge-road, and has cost about £2,000. It is erected under the eastern arch of the south-east chapel of the nave (St. Clement's Chapel).

## LEGAL INTELLIGENCE.

**HEAVY FAILURE IN THE FURNISHING TRADE.**—An extraordinary general meeting of the shareholders of Messrs. Worsleys (Limited), Manchester, Bradford, and Sheffield, was held at the registered offices of the company, Manchester, on Friday: Mr. Samuel Smith (chairman) presiding. He stated that the assets of the company on paper were something like £56,000, and the liabilities, including £24,600 to trade creditors, were only some £45,000. The company could not continue in business, and he submitted a resolution urging that the company be wound up voluntarily. The resolution was carried. The shareholders appointed four liquidators, with a committee of inspection consisting of five of the principal creditors representing the Birmingham and Kidderminster trades.

## CHIPS.

The town council of Stafford have given a bonus of £250 to Mr. Bell, their gas and electricity manager, for extra services rendered by him in connection with the electric light installation.

The Operative Masons' and Stonecutters' Union, of Aberdeen, have elected Mr. George Younie, of that town, as general secretary, to devote his whole time to the office, in succession to Mr. King, resigned.

At Lambeth police-court, on Saturday, Frederick Clarke, a surveyor of Elm-grove, Peckham, was committed for trial on several charges of obtaining money by false pretences, and also on a charge of bigamy.

To the collection of pictures in the Art Gallery at Oldham two portraits have just been added as gifts—one that of the Hon. E. Lyulph Stanley, formerly M.P. for the borough, the work of Mr. Sefton, and the other that of the late Edmund Hartley, mayor of the borough in 1869-70.

The nave of the parish church of Cornely, which is in a sadly dilapidated state, is about to be restored from plans by Messrs. St. Aubyn and Wadling, of London.

The directors of the New Peterborough Brick Company, Limited, have voted to Mr. F. H. Cooke, on his retirement from the post of secretary and surveyor to the company, a honorarium equivalent to six months' salary, in addition to which the ordinary shareholders have presented him with a cheque for £250 as an acknowledgment of his services to the company. A complimentary dinner was given at the Angel, on Saturday, by Mr. F. H. Cooke, to the office staff of the New Peterborough Brick Company, the foremen at the works, and several friends.

The coroner's court, mortuaries, and shelters for the board of works of the Poplar district are about to be erected from the designs of Messrs. Lansdell and Harrison, selected in open competition some time since.

The guardians of Wandsworth and Clapham Union are about to proceed with the erection of the new nurses' home at their infirmary, St. John's Hill, from the designs of Messrs. Lansdell and Harrison.

At a meeting of the directors of the Dysart and District Building Company, Limited, held on Monday, Messrs. Swanston and Legge, Kirkcaldy, were appointed architects and surveyors to the Company.

Cold Ashton Church, near Bath, has just received into position a four-light window of a very striking character, different in many respects to the treatment usually observed in stained glass. The subject is "The Baptism of Christ in the Wilderness." The window has been designed and executed in the studio of Messrs. Swaine, Bourne, and Son, Birmingham, under the supervision of the architect, Mr. Augustus Frere, Essex-street, Strand, London.

## Our Office Table.

MR. G. F. WATTS, R.A., has placed at the disposal of the Trustees of the National Portrait Gallery, the portrait of Mr. Gladstone painted by him in 1865, which will be placed at once on temporary exhibition in the galleries, and will be on view next Saturday. The trustees have also acquired by purchase the original portrait group, drawn by the late Sir John Gilbert, R.A., of the Earl of Aberdeen's Cabinet, in which Mr. Gladstone held the office of Chancellor of the Exchequer. This group was afterwards engraved with considerable alterations by William Walker, the engraver, and an early proof of the engraving has also been acquired to accompany the drawing. The following portraits have also been presented to the Gallery and accepted by the trustees:—Sir John Bowring, F.R.S., painted in 1826 by John King, presented by Lady Bowring; Robert Carr, Earl of Somerset, K.G., and Robert Cecil, first Earl of Salisbury, K.G., two small companion portraits, attributed to John Hoskins, presented by Sir Henry H. Howorth, M.P., F.R.S.; Sir John Everett Millais, P.R.A., a pen-and-ink sketch, by Charles Keene, presented by Mr. Joseph Pennell; John, first Earl Russell, K.G., a full-length portrait by Sir Francis Grant, P.R.A., presented by the Duke of Bedford; Montagu Bertie, second Earl of Lindsey, painter uncertain, presented by Sir Coutts Lindsay. The following portraits have also been acquired by purchase:—Sir Henry Vane, the elder, possibly by Cornelius Janssen; Queen Catherine Howard, painted in the school of Holbein. Thomas Landseer, A.R.A., the engraver, drawn in chalks by his brother, Charles Landseer, A.R.A.; Thomas Chubb (1679-1747), a noted writer on Deism and other theological questions, a curious portrait painted by G. Beare. Edward Law, first Baron Ellenborough, painted by Samuel Drummond, A.R.A. In the cases of Mr. Gladstone and Sir John Millais, the trustees have had no hesitation in suspending their usual rule as to the expiration of ten years from the date of decease.

A SERIES of five large circular medallions which had been let into the ground-floor wall of an 18th-century house facing Kew-green, has lately been removed, when examination showed that, instead of being mere plaster casts, as had been supposed, the medallions are original bronzes. The house had, for the greater part of this century, been let to private tenants; but it is thought that, in the time of King George III., the abutment containing the medallions was used as a tea-room for the ladies of the Court. The Queen has consented to allow the find to be shown at the present Art Metal-work Exhibition at the Royal Aquarium. Sir J. Charles Robinson describes the medallions, which are 3ft. in diameter, and of gunmetal, as very elaborate compositions in high relief, and of the most finished execution. They are of French origin, dating during the second half of the 17th century, and the subjects are representations, treated in heroic or monumental style, of actual occurrences in the career of King Louis XIV. They probably formed part of some public monument erected in honour of Louis XIV. during his lifetime, perhaps one destroyed during the Revolution. In one of the compositions the King, surrounded by courtiers, is seen present at the erection of an obelisk, the work being presided over by an important personage in ecclesiastical costume. In another the King, seated in his robes of State and crowned, is receiving the homage of a group of personages, apparently lawyers or councillors of State. In two other of the medallions the King is respectively seen entering a city at the head of a regiment of musketeers, and dismissing the captured garrison of the place. The fifth relief represents Louis in his Royal robes, wearing his crown, and with a sceptre in his hand, apparently receiving a deputation of three ambassadors or envoys. In the background is a figure bearing a banner, on which, fortunately, is an elaborate crowned escutcheon of arms with supporters. The bearings are somewhat obscure, but they seem substantially to be those of the kingdom of Sweden. One of the envoys, moreover, is decorated with the Danish Order of the Elephant. Composition incidentally confirms the supposition as to the date of production of the bronzes, inasmuch as the two northern Powers took part in the Peace of Nimeguen in 1679. Sir J. C. Robinson suggests that they, nevertheless, may

have been designs by Coysevox, Girardon, or Pierre Puget, and with equal likelihood the castings were by the brothers Keller.

THE Nottingham Corporation are applying to Parliament for powers which, if granted, may have a far-reaching effect upon English fire insurance companies. The rates, particularly on electric-light buildings, have been very heavy, and in consequence the Brighton Corporation communicated with every municipal body in the kingdom with a view to have formed a Municipal Fire Insurance Union. Nottingham, however, in its Bill applies for leave to establish a fire insurance fund, which, in the event of a fire, shall be available for the purposes of rebuilding and restoring property belonging or on loan to, or in the control of, the corporation. The fund is to be allowed to accumulate to £50,000, out of which sum loss by fire shall be made good, and if by any chance the fund is diminished as a result of claims upon it, the reserve is to be again made up to the sum named.

A DEPUTATION representing the County Councils Association, the National Association for the Promotion of Technical and Secondary Education, and kindred bodies waited upon Mr. T. W. Russell at the Local Government Board on Friday, to ask that the Registration of Plumbers Bill might be so amended as to give the educational, as apart from the practical, side of the question a fair representation on the council, and place the examinations upon a definite and impartial basis. Mr. Russell said the Bill could not pass this year, so there was no immediate hurry. He suggested a conference, and the settlement of points between those interested.

ANY architect or builder who is unfamiliar with the useful little treatise on "The Cause and Cure of Damp and Decay in Masonry," of which the sixth edition is issued by Messrs. N. C. Szerelmy and Co., Rotherhithe New-road, S.E., should send for a copy. Some very useful information is given for the testing of buildings for damp, and with regard to the decay of stone and the corrosion of iron. In all such cases the "stone liquid" and iron paint supplied by Messrs. Szerelmy and Co. will be found an infallible cure. They have stood the test of time, and we have repeatedly advised their use with the most complete success.

## MEETINGS FOR THE ENSUING WEEK.

WEDNESDAY.—Edinburgh Architectural Society, "Grammar of House-Planning," by J. J. Henderson. 8 p.m.

FRIDAY.—Royal Institution, "The Development of the Tomb in Egypt," by W. M. Flinders-Petrie. 9 p.m.

SATURDAY.—Edinburgh Architectural Association, Annual Excursion to Alloa and Clackmannan.

## THE ARCHITECTURAL ASSOCIATION.

JUNE 4th, SUMMER VISIT to Sutton Place, Guildford, by kind permission of Mr. Sidney Harrison. Meet at Waterloo Station (main line) for the 1.50 train to Worplesdon. Name and P.O. for fee to be sent to Mr. G. A. Lansdown, 5 and 7, Warwick-street, Charing Cross, S.W.

E. HOWLEY SIM } Hon. Secs.  
G. B. CARVILL }

There was unveiled on Tuesday in the Scottish Conservative Club, Edinburgh, a life-size marble bust of the Queen, in commemoration of Her Majesty's Diamond Jubilee. It is the work of Mr. Birnie Rhind, A.R.S.A., who has already contributed to the decoration of the clubhouse by his bust of Lord Salisbury. The bust rests on a pedestal designed in the Louis XVI. style, and is of polished white marble, with ormolu enrichments.

Work is so far completed on the trunk line of the Trans-Siberian Railway between China and Tashkent that the rails are now being laid at the rate of nearly three miles per day, and it is possible that the first train will reach Tashkent to-morrow (Saturday).

The new offices of the Law Union and Crown Insurance Company at the corner of Clare and Marsh streets, Bristol, were opened on Monday. They have been built from designs by Mr. Henry Williams, of that city.

The foundation-stone of a new Masonic Hall was laid by Earl Jersey at Chipping Norton on Friday. Mr. A. J. Rowley, of Oxford, is the architect, and Mr. Alfred Groves the builder.

A special meeting of the Sherness Urban District Council was held on Saturday afternoon for the purpose of signing the contract with Messrs. Fasey and Son to erect a new town pier at a cost of £12,200.



LIST OF COMPETITIONS OPEN.

Trowbridge—Technical School (£5,500 limit—Mr. E. W. Mountford, F.R.I.B.A., Assessor) .....	£40 (and 5 per cent. com.), £30, £20	H. Ledbury, Sec., Castle-street, Trowbridge, Wilts.....	May 28
Church Gresley—Alterations to Church .....	£5 5s.	F. G. Mansfield, Secretary, Chesterfield Villa, Church Gresley, Staffs .....	30
Cricklade—Water-Supply Schemes .....	£21, £10 10s.	Harry Bevin, Clerk R.D.C., Union Offices, Wootton Bassett.....	31
Walkend—Laying Out Park .....	£50, £20	W. S. Daglish, Clerk, 28, Sandhill, Newcastle-on-Tyne .....	June 1
Kilkenny—Twenty-six Houses, Hospital-road (£90 each limit), Fifteen Houses, Lake-road (£120 each) .....	No premiums .....	W. K. Clare, Sanitary Officer, U.D.C. Offices, Kilkenny .....	2
Pendlebury—Three Chapels, Offices, Lodge, Entrance Gates, and Boundary Walk, at proposed Cemetery .....	£50 (merged), £30, £20 .....	Samuel Brown, Town Clerk, Town Hall, Salford .....	7
Castletown—Sewerage Works .....	£105 (merged), £52 10s.....	J. Donovan, Sanitary Officer, Board Room, Castletown, Ireland .....	9
East Ham—Public Offices, Library & Technical Institute, Fire-Engine Station, Public Baths, and Offices (cost about £55,000) .....	£25, £10 .....	C. E. Wilson, Clerk U.D.C., Public Offices, East Ham, E.....	24
Bridlington Quay—Orphanage and Convalescent Home, St. John's-avenue (cost about £1,500) .....	£100, £50, £25 .....	George Abbott, Secretary, 222, Solly-street, Sheffield .....	30
Formby—Sewerage of a Portion of the Township .....	£36 15s., £10 10s., £5 5s. ....	J. H. Havelock Sutton, Surveyor, Piercefield-road, Formby.....	July 1
Appleton—Laying Out Park and Recreation Ground .....	£100, £50, £25 .....	John S. Sinclair, A.M.I.C.E., Town Hall, Widnes .....	1
Warrington—Police Station, Court House, &c. ....	£210 (merged), £156 10s., £105 .....	J. Lyon Whittle, Clerk, Town Hall, Warrington .....	2
Glasgow—Exhibition Buildings (£60,000 limit) .....	£656, £438, £219 .....	H. A. Hedley, Secretary, 141, Buchanan-street, Glasgow .....	Aug. 15
Stockholm—City Railway Stations and Junctions .....	5 per cent. commission; £10, £5.....	Consulate General, 27, Great Winchester-street, E.C. ....	31
Pitlochry—Public Hall .....		W. Scott Pennell, Solicitor, Pitlochry, N.B. ....	—
Motherwell—Young Men's Institute .....		Secretary, Y.M. Institute, Motherwell, N.B. ....	—

LIST OF TENDERS OPEN.

BUILDINGS.

Surbiton—District Council Offices .....	Urban District Council .....	Forsyth and Maule, Architects, 16, Great Marlborough-street, W....	May 28
Dundee—Victoria Hospital .....	Trustees .....	J. Murray Robertson, Architect, 33, Albert-square, Dundee.....	28
Cardiff—Riverside Conservative Club, Neville-street .....	Guardians .....	Veall and Sant, Architects, 5, Arcade Chambers, High-st., Cardiff .....	28
Talkin—Reading-Room .....	Ind, Coope, and Co. ....	H. Scorer, Naworth Estate Office, Brampton .....	28
Peterborough—Re-letting Workhouse .....	Joseph Hobbs .....	J. G. Stallebrass, Architect, North-street, Peterborough .....	28
Macduff—Free Church .....	United Gaslight Company .....	Matthews & Mackenzie, Architects, 1, Bon Accord-street, Aberdeen .....	28
Hunslet—Alterations to Papermakers' Arms .....	Guardians of St. George-in-the-East .....	Wm. N. Wynn, 10, Livingstone-street, Roundhay-road, Leeds .....	28
Leeds—Alterations to Church Institute .....		George W. Atkinson, Architect, 1, Mark-lane, Leeds .....	28
Snelmore—House at Snelmore Farm .....		Walter H. Bell, Architect, The Market-place, Newbury.....	28
Alnwick—Repairs to Bog Mill Homestead .....		W. R. Hindmart, jun., Alnwick .....	28
Sheffield—Wooden Tower and Tanks, Grimsthorpe Station .....		Hanbury Thomas, Manager and Secy., Commercial-street, Sheffield .....	28
Peterborough—Business Premises at Eastfield .....		William Boyer, Architect, Cowgate, Peterborough .....	28
Addlestone—Two Pairs Houses, Crockford Park-road .....		J. Bowen Binns, Estate Office, Addlestone .....	28
London, E.—Alterations at Workhouse, Raine-street .....		J. R. Brown, Clerk, Raine-street, Old Gravel-lane, E.....	28
Lancaster—Cottages for Employés and South Lodge at Royal Albert Asylum .....		Chas. J. Ashworth, Architect, 41, Market-street, Lancaster.....	28
Ash—Additions, Wyke School .....		Rev. H. Wyall, 29, Cargate-avenue, Aldershot .....	28
Leeds—Alterations to Old Railway Inn, Marsh Lane .....		Wm. N. Wynn, 10, Livingstone-street, Roundhay-road, Leeds .....	28
Fort Augustus—Four Houses .....		Thos. Munro, Architect, 39, Union-street, Inverness .....	28
Lightcliffe—Additions to South View .....		Raymond Berry, Architect, Cheapside, Halifax .....	28
Pontefract—Two Houses in Hurst's-yard .....		William Hurst, Architect, Cora Market, Pontefract .....	28
Elgin—Additions on Property in Maids-place .....		James Jamieson, Architect, Elgin .....	28
Knottingley—Additions to School Board Offices .....		Tennant and Bagley, Architects, Pontefract .....	28
Halifax—Platforms at Savile Park .....		Edward R. S. Escott, C.E., Borough Engineer, Town Hall, Halifax .....	28
Sheffield—Six Villas in Psalter-lane .....		Flockton, Gibbs, & Flockton, Archts., 15, St. James's-row, Sheffield.....	28
Wallsend—Office Extensions .....		Frank Caws, F.R.I.B.A., 22, Fawcett-street, Sunderland .....	28
Dudley—Primitive Methodist Church and Vestries .....		T. E. Davidson, Architect, 33, Grainger-street West, Newcastle-on-T.....	28
Leeds—Seven Houses and Shops, Kirkstall-road, and Six Houses, Greenhow View .....		Thomas Winn, Architect, 92, Albion-street, Leeds .....	30
Elgin—Villa, Mayne-road .....		Reid and Wittet, Architects, Elgin .....	30
Bedlington—Steam Bakery .....		Co-operative Society .....	30
Eastbourne—Terris Memorial Lifeboat House .....		Royal National Lifeboat Institution .....	30
Banbridge—Additions, Goods Warehouse .....		T. Skinner, Local Hon. Secretary, 122, Terminus-road, Eastbourne.....	30
Newark—Additions, Infirmary & Vagrant Wards, Bowbridge-rd. ....		T. Morrison, Secretary, Amiens-street Terminus, Dublin .....	30
Addingham—Church Restoration .....		Sheppard and Harrison, Architect, Kirkgate, Newark .....	30
Edinburgh—Public Baths, Glenogle-road .....		Geo. Dale, F.R.I.B.A., Carlisle .....	30
Burnley—Alterations, Fire-Engine Station .....		R. Morham, City Supt. of Works, City Chambers, Edinburgh.....	30
Dartmouth—Works at Cemetery .....		Borough Surveyor, Burnley .....	30
Londonderry—Additions to Premises, Strand .....		T. O. Veale, Surveyor, Dartmouth .....	30
Aghalee—Reseating Church and New Chancel .....		E. J. Toye, Architect, Strand, Derry .....	30
Keighley—Hospital .....		Rev. J. W. Sleator, Aghalee Glebe, Lurgan .....	30
Aughnacloy—House .....		W. and J. B. Bailey, Architects, 1, Scott-street, Keighley .....	30
Carrickfergus—Lifeboat Shed and Steel Launching Slipway .....		J. J. Phillips and Son, Architects, 61, Royal-avenue, Belfast .....	30
Rochford—Bathroom at Workhouse .....		James C. Holden, Hon. Local Secretary, Carrickfergus .....	30
Dufftown—Villa, Albert-place .....		Frederic Gregson, Clerk, Alexandra-street, Southend .....	30
Pymore—Mills .....		Wm. Watt, Five-street, Dufftown .....	31
Aberfan—Semi-detached Villas .....		F. Cooper, Architect, East-street, Bridport .....	31
Bedford—Underground Sub-Station .....		Wm. Dowdeswell, Architect, Treharris, Mon. ....	31
Hessay—Mission Church .....		T. S. Porter, Town Clerk, Bedford .....	31
Chester-le-Street—Eight Cottages, Daisy Hill .....		C. Hodgson Fowler, F.S.A., Architect, Durham .....	31
Dudley Hill—Weaving Shed .....		Secretary, Central Stores, Chester-le-Street .....	31
Barnsley—Smallpox Hospital, Land-lane .....		T. Leadley, Architect, 3, Coleridge-place, Bradford .....	31
Warrington—Green-House at Cemetery .....		J. H. Taylor, Borough Surveyor, Barnsley .....	31
Baslow—House .....		Thomas Longdin, Borough Surveyor, Town Hall, Warrington .....	31
Anfield Plain—Rebuilding House and Shop .....		E. M. Longson, Architect, Bakewell .....	31
Dalston Hall—Additions .....		D. M. Spence, Architect, Anfield Plain .....	31
Byer's Green—House and Shop .....		J. W. Benwell, Architect, 33, Lowther-street, Carlisle .....	31
Alverstoke—Enlargement of Board-Room at Workhouse .....		T. Swinburn, Front-street, Byer's Green, Spennymoor .....	31
Falmouth—Stalls at Market House .....		H. F. A. Smith, Architect, Star Chambers, Gosport .....	June 1
Blyth—Co-operative Business Premises, York-street .....		Borough Surveyor's Office, Falmouth .....	1
Paisley—Additions to Gasworks, Blackstoun-road .....		A. A. Windle, Architect, 10, Waterloo-road, Blyth .....	1
Bradford—Detached House, Lister Avenue .....		Young and Martin, Town Clerks, Paisley .....	1
Cabragh—Twelve Labourer's Cottages .....		Joseph Cowgill, Architect, Albany Buildings, Bradford .....	1
Londonderry—Two Houses at May-street .....		D. Morris, Clerk of Works, 34, Cabra-parade, Dublin .....	1
Aberavon—Enlargement, Parish Church .....		T. Johnston, Architect, 11, East Wall, Londonderry .....	1
Newport—Eighty Villas .....		G. E. Halliday, F.R.I.B.A., 14, High-street, Cardiff .....	1
Huddersfield—House, Corporation-street .....		Arthur M. Leon, Archt., Central Chambers, 16, Working-st., Cardiff .....	1
Ripponden—Conservative Club .....		K. F. Campbell, Borough Surveyor, Town Hall, Huddersfield .....	1
Benglo—Alterations Warren Park Villas .....		Chas. F. L. Horsfall and Son, Archts., Lord-st. Chambers, Halifax .....	1
Cookstown—Church Schools .....		Jas. Farley, Architect, Old Cross, Hertford .....	1
Newcastle (Ireland)—House, Stable, and Lodges .....		Rev. R. S. G. Hamilton, M.A., Cookstown, Ireland .....	1
Cork—Enlargement of Vicarstown National Schools .....		J. J. Phillips and Son, Architects, 61, Royal-avenue, Belfast .....	1
Alnwick—House and Stabling .....		S. F. Hynes, F.R.I.B.A., 41, South Mall, Cork .....	1
King Cross—Foundry, Fenton-road .....		Geo. Seavell, jun., Architect, Alnwick .....	1
Bryncoch—Master's Residence and Two Cottages at Cottage Homes .....		T. Lister Patchett, Architect, George Square, Halifax .....	1
Bacup—Premises, Market-street .....		Guardians of Neath Union .....	2
Keighley—Twelve Houses, Lawkholme-lane .....		D. M. Davies, M.S.A., 58, Water-street, Neath .....	2
Waddington—Church Restoration .....		J. R. Taylor, Barnley-road, Bacup .....	2
Aber—Sixteen Houses .....		W. H. Hopkinson, Borough Engineer, Keighley .....	2
Carnarvon—Calvinistic Methodist Chapel .....		Austin and Paley, Architects, Castle Hill, Lancaster .....	2
Sligo—Sheds .....		Griffiths and Jones, M.M.S.A., Tonypany .....	2
Garforth—Farm Buildings at Manor Farm .....		R. Lloyd Jones, Architect, 14, Market-street, Carnarvon .....	2
Holyhead—Five Houses, Bryngoleu Estate .....		Thomas J. Mercer, Secretary, Harbour Office, Sligo .....	2
Renfrew—Gasholder Tank .....		Joseph Shepherdson, Architect, 14, Middle-street South, Driffield .....	2
Auchtertool—Malt Barns and Kilns .....		C. Smith, George Hotel, Holyhead .....	2
Nelson—Eight Houses and Four Shops, Bankhouse-road .....		J. M. Laren, Town Chamberlain, Renfrew .....	3
Dewsbury—Three Houses, Northfield Estate .....		C. C. Doig, Architect, Elgin .....	3
Kendal—Shop, Highgate .....		Harry Whitaker, Architect, 21, Market-street, Nelson .....	3
Esker—Four Labourer's Cottages .....		J. Kirk and Sons, Architects, Dewsbury .....	3
		Stephen Shaw, F.R.I.B.A., Kendal .....	3
		L. A. M'Donnell, Architect, 33, Kildare-street, Dublin .....	3

BUILDINGS—continued.

Liskeard—Workhouse Infirmary	John Sansom, Architect, Kiskeard, Greenbank-lane, Liskeard	June 4
Christchurch, Hants—Covered Way at Workhouse	A. Draitt, Clerk, Christchurch, Hants	4
Blackburn—Basement to Victoria Wing of Infirmary	Simpson & Duckworth, Architects, Richmond Chambers, Blackburn	4
Bath—Sanitary Blocks at Workhouse	J. Mannings, Clerk, 3, North Parade, Bath	4
Hamstead Norris—Additions to National Schools	James H. Money, Architect, The Broadway, Newbury	4
Amble—Medd Memorial Schools	Rev. Jas. Fairbrother, The Rectory, Amble	4
Rotherham—Gasworks Buildings	H. H. Hickmott, Town Clerk, Council Hall Rotherham	6
Hitchin—Alterations to Laundry at Three Counties Asylum	F. C. Butler, Clerk to the Visitors, St. Neot's, Hunts	6
Lancaster—Detached Residence	William S. Shell, M.S.A., Architect, Taylor-street, Consett	6
Porth—Additions to Salem Baptist Chapel	T. Howell, 49, Hannah-street, Porth	6
Highgate—Park-keeper's Lodge, Queen's Wood	F. D. Askey, Clerk, Southwood-lane, Highgate, N	6
Consett—Two Shops and Houses, Middle-street	W. S. Spell, M.S.A., Taylor-street, Consett	6
Selby—Purifier House and Meter House	W. J. Mott, Engineer, Selby	6
Langtharpe—Restoration of Chancel of Church	Stephen W. Williams, F.R.I.B.A., Rhyader, Radnorshire	6
Tamworth—Alterations to Spinning School-lane Schools	R. J. and J. Goodacre, Architects 5, Friar-lane, Leicester	6
Rugby—Additions to the Central Stores, 45, Chapel-street	J. T. Franklin, Architect, 40, Bridge-street, Rugby	6
Leicester—No. 38 Butchers' Stalls, General Market	E. George Mawbey, M.I.C.E., Borough Surveyor, Town Hall, Leicester	6
Bradford—Semi-Detached Villas, Horton Top Bank	S. Spencer, Architect, 344, Great Horton-road, Bradford	7
Cefn—Cottage at Station	G. K. Mills, Secretary, Paddington Station, London	7
Weston-super-Mare—New Post Office	Hon. R. ginald B. Brett, Secretary, 12, Whitehall-place, S.W.	7
Gwennap—Cattle House, Piggery, and Stable, with Barn over, at Treboast	C. James, Comford, Gwennap	8
Wareham—Workhouse Bath-rooms, Lavatories, &c.	F. Filiter, Clerk, Union Office, Wareham	8
Blairgowrie—Alterations, Wester Essendy Farmstead	John Panton, Royal Bank, Blairgowrie, N.B.	8
Halifax—Warehouse and 40 yards Chimney, Raglan-street	Chas. F. L. Horsfall & Sons, Architects, Lord-st. Chambrs., Halifax	8
Bargood—Baptist Chapel	James and Morgan, Architects, Cardiff	8
Watford—Electric Light Station	Gordon, Lowther, and Gunton, Finsbury House, Blomfield-st., E.C.	8
Caton—Two Semi-Detached Houses	N. G. Lewis, Architect, 1, New-road, Lancaster	8
Hatfield—Mortuary	Jas. B. Dunham, Clerk, Hatfield	8
Old Aberdeen—Public School	J. A. Ogg Allan, Architect, 31, King-street, Aberdeen	9
Eccleshill—Residence	Kendall and Bakes, Architects, Victoria-square, Leeds	9
Sheffield—Electric Power Station, Kelham Island	Char' E. F. Wike, C.E., City Surveyor, Town Hall, Sheffield	13
Manchester—Extension of Ragged School & Home, Charter-st.	Maxwell and Tuke, Architects, 41, Corporation-street, Manchester	18
Warrington—Foundations & Substructure of Lunatic Asylum	Borough Engineer's Office, Town Hall, Croxdon	22
Stockport—Laundry, &c., and New Wing to Infirmary	Woodhouse and Willoughby, Archts., 10, King-street, Manchester	23
Flookburgh—Three Cottages	W. R. Nash, Cark	25
Horton, near Epsom—Superstructure of Lunatic Asylum (for 2,000 Patients and Staff)	G. T. Hine, Architect, 35, Parliament-street, S.W.	27
Workington—Additions to Board Room	F. W. Jackson, Secretary, Workington	29
Guayaquil—Custom House	Chief Ecuadorian Consulate, Liverpool	Aug. 31
Belem—Cattle Pens, Abattoir, and Two Markets	The Brazilian Legation, London	Oct. 24
Guiseley—Eight Through Houses and Shop	F. Moore, Architect, 40, Sunbridge-road, Bradford	
Carlisle—House, Howard-Place	H. Higginson, M.S.A., 3, Lonsdale-street, Carlisle	
Newport—St. John's Church	F. R. Kempson, F.R.I.B.A., 16, High-street, Cardiff	
Cardiff—New Buildings, Station-terrace	J. P. Jones, Richards, and Budgen, Archts., 18, St. Mary-st., Cardiff	
Ovenden—Two Houses, Jubilee-street	Medley Hall, Architect, 29, Northgate, Halifax	
Burnley—Rebuilding the Bricklayer's Arms, Turf Moor	Thos. Bell, Architect, 14, Grimshaw-street, Burnley	
Bradford—Two Through Houses, Kensington-street	F. Moore, Architect, 40, Sunbridge-road, Bradford	
Higham Ferrers—Two Houses	H. Adnitt, Architect and Surveyor, High-street, Rushden	
Kirkandrews-on-Eden—Farmhouse	Jos. Graham, Architect, Bank Chambers, Bank-street, Carlisle	
Leeds—Laundry Buildings, Kirkstall-road	Johnstone Bros., Architects, 59, Lowther-street, Carlisle	
Glenlyon—Alterations and Repairs to House, Culdaremore Farm	Mackenzie, Innes, and Logan, 23, Queen-street, Edinburgh	
Crawcrook—Thirteen Houses	Wm. Dixon, Architect, St. John-street, Newcastle	
Kirkstall—Chimney, Abbey Mills	C. E. Arundel, Kirkstall Estate Offices, 24, Albion-street, Leeds	
Haworth—Lees Board School	Peterson and Lawson, Architects, 1, Bank-street, Bradford	
Cardiff—Re-erecting 15, High-street	S. Rooney, Quay-street, Cardiff	
Amble—Medd Memorial Schools	J. Wightman Douglas, The Willows, Alnwick	
Skinningrove—Stores	Arthur F. Newsome, M.S.A., Architect, Middlesbrough	
Belfast—Offices, Ann-street	W. J. Moore, Architect, Whitehall Buildings, Ann-street, Belfast	
Pontymister—House	C. Telford, Architect, 3, Queen-street, Cardiff	
Heyrod—Conservative Club	George Rowbottom, Architect, Dean-street, Stalybridge	
Newhey—Store	Butterworth and Duncan, Architects, 4, South Parade, Rochdale	
Lowestoft—Alterations and Additions to the Town Hall	Geo. Hamby, Borough Surveyor, Town Hall, Lowestoft	
Belfast—Rebuilding Licensed Premises, Stanhope-street	W. J. Moore, Architect, Whitehall Buildings, Ann-street, Belfast	
Crossgates—Two Semi-Detached Houses	Percy Robinson, Architect, 72, Albion-street, Leeds	
King's Lynn—Shop and Business Premises, High-street	Louis F. Eagleton, Architect, Bank Chambers, King's Lynn	
Loftus—Alterations to Business Premises	J. F. Cooke, Printer, Station-road, Loftus	
Cork—Houses and Shops in King-street	Arthur Hill, Architect, 22, George's-street, Cork	
Hunslet, Leeds—Fourteen Cottages and Five Through Houses	John E. Lerk, Architect, Hunslet	
Stalybridge—House, Wakefield-road	G. Rowbottom, Architect, Dean-street, Stalybridge	
Haddington—Infant School	John Farquharson, Architect, Haddington	
Gullane—House	J. R. and E. E. Pearson, Architects, 21, Castle-street, Edinburgh	
Heswall, Cheshire—Several Houses	C. B. Taylor, Solicitor, 20, Sir Thomas-street, Liverpool	
Manningham—Converting House into Shop, Heaton-road	H. Hardaker, Architect, Ivegate Chambers, New Ivegate, Bradford	
Ulverston—Paper Warehouse at the Furness Paper Mills	Settle and Farmer, Architects, County-square, Ulverston	
Stalybridge—Stores, Shop, and Two Houses	G. Rowbottom, Architect, Dean-street, Stalybridge	
Exeter—Three Houses, St. David's Hill	James Crocker, F.R.I.B.A., Exeter	
Purston—Villa	Garside and Keyworth, Architects, Pontefract	
Norbitch—Fifteen Pairs of Cottages	W. Belcher, 10, Springfield-road, Kingston-on-Thames	
Llandaff—Ten Workmen's Houses	Jenkin Williams, Architect, High-street, Cardiff	
Belfast—Extension of Licensed Premises, Great George's-street	W. J. Moore, Architect, Whitehall Buildings, Ann-street, Belfast	
Keighley—Engineer's Workshop, Parker-street	John Judson and Moore, Architects, York Chambers, Keighley	
Hunslet—Fourteen Cottages and Five Through-Houses	J. E. Leak, Architect, Hunslet	
Grange-over-Sands—Shop and Dwelling-House, Main-street	John Hutton, M.S.T., Architect, Kendal	
Headingley—Houses and Shop, Highbury-lane	D. Dodgson, Architect, 86, Albion-street, Leeds	
Leeds—House at Roundhay	Percy Robinson, Architect, 72, Albion-street, Leeds	
Macclesfield—Steam Laundry in Brough-street West	A. C. Proctor, Solicitor, 23, King Edward-street, Macclesfield	
Roundhay—Two Shops	John E. Preston, Architect, 32, Northbrook-street, Chapel-Allerton	
Houghton—Six Houses and Shop	R. Heppenstall, Great Houghton	
Purston—Villa	Garside and Keyworth, Architects, Pontefract	
Mansfield—Twelve Houses, Bentinck-street	W. H. Higginbottom, Architect, King John's Chambrs, Nottingham	
Hogonaston—Primitive Methodist Chapel	Hy. Harper, Architect, Market-place, Nottingham	
Haltwhistle—Two Shops and Dwelling-Houses	H. Higginson, M.S.A., Carlisle	
Headingley—Eight Scullery Houses	A. E. Braithwaite, Architect, 26, Norwood-place, Headingley	
Belfast—Nine Houses and Two Shops, Downing-street	Alexander and Reid, 105, Royal Avenue, Belfast	
Barry—Additions, Porthkerry House	Jones, Richards, and Budgen, Architects, Cardiff	
Carlisle—Additions to Drill Hall	G. Dale Oliver, F.R.I.B.A., Carlisle	
Bristol—Factory, Lewin's Mead	F. Shove, Architect, 8, Colston Avenue, Bristol	
Chesterfield—Portland Hotel, West Bars	J. R. Wigfal, Architect, 14, Parade Chambers, Sheffield	
Belfast—Enlarging Licensed Premises, Broadbent-street	T. V. Brennan, Architect, 21, Waring-street, Belfast	
Woodlands Park—Board School (1,500 children)	G. E. T. Laurence, Architect, 181, Queen Victoria-street, E.C.	
East Harling—Three Cottages and Small Farmhouse	Arthur Gayford, Estate Agent, East Harling, Norfolk	
Southtown—Stables	Dudley Arnett, M.S.A., Gorleston-on-Sea	
Amalong—Adding Tower to Church	H. Seaver, Architect, 128, Royal Avenue, Belfast	
Wood Green, N.—Alexandra Schools (1,000 children)	G. E. T. Laurence, Architect, 181, Queen Victoria-street, E.C.	

ENGINEERING.

Cowes—Deep-Well Pumping Machinery	Urban District Council	H. C. Damant, Clerk, High-street, Cowes	May 28
Sandbach—Brick Depositing Tanks	Urban District Council	A. E. Stringer, Clerk, Sandbach	28
Cirencester—Well-Sinking at Coates	Rural District Council	H. L. Cooke, Clerk, Corn Hall Chambers, Cirencester	28
Sherborne—Waterwheel, Gas-Engine, and Gearing	Urban District Council	James Douglas, Clerk, Sherborne	28
Widdin—Port on the Danube (estimated cost, 554,000 francs)	Hertford Rural District Council	Public Works at Sophia, Bulgaria	31
Bayford—Turbine and Pumps	Hertford Rural District Council	T. J. Sworder, Clerk, Council Offices, Hertford	June 1
Bayford—Weir across River Lea	Urban District Council	T. J. Sworder, Clerk, Council Offices, Hertford	1
Ware—Three-Throw Pump at Waterworks	Rhondda Rural District Council	Geo. H. Gisby, Clerk, Town Hall, Ware	3
Pentre—Regenerator Furnaces, &c.	Urban District Council	Walter H. Morgan, Clerk, Council Offices, Pentre, R.S.O., Glam.	3
Haworth—Double-lift Gasholder	Corporation	Wm. Robertshaw, Clerk, Burlington Chambers, Keighley	4
Pontefract—Covered Reservoirs on Park Hill and at Roall	Eastbourne Gas Company	J. W. Sangster, Town Clerk, Town Hall, Pontefract	4
Eastbourne—Gasholder Tank (160ft. by 30ft.)	Urban District Council	J. H. Campion Coles, Secretary, Eastbourne	4
Leyland—Filtration Works and Sewer Extensions	Corporation	John Wesley, Clerk, Leyland, near Preston	4
Pontefract—Pumping Machinery	River Wear Commissioners	J. W. Sangster, Town Clerk, Town Hall, Pontefract	4
Sunderland—Lattice Girders (330 tons), Rolled Girders (100 tons), Cast-Iron Columns (300 tons)	Harbour Commissioners	H. Wake, C.E., Engineer's Office, Commissioners' Quay, Sunderland	6
Belfast—Timber Jetty	Newington Vestry	W. A. Carrie, Secretary, Harbour Office, Belfast	6
Walworth—Electric-Lighting Plant, Penrose-street Station		L. J. Dunham, Clerk, Vestry Hall, Walworth-road, S.E.	6

# THE BUILDING NEWS

## AND ENGINEERING JOURNAL.

VOL. LXXIV.—No. 2265.

FRIDAY, JUNE 3, 1898.

### NEGLIGENCE IN BUILDING.

THE amount of attention that a professional man is expected to bestow upon his work, whether it be as a lawyer, a medical man, or an architect, is, after all, more or less, relative to circumstances. It would be absurd to say, for example, that a reasonable degree of care and skill is to be measured by the number of visits a professional man pays to his patient or his building. The more important, as in the case of a building, the work is, the less is the amount of personal supervision which he often gives. The circumstances are different: in all probability a responsible contractor is employed, there is a competent clerk of works engaged, so that an architect who pays a fortnightly or even monthly visit to his building may be considered to have fulfilled his obligations to his client, and to have exercised a reasonable degree of care; while in less favourable circumstances, where the low tender of an irresponsible builder is accepted and no clerk of works is appointed, the architect would be held negligent if he paid his visits with less frequency than a week. Has it not also something to do with the position of the architect? If he has attained a leading position in the profession, it would be held quite unnecessary, if not *infra dig.*, for him to visit a building frequently—his services and time are far too precious for that; nor would even a legal tribunal consider it negligence on the part of such a man if certain defects were discovered, such as bad bricks, rotten timber, or faulty drain-laying. The convenient and elastic phrase of the Courts, a "fair and reasonable" degree of care and skill would assume a rather different meaning if applied to a man of this eminence than it would to an ordinary practitioner. And we do not find fault so much with this modification, if the construction to be put on such words be applied with discretion as to the kind of work. As we have always contended, it is absurd to expect any architect to personally superintend such details as that of the bond of brickwork, the quality of mortar, whether grouting is properly done every course, or good bricks are put in the backing of walls, or that all timber is of the right sort and quality; and it is far less reasonable to expect a busy architect to do so than a country practitioner. But in matters of design or plan, of the supply of working details for certain parts of a building, the obligations of the architect are of a more precise and absolute character. If by any defect or omission in the plan failure or serious inconvenience arises, we think the architect can be held responsible. A "reasonable and competent degree of skill" would certainly be expected in the plan and construction of a building, and would be held to be as obligatory on the most eminent or busy member as on the poorest practitioner who exercised his art and calling. Business or engagements or value of time could not be pleaded as a set-off to a dereliction of duty on this ground of design, as it applies more to art and skill than a mere mechanical duty, such as that of superintendence. How far-reaching really this responsibility is will be clear to every architect. It extends not merely to plan, but to all details of construction, such as the thickness and solidity of walls, piers, columns, the design of iron girders and columns. If it can be proved that the failure of a wall or pier or girder is due to want of thickness or sectional

area, and, further, that the contractor has faithfully carried out the instructions or plan, no amount of carelessness in the execution of the work will excuse the designer from his share of blame. If he pleads that soft or bad bricks and workmanship, bad casting, or want of testing, is the real cause, and such defect may have added the one straw to the load that breaks the camel's back, it cannot be set off as an excuse to the want of judgement or skill on his part. His structure at least should be sufficiently strong and stable so that it should come well within the margin of safety to be allowed. Of course, there are sometimes delicate limits. An iron girder, for instance, may be so nicely calculated in its area of section within the limits of the formula, that it would safely carry a certain imposed weight if there was no flaw or defect in the iron or the casting. The girder collapses, and it is found, on examination, that the casting was full of air-holes, or fractured in a certain part. It would seem hard to accuse the architect of the failure. In this instance the want of proper testing has led to the disaster. Or in another case which occurred lately in New York, we believe, the fall of a large many-storied building was traced to a defective fixing of iron columns. No doubt the architect could be held responsible for want of care in the superintendence of the details. The verdict in a recent catastrophe in Ontario, whereby a number of people lost their lives by the fall of a floor, exculpated the architect from blame, because the beam, composed of three or more pieces of timber, had not been securely bolted together. The sad and fatal catastrophe at Westminster brings to our mind another instance. The collapse, as reported in our last issue, was alleged to be due to a faulty pier, for which the architect has been held responsible by the coroner's jury. In this case the evidence seems to point to an extraordinary amount of carelessness on somebody's part in the supervision of the building, to the want of a clerk of works, and to a remarkable exhibition of indifference to dangerous conditions on the part of those engaged. That the pier which gave way was carried up higher than the Building Act allowed there appears little doubt. The pier was built, it is said, properly; but the astonishing thing is how such buildings can be erected in London without any control. The state of the law is such, we are told, that there is no control over certain structures like piers and girders. We commend to our readers the report of the expert evidence of Mr. Thomas Blashill, F.R.I.B.A., and that of the district surveyor. But the question of negligence stands quite independent of Building Acts and such legislation, and it is time the profession began to formulate for themselves some principle of guidance. They cannot trust in these matters to chance, or to good luck, of building and workmen, and we fear there is often a great deal taken on trust without any foundation of fact.

### MODEL SPECIFICATIONS.—XV.

MASON.

WE now give a few clauses for stonework of a more finished character, such as quoins, sills, window dressings, cornices, and moulded work. Of course, the requirements will vary; but there are certain essentials that ought to be borne in mind. And we may here note a few points. The architect who wishes his design to be carried into execution with integrity, cannot expect the contractor to do so if he has only the small scale elevations and a short specification to go by. Nor will the scant description in the bill of quantities "including all labours," &c., suffice. A detail ought to be supplied, showing precisely what kind of "labours"

have to be taken. For example, let us take such an item as quoins: unless the elevations are to a large working scale or a detail is given, how is it possible to distinguish an ordinary bevelled or "chamfered" joint from a moulded one? or how can one expect a satisfactory result? Not only is it necessary to describe the length of alternate blocks and their height and thickness, but to show the kind of edges they are to have. We give Fig. 1, four examples of plain, bevelled, and moulded edges, and the kind of hammer-dressed or rock surface required. These quoins may be simply raised blocks, with channels between as at *a*, which represents a pier, or blocks with bevelled edges, hammer-dressed, or vermiculated on face, or moulded as at *c*. Sometimes the angle of wall face is solid and continuous, and the blocks are merely raised as shown at *d*, which may be considered preferable, though not so bold as in *b* or *c* (see plan of angle). The joints of the blocks are better made in a line, with the upper projection as we show in our sketches, the channel being sunk below it, as this plan protects the joint. With the simple bevelled edge the joint can be made in the centre between the two bevels.

Several kinds of tooled work for quoins are used. The punched "rock" face with tooled margin, is bold and effective, a number of cavities is produced by the punch, as shown in Fig. *b*. A "broached" face, Fig. *c*, is produced with a "point," and forms a series of straight furrows and rough ridges in a diagonal direction between chiselled margins. The "rusticated" face and tooled margin is a more frequent mode of finishing quoin stones (see Fig. *d*); it is worked by small chisels and points, and  $\frac{1}{2}$  in. deep irregular cavities are formed, leaving a plain, narrow margin on the face. The "vermiculated" face *d* is cut with small chisels into cavities having a worm-eaten effect.

In the specification of sills, jambs, and architraves, care must be taken to give the sizes or scantlings of stone if not figured on drawings, to describe if the sill is sunk, weathered, and throated, how much longer it is to be than the opening and jambs, if there are mitred and returned ends, and consoles. Sills are generally seated to receive the jambs; these seatings are moulded to the profile of jamb or mullion of stone or brick, as we show in our sketch 11, p. 697, and a slate or copper dowel is inserted to prevent displacement. Mortises are cut opposite each other in the two beds for the dowel, which is then run in with cement. It is necessary to avoid joints in a window-sill under the opening, and they ought to be properly set in cement mortar.

We show also a few Classical window dressings. The architraves or jambs should be made to course with the ashlar or brick facing. In ashlar fronts the stones of the architraves are often of considerable heights of 3ft. or more, and the number ought to be specified to each jamb, and if bonded into a course of ashlar or walling every two or three courses. The stones ought to be dowelled together with slate or copper. To cover the joint between the facing of wall and architrave the stones are rebated sometimes, and also for the wooden frames. The section of cornice we give shows how the stones may be fixed or tailed into the wall. It is necessary to state the depth of bedding, whether the stones are dowelled or plugged with lead or cramped together, and if with metal or slate cramps run with lead or cement. Sulphur and sand or brimstone is better than lead to fix iron or metal cramps. The projection of cornice should be given, and how it is to be counter-weighted or held down by iron bars (see sketch). These bars should be 2in. or 3in. wide and  $\frac{1}{2}$  in. in thickness, with the ends turned into stone above and the brickwork below. Sometimes bars pass through holes in the stone and

QUOINS AND DRESSINGS

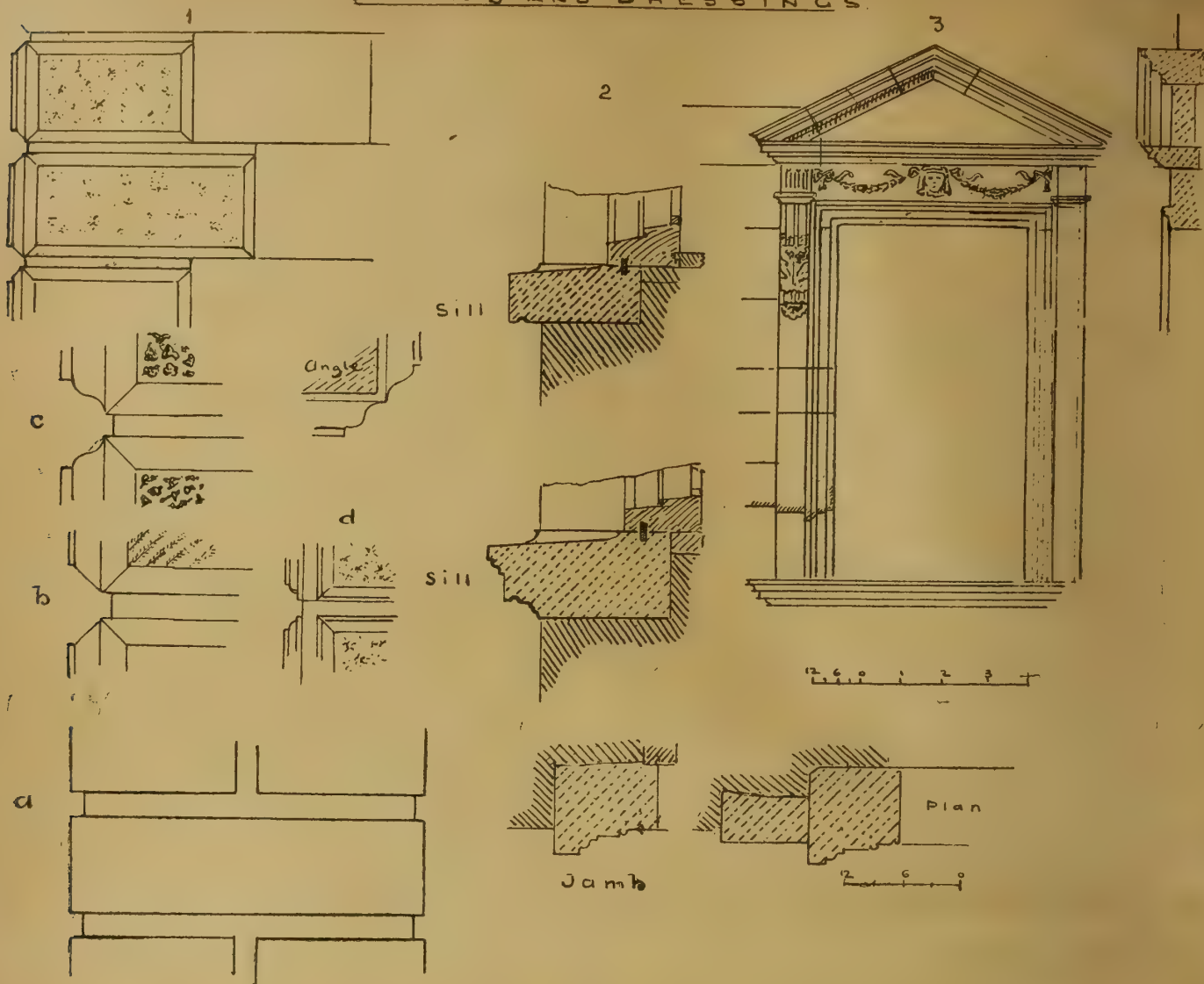

brickwork, and are secured by nuts and plates in the wall, filled up with cement. The distance apart of these hold-down bars should be specified.

21. *Ashlar Facing*.—The ashlar facing to consist as nearly as circumstances will admit, of courses 12in. or 15in. high, formed with headers having a horizontal bed of 1ft. 6in. by 12in., and stretchers having a horizontal bed of 3ft. by 5in., the quoin stones being in no direction less than 1ft. 6in. on their bed. All horizontal joints to have a slight chamfer on the upper edge of each stone.

We have given a clause for quoins, p. 698 (clause 6). Here are one or two more.

22. *Quoins*.—The angle-quoins to be worked as shown in detail, with bevelled (or moulded) edges. The projecting faces to be 1½in. (or 2in.) beyond surface of wall, and to be hammer-dressed (or vermiculated), and the channel or grooves to be sunk below the joint of upper bed. The blocks to be alternately 15in. and 9in. (or 18in. and 12in.) in length, and 9in. or 12in. in height, and bond with the courses of ashlar. Or—

The angle-blocks of main front to be finished with roughly-wrought (or tooled, or punched, or rusticated faces) with chamfered (or moulded channels), and to be of the lengths, heights, and sectional form shown and figured on detailed drawings, two quoins being cut out of one stone, as shown in sketch.

23. *Sills*.—The windows of ground and first floors to have rubbed Portland stone sills 9in. by 6in. (or 9in. by 4in.) sunk, weathered, and throated with fair ends grooved for iron tongues. Or—

Put Portland stone window sills 14in. by 4in. to the windows. All the sills to be 4in. longer than the width of opening, and grooved for metal tongues, and to be in one length. The sills and projecting stonework to be cased during the progress of work, and cleaned off at completion. Or—

Put to all windows 9in. by 3in. rubbed, sunk, weathered, and throated Yorkshire sills 4in.

longer than openings, with stopped ends grooved for iron tongues, and with stools worked on for mullions and reveals.

24. *Moulded Sills*.—To put to windows of principal rooms finely-wrought and rubbed Portland stone sills 12in. (or 14in.) wide by 6in. thick (or moulded as shown), sunk, weathered, and throated and tongued. The sills to be 4in. (or 6in.) longer than the width of opening (and jambs). Moulded trusses to be placed under jambs.

25. *Jambs*.—The doorways (or window openings) to have architrave jambs of solid Portland or other stone, moulded, of scantling shown in sketch. The jambs to be in two (three, or more) stones, and to be properly set and dowelled to stone sill (or plinth). The jamb to be rebated on its outer side. Proper bond to be obtained by varying the depth of stones. The lintel to be of one stone. Or—

Put to the doorway architrave jambs 9in. by 6in. (or as drawing); the jambs to be in three (or more) stones, dowelled together with copper (or slate) dowels, and bonded into wall. The stones to extend from face of wall to face of frame and the back of frame alternately. The outer mouldings of architrave to be rebated 1in. over wall face. The entablature to be of two or three pieces in depth, as shown on detail; the frieze to be not less than 6in. on bed, and the cornice above of the scantling shown in section, or 9in. or 12in. projection, tailed into wall 9in. or 12in., moulded as shown, and jointed in three pieces, with mitred returns, &c.

26. *Window Dressings* (see sketch 3).—The windows of — to have moulded sill, architrave, and pediment, as shown of the several scantlings and projections shown in detail. The window-sills to be finely rubbed, moulded as shown, and sunk, weathered, and throated (or specify dimensions, say, 14in. or 18in. by 6in. or 9in.) and to be 4in. (or 6in.) longer than the opening and jambs, in one (or more pieces) with mitred returns. The jambs or architraves to be of solid rubbed Portland (or other stone) each in three (or four) pieces, bonded to wall and dowelled to sill. The entabla-

ture and pediment to be moulded, as shown, and to be of the scantlings given, the architrave and frieze to be solid, in separate or single stones. The pediment to be formed of stones tailed into wall 6in. (or 9in.), and to be jointed as shown, or in five pieces dowelled together with slate in cement. The tympanum to be of three stones 6in. in bed. Or—

The sills to be of rubbed Portland (or — stone), weathered, throated, grooved, and moulded, returned and mitred ends, with stools for jambs (or mullions) worked on, with copper or slate dowels and grooved for iron tongues 1½in. by ½in. The moulded architraves to be as shown, to be in courses with the ashlar, every fourth jamb-stone being bonded through the whole thickness of wall, rebated to receive frames. (If there are mullions—)

The mullions or pilasters to be of the size shown (or 6in. on face by 9in. deep), moulded (or panelled) as shown, rebated to receive frames, and in three (or more) pieces, and dowelled together. Or—

The window dressings or jambs to be rusticated with chamfered (or moulded) joints as per detail, in courses with ashlar facing, rebated for frames, and bonded every three or four courses to wall; and the flat or curved arch to be also of rusticated stone in five pieces (or jointed as shown) with skewbacks.

27. *Plain Cornice*.—The cornice (see section 6) to be built up in two (or three) thicknesses of Portland stone, in lengths of not less than 5ft., cramped at joints with copper (or galvanised iron cramps 12in. long). The beds to be as shown in section (or give depths, or the stone to be bedded through the thickness of wall). The upper projecting course of cornice to be bedded through wall and to project 18in. (or more) from face of wall, weathered, moulded, sunk, and throated, as shown. Or—

The cornice to be in two thicknesses of stone in lengths of not less than 3ft. (or 5ft.), the lower or bed-mould course to go through thickness of wall (14in. or 18in.), and to be moulded, as shown, and project (6in.) The upper member to

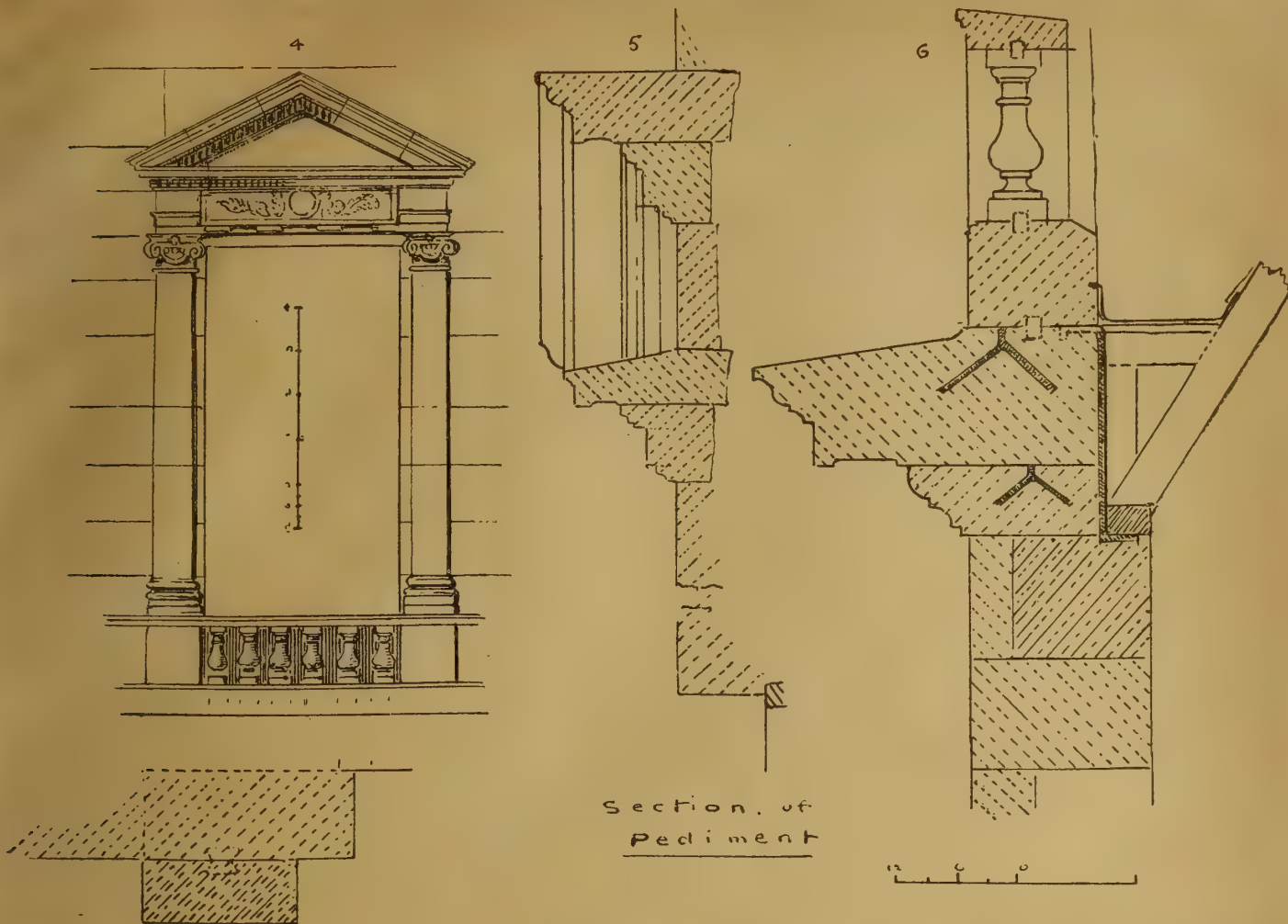

Section of Pediment

project 18in. (or more) from wall face and to go through wall (or to have a bed of lin.) The courses to be cramped at joints with copper or galvanised iron cramps, and wrought-iron holding irons are to be fixed, 4ft. long, 3in. by ½in., as shown, every 5ft. apart, and the lower end turned into walls 6in. (or under plate), and the upper end turned down into stone of cornice.

28. *Cornice and Balustrade.*—The cornice to be of Portland (or other stone), free from all defects, in two (or three) courses of the sectional form, and scantlings shown in details; no stone to be less than 5ft. (or 3ft.) in length. The enriched lower course to have modillions (or dentils) as shown, and the soffits to be sunk and panelled. These enrichments to be carved out of the solid stone, after full-size models approved by the architect and to his satisfaction. The plain parts to be rubbed (or dragged, or tooled). The main courses of cornice to go through the whole thickness of wall (or state depth, 12in. or 18in.), and at every 5ft. a flat galvanised wrought-iron bar, 4ft. long, 3in. by ½in., to be fixed with turned ends, one into the stone and the lower one into a course of the brick wall to hold down cornice. The stones to be cramped with copper or galvanised iron cramps. Fix above cornice a blocking course 12in. high and 9in. on bed (or a balustrade with plinth balusters and capping to be fixed, properly cramped and dowelled together as shown in detail. All the parts to be solid, and of the form and scantling shown. The plinth and capping to be in stones not less than 3ft. (or 5ft.) long, cramped together with slate (or copper) dovetail cramps, and each baluster to be dowelled to plinth and capping with copper or slate dowels in cement.

29. *Copings.*—Put weathered (or saddle-back) Yorkshire copings, 13in. (or 18in.) by 3in., throated on both sides, to all parapet walls, in lengths of not less than 5ft. each, with stopped ends and angle-stones. The stones to be bedded and pointed in cement, and cramped together with slate (or copper) cramps. The gables are to have apex stones, kneelers, and bonders as shown. Or—

Put Portland stone coping, 16in. by 2½in. (or 18in. by 3in.), to all parapet walls, and gables (weathered or saddle-back) with returned angles, apex stones, kneelers, and bonders jointed in cement, and cramped with galvanised iron (or copper or slate) cramps in cement.

THE ARCHITECTURAL ASSOCIATION DINNER.

THE annual dinner of the Architectural Association, marking the close of the fifty-first session, was held on Thursday evening in last week at the Holborn Restaurant. Mr. Hampden W. Pratt, F.R.I.B.A., the President retiring from office, occupied the chair, and among the eighty or ninety members and guests present were Dr. Garnett, Messrs. W. D. Caröe, F. E. Hulme, Beresford Pite, W. A. Pite, G. H. Fellowes-Pryne, E. Fellowes-Pryne, H. Fellowes-Pryne, H. T. Hare, W. H. Jamieson, F. W. Pomeroy, W. G. B. Lewis, A. S. Flower, A. G. R. Fenning, F. G. F. Hooper, A. O. Collard, A. Hessele Tiltman, Clarke Edwards, E. O. Sachs, E. A. Runtz, F. R. Farrow, J. G. N. Clift, A. W. Weedon, H. Lovegrove, A. T. Walmisley, H. Tanner, F. T. W. Goldsmith, W. J. Locke, F. H. R. Hardcastle, H. A. Satchell, D. G. Driver, &c. The after-dinner speaking was interspersed by songs from recent A. A. burlesques, excellently rendered by Messrs. F. D. Clapham, S. Constanduros, J. H. Wilson, G. B. Carvill, and Leonard Butler, and Mr. F. Imhof acted as accompanist.

The health of "The Queen" having been duly honoured, the PRESIDENT proposed the toast of "The Royal Institute of British Architects," remarking that for many years they had deservedly placed this in the forefront of their toast list. He proposed to put before them the Institute in one or two aspects—first, as that body was regarded from outside its ranks, and then as considered from within. In certain Government and other official circles, the Institute seemed to be looked upon as being at the head of the profession, and there was no doubt this was the right place for it to occupy. So far, however, as the general public was concerned, it was doubtful how far the Institute, or for that matter, the whole body of architects throughout the country, were recognised as they ought to be. Within the profession there were many able men who were outside its ranks, and personally, he held this to be a misfortune, not only for the Institute, but for the profession at large. So long as this was the case, architects were not able

to speak with that united voice and authority they ought to command. He should like to see the Institute universally acknowledged as the one representative body of the profession. For his own part, he could never understand what position another society, which he would not more definitely name, held among architectural bodies, but he hoped the time was not far distant when the society he referred to would dissolve itself and throw in its lot with the Institute. He would next ask what were the views of those within the Institute ranks. Undoubtedly many architects considered that the Institute might do a good deal better than it did at present, that it might be much better than it was, and there was a feeling abroad that considerable alteration was needed in the constitution of its council. [Hear, hear, and applause.] It was a sign of these democratic times that such a feeling should exist, and that a certain amount of reform in the council by whom it was governed should be demanded. The allied societies in the provincial towns, however, looked up to the Institute as if it were on a pedestal, and regarded it as exercising considerable benefit for the whole profession, while they also did not forget that they constituted one of the elements of the Institute's power and influence. Passing on to consider the Association's point of view of the case, the two bodies had recently been in closer alliance than when he first joined the Association, and the closer union had been of mutual benefit. For some years the Association had been represented on the Council of the Institute, and for a considerable period they had received from the Institute an annual grant of £100 towards the expenses of the classes. This sum they had not scrupled to accept, as they regarded it as money which eventually found its way back to the coffers of the Institute in the form of new Associates trained in the Association classes. He felt no doubt that the success of the Institute examinations had been materially aided by the systematic course of training given at the studio in Great Marlborough-street, and if they did not agree altogether with the manner in which those examinations were conducted, they gladly acknowledged that considerable benefits had resulted therefrom. They

ought to work hand in hand with the Institute, and endeavour to make these examinations more useful to the student. In the regrettable absence owing to ill-health of Professor Aitchison, the President, who had written expressing his hope that they would enjoy themselves with the usual hilarity, he would couple with the toast the name of Mr. W. D. Caröe.

Mr. CARÖE, in reply, expressed regret at the absence of Professor Aitchison, who at the Institute council meetings always contributed some of his brightness and mirth to that somewhat dreary body. The present was not an occasion on which to talk architectural politics, and he would only say that the Institute as a body, and more particularly as represented by its council, felt that its life-blood ran in the veins of the Association. It was a truism that youth was the hope of old age, and certainly the Association was the hope of the Institute. The more cordial feeling existing between the two bodies was of immense advantage to the profession, and also to each body. What was most to be dreaded by architects was a lack of enthusiasm. There were so many turmoils and difficulties surrounding the practice of their profession, that the time and labour required to organise and keep going societies was a serious matter, and hence they constantly required to have new blood and fresh ideas grafted on to the old. He concurred in all the chairman had said as to the need for reform in the council of the Institute. It ought to be a rotatory body, members retiring from office after two years' service, and then, after at least a year's absence, being eligible for re-election. He had been struck at the Academy Exhibition by a model design for a church, executed by a member of that Association who had been trained in their classes. It was on men of this stamp, and on those at the head of the A.A. schools, that the future of the Association and of the profession depended.

Dr. GARNETT proposed the toast of the evening, that of "The Architectural Association," in a speech characterised by much dry humour. As an outsider and layman, he disclaimed any intention of discussing its internal affairs; but he knew it was carrying on a most valuable, efficient, and important work. Not only did it prepare students for the R.I.B.A. examinations, but it also organised an invaluable form of post-examination teaching in design and water-colour drawing, such as could not be found elsewhere, and it conducted practical classes in the properties, uses, and limitations of materials, thus training the younger men to use tools as well as pencils. A still more beneficial work, educationally, in his judgment, was the fortnightly gatherings—meetings for mutual improvement, which was the best kind of improvement. Not only did they read papers to each other, but occasionally papers were read before them by experts—papers of a class which could not be got at any cost from any other source. Any young architectural student coming to London would do well to join the Association, for he would gain moral as well as intellectual strength in its classes and meetings. The Association was worthy of the admiration of all, and he would ask them to drink to its continued health, prosperity, and success, coupling with the toast the name of their hard-working President, Mr. Pratt.

In acknowledging the toast, which was received with enthusiasm and musical honours, the PRESIDENT observed that Dr. Garnett had seized on the real vital point of the reason for existence—no other name than that of the Association would so well express the aims and endeavours of that body. Their object was to work together as a band of young men, associated for mutual help and with a common desire to advance the art they loved. It would be a deathblow to the Association if this bond of union—that of mutual help—were broken. The cause of technical education was advancing so rapidly and steadily that the Association, if not threatened in its existence, was at least put on its mettle, and they must endeavour to draw the bond of union closer and closer in order to demonstrate to the student the advantages of joining their ranks. Mr. Caröe had referred to the need for enthusiasm, and this was certainly not lacking in the Association. Having referred to the remarkable Jubilee gathering of last year, the President observed that one of the matters discussed on that occasion was the necessity that existed for providing more commodious premises in which to conduct the classes. It might be thought that

the day was far distant when something would be accomplished in that direction; but he believed that ultimately their desires would be realised. At present the committee were seeking a site, and were taking practical means to that end. The Association was maintaining its financial position, and the result of the last twelve months would be held to show a better balance-sheet than for many years past.

The next toast, that of "The Lecturers and Instructors," was proposed in an eloquent speech by Mr. BERESFORD PITE. The subjects of the toast were, he said, practically those friends who filled up the gaps in the patriarchal system of haphazard self-education of the pupil which prevailed in architects' offices, a system under which the luckless youth was left to pick up his knowledge of the profession—something after the style of a fowl picking up grains in a farmyard. For the present educational system of the Association they owed thanks to their past-president, Mr. Leonard Stokes, who was the originator of the new curriculum; but although the speaker sat on the original committee, he for one never anticipated the outside support they now possessed in the form of their excellent body of instructors and teachers. The Association had for many years provided examinees for the R.I.B.A. examinations, but not the examiners. Now, however, the position was altered, and he hoped before long the Association would be represented on the examining board. What the profession owed to Mr. F. R. Farrow and his colleagues could not be lightly estimated. The quantity surveyor instructed the students how to cook, without any intention of making them quantity surveyors themselves. As to the other instructors who were not trammelled by the awful bogie of examinations, the young architect would find that every point he acquired with regard to practice and design would afterwards give an added joy to existence. A cynical friend had suggested to him that one necessary class had been altogether omitted from this curriculum. A man might have his head chock full of technical facts and figures, and his fingers might ooze with technical skill, and yet fail to attain to any success in life. The ultimate thing that succeeded in life was not knowledge but cheek; and therefore he thought it would be most desirable if some benevolent person would establish a professorship of Pure Cheek in our technical schools and universities; were this accomplished he ventured to think that architects might be found to fill a few chairs.

Professor F. E. HULME, F.L.S., whose name was associated with the toast, briefly replied, referring in the course of his remarks to the Royal Palace at Kew, about to be thrown open to the public, and which he hoped would be maintained in its present condition, and not allowed to degenerate into a mere addition to the many museums in Kew Gardens.

Mr. F. R. FARROW also acknowledged the toast, remarking that the Association was founded on principles which must bring increasing success to the school. Whenever they obtained the promised new premises, he hoped the buildings would be more soundproof than the present studio, although in this respect 56, Great Marlborough-street was an improvement on 9, Conduit-street.

Other toasts were "The Visitors," proposed by Mr. A. H. HART, and responded to by Messrs. HARE and LOCKE; and "The Committee and Officers," given by Mr. ALFRED CONDER, and acknowledged by Messrs. GOLDSMITH and HOOPER, who are retiring under the rules after three years' useful service. The concluding health was that of "The President-Elect," proposed in a felicitous and humorous speech by Mr. BANISTER FLETCHER, and having been received with musical honours, was acknowledged by Mr. G. H. FELLOWES-PRYNNE, who observed that he felt the responsibilities of his position, following as he did in the wake of such able men as his genial friend Mr. Mountford, their admirable leader Mr. Caröe, their orator Mr. Beresford Pite, and last, but not least, their most truly businesslike chairman Mr. Pratt. As architects, the one great thing they needed was *esprit de corps* and brotherhood, and these they would find in the ranks of the Association.

A new county-police station is in course of completion at Broadstairs, from plans by Mr. F. W. Ruck, of Maidstone, the county surveyor. The contractors are Messrs. A. N. Fryer and Co., who have also just enlarged the police-station at Sheerness also from Mr. Ruck's plans.

## THE SOCIETY OF ARCHITECTS.

A SPECIAL general meeting of the Society of Architects was held at the rooms of the Society at St. James' Hall, Piccadilly, W., on Thursday, May 26, at 8 o'clock p.m. Major F. S. Leslie, R.E., Vice-President, was in the chair. Mr. ELLIS MARSLAND, honorary secretary, briefly stated the object for which the meeting had been called, and then moved the following resolution, of which due notice had been given:—"That the Article of Association 11A be amended in the following manner: (1) By deleting the figures 35 in subsection A of the said article, and substituting the figures 28 in lieu thereof. (2) By deleting the figures 35 in subsection B of the said article, and substituting the figures 28 in lieu thereof."\* This was seconded by Mr. R. W. COVENTRY DICK. At the conclusion of a speech of some length, in which he criticised the action of the council, Mr. G. A. T. MIDDLETON, A.R.I.B.A., moved the following amendment:—"That the lowering of the age limit for the admission to membership of this society without examination being, in the opinion of this meeting, a retrograde step, and not calculated to improve its position, the Council be instructed to carry out the spirit of the whole of the provisions of Article of Association 11A." This amendment found no seconder, and therefore fell to the ground. Mr. G. A. T. MIDDLETON then moved, as a further amendment, "That the limit of age be altered from 28 to 32"; but this also found no seconder. The chairman then put the resolution, which was carried, there being only one dissident. This concluded the proceedings.

At the conclusion of this general meeting, the seventh ordinary meeting for the session 1897-98 was held, Major F. S. Leslie, R.E., vice-president, occupying the chair, as before.

Various donations to the library of the society were announced, and acknowledged with thanks.

Mr. CECIL TUDOR DAVIES, librarian of the Wandsworth Free Public Library, read a paper on "Libraries from a Librarian's Point of View," which we hope to give in an early issue. A short discussion followed, in which the Chairman, Messrs. Ellis Marsland, J. R. Manning, and G. A. T. Middleton took part, and a vote of thanks was accorded to the lecturer.

## A CASE OF JURISPRUDENCE IN LAND-SURVEYING.

MR. AMBROSE E. LEHMAN read a paper on May 21 before the Engineers' Club of Philadelphia upon the above subject. With the aid of a blackboard sketch he described the character of a survey of a large and valuable tract of land in a neighbouring state. This survey was made under a contract substantially as follows:—It was to include: (1) The establishment of a true north-and-south line at some suitable point on the property. (2) The survey of the outside boundary-line of the property, including the outlying lots. (3) The location of all houses, buildings, &c. (4) The principal features of the topography as far as the same are incidental to the surveys above mentioned. (5) A finished map of the whole work in all its details, on a scale of not less than 6in. to the mile. The main tract was eleven miles long and about four miles wide, and of such irregular shape that its circuit measured about 44 miles. It was soon found that the courses and distances in the deeds of record on file in the county office were inaccurate and misleading and were lacking altogether. There was no record of the date of the original surveys, nor any notice of magnetic variation at that time. The property itself was next explored in detail, and the country was found to vary from low, swampy lands to sudden and extended elevations. Three lakes of considerable area and several ponds of varying size were included in the tract, and for the most part the country was

\* The present conditions for membership of the Society, which it is proposed to alter by these changes, are: On and after November 1, 1896, election to membership will be only open to candidates, approved by the Council, who have passed an examination, with the following exceptions: (a) Candidates who are not less than 35 years of age, and have been directly engaged professionally in architectural pursuits, as principals, for at least seven years; (b) Candidates who are not less than 35 years of age, and have been directly engaged professionally in architectural pursuits, as assistants, or as assistants and principals for at least ten years. All candidates seeking election into the Society of Architects will, with the exceptions previously noted, be required to satisfy the Council that they possess a competent knowledge of architecture, building construction and materials, and modern practice.

thickly wooded. Deposits of rich magnetic ores were distributed here and there throughout the entire region, and it was soon discovered that their influence would be felt in the form of local attraction generally throughout the territory, and this became a serious and important factor in the work. In due course the work was accomplished, the whole undertaking having consumed over a year's time. A total of over 300 miles of line had been run, surveys were calculated, acreage estimated, and a map drawn, being in scale slightly larger than the contract specified, and in all its features fulfilling the requirements. The map, when finished, was promptly delivered to the company, with a report describing at length and in detail the work that had been done, and causes for the various delays in arriving at final results. A request made at this time by the engineer for a final and full settlement according to contract was refused, with the reply on the part of the company that no further payments would be made, for the following reasons:—(1) That the delivery of the map and results of the work were unreasonably long delayed, and had caused disappointment and embarrassment to the company. (2) That the lines run did not show on the ground the actual boundaries, and were misleading as to where the true lines of the property really stood. (3) That the contract bound the engineer to lay down on the ground the actual and true lines from corner to corner, after he had ascertained their position, by setting stakes and cutting a vista through the forest and underbrush. (4) That the true north-and-south line established on the property did not show the magnetic variation of the locality. (5) That where no corners were found, whether they had become extinct by natural causes, destroyed or removed to wrong positions, the engineer should have restored them to their proper place. (6) Though the map furnished was an artistic piece of work, bearing evidence of care and precision in its construction, and in all probability accurate at all points, yet it merely showed, theoretically, where the lines of the property were, and would not serve as a guide by which they could be traced on the ground. (2) That all notes, notebooks, plots, papers, calculations, &c., of whatever nature, incident to the prosecution of the surveys, rightfully belonged to the company, and were wrongfully retained by the engineer. In the engineer's protest against such an unjust view of the situation, he replied that the delay was caused by the difficulties encountered in the work, which were entirely beyond his control, and that the thorough methods employed required time and every precaution to guard against error and hasty conclusion, while in the end all were for the company's benefit, and made at a constantly-increasing expense to the engineer; that he was not legally bound to lay down the lines in their true position and cut a vista through the forest, which would have necessitated the doing of the work over again at almost the same cost of the original surveys; that a line had been staked out astronomically north and south, but, due to the local attraction, the angle of magnetic variation could not possibly be ascertained within reasonable time and expense; that where corner monuments were missing, because of the doubtful authority conveyed by the records, the engineer was not bound to restore them, and had he done so without an agreement between adjoining property-holders, he would have assumed judicial functions clearly foreign to his duties; that the map furnished the company was an exhibition of the exact conditions found on the ground, and the topography indicated would point to indestructible landmarks by which the boundaries could be traced; that as the whole work was done by contract for a stated sum, the engineer was bound to furnish only what his agreement called for; and he held that his methods and records belonged to him as long as results given were accurate. This appeal of the engineer, in the end, brought about settlement in accordance with the contract; and when the balance due him was paid, and all salaries, wages, and expense accounts deducted, he found, in confirmation of his fears, that he had lost seriously on the work. In closing, the author stated that however prejudiced our view might be in favour of the contention that the engineer could only fulfil his contract by restoring all boundary lines as originally surveyed in harmony with the courses and distances as given in the deeds of conveyance, yet such a view of the case must certainly allow the engineer, on his part, to demand that his employers provide him with a correct record of the field-notes of these surveys,

showing where every position was taken by the instrument used, its character and equation, the length of every sight, &c.; for without this exact data it would be manifestly impossible for him to reproduce the original results or lay down the lines as they were before all signs of their position had disappeared.

#### PROFESSOR BANISTER FLETCHER.

IN connection with our notice of the Art Metal Exhibition at Westminster we reproduce the bust of Professor Banister Fletcher,

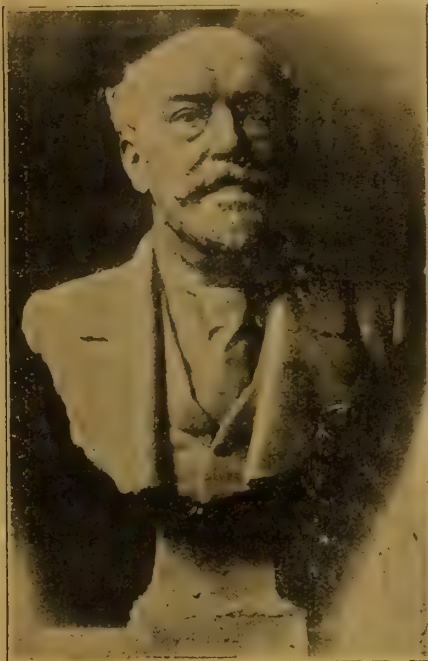

PROFESSOR BANISTER FLETCHER,  
V.D., F.R.I.B.A., J.P., D.L.

(J. NESFIELD FORSYTH, Sculptor.)

to whose exertions, as chairman of the council, the success of the arrangements has been mainly due.

The bust is by Mr. J. Nesfield Forsyth, and is in this year's Royal Academy.

#### ART METAL EXHIBITION AT THE ROYAL AQUARIUM.

ONE of the best and most complete collections of art metal-work of ancient and modern times has been opened at the Royal Aquarium, Westminster, and is well worth the attention of all architects and art craftsmen. The incompleteness of the stands and the catalogue make it necessary to pass lightly over some of the exhibits. The ground floor of the hall is occupied by several large and important stands. One of the most conspicuous specimens of wrought ironwork is the pair of wrought-iron carriage gates exhibited by Messrs. Lindsay, Neale, and Co., Ltd., of North Wharf, Paddington (Stand No. 33). The design is bold, and the workmanship of high-class character. The gates are surmounted by a very effective ramped and scrolled head, in which the broken curves of Italian Renaissance character form structural lines, connecting the smaller scrolls. Bold acanthus foliage hammered out gives shadow and firmness to the curved bars. Below this is an open frieze of scrollwork. The main panels of the gates are ornamented by centre scrollings and leafage of beaten or embossed iron, which form oval-shaped medallions, enriched by floral devices of the rose, shamrock, and thistle. The rectangular bars of the gates also terminate at top and bottom with leafage and scrolled ornament, arranged so as to strengthen the rivet connections with the main framework. Each gate has side open-work pilasters, which give variety and structural character. The specimens of railing and staircase panels and wrought-iron sashes are also deserving attention, both for design and craftsmanship. As an example of artistic metal-work, the hammered-iron lily and leafage can hardly be surpassed. A very useful class of exhibits in the

hall is that illustrating metal casements. Messrs. Burt and Potts, of York-street, Westminster, have a model of a three-light mullioned window, fitted with their well-known wrought-iron and cast gun-metal casements and windows. These are made to open either inwards or outwards. The grooved and flanged bar sections are so made as to form an effectual barrier to rain; the double-grooved section is admirably adapted for this purpose. These casements are hinged at the sides, or are pivoted vertically near the centre to allow of the outside of casement being cleaned. The upper lights are also arranged to open partially inwards, and the opening bars, fastenings, and adjustments are made to allow the blind to be drawn down without hindrance by the usual projecting arms—a very great advantage over the ordinary casement apparatus. One of the casements and upper lights is filled with a very artistic design in leaded glass.

Mr. Henry Hope, of Lionel-street, Birmingham, has also, in Stand No. 31, a number of his excellent metal casements, hinged both at side and at top to open outward, and a casement which swings on pivots not quite in centre for cleaning purposes. These are fitted with gunmetal condensation channels at the bottom formed of two grooves. The sections of bars are designed to give a watertight security. The swinging casements with screw-gear also exhibited appear to be all that can be desired. We notice, too, a very interesting case of ornamental latches of forged iron, some of them copied from old examples in Warwickshire, Sussex, and Surrey; also some very nice gunmetal handles and latches of excellent design and workmanship. The factory sashes of rolled iron bars with a middle light which falls inwards, and can be adjusted on quadrants with movable stops, is a very useful and desirable improvement on the forms usually seen. A very artistic effect is obtained in one of the small casements by the leaded light with colours obtained by selected Norman glass. The pattern, a conventionalised pomegranate, is exceedingly effective and simple.

The N.A.P. Window Co., Ltd., Victoria-street, Westminster, have a very large stand (No. 38) in the east section of hall. The N.A.P. sashes and casements of metal and wood hung to open inward or outward, or both, are well known to the profession, and we can simply advise our readers to pay the stand a visit. They will there see every kind of sash and casement fitted and in action. The "slip-tongue" and "double-knuckle" metal casements which open in and out are especially deserving of notice. The company show several patented arrangements of metal casements, which open outwards for ventilation and inwards for cleaning, also the N.A.P. sliding and revolving sash for cleaning, which can be adapted to any existing sash window, an arrangement at once simple and secure. The Asylum weightless frame with balanced sashes is a most desirable form of window for large offices and institutions, and secures the best kind of ventilation. Several iron lights, centre and bottom hung, are also shown.

J. Starkie Gardner and Co., Albert Embankment, Lambeth, have a handsome pair of entrance-gates in wrought iron, in which the plain forged finish is seen. It is a very fine specimen of modern design and workmanship. Pilasters of open scrollwork and hammered leafage, surmounted by a handsome frieze enriched by shields, figured escutcheons, &c., form the main framework. The design is elaborate, and illustrates much of the later periods of wrought-iron design, especially in the intersecting work of the bars, and other details. The same firm exhibit some other work—balcony and panels, and screens, and other examples, all worth study. Messrs. Edgar Keeling, Teale, and Co., Ltd., Ravenscourt-square, show some interesting examples of wrought iron, and works in silver, brass, copper, &c., some screens and candlesticks of copper, and iron stands for lamps.

J. E. C. Carr (Stand 44), Manchester, shows a few highly artistic examples of beaten or repoussé work, finger-plates, locks, and handles, some hand-wrought copper, and modelled metal mosaic wood. The repoussé copper and brass panels on wood are very decorative, and broad in treatment.

In the South Gallery, several stands of noted firms are to be seen. The Coalbrookdale Iron Co., Victoria Embankment, have a large and pleasing assortment of their well-known artistic fireplaces in cast iron, bronze, metal, and brass. It is needless to say there is a quietness and

breadth in many of these designs which must appeal to the profession. The cast-iron mantel-pieces, painted in simple colours or greys, the grates, railings, the gates, balustrades, and other architectural ironwork which this company turn out are examples of English Renaissance design, and the castings are remarkably clear and sharp. The cabinets and over-mantels and the simpler fireplaces with Wedgwood medallions are unique, and the railings and newel in cast iron are worth inspection.

Messrs. Perry and Co., of Grafton-street, Bond-street, have made a special feature of their electric-light fittings, which are of a very ornamental kind, in the styles of the Renaissance, Louis XV., and other periods. Chased and gilt ormolu lustres for the lights of the future, wrought and mercury gilt electric lustres, ceiling pendants, brackets for walls, candelabra floor and table lamps, grille lanterns, and every appliance and requisite for the fitting up of the electric light that the art of the metal craftsman can furnish may be found in this stand (No. 4). We particularly notice a pair of bronze standards and several three-light Louis XIV. electric candle brackets.

Messrs. Strode and Co., 48, Osaburgh-street, Regent's Park, whose work is always good, have a very comprehensive stand, comprising "leading specialities" of their manufacture. We can only here mention a few of the most noticeable exhibits they have on view. Their wrought-iron work is of excellent design and workmanship; we notice a wrought-iron dog-grate for wood fire, very well treated; a very beautiful wrought fire-screen with leafage and flowers on the ornamentation; a wrought-iron lantern and bracket, of pleasing shape; newel lights, standards, and table lamps stamped and chased. An electric-light standard of beaten brass and polished iron is another object. The finger plates of brass and electro or white metal, and the lock handles in repoussé copper and white metal are artistic in feeling, and decorative, and we advise all interested in electric-light fittings, electroliers, brackets, and other art iron and brass work to pay a visit to Messrs. Strode and Co.'s stand.

Mr. George Wragge, of Wardry Art-metal Works, Salford, Manchester, has, in stand No. 20, a very choice collection of just those little fittings and finishes in metal which go to brighten and finish a building. The metal work is of an exceedingly artistic character. We notice a number of very simply-treated embossed finger-plates and handles in white metal and brass or copper, also some very pleasing hinges enriched at the ends by embossing or chased work. A wrought-iron hammered grille with bold foliage is exceedingly clever in design. The hammered leafage and stems of the upper part are very effective.

Messrs. Hayward Brothers and Eckstein, Ltd., Union-street, Borough, S.E., have a world-wide reputation for ironwork and fittings of a structural character, and their stand contains many things of interest to architects and builders generally. Here, in stand No. 25, which no one should miss, we see every pattern of Hayward's patent non-slipping pavement light, fitted with the semi-prism lenses, their safety, self-locking coal-plates, &c. The improved straight and spiral staircases we lately described, made by this firm, are seen in two or three examples, and excellent in sharpness and finish they are. Hayward's patent "Jhilmil" metal lathing forms a background to the exhibits of this stand, and its several different applications for walls, partitions, domical ceilings, and moulded work can be seen. Here also we have specimens of Cottam's well-known stable fittings and ventilators.

The choice and artistic stand of high-class work exhibited by Messrs. Barkentin and Krall, of Regent-street, is worth inspection. The altar and processional crosses, jewelled and richly chased, the candlesticks (two of solid crystal) and sanctuary lamps, and other ecclesiastical work are of high-class design and workmanship, and there is also some finely-wrought domestic work.

Other stands, such as those of Longden and Co., who show some very well-designed fireplaces of repoussé metal plaques, and hammered wrought-iron panels with repoussé or copper flowers, and flowers, sconces, and brackets, are worth attention but we must notice other exhibits next week.

The Loan Collection on the upper floor is a valuable and most interesting feature of the exhibition. The want of a catalogue, which has not yet been printed, has prevented us from describing in detail this collection. The exhibits

comprise loans from the Queen, the Dukes of Norfolk and Westminster, South Kensington Museum, Elkington and Co., and many other private collections. The cases lent by her Majesty of inlaid firearms, stocks and barrels, and the splendid bronze repoussé plaques found at Kew are alone replete with interest to all lovers of artistic metal-work. These latter specimens are in a capital state of preservation, sharp and defined, the high relief figures representing some incidents of the 18th century, if we are to judge from the style of dress of the figures. The cases lent by the Duke of Norfolk contain many beautiful specimens of metal-work, a jewelled cross, inlaid caskets, and other objects. A case of pistols, barrels and locks, inlaid with gold and silver, signed Nicolin, French 18th century, and some Spanish firearms, inlaid, of the 17th century are of much interest. The carbines and pistols, inlaid with ivory and engraved, of "wheel" and match-locks and flint-locks, are unique, and a few specimens of Damascene work are to be seen. But the principal attraction in the collection is several very fine suits of steel-plated and ornamented armour, as in the cases lent by the Queen, Mr. Seymour Lucas, A.R.A., and the Dukes of Norfolk and Westminster. Here we see helmets, breastplates, gorgets, shoulder, thigh, and leg-guards, gauntlets, some of them fluted, others engraved and gilt.

Mr. David Currie lends a case of breastplates, purse-mounts, and cabinets. The purse-mounts are chased and embossed or incrustated with gold. The cabinets have steel plaques of repoussé work with medallion heads, figures, birds, &c., on a gold ground, and are French of the 16th century. In the annexe is a fine collection of old hammered work, and of cast fire-dogs and fire-plates. On the whole, the student of old metal-work and armoury will find much in this collection of a special character, many of the subjects never having been exhibited before.

#### FOUNDATIONS AS APPLIED TO LONDON BUILDINGS AND RIVERSIDE FOUNDATIONS.\*

(Continued from page 741.)

THE HENNEBIQUE SYSTEM OF CONCRETE CONSTRUCTION.

IN this system, in addition to the use of iron bars or rods to resist tensile stress, a stirrup is inserted at intervals, with the object of holding up the tension members. These stirrups are placed nearer together at the ends of a beam than in the centre, and the system is designed, not only for floors, but for spreading the weight of a superstructure over an extended foundation of soft ground. The calculated strength is the resistance of the iron added to the resistance of the concrete. In the execution of a contract for demolishing an old building in Maiden-lane, London, and building a new one, three stories below ground and ten (subsequently reduced to seven) above, where the site adjoined a court 3ft. wide, upon the opposite side of which was a four-story warehouse, the contract arrangements did not permit of the removal of the soil of the court, and the underpinning of the wall to the warehouse; so the ground had to be kept up with the superincumbent weights all round. The contractors timbered with 2in. polings, aided by 9in. and 12in. timbers, both for struts and walings. This, however, proved quite inadequate at a depth of 30ft. to 42ft., the latter being the depth of the bottom of the trenches. The weight caused the 12in. logs to bend as much as 2in. in the distance of 5ft., at which the cross-struts were spaced. As a consequence the houses all round, and particularly the warehouse across the court, began to indicate signs of settlement. The thickness of the retaining wall was increased, and inverted introduced, and struts placed. Difficulties as to the projection of the area into the street prevented the contractors carrying the excavation to the full extent shown upon the plan when the excavation was commenced; consequently, at a later period, when the building appeared above ground, the front planking and timbers had to be taken out, about one-sixth more earth excavated along the frontage, and the ground retimbered. When this process had reached about 30ft. out of the 42ft. an accident occurred. This timbering gave

way at midnight, and let into the basement of the building the whole of the earth above, due (as the contractor believes) to some soakage going on in the blue clay and causing it to spew out at the base. The gas and water mains in the narrow street became broken and the sewer injured. The site appeared to be smothered in liquid mud 30ft. deep in the trench. Probably if sheet piers not less than 3in. thick had been driven close together, joint to joint, anxiety might have been relieved by the use of additional struts. The employment of 2in. poling boards—which the author understands to mean 2in. boards thick inserted behind the walings at slight distances apart—is only effective where the ground is self-supporting, or nearly so. In ground of a loose kind, close sheeting in all such excavations is absolutely necessary.

#### DEPTH OF THE LONDON CLAY.

In the construction of the Central London Railway the clay has been reached at a depth of 29ft. 6in. below the surface at the Bank Station adjoining the Royal Exchange, at 20ft. at Chancery-lane, and 21ft. 3in. at Davies-street, Oxford-street; the excavation in the shafts indicating 12ft. of made ground over 18in. of loam and 16ft. of gravel at the Bank Station, 6ft. of made ground over 14ft. of gravel at Chancery-lane, and 12ft. 6in. of made ground over 8ft. 10in. of hard mud in Oxford-street. While at some places the ballast has been found almost immediately below the surface, there are other places where the solid stratum of gravel underlies marshy ground to a depth of 15ft. or more. In underpinning an existing structure when building an adjoining structure, the foundations for which are required to be at a greater depth than the existing building, the work should be set out so as to be executed in sections of about 5ft. to 10ft. in length, one length being completed before the adjacent length is commenced, and each succeeding section inserted, so that one or more undisturbed section or space of 5ft. to 10ft. is allowed to exist between the section in course of progress and the last finished section. The wall which is underpinned will thus stand on piers 5ft. to 10ft. long, with undisturbed ground intervening. When the stratum of earth on which the piers are built does not prove strong enough to sustain the load upon the piers—an occurrence which cannot be ascertained until excavations are made—the intervening bays should be excavated and the foundations made continuous; but in this case the process of needling up is indispensable. Care must be taken in fixing the needles to leave room to excavate and to fill in between needles before drawing them; also to employ a proper use of raking and shoring pieces, and filling in of window openings as may be essential to obviate danger to the structure, and take care to build up the section with the quality of brickwork suitable for foundations. In

#### UNDERPINNING WORK

brickwork is usually preferred to concrete, because it is easier to insure tight packing under the old work. Concrete has, however, been successfully used to underpin buildings when carried up to within about 1ft. or 18in. of the old work, and then allowed to set for at least a couple of days before ramming in the remainder with iron rammers, the concrete so used being in a semi-dry condition, and care being taken not only to board up the face and wedge the boards tight against the face of the plastic concrete, but to hammer the boards well in, so as to insure uniform support to the concrete until it has set. Having underpinned in narrow sections of brickwork upon a concrete foundation, the next step is to grout up and properly make good to existing work, and allow this to set for, say, seven days before the next section is disturbed. Where concrete without brickwork is adopted for underpinning, the time needed for setting is longer, and as underpinning is usually employed in piers, the employment of brickwork is a more speedy operation.

#### IRON SHEETS AND DRY SAND FILLING.

In the case of some residential chambers being built upon the site of Cleveland House, St. James's-square, consisting of eight floors, including basement, to the design of Messrs. Rolfe and Mathews, it became necessary to underpin the old wall of the adjacent building, 20, St. James's-square, under the care of Mr. T. Garratt as architect. The old building, the wall of which had to be underpinned, consists of five floors,

\* By ARTHUR T. WALMSLEY, M.Inst.C.E. A paper read before the London Architectural Association on Friday, May 20, 1898.



including basement, and the strata is dry sand. The whole of the underpinning consisted of picked Fletton bricks in cement, resting upon a good bed, attained at the depth excavated in the sand. No concrete was used under the old wall of this adjacent building. The underpinning was carried down in piers under the existing footings to 12ft. to 13ft. below the basement floors, in places where steel stanchion foundations were introduced in the new building to carry the floor girders. The remainder of the wall was underpinned to an average depth of 5ft. 6in. below the basement floor, which is about 11ft. below the road level, or a total depth of about 16ft. 6in. The foundations to the walls of the new building are concrete, and to insure a straight joint between the old and new building, thin sheets of iron were placed between the brickwork of the old building and the concrete of the new building in the foundation and dry sand filling between the old and new work above this level, so that the new work can settle quite independently. The old wall of 20, St. James's-square, varies from 18in. to 27in. in thickness, the adjoining new wall of the residential chambers being 22½in. at the basement floor. The excavations were made so as to build piers in 4ft. to 6ft. lengths, leaving a similar length between each pier undisturbed until these piers were set, a minimum of four days for this purpose being required. The intervening space was then cleared, and the underpinning completed to form a longitudinal continuous support. Where cross walls appeared, the underpinning was carried about 2ft. 6in. under the cross wall beyond the longitudinal underpinning. In the improvements recently effected at the Lord Warden Hotel, Dover, several interior walls upon the ground floor were removed to form an area facing the main entrance suitable for a lounge. It being decided to carry the stanchions, which had to be inserted to support girders carrying the upper walls, upon the lower existing walls, Messrs. Handyside and Co., the contractors, introduced 10in. by 6in. rolled steel joists 6ft. long, as distributing girders, over which a cast iron bed-plate rests, and between this bed-plate and the foot-plate to the stanchion very flat steel wedges were introduced, tapering from ¼in. to ½in. in a length of 2½in., the object being as follows: The wall being properly needled up, the lower portion is removed, the girder inserted, bearing on the stanchions. Brickwork is then built over the girder, and the wedges to stanchions so adjusted that, by assuming the curve shown below, the girder is given work to do before the remaining brickwork is inserted. By this means further deflection is obviated, and subsequent cracks in the existing upper wall are avoided.

#### STEEL STANCHIONS AND DISTRIBUTING GIRDERS.

In the building of the new Carlton Hotel, Haymarket, the old walls of the Opera House foundations were left intact, except where the contractors found it necessary to cut through them, for purpose of the new work. The formation was tested to 36ft. 6in. depth below street level, and found to be loamy sand, suitable for foundation. The new front walls are all solid foundations upon continuous concrete. Portland cement concrete (six to one) 3ft. thick was placed under the main walls and under the intermediate walls, everywhere of the same thickness except under the 9in. walls, where 2ft. thickness was adopted, and under stanchions, where a base 9ft. square is used, 4ft. in depth. There is not more than 2ft. difference of level in the top of all the concrete, a difference necessary to suit the floors. The solid columns, 8½in. diameter (hammered steel ram), are carried on a cast-iron base plate, 2ft. 8in. by 18in., seating on five rolled steel joists, 18in. by 7in., imbedded in the concrete, each 7ft. long. In some cases four rolled steel joints are used, carrying a solid rolled steel column 7in. diameter. The stanchions are embedded in the brickwork where walls permit, and carry the wall girders. All brickwork is in cement throughout. For large weights, solid blue brick piers in basement support stanchions. The wall next the arcade had to be underpinned by piers 18ft. deep. This wall formerly took the roof of the arcade only, but now supports the side wall of the hotel and seven floors. Six distributing rolled joists, 10in. by 4½in., are inserted to carry the weight of the upper wall on top of crown resting on brickwork. A stanchion was built into each pier, leaving about 2ft. of the face-work next the arcade intact. New arches were inserted, using the old arches as centres. The

old arches were then cut out, and the new piers carry the arcade roof and hotel wall at this side. The stanchions, with the surrounding brickwork, carry the springing of the arches. Two 12in. by 3in. channel sections, with two 16in. by ½in. plates form the stanchion, 13in. by 16in. over all. Four rolled joists carry a 16in. square stanchion, 20ft. 2½in. long, with steel  $\square$  riveted to the stanchion at the base, and a 11in. column above this, 22ft. 5½in. long, making altogether 42ft. 8in. in height. The stanchions and columns are employed for interior walls only. The 7in. columns, 24ft. 3in. over all vertically, have a base plate 2ft. by 18in., and the construction erected by Messrs. R. Moreland and Son is an interesting example of the use of solid steel stanchions and of distributing girders in foundations arranged with the aid of a cast-iron base-plate to give a pressure not exceeding 1½ tons per square foot. Mr. H. L. Florence is the architect.

#### CYLINDERS V. SCREW PILES.

At Great Yarmouth, within two years of the building for the town hall being completed, it was found that the western portion, near the river, was settling considerably, and levels were taken monthly, with the result that Mr. Cockrill, the borough surveyor, found these settlements were continuing, especially after heavy rains, or very high or very low tides. The late Sir J. Bazalgette was called in, and he recommended underpinning and building walls under present foundations with concrete blocks. Borings were made showing 6ft. of made ground and 18ft. to 20ft. of soft ooze, below which was gravel. Mr. Cockrill carried on the works under Sir Joseph Bazalgette's instructions. The method of procedure was to sink two cylinders entirely without pumping, a grab being employed to remove the soil inside cylinders, and divers to level and sink them. These were sunk to a depth of 40ft. A trench was opened from the cylinder out to the north-west corner of the building, but immediately on commencing to pump, a settlement was necessarily caused in the building, which so frightened the municipal authorities that they stopped the works, and, of course, as the water rose in the soil, this finished all chance of doing anything further with it. Mr. Cockrill, however, is very strongly of opinion that if he had allowed the matter to have gone on he could have underpinned the corner in forty-eight hours, and when one corner was done it would have been a comparatively easy job to have continued. Sir Benjamin Baker next came on the scene, and with Sir Joseph Bazalgette recommended widening the present foundations by using the concrete blocks made for underpinning. The committee, however, resolved to pull the west part of the building down; but subsequently, upon the advice of Mr. F. E. Duckham, screw piles were introduced. Mr. Duckham's plans consisted of putting rows of cast-iron screw piles at intervals of 9ft. inside and outside the main walls, each about 23ft. long, screwed approximately 3ft. into the gravel bank. On the heads of these piles, longitudinally and parallel with the wall, were placed girders about 15in. deep, and across them, suspended by strong screw bolts, steel joists were placed under the concrete foundations, and then screwed up tight to the concrete, the whole being surrounded with concrete. No settlement has since occurred. The subsoil consisted of a gravel bank underlying 16ft. to 18ft. of ooze and 5ft. or 6ft. of made ground, into which the trenches for the concrete foundations were cut. The removal of the water from these trenches tended to jeopardise the building. The piles employed were 2ft. 6in. and 3ft. diameter filled with concrete, so that in the event of the cast iron becoming injuriously affected by the soil of the district the internal concrete columns would sustain the superimposed mass. In the construction of the Liverpool Overhead Railway, wrought-iron girders placed 22ft. centre to centre, at a normal span of 50ft., and at a height of 16ft. above the roadway, are supported by columns built of two steel channels and two plates grouted at their base into cast-iron shoes, which are anchored to concrete foundations by bolts, the concrete footings being arranged so as to distribute a pressure of one ton to the square foot over the surface of the made ground on which they stand. The

#### SAFE BEARING POWER OF VARIOUS KINDS OF GROUND

may approximately be stated as follows:—Made ground, when dry, as firm earth, will sustain from

2,500lb. to 3,500lb. per square foot, or, say, from 1 ton to 1½ per square foot; but if the subsoil be of an alluvial character, or quicksand, it will be prudent to allow only ½-ton to ¾-ton per square foot, and the same for soft clay near the surface, whereas with moist clay we can allow from 1 ton to 1½ tons per square foot; compact clay, nearly dry, from 2 tons to 2½ tons per square foot; dry, compact clay, of considerable thickness, from 3 tons to 5 tons per square foot; loose sand, from 1 ton to 1½ ton per square foot; compact sand, from 2 tons to 3 tons per square foot; compact sand, prevented from spreading, from 5 tons to 7½ tons per square foot; ordinary gravel and sand, from 2 tons to 3 tons per square foot; but, if the same be compact, dry, and prevented from spreading, from 4 tons to 6 tons; while ordinary rock would safely carry 9 tons per square foot. In the case of the Tower Bridge, it was thought expedient to limit the pressure on the London clay upon which the piers rest to 4 tons per square foot. When the bridge is loaded to its utmost capacity, it is calculated that the granite bed under the columns of the towers sustains 16 tons per square foot, and the Staffordshire blue brickwork immediately beneath the granite 10 tons per square foot. At the Imperial Institute, designed by Mr. T. E. Colcutt, the pressure produced by the foundations upon the blue clay is estimated to be 2½ tons per square foot. The main walls are continuous, but the wing walls are carried by girders attached, in some cases, to stanchions built into brick piers, as shown in the diagram, so as to obtain easy communication in the basement area for pipes and storage connected with exhibition purposes. The stanchions, where introduced, are 14ft. 5½in. over all, and stand on concrete foundations. The outside walls are carried down 14ft. to 19ft. below street level. Clay, when dry, and retained or excavated to a flat angle, is a safe foundation; but mixtures of sand and clay are bad, the sand admitting water, and the clay retaining it. In such a soil, 2 tons per square foot of foundation is sufficient to assume. Landslips in clay occur when a clay bank is left insufficiently protected, or at too steep a surface. In many parts of the Midlands, where it is the immediate subsoil, structures built thereon are apt to slip, and end walls of houses to crack, owing to the shrinkage of clay due to excessive dryness. A landslip occurred on the South London line of the London, Brighton, and South Coast Railway, upon the south side of the line at Denmark Hill Station, where the railway passes in a cutting, having an average depth of 25ft. along the side of the hill rising to the southward, and consisting of London clay. The slopes of the cutting were laid as flat as the limits of the land acquired would allow, and, in order not to encroach on the public road called Champion Park, a surcharged retaining wall was employed to uphold the slopes. For a period of about twelve years after the railway had been opened for traffic the retaining wall appeared quite sufficient to withstand the pressure of the earth behind, although some slight slips occurred on the surface of the slope; these being dealt with in the ordinary way—by taking out the slips and filling up the place with chalk. Later on, owing to a movement in the wall itself, more vigorous measures were adopted, and heavy concrete buttresses were put in below the foundations of the wall, and brought up to the level of the platform. This remedy answered for a time, but the mischief was still going on, and during the winter of 1881 made itself apparent by a further movement of the wall, a sinking of the roadway in Champion Park, with a corresponding rising of the permanent way, which was lifted 2ft. It was therefore decided to put in another wall at the back of the old one, sufficiently deep and heavy to resist the pressure of the moving clay. This was done by the construction of a wall 12ft. in thickness in Portland cement concrete, the foundations being carried down to a depth of 18ft. below rail level of the solid ground, undisturbed by the slip. In addition to this wall, which was built for a length of 400ft., traverse counterforts, 5ft. in thickness, were put in about 13ft. apart, extending from the back of the wall up the slope to the road above, a distance varying from 20ft. to 50ft. The cause of the slip was probably owing to the accumulation of water in the ground forming the slope behind the wall. The retaining wall at the west end of the station also showed signs of moving, and this was strengthened by building raking buttresses in cement brickwork, with intervening arches against the face of it, with concrete foundations carried down to a

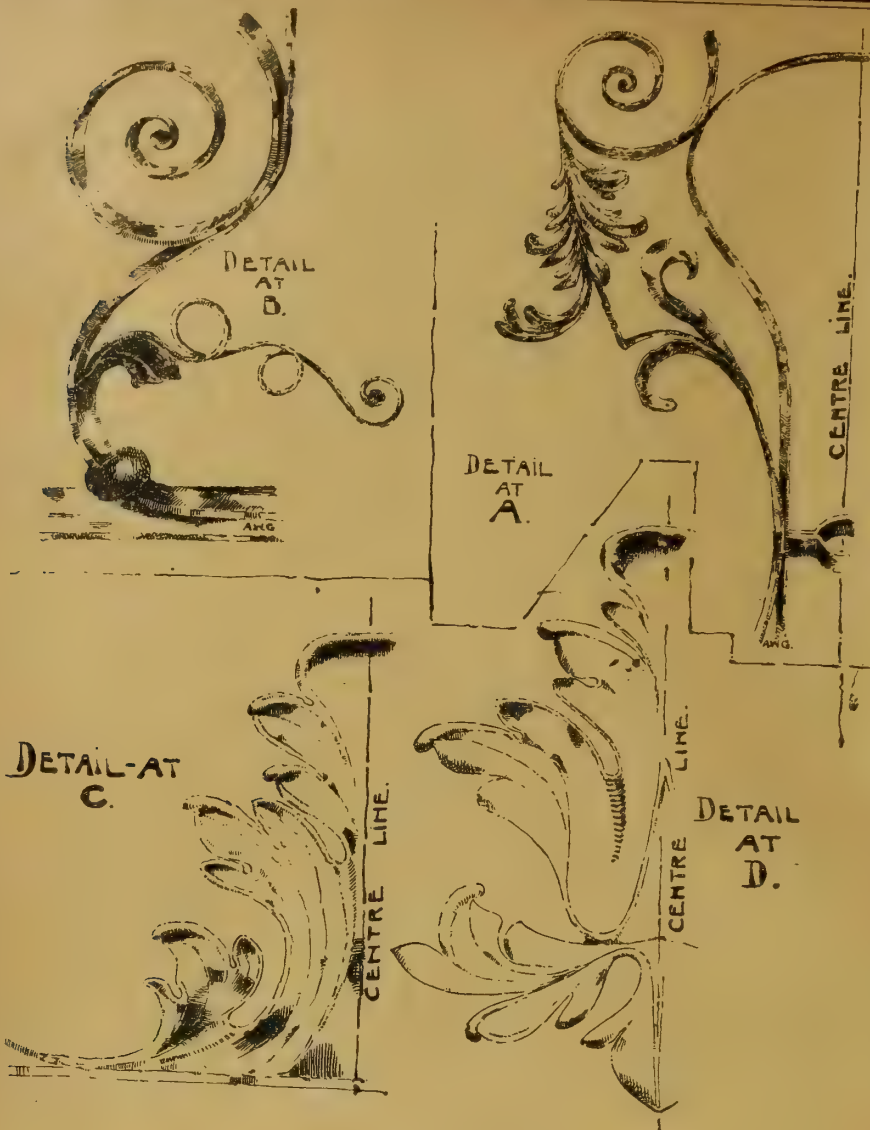

station in the Farringdon-road are carried down to a depth of 16ft. below the rail level. The piers are of Staffordshire blue bricks set in cement, and are built upon footings of concrete that rest upon the London clay.

TUNNELS UNDER WAREHOUSES.

The Great Northern Railway Company constructed an additional tunnel under some large warehouses in the Brewery-road, Islington, without the removal of any of the heavy stock contained in the warehouses or compensation for stoppage and loss of trade to the owners. The tunnel was built in 6ft. lengths, and as each length was tunnelled out it was arched in at once and neat cement worked in by hydraulic pressure between the arch and the ground above, each length being completely finished before a fresh one was started. Messrs. Holland and Hannen, of Bloomsbury, London, constructed at the Surrey Commercial Dock some new warehouses in the South Dock on concrete piers varying in depth from 22ft. to 29ft. The borings showed the strata in various positions on the site to be in most cases made ground, blue clay, peat, silty clay, sand, and gravel. There were altogether some 250 pier-holes to be excavated, 4ft. 6in. square, and averaging about 20ft. below the surface of water in the dock immediately adjoining. It is obvious that to have kept each pier-hole separately pumped out during operations would have proved an endless task. A large sump-hole was, therefore, formed in the centre of the site, and by these means the water strata was tapped, and by constant pumping the pier-holes were kept sufficiently dry to work in. Some considerable difficulty was experienced with the pumping machinery at the commencement, as ordinary pumps were useless in consequence of the large amount of sand extracted with the water. Centrifugal pumps were tried, but without success, and eventually a Murray's endless chain-pump was erected, which worked satisfactorily until the pier-holes were completed. The City and Southwark Electric Railway, in its course between the Middlesex side of the river and the Monument terminus, passed up Swan-lane near some heavy warehouses tenanted by Messrs. Harker and Co., 102 and 103, Upper Thames-street, spice merchants; Messrs. Walker and Co., Old Swan-lane, packers; Messrs. Davies and Royle, 3, Old Swan-lane, wholesale stationers; Messrs. Wigan and Co., 2, Swan-lane, importers of isinglass. Near the latter warehouse, immediately adjoining the route of the subway, the tunnel left the clay and entered the water-bearing strata. These warehouses have basement, ground floor, first-floor, second floor and top-floor space, all occupied, some rooms being used for heavy papers, other for cases containing various kinds of fruit and general heavy goods. When the subway works were commenced, various old cracks were found to have existed in these buildings, which gave rise to the apprehension that some danger might occur in the construction of the new tunnels, or by the subsequent working of the railway, so that certain marks were noted, and pieces of paper were pasted over various old cracks, and in other cracks cement-filling were put in, levels of doors and sills taken, and the buildings plumbed both in and out near the angles. This was in the year 1887, before the construction of the tunnel commenced. At Messrs. Wigan's they had an engine (10H.P.) constantly at work upon the ground floor, which would have run irregularly in the event of settlement. Swan-lane is about 13ft. 6in. wide, and the tunnels are there placed one over the other. Compressed air behind a bulkhead was employed to restrain the advent or inflow of water into the space excavated, and no settlement of the upper surface resulted, the water-bearing strata being never without support.

(To be continued.)

DRAWINGS BY CHARLES KEENE.

IN the BUILDING NEWS for January 21 last we published some very interesting sketches by the celebrated *Punch* artist, the late Charles Keene, and in our notes accompanying these illustrations we said, "The old church . . . is unnamed; possibly some of our readers may identify it. This would be an advantage." We have now been favoured with the desired information by Mr. E. Terrell, of Seaton, Devon, who says that the building is none other than the parish church of St. Gregory, at Seaton. He says: "I have attended the church constantly

depth of 10ft. below the footings of the old wall. Three concrete counterforts, each 12ft. by 10ft., and 28ft. high, carried down 10ft. below rail, were also introduced at the extreme west end of this retaining wall. About 10,000 cubic yards of concrete were put in. The works enumerated above were commenced in December, 1881, and completed by August, 1883. The works, as carried out, have proved effectual in arresting the movement of the earth, and no further trouble has been experienced at this place. The following table shows the angle at which different materials may safely be allowed to have sloping banks:—

only wrought iron employed being for the connecting-bolts. The old bed of the Fleet River crossed the site where the viaduct is carried across the valley, and the bed of the existing Fleet sewer was about 22ft. or 23ft. below the old level of Farringdon-street at the point where the principal arch of the viaduct spans that street, upon the skew. This bed is clay. The scare created as to the fracture of columns or masonry in the piers was due entirely to bad face joints in the bedding of the granite work. There was evidence of stability in the foundations, as not the slightest movement had taken place. The excavations for the foundations were carried 7ft.

TABLE OF ANGLE WITH HORIZON.

Earth.	Rankine.	Wray, Unwin.	Molesworth.	Natural Slopes.
Dry sand and mixed earth	37° to 21°	—	—	1.33 to 1
Sand, fine and dry	—	37° to 31°	—	2.63 to 1
" " wet	—	26°	—	—
" " very wet	—	32°	—	—
Dry sand	—	—	35°	—
Sand	—	—	22°	—
Shingle and gravel	48° to 35°	—	—	From
Loose shingle	—	39°	—	0.9 to 1
Shingle	—	—	39°	1.43 to 1
Gravel	—	—	40°	—
Clean gravel	—	45°	—	—
Gravel with sand	—	26°	—	—
Damp clay and drained	45°	45°	45°	1 to 1
Wet clay	17° to 14°	16°	16°	3.23 to 1, and
Dry clay	—	29°	—	4 to 1
Peat	45° to 14°	45° to 14°	—	1 to 1 and 4 to 1
Vegetable earth, dry	—	29°	25°	—
" " moist	—	45° to 49°	—	—
" " very wet	—	17°	—	—
" " punned	—	66° to 74°	—	—
Compact earth	—	—	50°	—
Rubble	—	—	45°	—

The Farringdon-street bridge of the Holborn Viaduct is remarkable as having a platform constructed of cast-iron arches and floor-plates, the

and over below the old bed of the river into the solid blue clay and concrete. The foundations of the Great Northern Railway Company's goods

during a residence of seventeen years, so that it is well known to me, and in every detail the drawing corresponds with the building and its surroundings, even to the tombs and the trees in the churchyard, and the pathways." We are glad to be able to give this information, and it adds much to the interest of the matter.

IRONWORK AT SOUTH KENSINGTON MUSEUM.—IV.

By G. A. T. MIDDLETON.

V.—A PAIR OF MACE STANDS.

FLIMSY to excess, yet admirably chosen as an example of much of the ironwork of the latter half of the 17th century—as well as of the next hundred years—is the pair of mace stands from the corporation pew in the parish church of Newcastle-under-Lyme. Constructional supports are lacking, and their place taken by curved members, sufficient doubtless for the actual

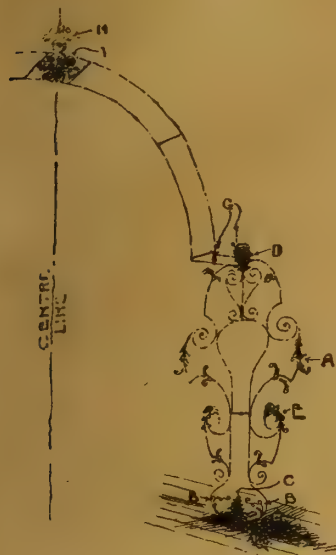

necessities of the case, but giving no apparent strength even to that extent. The details are all of rounded outline, the leaves in particular, which may well be compared with those of the Leversedge screen, of somewhat earlier date, illustrated in the last of this series. As new features, attention may be drawn to the tendril B, and the corkscrew terminals at G and H, which latter are none too securely pinned to the bars which support them.

CHIPS.

In the Court of Bankruptcy on Saturday, a receiving order was made against Mr. Walter Graham, architect, of 12, Buckingham-street, Strand.

The new post-office in Bank-street, Annan, N.B., was formally opened on Saturday. It is built of freestone, and occupies a site of 40ft. by 60ft., being two stories in height.

Mr. Humphrey Lewis, timber merchant, of Conway, died on Friday, aged 55 years. For many years he was partner with the late Mr. Peter Lewis in an extensive timber business at Llanrwst, Conway, and Capel Curig. Mr. Humphrey Lewis had taken a prominent part in public affairs at Conway. He was twenty years a town councillor, and served as mayor two years ago. He was a member of the National school governors, and also of the school board.

Colonel W. B. Slake, R.E., held an inquiry on May 25 at the Shire Hall at Nottingham into the application of the Notts County Council for sanction to borrow £110,000 for the purpose of erecting a lunatic asylum at Radcliffe. Mr. E. P. Hooley, the county surveyor, from whose plans the building will be erected, explained the proposals.

The new Hertfordshire Museum, which is about to be built in Hatfield-road, St Alban's, will be erected from plans by Mr. Arthur S. Flower, F.S.A. A lecture-room and library will form a feature of the institution. The building will be faced with red bricks, red tiles being adopted for roofing, and the heating and ventilation will be on Grundy's system.



LEAF AT  
LOOKING UP.



DETAIL AT G

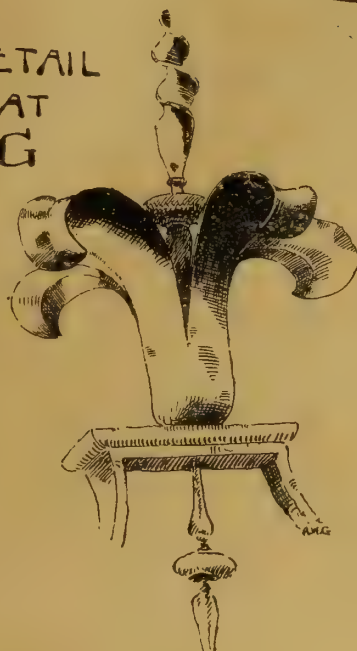

DETAIL AT H



OBITUARY.

Mr. SYDNEY STENT, F.R.I.B.A., M.Inst.C.E., of 43, St. George's-street, Cape Town, died in that capital on May 20, aged 52 years. He joined the Institution of Civil Engineers as an Associate Member in May, 1876, becoming an Ordinary Member seven years later, and he had been a Fellow of the Royal Institute of British Architects since 1880.

WE regret to announce the death of Sir ROBERT RAWLINSON, K.C.B., the distinguished engineer and one of the pioneers of sanitary reform in this country, which occurred at the advanced age of four score and eight years, on Tuesday afternoon at his residence, 11, The Boltons, South Kensington. Born in Bristol on February 28, 1810, he was the son of a mason and builder carrying on business at Chorley in Lancashire, and himself began life as a working stonemason in his father's workshops. One of his first engagements was with Jesse Hartley, the famous engineer of the Liverpool Docks, whose office he entered at the age of 21 as a measurer of masonry. Five years later, in 1836, he entered the service of Robert Stephenson, acting as assistant resident engineer on the Blisworth section of the London and North-Western main line. In 1840, the line being completed, he returned to Liverpool as assistant surveyor to the corporation, and four years later was appointed engineer to the Bridgewater Canal. On the passing of the Public Health Act of 1848, the outcome of the late Sir Edwin Chadwick's inquiries into the sanitary condition of our labouring populations, he was one of the first superintending inspectors appointed. In this capacity he visited and inspected numbers of towns all over the country,

and the reports in which he exposed the overcrowding, the lack of drains and sewers, the absence of a wholesome water supply, and the general want of cleanliness, which he found in only too many places, were often resented by the municipal authorities. Soon after the outbreak of the Crimean War Mr. Rawlinson, Dr. Sutherland, and Dr. H. Gavin were sent out as members of a Sanitary Commission, and were practically given a free hand by the War Office, being instructed to use the utmost expedition in examining into the causes of, and finding remedies for, the unhealthy state of camp and hospital, but were ordered to see, either personally or through their agents, that works considered necessary were immediately begun, and to superintend their progress day by day until they were finished. The commissioners reached Constantinople in the beginning of March, 1855, and set to work on the Levantine hospitals, and from about 42 per cent. in February the death-rate fell to about 2½ at the end of June. In the Crimea, which the commissioners reached in April, similar happy results were soon obtained, simply by attention to limewashing, ventilation, scavenging, and uncontaminated water-supply. While on duty, Mr. Rawlinson had a narrow escape from death, being knocked from his horse by a cannon-ball. In 1863 he worked energetically in Lancashire to organise public works for the starving cotton operatives, and reported that, in his opinion, a million and a half sterling might be expended in permanent improvements of a beneficial character, including main sewerage, drainage, forming and completing streets, making new water-reservoirs, and laying out parks and recreation grounds. In consequence of his statements the Treasury advanced out of the Consolidated Fund a sum not exceeding

£1,200,000 at 3½ per cent., on the security of the local rates, to facilitate the execution of the public works suggested. Under Mr. Rawlinson's direction, success attended the experiment; the men were employed at a wage not less than 12s. a week, while the streets and roads in Lancashire that were at this time sewered, drained, paved, and generally improved, if added end to end would have formed a roadway 400 miles long. In this way £1,850,000 in all were spent, and in recognition of the services he rendered, Mr. Rawlinson was made a C.B. On the constitution of the Local Government Board he became chief engineering inspector, and in 1885, upon retiring from the post, which he had held for 16 years, he was promoted to be K.C.B., having already been knighted in 1883. In addition to his official duties, he acted as Chairman of the Royal Commission on the Pollution of Rivers in 1866, and also served on the Commission which inquired into the sanitary condition of Dublin in 1879. He became an Associate Member of the Institution of Civil Engineers in 1848, and served as president in 1894, and was a vice-president of the Society of Arts. He was for a long period a valued contributor to our columns.

MR. LEOPOLD LOWENSTAM, the well-known etcher, died, after a long and painful illness, on Saturday, at Woodcroft, Three Bridges, Sussex. Born in 1842 at Amsterdam, he studied there at the Academy until 1870, and acquired such a reputation as an etcher that in 1871, at the request of the Swedish Government, he went to Stockholm, and there founded an etching school. In 1873 Lowenstam came to London. He soon made himself known by his etchings of works by Alma Tadema, Rosa Bonheur, Stacey Marks, Boughton, Sadler, Leader, Kilburn, Linton, Sir Edward Poynter, and others, and exhibited for many years at the Royal Academy. He was awarded the highest distinctions and medals at the London, Paris, Amsterdam, Sydney, Melbourne, Columbian, and other exhibitions.

DR. WYNN WESTCOTT, Coroner for St. Luke's, held an inquiry, on Friday, respecting the death of GEORGE HENRY COPE, aged 24, surveyor, lately residing at 78, Cricketfield-road, Clapton. William Courtenay Le Maitre, assistant to the deceased, stated that on Monday afternoon he was with him on the roof of a building at 9A, Hill-street, Finsbury, in the occupation of Messrs. M'Namara, carmen and contractors. The deceased, with a view to alterations, was measuring a chimney stack. In order to do this, he stepped out of the gutter on to the sloping roof, which gave way, and he fell through. Other evidence showed that the deceased fell 15ft. on to the floor of a room, and evidently struck his head on the brickwork of an old disused forge. He died about a quarter of an hour later. Photographs of the roof showed that, although it was apparently sound as viewed from the outside, the rafter had been cut away inside, and the tiles that gave way were supported merely by three battens. At one time a hole had been made in the roof, about 2ft. 6in. square, and this had been merely covered over with tiles instead of being properly repaired. On behalf of Messrs. M'Namara, it was stated that the roof had been in the same condition for the last 20 years, and that they had only had the premises 10 years. Moreover, it was stated that the deceased knew the condition of the roof, as he had been inside the room a few days previously. A verdict of "Accidental Death" was returned.

The new National Schools at Llangedwyn were opened last week. They have been erected from the designs and under the supervision of Mr. W. D. Williams, of the estate office, Llangedwyn, by Mr. R. A. Jones, builder, Llanfyllin. The building is 70ft. by 21ft. 6in., and is designed to accommodate 160 children.

The latest addition to the Bristol tramway system is the extension of the Ashley route, which has now been continued from Sussex-place *via* Lower Ashley-road and Warwick-road to Stapleton-road, where it forms a junction with the Old Market and Staple Hill electric line. The construction of this new section has been delayed by the necessity for first carrying out an important widening of Lower Ashley-road, between Pennywell-road and Seymour-road; but since the acquisition of the properties no time has been lost. The new line, which has been constructed under the supervision of Mr. G. R. C. Edwards, resident engineer, was formally inspected on Friday by Sir Francis Marindin, R.E., the Board of Trade inspecting officer.

## Building Intelligence.

BIRMINGHAM.—Mr. Tart, the manager of the Improvement Scheme, has prepared a set of seven sketch-plans of labourers' dwellings, to be erected upon the Milk-street improvement area. Some time back several tenement dwellings proposed to be erected were opposed by the Health Committee and rejected by the council. A conference has since been held between the Improvement Committee and the Health Committee, formed of four representatives from each body. Mr. Tart's drawings show buildings to be erected in two or three stories, the upper being entered, in some of the designs, from a balcony, and in others by a joint staircase to each pair of houses. The aim of the designer has been to approach as nearly as practicable to letting off two or three rooms, with scullery and other conveniences, at the rate of eighteenpence per room per week. It will not be possible to realise this ideal if anything like the full value is to be allowed for the land. The suggestion is, however, entertained that the rates might bear a portion of the cost of the land as a matter of sanitary improvement. In all the designs 150sq. ft. is allowed as the minimum floor space for a living room and 100ft. for a bedroom.

BRIGHTON.—The new Bible Christian Church in Stamford-avenue was opened a short time since. The building is Early English in style, of semi-cruciform plan, and consists of nave and two wide transepts, and apsidal end. The external walling is of stock bricks with dressings of red bricks and Sussex stone; the roofs are covered with greenish-tinted slates, and are surmounted at the crossing of the transept roofs with an octagonal ventilating turret with oak shingled roof. The window openings are mostly in narrow lancet lights, and are glazed with simple patterns of cathedral glass. The church is placed over the schoolroom; but the gradients have been so utilised as to bring the whole of the windows of the schoolroom above the ground surface; while the external approaches are so arranged as to give access to the church floor level by a rise of only five steps at the east end, and flights of five steps descend to the level of the schoolroom floor at the west end. Internally the walls of the church are finished in plaster, relieved by beads and sunk mouldings. The pews and much of the other woodwork are of pitch-pine. In the rear are a stewards' vestry and a minister's vestry, which are approached by a private staircase, and have also an entrance from the church to the schoolroom. The chapel is seated for 400, and the schoolroom will seat 300, but there are four class-rooms divided off by patent swivel partitions, which can be thrown back, adding space for another 60. The infants' room holds 50 children, and there is also a young women's classroom, accommodating about 30, and kitchen and boiler, sink, and china closet. The heating is by hot-water pipes to the schoolroom and classroom, and by radiators to the church; while the ventilation of the church is provided for by means of exhaust ventilators in the roof, the inlets being arranged by a system of double glazing to portions of the windows, leaving cavities when open in the form of long narrow Tobin tubes. Exhaust shafts are carried up the walls from the schoolroom below. The buildings are lighted with electric light throughout. Mr. E. J. Hamilton, M.S.A., Brighton, was the architect, and Messrs. Saunders and Sons, of Shoreham, were the contractors.

CRAIGMILLAR PARK, EDINBURGH.—The Moderator of the Free Assembly, the Rev. Dr. White, laid last week the memorial-stone of the new Craigmillar Park Free Church, at the end of East Suffolk-road, Edinburgh. The plans have been prepared by Messrs. Sydney Mitchell and Wilson, architects, 13, Young-street, Edinburgh. The church is cruciform, and consists of a nave, aisles, transepts, and a semi-octagonal apse. The tower is in the north-west corner, and in it the main entrance is placed. Over the vestibule between the doorway and the church is placed a western gallery. The nave is divided into three bays by circular columns with moulded capitals, and these carry obliquely-pointed arches. The clerestory windows, of which there is one over each bay, are of three lights, filled with cusped tracery. There are no windows in the aisles themselves in order that they may be in shadow, and thus increase the effect of the ample light in the church itself. The aisles are used entirely

as passages, and contain no seats. The apse is separated from the church by a lofty stone arch, and is lighted by three tall and narrow windows with traceried heads. A high panelled dado is carried round the apse, and its floor, which is raised three steps, is laid with encaustic tiles. The pulpit, which is of wood, is placed at one side of the arch between the church and the apse, and the Communion-table, reading-desk, and font are placed in the apse itself. On the north side of the apse, and opening into both it and the north transept by means of stone arches, is the organ-chamber. The roof of the apse is treated as a semi-dome, and is lined with wood and decorated with moulded ribs of the same material. The roof of the nave and transepts is open-timbered. Behind the church, vestry, session-house, ladies' room, &c., are provided. The hall is unusual in shape, being a complete octagon, with a row of low, many-mullioned windows on each of its sides. The tower is square in plan, and is designed without buttresses. At the belfry stage the walls are set back, and an octagonal turret with a pyramidal top is formed at each angle; between these is a panelled parapet, and above this parapet the tower changes from square to octagonal, and finishes with a stone spire. The church is seated for over 700, and the hall for nearly 300.

DURHAM.—The new County Council buildings in Old Elvet are approaching completion. They are being built from designs by Messrs. Harry Barnes and Frederick E. Coates, of Sunderland and Hartlepool, selected in competition. The front elevation is of red terracotta, and the sides and back are of brick, with buff terracotta dressings. The buildings have a frontage of about 170ft. and a depth of 150ft. In the centre is a large tower with dome, which is the chief feature of the elevation. It is carried on plaster columns, and covered with copper. The building is roofed with green slates. A flight of steps some 40ft. in width leads up to the front entrance, which is through an arched doorway, and minor entrances are placed at the sides. The ground floor is occupied by the council chamber, the committee rooms, offices of the clerk to the County Council, and the reception rooms. The chamber is approached through an anteroom of hexagonal form, 32ft. wide by 33ft. high. The council chamber, which is horseshoe in shape in its lower half, makes the transition to the circular at a height of about 12ft. The diameter is 45ft., and the height 36ft. It is crossed by four arches of 28ft. span, carrying the dome. The walls of the chamber are pierced by several windows of stained glass, and polished marble columns surround the chamber. The committee room is 42ft. by 21ft. From the ground floor access to the floor above is gained by a flight of stairs. The steps originally intended to be of tinted green slates are being constructed of marble. On the floor above are to be the offices of the county surveyor, the county accountant, the county medical officer, and the County Education Department. Above these again are a number of spacious rooms for laboratories, libraries, &c. The basement of the building, in addition to offices for the weights and measures department, contains strong rooms, store rooms, &c., and is entered from the street level; along the corridor of the ground floor runs a dado of faience work. The marble work is being executed by Messrs. Lowes and Sons, Durham, and Messrs. Burmantofts, of Leeds, have been doing the faience work. Furniture is being supplied by Messrs. Robson and Son, Newcastle. Messrs. Rule, Sunderland, have done the plaster-work, and Messrs. McCulloch, of Glasgow, have furnished the stained glass windows. The heating apparatus is supplied by Messrs. Ashwell and Nesbitt, of Leicester. Messrs. Rankin and Son, Sunderland, are the sole contractors for building. The entire cost will be about £29,000, including the purchase of land and furniture.

MARYLEBONE.—The new central administrative department of the Marylebone Workhouse has been opened by the Bishop of London. The new building, which has just been completed at a cost of £50,000, stands upon the site of the original administrative blocks and chapel, which were pulled down in the latter part of the year 1896. It is designed to concentrate in one block the whole of the administrative offices (except the laundry) of the workhouse, and such parts as are used in common by all the inmates. The new general dining-hall is capable of seating 1,000 inmates at meals. The walls are faced with glazed bricks, relieved by a dark dado and

coloured bands, and the roof is of open timber, and the lofty walls are treated in panels, decorated in stencilled colour. The tables are so constructed that they can be folded so as to form comfortable backs to the seats when the hall is used for entertainments. Adjoining the dining-hall is the general kitchen, which is fitted with steam and gas apparatus for cooking for as many as 2,000 people at one time. The chapel is seated to hold 550 people. The dining-hall is heated with steam coils, and all other rooms are fitted with open fires, while the whole building is lighted throughout by electricity, gas also being provided at certain points. The buildings have been erected from the designs of Mr. A. Saxon Saell, F.R.I.B.A., by Mr. Charles Wall. An additional block will be erected on the Marylebone-road side of the workhouse, at a further cost of £60,000.

**NEWCASTLE-ON-TYNE.**—The opening services of the reconstructed Erskine Presbyterian Church, in Rye Hill, Newcastle, took place on Friday. The church has been rebuilt on the site originally occupied by the old church, in accordance with plans prepared by Messrs. Badenoch and Bruce, and it will now accommodate 500 worshippers, whereas only 300 could be accommodated in the old church. The building is designed in Late Gothic style, with walls of rubble, faced on the Rye Hill side by sneaked stone facings, with chiselled stone dressings. At the entrances two large porches project into the open space in front, giving access to vestibules and staircases leading to galleries which run round three sides of the building. The roof is constructed with hammer-beam trusses in pitch pine, with cleaded ceilings following the line of rafters and collars, and divided into panels with mouldings planted on. The old schoolroom in the basement has not been interfered with, though the front portion under the vestibules has been converted into a ladies' room and tea-room with wide vestibule, and entrance lobby and lavatories. Mr. Robt. Veitch, of Barrack-road, Newcastle, has been the contractor. The heating will be effected by low-pressure hot-water pipes and radiators. The ventilation is by Causland and Mackay's climax roof ventilators, and the building will throughout be lighted with electricity.—The foundation-stone of the Primitive Methodist central church in Northumberland-road, Newcastle-on-Tyne, was laid on Monday. The church, which cost about £12,200, is planned to seat about 800 worshippers—for the most part on the ground floor—with a wide horseshoe-shaped gallery round three sides of the church. Behind the rostrum is the choir gallery and organ chamber. The entrance lobbies, vestibules, and staircases are spacious, and cloakrooms are provided at the entrances. Special additional exits are provided, so that a large congregation can leave the building in the shortest possible time. The school buildings and vestries will be connected with the church at the rear, and will have a frontage to Ridley-place—there will be lecture hall, galleried schoolroom, church parlour, library, minister's vestry, and classroom, together with a caretaker's house. It is intended to light the whole of the buildings by electricity. The church will be built of stone, with Westmoreland green slate roof. The windows will be glazed with cathedral glass in leaded squares. The internal fittings will be of varnished pitch-pine. The architects are Messrs. Davidson and Bende, and the contractor was Mr. A. Bruce, all of Newcastle.

**OLDSWINFORD.**—On Saturday, May 2nd, the church of St. Mary's, Oldswinford, whose foundation dates back to the 13th century, was reopened, when the Bishop of Worcester consecrated the new chancel, which has been erected from designs of Mr. J. A. Chatwin, of Birmingham, at a cost of upwards of £3,500. The original church was taken down, with the exception of the tower and spire, nearly sixty years ago, and an unsightly, oblong galleried building with a one-span roof, carried on weak-looking principals, replaced it. The chancel now added is about 40ft. long by 22ft. wide, with a chancel aisle on the south side, and has vestries and a spacious organ-chamber on the north. An arch now divides the nave from the chancel, the roof of which is wagon-headed. In the east wall there is a large window. The style is that of the Decorated period. Beneath the vestries has been provided a room, capable of receiving organ-bellows and a gas-engine. The chancel is faced externally with red Bromsgrove stone, and

inside the dressings are of Bath stone. The gain in space by the present alterations will altogether give accommodation for about one hundred more worshippers. It is hoped at a future day to form a nave of the same width as the chancel by erecting two arcades of four arches each. The roof of the nave would then be made to correspond somewhat with the chancel, and the north and south aisles would have a span roof. The present stone walls and windows on the north and south sides of the church would remain. Messrs. Collins and Godfrey, of Tewkesbury, were the builders. The cost was £3,800.

**PETERBOROUGH CATHEDRAL.**—During the past fortnight much progress has been made under the superintendence of Mr. J. T. Irvine, the architects' clerk of works, in the bottoming of the north-eastern corner of the eastern chapel of Peterborough Cathedral which has so long been failing. The subsidence has threatened the destruction of the beautiful structure with its magnificent fan tracery. It was the last work added to the monastery church before the Reformation. It was built by Abbott Richard Ashton, circa 1438. The work was not finished before the death of Kirkton in 1528. During the work of excavation the workmen came across a mass of tooled stone—tracery of windows, and such like, which had evidently belonged to the Lady-chapel, pulled down to save repairing in 1670. Evidently, after the dean and chapter returned, the weakness of this eastern building was most apparent, and as the ruins of the Lady-chapel were plentifully in evidence, they dug a grip around the failing foundations of the eastern chapel, and pitched the stone in, with an erroneous idea that it would strengthen the foundations. There was no attempt at all of laying the fragments in any sort of order, and thus they have now been found 300 years later. A discovery of the Saxon wall of the ancient monastery has been made. This is one of the most important finds—next to the Saxon church and the Saxon cemetery—of the whole restoration, now extending over a period of over fifteen years. The eastern wall of the chapel has been found to be partially built upon it, and it is this Saxon wall which has sunk and carried with it the foundations of the eastern chapel.

**SHAW, LANCs.**—A new Congregational school adjoining the chapel in Rochdale-road, Shaw, was opened on Saturday last. On the ground floor are five classrooms, infants' room, 21ft. by 17ft., young men's room, 36ft. by 17ft., and young women's room, 26ft. by 15ft. All the first floor is appropriated by the assembly-hall, which is approached by wide staircases; its dimensions are 68ft. by 36ft., and seats 500 people. A platform, with ante-room attached, is provided at one end of the hall. The heating-chamber, kitchen, &c., are in the basement, under the rear of the building. The front is faced with Hipperholme pitch-faced wallstone, with dressings from the same quarries, the sides and back being faced with Accrington bricks and Yorkshire stone dressings. All the joiners' work inside is of pitch-pine. Mr. Whitworth Whittaker, of Oldham, was the general contractor. The sub-contractors were: Masonry, Mr. J. Bryan Shaw; carpenter and joiners' work, Mr. Booth Smith, Oldham; plumbing, &c., Mr. J. Broadbent, Shaw; plastering, Mr. D. Eastwood, Oldham; slating, Mr. J. Pogson, Shaw; heating, Mr. I. Butterworth, Rochdale. The architect was Mr. F. W. Dixon, Oldham.

Lord Courtenay, heir to the earldom of Devon, and for many years a Local Government Board inspector in the West of England, died yesterday in his 63rd year.

On Thursday in last week, Colonel C. H. Luard, R.E., an inspector of the Local Government Board, held an inquiry into the application of the Southborough Urban District Council for sanction to borrow £2,500 for works of street improvement, and £2,000 for the erection of a public hall.

At the town-hall, Evesham, on Friday night, nearly 200 workpeople engaged on the extensive alterations and building at Wood Norton were entertained to a "rearing supper" by the Duke of Orleans. The work has been proceeding for nearly a year, and it is hoped it will be finished in August, after which the Duke and Duchess of Orleans are expected to be frequent residents at their Worcestershire estate. The contractors are Messrs. Collins and Godfrey, of Tewkesbury, and both were present at the supper, Mr. Collins presiding. Others present were Messrs. C. H. Smith (agent to the Duke of Orleans) and G. H. Hunt, the architect.

## Engineering Notes.

**RAILWAY THROUGH SAVERNAKE FOREST.**—Messrs. John Aird and Co. have just completed a railway which runs through the southern portion of the forest at Savernake, in Wiltshire. The line has been constructed at the instance of the Midland and South-Western Junction Company, who seventeen years since opened the Swindon, Marlborough, and Andover Railway connecting the Great Western system at Swindon Junction on the one side with the South-Western system at Andover Junction on the other, thus leaving Marlborough and other places en route, besides establishing a direct north and south route between the manufacturing districts and Southampton and Portsmouth. Hitherto the company has had to contend with difficulty, delay, and expense by running over five and a half miles of the branch from Marlborough to the Savernake Junction of the Great Western Railway, and it is with the view of obviating these obstacles that the new line has been constructed.

### CHIPS.

A new organ, built by Mr. J. J. Binns, of Bramley, has just been placed in St. Wilfred's Church, Kirkby Knowle.

The new workhouse infirmary at Leek was formally opened on Wednesday week. It accommodates 60 beds, and has cost £103 per patient. Mr. J. T. Brealey was the architect, and Mr. E. R. Meldrum the clerk of works.

Major-General H. Darley Crozier, R.E., inspector to the Local Government Board, held an inquiry at the union offices, Bury, Lancs, on Thursday in last week, into the application of the Bury Rural District Council for sanction to borrow £1,200 for works of sewerage for the village of Walshaw, in the township of Tottington-lower-end. The scheme was drawn up by Mr. Joseph Olive, surveyor to the rural council.

Mr. Anning Bell, whose work in the field of decorative design, no less than in that of sculpture, has given tone to the art side of University College, Liverpool, is succeeded by Mr. J. Herbert M'Mair in the conduct of the classes in design at that college. Mr. M'Mair has a reputation as a colourist, and has executed a good deal of work in the form of water-colour and pastel drawings and mural decoration, as well as stained-glass and other branches of applied art.

The Court of Common Council have resolved to abandon its scheme for effecting a great public improvement on the site of the great fire in Cripplegate, owing to the County Council having declined to assist in the matter except upon impracticable conditions.

As a memorial of the Queen's Diamond Jubilee, a stained-glass window has been placed in the parish church of Silverdale, Staffs, and it was dedicated by the Archdeacon of Stoke on Wednesday week. The window was designed and erected by Messrs. Heaton, Butler, and Bayne, of London. It is divided into two panels, and the subjects are the Queen of Sheba and Queen Esther. Below these are the dates 1837 and 1897.

The rural district council of the Isle of Thanet have at length decided that Birchington-on-Sea shall be provided with an efficient system of sewerage, and have instructed Messrs. Bailey-Denton, Son, and Lawford, of Westminster, to report in detail thereon.

A convention of the American Institute of Architects will be held at Washington, D.C., from Nov. 1st to 3rd. The headquarters will be at the Arlington, and the following speakers have been secured to address the convention:—Mr. B. E. Fernow, Chief of the Division of Forestry, of the Agricultural Department; Mr. Merrill, on Building Stones; Mr. Adler, of the Smithsonian Institute, on the place to be assigned to the Jewish people in Architectural History; and Professor Sabine, of Harvard, on Acoustics.

The dredging operations which have been going on for some time past for deepening Jersey Harbour, have now been completed. A channel has been made from the outside roads to inside the mouth of the harbour, having an average depth of 11ft. at low water; also a depth of 9ft. at the railway companies' berths. The work has been done by Messrs. Volker and Bos, of Holland. Over 350,000 cubic yards of sand, blue clay, stones, and silt have been removed.

Wetherby guardians and rural district council have appointed Mr. Silcocks, borough engineer and surveyor, of King's Lynn, who will shortly commence private practice in Leeds, to prepare a scheme of sewerage and sewage disposal for Shadwell.

## COMPETITIONS.

GLASGOW INTERNATIONAL EXHIBITION, 1901.—In connection with the competitive plans to be submitted by architects for the Glasgow International Exhibition in 1901, it has been decided by the Building Committee to recommend to the Executive Council that the following professional members of the Building Committee, together with the convener and vice-convener, be appointed a sub-committee to examine the plans when received and to report:—Messrs. J. J. Burnet, A.R.S.; W. Leiper, R.S.A.; A. B. McDonald, C.E.; W. F. Salmon, James Thomson, and Robert Whitson.

LEEDS.—The Corporate Property Committee of the Leeds Corporation had before them at their last meeting the designs submitted under the motto "White Rose" for the redecorating and refurbishing of the Lord Mayor's rooms at the Town-hall, to which the first premium was awarded as the best designs. Messrs. Marsh, Jones, and Cribb, of Leeds, were the successful competitors, and the committee propose to use their designs as the basis for the work, which, it is expected, will cost about £1,500.

TROWBRIDGE.—The assessor's award in the competitive designs for new schools is expected on June 8. The whole of the designs sent in will be on view at the Town Hall, Trowbridge, on Thursday, Friday, and Saturday, June 9, 10, and 11, from 10 a. m. till 8 p. m. each day. The designs to be returned will be sent to their respective authors after the close of the public exhibition.

WOLVERHAMPTON.—At the meeting of the board of guardians on Friday, a discussion took place upon a report presented by the New Workhouse Committee, with regard to the selection of architects to submit plans for approval. It was recommended that the competition be limited to all architects having offices in the Wolverhampton union, and Messrs. Magnall and Littlewoods, of Manchester, Mr. W. Doubleday, of Birmingham, and Messrs. Marshall and Turner, of Nottingham, and that the author or authors of the designs selected by the guardians as most useful have the appointment of architect, at the usual fee of five per cent. upon the outlay, to include all fees and expenses, and that a fee of £200 be paid to the author of the second best design, and £100 to the third author of merit. An amendment that the competition be limited to three local gentlemen and the three outside architects was agreed to; and, on a vote being taken—twelve local architects being nominated—the following obtained the highest number of votes:—Messrs. Beck, Berrington, and Johnson. It was then decided that £100 be given to the architects sending in the second, third, and fourth best designs.

The board of the Jura-Simplon Railway has ratified the contract with Messrs. Brandt, Brandau, and Co., for the construction of the Simplon Tunnel, and has also approved the loan agreement with the Cantonal Banks Syndicate.

Mr. H. P. Baulnois, a Local Government Board inspector, attended at the Urban Council Room, Wellington, Salop, on May 25, to take evidence in respect to an application from the urban council for sanction to borrow £500 for an improvement at the corner of New-street.

A south aisle, seating 100 persons, and sacristy and side chapel have been added to St. Stephen's Church, Devonport. Messrs. Pethick Brothers, of Plymouth, were the contractors, and the outlay has been about £3,000.

On Thursday in last week the Very Rev. Canon Douglass blessed the new church dedicated to St. Peter, which has been erected in Church-lane, adjacent to the Board schools, Beeston, Nottingham. The building is from the designs of Messrs. Hart, of Corby, and has cost £600. The structure, which will accommodate 150 persons, and which stands on 800 square yards of ground, is of red brick, with stone dressings. Ground is secured for future extension, and also for a priest's house, which will be erected at the earliest opportunity.

At the Free Methodist Sunday-school at Grantham the trustees have been obliged to provide additional accommodation, and recently they acquired a disused malting adjoining the chapel. At a cost of about £300 this has been converted into a school-room and lecture-hall, which will seat about 250 persons. The front of the hall has been faced with bricks and stones, the style being in harmony with the facade of the chapel. The work was carried out by Messrs. Wartnaby and Sons, the plans being prepared by Mr. J. W. Taylor, who also supervised the alterations.

## TO CORRESPONDENTS.

[We do not hold ourselves responsible for the opinions of our correspondents. All communications should be drawn up as briefly as possible, as there are many claimants upon the space allotted to correspondents.]

It is particularly requested that all drawings and all communications respecting illustrations or literary matter should be addressed to the EDITOR of the BUILDING NEWS, 332, Strand, W.C., and not to members of the staff by name. Delay is not unfrequently otherwise caused. All drawings and other communications are sent at contributors' risks, and the Editor will not undertake to pay for, or be liable for, unsought contributions.

Cheques and Post-office Orders to be made payable to THE STRAND NEWSPAPER COMPANY, LIMITED.

## TERMS OF SUBSCRIPTION.

One Pound per annum (post free) to any part of the United Kingdom; for Canada, Nova Scotia, and the United States, £1 6s. 0d. (or 6dols. 30c. gold). To France or Belgium, £1 6s. 0d. (or 33fr. 80c.). To India, £1 6s. 0d. To any of the Australian Colonies or New Zealand, to the Cape, the West Indies, or Natal, £1 6s. 0d.

## ADVERTISEMENT CHARGES.

The charge for Competition and Contract Advertisements, Public Companies, and all official advertisements is 1s. per line of Eight words, the first line counting as two, the minimum charge being 5s. for four lines.

The charge for Auctions, Land Sales, and Miscellaneous and Trade Advertisements (except Situation advertisements) is 6d. per line of Eight words (the first line counting as two), the minimum charge being 4s. 6d. for 40 words. Special terms for series of more than six insertions can be ascertained on application to the Publisher.

Front-page Advertisements 2s. per line, and Paragraph Advertisements 1s. per line. No Front-page or Paragraph Advertisement inserted for less than 5s.

Advertisements for the current week must reach the office not later than 3 p. m. on Thursday. Front-page Advertisements and alterations in serial advertisements must reach the office by Tuesday morning to secure insertion.

## SITUATIONS.

The charge for advertisements for "Situations Vacant" or "Situations Wanted" is ONE SHILLING FOR TWENTY-FOUR WORDS, and Sixpence for every eight words after. All Situation Advertisements must be prepaid.

## NOTICE.

Bound copies of Vol. LXXXIII. are now ready, and should be ordered early (price Twelve Shillings each), as only a limited number are done up. A few bound volumes of Vols. XXXIX., XL., XLI., XLII., XLIII., XLIV., XLV., XLVI., XLVII., XLVIII., XLIX., L., LI., LIV., LVII., LX., LXI., LXII., LXIII., LXIV., LXV., LXVI., LXVII., LXVIII., LXIX., LXX., LXXI., LXXII., may still be had, price Twelve Shillings; all the other bound volumes are out of print. Most of the back numbers of former volumes are, however, to be had singly. Subscribers requiring any back numbers to complete volume just ended should order at once, as many of them soon run out of print.

RECEIVED.—W. M.—A. W. and Son.—V. D.—N. B.—W. M.—H. R.—W. B. C. H.—H. C.

## Correspondence.

## THE ARCHITECTURAL ASSOCIATION.

To the Editor of the BUILDING NEWS.

SIR,—Although a goodly number attended the annual dinner on May 26, it must have been evident that the old fairs were wanting. We looked in vain for Messrs. T. Blashill, J. D. Mathews, J. Slater, Cole Adams, J. A. Gotch, L. Stokes, E. W. Mountford, G. H. Birch, S. Flint Clarkson, and many others.

Of the old lot we found only Messrs. H. Tanner, J. Osborne Smith, and H. Lovegrove, with some more modern friends of the A.A., such as Messrs. Caröe, B. Pite, W. Pite, B. F. Fletcher, and Seth-Smith.

Is it that the change of method has made the older men feel that things are not what they were, and that the old A.A. is fast passing away from the old mutual help society into a teaching branch of the R.I.B.A.?

The improved methods of teaching we all approve of; but the loss of the former friendliness would be very deplorable.—I am, &c.,

OBSERVER.

Adjudications in bankruptcy have been made in the cases of Joseph Brown, North-road, Croydon, and of George James Chivers, Myddelton-square, Islington, and Hornsey-road, Holloway, also a builder.

The town council of Truro having applied to the Local Government Board for sanction to borrow £1,250 for works of paving, Mr. W. A. Ducat, Local Government Board inspector, attended at the Town-hall of that city on May 25 to hold an inquiry. The borough surveyor, Mr. W. C. Clemens, gave details of the proposed expenditure.

## Intercommunication.

## QUESTIONS.

[1961].—Parliament Street.—Would Mr. Hebb, or any of your correspondents acquainted with the history of modern London, give the date of the actual formation of Parliament-street from Whitehall through the Board of Trade's old offices, which were, previous to this improvement, located in the house formerly belonging to the Earl of Rochester? Parliament-street cut right through the side of the Privy Garden and into Rhenish Wine-yard, Stephen's-alley, White Horse-yard, Clinker's-court, and Wool Staple into New Palace-yard. Great George-street absorbed Bell-alley, George Inn-yard, and Blue Boar's Head inn-yard. I cannot find an exact reference as to the precise date when this improvement was carried out. Can any reader oblige?—MONTROSE.

## REPLIES.

[1957].—Breweries.—There is a very good book named "Breweries and Maltings," by Mr. G. Scammell, and I think that some articles appeared in the "B.N." some years since.—H. L.

[1958].—Stone Lintels and Architraves.—I should advise "Young Architect" to have the lintel in one piece, as any joint except a visible joggle joint would not look well, and the joint is ordinary.—H. L.

[1959].—Fixing Columns.—It would be better to bond the three-quarter columns and to dowel the frustum.—H. L.

[1960].—External Wall.—This is not very clearly put, as it appears that B. intends to build a separate external wall, so how can the wall of A. be a party-wall, which is defined as a wall separating two buildings? If B. intends to raise on the party-wall he must give the usual notice; but if he simply intends to build an adjoining wall, he need not give notice unless he intends to make his footings deeper than A.'s wall, when he must arrange to underpin.—HENRY LOVEGROVE.

## CHIPS.

Considerable additions are being made to Farnham Union, and special consideration has been given to the ventilation, which will be carried out on the Boyle system.

In the case of John Dewhurst, North End-road, West Kensington, W., electrician, sanitary engineer, and plumber, the discharge from bankruptcy has been suspended.

The urban district council of Twickenham have under consideration the desirability of purchasing for preservation as a public park the riverside Peel Estate at Marble-hill, which for eight or nine years past has been in the market. The estate comprises 63 acres of well wooded land and a house.

The new underground telegraph cable from London to Birmingham is on the point of completion.

Before Sheriff Rutherford and a jury in Edinburgh Sheriff Court on Friday, an elderly man of respectable appearance, William Darlington, residing at Easter Duddington, was sentenced to nine months' hard labour on four charges of fraud. The accused had formed a fraudulent scheme of obtaining goods on false pretences by means of letters and post-cards, upon which it was represented that he was a surveyor and required the goods for the purposes of his business. The firms defrauded were: The Decorative Art Tile Company, Ltd., Hanley; Francis Carter, a stationer, Derby; Waterproofing Varnish and Wall Decoration Company, Ltd., Barhead; and Moore and Co., tile and glass painters, at Lancaster.

Colonel Albert C. Smith, R.E., an inspector from the Local Government Board, held a public inquiry at Weybridge, on the 26th ult., into the application of the urban district council for sanction to borrow £2,500 for works of surface-water drainage, and £2,500 for the improvement of footpaths. The plans were prepared by Mr. J. S. Crawshaw, surveyor to the council. The surface drainage system comprises a new outfall constructed of 18in. stone-ware pipes.

At the last meeting of the City Court of Common Council, a report was brought up from the Streets Committee as to the artesian well experimentally sunk in the Petticoat-square site of the model lodging-houses erected by the Corporation, with the view of rendering the tenants independent of the New River Company. They recommended that no further action should be taken in regard to utilising the surplus water from the well, owing to the expense and the insufficiency of the surplus supply for street washing, fire extinction, and other purposes. The report was adopted.

The need of additional accommodation at the Falmouth Hotel for sitting-rooms and suite of rooms has compelled the directors to enlarge the hotel towards the west, and the foundation-stone of the new wing which is to be added was on Thursday in last week laid by Sir Joseph Fayer. The addition will consist of 80 new rooms, including a coffee-room, facing south and west, and seating over 100 persons. A service-room, kitchen, and scullery will also be added.

CONTENTS.

Negligence in Building .....	767
Model Specifications.—XV. ....	767
The Architectural Association Dinner .....	769
The Society of Architects .....	770
A Case of Jurisprudence in Land Surveying .....	770
Professor Banister Fletcher .....	771
Art Metal Exhibition at the Royal Aquarium .....	771
Foundations as Applied to London Buildings and .....	772
Riverside Foundations .....	772
Drawings by Charles Keene .....	774
Ironwork at South Kensington Museum.—IV. ....	775
Obituary .....	775
Building Intelligence .....	776
Engineering Notes .....	777
Competitions .....	777
Correspondence .....	778
Intercommunication .....	778
The BUILDING NEWS Directory .....	IX.
Our Illustrations .....	779
Legal Intelligence .....	798
Professional and Trade Societies .....	799
Our Office Table .....	799
Meetings for the Ensuing Week .....	800
Trade News .....	800
Latest Prices .....	801
List of Competitions Open .....	802
List of Tenders Open .....	802
Tenders .....	803

ILLUSTRATIONS.

- NUNEATON CONSERVATIVE CLUB.—ROCHDALE COTTAGE HOMES.—HOUSE AT SHACKLEFORD.—FIREPLACE IN BOLSOVER CASTLE.—HOUSE AT THORPE MANDEVILLE.—DETAIL OF DUTCH SEVENTEENTH-CENTURY CABINET.—ALTRINCHAM TOWN HALL.

Our Illustrations.

NUNEATON NEW CONSERVATIVE CLUB.

THE new Conservative Club premises at Nuneaton shown on this illustration are being built. The contractor is Mr. T. Smith, of Chilvers Coton, Nuneaton. The club is to occupy the corner site formed by New Bridge-street and Bondgate. Four floors of the building are to be devoted to the use of the members. In the basement a double skittle-alley occupies the side of site next right-of-way, the remainder of this floor being occupied with beer and wine cellars, heating cellar, and coal store. On the ground floor (which is raised 3ft. above the general street level for the better lighting of the basement), are situated the ordinary members' billiard-room (for two tables) coffee, reading, and smoke rooms, bar, lavatories, secretary's office, and entrances, the principal being from the angle and a side entrance from New Bridge-street. A spacious arched entrance-hall contains the wide, open staircase leading to the upper floors. On the first floor, of primary importance is the assembly-hall, to accommodate 500, with gallery at one end, entered off landing of upperstairs. The ceiling of hall is proposed to be a third of the way down from ridge, giving as great cubic contents as are consistent with acoustic requirements. The wood trusses, which are of the hammer-beam type, with moulded ribs, show beneath the ceiling, and spring from stone corbels of moulded section. Retiring and ante-rooms, with their attendants' offices, are conveniently situated and easily accessible from hall. A separate staircase, leading from side entrance to hall, enables the latter to be used without any inconvenience to the other users of the club premises. The ante-room, being situated at the angle of the streets, a glazed door opens on to a speech-gallery or balcony contrived over the front entrance. The other apartment which completes the first floor, is a spacious committee-room on the New Bridge-street side, with open loggia the extent of its front, having hammered iron ornamental balconettes. The second floor contains the honorary members' billiard-room, with ante-room and lavatory running the whole length of New Bridge-street front. By the formation of the roof, accommodation has been provided for a caretaker in same; the kitchen with its attendant offices also being here placed, a lift could be conveniently arranged from the kitchen to the ground floor with intermediate services to the principal rooms on the first and second floors. The building will be heated by hot water on the low-pressure system, and lit by electricity. The materials are red brick, with Bath stone dressings, roof covered with Carnarvon slates, all woodwork internally to be of deal stained dark green; the windows filled with iron casements and leaded lights to open as required for ventilation. The entrance-hall floor is to be laid with terrazzo, the corridor tiles, the basement cement, and the remaining floors wood; that over

honorary members' billiard-room will be made soundproof by silicate cotton packing, so that no noise can be transmitted from caretaker's apartments. The roofing will be rendered damp-proof by a layer of under-slating. The building is designed as a Free Classic treatment, a feature being made of the angle, which is boldly relieved by the speech balcony over doorway, and, further, by culminating in an octagon at the top, with pointed roof, forming a base for flagpole. The assembly-hall has been taken advantage of to form the feature in the Bondgate elevation, a semicircular glazed tympanum accentuating the three central lights of the window, and the gable formed producing the desired balancing effect. The New Bridge-street elevation has some relief imparted to it by the committee-room loggia, with its stone arches and columns, and the airy, curved wrought-iron work avoids a tendency to overpowering effect. The architect is Mr. Charles William Smith, M.S.A., Grantham, whose plans were selected in the recent competition, and the work is now in hand.

COTTAGE HOMES, MIDDLEWOOD, FOR THE ROCHDALE UNION.

THESE homes are to be erected in a hilly district, away from, and out of sight of, the workhouse. The present scheme is for a receiving-home at the entrance to accommodate twelve children, with two spare bedrooms, a superintendent's house, offices, and stores; the house also to accommodate six of the older girls, eight semi-detached homes for boys and girls, each providing for twelve children, with an additional spare bedroom each. Instead of building a hospital, two spare houses are shown similar in plan to the receiving-home, but only one of these is let in the present contract; the workshop shown at the back of the view is also deferred for the present. Each home contains living-room, playroom, kitchen, scullery, bathroom, and the necessary pantries and larders; the ground floor and the upper floor are each divided into two bedrooms for children—one spare bedroom and mothers' bedroom. The ground floors will be mainly laid with wood blocks; the buildings are to be built in Yorkshire pitch-faced parpoints, the gables finished in Parian cement, the chimneys in Ruabon bricks, and the roofs covered with Westmoreland green slates. The number of beds provided in the present scheme, including mothers', is 143, and, as the contract has been let to Messrs. Preston and Dryland, of Littleborough, at the sum of £12,600, this works out at less than £90 per bed. The architects are Messrs. P. Butterworth and Duncan, of South-parade, Rochdale, who are also engaged on plans of a new hospital for over 300 beds for the guardians of the same Union.

HOUSE AT SHACKLEFORD, SURREY.

THIS house is much more extensive than the last, and it is also designed by Mr. Voysey, who says of them both: "They are only intended for 19th-century homes, and have no architectural growth of anatomical interest." Failing further particulars, we are unable to give the usual information; but, after all, it is the somewhat unusual quaintness of their odd picturesqueness which gives these designs by Mr. Voysey their individuality. This is the residence of the Rev. Leighton Crane. The plans add much to the interest of the plate.

BOLSOVER CASTLE FIREPLACES: NATIONAL SILVER MEDAL DRAWINGS.

IN the BUILDING NEWS for April 15 last we gave a double-page plate, reproduced from Mr. A. B. Illston's measured details of these interesting Jacobean or Renaissance chimney-pieces, for which Bolsover Castle is so justly famous. Today we print another example, one of the best of the series. A rather full description of the building, giving an outline of its history, was given on the occasion when we published the first drawing as above-mentioned; consequently there is nothing to add here to-day. A National Silver Medal was awarded to Mr. Illston for this set of drawings. One more remains to be illustrated, and that will appear shortly—so soon as space will permit.

HOUSE AT THORPE MANDEVILLE, NORTHANTS.

THE drawing which illustrates this house is in the Royal Academy Exhibition. The plan explains the internal arrangements of the building, and the simplicity of the exterior forms its characteristic. Oak, left its natural surface, and white-wash are the inside colours employed. Outside,

rough-cast and green slates are the materials depended on for effect, with red pots for the chimneys. Mr. C. F. A. Voysey is the architect.

DETAIL OF DUTCH SEVENTEENTH-CENTURY CABINET.

THIS old piece of solidly-constructed Renaissance furniture has been drawn out by Mr. C. Kemp Bonnar, of Edinburgh, whose details are so clear as to need no description. Sketches in perspective of historic pieces of this kind are interesting enough; but the practical cabinet-maker wants the actuality technically displayed—hence the usefulness of such illustrations as this. The small elevations show the cabinet as a whole. Much of its quaintness depends upon the angle-way set columns on either side. The carving of the piece is reduced to a minimum in quantity.

ALTRINCHAM TOWN HALL.

THIS design was submitted in an open competition. The sum available was £4,000, which was to include a fire-station and caretaker's house. The public offices are situated on the ground-floor, the council chamber, &c., on the first floor. The council chamber is indicated on the exterior by a long range of windows, flanked by angle turrets. The materials to be of pressed brick, with stone dressings, and green slates on the roof. The author of the design is Mr. F. W. Mee, architect.

CHIPS.

The Goldsmiths' Company have made a grant of £600 to the building fund of the North-Eastern Hospital for Children, Hackney-road, Shoreditch, which is about to be completed after remaining unfinished since 1880.

The repairs to the spire and tower of Salisbury Cathedral have been completed from Sir Arthur Blomfield's plans, and £14,000 has been expended, the whole sum having been subscribed except £600. There is to be a thanksgiving sermon in the cathedral on Monday, July 11, when the sermon will be preached by the Archbishop of Canterbury.

The restoration of the 17th-century town house of Lady Stair in the Lawn Market, Edinburgh, has just been completed from plans by Mr. G. S. Aitken, of Queen-street, Edinburgh, for Lord Rosebery. The house was built in 1622 by Sir William Gray, of Pettendrum.

To the collection of pictures in the Museum at Peel Park, Salford, there has just been added "A Spanish Sheep-stealer," by the late W. Bright Morris.

The new suburban station about a mile and a half from Bristol on the Great Western, which is known as St. Anne's Park, was opened last week. It has been built at a cost of £4,000, and the adjoining district is being laid out for small villas.

Princess Christian has consented to open the new girls' school of the Stepney and Bow Foundation, now being erected in the Bow-road, on Thursday next, the 9th inst., at three o'clock.

Cardinal Vaughan has laid the foundation-stone of a Roman Catholic church, to be dedicated to SS. Peter and Paul, in High-street, Ilford. The church is designed with nave and side aisles, two chapels, and sanctuary, to seat 566 people. At the north end there will be a choir gallery and priests' sacristy. The portion now being built includes a sanctuary, nave, and choir gallery, with seating accommodation for 250 people. The presbytery south of the church will accommodate two priests. The nave will be 84ft. long, 31ft. 6in. wide, and 40ft. high. The sanctuary will be approached by three steps, and will be 23ft. 3in. long, 27ft. wide, and 40ft. high. The style is Perpendicular Gothic. The external dressings will be of Portland stone with Kentish rag facings, and stock bricks relieved with red bricks, and a red-tiled roof. The internal dressings will be of Bath stone. The work is being carried out by Messrs. Gregar and Son, of Stratford, the architect being Mr. Curtis, of London Wall, E.C.

Mr. Robert Collier Driver, of Melrose House, Cromwell-road, and of 4, Whitehall, auctioneer and surveyor, a past-master of the Clothworkers' Company, who died on April 13 last, aged 81 years, leaving personal estate of the net value of £211,153, bequeathed to his sons, Charles William Driver, Robert Manning Driver, and James Hutchinson Driver, £5,000 each; to his son-in-law, Henry Jonas, £5,000; and other legacies to his sisters, daughters-in-law, and grandchildren. He also left to his cashier and head clerk £100 each, and to the Surveyors' Institution, of which he was Past President, £500 for a "Driver Prize," upon like conditions with the annual prize given by him in his lifetime. Mr. Driver bequeathed £10,000 upon trust for his son-in-law Henry Jonas and his children, and he left the residue of his property in equal shares to, or in trust for, his three sons.

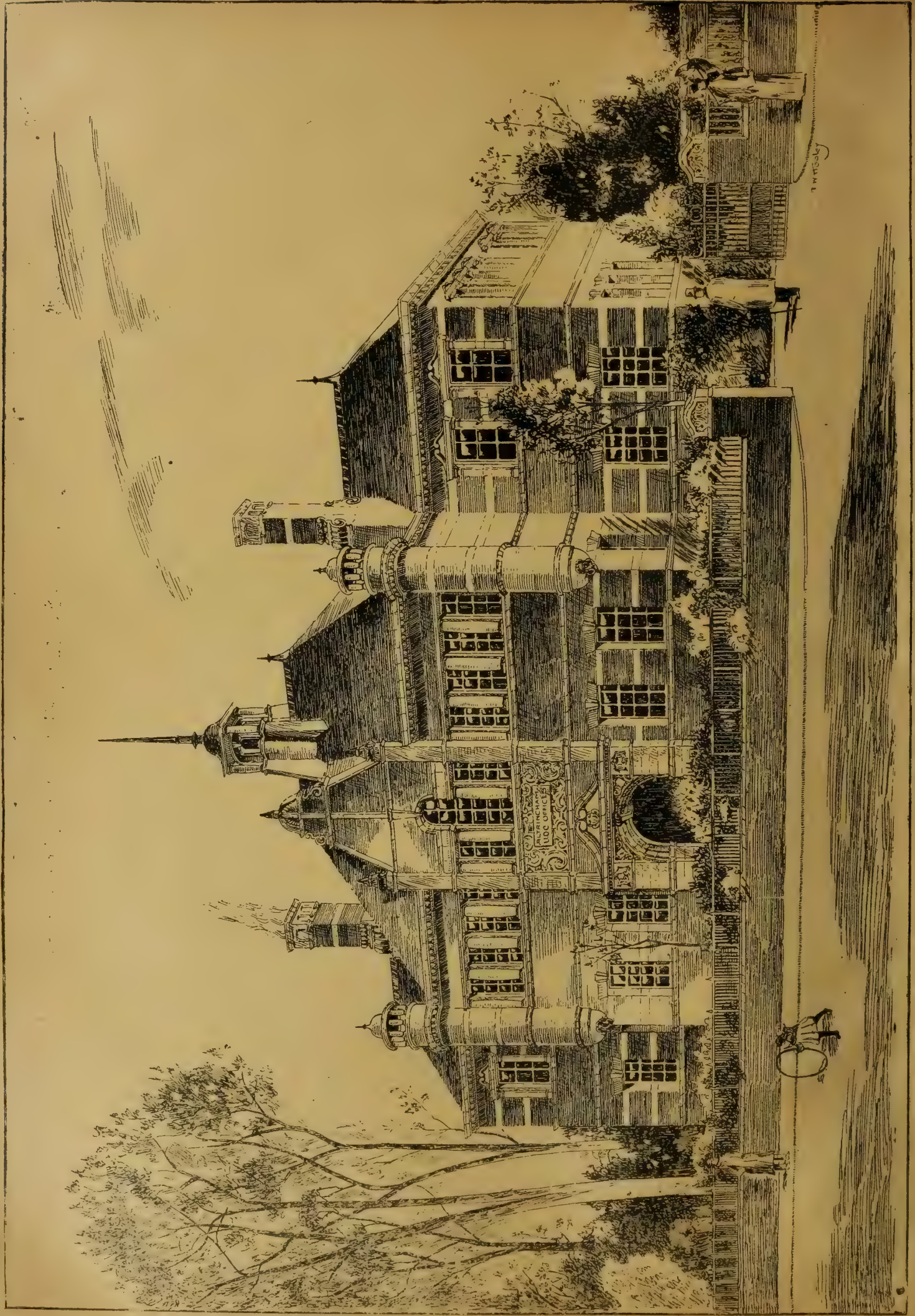

ALTRINCHAM TOWN HALL.







ROCHDALE COTTAGE

S BUTTERWORTH & J

JUNE 3, 1898.



PHOTO-TINT BY JAMES AKERMAN, 11 Queen's Square, London W.1

OMES, MIDDLEWOOD.

UNCAN, ARCHITECTS





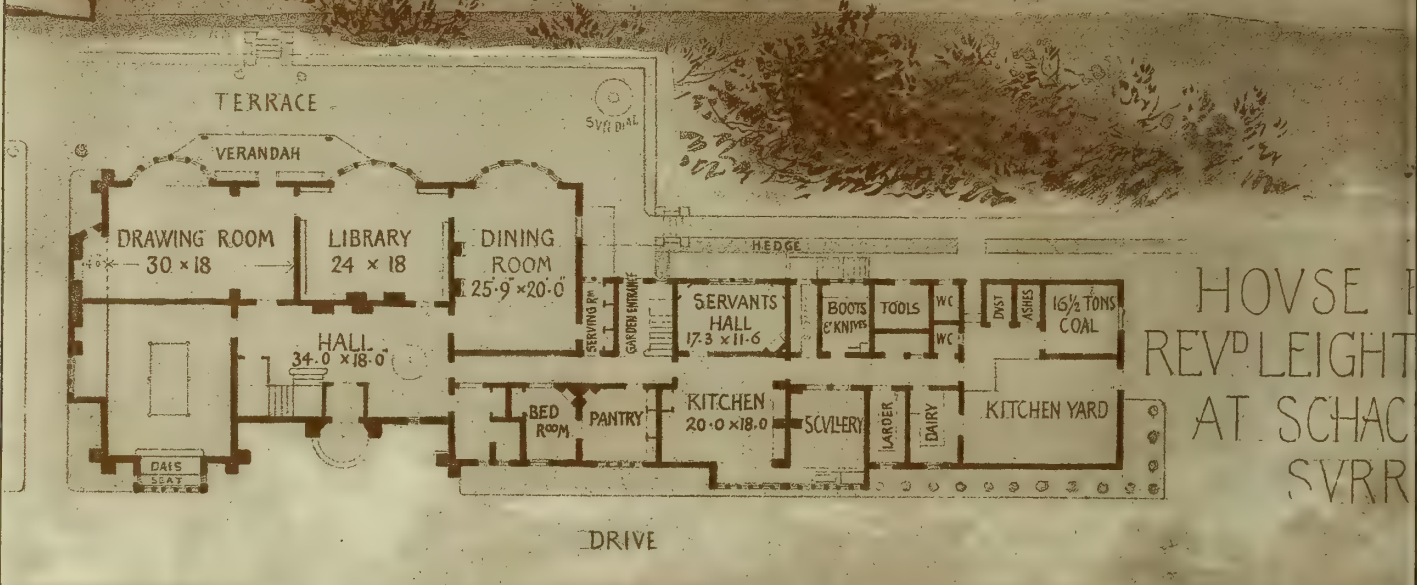



FOR THE  
N GRANE  
EFORD  
Y

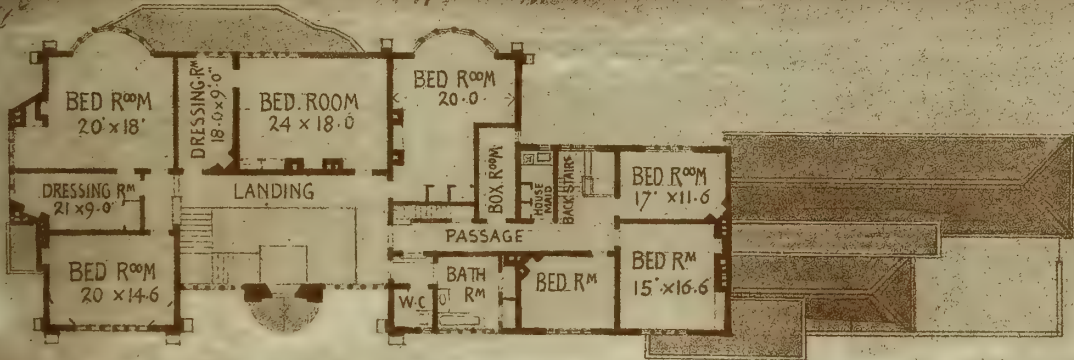

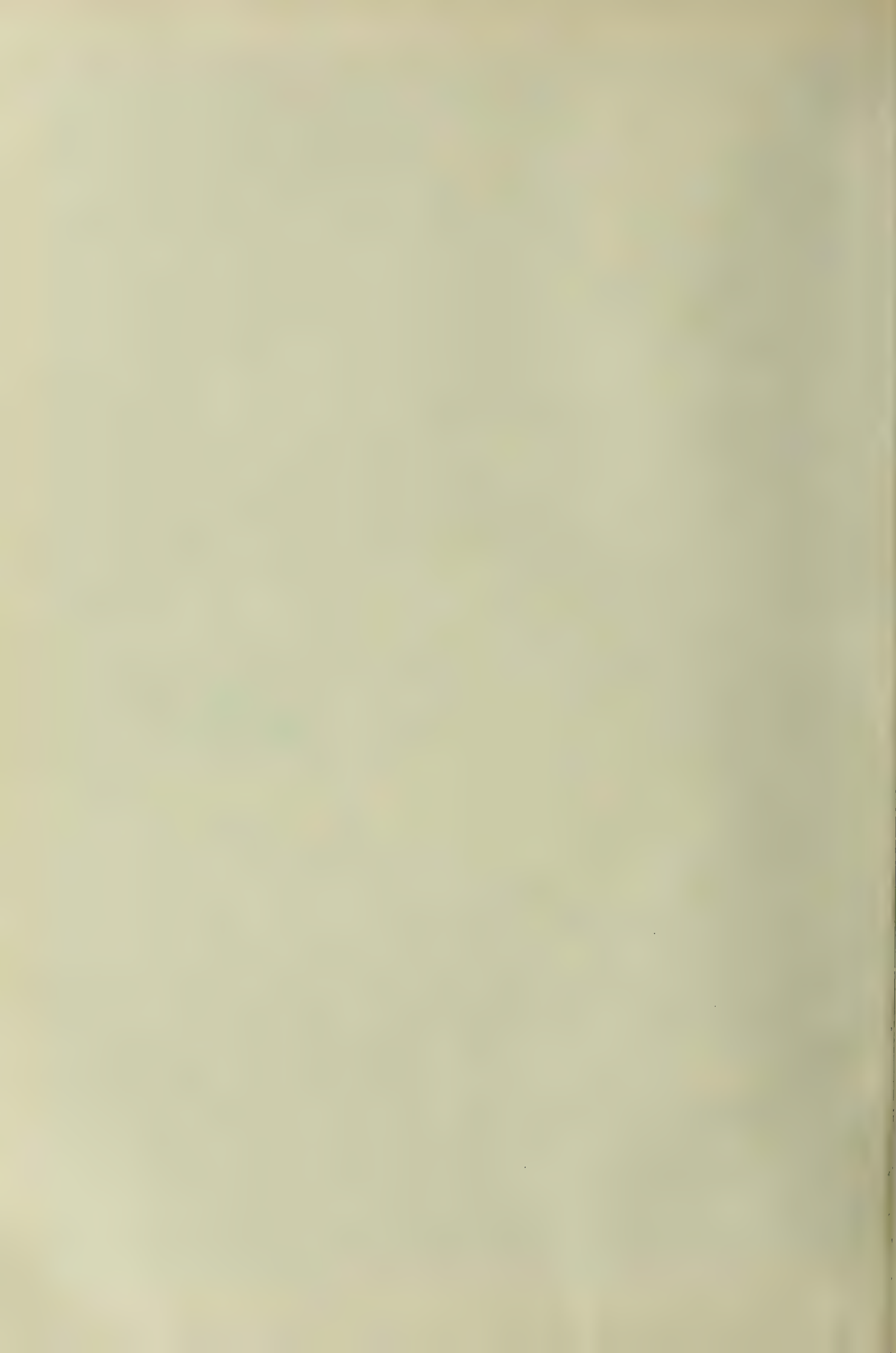







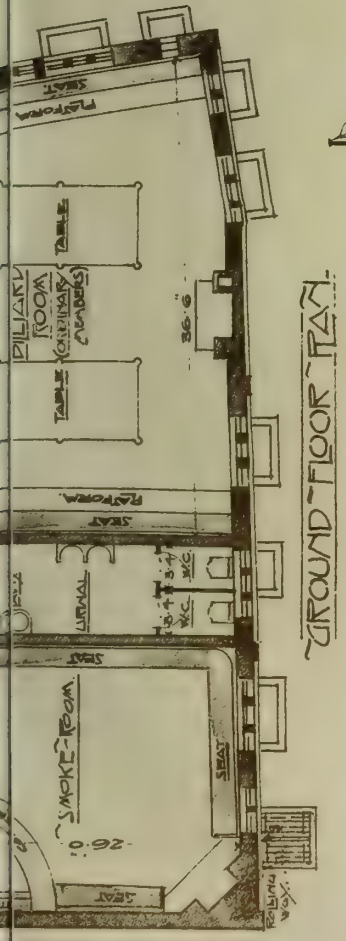

GROUND FLOOR PLAN



FIRST FLOOR PLAN

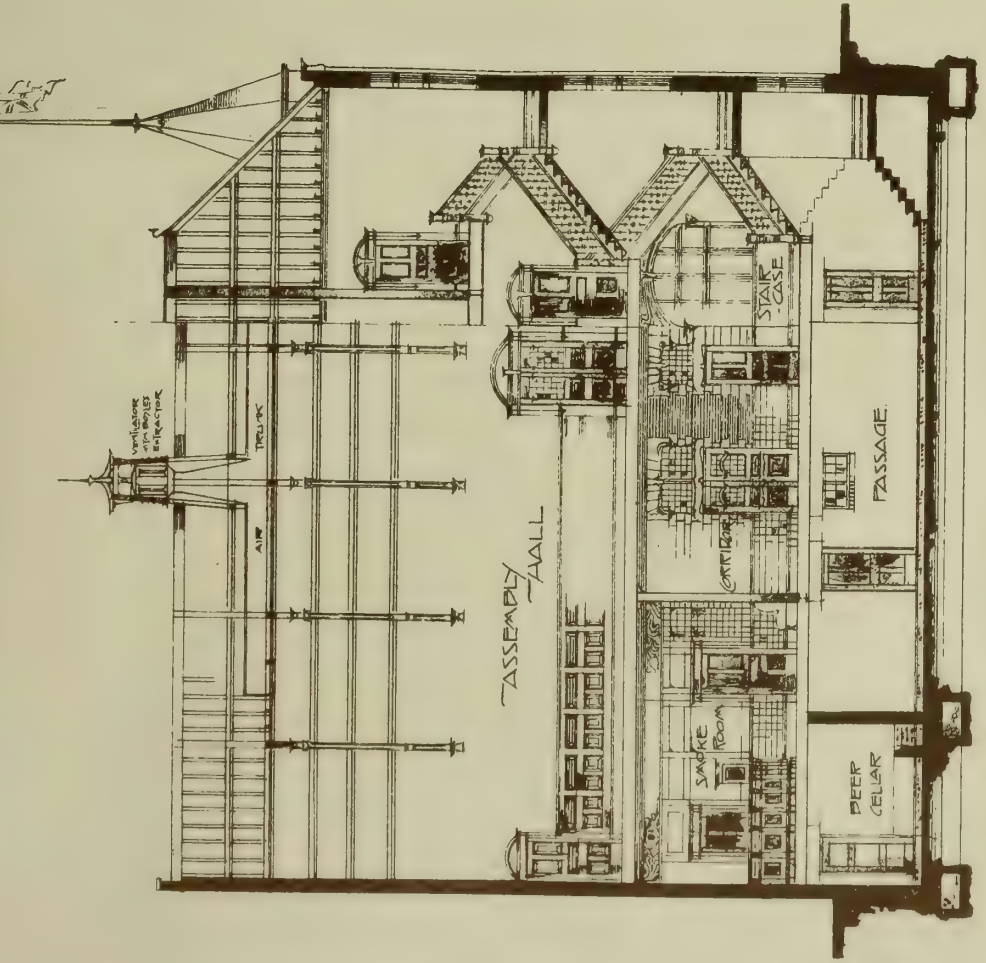

SECTION ON LINE B-B

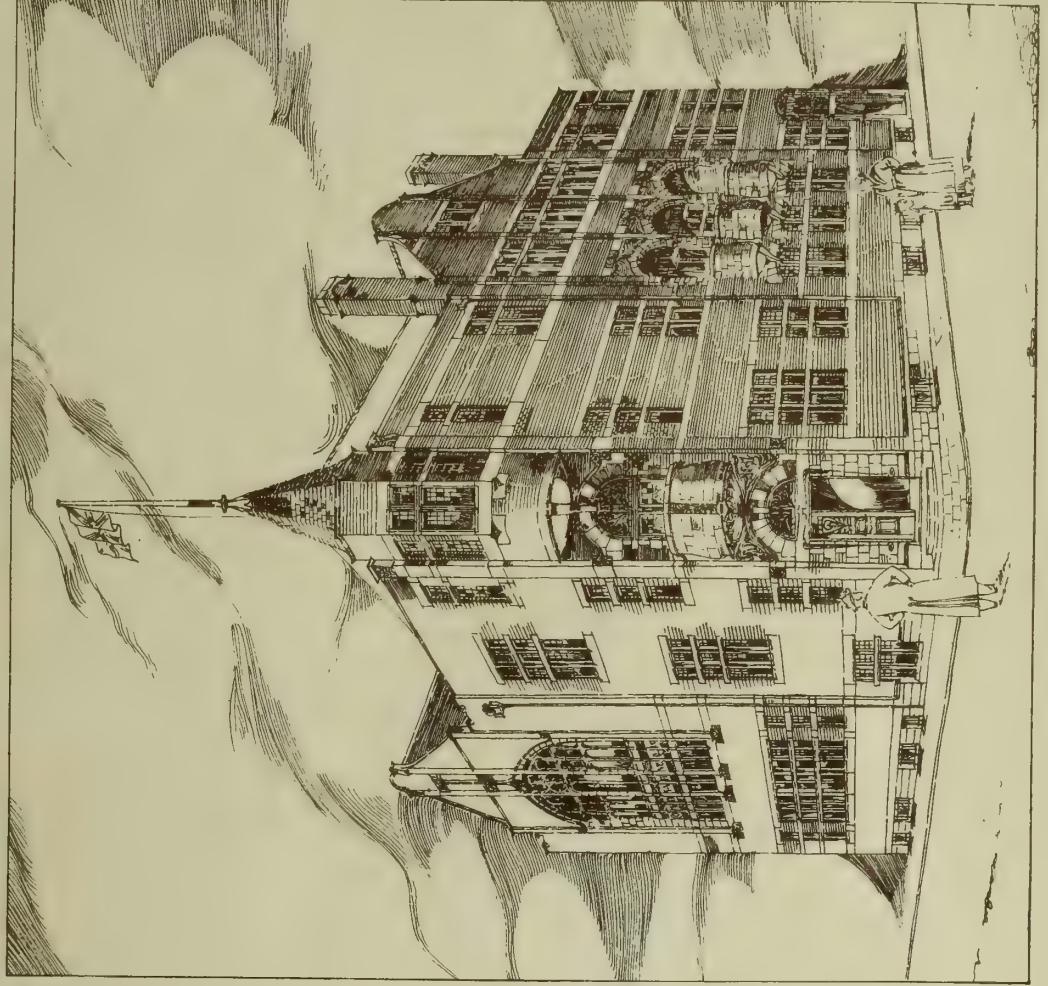

NUNEATON CONSERVATIVE CLUB COMPETITION  
 SELECTED DESIGN CHARLES W SMITH ARCHITECT

Photo Lithographed & Printed by Messrs. Alderman & Co. Ltd., Glasgow W.

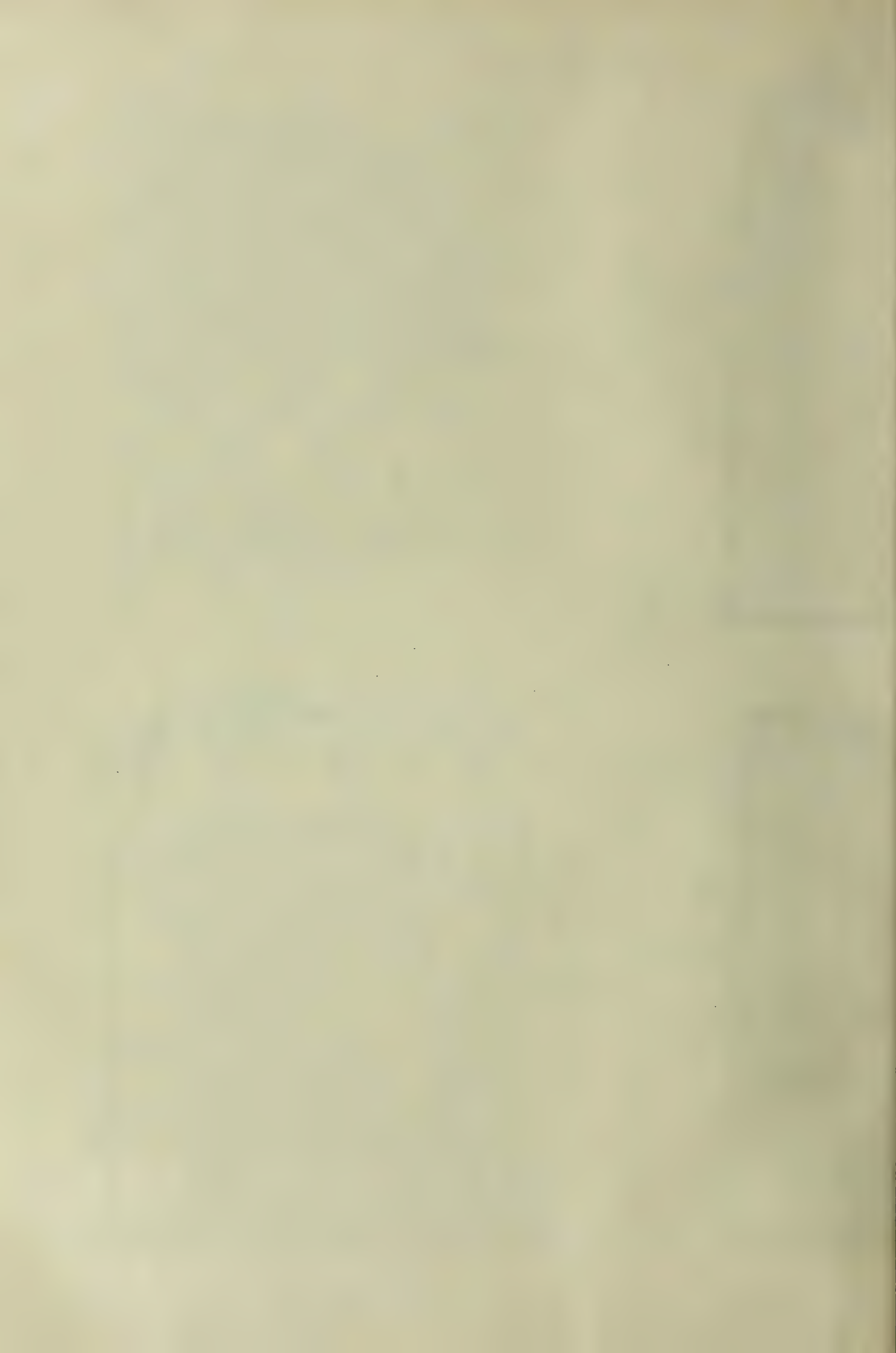





NATIONAL SILVER MEDAL DRAWINGS

BY A. B. ILLSTON.

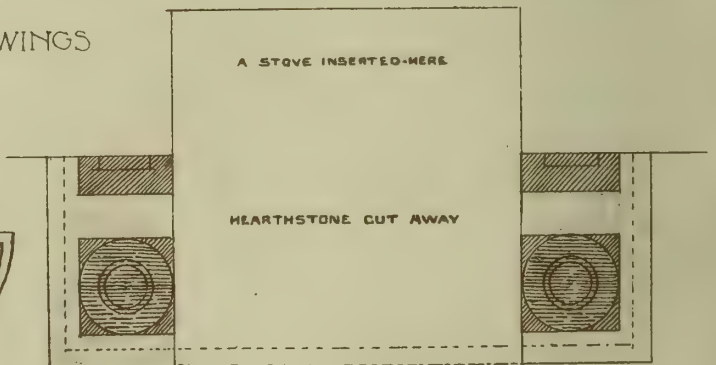

BLACK AND GREEN MARBLE, PILLARS, PANELS, AND BOSSES.  
ALABASTER, FRIEZES, CAPITAL AND ARCH.  
SANDSTONE.

FIREPLACE IN BOLSOVER CASTLE.  
FROM ACTUAL MEASUREMENT.

HOUSE AT THORPE MANDEVILLE.

C. F. A. VOYSEY, ARCHITECT

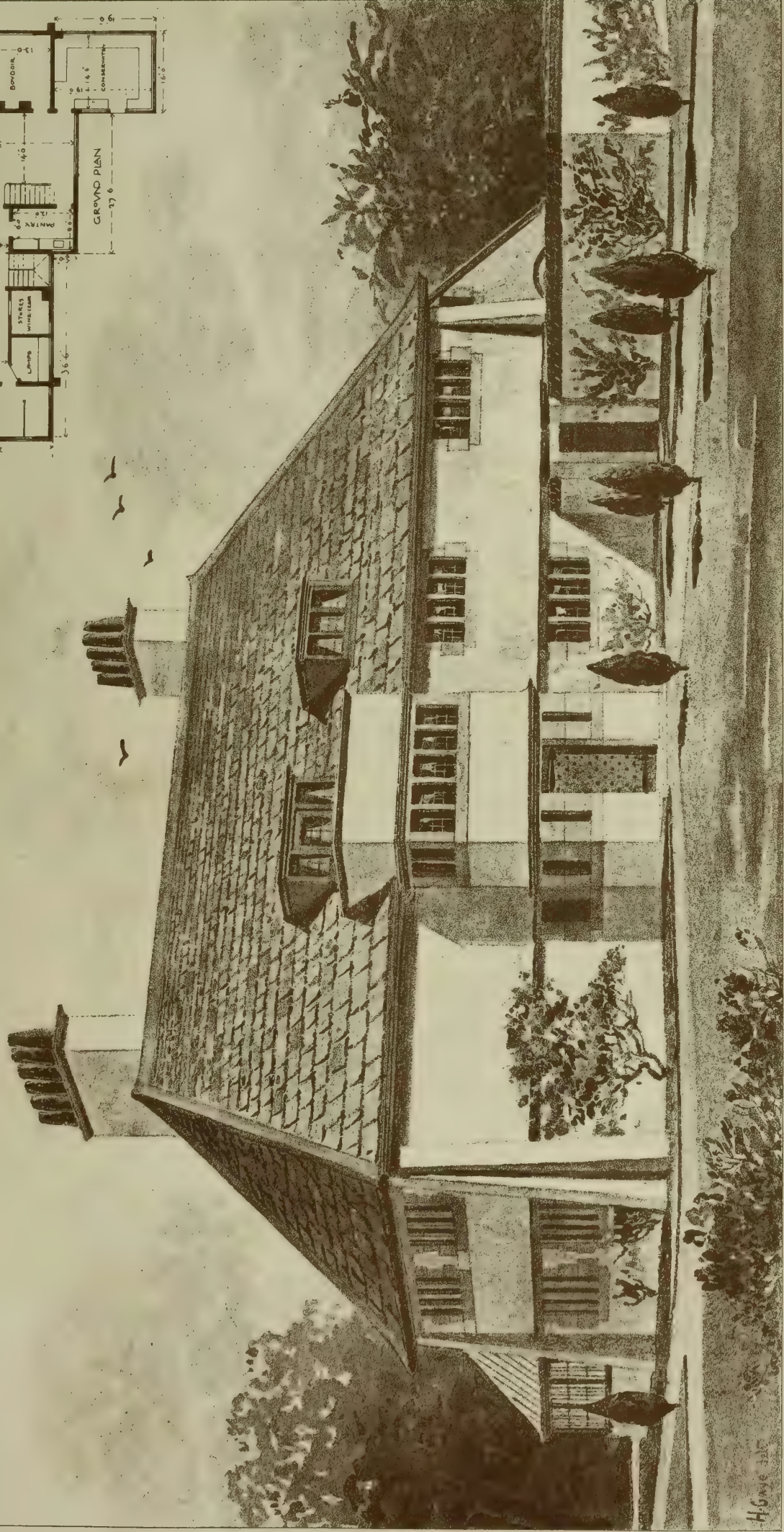
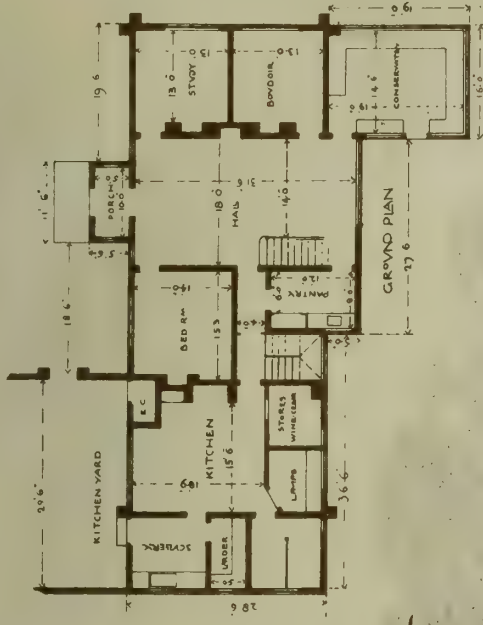





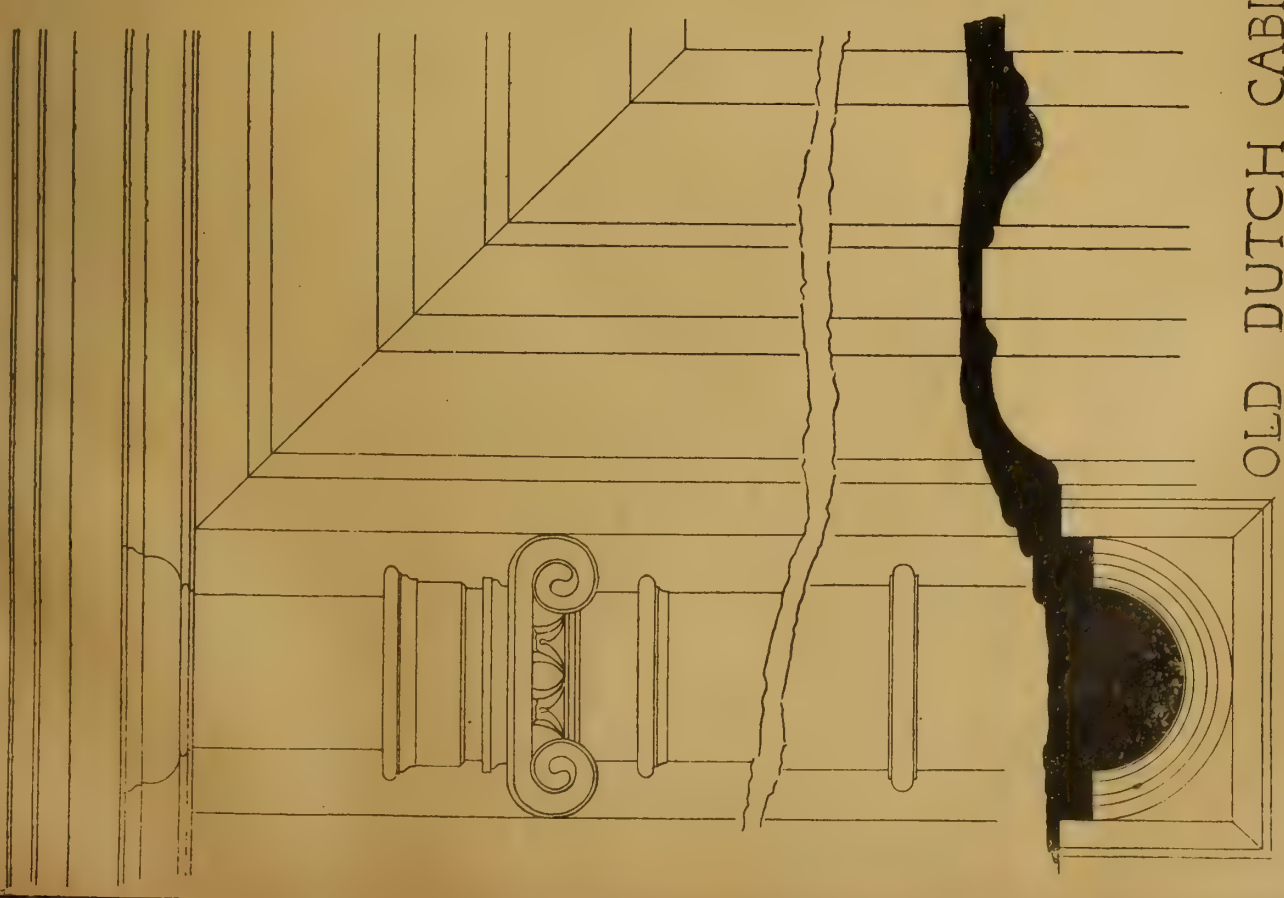

DETAIL OF CENTRE COLUMN.

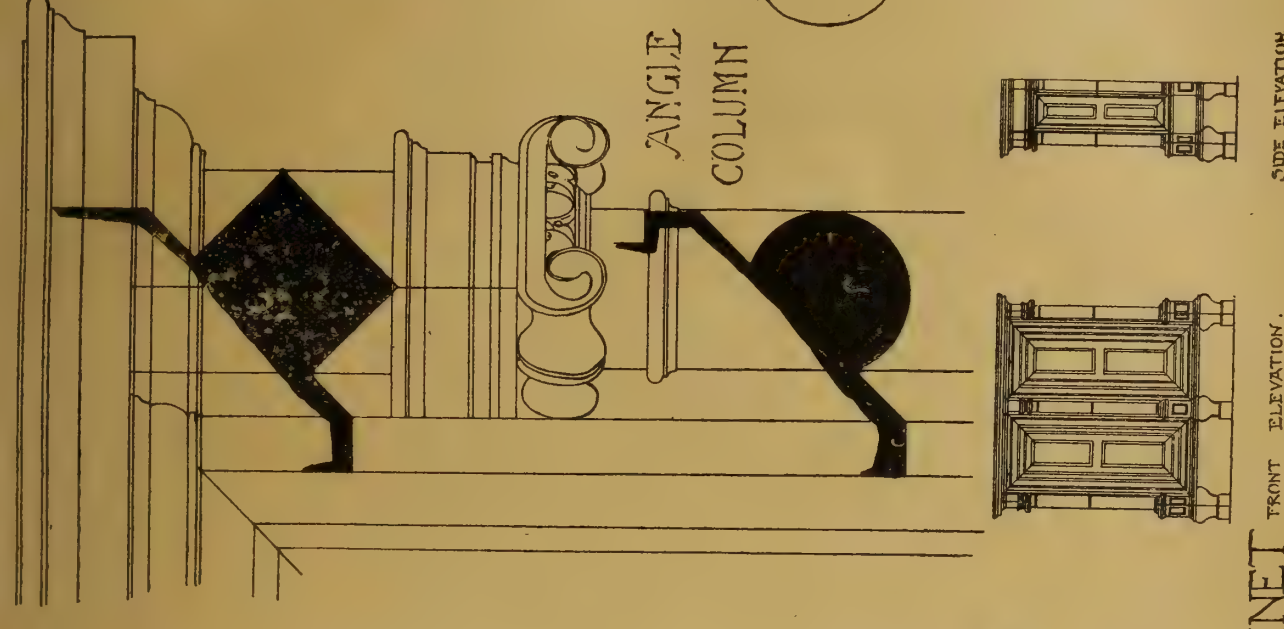

FRONT ELEVATION.

SIDE ELEVATION.

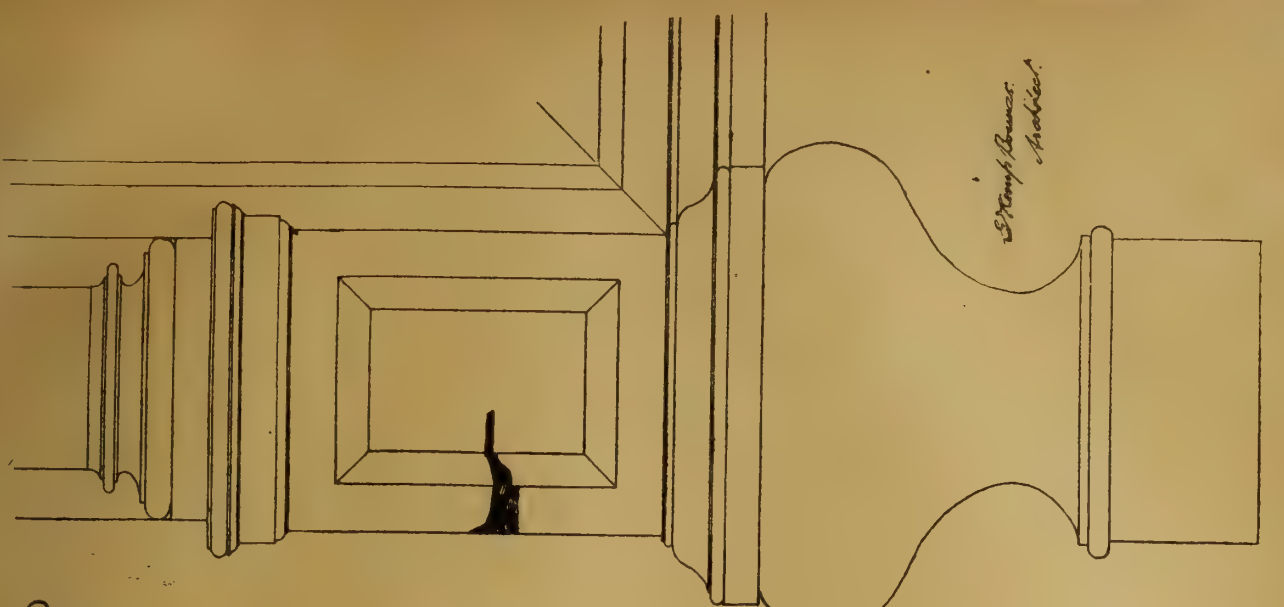

ANGLE COLUMN

*W. Kemp & Co. Architects.*

OLD DUTCH CABINET

## LEGAL INTELLIGENCE.

**THE L.C.C.'S POWERS TO REFUSE PLANS.**—Before the Metropolitan Tribunal of Appeal composed of Mr. Arthur Cates (president), Mr. A. A. Hudson, and Mr. J. W. Penfold, sitting at the Surveyors' Institution, an important case under the Building Act, and involving the rights of the London County Council to refuse to sanction plans for the erection of buildings under certain conditions, came on for decision on May 25. The case was one in which Mr. Charles Gillett, a builder, of 190, Elthorne-road, Upper Holloway, was the appellant, and the London County Council were the respondents. Mr. A. F. Wooten was counsel for the appellant, and Mr. F. Seager Berry appeared for the respondent council. Mr. Wooten, in stating his case, said the point in dispute was an important one as far as building construction in London was concerned, and had been brought forward in order to clear up any difficulties in that connection. Early in the present year Mr. Lawrence, as the architect to the appellant, submitted plans to the London County Council of two houses which it was proposed to erect in Hornsey-road. The houses were intended to be for the use of the working classes, and were to be let in tenements. On April 17th the Council refused to sanction the plans, but gave no definite reason for their refusal. It was held for the appellant that the plans were faultless, and that they were within the provisions of the Building Act. It had been satisfactorily shown that sufficient space was allowed for the admission of light and air. At the rear and front open spaces of 10ft. and 20ft. respectively were allowed, and the entrances gave a width of 12ft. between the houses, together with total lengths of 68ft. in the 12ft. way and 38ft. in the 20ft. way. The total air space allowed to the two houses was 750sq.ft. It was true that the buildings were to be erected on a strip of land between the backs of two rows of houses, but even then plenty of light and air space was provided. The appellant, therefore, claimed a verdict. Mr. Seager Berry, on behalf of the Council, pointed out that, although on the plans the appellant showed what was proposed to be the front of the houses, the Council held, as they were empowered to do, that the entrances for the front were on another side, and that if the plans were sanctioned the builder would be able to extend the length of the houses to a much greater distance than that for which the plans would be sanctioned. It was well established that there could be any number of fronts, and the Council were quite within their rights in saying that a certain part would be the front, notwithstanding what was shown on the plan. Then, again, part 5 of the Building Act laid it down that there should be a double current of air. The Council's point was the allowance of feet in front and behind, because if the houses were started they could be built block after block, and the builder could shelter himself behind the fact that he had so many feet of open space in front and so many at the back. It opened up a vast field for irregular construction in London, and the Council in consequence refused to permit the possibility of it by interpreting what they thought would be the front and back, and not what the architect or builder thought in that respect. It was the intention of the Legislature to prevent that mode of construction. The President: But their intentions are not always realised.—Expert evidence of a medical nature was then called, showing that if the houses were erected as proposed in the original plans they would practically form an insanitary area. The tribunal, after a lengthy deliberation, dismissed the appeal and made no order as to costs. Mr. Wooten applied for a case to be stated for the High Court; but the Tribunal reserved their decision as to whether their finding was based on points of law or matters of fact.

**INSUFFICIENT AND UNREASONABLE PRIVATE STREETS WORKS.**—**MANSFIELD CORPORATION V. BUTTERWORTH.**—In the Queen's Bench Division on May 21 Mr. Justice Wills and Mr. Justice Kennedy gave judgment in this special case stated by the justices of the Mansfield Division, before whom objections made under section 7 of the Private Street Works Act, 1892, by the respondent to proposals of the appellants with reference to a street called Quarry-lane were heard. The appellants, resolved, in pursuance of the Act, to execute works of paving, &c., in part of Quarry-lane, in their borough, and specifications of the proposed works, with plans and sections, an estimate of the expenses, and a provisional apportionment, were duly prepared and approved by the appellants. The provisional apportionment included a piece of land belonging to the trustees of Bellamy's Charity, having a frontage of about 200 yards on Quarry-lane, and hereafter referred to as the respondent's land. The respondent duly objected to the proposals of the appellants on the grounds specified in section 7 (d) of the Act—namely, "that the proposed works are insufficient or unreasonable, or that the estimated expenses are excessive." The proposed works were intended to be done over a part of Quarry-lane, about 677 yards in length. Both vehicular and foot traffic has increased in the street during the past 12 months, and

is increasing, in consequence of the erection (which is still in progress) of a street of houses on land abutting on and adjoining Quarry-lane, but at a further distance from Mansfield than the respondent's land. Vehicular traffic between the new street of houses and Mansfield passes through Quarry-lane. There is no made roadway or footpath, and no foundation to the road, which is uneven, with very deep ruts, but there is a footpath irregularly demarcated with rough stones. There are no sewers to carry off the sewage of the houses erected and in course of erection in the said new street, or of the houses adjoining Quarry-lane, and there is no provision for lighting it. In wet weather Quarry-lane is almost impassable. The average width of Quarry-lane throughout the 677 yards is about 16ft., and for several yards opposite the respondent's land the width is about 12ft. (inclusive of the rough footway referred to, which is 3ft. in width). At other points in the street where the respondent's land does not adjoin Quarry-lane its width is from 14ft. 6in. to 16ft. It was admitted that the estimated expenses stated in the provisional apportionment were not excessive. In support of the respondent's objection it was contended that, inasmuch as it was not part of the plan of the appellants' proposed works that Quarry-lane should be widened opposite any part of the respondent's land, but that the works should be executed whilst retaining Quarry-lane at its present width, the proposed works would be insufficient and unreasonable, and that the insufficiency and unreasonableness meant by the statute had reference to the probable requirements of future vehicular traffic as well as, in addition to, the requirements of present vehicular traffic. For the appellants it was contended that the justices could not find that the proposed works were insufficient and unreasonable within the meaning of section 7 of the Act on the ground only that they considered that the street ought to be widened before any works were done, and that the insufficiency and unreasonableness meant by the statute must be in respect of the nature and character of the proposed works, having regard to the present condition of the street and the traffic over it. The justices were of opinion that the proposed works were insufficient and unreasonable on the ground that the existing width of the highway (that is to say, 9ft. roadway and 3ft. footway) at the point before mentioned was insufficient for a highway, and that such works or any part thereof ought not to be done unless and until the street was made wider, and they therefore adjudged that the works were insufficient and unreasonable on the ground that such proposed works involved the retention of the present width of the street without enlargement. The question for the court was whether the justices could find on the grounds above stated that the proposed works were insufficient and unreasonable within the meaning of section 7 (d) of the Act. The court allowed the appeal. Mr. Justice Wills said the Act provided that where a street was not in a state satisfactory to the local authority, they might resolve that certain works should be done, comprehending such works as had been ordered in the present case. The objections that could be made were specified in section 7. Certain of the objections—two of them beyond all doubt—went to the root of the whole scheme, because, if they were valid in fact, they went to establish a state of things in which the local authority had no jurisdiction to pass the resolutions. That was much as it was under section 150 of the Public Health Act, 1875. Under that section the local authority might pass resolutions, execute works, and apportion expenses. But if it turned out that the alleged street was not a street, the whole foundation of the proceedings failed, and the person proceeded against escaped. The Act of 1892 preserved objections of this class, and provided for objections of other kinds. Then the Act gave the justices power, where an objection succeeded, to quash "the resolution." Looking at the whole scheme of the legislation and more particularly at the fact that under section 7 there was a large class of objections relating to the plans and matters of that kind, he thought it impossible to doubt that the jurisdiction of the magistrates was to quash the resolution approving the plans. That was just as effectual in the case of a place which was not a street as if the original resolution were quashed. In the present case the Court was specially concerned with the objection, under clause (d) of the section, "that the proposed works are insufficient or unreasonable." At first sight that objection to proposed works might appear to be an objection of the same class as the objection that the place was not a street, going to the root of the whole scheme. But the language of the clause was capable of another construction—namely, as referring to the works as specified in the plans and sections. This was the true construction of the clause, and the Act was not intended to interfere with the jurisdiction of the local authority to adopt the scheme as a whole, but merely to give the justices power to consider the sufficiency and reasonableness of the way in which the work was proposed to be done. The first ground of the objection was the insufficiency of the works. In his opinion, the expression "insufficient" in the clause did not

mean insufficient having regard to some matter which might make a better scheme for the neighbourhood in general. The other ground of the objection was the unreasonableness of the works. "Unreasonable" was a much wider word. It did give power to the justices to consider whether or not the thing proposed to be done was as a whole a reasonable thing to be done. That followed from "Sheffield Corporation v. Anderson," where it was held under a local Act similar to the Act of 1892 that the justices had power to say that under the circumstances a sewer was not required for a street. He thought there was no reason to quarrel with that construction of the Act. And if the magistrates had found in this case that the works ought not to be done at all—that is to say, that the works were not required, and had held that the scheme was unreasonable, on that ground they would have had jurisdiction to disapprove of it and quash the resolution approving the plans. But it was plain that the magistrates had not decided anything of that kind. He thought the magistrates had thought it would be a very good thing to have the street made wider, and that they would put the screw on the corporation and get the street widened by withholding their approval of the scheme. It was clear from their deciding that the work was insufficient that they were thinking of the insufficiency of the general scheme for the good of the public; a matter they had no power to consider. And it appeared that they found that the work was unreasonable because they thought that the corporation ought to add to their scheme a widening of the street. The magistrates' order must therefore be quashed, and the appeal allowed. Mr. Justice Kennedy delivered judgment to the like effect.

**VALUE OF LAND IN WESTMINSTER.**—At the Surveyors' Institution on Friday, an arbitration case, involving a claim for £15,000, the alleged value of land at Westminster, came before Mr. Arthur Cates, president of the Metropolitan Tribunal of Appeal, sitting as sole arbitrator. The parties to the action were the Governors of the Bounty of Queen Anne (the Ecclesiastical Commissioners), claimants; and the united vestry of the parishes of St. Margaret and St. John the Evangelist, Westminster, respondents. Mr. Cripps, Q.C., appearing for the claimants, said it would devolve upon the arbitrator to lay down what was the value of the land in dispute. The Vestry of Westminster under a scheme of improvement proposed to widen Great Smith-street. For that purpose it was necessary to acquire property at present existing in the street, and known as Nos. 1, 3, and 5, Great Smith-street, which belonged to the Governors of Queen Anne's Bounty. The vestry some time ago approved and adopted a scheme of improvement in the street, and had already agreed with the Ecclesiastical Commissioners for the purchase of a portion of No. 3, The Sanctuary, Westminster, which abutted on the northern boundary of the property sought to be acquired. For the purposes of the improvement, however, it was found that it was necessary to secure the houses known as Nos. 1, 3, and 5, Great Smith-street, and notice to treat was accordingly served on the Governors of the Bounty. The case for the claimants was that the value of the land which the vestry desired to compulsorily purchase was much greater than that placed upon it by the vestry. The value stated was held to fairly represent the value of the property. Expert evidence was given by Messrs. Penfold, Currey, and Watney, who, in the main, agreed as to the value of the land. For the vestry Sir William Marriott contended that the charge for the land was altogether too high. Expert evidence was given for the vestry, setting out prices for the land considerably lower than that put upon it for the other side. The arbitrator reserved his award.

A new American brickmaking machine is being tried at some of the Peterboro' brickyards.

The partnership heretofore subsisting between F. B. Wade and H. G. Sargent, architects, Sloane-street, S.W., under the style of Wade and Sargent, has been dissolved.

At the town-hall, Withington, last week, Colonel Hepper, R.E., one of the Local Government Board inspectors, held an inquiry with reference to an application of the urban district council for power to borrow £421 for sewerage works on the Fielden Park estate. The local authority was represented by Mr. A. Roberts, the clerk, and Mr. A. H. Mountain, surveyor.

What is claimed to be the largest pontoon in the world has just been launched from the ship-building yard of Messrs. Swan and Hunter (Ltd.), Wallsend. The pontoon, which has been built to the order of the Vulcan Shipping Company, Stettin, to which port it will be towed, is 510ft. long, 110ft. wide, and 42ft. 6in. high, and its lifting power is put down at 11,000 tons. This weight can, however, be increased by tower auxiliaries similar to those introduced in the case of the large pontoon recently built by Messrs. Swan and Hunter for the Spanish Government.

## PROFESSIONAL AND TRADE SOCIETIES.

ROYAL ARCHAEOLOGICAL INSTITUTE.—A general meeting of the members of the Royal Archaeological Institute was held on Wednesday at 20, Hanover-square, W., Judge Baylis, Q.C., presiding. Viscount Dillon having resigned the presidency of the Institute, Sir H. Howorth, M.P., was unanimously elected in his stead. Mr. G. E. Fox, F.S.A., gave a description of some black and white mosaic work on the floor of the calidarium of a house at Pompeii, presumed to have been inhabited by M. Caesius Blandus, a centurion of the 9th Praetorian cohorts. Mr. Fox also described a dwelling-house recently uncovered during the excavations on the site of the old Roman city at Silchester. He explained that this was one of the largest houses which had yet been discovered in the course of the excavations. It was of the courtyard type, and very substantial. The same type was not found amongst the remains of Roman houses at Pompeii. Elaborate arrangements were discovered for heating by means of hot air, and traces were also discernible of the use of braziers for heating purposes. There were corridors on each side of the living-rooms, and fragments of a very fine mosaic pavement had been found in one of the rooms. Supplementing Mr. Fox's information, Mr. F. Davis, who had been present during the uncovering of this house, stated that it had been erected upon the site of an earlier structure. Some 2ft. below one of the floors they had discovered a tessellated pavement which clearly belonged to another and more ancient house. On the south-west corner was found an inclosed chamber paved with very large flagstones. It was the only structure of the kind which had been found at Silchester during the nine years he had been working there.

## CHIPS.

The Northern Branch of the Somersetshire Archaeological Society had an agreeable meeting at Stanton Drew on Wednesday week, when the vicar, the Rev. H. T. Perfect, acted as guide.

It is stated that the Queen will lay the foundation-stone of the new front of the South Kensington Museum some time in July.

A new town hall is about to be built in Church-street, Oakham, at a cost of about £3,000. The architect is Mr. Edmund Jeeves, of Melton Mowbray.

A new cleansing depot for Glasgow was opened in Graeme-street on Tuesday. The site, 1,864sq. yds. in extent, cost £4,893, or 52s. 6d. per yard, and the outlay on buildings and machinery amounts to nearly £13,500. On the south side of the yard there are a granary and food-mixing machinery, with the ground floor set apart as a cart shed. On the west side are the stables, which occupy three flats, with cart-sheds underneath. Each flat has 20 stalls and four loose boxes, giving accommodation for 72 horses. The north side of the yard is occupied with general stores, offices, muster hall, and saddlers' workshop.

Mr. Edward Mackeson, of 13, Hyde Park-square, who died on March 12, aged 81, desired in his will that his picture of "The Burial of St. Catharine," by Mucke, and the picture of his father's ship should be offered to the Royal Academy; if refused by the Academy, they are to be retained by the executors for their own use, or sold for the benefit of his residuary estate.

The Hôtel Ritz, a new hotel which has been erected in the Place Vendôme, Paris, was opened on Wednesday. There are 150 apartments in the hotel, which stands on the site formerly occupied by the old Lievin mansion, some of the architectural features of which have been preserved in the new building.

An important addition to the fittings of the church of St. Aidan, Leeds, was dedicated last week. A rood was a part of the original design, and from the opening of the church a heavy oaken beam across the entrance to the choir has indicated its position. It has now been finished, at a cost of £300, from designs by Mr. Crawford Hick, the architect of the church work. In the centre stands a figure of the Saviour hanging on the Cross, flanked by figures of the Blessed Virgin and St. John the Evangelist. At the extremities of the supporting beam are kneeling figures of adoring angels, with folded wings.

A stained-glass window has just been placed in German Church, Bradford, by Mr. Delius. The subject is taken from the well-known print by Hofmann, illustrating the text: "Where two or three are gathered together in my name," &c. The window has been designed and executed by Messrs. Powell Bros., of Park-square, Leeds.

## Our Office Table.

In a letter which appears in Wednesday's *Times*, Mr. G. A. T. Middleton, A.R.I.B.A., draws attention to the responsibilities of architects, as suggested by the verdict of manslaughter against the architect returned by the coroner's jury in the case of the Abbey-mansions disaster. This verdict, he says, raises a point of serious public interest, for it amounts to a declaration of want of skill or knowledge upon the part of the architect, and the question arises as to how large a proportion of architects are fully competent to protect the lives of the public using their buildings. As Mr. Middleton points out, anyone may pose and practise as an architect. There is no compulsory training, no compulsory examination, and the only voluntary examinations, those of the Royal Institute of British Architects, are deplorably weak on the scientific side—weak to the extent of danger. Some few thoughtful men long since recognised this, and promoted a Bill which would place architects, in the matter of training and examination, upon the same footing as doctors and lawyers. Is there, he asks, no member in the House who at this moment, when public attention is drawn to its importance, will take the matter up and not rest until the Bill becomes law?

The Dean of Canterbury draws attention to the fact that the available burial space in Westminster Abbey is almost exhausted, and asks whether it is not the duty of the nation to improve the surroundings of the Abbey, and above all to connect it with a memorial chapel such as has already been planned and suggested? For many centuries the stream of English history has, Dr. Farrar remarks, flowed through the precincts of our famous Abbey Church; and many instances might be adduced of the deep and stimulating impression which has been created in the minds of illustrious men by the great memories which it enshrines. That Westminster Abbey should henceforth be severed from its immediate connection with the story of our Empire would, he thinks, be nothing short of a national misfortune.

WE are pleased to observe that the north-east staircase leading to the Raphael Gallery at South Kensington Museum, which was recently condemned by the House of Commons Committee as dangerous in case of fire, has been altogether removed, and is now replaced by a stone vestibule connecting the Sheepshanks and the Cartoon Galleries, which will hereafter be hung with pictures. A piece of tapestry has just been hung on the wall at the top of the library stairs at the same museum. It was executed by Mr. William Morris, its subject being the Four Seasons, and is the only one designed by himself, all the other tapestries produced by him having been designed by Sir E. Burne Jones. The new Cross Gallery and its thirteen rooms, devoted to the Oriental collections, are now completely arranged. Entering by the south-east stairs, there is a series of sketches made by Sir William Simpson, R.I., in India, during the Mutiny. The first three rooms contain woodwork, pottery, textiles, and metal-work from Egypt, Syria, and Turkey, including several specimens of large lattice-windows from Cairo, and two sides of different rooms from Damascus. There are also a collection of tiles from Constantinople and Damascus, and two cases of Saracenic glass lamps. The next three rooms contain similar collections from Persia, but are richer in pottery and textiles. A number of full-size coloured copies of beautiful tile-work from Ispahan is shown here. The two succeeding rooms and part of another are devoted to Chinese art-work, principally porcelain. The two further rooms are devoted entirely to the Japanese collection.

DR. PIGOU, the Dean of Bristol, has issued a fresh appeal for £2,620 to complete the restoration of his Cathedral. He states that up to the present date the following works have been completed by Messrs. Cowlin, of that city, under the direction of the late Mr. J. L. Pearson:—Central tower, Lady-chapel, cloisters, choir-roof, parapets of south choir-aisle, and eastern end of choir; the northern, eastern, and southern bays of the eastern Lady-chapel, the last bay of which is now being completed. The expenditure already sanctioned will allow of completing the eastern bay of the south choir-aisle. There remain the following works and the approximate estimate for their completion:—To finish Berkeley chapel, £620; north choir-aisle, £900; south choir-aisle, £450; Newton

chapel (approximate), £300; roof of Berkeley chapel, £200; south transept, £150; making the total already named of £2,620. As to the south-western side of the cathedral, it is, the Dean states, no exaggeration to say that it is in a ruinous condition, and imperatively requires thorough restoration.—It is not a matter of sentiment, but of urgent necessity, for the preservation of the fabric itself.

AN archaeological discovery of some interest has been made at Dublin in the course of the operations for electrically equipping the Tramway Company's system. While digging a man-hole in connection with the feeder cables close to the walls of Trinity College and opposite the end of Dawson-street, the workmen came on a vault-like structure which on further investigation turned out to be a covering for the famous well of St. Patrick, the exact site of which has been a matter of doubt for some centuries. It appears that the well formerly stood within the grounds of the college; but when Nassau-street was being widened sixty years ago the footpath was built over the wellhouse, which, however, still continued to have an entrance from the Fellows' Garden of the college. With the exception of the late Dr. Stubbs, who always maintained that this was the famous well of St. Patrick, the college authorities do not seem to have interested themselves in the matter, and while antiquarians conjectured, from the fact that Dawson-street was formerly called St. Patrick's Well-lane, that the original well must have been close to the end of Dawson-street, they were unaware of the existence of the well at the edge of the Fellows' Garden which has now been discovered.

THE Sun Insurance Office report for the year ending 31st December, 1897, states that the premiums received, less re-insurances, amount to £1,012,340 8s. 5d., being an increase of £42,655 11s. 5d. as compared with those of the preceding year. The total of the sums insured during the year, after deduction of the amounts re-insured, exceeds £425,000,000, being an increase of about £36,000,000 on the corresponding figures for the year 1896. The losses paid and outstanding amount to £588,296 6s. 7d., being at the rate of 58·11 per cent. on the premiums received. The expenses of management (including commission to agents and working charges of all kinds) amount to £343,252 3s. 10d., being at the rate of 33·91 per cent. The income from investments during the year has amounted to £78,671 16s. 4d. After providing for the usual reserve of 40 per cent. of the premiums to cover liabilities under current policies, a balance of £142,401 9s. 10d. remains, which has been transferred to the credit of the profit and loss account.

The Duke of Cambridge opened on Wednesday a new isolation hospital at Isleworth, for the joint use of the boroughs of Richmond and Hounslow with Isleworth.

The foundation-stone of the church of St. Faith, Crosby, near Liverpool, was laid last week. The church will accommodate 800 persons. It will be of brick faced with Accrington bricks, with red Bun-corn stone dressings. The nave will be 109ft. long, and 39ft. wide, with narrow aisles 74ft. in length. The transepts will be 22ft. square, and the chancel 42ft. in length. The fittings and endowment will cost £20,000. Messrs. Grayson and Ould, of Liverpool, are the architects.

With the commencement of warm weather the members of the British School of Archaeology in Athens have discontinued their excavations in the island of Milo, and will not resume their work until the return of winter. Up to the present the results of their search have been the discovery of an acropolis beyond the town. Recent investigations have brought to light fresco paintings of great importance as examples of primitive art. They represent men holding fish in their hands, and on the wall are primitive vases.

As many as 99 applications came before the Glasgow Dean of Guild Court on Friday, and although that number has been exceeded, the valuation of the proposed buildings and alterations, £273,000, is the highest on record in the Court. Two of the plans presented to the Court were for the erection of one building 92ft. high and another 119ft. high. The master of works objected to these plans being passed, owing to the great height of the proposed buildings, which, he said, would constitute a serious danger in case of fire, as the pressure of the mains was only sufficient to send water to a height of 73ft. The plans for the 92ft. building were passed, but the Court thought it advisable to delay consideration of the others.

## MEETINGS FOR THE ENSUING WEEK.

**SATURDAY (To-Morrow).—**London Architectural Association. Visit to Sutton Place, near Guildford. By rail to Worplesdon per 1.50 p.m. from Waterloo (main line).

Edinburgh Architectural Association. Annual excursion to Alloa and Clackmannan. Leave Waverly Station 9.10 a.m.

St. Paul's Ecclesiological Society. Visit to the Church of Northolt. Book to Southall Station via Ealing, by District train, leaving Mansion House at 2.42 p.m.

**MONDAY.**—Surveyors' Institution. Annual meeting. 3 p.m.

Royal Institute of British Architects. Business meeting. 8 p.m.

Carpenters' Hall, London Wall, E.C. Lecture by James Bartlett, M.S.A., on "The Setting-Out and Construction of Staircases." 7.30 p.m.

The new lavatories for men and women in City-square, Leeds, were opened to the public on the 28th ult. The whole of the fittings have been prepared from special designs, and have been carried out in glazed fireclay and earthenware by Messrs. Doulton, Twyford, and others. The whole of the works have been designed and carried out under the superintendence of Mr. W. Bakewell, F.R.I.B.A., for the corporate property committee, Leeds. Mr. Henry Whiteley has acted as clerk of the works.

Owing to the Epsom race meeting and the approaching Whitsun holidays, business at the London Auction Mart was naturally restricted last week, and the returns fall far below those of the corresponding week in last year, which was not similarly influenced. The total only amounted to £87,881.

The Prince of Wales, who is Vice-Patron of the North London, or University College Hospital, will lay the foundation-stone of the new building now being erected through the generosity of Sir J. Blundell Maple, Bart., M.P., on Tuesday, June 21st. We illustrated the hospital, which will be carried out from plans by Mr. Alfred Waterhouse, R.A., in our issue of May 8, 1896.

Major General F. D. Crozier held a Local Government Board inquiry at Bury, Lancs, on Friday, in reference to an application by the Bury Rural District Council for sanction to borrow £1,200 for the sewerage of Walshaw. The Bury Corporation had refused to deal with the sewage, and in consequence of pressure by the Mersey and Irwell Joint Committee the Local Government Board in January issued an order for the district council to do the work.

The foundation-stone of St. Mary's Priory Church, Princethorpe, was laid by the Bishop of Birmingham on the Feast of Our Lady Help of Christians. The church, which was designed by Messrs. Pugin and Pugin, of Westminster, will be completed by October, 1899.

An electric tramway at Kidderminster was opened on Monday. The corporation have resolved to sell to the British Electric Traction Company the power possessed by them under the electric lighting order obtained seven years since, the company undertaking to at once construct works for supplying electric light for town purposes. The corporation lay down conditions as to the repurchase of the power and works, if deemed necessary, at the end of a stated period.

An inquiry has been held at Llanidloes by Mr. H. Percy Boulnois, M.I.C.E., an inspector of the Local Government Board, into the application of the town council for sanction to borrow £12,000 for the purpose of carrying out the scheme of Messrs. F. Beesley and Son for the water supply of the borough, and other improvements.

Mr. E. B. B. Newton, of the Rochdale borough surveyor's department, has been appointed assistant surveyor to the Paddington Vestry, W., at a salary of £300 a year.

A United Free Methodist chapel in Carlton-street, Burton-on-Trent, was opened on Wednesday week. Messrs. Mason and Sons were the builders.

At the meeting of the Middlesex County Council at the Guild Hall, Westminster, on Thursday, the Asylum Committee presented a report, in which they recommended the purchase of an estate of 414 acres at Napsbury, St. Albans, at a cost of £50,000, for the erection of a new county asylum. On the site are eight cottages, a modern farmhouse, and farm buildings, which it is proposed shall remain. The price first asked was £60,000. The sum of £50,000 works out at £113 10s. an acre. The report was adopted without discussion.

The Leeds School Board have agreed to purchase 13,672sq.yds. of land at 10s. a yard in Burton-avenue, off Dewsbury-road, for the purpose of erecting a higher grade school and other premises thereon. Buildings will be erected thereon to accommodate 2,500 children.

## Trade News.

## WAGES MOVEMENTS.

**BOLTON.**—A meeting of master joiners was held on Tuesday evening to consider the present dispute. The operatives demanded Easter Monday as a holiday, an increase in overtime rates, an addition to the sum allowed for lodging money, and the introduction of an apprentice rule. The employers gave way on all points except the apprentice rule. They declined to allow any restriction of the number of apprentices. They, however, have agreed that in future apprentices shall be bound. This has been accepted by the men, and a strike has been averted.

**BRADFORD.**—A deputation from the Leeds Society of Joiners have attended a meeting of Bradford joiners, who are on strike, to consider the action of the Bradford masters in, as it is alleged, inducing Leeds employers to stop men who, since the commencement of the dispute, have left Bradford and obtained work in Leeds. As a result of the conference it is stated the Leeds men will take action if that course of conduct is persisted in by the masters.

**LEEDS.**—Some months ago the operative plumbers of Leeds intimated to their employers that they required an advance of wages to the extent of 1d. per hour, together with considerable alterations in the working rules. They have been receiving 8d., and they wanted 9d. In the interval the masters have endeavoured to effect a compromise by offering 8½d. per hour, but have so far failed in their object. The men insist on 9d., and for the further consideration of the matter a meeting of the local branch of the Master Plumbers' Association was held on Friday night, Mr. John Skirrow, president, in the chair. There was a numerous attendance, and the question was once more fully discussed. The result was the confirmation of the decision to offer an advance of ¾d. per hour. Sheffield, it seems, is the only town in the county in which the plumber is paid 9d. per hour, and that being so, the Leeds employers feel that if they conceded 9d., whilst adjacent towns, such as York, Bradford, Halifax, Huddersfield, and Dewsbury, were continuing to pay less, they would be subject to unfair competition, inasmuch as a considerable proportion of the work now undertaken by Leeds shops is beyond the city boundaries. The representatives of the men, on hearing the masters' decision, plainly indicated that it is the intention of the operatives to come out on strike when their notice terminates—viz., to-day (Friday)—unless their terms are granted. The masters' organisation comprises 60 shops, and all the larger ones; the operatives concerned number between 300 and 400.

**NEWPORT.**—The dispute between the Newport Master Builders' Association and the carpenters' societies, which resulted in the men being locked out before Easter, shows no signs of being settled. The masters during the last few days have abandoned the lock-out and have thrown their shops open. The men, however, desire a settlement of the overtime question, over which the dispute originated; but up to the present the masters have declined to consider the matter, and have attempted to fill their shops. The attempt has not met with success up to the present. Efforts are being made to bring the parties together again for a fresh conference.

**WREXHAM.**—The operative carpenters and joiners of Wrexham recently asked an advance in the standard rate of wages, and the request has now been generally granted. The men have received an increase of one halfpenny per hour from 24 of the largest firms. The united committee of the men have issued a circular thanking the employers for their consideration, and assuring them that the men intend to give to the masters an ample return for the increase.

**YORK.**—No change is reported in the dispute regarding the York carpenters and joiners and their employers. Building matters in the city are practically at a standstill so far as carpentering is concerned. The dispute is resolving itself into a contest of endurance, and who will last the longer has yet to be seen. The York and District Trades Council have resolved to support the men "morally and financially."

A new peal of bells, which have been erected in the tower of All Saints Church, Northalerton, was dedicated on Friday. The old peal of bells were taken down, two new bells being added, and the remaining six returned.

At the Oxford Encenia, on the 22nd inst., honorary degrees of D.C.L. will be conferred upon Mr. F. C. Penrose, F.R.S., ex-president R.I.B.A. and late surveyor of St. Paul's, and on Sir J. Scott, K.C.M.G., late Judicial Adviser to the Khedive of Egypt, and Sir E. J. Poynter, P.R.A., Director of the National Gallery.

## CHIPS.

Sir J. Wolfe Barry, K.C.B., and Professor Roberts-Austen, C.B., who are members of the committee appointed by the Government to report on the advisability of establishing a national physical laboratory in this country, have left London for the Continent to inspect the Reichanstalt and other technical institutions in Berlin.

A Primitive Methodist chapel in St. Albans-road, Watford, was formally opened on Wednesday week. The building is faced with Fletton red bricks, relieved by Bath stone dressings, the constructive timbers are of Baltic red deal, the whole of the internal joinery being of pitch-pine. The greater part of the congregation is provided for on the ground floor, and a small portion in an end gallery. The accommodation is for 460 persons. The estimated cost, exclusive of land, is £1,650.

Ayscoughgee Hall and Gardens at Spalding, acquired by the town as a place of public resort to celebrate the Queen's Jubilee, were opened on Whit Monday by Mr. H. F. Pollock, M.P. The initiative was taken by the Spalding Urban District Council, and the property has been obtained at a cost of £2,150.

The late Mr. Philip H. Calderon, R.A., who died on April 30, leaves gross estate sworn at £6,168 7s. 1d., the net personality being £6,013 15s. 8d. The sole executrix of his will is his widow, Mrs. Clara M. Calderon, of Burlington House.

Among the increases of salary granted by the London County Council at the last meeting were the following:—J. Briggs, architect's department, from £325 to £500 by annual instalments of £25; H. Becher, bridges department, from £350 to £400 by two instalments; F. W. Cook, estates clerk, valuer's department, from £350 to £500 by instalments of £25; and W. Garnsey, chief clerk, from £350 to £400 by two instalments; G. Wise, principal assistant, works department, from £300 to £400 by two annual instalments of £50.

The commissioners who recently held an inquiry at Beaumaris touching the proposal for the construction of a light line of railway between Llanfair P.G. and Beaumaris have refused to advise the Board of Trade to grant a provisional order.

The parish church of St. Laurence, Meriden, has just had another point of interest added to its treasures in the shape of a chained book, which was given to the church with an oak chest in 1627. The old Legier Book is a collection of the works of Bishop Jewel, who was Bishop of Salisbury in Elizabeth's reign. The binding has been repaired, and the original chain now attaches it to a desk.

At Marylebone Police-court on Monday, Thomas Lewis, 32, operative painter, was remanded charged with the murder of Walter Gibbs, a house decorator, who died on Saturday morning from injuries alleged to have been inflicted by the prisoner in a fight outside a publichouse in North-street on Friday afternoon.

The Lord Chancellor opened at Farnborough, Hants, on Tuesday, a public hall given to the people, at a cost of several thousand pounds, by Major and Mrs. Holt, in commemoration of her Majesty's Diamond Jubilee.

The Local Government Board have appointed Mr. Jas. Green, of the firm of Weatherall and Green, to be the surveyor under the County Council Improvement Act, 1897, to settle the value of properties within the improvement areas in connection with the Tottenham Court-road and Strand widenings, where it is contended that "betterment" will result.

An outbreak of fire occurred on Monday afternoon at the timber-yard of Messrs. Garland and Roger, situated at the north-east corner of the Edinburgh Dock, Leith. The damage done exceeded £2,000.

The clearance of the Carrington House site begins immediately, and H.M. Office of Works will migrate to Storey's-gate, St. James's Park, shortly, in order to place their present building at the disposal of the wreckers.

A new Congregational chapel and schools are in course of erection in Dacre-street, Morpeth. Mr. T. W. Middlemiss, in commencing excavations for the foundation has come across two large boulders imbedded in the gravel soil, one of limestone weighing between two and three tons, and the other of whinstone weighing not less than twelve tons.

At Hereford a Jubilee footbridge is being thrown across the Wye at the Castle Green. The bridge will rest on two piers in the river, with a central span of 110ft., and will be of concrete and iron. The cost will be £1,200, and Messrs. Findlay and Co., of Glasgow, are the contractors for the ironwork.

The painted copies of the celebrated Raphael cartoons, intended for the Cathedral at Lima, are now nearly finished by Mr. Calderon, and the four last may be seen in the Raphael Gallery at South Kensington Museum.

**CHIPS.**

A children's wing has been added to the hospital at Lowestoft, from plans by Mr. W. J. Roberts, architect, of that town.

The Bishop of Chichester on Sunday consecrated the church of St. Philip, Aldrington, near Hove.

The members of the Society of Architects will make an excursion to Windsor on Saturday, the 18th inst.

Scarborough Unitarian Church, which has been closed for some weeks, was reopened on Sunday last. The church has been cleaned and painted, a new organ erected, and the electric light installed. In addition to this, some fresco decorations have been painted upon the end wall, each recess or niche containing a figure upon a dull gold background. The figures illustrate the cardinal virtues, Faith, Love, Hope, Peace, &c. The work has been executed by Messrs. Powell Brothers, of Park-square, Leeds, under the supervision of Mr. T. W. Cannon, architect, of Leeds.

During a violent thunderstorm at Dartford on Tuesday evening, a flash of lightning struck the tower of the parish church and caused damage estimated at £300. The tower is the oldest part of the church, and was formerly a fortification, built upon some Roman foundations.

Abercorn Park, which the public parks committee have acquired for the Portobello district of Edinburgh, was opened on Saturday afternoon. The grounds have been laid out under the direction of Mr. McLeod, the city gardener.

The Bishop of Chichester opened on Friday the Simmons Church Institute at Seaford. The building seats 150 persons in the large hall, which is 40ft. by 20ft., with a 30ft. apse. The whole is inclosed with a fence. The building cost £1,000, which has been defrayed by Mr. Henry Simmons, who also gave the site. The architect was Mr. H. Curtis Card, of Lewes, and the builder Mr. C. Morling, of Seaford.

The Leeds City Council agreed on Wednesday to allow another £5,000 to be expended on the experiments in the bacteriological treatment of sewage at Knostrop.

Arrangements are in progress for converting the buildings at present occupied by the Aske's Schools at Hoxton into a technical institute and technical day-school specially suited for equipping pupils for the furniture and cabinet-making trades of the district. The Shoreditch Municipal Technical School will be transferred to these buildings after the summer holidays. The boys in the day technical school will have the advantage of the use of the workshops in the daytime. The day-schools for boys and girls, which are at present located at Hoxton, will be transferred to Hampstead and Acton respectively.

The Independent Methodists at Salem Chapel, Scotland-road, Nelson, have resolved to erect a new school-chapel, which will have accommodation for about 500 adults. The building will cost over £3,000. Two new school-chapels are about to be erected by the Nelson Wesleyan circuit, one in Barkerhouse-road and the other in a neglected part of the town. Accommodation will be provided for 700 persons in each place, and the cost for each is estimated at over £4,500.

A board school, accommodating 509 children, and built at a cost of £4,000, was opened at Allerton-Bywater, near Castleford, on Friday.

The parish church of Craiglockhart, N.B., was reopened on Sunday after restoration from plans by Messrs. Hay and Henderson, architects, of Edinburgh, from whose designs a tower is being added to the building. The style of the new works is Scottish 15th century.

A very satisfactory report has been received by the Unhealthy Dwellings Sub-committee of the Manchester Corporation in regard to the occupation of the Corporation dwellings in Oldham-road and Pollard-street, which were erected under the Artisans and Labourers' Dwellings Act. These two blocks of buildings were completed and ready for occupation in the middle of 1894. At first there was a strong prejudice amongst the labouring class in regard to the occupation of buildings of this description, but this died away during 1896, and the committee are now enabled, in consequence of the large number of applications for tenements, to refuse any applicants whose character may not be satisfactory. On two occasions within the last few weeks the whole of the shops and tenements have been occupied, and the number of empty tenements in either block of buildings will not average more than three per week.

Mr. Walter A. Ducat, Local Government Board Inspector, held an inquiry at Devonport, on Friday, respecting an application of the town council for leave to borrow £9,250 for the purchase of a site for municipal buildings. The site adjoins the South-Western Railway station and the technical school in course of erection.

The new schools, Taunton, are being warmed and ventilated by means of Shorland's patent Manchester grates, the same being supplied by Messrs. E. H. Shorland and Brother, of Manchester.

The Baptist church at Pietermaritzburg was crowded yesterday afternoon, says the *Natal Witness* of April 28, on the occasion of the solemnisation of the nuptials of Mr. William Hems, third son of Mr. Harry Hems, the well-known ecclesiastical sculptor, of Fair Park, Exeter, Devon, and Florence Isabel, only daughter of Mr. Wm. Loney, of Maritzburg, and formerly of Wellington, Somerset. Among those present was Mr. Harry Hems, who came specially from England to attend the marriage.

The Kent and Surrey Committee of the Commons Preservation Society are to be congratulated on the acquisition of "the highest point in Kent," a piece of land at Toy's Hill, from which the famous view over the Weald of Kent is obtained.

A faculty has been granted by the Consistory Court of Manchester for the restoration of St. Paul's Church, Bury, the work to include the removal of the north and south galleries. The architect is Mr. C. H. Openshaw, of Fleet-street, Manchester.

The great tower at New Brighton, which has been in process of construction for nearly two years, was opened to the public on Whit-Monday. In the lower portion of the structure are a theatre, a ball-room, a winter garden, restaurant, cafés, and shops. The work of erecting the tower and laying-out the grounds has cost over £400,000, and has been executed from designs by Messrs. Maxwell and Tuke, of Manchester and Bury.

A conversazione of the Institution of Civil Engineers was held on Friday night at their house in Great George-street. The programme included an exhibition by Captain Abney of Dr. Joby's photography in natural colours, of views illustrating the total solar eclipse in January last, and of engineering models and scientific apparatus, and electric-lighting methods of the present and of a bygone day.

The memorial stone of a new church for Cuninghame Free Church congregation, Glasgow, was laid, on Saturday afternoon, by Mr. A. Cameron-Corbett, M.P. The new church is situated at the corner of Govan-street and Thistle-street, and is a plain structure, without steeple or tower. Sittings are to be provided in the church for 870 persons; and the halls, with church-officer's house, form three stories, and give accommodation for 900 children. The old church has been acquired by the Glasgow and South-Western Railway Company for £9,000, and the cost of the new buildings is £8,000.

The memorial-stone of a new chapel about to be added to Queen Anne's School, Caversham, near Reading, was laid on Wednesday week. The school was till recently known as Amersham Hall, but has been converted into a country branch school for girls of the Grey Coat Hospital, Westminster. The chapel, which is now in course of erection, is to be of red brick, with stone dressings. It will be 70ft. by 30ft., and has seating accommodation for over 200 persons. The estimated cost is £3,000. The building is in the Late Decorated style. There will be a raised chancel, and the floor will be paved with wood blocks. The roof will be open-timbered, covered in with slates. The work is being carried out by Messrs. Lewis Brothers, builders, Reading, from designs by Sir Arthur Blomfield, A.R.A., and Sons, architects. Mr. Roberts is clerk of the works.

**LATEST PRICES.**

IRON, &c.		Per ton.	Per ton.
Rolled-Iron Joists, Belgian.....	26 0 0	to	£8 10 0
Rolled-Steel Joists, English.....	6 10 0	"	7 0 0
Wrought-Iron Grid Plates.....	5 15 0	"	6 10 0
Bar Iron, good Staffs.....	7 0 0	"	8 0 0
Do., Lowmoor, Flat, Round, or Square.....	17 0 0	"	17 5 0
Do., Welsh.....	5 15 0	"	5 17 6
Boiler Plates, Iron—			
South Staffs.....	7 17 6	"	8 5 0
Best Snedshill.....	10 0 0	"	10 10 0
Angles 10s., Tees 20s. per ton extra.			
Builders' Hoop Iron, for bonding, &c., £6 15s. od. per ton.			
Builders' Hoop Iron, galvanised, £15 10s. od. per ton.			
Galvanised Corrugated Sheet Iron—			
No. 18 to 20.	No. 22 to 24.		
6ft. to 8ft. long, inclusive gauge.....	Per ton.	Per ton.	
Best ditto.....	£10 15 0	£11 0 0	
	11 5 0	11 10 0	
	Per ton.	Per ton.	
Cast-Iron Columns.....	£6 0 0	£8 10 0	
Cast-Iron Stanchions.....	6 0 0	8 10 0	
Rolled-Iron Fencing Wire.....	7 0 0	8 0 0	
Rolled-Steel Fencing Wire.....	7 6 0	7 10 0	
Galvanised.....	10 10 0	11 10 0	
Cast-Iron Sash Weights.....	4 0 0	4 2 6	
Cast-Iron Socket Pipes—			
3in. diameter.....	5 10 0	5 15 0	
4in. to 6in.....	5 5 0	5 10 0	
7in. to 24in. (all sizes).....	4 15 0	5 0 0	
[Coated with composition, 2s. 6d. per ton extra; turned and bored joints, 6s. per ton extra.]			
Pig Iron—		Per ton.	
Cold Blast, Lilleshall.....		105s. to 110s.	
Hot Blast, ditto.....		57s. 6d. to 62s. 6d.	
Wrought-Iron Tubes—Discount off Standard Lists f.o.b.			
- Gas-Tubes.....	75p.c.	Fittings 77½p.c.	
Water-Tubes.....	70	72½	
Steam-Tubes.....	62½	65	
Galvanised Gas-Tubes.....	60	62½	
Galvanised Water-Tubes.....	55	57½	
Galvanised Steam-Tubes.....	45	47½	
10cwt. casks. 5cwt. casks.			
Sheet Zinc, for roofing and working up.....	£22 10 0	to	£23 10 0
Sheet Lead, 3lb. per sq. ft. super.....	15 10 0	"	16 10 0
Pig Lead, in lwt. pigs.....	15 0 0	"	16 0 0
Lead Shot, in 25lb. bags.....	17 10 0	"	18 10 0
Copper Sheets, sheathing and rods.....	63 10 0	"	64 10 0
Copper, British Cake and Ingot.....	51 15 0	"	52 15 0
Tin, Straits.....	67 12 6	"	68 12 6
Do., English Ingots.....	69 15 0	"	70 15 0
Spelter, Silesian.....	18 0 0	"	19 0 0
Cut Clasp Nails, 3in. to 6in.....	8 15 0	"	9 15 0
Cut Floor Brads.....	8 10 0	"	9 10 0
Wire Nails (Points de Paris).....			
0 to 7 8 9 10 11 12 13 14 15 B.W.G.			
8/6 9/0 9/6 10/3 11/0 12/0 13/0 14/9 16/9			per cwt.

TIMBER.		per load	£13 0 0	to	£14 0 0
Teak, Burmah.....		9 0 0			13 15 0
" Bangkok.....		2 5 0			4 5 0
Quebec pine, yellow.....		3 15 0			5 0 0
" Oak.....		2 16 0			4 7 6
" Birch.....		4 0 0			5 0 0
" Elm.....		3 5 0			4 10 0
" Ash.....		2 2 0			3 2 0
Dantsic and Memel Oak.....		1 4 0			3 4 0
Fir.....		5 0 0			6 10 0
Wainscot, Riggs P. log.....		4 10 0			5 10 0
Lath, Dantsic, p.f.....		5 0 0			6 10 0
St. Petersburg.....		8 0 0			8 10 0
Greenheart.....		4 0 0			15 0 0
Box.....		0 1 8			0 1 10
Sequoia, U.S.A., per cube foot					
Mahogany, Cuba, per super foot					
lin. thick.....		0 0 5			0 0 6½
" Honduras.....		0 0 4½			0 0 5
" Mexican.....		0 0 4			0 0 5
Cedar, Cuba.....		0 0 4			0 0 4½
" Honduras.....		0 0 3½			0 0 4
Satinwood.....		0 0 5			0 1 0
Walnut, Italian.....		0 0 3			0 0 7
Deals, per St. Petersburg Standard, 120—12ft. by 1½in. by 1½in.					
Quebec, Pine, 1st.....	£19 5 0	to	£25 5 0		
" 2nd.....	13 5 0	"	16 5 0		
" 3rd.....	6 5 0	"	9 15 0		
Canada Spruce, 1st.....	10 10 0	"	12 0 0		
" 2nd and 3rd.....	8 0 0	"	9 0 0		
New Brunswick.....	7 0 0	"	8 0 0		
Riga.....	6 15 0	"	7 15 0		
St. Petersburg.....	8 15 0	"	12 15 0		
Swedish.....	9 5 0	"	15 15 0		
Finland.....	8 5 0	"	8 15 0		
White Sea.....	9 15 0	"	16 5 0		
Battens, all sorts.....	5 0 0	"	18 0 0		
Flooring Boards, per square of lin. —					
1st prepared.....	£0 9 6	"	£0 17 9		
2nd ditto.....	0 8 0	"	0 13 6		
Other qualities.....	0 6 0	"	0 7 0		
Staves, per standard M:—					
Quebec pipe.....					
U.S. ditto.....	£35 0 0	"	£42 10 0		
Memel, cor. pipe.....	220 0 0	"	230 0 0		
Memel, brack.....	190 0 0	"	200 0 0		
<b>OILS.</b>					
Linseed.....	per ton	£17 0 0	to	£17 10 0	
Rapeseed, English pale.....		24 10 0	"	25 10 0	
Do., brown.....		23 10 0	"	24 0 0	
Cottonseed, refined.....		16 5 0	"	16 15 0	
Olive, Spanish.....		32 10 0	"	33 0 0	
Seal, pale.....		21 0 0	"	21 5 0	
Cocconut, Cochin.....		28 0 0	"	29 10 0	
Do., Ceylon.....		24 0 0	"	24 10 0	
Palm, Lagos.....		23 5 0	"	23 10 0	
Oleine.....		18 15 0	"	19 15 0	
Lubricating U.S.....	per gal.	0 6 3	"	0 7 6	
Petroleum, refined.....		0 0 4½	"	0 0 4½	
Tar, Stockholm.....	per barrel	1 0 0	"	1 5 0	
Do., Archangel.....		0 12 6	"	0 15 0	
Turpentine, American.....	per ton	23 15 0	"	24 0 0	

**W. H. LASCELLES and Co.,**  
 121, Bunhill Row, London, E.C.  
 TELEPHONE No. 270.  
**HIGH-CLASS JOINERY.**  
**LASCELLES' CONCRETE.**  
**Conservatories & Greenhouses.**  
**WOODEN BUILDINGS.**  
**BANK, OFFICE, & SHOP FITTINGS.**  
**CHURCH BENCHES & PULPITS.**  
 ESTIMATES GIVEN ON APPLICATION.  
**IS THE ELECTRIC LIGHT REALLY DEARER THAN GAS?**  
 A large number of replies to the above query from actual users will be sent post free on application to the  
**COUNTRY HOUSE SPECIALISTS,**  
**Messrs. DRAKE & GORHAM,**  
 66, VICTORIA STREET, WESTMINSTER, LONDON, S.W.

LIST OF COMPETITIONS OPEN.

Table listing competitions open, including locations like Castletown, East Ham, Rotherham, and various building types such as Sewerage Works, Public Offices, and Schools. Includes names of officials and dates.

LIST OF TENDERS OPEN.

BUILDINGS.

Large table listing tenders open for various buildings across different locations. Columns include building name, location, and the name of the architect or contractor.

# THE BUILDING NEWS

## AND ENGINEERING JOURNAL.

VOL. LXXIV.—No. 2266.

FRIDAY, JUNE 10, 1898.

### KEEPING PACE.

**T**HE hurry and rush of professional life at the present day is, perhaps, one of the chief impediments in the way of great achievements. One of the speakers at the Architectural Association Dinner remarked it was a serious matter nowadays to organise and keep going societies; and the same kind of remark applies in a much greater degree to the lack of time and opportunity to keep pace with the advance and growth of industries and the science of the architect's calling. If we consider the immense amount of collateral knowledge now required to equip a man to practise as a competent architect, and the very little time afforded him in a business that must be pushed and kept going, we shall soon realise how hopeless it is for anyone to take to the profession who is not addicted to sustained effort and hard work. A young man who loves his leisure, but who at the same time has a love for art—and there are many such—has little opportunity of making architecture remunerative. The overwhelming number of matters that now call for immediate solution, the mastering of details of trades, many of which are of comparatively new introduction, such as the different systems of hydraulic foundations, the demands of steel, of fireproof construction, of electric lighting, of heating apparatus, and other questions, almost render it impossible for an architect to spend much time over these subjects in the way of thinking over features, of elaborating his thoughts or details. No doubt the inability of one man to master his art in all its branches, and to thoroughly understand executive details necessary for carrying them into execution, has furnished some ground for dividing the work of the profession—of employing those who are not hampered by the anxieties of practice to prepare the design, leaving to practical men the usual professional duties; but the objection to this division of labour is that designs made apart from the real condition of materials and progressive workmanship are wanting in that true interdependence between labour and art so necessary to success. And the man who works independently of his material falls into platitudes and mannerisms to a greater extent than one who is in touch with the actual requirements of building. We speak now of the hurried way the architect is compelled to carry on his work; how impossible it is for him to consult any authorities or precedents, to make the necessary arrangements for trades which are absolutely called for, and the consequent unpreparedness with which he enters into any of those numerous details he is called upon to deal with. It is important for him to closely watch the market, to see what new things have come out in the way of ironmongery, of metal-work, decorative and other materials; any inventions in sanitary fittings, heating, electric-lighting, &c. The exhibition and the trade catalogue must both be in evidence; he cannot afford to indulge in cheap sneers at Mr. Smith's taste for iron grates and overmantels or electric fittings when any decided improvement has been made in construction. An exhibition such as that of building appliances or art metal-work may teach him many things that he could never learn by studying an old treatise or a book on art-metal, and a great deal must be learned from trade catalogues and chats with manufac-

turing firms. He must have a mind and eye open for picking up sundry things connected with his vocation, and probably the most successful man is he who, in this omnivorous manner, is the picker-up of various unconsidered trifles, and who can appropriate them to his particular work. Take, for example, many things met with in such an exhibition as that of art metal-work open at the Royal Aquarium. An architect who is about to design or specify any iron or metal-work will do well to acquaint himself with the many new forms and sections of cast-iron and bar-iron that are in the market. Suppose he is looking for a water-tight metal casement, he will see dozens of examples of improved casements and frames fixed to jambs and mullioned windows, or if he is in quest of artistic patterns for handles or finger-plates, or electric fittings, he will find many of considerable merit in the collection. One thing we learn from a visit to an exhibition of this kind is the immense strides that have been made in cast work and wrought iron hammered work during the last decade or two;—how many new forms and applications of metal have been made for building, how varied are the wrought steel and iron sections for window frames and sashes; how hammered iron, bronze, aluminium, copper, and other metals can be turned to account for decorative uses, for joinery and furniture, which a few years ago were unknown. Other specialties of construction demand a constant "looking-up." What with tests of brickwork, and iron, and concrete, and the new developments of fire-resisting construction in its many forms of floors and roofs and coverings, the architect must be always taking in and digesting. Such a special branch of construction as stage architecture and machinery, requiring a particular study of theatres and operahouses, is a matter quite of recent years. The costly and valuable contributions of Mr. Edwin O. Sachs on this branch alone require careful study. The machinery of the stage, and of other forms of complex buildings like big hotels, club-houses, and residences, require a more intimate knowledge of iron and steel construction, hydraulic power, electric motors, and other things, than has hitherto been thought of. Even the comprehensive list of attainments which Vitruvius laid down as necessary for the architect of his day, is quite small if we compare the few abstract principles known in his time which passed for sciences with the numerous special developments of experimental science, any of which would require years to thoroughly master. For it is not so much the abstract and simple principles, but the application of science to building in its varieties, that has to be mastered. The minutiae of the trades, prices, and legal matters keep a busy practitioner pretty well occupied. The purely artistic must necessarily be left in the rear. Were it not for the artistic gifts which seldom fail their possessor, and his early training and culture in art, it would be quite impossible for an architect in these days to add anything to his store of ideas, and it is because of this, that we think the historical and the artistic parts of his equipment should be learned or cultivated early in the career of the young architect. Happily, there are many agencies for instruction outside the classroom and the elementary studio or workshop. We have named some of them, exhibitions of art and technological products, the lectures and illustrations of professional societies, all of which find a place in the technical press, which can be relied upon by the provincial business man and student. But is not the hurry of the modern architect's work answerable for thoughtless architecture and inferior construction? The best has always been the product of ages when the range of attainments was limited, and there was no haste.

### FRENCH PAINTINGS AT THE GUILDHALL.

**T**HE Corporation of the City have this year brought together in their Art Gallery a very interesting loan-collection of French pictures, which illustrate the progress of painting during the last 200 years or more. The earlier pictures are those in Gallery II., where we find one of Antoine Watteau's finest works, "La Gamme d'Amour," vivacious in drawing and rich in colour. It is a small picture of eight figures in a garden; a lady and gentleman in the foreground, the latter playing on a mandolin, while the lady seated on the ground beside him holds the music-book open. Beyond is a group of other figures. This picture is well known from an engraving by Le Bas. Watteau's attractiveness is a certain grace and freshness in depicting the society of the early 18th century, and his subjects are pastoral festivities, music, and dance. "A Garden Scene" (51)—figures in a garden, a gentleman in red playing a guitar to a lady in white who sits at his side, playing with a spaniel, a child at her feet, is also a pleasing little picture. A very charming and brilliant little piece, "The Duet" (53), only 7in. by 6in., lent by Sir Francis Cook, Bart., represents a man and woman singing by candle-light, the light falling on the music-book. Next we have a work by J. B. Greuze, also small, lent by Lord Wantage, "A Girl with a Young Bird," an exquisite work, full of grace, movement, and tenderness. "Marie Antoinette and her Children," by Madame le Brun, a small panel, depicts the beautiful and unfortunate wife of Louis XVI. as she was before the disastrous Revolution to which she fell a victim. Her three children are in the group. Another brilliant Watteau is 71, "A Fête Champêtre," a garden or wood full of figures; one couple is dancing to pipers, and a lady in white satin and pink cloak and two children are looking on, while others are coquetting. Works attributed to De la Haye, "A Lady and Gentleman Playing Cards" (50), is Dutchlike in its quality and finish. Further on we have a large full-length portrait of the Duc de Penthièvre, in a grey costume, with black hat in his hand. An attendant is divesting the Duke of his embroidered cloak. The delicate silver grey and the scarlet livery of the stooping servant, the couch of pale blue and gold, make a very harmonious scheme of colour. It is painted by J. M. Nattier, a great portrait artist, who died in 1766. Lord Wantage's Lancret, "A Garden Party" (84), is a fine work, with much of the Watteau style, but quieter. The group of figures, especially the children; and landscape, are delightful. "The Swing" (78) is another interesting example. Mr. Alfred de Rothschild's works by Boucher, such as "Cupid and Children" (85), "A Group of Children" (74), are good examples. But for the general picture-admirer the canvases of the large gallery are the most attractive. What can be finer than the "Solitude," by H. Harpignies?—a sunset landscape with the reflected light on the winding river between wooded banks. The "Funeral of a Chief in the Iron Age," by Fernand Cormon, exhibited in the Paris Salon of 1892, we have seen before. Amidst a crowd of savages armed with weapons, the burning of the funeral pile is going on; the very clever picture "Execution of Marshal Ney after the Defeat at Waterloo," by J. L. Gérôme, is also here. G. Laugée Fil's picture of "The Widow" (4) is feelingly painted. The fine example of Bastien-Lepage, "La Saison Octobre," or the "Potato Harvest," is worth looking at again—women and girls in a field filling sacks with potatoes—a powerful work of the best realism. Meunier's picture, "The Emigrants," an old man and his daughter

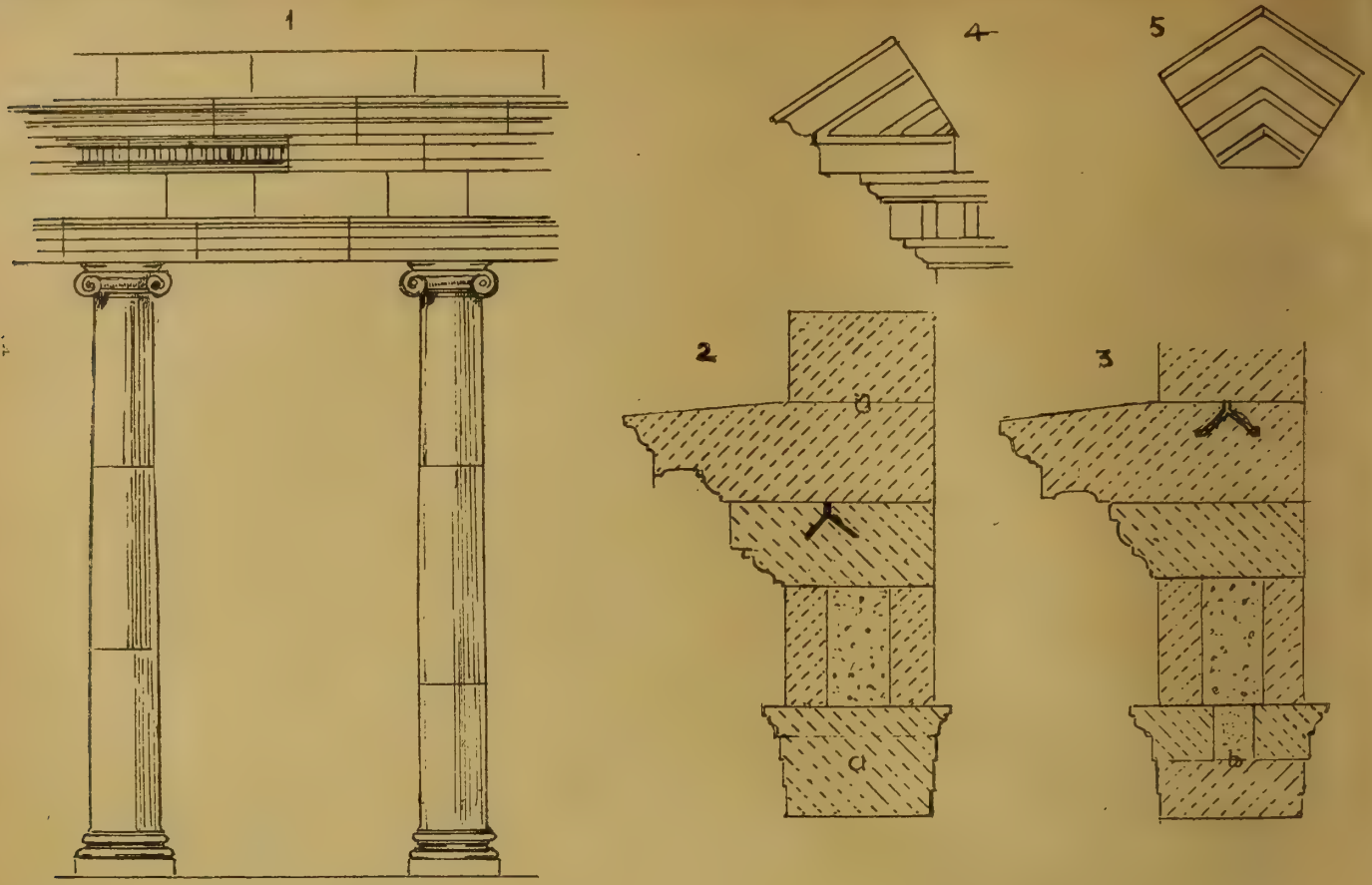

Entablature

trudging along a sandy road, with their belongings, is full of pathos and tenderness of expression. A very fine work by C. F. Jalabert, "Christ Walking on the Sea" (12), lent by H.R.H. the Duchess of Albany, will attract attention. The scene illustrates the narrative of Mark vi. 48, where our Saviour appears to the affrighted crew in the fourth watch of the night. The luminous and radiant figure of the Saviour is dignified and mystically realised. The very large seascape "A Rescue at Sea from a Burning Vessel," by A. Morlon, lent by the painter, is a very effective piece of sea-painting; the blazing hull of a large vessel is seen in the distance amidst a tempestuous sea, while a boat full of the picked-up crew is trying to save a man, who clings to a floating spar, by throwing a life-belt to him. A very choice piece of flower-painting is E. Bidau's charming group of white and pink roses and playful kittens (14). Jean Béraud is seen at his best in "Réunion à la Salle Grafford," where an audience of enthusiasts shout hoarsely "Vive La Commune!" The galleried hall is crowded with Communists of the most fanatical type; one wild-looking man on a platform by the side of the chairman holds up his large hand, and in wild gesticulation is haranguing his colleagues. The characters are drawn from life, and the scene is full of animation. Jules Breton's "The First Communion," a procession of young girls clad in white carrying tapers, breathes of the poetry of human life. One little girl is being kissed by her mother on her way. A fine example of F. Roybet, "La Sarabande," is a large and prominently-hung picture at the end of gallery. The principal figures—a gentleman playing a mandolin, his young wife seated beside him, in pale-blue silk, while two children—a boy and girl—are stepping to a dance, is graceful and brilliant in colour. On the other wall the colossal picture of "Friedland," by J. E. Meissonier, well known from the etching by Jacquet, published by Arthur Tooth and Sons, hangs, a marvellous example of movement and expression. The scene illustrates the French army, commanded by

Napoleon, about to meet the Russian forces, 14th June, 1807. The Emperor, with his generals around him, is looking on at the dashing cavalry regiment, which is sweeping past him through a mass of thick grass. Each horse and rider is made a study, and the eye is struck as much by the breadth and skill of the massing as by the extreme finish and detail. "A Reconnaissance," a painful incident in the siege of Paris, by Edouard Detaille, is another work of infinite care and skill. E. Burnand's "Return of the Prodigal" (27), Dagnan-Bouveret's "Bretonnes au Pardon," a clever group of nuns seated on the grass are interesting works. The sensational but clever picture by Albert Maignan, of the "Death of William the Conqueror," and the touching and beautiful repose of a young girl lying dead, "Une Bienheureuse" ("The Sleep of the Blessed Dead"), are pictures of merit. The fine work by J. L. Gérôme, "The Cardinal in Grey," a grand staircase scene, where the barefooted Capuchin is descending a noble flight in the Old Palais Cardinal, while a servile crowd of courtiers are ascending on one side, bowing low, and after they pass on the upper flight are seen to look round at the cardinal in an insolent manner, is a clever piece of irony. "La Salutation Angelique," by Guillaume Dubufe, is decorative; and we must notice also J. Tissot's "Too Early," a piece of amusing *genre*, and his touching "Last Evening" (45); Fantin-Latour's flowers (43A), "Cupid and Psyche," G. W. A. Bouguereau. In the second gallery is a fine work by Corot, "Le Lac," a beautiful lake scene, the tone and softness of the colour and foliage exceedingly beautiful. In the third gallery, a little work of much value, "Fainting of the Virgin" (141), by Paul Delaroche, is full of devotional feeling; and we must also notice a work by Armand Charnay, very charming and delicate in colour; and some clever figure-subjects. Meissonier (132, 134), portrait of Madame Gautreau, by G. Gustave Courtois, and pictures of Carolus Duran, Gustave Courbet

(143), a delightful sandy shore—a harmony of greys; E. Degas, Cazin, Monet, J. Renoir, and other well-known French painters. The latter's "A Cup of Tea" (150) is a daring piece of colour.

#### MODEL SPECIFICATIONS.—XVI.

MASON.

IN the specification of finished Classical work particular care is necessary. We now give clauses for the execution of columns, entablatures, and pediments. In specifying these features, the bases, shafts, capitals, entablatures, the jointing, dowels, and cramps ought to be described unless the drawings show these details. As to columns, it is not usual in Classic architecture that the ashlar joints are continued through the shafts; they may be, if of considerable height, of three or more stones. For example, in the Strand front of Somerset House, which is before us as we write, the columns (three-quarter) above the ground story are about 18ft. or 20ft. in height of shaft, and have three stones or frustra between base and capital. The lowest stones are the shortest, the two upper ones being about equal height, or 7ft. in length each. The base and capital are, of course, separate stones, and their bed-joints course with the ashlar. The shafts are, as usual, diminished, and the small curves or apophyses joining the upper fillet of base and the lower fillet of the neck of capital are included in the base and capital respectively, not worked on the shafts. When they are so worked, the cylindrical shaft has to be sunk to the full projection of the fillet—an undesirable and uneconomical plan, though it may look a little better if the bed-joint is placed below the upper fillet of the base. Columns of three-quarter projection may be dowelled at the beds, or preferably bonded at intervals. In lofty columns the stones should be bedded upon 4lb. lead, about an inch within the face of shaft. Sometimes thin laminae of pine are used instead of lead, and these seatings prevent flushing at the joints, and equalise the pressure. For



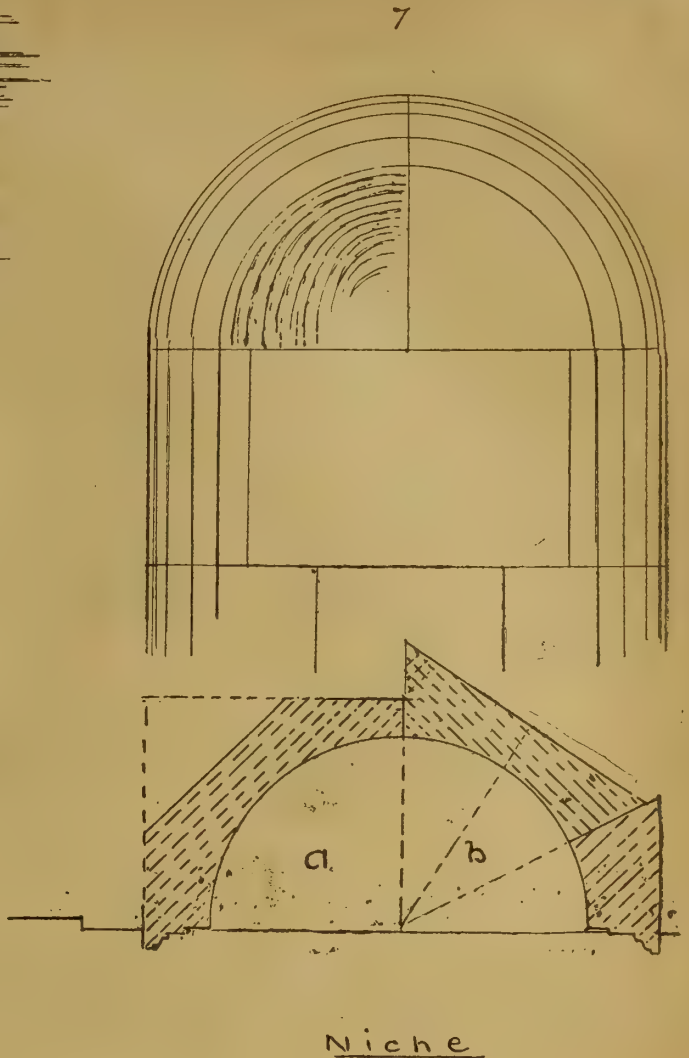
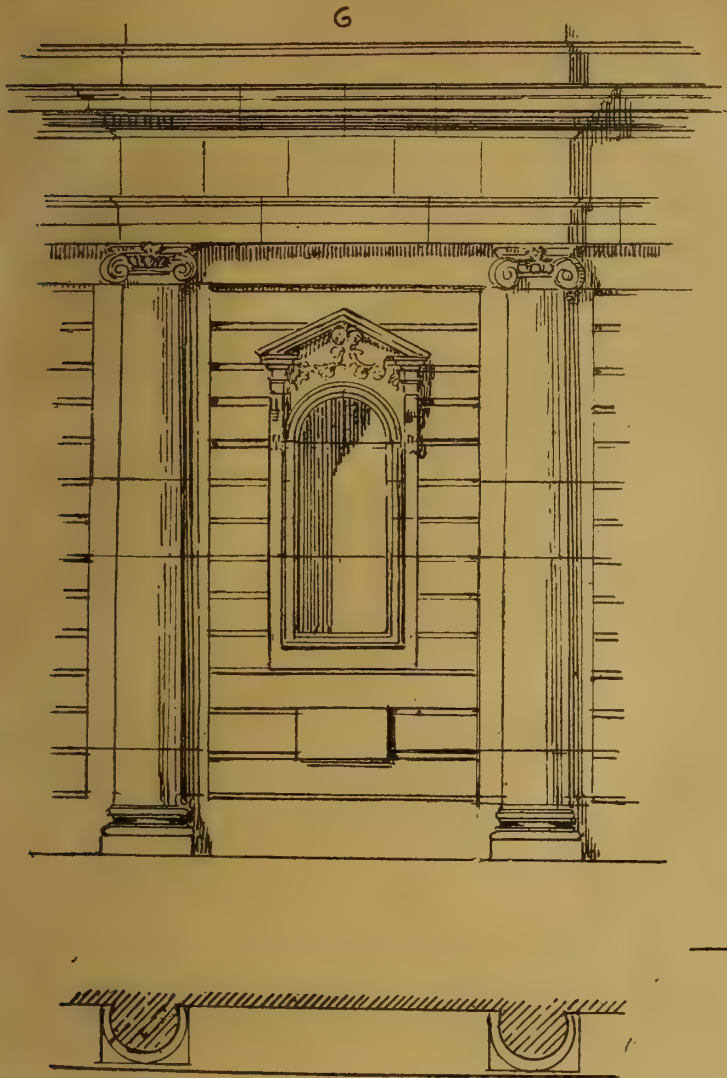

bedding, stone-dust mortar is sometimes used. The joints should be few and fine; the stones of the frustra for each shaft should be selected. Vertical joints are wrong, though they are seen occasionally in Continental buildings. The beds or ends of each stone should be worked to exactly true and parallel planes, and the sides of column or each stone be worked to a diminishing rule.

The distance apart of the columns must determine the number of stones or joints of the entablature over. When the columns are engaged, as in the building mentioned, the architrave can be partly supported on its inner side by the stones tailing into the wall; but when the entablature is isolated, as in a portico or colonnade, proper means must be taken to insure support if the intercolumnar spaces are wide. Rondelet and other French writers describe the tying together of the stones by rods and bars. In ordinary cases, where the columns are three or more diameters apart, the distance may be spanned by three stones, the centre one, or "key-stone" being joggled to the other two which rest on the columns. But, of course, the quality of stone used, and whether it can be obtained solid in long lengths, must guide the architect. Bartholomew, in his work on "Practical Specifications," now rather out of date, suggests several constructive expedients, and for stucco and cement entablature they are necessary. More modern plans are to use concrete with steel bars imbedded in the frieze part behind the ashlar; to insert wrought-iron flanged beams between the outer and inner faces of the entablature, or to use concealed flat brick arches with iron ties behind the ashlar if there is any weight. But a solid stone architrave, or architrave and frieze in two courses,

breaking joint, with joggled joints, is to be preferred for substantial buildings.

Our sketches give examples of columns—The first, Fig. 1, shows a colonnade, the columns and entablature isolated, with the mode of constructing the latter. Fig. 2 shows a solidly-built entablature with solid stone architrave; but the frieze is ashlarred, leaving a cavity filled with brickwork or concrete, *a*. Fig. 3 shows the architrave in two stones, the upper mouldings not being worked out of one stone, *b*; but there seems to be little advantage in this plan. The figures 4 and 5 show the springer and apex stones of a pediment. The bed moulding is worked in a separate stone for large cornices.

In Fig. 6 we show engaged columns taken from an actual building (St. Mary-le-Strand). These three-quarter columns, which are about 1ft. 8in. in diameter, adorn the church on both sides, and form the lower of the two orders used; the upper range of columns is of the Corinthian Order. These columns on the lower story stand on a high plain podium or basement. The intercolumnar spaces are rusticated with plain channels between the row of niches and pilasters, which channelled joints stop against plain vertical faces of projecting stonework, from which the columns project. The beds of each rusticated course occur at the top of each channel joint, and are continued through the plain ashlar backing, though we have not shown them in sketch. The columns are jointed as shown, the base stone level with top of first rustication, then a long stone, then a bonder in the centre equal to the height of two rustics, and then another long stone to the apophyge of neck of capital. The effect is good. In other cases, as at the Mansion House, the pilasters are composed of four long blocks, with three

intermediate stones of a course or two high, which are bonders. The thickness of bed of the bonding stones should be specified.

A semicircular niche is often required in Classical work. Fig. 7 shows one used between the side pilasters of St. Mary's Church. The head of niche is worked in two stones by a centre vertical joint, and we may imagine four such stones cut out of a single block. On the other side, *b*, the manner of jointing the back of niche is shown, the stones alternately breaking joint and bonding into the wall. Only two courses are used below head of niche.

30. *Columns.*—The columns of colonnade (or portico) to be worked out of selected Portland (or other) stone, free from vents, unsightly veins, sand-holes, and other defects, according to drawings, with bases and capitals as shown in detail. Each shaft to be diminished according to rule or drawing to a true entasis, and to be in three (or more) stones, the apophyges to be worked on base and capital. The beds of columns to be brought to a perfectly flat and level surface, and to have 4lb. lead seatings (or pitch-pine seatings) 1/2 in. thick, allowing 1 in. free all round from face (or to be bedded in stone-dust mortar). Or—

31. *Pilasters.*—They are to be monoliths, or are to be in not less than two blocks of stone. The caps and bases to be of solid stones jointed below the apophyge in one case, and above it in the other. The pilasters corresponding to the columns to be bonded not less than 9 in. (or 12 in.) into the wall every other course. Or—

The pilasters to be of three (or more) stones, and bonded every two or three courses into the wall to a distance of at least 9 in. Each stone to be wrought with true and level surfaces and beds.

32.—*Entablature of Portico or Colonnade.*—The architrave to be moulded as shown in detail, with three faces, and to be wrought out of solid stones, not less than 3ft. in length, the stones to be joggled together (see sketch *d*, p. 733); the joints to occur where shown in detail. Or—

(If the intercolumnar space is several feet,

rolled iron joists may be introduced, as shown in sketch; or a tied brick arch, or concrete beam with iron bars, may be used in the upper part; and mention should be made of any of these arrangements.)

33. *Frieze*.—The frieze to be solid, and of stones not less than 2ft. in length, and of the full height required to bed-moulding of cornice, and to break joint with those of architrave. (If to be enriched by carving, state) the stones to be 2in. more of extra thickness for the carver. Or—

The frieze to be of ashlar, 4in. or 6in. on bed, and the full height required, allowing 2in. or more on thickness for carving. The ashlar to be bonded every 3ft. or 6ft., and the cavity filled in with lime or breeze concrete or brick in cement. Or—

The frieze to be of ashlar, 4in. (or 6in.) on bed, the stones to be the full height of the member between architrave and bed-moulding of cornice, and to be carved to the architect's detail, for which purpose 2in. (or 3in.) extra thickness to be left, and to be jointed to the brickwork backing with cement (or bonded with a stone every 3ft. or 5ft. apart, to go right through).

34. *Cornice*.—The cornice of entablature to be of two (or three) layers, moulded according to detail, and the stones to be not less than 3ft. (or 5ft.) long, bedded the full thickness of frieze, with truly-worked beds and joints, and to be plugged with lead at the joints (or the stones to be united with slate dowels run in with cement), and the joints set in lime mortar. Or, if enriched, add—

*Enriched*.—The lower layer, or bed-moulding, to have modillions (or dentils), plain or enriched, which are to be carved after models approved by the architect. The soffit or corona to be sunk panelled.

35. *Balustrade*.—The balustrade (if any) is to be as shown in detail, with plinth, turned (or square) balusters, capping, pedestals, &c., each part solid. The plinth and capping to be in long stones, not less than 3ft. (or 5ft.) long. Each baluster to be dowelled with slate dowels in cement to the plinth and capping, and these are to be plugged with lead, or cramped with metal cramps. Or—

The balusters to be each wrought out of one stone, allowing, at least, an inch of joggle at ends into the plinth and capping. The vertical joints to be plugged with lead, and the capping to be cramped with cast-iron or bronze metal cramps. The half-balusters to be worked out of the same block as the pedestal.

36. *Pediment*.—The pediment to be constructed in strict conformity with the drawings and details; the horizontal cornice to consist only of the corona with the lower mouldings, the stones of both layers to be securely tailed into the masonry for not less than 9in. (or 12in.), and the stones of upper layer to have a length of at least 5ft. The raking cornices to be the same as the main horizontal cornice, and to be jointed as shown. At the springing of pediment the horizontal and raking members to be worked out of one solid block (see sketch), and to be securely bedded into the masonry of wall at least 12in. (or 18in.). The raking cornices are to be in separate stones, bedded in horizontal steps on the masonry behind to a distance of 12in. (or 18in.); or are to be cut in the form of steps. Or—

The raking cornices to be cut with horizontal beds every third stone, the others cut raking. The stones are to be plugged with lead (or dowelled), and the upper layer or moulding to be in stones of not less length than 4ft. or 5ft., breaking joint plugged with lead (or cramped with bronze cramps in cement), and to have a bed the whole thickness of wall, or state how much. The tympanum of pediment to be executed in courses of stone 6in. or 9in., on bed to match the ashlar below.

37. *Staircase Basement*.—The basement staircase to be constructed of 12in. by 6in. solid York stone steps, tooled (or rubbed) on all sides, projecting 3ft. (see sketch, section, Fig. 7, p. 697), pinned 6in. into the wall in cement as the work proceeds, rebated joint (or bedded in cement), two holes to be cut in each step for balusters. The curtail step to be 14in. by 7in., solid with scroll end. The winders, if any, or half-space landings to be 6in. thick, cut and pinned 6in. into wall with cement. The landings to be 3in. (or 4in.) thick, joggled (or grooved and tongued) together in cement. The thresholds of doors on landings to be of hard York 3in. thick, rubbed and back-jointed.

The steps, if solid, may be rebated together as shown, or simply spayed at the angles of contact. For ordinary steps, simple bedding in cement may be specified. Sometimes the holes or mortices in the brick walls are left for the stone steps to be put in after the brick wall is built. These holes or chases should be filled up temporarily with bricks bedded in sand, and the wall carried up some

courses above as well as below the stair-line with cement mortar. The outer or free ends of the steps are supported by timber till the cement is set. Landings of wide span are carried by an iron joist under the external edge. Concrete landings with iron imbedded are often used as substitutes, but of these we shall speak in another trade.

38. *Principal Stone Stairs*.—The main staircase from the ground floor to the first (or second) floor to be in a single (or double) flight of hard Portland stone steps, rebated at joints with moulded nosings along the front, outer end (and back of each step). The soffit of each step to be moulded, as shown in detail, each step to be tailed or pinned into the walls 9in. The landings to be 6in. thick, with similar moulded nosings, panelled on the soffit, and to be in one or more slabs tailed 6in. (or 9in.) into walls, and joggle-jointed (or rebated) with lead. Mortise the necessary number of holes for balusters. The bottom step to be cut out of a solid square section with a bold curtail. The whole to be rubbed smooth on all faces and soffits. Or—

The principal stairs to be of Portland stone steps and landings, as shown, tailed into walls 9in., with moulded nosings, and returned nosings at ends and back. The soffits to be moulded to the shape of the ends of the step (or according to detail). The solid steps to be jointed or rebated to 6in. landings with moulded nosings, the latter to have joggled joints run with lead, and to be tailed into wall 4in. or 6in.

#### FOUNDATIONS AS APPLIED TO LONDON BUILDINGS AND RIVERSIDE FOUNDATIONS.\*

(Concluded from page 774.)

THE value of the Greathead system of working enables a running stratum to be broken into without danger. Where buildings and wharfs are situated on the side of a river unsecured, and where the materials of its bed are not sufficiently firm to allow a shelf being maintained between the buildings and the low-water line, the shore may run down and carry the foundation of the buildings along with it. An instance of sand thus running occurred in 1837, during the progress of the Thames Tunnel, notwithstanding the close protection afforded in the shield used by the late Sir Isambard Brunel, the sand running in to such an extent that, at a distance of 50ft. east of the shield, the bed of the river sunk 13ft., bringing the river within less than 3ft. of the level of the excavation, while immediately above very little depression took place. A similar instance of running gravel is recorded when the shield approached the wharf on the Middlesex side, producing a conical depression 30ft. in diameter and 13ft. deep on the shore, followed by a subsidence of the wharf front. In the construction of the Blackwall Tunnel the use of the Greathead shield enabled the work to be successfully accomplished. In the construction of the Metropolitan District Railway between Westminster Abbey and Westminster Hospital the soil was sand and gravel, heavily charged with water, Westminster Abbey itself being on the sand. The nearest point of the works to the main walls of the hospital was 23ft., and to Westminster Abbey 70ft. 8in. The tunnel was made without the slightest settlement of adjacent buildings, notwithstanding the fact that, in wet sand and gravel, pumping was carefully resorted to, in order practically to dry the ground sufficiently for work. By the aid of iron tubing, and the use of compressed air with the Greathead shield, as adopted in the City and South London Railway work, we need experience no anxiety. You can work as safely in gravel charged with water as you can in London clay. The ordinary timbering of a tunnel is a yielding material, so that, unless special precautions are observed, there is a risk for the framework to yield which is employed to temporarily hold up the excavation before the brickwork is put in; but with an iron lining and cement grouting outside, there is no need of alarm. The

#### DANGER CONNECTED WITH PUMPING

is obviated when it is carefully done. If it is carelessly done, you may draw some of the finer particles of sand and water, and so undermine the foundations of an adjacent building to a greater

\* By ARTHUR T. WALMSLEY, M.Inst.C.E. A paper read before the London Architectural Association on Friday, May 20, 1898.

or less extent. Where any accidents occurred on the construction of the City and Southwark Railway it was near the brick stations, where wood centres were introduced; but by adopting cast-iron lined shafts to the stations with cement grouting outside, any danger to surrounding property is avoided. On the Metropolitan Railway ordinary stock bricks in blue lime were used. In the Metropolitan Railway settlements occurred, as it was constructed mainly without an invert. The ultimate improvement was to put an invert, which, of course, gave greater support from the pressure of the sides. The system of construction was in some cases tunnel—near Kensington, for instance—but generally cut and cover. With the use of the Greathead shield upon the Central London Railway, where not in the clay, compressed air is introduced, and the work is entirely in tunnel. The iron plates are properly jointed throughout.

#### BRIDGE FOUNDATIONS.

In the King's-road bridge over the Regent's Canal, Camden Town—designed by Messrs. Thomas and Taylor—the foundations were sunk 22ft. below the roadway level, or 1ft. 6in. below the water level in the canal, and 5ft. 6in. below the bed of the canal. The soil from the top of roadway to a depth of 18ft. was found to be of a clayey character, below which was found a seam of clay-stones 1ft. deep, and then clay suitable for a foundation. A trench 50ft. long was made, in which a concrete bed 8ft. 6in. square in section was built, with counterforts added at every 12ft. It was found that this ground could be timbered by experienced men without driving piles, and without pumping beyond the removal of a small amount of soakage while the men are not at work. Old Westminster Bridge, which was built between the years 1738 and 1750, consisted of thirteen principal and two smaller arches nearest the abutments, 25ft. span, all semicircular, springing from the piers at about 2ft. above the level of low water. The central arch was 76ft. span, but the principal lateral arches decreased in width by intervals of 4ft. each, and their intervening piers were supported by caissons consisting of rafts of timbers floated into position and then sunk in place, a level area having been previously dredged to receive them. Each raft was about 80ft. by 30ft. by 10ft. deep, made watertight all round, within which a portion of the pier was built, and the raft was then floated to the site of the proposed pier, the water admitted by sluices in the sides, and the foundation guided to its proper bed by ropes from a light barge previously moored off the shore. None of the foundations, which all rested on a substratum of sand and gravel, were at a greater depth than 14ft. below the bed of the river, and parts were not more than 5ft. or 6ft. The wooden platforms carrying the base of each pier thus ran the risk of settling upon an irregular foundation, and gradually getting undermined as the bed of the river lowers. Originally the piers were intended for a light wooden structure; but when it was determined that the bridge should be built of Portland stone, a stone casing was built around them. The bed of the river on which the caissons rested became undermined, particularly when, in later years, the tidal current, since the removal of the numerous piers of old London Bridge, ran off with greater rapidity than when old Westminster Bridge was erected, and produced a general, though not uniform, lowering of the level of the river bed. A similar plan was, however, followed in the case of old Blackfriars Bridge, built 1760 to 1770, the platforms here employed being 88ft. by 37ft., and two balks and a half thick; but in this structure bearing piles were introduced to obviate the liability to settlement. This bridge consisted of nine arches, elliptical in shape, constructed in Portland stone. The centre arch was 100ft. span, and the side spans decreased gradually to 98ft., 93ft., 83ft., and 70ft. Waterloo Bridge, built in 1811 to 1817, contains nine equal semi-elliptical arches of 120ft. span, and was the first bridge on the river in which coffer-dams were employed. These consisted of double piling, with puddle between, and did their work successfully during construction. Like old Westminster and Blackfriars Bridges, however, the foundations of Waterloo Bridge were left upon sand and gravel, and not carried down to the clay. Each pier was, however, built upon piles, there being one pile to every square yard of bearing surface. The heads of these piles were sawn off, and timber sills or bearing piles and waling

pieces fastened on both transversely and longitudinally, upon which a flooring of 6in. planks was fixed, and then the first course of masonry laid thereon. The system of laying the foundations dry in coffer-dams was followed in Southwark Bridge, and the same plan adopted at New London Bridge, the former built 1814-1819, and the latter 1823-1831. In Old London Bridge the piers were built on platforms supported on elm piles, driven into the bed of the river, and cut off at low-water level. In New London Bridge the foundation consists of timber piles 12in. to 14in. square, shod with wrought-iron shoes, weighing 35lb. each, and hoops 30lb. each, driven at intervals of 3ft. 6in. to 4ft. centre to centre, so that 16sq.ft. of masonry are taken by each pile. The bearing-piles are here driven into the London clay about 18ft. below the platforms. The importance of establishing a foundation to resist undermining action cannot be over-rated. Uniform width in a river produces uniform scour, which, while it creates a better channel for the discharge of flood-water, also attacks any impediments it encounters. Since the construction of the Thames Embankment, the bed of the river parallel to the Embankment has varied considerably. In New Westminster Bridge, completed in 1862, the foundation of each pier is entirely piled over with 145 elm piles, driven centre to centre, 3ft. 3in., and 2ft. 6in., passing through the gravel into the London clay, and cut-off below low-water. To avoid the expense of permanent coffer-dams, these piles were surrounded with iron piles connected by cast-iron plates driven between them, known as "plate-piles," so as to form a complete casing, the interstices between all the piles being filled in with concrete. They go about 10ft. into the blue clay, and extend about a foot above the gravel bed. Upon these is placed a series of slabs of granite edgeways, the plate-piles being secured by two sets of ranges of iron ties, passing through the pier, and fixed by divers, the granite slabs secured both by the masonry of the pier and by the main piles to which the plate piles are connected. A complete caisson is thus formed, which has caused the necessity of the interior piles to be much questioned. In new Blackfriars Bridge, built 1864-69, wrought-iron caissons were employed for the foundation. Each pier stands upon four independent rectangular caissons, 36ft. by 18ft., carrying the centre of the pier, and two triangular caissons projecting beyond, to carry the cutwaters. These caissons were built upon a stage, and lowered, by the aid of guide piles, into their assigned position, with their cutting edge resting on the bed of the river. The ground inclosed in each caisson was then excavated by divers, and the caissons sunk by being weighted with iron kentledge until the clay was reached, when leakage ceased, and the caisson by protracted loading took its final bearings at an approved depth of excavation. A material like the London clay is for all practical purposes incompressible, especially when prevented from spreading laterally, and so deep down as to be unaffected by heat or damp. The caissons were then filled with concrete in cement, upon which was placed 8ft. of brickwork in cement, the top of which was at a level of 4ft. below low-water mark. A space of one yard was left between the caisson sections, which was subsequently filled with concrete in cement up to the same level, so as to provide an uninterrupted area over the base upon which each pier now stands, and the movable portion of the caissons above 4ft. below low-water level were removed as the work proceeded. Cylinder foundations were first used by the late Sir W. Cubitt, at Rochester, and their employment has since been efficiently tested to show their adaptability for foundations. They were adopted for the original railway bridge at Blackfriars, 18ft. diameter, below the stone piers. Cylinder foundations, 18ft. diameter below, and 12ft. diameter above, the bottom of the river are used for the piers of the Cannon-street railway bridge. At Charing Cross the cylinders are 14ft. diameter below and 10ft. diameter above the ground. The foundation cylinders of the Albert Bridge at Chelsea are 21ft. diameter, and their mode of fixture is described by the author in the discussion which took place on Mr. Crutwell's paper at the Institution of Civil Engineers, in which the foundations of the new railway bridge across the Thames at Blackfriars were described, and for which rectangular caissons, sunk 16½ft. to 23½ft. below the river bed, were adopted (see *Min.*, Inst. C.E., Vol. CI.) The Victoria railway bridge over the river at

Battersea was originally constructed with piers on the up-river side standing on a bed of cement concrete inclosed by permanent sheet piles driven to a depth of 8ft. below the lowest foundation level; but, when widened, the increased width of foundation was obtained by sinking permanent cast-iron cylinders to a depth of 45ft. below Trinity high water on the down-river side, four to each pier, 21ft. internal diameter, and 24ft. long, cast in segments 8ft. in length, with flanges for bolting together. These cylinders were filled with cement concrete for a depth of 12ft., upon which was laid brickwork in cement up to low-water level, above which level temporary wrought-iron cylinders were employed. The foundation cylinders were united at the top by a framework of cast iron, but the masonry between the cylinders is principally carried by brick arches in cement turned between the cylinders in the hearting of the piers, which from this level to the springing line consist of solid brickwork in cement faced with masonry, so as to present the appearance above low water of a continuous pier.

## RIVERSIDE FOUNDATIONS.

In the foundations for the destructor cells and chimney-shaft designed for the borough of Great Yarmouth, concrete blocks were employed, built in brickwork cylinders as shown, and the maximum pressure per square foot on the subsoil was calculated to be 4 tons 6½cwt. The ground is of a very marshy character overlying sand and coarse gravel, into which the foundation is sunk. The cylinders are constructed of 9in. brickwork, built in Portland cement, the lower 4ft. being encased in a wooden drum, with cutting edge sunk into the gravel and sand at least 2ft. The cylinders are sunk by the aid of a grab, the bottom being levelled, and the concrete blocks laid by a diver. In this way the risk involved by pumping, which might disturb the foundations of cylinders already in their places, would be avoided. The blocks are grouted through a 3in. pipe with liquid cement, the joints and lewis holes having been previously filled with coarse, clean shingle. After about four days to permit the grout setting, and thus forming a watertight bottom, the cylinders are pumped out and filled with concrete composed of six parts shingle, one part sand, and one part Portland cement. The remainder of the buildings, which are low, and light in weight, have concrete foundations tied with iron joists and spread to such a width that the subsoil shall not receive a greater weight than half a ton per foot superficial, which, it has been ascertained by experiment, can be carried on this soil after the upper layer of turf and roots has been removed. The Dover Electricity Supply Company erected works adjacent to the River Dour, from which the town is named. These works included a chimney, designed by Mr. F. G. Knight, of Westminster, about 130ft. high, with a concrete base 24ft. 3in. square, by 5ft. deep. The River Tyne at Newcastle affords instructive examples of riverside foundations. The old quay walls, with a depth alongside at low water, varying in the year 1840 from 2½ft. to 5½ft., had a piled foundation, and when in 1866 deeper quays were deemed essential, 12ft. of water at low tide was considered ample, which was subsequently increased to 22ft. Piled foundations were adhered to, until upon the advice of the late Mr. T. E. Harrison, Engineer to the North-Eastern Railway Company, cast-iron cylinders sunk under atmospheric pressure for the substructure of the quay were adopted for new work, as cheaper than piled work. Two rows of cylinders were employed, each 5ft. diameter, placed 25ft. centre to centre longitudinally, the front and back cylinders being surmounted by cast-iron beams, from which masonry and brick arches were turned. Longitudinal metal sheet piling, up to the level of low water, was driven in the form of a segment between the front cylinders, but proved too weak for the increased depth of water, after the bed of the river had been dredged out. The intervening sheet piling was done away with, and a more continuous front row of cylinders substituted, 13ft. 9in. centre to centre with elliptical cylinders intervening. These likewise proving too weak, a close row of 6ft. front circular cylinders was tried, the back cylinders remaining as before, but tied to every alternate front cylinder by a wrought-iron band passing round both. The same method was adopted under a large grain warehouse built on the quay. Finally, in the rebuilding of part of the 1840 wall, monoliths of concrete were, upon the

advice of the late Mr. P. J. Messent, engineer to the Tyne Commission, sunk for the foundation of a wall constructed to give a depth of about 20ft. at low water spring tides, and this plan has since been applied to the reconstruction of all the old quays requiring renewal. The blocks are 30ft. long, 20ft. wide, and 37ft. deep, with a well 20ft. by 10ft., and walls 5ft. thick, forming concrete caissons, sunk to an average depth of about 32ft. 6in. below low water, and are set about 2ft. apart, the interior and also the space between them being filled with concrete. On these blocks the masonry and concrete superstructure was built. Concrete cylinders have, upon the advice of the late Sir John Coode, been employed by his successors, Messrs. Coode, Son, and Matthews, for the foundation of the abutment to the new east pier to the Outer Harbour Extension at Dover. These cylinders were cast upon a lower seating ring 12in. deep, to form a cutting edge, the cylinders being 7ft. external diameter, 15in. thick. They were cast in wood moulds with 5 to 1 Portland cement concrete, and were allowed to set at least ten days before lifting, and to season one month prior to removal from the yard to their destination. The top and bottom edges of all intermediate rings are toothed 6in. deep, and tapered 1in., so as to key into each other when sunk *in situ*. The cast-iron cutting edge shoe is bolted into the bottom ring by 1in. bolts, let in flush at the top. The interior concrete is placed in position by means of skips, so arranged as to deposit the contents as close as possible to the concrete previously deposited. Between this abutment and the old north pier of the existing harbour entrance a sea-wall exists, built by the late Mr. James Walker as engineer, in which a row of cast-iron sheet piles were driven at the toe of the outer slope between the wall and its apron. Messrs. F. and H. F. Higgs built, in Upper Thames-street, a warehouse with a river-wall going down about 10ft. below the river-bed, which was easily effected by means of the usual cofferdam of 12in. piles planked each side with clay puddle between, notwithstanding the fact that in sinking the other foundations a brick sewer running parallel to the river, about 40ft. from the bank and at about 15ft. down, constructed by the District Railway Company to drain their tunnel, was encountered. At Stratford the premises built by this firm were against one of the many tidal cuts in that district; hence a river-wall had to be constructed. This Messrs. Higgs managed with light piles and single planking, with tarred and tongued joints bolted outside the piles—a construction sufficient to resist quiet water of no great depth. The Horse Shoe Wharf in Upper Thames-street, built by Messrs. Holland and Hannen, was erected in 1888 and 1889 for Messrs. Pilkington Bros., glass manufacturers, by Messrs. Francis Chambers and Son as architects. The frontage of this warehouse is about 32ft., the river wall going to a depth of 30ft. below the average high water level, the basement floor being about 6ft. below high water level. In excavating for the foundation, the strata passed through was made ground 12ft., wet mud, dirty gravel, old piles and previous foundations, shells and silt, lastly, clean ballast. In order to build the river wall, a coffer-dam was formed by driving in two rows of 12in. by 12in. pitch-pine sheet piling 6ft. apart. The piles were strapped together and the rows securely laced together with iron ties. The space between the sheeting being filled in with clay puddle, and the whole construction firmly shored from the ground at the back. A shield was provided in the dam at shore level as a precautionary measure for draining off, as the tide receded, any sudden rush of water that might have accumulated within the dam through extraordinary flood or other tides. In this instance the whole area of the basement, occupying between 15,000 and 16,000 square feet, was excavated at the same time. A deep sump-hole was formed, and a steam chain-pump kept constantly going to keep the excavation clear of water until the permanent river wall was constructed. It may be interesting to note that while getting out these excavations, the old Kentish rag foundations of Baynard's Castle, which occupied the site in the time of Queen Elizabeth, were discovered. The river wall of Brook's Wharf, Upper Thames-street, was built tide work by Messrs. Holland and Hannen. A sound foundation was obtained at a depth of 14ft. below the level of the shore, but no record has been kept of the class of soil passed through. The excavation, concrete, footings, &c., were carried

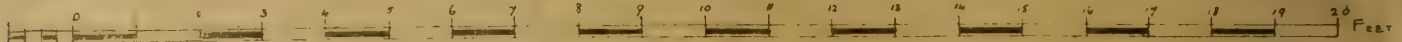

Scale of Feet.

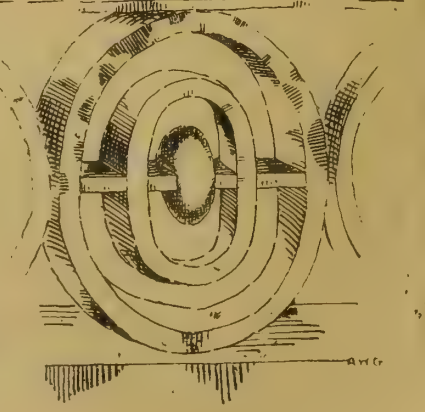
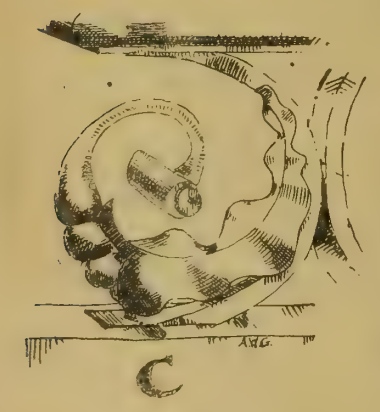
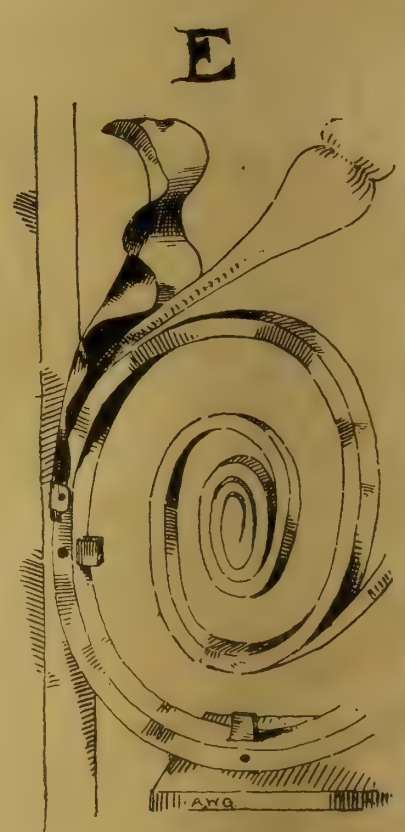
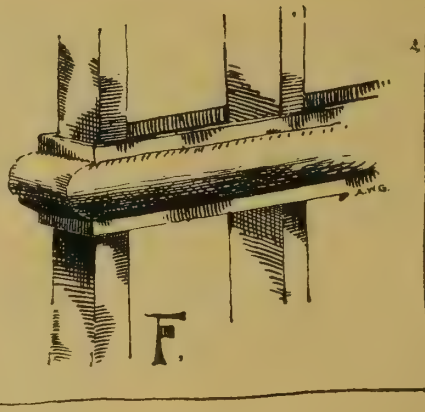
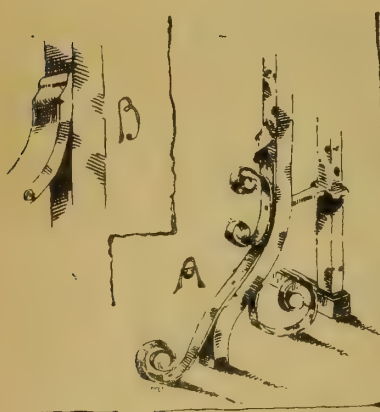

out in short lengths, as in underpinning, during the time the tide was out, and the work done was carefully covered up or cased in before the water reached it. The casing of brickwork, &c, was in no way watertight, but was sufficient to prevent the washing action of the tide. This is an economical method of constructing a river wall, but of necessity rather slow, and can only be adopted in particular cases. In 1880 the same firm constructed a quay wall to their own property in Nice Elms-lane. The length of wall was 100ft., and height 18ft.; this was also carried out by tide works as in the previous case, but is constructed entirely of Portland

cement concrete. This is a very inexpensive form, costing between £4 and £5 per foot run complete.

IRONWORK AT SOUTH KENSINGTON MUSEUM.—V.

By G. A. T. MIDDLETON.

VI.—ENGLISH: THE HAMPTON COURT SCREEN.

THE famous Hampton Court screen, designed by Jean Tijou, and supposed to have been wrought by Huntingdon Shaw, of Nottingham, about 1693 A.D., is, considering its actual

massiveness and power, distinctly disappointing when reduced to a small-scale fine drawing. Its grandeur lies in its exquisite workmanship and in its wealth of foliage ornament more than in the outline of its design, and the effect is enhanced by the details being in bold relief, and the enrichment being mostly duplicated, and applied to both sides of the screen alike.

The detail drawings show that the curves are of a rounded character, that the structural work is of bar and sometimes moulded iron, and that much use is made of the pin or rivet, the most peculiar connections being those shown at O and E.

GASWORKS MACHINERY.

At a meeting of the Society of Engineers, held at the Royal United Service Institution, Whitehall, on Monday evening, June 6, 1898, a paper was read by Mr. Edward A. Harman, entitled, "Gasworks Machinery." The author first pointed out the close relationship of gasworks machinery with other branches of engineering. Attention was then directed to the deteriorating influences to which gasworks machinery was subjected, on account of coal and coke dust, and the presence of miscellaneous waste gases. The author pointed out the severe conditions under which some portions of the machinery had to be operated, such as the handling of red hot coke at a distance of 2ft. or 3ft. from the face of the machine; he also referred to the influence of contraction and expansion on the various parts of the machinery, due to working under variable temperatures. Attention was then drawn to the special objects of gasworks machinery. Continuous carbonisation was referred to as having been experimented with, but had not resulted in being adopted. The erroneous impressions of the arduous nature of retort house work as now existing were referred to, and it was stated that if a comparison could be made with labour in other works a different idea would prevail. Attention was then called to the

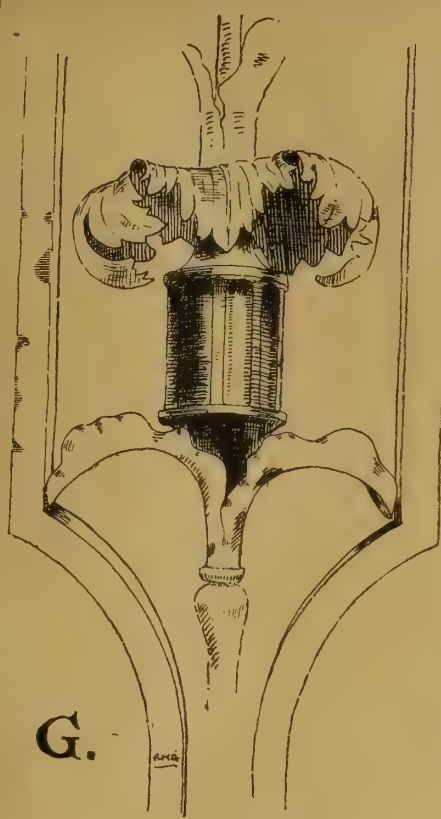

G.

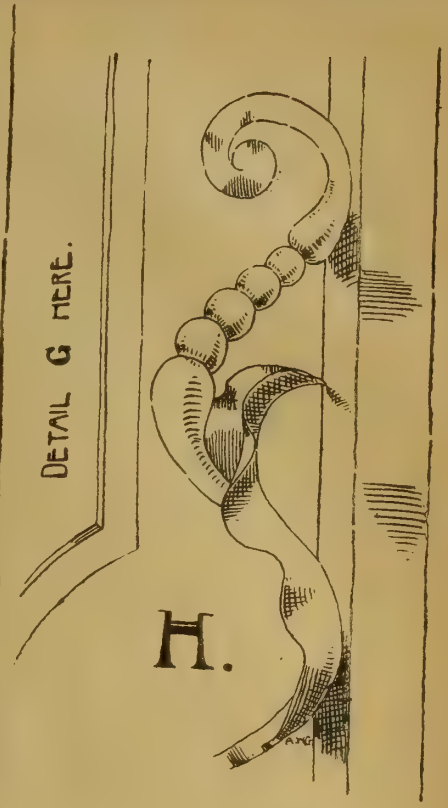

DETAIL G HERE.

H.



CENTRE OF THIRD PANEL.

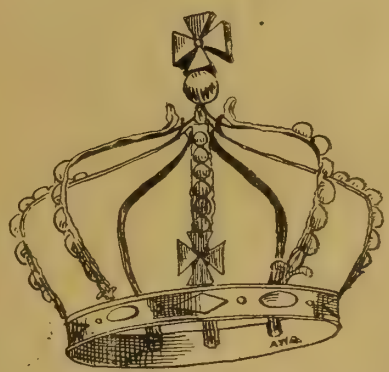

I.



J.



K.

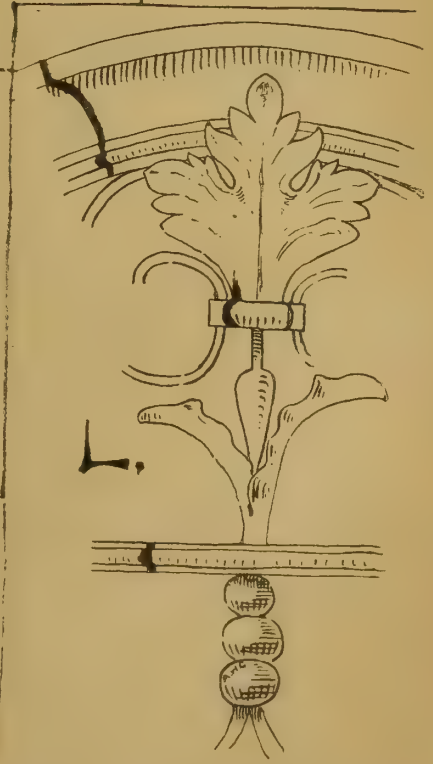

L.

numerous novelties existing in gasworks. The magnitude of the operations required to be performed by gasworks machinery was shown by the carbonisation of 12½ millions of tons of coal in the United Kingdom annually. The exhausting plant used was explained at length; the author combating the common erroneous idea that atmospheric air was drawn into the gas, and explaining the functions of the exhausters for drawing the gas from the hydraulic main, leaving the dip pipes always sealed; and for forcing the gas through the purifying apparatus; and also for raising the gasholders. The difficult duty required from pumps was referred to—viz., that of having to raise substances ranging from light spirits to almost thick solid matter, at various temperatures from zero to nearly boiling point. The coal and coke stacking operations were then reviewed, attention being called to Mr. Marshall's extensive installation at one of the Copenhagen gasworks, for the Danish Gas Company, which is capable of unloading and stacking about three quarters of a millions tons of coal in six months. The Temperley transporters were also described. Coke conveyors were considered, special reference being made to that designed by Mr. Henry Hack, M.Inst.C.E., at one of the Birmingham gasworks, and to the design of M. de Brouwer, of Bruges. Coke breakers with circular steel sheets were stated to

be most desirable for cutting the coke, instead of crushing it. Gas engines and tramcar motors were also considered. Regenerative furnaces were stated to be considerably reducing the consumption of fuel on gasworks, while giving higher heats and vastly better working results. Lifting and travelling apparatus for purifier covers was stated to be generally worked by

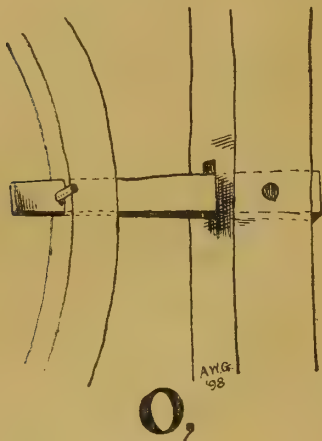
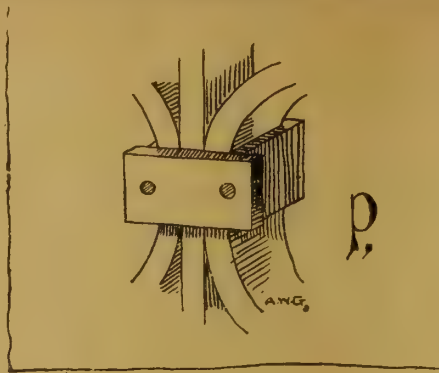
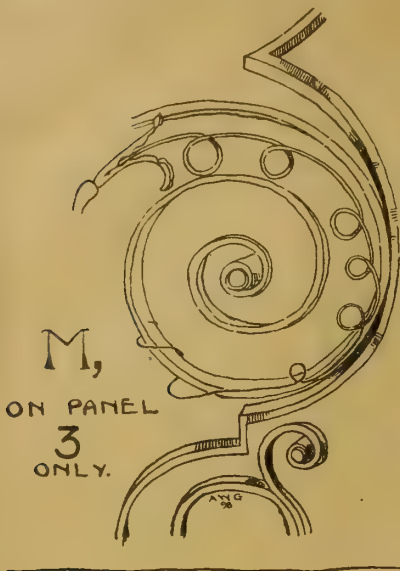

THE HAMPTON COURT SCREEN.

“BUILDING NEWS” DESIGNING CLUB.

DINING-ROOM OAK FURNITURE AND CHIMNEYPIECE.

BUNGALOW furniture, for which uses the accompanying pieces are intended, should be distinctly plain and simple in character. Its construction should be straightforward, and, if anything, ought to be more like joiners' work than favour necessarily the productions of a cabinet-maker. This remark applies less, of course, to the chairs, for, indeed, chairs in any case are the speciality of the chair-maker. We suggested that the furniture designs to be submitted in this competition should be suitable for the living-room of the Bungalow, which formed the subject of the previous “B. N.” D. C. contest. The three best designs for the Bungalow itself were illustrated in our pages for May 20th, and it will now be seen that the author of the plan placed first on that occasion is the designer of the furniture which we have chosen as the best proposal to-day. This circumstance has not in any way influenced our choice, however; in fact, it was not till after we had determined on the order of merit of these furniture designs that we became aware, by reference, that “Centaur's” plan for the Bungalow had been awarded the post of honour. “Nothing succeeds like success”; but we are far from saying that these furniture designs by “Centaur” are everything that could be desired, or that their success is unqualified. The second degree of merit is accorded to “Pantile” and the third position is taken by “Hotspur.” The following are the instructions issued for the use of the competitors:—A suite of oak furniture and chimneypiece, suitable for the living-room of the Gentleman's Bungalow which formed the subject for the sixth and last competition of our Designing Club. The room is 24ft. long by about 18ft. wide. The chimneypiece is to have a fire 18in. wide. The whole composition is to be 4ft. 6in. wide, and the total height is to be not less than 7ft. 6in. including the overmantel. A good shelf is to be provided, and tiles are to be introduced round the slow-combustion firegrate. The table is to be suitable for a dining-room. One armchair, with leather seat, and a sideboard. This latter is to be 6ft. long, and have cupboards and drawers below, with buffet shelves above. The entire height is not to exceed 5ft. Style left to the competitors. Scale for general drawings, inch scale, and details quarter full size. Plans sufficient to show the design, and armchair may be shown only by a view. A view of the buffet is desirable.

Very few members responded to the invitation thus afforded for their display of inventiveness, and while many architects complain, not infrequently, that clients do not often give them an opportunity of designing furniture for the buildings erected from their plans, it is quite clear that only a very few architects devote any attention to the subject, although furniture must always of necessity play a most important part in the success or failure of a building, judged as a whole as a work of art. Pupils in the majority of offices seldom or ever see any furniture designs produced by their principals, and experience has shown what dreadful stuff some men, calling themselves architects, have turned out in the way of board-room and other furniture, sometimes called by the passing phrase of “fitments.” This being the case, we think those members of our club who have risen to the occasion by sending in designs for this suite of oak furniture deserve commendation, because in all probability they have individually gone beyond the routine limits of the particular offices in which they may be working, and have studied furniture apart for its own sake; and possibly they have done so with the idea of qualifying for an extended sphere of usefulness. If so, they are wise. There can be no doubt that there is plenty of scope remaining for the gifted designer in this branch of decorative design, and while originality of idea is of prime importance, good taste and a keen sense of fitness is even of more value. Architects at the best are so accustomed to planning structural woodwork, that they are liable, more or less always, to make the scantlings of the furniture they design too big and massive, an error in some sense on the right side; but the furniture thus designed is generally ineffective and faulty in the essential element of proportionate scale. “Centaur's” sideboard is an example in point, though, as we have already indicated, the rough-

hydraulic power. The recovery of the large quantity of waste upon gasworks was mentioned as being gradually coped with, such as the quantity of gas lost during the operations of charging the retorts, the coke dust, spent lime, waste hot water from various processes, and also the unrecovered cyanides in the coal gas. Stoking machinery was dealt with at length, Mr. West's compressed air system being first described, and afterwards the Arrol-Foulis system. Coal breakers, elevators, and conveyors were also described. The depreciation of gasworks machinery was regarded by the author as not being greater than with other machinery, as the wear and tear of the renewable portions had to be made good as required. The author, in conclusion, stated that he considered that rule of thumb methods were rapidly giving place to systematic methods and design. The paper was very fully illustrated.

THE COLLAPSE OF A BASEMENT VAULT AT MARYLEBONE.

DR. DANFORD THOMAS held an inquest on Saturday respecting the death of George Uncine, twenty-two, bricklayer, of Paddington-street, Marylebone. Robert Leggatt, foreman to Messrs. H. Burman and Sons, said his employers were rebuilding the Devonshire Arms tavern, Devonshire-street, Portland-place, and on Thursday Uncine and another man named Daniel Mackie were working in the basement of the premises. The vaults of the tavern extended under a mews beside the house. Uncine and Mackie were putting in a pier through the vaults, in the wall of one of which a crack was discovered. As soon as it was discovered, someone shouted, “Look out; here it comes.” The arch of the vault and wall then fell in, burying Uncine beneath a superincumbent mass of wreckage.

The Coroner: Do you think since these building operations have been in progress anything has occurred to lessen the strength of the arch? Witness replied that the foundations of sandy soil might have been affected by the heavy rain, and hence the collapse. The pier was being put in 10ft. distant from where the crack showed. Shortly before this some heavy loads had passed over the crown of the arch. The man was extricated as speedily as possible, but life was then quite extinct. Replying to Mr. Crabtree, inspector of factories, the witness said the bed of the old brickwork rested on nothing but sand. None of the shoring gave way. Daniel Mackie, bricklayer, who was working with Uncine, said there was no shoring in the vault, as there should have been. Witness added that he made no complaint to the foreman. The bricks were soft and rotten. They were about 100 years old. Mr. A. Ashbridge, district surveyor, said he approved the plans for reconstructing the Devonshire Arms, and considered the works were turned out satisfactorily. His belief was that when the hole was dug for underpinning, the sandy foundation gave way, probably owing to recent rain, and so weakened the side wall of the arch. Mackie was wrong as to the age and condition of the old brickwork. But for the rain witness did not think the accident would have occurred. Mr. Crabtree, on behalf of the Home Office, stated his conviction that the brickwork was good; but that, owing to the heavy rains, the sand foundation had eased down and caused the accident. The jury returned a verdict of “Death from an accidental cause.”

The tender of Mr. W. A. Linton, at £7,350, has been accepted for building the new church of St. John the Baptist, on Risca-road, Newport, without the tower. The foundation-stone will be laid on Monday, the 20th inst.

and-ready freedom of Bungalow life undoubtedly does suggest an avoidance of delicate detail and multiplicity of parts. The inclosed ends above the table-top prevent the ready use of a buffet cloth on the sideboard. The plans and sections are shown in a workmanlike manner, so that either the chimney-piece or sideboard could be readily made by any skillful joiner. The Gesso panels in the overmantel would be another matter, and unless a really capable artist designed them, the effect would be quite spoiled. Executed with taste, no doubt they would be spirited and very pretty. Three good figures in illustration of some fancy or poetic idea would much enhance the interest of the design, of course. "Pantile's" designs are distinguished by a tasteful reserve, and they harmonise in their unambitious simplicity. The sideboard is not so quaint, however, as to avoid the commonplace. The proportions account for this, and the long shapes of the glazed cupboard doors in the upper part seem very ungainly. An absence of fuss is welcomed by refined taste, but an interest is always imparted by some display of a quiet fancy. The panels to the cupboards in the body of the piece are so very meagre, and the same remark applies to the upper portion of the chimney-piece. A little ingenuity of structural framing or mitring of the mouldings would have sufficed to impart a trifle more interest even for a Bungalow. The heart-shaped device is introduced rather nicely in the mode we are suggesting. "Hotspur" is more ordinary, and does not draw so crisply. His chimney-piece is not lacking in refinement, but the overmantel piles itself up in tiers without concentration of interest. An unqualified set of pigeon-holes in a way has an air of fitness, and dresser-like shelves for holding a display of fine blue ware can be made to look admirable, as a quiet setting for real works of art. We make no objection to repeats as such; but when, as in this case, a composition is made of the design by a series of shafts, cornices, and a big central opening, the side recesses become piers to the middle portion, and emphasis of scale is rendered desirable in their parts: otherwise, the whole thing resembles the piling up of cigar-boxes in idea. "Hotspur" brings his table-legs right out to the corners of his table: the same fault is noted in the two best designs. It is always an advantage to get the legs away from the angle of a dining-room table, out of the way of the servants' feet when serving, and, of course, the legs should be out of the way of those sitting at the table. "Byd" contests the third place somewhat sharply with "Hotspur," for in some respects "Byd" is the better man of the two. However, we have taken as comprehensive a view as we can. "Byd" draws thinly and without much spirit. His care and endeavour to do well we have duly noted, though the perspective of his table-legs is not so careful as it might have been. The chimney-piece has a dual arched recess, divided by Jacobean columns between broad fluted pilaster stiles at the ends. The sideboard buffet is needlessly lumpy in its parts, and crude in its massiveness. "Dachs" is more ambitious with a frieze over his fireplace, suggestive of hunting. Above the curved shelf occurs a series of figure panels, indicative of other sports, we presume. The copper hood to the blower is not very pretty; but the general notion of the composition, with its curves on plan, shows a study of the parts which merits approval. The sideboard is not very nice, and its details are poor.

THE BUILDING TRADES DIRECTORY.

IN the new (eighth) edition of *Kelly's Directory of the Building Trades*, which is a portly volume of considerable thickness, and is now absolutely indispensable in the office of every architect and contractor, and all engaged in trades connected with building, some useful facts are summarised in the preface. It is assuring to be told that the present position of the building trades is very prosperous, and the editor quotes a report of the Central Association of Master Builders of London, in which the future prospects of the trade appear very satisfactory. The unfortunate engineering strike of last year has no doubt been felt; but the building trades on the whole have not suffered. Notwithstanding the great loss and privations sustained, the report states, "Petty strikes of plasterers have occurred in a number of firms, and the remonstrances of the council and committee

have been either met by evasions or the *non possumus*, and though no serious inconvenience has resulted, undoubtedly loss and annoyance have been inflicted." The report continues: "The conduct of all the trades appears to be determined by considerations more or less Socialistic and Communitic, and without regard to the reasonable and proper relationships which should exist between the employes and their employers, and the entire absence of any recognition of the obligations on the part of the former to give a fair day's work for wages received; but, on the other hand, to rather regard what they get from the employer as lawful plunder." These are rather severe strictures, and we hope some better explanation can be found. The editor speaks also of the important works undertaken in London by the L.C.C. and London School Board in the erection of workmen's dwellings, &c., the developments in sanitary and electric science as they affect building. The statistics quoted are of interest. It is stated that the amount of timber used in building imported into this country during 1896, including hewn, sawn, house-fittings and joiners' work, &c., was 8,464,282 loads, valued at nearly nineteen and a quarter millions. These totals show a large increase in every description since 1893 of timber imported, and about two millions in value. The above returns are exclusive of mahogany and hardwoods. The exports are also large. Cement is estimated in tons at 353,769, valued at £580,417; lead, rolled sheet, 22,537 tons, valued at £309,849; painters' colours valued at £1,658,180; and slates tale at 30,439,000, valued at £190,984. The total value of stone of all kinds raised in this country is between seven and eight millions, and of slate and slabs produced under the Mines Acts 581,760 tons. The importation of stone, marble, and slate into this country is given at a total of 673,206 tons.

The number of persons engaged in building in London alone is estimated at a total of 120,434, including the various trades. Architects alone number 2,024, surveyors 1,271, builders 8,866. Carpenters and joiners number 32,332, and painters and glaziers 32,666; the other trades show smaller numbers. Throughout England and Wales, the number of architects is computed at 7,842, surveyors 5,836, and builders 37,815, and these last find employment in the various trades for a total of 686,752. Other trades connected with building are enumerated, such as those engaged as stone, slate, and tile dealers, stone quarriers, cutters and dressers, lime-burners, cement manufacturers, paviors, labourers, &c.

ARCHITECTURAL METAL-WORK.

THE artistic metal-work of Mr. George Wragge, the Wardry Metal Works, Salford, Manchester, and Surrey-street, Strand, is well known to the readers of the *BUILDING NEWS*. Last week we drew attention to his very interesting stand of decorative metal-work at the Art Metal Exhibition at the Royal Aquarium, and we now call attention to his newly-published illustrated catalogue, which comprises several branches of metal-work of value to the architect. The casements and frames made by Mr. Wragge are of superior design and workmanship. The designs include a registered design (No. 19) in steel, iron, and bronze, guaranteed watertight, to open outwards, with full-size details of frame and casements, showing the mode of fixing to the stone jambs and mullions, the grooved frames and water-tight sill. The No. 20 section in steel, iron, and bronze is similar, but the casement frame has two grooves. The outer frame is sunk, so that a bar can be fitted, and the straight joint avoided. Other sections are illustrated suitable for different windows: many are made to open inwards or in and out, and to swing on pivots. We advise all architects to consult this catalogue before specifying. Forms of specification are given. Top-hung casements are also shown. These sections are perfectly watertight, and a special channel for condensation is shown on the inside of the sill of the inside opening casement with a bronze weather-bar on the outside. Many of the ordinary forms are illustrated, and these are made in two different qualities. These fittings can be made to suit wood casements. The sections for wrought-iron and steel sections are useful. Several forms of windows in wrought steel, with mitred joints, and cast iron; hospital and other metal windows, with secret

opening gearing, are illustrated in subsequent pages. The designs for wrought handles to metal and wood casements are very artistic and simple; also the back plates taken from old examples in hammered iron. Attention may be directed to several illustrations of very pleasing designs for park gates; door furniture in bronze, copper, brass, pewter, and aluminium; cabinet metal-work in the above metals, repoussé and beaten work, ecclesiastical metal-work and screens; dog grates, vanes and terminals, electric light and gas fittings in various metals, in hammered metal or cast. Full particulars and prices are given for many of the departments.

ART METAL EXHIBITION AWARDS.

THE following is a list of the awards in the Designs Competitions, at the Art Metal Exhibition:—

- No. 1.—A street lamp-post for electric light; scale 3in. to the foot. No award.
- No. 2.—A wrought-iron open panel, 2ft. 6in. by 1ft. 6in.; scale full size. Silver medal, V. Shaw, 105, Hungerford-road, London, N. ("St. Eloc"); bronze medal, G. Ramsdale Tucker, Hazlemere, Green-lane, Northwood, near Rickmansworth ("Tuclark"); certificate, Hugh Stirling, 12, Vauxhall-street, Dudley ("Reversible").
- No. 3.—A weathercock, 7ft high, on 6in. square lead-covered post; scale 3in. to the foot. No award.
- No. 4.—Repoussé coal scuttle in copper; scale full size. Bronze medal, Herbert C. Maw, Severn House, Coalbrookdale, Shropshire ("Utility").
- No. 5.—Pair of wrought-iron carriage gates and piers, opening to be 10ft. wide; scale 13in. to the foot, with necessary details full size. Silver medal, T. R. Spence, 28, Newman-street, London, W. ("Memsr"); bronze medal, Arthur Manock, Benfield House, Boscombe Park, Bournemouth ("Practical").
- No. 6.—Wrought-iron grille, 12in. high by 8in. wide, in solid oak door, with hinges, lock-plate, and knocker; door 4ft. wide and 8ft. high; scale 3in. to the foot. Details full size. Silver medal, A. Harold Smith, 4, Fairlop-road, Leytonstone, Essex ("Wessex"); bronze medal, Chas. R. Warren, 17, Pepper-street, Chester ("Hindoo").
- No. 7.—Wrought-iron ornamental open screen with door in centre, dividing a hall in residence, the hall 13ft. wide and 12ft. 6in. high; scale 1in. to the foot, with necessary details full size. Bronze medal, Albert Waldron, 21, Russell-road, Boves Park, London, N. ("Heron"); certificate, Herbert W. Doe, 30, Speenham-road, Stockwell, S.W. ("Nature in Art").
- No. 8.—Wrought-iron brass casket with enamel panels; its object is to contain the freedom of a City to be given to a General who has served Her Majesty successfully in India; scale full size. No award.
- No. 9.—Metal end of a coach-pole for a Mayor's State Carriage; the City is a seaport; scale full size. No award.
- No. 10.—A brass repoussé book-cover; the book is the "Pilgrim's Progress," its size large quarto, scale full size. Certificate, Chas. Wm. Crosby, Broome Hurst, Dorking, Surrey ("Apollony").
- No. 11.—A grille, to fill a semicircular arch 10ft. wide; the design is to be executed in wrought iron, and is to contain a central feature; it is suggested that electric light might be incorporated in this feature, but it is not compulsory; scale 3in. to the foot. Silver medal, R. Quilter Lane, 73, Hammer-smith-road, West Kensington ("Anchor"); bronze medal, Hugh Stirling, 12, Vauxhall-street, Dudley ("Ling"); certificate, Mary Gondir Simpson, 199, Camberwell-grove, Denmark Hill ("Bulger").
- No. 12.—A lectern in brass or iron, suitable for a parish church; scale 3in. to the foot. No award.
- No. 13.—Wrought-iron balustrade, 4ft. wide, projecting 3ft., and supported by cantilevers; scale 3in. to the foot. Silver medal, A. Harold Smith, 4, Fairlop-road, Leytonstone, Essex ("Wessex"); bronze medal, Herbert C. Maw, Severn House, Coalbrookdale, Shropshire ("Bull Rest").
- No. 14.—Ornamental guard to prevent flower-pots falling into the street from the window-sill; drawing need only show two-thirds in width of the design; scale full size. Bronze medal, A. Harold Smith, 4, Fairlop-road, Leytonstone, Essex ("Wessex").
- No. 15.—Cast-iron stove and mantelpiece with overmantel fire, 14in.; mantel-shelf, 4ft. 6in. long; total height not to exceed 7ft. 6in., including overmantel. Plan, front elevation, and end elevation; scale, 1in. to the foot. Details, full size of mouldings and enrichments sufficient to illustrate design. No award.
- No. 16.—A ewer and basin, soap dish and sponge basin; full size. No award.

AWARDS FOR CRAFTSMANSHIP.

A bronze medal and certificate: F. G. Francis, 33, St. Michael's-street, Folkestone; R. Western, 5, Bravington-place, Harrow-road, W.; A. W. Etwood, 9, Kennington Park-gardens; Annie Williams, 334, City-road, E.C.; Central School of Arts and Crafts, 316, Regent-street, W.  
A certificate: Thomas Taylor, 16, Sales-street, Pye Bank, Sheffield; Wm. Steer, 64, Longhedge-street, Battersea, S.W.

PROTECTION AGAINST FIRE IN THE CITY.

THE city engineer (Mr. D. I. Ross) has reported to the Corporation on the great fire in Cripplegate. In regard to improved facilities for dealing with outbreaks of fire, he points out that there are four brigade stations in the City—viz., Watling-street, Victoria Embankment, Whitecross-street, and Bishopsgate-street. In addition there are 15 sub-stations, at which men with hose-carts and other appliances for fire

extinction are always in attendance. The Corporation at their own expense laid down a complete system of fire-hydrants in the City. These hydrants, each of which has two outlets, are 829 in number, and are constantly charged with water at good pressure. It is the custom universally outside the City to indicate the position of the fire-hydrants on the nearest building by an enamelled iron tablet with the letter "H" inscribed thereon, and Mr. Ross urges that that system should be introduced into the City. As to stop-cocks for shutting off the gas supply, there was some doubt as to whether it would be an advantage, in the case of fire, that either the fire brigade or the workmen of the gas company should have means of readily cutting off the gas without having to enter the premises. It would be a source of danger if stop-cocks were placed outside buildings, for evil-disposed persons might turn off the gas and extinguish all the lights, and the turning-on of the gas again might lead to serious accidents. There are 27,827 houses in the City, and it is a matter for consideration whether stop-cocks on the footways might not in time become, by getting slippery, a serious source of danger and inconvenience to pedestrians. There are altogether 35 fire-alarms fixed in the City, all fixed and maintained by the Post office. Indicators might be placed on adjacent lamps without much expense.

### ROYAL INSTITUTE OF BRITISH ARCHITECTS.

#### THE ANNUAL ELECTION OF OFFICERS.

At a business meeting of the Institute held on Monday night the Council for the year of office 1898-99 were declared to be duly elected as follows:—

President:—\*Professor Aitchison, R.A.  
Vice-Presidents:—\*William Milner Fawcett, M.A.Cantab., F.S.A.; \*Henry Louis Florence; \*Ernest George; and \*Edward Augustus Gruning.

Hon. Secretary:—\*William Emerson.  
Members of Council:—\*John Belcher; \*Thomas Blashill; \*James Brooks; \*John McKean Brydon; \*William Douglas Caröe, M.A.Cantab., F.S.A.; \*Campbell Douglas (Glasgow); \*John Alfred Gotch, F.S.A. (Kettering); \*Alexandra Graham, F.S.A.; \*Benjamin Ingelow; \*Edward William Mountford; \*Berensford Pite; \*John Slater, B.A.Lond.; \*Percival Gordon Smith; \*Richard Phené Spiers, F.S.A.; \*Henry Heathcote Statham; \*Leonard Stokes; \*Paul Waterhouse, M.A.Oxon.; and \*Aston Webb, F.S.A.

Associate - Members of Council:—\*Arthur Smyth Flower, M.A.Oxon., F.S.A., and *Henry Thomas Hare*.

Representatives of Allied Societies:—\*Robert Isaac Bennett (Manchester Society); \*William Larkins Bernard (Bristol Society); \*Albert Nelson Bromley (Nottingham Society); \*John James Burnet, A.R.S.A. (Glasgow Institute); \*Thomas Drew, R.H.A. (Royal Institute of Ireland); \*Charles Busted Fowler (Cardiff, South Wales, and Monmouthshire Society); \*James Hine (Devon and Exeter Society); \*Leslie Ower (Dundee Institute); and *Albert Edwin Sawday* (Leicester and Leicestershire Society).

Representative of the Architectural Association (London):—\*George Halford Fellowes Pryme.

#### THE STANDING COMMITTEES.

The following Fellows and Associates were declared duly elected to serve on the respective Standing Committees for the ensuing year of office, viz.:—

#### ART STANDING COMMITTEE.

Fellows:—\*John Macvicar Anderson, F.R.S.E.; \*James Brooks; \*John McKean Brydon; \*William Douglas Caröe, M.A.Cantab., F.S.A.; \*Ernest George; \*Edward William Mountford; \*Berensford Pite; *Henry Heathcote Statham*; \*Alfred Waterhouse, R.A., LL.D.; and \*William Young. Associates:—\*Robert Shekleton Balfour; \*Owen Fleming; \*James Sive-wright Gibson; \*Henry Thomas Hare; \*George Campbell Sherrin; and \*John William Simpson.

#### LITERATURE STANDING COMMITTEE.

Fellows: \*Henry Louis Florence; \*Alexander Graham, F.S.A.; \*Benjamin Ingelow; John Tavernor Perry; \*William Alfred Pite; \*Sydney Smirke; \*Richard Phené Spiers, F.S.A.; \*Henry

Heathcote Statham; \*Paul Waterhouse, M.A. Oxon.; and *Ralph Selden Wornum*. Associates: \*Arthur Thomas Bolton; \*Arthur Smyth Flower, M.A.Oxon., F.S.A.; \*Andrew Noble Prentice; \*Ravenscroft Elsey Smith; \*Leslie Waterhouse, M.A.Cantab.; and \*Percy Scott Worthington, M.A.Oxon.

#### PRACTICE STANDING COMMITTEE.

Fellows: \*Thomas Batterbury; \*Samuel Flint Clarkson; \*Thomas Harris; *George Hubbard*; \*Alexander Henry Kersey; \*Joseph Douglass Mathews; \*Walter Hilton Nash; \*James Osborne Smith; *Charles James Smithem*; and \*Edmund Woodthorp, M.A.Oxon. Associates: \*William H. Atkin-Berry; \*Charles Henry Brodie; \*Francis Thos. Wilberforce Goldsmith; \*Herbert Hardwicke Langston; \*Augustus William Tanner; and *William Henry White*.

#### SCIENCE STANDING COMMITTEE.

Fellows:—\*Lewis Angell, M.Inst.C.E.; *Hampden William Pratt*; \*John Salmon Quilter; \*Herbert Duncan Searles-Wood; \*William Howard Seth-Smith; *Percival Gordon Smith*; *Alfred Saxon Snell*; \*Lewis Solomon; \*William Charles Street, Assoc.Inst.C.E.; and \*Benjamin Tabberer. Associates:—\*Sydney Benjamin Beale; \*Henry William Burrows; \*Max Clarke; \*Bernard John Dicksee; \*Matthew Garbutt, Assoc.-M.Inst.C.E.; and \*George Pearson.

Auditors:—Messrs. *Zeph. King and Frederick William Marks*.

#### THE PROFESSIONAL PRACTICE AS TO THE CHARGES OF ARCHITECTS.

The Council submitted the following revision of the well-known "Schedule" of professional charges sanctioned by the Institute as far back as 1872, and confirmed at a general conference of architects of the United Kingdom held in that year. By reference to the existing schedule, it will be seen that the document is to a very large extent recast, and the number of clauses is reduced from 20 to 18, while all reference to the terms of payment adopted by H.M. Office of Works is omitted, and Ryde's scale of charges for the compulsory acquisition of property is introduced. The amounts of the charges are not materially altered, but the particulars are rendered more explicit than in the existing document.

1. The usual remuneration for an architect's services except as hereinafter mentioned, is a commission of 5 per cent. on the total cost of works executed [under his directions, except as to approving plans and valuing property of great value. Such total cost is to be valued as though executed by a builder with new materials.] This commission is for the necessary preliminary conferences and sketches, approximate estimate when required (such, for instance, as may be obtained by cubing out the contents), the necessary general and detailed drawings and specifications, one set of tracings and duplicate specification, general superintendence of works, examining and passing the accounts, exclusive of measuring and making out extras and omissions.\* The clerk of the works should be appointed by the architect, his salary being paid by the client.

2. This commission does not include [the payment for services rendered in connection with negotiations relating to the site, or in surveying and taking levels, making surveys and plans of buildings to be altered, making arrangements in respect of party-walls and right of light, or for drawings and correspondence with local and other authorities, or consequent on the failure of builders to carry out the works, for services in connection with litigation or arbitration, or in the measurement and valuation of extras and omissions. For such services additional charges proportionate to the trouble involved and time spent are made.]

3. In all works [of less cost than £1,000, and in works requiring designs for furniture and fittings of buildings, or for their decoration with painting and mosaics, sculpture, or stained glass, and other like works, and in cases of alterations and additions to buildings] 5 per cent. is not remunerative, and the architect's charge [is regulated by special circumstances and conditions.]

4. When several distinct buildings [being repetitions of one design] are erected at the same time from a single specification and one set of drawings and under one contract, the [usual] commission [may] be charged on the cost of one such building, and a modified arrangement made in respect of the others; [but the arrangement does not apply to the duplication of parts in one building undertaken, in which case the full commission is to be charged on the total cost.]

5. If the architect should have drawn out the approved design complete, with plans, elevations, sections, and specification, the charge is 2½ per cent. upon the estimated cost. If he should have procured tenders in accordance with the instructions of his employer, the charge is ½ per cent. in addition. [These charges are exclusive of the charge for taking out quantities. Preliminary sketches and interviews, where the drawings are not further proceeded with, are to be charged for according to circumstances.]

6. The architect is entitled during the progress of the works to payment [by instalments] on account at the rate of 5 per cent. on the amount of the certificates when granted, or alternatively on the signing of the contract [to half the commission on the amount thereof], and the remainder by instalments during their progress.

\* This sentence is incorporated in paragraph 11 of the existing schedule.

7. Should the client, having approved the design and after the contract drawings have been prepared, require material alterations to be made, whether before or after the contract has been entered into, an extra charge is made [in proportion to the time occupied in such alterations.]

8. The charge per day depends upon an architect's professional position, the minimum charge being three guineas.

9. The charge for taking a plan of an estate, laying it out, and arranging for building upon it, is regulated by the time, skill, and trouble involved.

10. For setting out on an estate the position of the proposed road or roads, taking levels, and preparing drawings for roads and sewers, applying for the sanction of local authorities, and supplying all necessary tracings for this purpose, the charge is 2 per cent. on the estimated cost. For subsequently preparing working drawings and specifications of roads and sewers, obtaining tenders, supplying one copy of drawings and specification to the contractor, superintending works, examining and passing accounts (exclusive of measuring and valuing extras and omissions), the charge is 4 per cent. on the cost of the works executed, in addition to the 2 per cent. previously mentioned.]

11. For letting the several plots in ordinary cases the charge is a sum not exceeding a whole year's ground rent [but in respect of plots of great value a special arrangement must be made.]

12. For [approving plans submitted by the lessee, and for] inspecting the buildings during their progress, so far as may be necessary to insure the conditions being fulfilled, and certifying for lease, the charge is a percentage not exceeding [1½] per cent. up to £5,000, and above that by special arrangement.

13. For valuing freehold, copyhold, or leasehold property the charge is—

On £1,000 .....	1 per cent.
Thence to £10,000 .....	¾ " "
Above £10,000 .....	[½ " " on residue]

[In valuations for mortgage, if an advance is not made, one-third of the above scale. The minimum fee is three guineas.]

14. For valuing and negotiating the settlement of claims under the Lands Clauses Consolidation Act or other Acts for the compulsory acquisition of property, the charge is on Ryde's scale, as follows:—

#### ON AMOUNT OF SETTLEMENT, WHETHER BY VERDICT, AWARD, OR OTHERWISE.

Amount.	Gs.	Amount.	Gs.	Amount.	Gs.	Amount.	Gs.
£ 100	5	£ 2,400	25	£ 5,400	40	£ 8,400	55
200	7	2,600	26	5,600	41	8,600	56
300	9	2,800	28	5,800	42	8,800	57
400	11	3,000	29	6,000	43	9,000	58
500	13	3,200	30	6,200	44	9,200	59
600	14	3,400	31	6,400	45	9,400	60
700	15	3,600	32	6,600	46	9,600	61
800	16	3,800	33	6,800	47	9,800	62
900	17	4,000	34	7,000	48	10,000	63
1,000	18	4,200	35	7,200	49	11,000	64
1,200	19	4,400	36	7,400	50	12,000	73
1,400	20	4,600	37	7,600	51	14,000	83
1,600	21	4,800	38	7,800	52	16,000	93
1,800	22	5,000	39	8,000	53	18,000	103
2,000	23	5,200	40	8,200	54	20,000	113
2,200	24						

Beyond this half a guinea per cent.

The above scale is exclusive of attendances on juries or umpires, or at arbitrations, and also of expenses and preparation of plans.]

15. For estimating dilapidations [and furnishing or checking a schedule of same], the charge is 5 per cent. on the estimate, but in no case less than two guineas. [For services in connection with settlement of claim by arbitration or otherwise, extra charges are made, under Clause 8.]

16. For inspecting, reporting, and advising on the sanitary condition of premises, the charge must depend on the nature and extent of the necessary services rendered.]

17. In all cases travelling and other out-of-pocket expenses are paid by the client in addition to the fees. [If the work is at such a distance as to lead to an exceptional expenditure of time in travelling, an additional charge is made under Clause 8.]

18. When an architect [takes out and] supplies to builders quantities on which to form estimates for executing his designs, he should do so with the concurrence of his client, and it is desirable that the architect should be paid by him rather than the builder, the cost of such quantities not being included in the commission of 5 per cent.

The suggested alterations were discussed in detail, and the debate was eventually adjourned to a special business meeting to be held on Monday, the 27th inst.

Preaching at the temporary church of St. Ambrose, Pershore-road, Edgbaston, Canon Strange announced on Sunday night that the Misses Stokes, who have already given £2,000 to the building fund, have decided to bear the whole of the structural cost of the new church over and above the sum which has been raised in the parish. The church will thus be a building complete, so far as structure goes, not merely with chancel and nave, aisles and transepts, but with tower and spire and tubular bells, besides the organ and east window, already given by these ladies.

\* In existing schedule ½ per cent.

+ In existing schedule, by special arrangement.

\* Signifies re-election. New members' names printed in italics.



CHAMBER OF COMMERCE BUILDINGS,  
CLEVELAND, OHIO.

AMONG the many clever buildings erected during the past twenty years in America, few have surpassed in merit those designed by Messrs. Peabody and Stearns, the well-known architects, of Boston. To-day we give a view of one of their more recent city buildings—the Chamber of Commerce, Cleveland. The difficulty of investing a vast façade like this with distinguishing character is a very real one when floor upon floor, each of about the same height, has to be provided for. The fenestration necessarily has to follow very nearly the same lines as the apartments within, and the variety of treatment which follows upon a diversity of internal arrangement is wanting in such edifices as hotels and apartment houses or office buildings. The architects in the instance now illustrated have very ingeniously overcome the inevitable monotony so frequently observable in elevations where the conditions of several floors are similar, and Messrs. Peabody and Stearns have inspired their façades with breadth and dignity by pleasingly contrasting the strongly-marked horizontal lines of the base with the vertical lines of the main portion of the fronts. These, again, are crowned by a boldly-managed cornice. The loggia of the top story, it is true, was rendered possible by the increased height of that floor, and thereby great advantage, of course, is obtained, an advantage which would have been lost had the upper part of the building been devoted to small apartments. The sculpture fronting the mezzanine floor is a distinct acquisition, and although there may be nothing, after all, very specially original in the detail of this building, its design is at once modern and architectural in style, its effect being obtained without following any exact period or recognised historical mode. Its parts are somewhat elaborate, notwithstanding the simplicity of its general outlines, and we intend to illustrate a sheet of its details because of their merit, which we have thus endeavoured to indicate. The *American Architect*, to whom we are indebted for this view, has on more than one occasion enabled us to become acquainted with works by the same architects.

## OBITUARY.

THE death is announced of an old and respected townsman of Wolverhampton, Mr. JAMES READ VEALL, architect, which occurred on the 27th May at Beewood. Coming originally from the Eastern Counties, he entered, in the early forties, the office of the late Mr. Edward Banks, of Wolverhampton, and in 1851 established himself in business with Mr. T. R. Meyrick, whose early death severed what appeared to be a promising connection. Some of the principal of his early works were the old town hall, Mr. Henry Underhill's residence at Pirton; Mr. F. Walton's, St. Cuthbert's, Albrighton; Mr. C. Clarke's, Muchall, Penn; and Mr. G. Perry's houses at Stockwell End. His later works comprise the gas company's offices, Darlington-street; Messrs. E. Webb and Son's offices and warehouses, Wordsley; almshouses, Leicester; the Victoria Nursing Institute, Wolverhampton, also sundry voluntary schools, including those in Steelhouse-lane. He also carried out extensive works for the Wolverhampton and the Cannock Boards of Guardians. The agricultural hall was another of his works. The roof of that building was at the time unique in its way, and has since been adopted elsewhere. Amongst the deceased's other works were residences at Codsall, Albrighton, Lapley, Penkridge, together with a few vicarages, mission churches, &c. During the last few years he was one of the surveyors for the diocese of Lichfield in the Archdeaconry of Stafford. He was a man of extensive reading and varied attainments, of sound judgment, and his taste for archaeology led him to publish in 1889 a book illustrative of old houses in Wolverhampton and neighbourhood. The deafness from which he suffered precluded him from taking an active part in public affairs. His business will be carried on by his second son, Ashton Veall, whom he took into partnership a few years ago. He leaves a daughter and four sons.

THE German painter, Professor FRIEDRICH GESSELCHAP, whose body was found on Friday near Rome hanging from a tree, had been suffering for some time from depression caused by an injury to his knee, in consequence of which the doctors advised amputation of the leg. Professor

Geselchop, who was born in 1835, in Wesel, and studied at the Dresden and Düsseldorf Academies, was best known as a fresco painter who imitated the Classical style. Some of his pictures adorn the walls of the Arsenal in Berlin; but his manner has long been regarded as antiquated and artificial. He had lately been greatly depressed owing to his physical inability to carry out a commission which he had received for fresco paintings on the ceiling of the Friedenskirche in Potsdam.

## COMPETITIONS.

SUNDIAL MODELS.—The first prize in the competition for models for a sundial, instituted by Mr. Thomas H. Kelly, of New York, and carried on under the auspices of the National Sculpture Society, has been awarded to Mr. Charles A. Lopez, of New York; the second prize to Mr. W. C. Maynard, of Brooklyn; a first mention to a design whose author is not known; a second mention to Mr. Hall Winters Morris, of New York; a third mention to Miss Janet Hall Scudder, of New York, and a fourth mention to Mr. J. M. Kimball, of Brooklyn. The competition was for a sundial, standing on a pedestal in open ground; and Mr. Kelly offered 500dols. as the first prize, and 250dols. as the second. Twenty-eight designs were submitted, among them being some from England.

WINCHESTER.—The city corporation, at their meeting on Thursday in last week, considered the report of Mr. Jones, the assessor on the designs for public baths, who had awarded the premiums voted by the council as under:—"Cleanliness," first premium, £25; "Aqua No. 1," £15; and the third place to "Comme il Faut." The names of the premiated competitors were respectively Messrs. Lonsdale and Harrison, Compton-terrace, Highbury; Messrs. Hall, Cooper, and Davis, Scarborough, and 21, Old Queen-street, Westminster; and Mr. H. A. Cheers, Twickenham, London. The first premiated plan would, in its complete form, involve an outlay of £10,329; with modifications, either £8,691 or £7,181. "Aqua" was pretty nearly the same, and "Comme il Faut" £6,000 for the whole—two swimming and a Turkish bath, and "slippers." The first plan was adopted by the council, but subject to modifications to reduce the entire outlay to £7,000. The matter was referred again to the Committee on baths, who will communicate with the architects, and report again to the council. The premiums were ordered to be paid, and all plans save the adopted one returned. A curious item arose in connection with the plans—viz., that by some means the contents of one of the bath documents had become known, and it was recommended prompt action should be taken to insure greater secrecy. The town clerk said no person in his office had communicated with the public on the matter, and he should take extra precautions in future with all private documents.

## CHIPS.

At the Mart, Tokenhouse-yard, E.C., on Tuesday, Wray Castle, situated on the banks of Lake Windermere, was sold for £25,000. The estate covers an area of about 830 acres.

The Earl of Jersey, Colonel Boughey, R.E., and H. A. Steward, sitting as commissioners under the Light Railways Act, opened an inquiry at Hastings on Tuesday into the application of Mr. Murphy for sanction to a proposed tramway scheme for the borough. A strong opposition was offered by a committee representing many tradesmen, property owners, and influential residents, and the trustees of the Eversfield Estate, the London, Brighton, and South-Coast Railway Company, and the Office of Woods and Forests also opposed the application.

A well-written article, "A Morning on the Island of St. Helena," from the pen of Mr. Harry Hems, appears in Tuesday's issue of the *Western Daily Mercury*.

The proceedings of the meeting of the Association of Municipal and County Engineers in the Nidd Valley, near Pately Bridge, Yorkshire, on Saturday, were marred by the sudden death of Mr. William Tulley, surveyor, of Rothwell, near Leeds. The meeting was especially held for the purpose of visiting the works which the Bradford Corporation have in progress in the Nidd Valley for the supply of water to Bradford, and was attended by municipal engineers from all parts of the country. Whilst in a contractor's train along a light railway on the higher slopes of the valley, Mr. Tulley fell off the truck on which he was riding, and was picked up dead.

## PROFESSIONAL AND TRADE SOCIETIES.

EDINBURGH ARCHITECTURAL ASSOCIATION.—On Saturday the members of this association, to the number of between 40 and 50, accompanied by the president, Mr. Thomas Ross, and the secretary, Mr. Hunter Crawford, enjoyed their annual excursion, the place visited being Alloa. Leaving the Waverley Station at 9.10 a.m. the town of yarn was reached shortly after 10 o'clock. The excursionists at once proceeded to inspect the public baths and gymnasium, the gift to his native town of Mr. John Thomson Paton. Mr. John Burnett, A.R.S.A., Glasgow, the architect of the building, acted as guide to the party, and explained all necessary details. Here the Provost said a few words of welcome to the visitors, which were acknowledged by Mr. Ross. Alloa Park and mansion were next visited, and through the kindness of the Earl of Mar and Kellie, the excursionists were conducted over Alloa House and the beautifully laid out garden and grounds. His lordship personally undertook this duty, and afterwards entertained the company to lunch in old Alloa Tower. In the afternoon visits were paid to two of the most recent additions to the gentleman's seats of the district—viz., Greenfield House, the residence of ex-Provost Thomson, and Inglewood, the residence of Mr. Forrester Paton (the architect of both), Mr. Sydney Mitchell, Edinburgh, giving explanations. The company also visited the town-hall and public library, and Alloa parish church. Mr. Forrester Paton entertained the excursionists to tea in the Museum Hall.

THE EDINBURGH ARCHITECTURAL SOCIETY.—At the last meeting of this society, a lecture, entitled "Grammar of House Planning," was delivered by Mr. J. J. Henderson, representative of the Dundee Institute of Architecture, Science, and Art. Mr. William N. Cumming, A.R.L.B.A., the President, occupied the chair. Mr. Henderson treated his subject from a practical point of view, dealing first with general principles, site, prospect with a view to health, nature of soil, drainage, &c. The lecturer drew particular attention to the necessity of frequently consulting the client as to his requirements during the progress of the design. He gave some very interesting notes on constructional details of much value to architects in planning houses. He then passed on to point out the value of ventilation, recommending that all windows should be kept as near the ceiling of rooms as possible.

In the House of Commons, on Tuesday, Mr. Lough asked leave to bring in a Bill to amend the Metropolitan Management Acts, and it was read a first time.

Mr. Sandford Fawcett, Local Government inspector, held an inquiry, on Friday, regarding an application by the Northwich Urban Council for sanction to borrow £2,000 to put eight private streets into such a condition that they can be taken over as public thoroughfares. Several of the roads have been like quagmires for years. Nearly £2,000 have been expended on similar work. Notices for ten other streets have been given. There was no opposition.

Mr. James Smith, J.P., timber merchant, of Balliol House, Balliol-road, Bootle, died suddenly on Monday. The deceased, after transacting some business at home, suddenly expired. Mr. Smith was 68 years of age, and at one time was a member of the Bootle Town Council.

Earl Brownlow presided, on Friday, over a Lincolnshire county meeting, held at the Guildhall, Lincoln, for the purpose of promoting a subscription for a Lincolnshire memorial of the late Lord Tennyson. On the motion of the Bishop of Lincoln, seconded by the mayor of that city, it was resolved that the memorial should take the form of a statue, to be erected on the best site obtainable in Lincoln.

A committee was formed last autumn to commemorate in some permanent form the completion of his twenty-fifth year of office by the present head master of Bromsgrove School, Mr. Herbert Millington. It was resolved to raise by subscription £1,250, and to expend this sum on a "Millington Laboratory," comprising physical and chemical laboratories, and carpenters' and metal-workers' shops. The architect selected was Mr. Lewis Sheppard, of Worcester, the builders Messrs. J. and A. Brazier, of Bromsgrove, who designed and built "Lyttelton House" for the school in 1893. This building, which is in the English Renaissance style, will be opened on Wednesday, July 27, by the Bishop of Worcester. A boarding-house is also being erected on a site contiguous to the school playground, and will be opened in May next year.

## Building Intelligence.

**BANGOR, Co. DOWN.**—The foundation-stone of Hamilton Road Presbyterian Church was laid last week. The plan of the church is horseshoe shape. The section now in course of erection will accommodate about 400 on the ground floor, and about 300 in the galleries, and the next section, in the form of a second transept, will give accommodation for about 300, so that the church will ultimately seat a congregation of 1,000. The front vestibule has inner lobbies, right and left, to the aisles of the church, and off these doors to gentlemen's and ladies' cloakrooms. As no schools or lecture-halls are proposed for the present, the plans have been prepared so that the second section can be erected immediately, and utilised in the meantime as lecture-hall, committee-room, vestry, and schoolroom, a screen wall dividing the two blocks. This screen wall can be taken down at any time and the whole thrown into the church, and the lecture-hall and schoolroom erected in an attached building, for which there has been ground secured. The galleries will be carried on steel cantilever girders, and the roof trusses will also be of steel. The interior woodwork will be of pitch-pine, and the walls of the building in local stone, with Scrabo stone for dressings. A corner tower has been provided, to which it is possible to add a stone spire in the future. The building has been designed in the Perpendicular period. The architect is Mr. Wm. J. W. Roome, M.S.A., Belfast. The contract is in the hands of Mr. James Colville, builder, Bangor, and the clerk of works is Mr. Bailey.

**EDINBURGH.**—In 1885 Mrs. Traquair decorated with symbolical pictures the small mortuary of the old Sick Children's Hospital, Lauriston-lane, Edinburgh. When the hospital was removed to another site, and it became necessary to pull down the old building to make way for the new infirmary ward, an attempt was made to cut them out of the walls with a large measure of success, some of the best of the old decorations being now incorporated in the walls of the mortuary of the new hospital, Sciennes-road. These include a panel, called "Maternity"; another symbolical design of the Cup of Life, with mortals drinking from it; and a larger group representing the Bridge of Life. Mrs. Traquair has decided, as a labour of love, to complete the decoration of the present walls. Having for central panel the "Maternity" group, Mrs. Traquair has worked it into a design, the upper parts of which are filled with child angels, in various stages of spiritual development. On the east and west walls there are six large red-winged figures, representing the angels of creation. They stand on spheres, which suggest the separate acts of creative power. Behind the seraphs the walls are divided into six horizontal zones, representing terrestrial and celestial objects. The large panel of the Bridge of Life, with its angel figures, nearly filled the south wall. All that was necessary to complete the decoration of this part of the chapel was a broad arabesque border, in which symbols of Time and Eternity have been interwoven. The roof has been treated in cerulean blue, with gold circle ornament. The dominant notes in the decorative scheme are gold and blue and green and grey.

**INVERNESS.**—The Tweedmouth Memorial Chapel, erected by the Dowager Lady Tweedmouth in the grounds of the Northern Infirmary, was opened on Saturday. Built of dressed freestone, the chapel is designed in a Late Pointed phase of Scotch Gothic. It is cruciform in design, with a steep-pitched roof covered with grey slates, and is surmounted in the centre by a fleche of oak, and slated, rising to 50ft. above the ground. The south window has three lights and tracery, and the windows in the two transept gables are triple lancets; while a rose window, about 10ft. in diameter, gives light from the north end. The nave is 44ft. by 18ft., whilst in either side there is a transept, separated from the main area by wrought-iron gates and curtains, for use by worshippers of the Roman and Anglican communions. The whole of the furnishings are in oak. The inside walls are of polished freestone, and the windows are all deeply moulded, the jambs and mullions being finished with shafts of grey Kilkenny marble and carved capitals. The roof is also in oak, panelled, and the arched ribs rising from the carved couples divide the interior into three bays. The floor of the chapel is laid with oak parquetry, stained and polished.

A corridor, 6ft. wide, connects the church with the infirmary. Messrs. Ross and Macbeth, Inverness, were the architects.

### CHIPS.

Colonel J. T. Marsh, R.E., of the Local Government Board, held a public inquiry, on Thursday in last week, relative to the application of the urban district council for sanction to borrow £2,000 for the purpose of lighting the promenade by electricity.

In connection with the Phoenix Lodge, 904, of Freemasons, the dedication ceremony took place on Friday of new Masonic buildings which have been erected in High-street, Rotherham, by Bro. Henry P. Gough, a townsman.

An addition to the series of the stained-glass windows in St. Cuthbert's Parish Church, Edinburgh, was unveiled on Sunday. It has been placed under the gallery in the south transept. The subject is a figure of Christ breaking bread, as suggestive of the Communion. The subject is inclosed in a framework of architectural ornament. The details harmonise with the other windows in the church.

The new stables and other buildings just erected in Græne-street, Glasgow, for the Cleansing Department of that city were opened on May 31. They have been built at a cost of £14,000, from plans by Mr. Wheatley.

The Newport-Pagnell Urban District Council have accepted the tender of Messrs. G. Waller and Sons, of Stroud, for the new engines and pumps, designed by Messrs. D. Balfour and Son, of London and Newcastle, required at the town waterworks, which, owing to their increased power, will enable the supply to be delivered in six hours.

The scheme of water supply submitted by the Easington Rural District Council for Castle Eden Colliery has been approved by the Local Government Board. The water is pumped at Wingate from the sand-feeder up into the reservoir, and then is to be conveyed a distance of three miles in cast-iron main, when it will be distributed over the town. The scheme has been designed by Messrs. D. Balfour and Son, of London and Newcastle.

Alterations are being made to Messrs. Coomb's Brewery, Radstock, and special consideration has been given to the ventilation, which will be carried out on the Boyle system.

Mr. S. Fawcett, inspector of the Local Government Board, held an inquiry at Wilmslow on Friday with reference to the application of the district council for sanction to borrow £1,100 for main road and private street improvements.

The competition for the Legislative Palace of the City of Mexico has been decided by the award of the first prize, of 15,000dol., to Mr. Adamo Boari, an Italian architect, for some years resident in Chicago. The second prize has been awarded to another Chicago architect; but his name is not yet announced. The building is to cost five million dollars.

Colonel W. R. Slacks, M.E., Local Government Board inspector, held an inquiry at Shifnal, on Tuesday, as to the application of the district council for sanction to borrow £3,300 for purposes of sewage and sewage disposal, and £3,745 for purposes of water-supply for one special district of their area.

The Light Railway Commissions held an inquiry at Chatham, on Thursday, Friday, and Monday, into an application made by the Chatham, Gillingham, and District Electric Railways Company for powers authorising them to construct a series of light railways, or tramways, between Chatham and New Brompton, and between the former borough and certain populous suburbs. The proposal is to establish electric street tramways on the overhead trolley wire principle, and the promoters have undertaken to contribute about £10,000 towards the widenings required at various points. The local authorities of both towns supported the application, but had stipulated that they should have the option of purchasing the undertaking at the expiration of 42 years. The Earl of Jersey said the Commissioners were prepared to recommend that the order be granted.

Mr. J. T. Marsh, C.E., of the Local Government Board, held an inquiry at Llandudno, on Friday, as to the application of the urban district council for a loan of £16,000, the estimated cost of erecting new municipal buildings on land in Lloyd-street, valued at £4,500, and given to the town by Lord Mostyn. The clerk said the scheme had been under consideration four years, and that the plans of Mr. Silcock, of Bath, were accepted as the result of a competition. The present offices were utterly inadequate for the purposes of the council. Lord Mostyn's agent, Mr. Pickering, had written in terms of disapproval of the plans of the new buildings as not being of a sufficiently imposing appearance, and stating that the architect had evidently been limited in the matter of funds.

## Engineering Notes.

**NOTTINGHAM.**—In connection with the development of the Clifton Estate on the north side of the Trent at Nottingham, the first pile has been driven of the Trent Bridge Embankment, by which a new roadway will be provided. The road will be 1½ miles in length, extending from Trent Bridge to Wilford Bridge, and will consist of a carriage-way 36ft. wide, with two footpaths on each side, separated by grass verges, upon which trees will be planted. The footpath nearest the foreshore of the river will be 15ft. wide, and the total span of the road, including footpaths and grass verges, will be about 90ft. From the south edge of the 15ft. footway, running down to the river, a grass foreshore will be laid of easy slope, terminating in seven concrete steps extending the whole length, at the foot of which will be driven a wooden piling. On this foreshore will be planted several rows of trees, and the area will be open for the recreation of children. The road will follow the windings of the river, and will be formed at a sufficient height to be above flood level, so as to be available for use in all states of the river. A large amount of the material required to elevate the road to the requisite height will be dredged from the Trent. The chief contract has been let to Mr. A. Kellett, of Manchester, and the kerbing, channelling, asphalt, and the making of the road will be executed by the Nottingham Town Council staff. The works have been designed by, and are being carried out under the direction of, the Nottingham city engineer, Mr. A. Brown.

The annual meeting of the Royal Architectural Museum, Great Tufon-street, Westminster, will be held this (Friday) afternoon at four p.m., under the presidency of the Duke of Westminster, when the art studios, just added to the buildings from the designs of Messrs. Lee and Pain, will be thrown open for inspection. All architects are cordially invited to attend.

Mr. W. H. Clary, assistant borough surveyor of Derby, has been elected borough surveyor for Sutton Coldfield, vice Mr. C. F. Marston, resigned. Mr. Clary's salary will be £300 a year, and he will have to devote his whole time to the services of the corporation.

During 1897 a Leeds firm purchased for the sum of £30,000 the large tract of land at Scarborough, known as the Woodhall Estate, on the north side of the town. The new owners have already commenced operations in connection with the erection here of some 1,200 new houses, at rents varying from £12 to £15 a year.

Arrangements are in progress for the annual convention of the National Master Plumbers' Association which is to take place in Quebec the latter part of this month. The president is Mr. Joseph Wright, of Toronto.

The Venerable Melville Horne Scott, Archdeacon of Stafford, and Canon of Lichfield Cathedral, died on Friday. The deceased, who was born at Gawcott, Buckinghamshire, in 1827, was a son of the Rev. Thomas Scott, M.A., incumbent of that parish, was a direct descendant of Thomas Scott, the great commentator, and a younger brother of the late Sir Gilbert Scott, R.A.

At a meeting of the Society of Biblical Archaeology, held on Tuesday evening, at Great Russell-street, London, Sir H. H. Howorth, K.C.I.E., read a paper on ancient picture writing.

At Cobholm, Great Yarmouth, the foundation-stone has been laid of a new church about to be erected from plans by Mr. Sidney Rivett.

Mr. Charles White, a well-known Liverpool engineer, died at his residence in Alexandra-road on Friday at the age of 71 years. Born in Yorkshire, he had to do with some of the first railways constructed in this country by George Stephenson. About 30 years ago he undertook the offices of chief engineer and estate manager to the Leeds and Liverpool Canal Company, but through ill-health was compelled last Christmas to relinquish the former position, which was taken by his son. Mr. Robert H. White.

The new athletic ground at Tunbridge Wells has been opened by the Marquis of Abergavenny. The ground affords accommodation for 12,000 people, and covers 12½ acres of land, which has been leased to an association at £7 per acre by the Marquis of Abergavenny. In addition to a cricket pitch, there are a cycling track and a football ground, the whole of the works having been carried out by Mr. W. Roper, of Tunbridge Wells. The construction of the ground has necessitated the removal of 60,000 cubic yards of earth.

CONTENTS.

Keeping Pace ... 803  
 French Paintings at the Guildhall ... 803  
 Model Specifications. XVI. ... 804  
 Foundations as Applied to London Buildings and  
 Riverside Foundations ... 806  
 Ironwork at South Kensington Museum.—V. ... 809  
 Gasworks Machinery ... 809  
 The Collapse of a Basement Vault at Marylebone ... 810  
 BUILDING NEWS DESIGNING CLUB  
 The Building Trades Directory ... 810  
 Architectural Metal-Work ... 811  
 Art Metal Exhibition Awards ... 811  
 Protection against Fire in the City ... 811  
 Royal Institute of British Architects ... 812  
 Chamber of Commerce Buildings, Cleveland, Ohio ... 813  
 Obituary ... 813  
 Competitions ... 813  
 Professional and Trade Societies ... 813  
 Building Intelligence ... 814  
 Engineering Notes ... 814  
 THE BUILDING NEWS DIRECTORY ... 814  
 Our Illustrations ... 815  
 Intercommunication ... 834  
 Statues, Memorials, &c. ... 834  
 Water Supply and Sanitary Matters ... 834  
 Legal Intelligence ... 835  
 Parliamentary Notes ... 835  
 Our Office Table ... 835  
 Meetings for the Ensuing Week ... 836  
 Trade News ... 837  
 List of Competitions Open ... 837  
 List of Tenders Open ... 837  
 Latest Prices ... 839  
 Tenders ... 840

ILLUSTRATIONS.

TOWN HALL, TAUNTON.—WROUGHT-IRON GATES, NEWNHAM  
 PADDON.—CHURCH TOWER, MONKS KIRBY.—ALL SAINTS,  
 BRIXWORTH.—DESIGNS FOR FURNITURE.—CLEVELAND  
 CHAMBER OF COMMERCE, OHIO.—STABLING AND COACH-  
 MAN'S COTTAGE.

Our Illustrations.

TAUNTON TOWN HALL COMPETITION: SELECTED  
 DESIGN.

Messrs. SAMSON AND COTTAM, architects, Taunton, are the authors of this design, which has been chosen for execution, and they were awarded the first premium of £100. The second prize of £50 was given to Mr. J. M. Brydon, F.R.I.B.A., of London, for the set marked "N," and the third of £30, was taken by Mr. H. T. Hare, of London, for the set marked "L." The other competitors were as under:—Set B, Messrs. Tapper and Crouch, London; set C, Messrs. Silcock and Reay, Bath; set D, Mr. R. Knill Freeman, Bolton; set E, Messrs. Gibson and Russell, London; set F, Messrs. Mallows and Grocock, of Bedford; set H, Mr. W. H. Crease, of Bristol; set I, Mr. G. Elkington, London; set J, Messrs. Murray and Foster, London; set K, Mr. C. Henman, London. The following description, drafted from particulars, has been sent us by the authors of the selected design. The building is in the Renaissance style, and possesses many notable features. When erected on the Parade it will form a distinct ornament to the town, and will at the same time provide the convenient rooms and offices which are so necessary to the municipality. A remarkable and novel feature is a triforium on each side of the hall. The arrangements adopted in the design can best be gathered by a consideration of the plans of the several floors. It may be pointed out that on the ground floor the market is placed in the centre of the north front, facing the Parade, and that the main entrance to the town-hall and the guildhall is placed to the east, while the offices, &c., of the trustees' present tenant are situate to the west of it. The arrangement of the east and west wings is so nearly symmetrical and equal in size, that it would be quite feasible, if thought desirable, without materially altering the principle on which the design is planned, to transpose them and to place the principal entrance and guildhall on the west of the block, so that they would come opposite the approach from Corporation-street, as well as High-street, North-street, &c. This may be thought more desirable, as the street is much wider here than on the east side. This, however, is merely a matter of arrangement and convenience of plan best adopted to meet the views and requirements of all parties, which can be adopted without departing from the spirit of the design. Great care has been bestowed on the proper planning of approaches and exits, which, it is believed, will be found convenient and safe. It is suggested that the two subsidiary staircases as a general rule should be used for exits only, though it might on certain occasions be useful to employ them for purposes of entrance, either as early

doors or approaches to reserved or cheap sides. Ticket offices and a men's and women's lavatory have therefore been shown in connection with them. Space has been left for the shops facing south, as directed. It is submitted that it might be advisable to omit one shop, and form a convenient approach to the market from the south in place of it. No lavatory accommodation has been provided in connection with the market and shops; should such provision be thought desirable, it is considered that it would practically amount to providing public lavatories, which would not only be beyond the scope of the scheme, but for which a better site could probably be found elsewhere in close proximity to, but not necessarily in connection with, the new buildings. A sentence may, perhaps, be devoted to indicating the method of construction which it is proposed to adopt in the roof and to carry the clock-turret. There will be two strong longitudinal steel lattice girders forming trussed purlins, which will do the duty of the transverse tie-beam trusses usually employed. These permit of the formation of a coved ceiling to the hall, and leave on either side a sort of triforium, or gangway, already referred to, which will have several important uses as it will give access to the clock-chamber and ventilating turret, also to the gutters and over the whole space between ceiling and roof for access to electric lighting or other wires. It will further permit of opening, closing, &c., the dormer windows without the employment of unsightly and unworkable cords or gearing, and consequently of the regulation of ventilation without disturbing the audience or diminishing the air space of the hall, and will to a great degree dispense with the use of ladders in decorating the hall. Strong steel cross-ribs will be introduced as required to complete the roof construction. The sum at disposal is not sufficiently large to permit of any great outlay upon the several façades of the new building. These have, therefore, been kept plain, and reliance for effect is placed upon the disposition of the several parts and a broad treatment of the whole mass. In view of the great distance from which the building, especially the north or principal front, can be seen, it is considered this will be found more truly artistic and effective than a treatment of the front in small parts and the elaboration of minute details. With regard to the materials to be employed, it is proposed that the front be constructed of red bricks in thin courses with Ham-hill stone or terracotta dressing. The roof will be slated. The internal walls and ceilings generally will be plastered, and the cornices and decorations are to be of wood, the whole of the staircases of fireproof construction in concrete. The stage, orchestra, and accessories generally are those usually provided in modern buildings of this description. Having regard to the various uses to which the hall is likely to be put, it is suggested that the sides and ceiling of the stage should be constructed of light framework made easily removable, giving ample space for wings and flies when the hall is to be used for theatrical performances. The question of heating and ventilation has been most carefully considered in preparing the scheme, though nothing is allowed for the former in the estimate appended. It is proposed to heat the new building by means of hot-water circulating pipes on the high pressure system, the heat being distributed by means of radiating coils fixed in suitable recesses beneath the windows or elsewhere as may be desirable. The ventilation will be induced by the introduction of warm air over these coils and by the extraction of the foul air at the ceiling level of the hall and guildhall and elsewhere, from which it will be taken out in shafts around smoke-flues and also through the dormers, and the flèche containing the clock as before described. It is submitted that the arrangements thus indicated will provide a well-warmed and ventilated building under all ordinary conditions. Mr. Edward W. Mountford, F.R.I.B.A., acted as professional referee, and his award was unanimously adopted. We hope shortly to illustrate the two other premiated designs.

WROUGHT-IRON GATES, NEWNHAM PADDON,  
 LEICESTERSHIRE.

JUST now, while the Art Metal-Work Exhibition is open at Westminster, an additional interest is given to any really fine examples of wrought iron. In any case it would be difficult to find a

more admirably-designed specimen of smith's work than the pair of gates of which we give a capital detail drawing to-day from the appreciative pencil of Mr. J. J. K. Phillips, to whom a National Bronze Medal was awarded for this very useful sheet. Structurally these gates are well contrived, and artistically the whole composition leaves nothing to be desired. The work is refined with boldly-conceived piers, while an exceedingly handsome skyline is made of the crowning feature surmounting the arched head of the gateway. In most modern productions the dominating outlines are often ill-considered and poor, while too much elaboration is not infrequently introduced into the wickets themselves. In this pair of gates simplicity itself is justly valued at its worth, so that by the advantage of contrast the stationary parts of the structure hold an enhanced importance in respect to scale as well as to richness of decorative effect. Note, for instance, the great value of the plain arched contour of the gates themselves, with their quiet and frequently repeating vertical lines, and when the gates are thrown back the unbroken curve of the soffit, so to speak, of the opening comes into even greater prominence, and looks extremely well. The gates were made towards the close of the last century, and were then erected at Berwick House, Shrewsbury, by the smiths who executed the work at Colebrook Dale. In 1873 they came into the hands of the Denbigh family, and are now standing at Newnham Paddox, Leicestershire.

CHURCH TOWER, MONKS KIRBY, LEICESTERSHIRE.

THE upper portion of this tower was restored by the late George Edmund Street, R.A. The lower parts are Late Decorated. Mr. A. E. Martin received a National Bronze Medal for this drawing as part of a series, all of which were of exceptional merit.

ALL SAINTS, BRIXWORTH.

THIS famous Saxon church, erected in the 7th century, is of national importance on account of its age. Mr. Martin, the author also of this Prize Medal sketch, has added to its value by writing upon the sheet the leading particulars of the history of the building. The plan also accompanies the view.

"BUILDING NEWS" DESIGNING CLUB: DINING-  
 ROOM OAK FURNITURE AND CHIMNEYPIECE.

(For description and award see p. 810.)

CHAMBER OF COMMERCE BUILDINGS, CLEVELAND,  
 OHIO.

(For description, see p. 813.)

STABLING AND COACHMAN'S COTTAGE,  
 ST. LEONARD'S.

MR. WILLIAM COOPER, of Hastings, is the architect of the block of stables with coachman's cottage, of which a view, with plan, accompanies these few notes. The building has recently been erected for Mr. W. Knighton, LL.D., at "Tileworth," Silverhill, St. Leonard's. Mr. Ashdown, of the same place, was the builder, the contract being completed for £480. The upper part is tile-hung, with roofs of the same material, the walling being in brick. The plan sufficiently exhibits the internal arrangements.

CHIPS.

The death occurred on Tuesday of Mr. Robert Townend Martin, C.E., superintendent of the Liverpool Corporation Waterworks, Rivington. He had been a sufferer from influenza. Deceased, who was about 60 years of age, leaves a widow and daughter. He had been in the service of the corporation about 30 years, and was appointed superintendent some six years ago. He was chairman of the Rivington Parish Council, and did much useful public work.

Messrs. Morrison and Mason, of Glasgow, have secured a contract for the extension of the Birmingham water supply. The contract price is half a million sterling.

The Rivers Committee of the Manchester Corporation have selected three gentlemen to advise them in the matter of sewage disposal—namely, Mr. Baldwin Latham, C.E., Dr. W. H. Perkin, professor of organic chemistry at Owens College, and Dr. Percy Frankland, of Birmingham.

The Birmingham Tame and Rea District Drainage Board have decided that application be made to the Public Works Loan Commissioners for a loan of £100,000 under the provisions of the Extension Act of 1897.



CHAMBER OF COMMERCE BUILDINGS, CLEVELAND, OHIO.



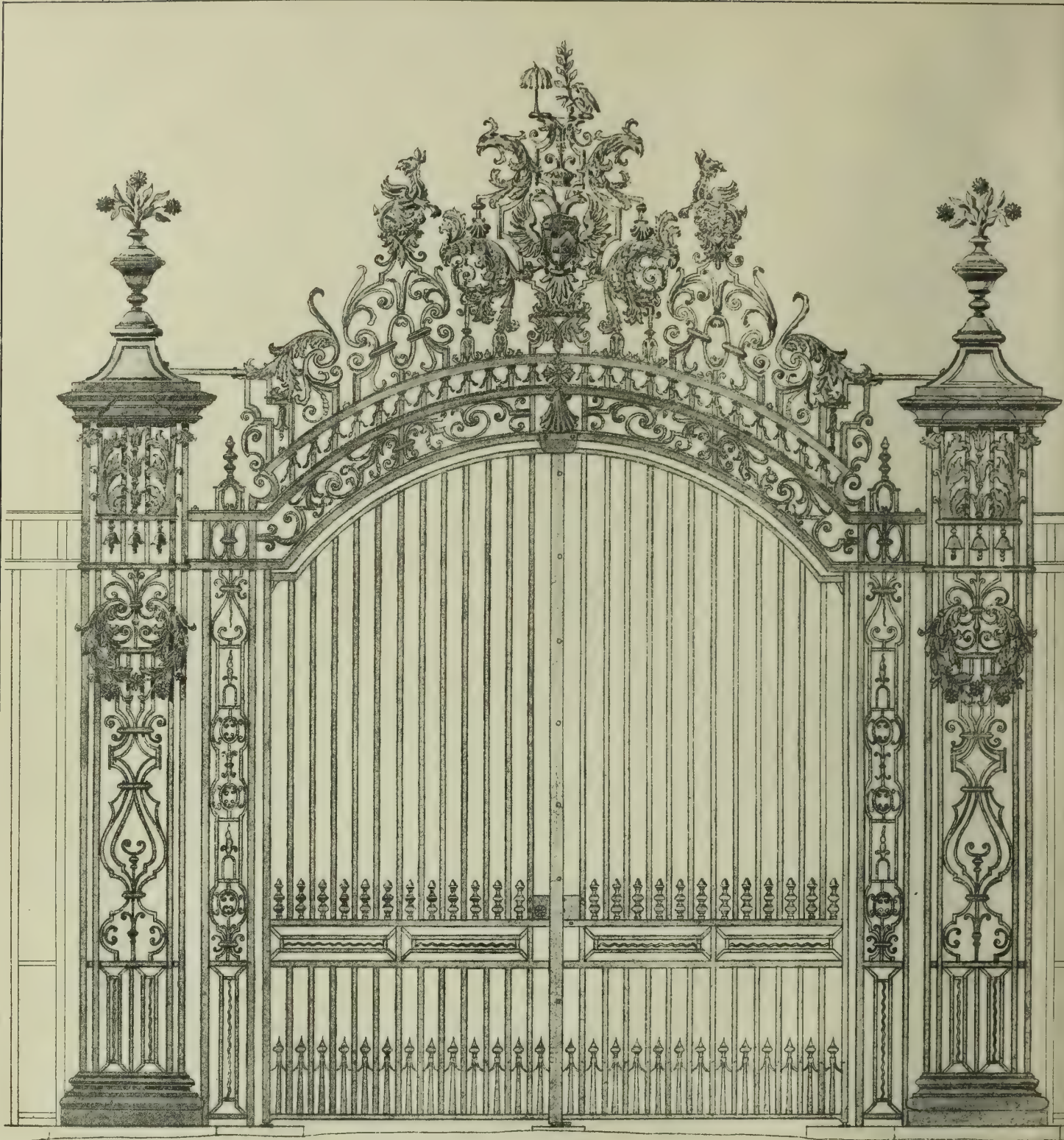

Elevation

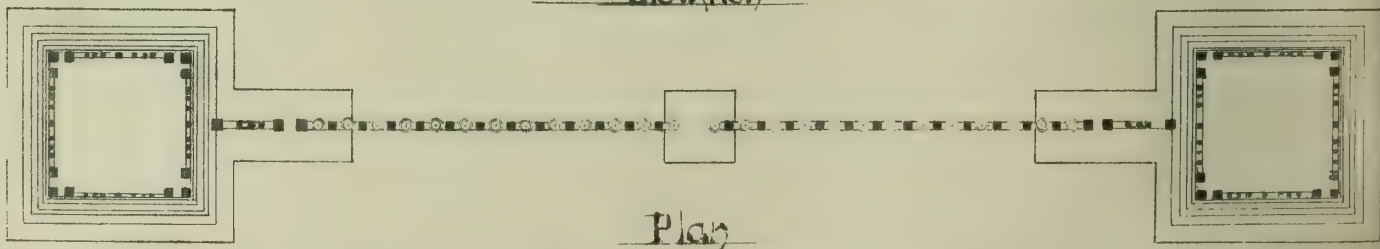

Plan

NATIONAL BRONZE MEDAL AWARDED J. J. K. PHILLIPS

*Wrought-Iron* WROUGHT-IRON GATES. NEWNHAM PADDON. LEICESTERSHIRE.

These gates were made at Colbrook Dale towards the close of the last Century: and are considered to be the finest of their kind in this Country. They were first erected at Brunwick House - Shrewsbury - but came into the possession of the Deane's Family in 1873. when they were removed and placed in their present position at Newnham Paddon - Leicestershire.

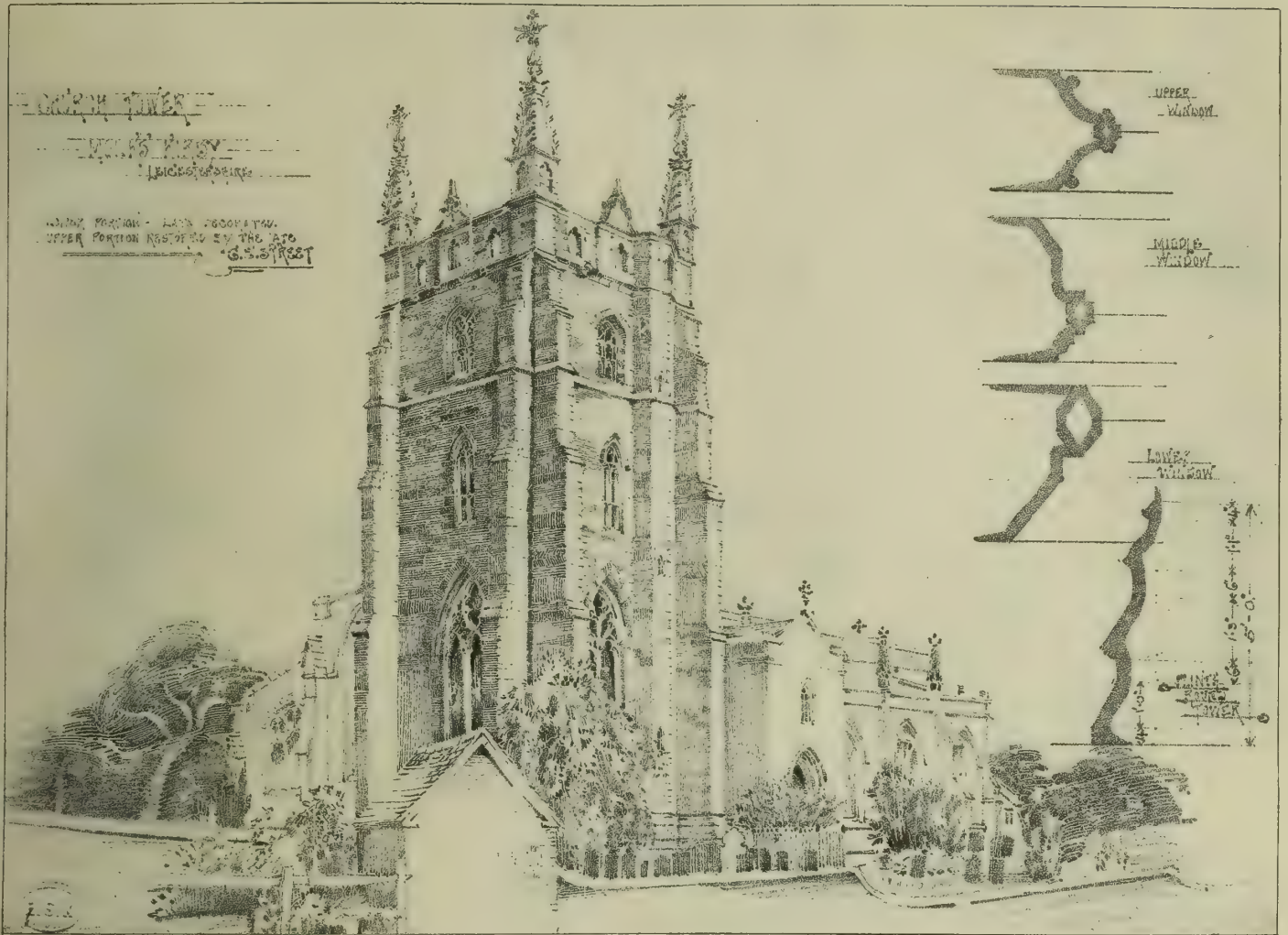

NATIONAL BRONZE MEDAL AWARDED A.E. MARTIN.

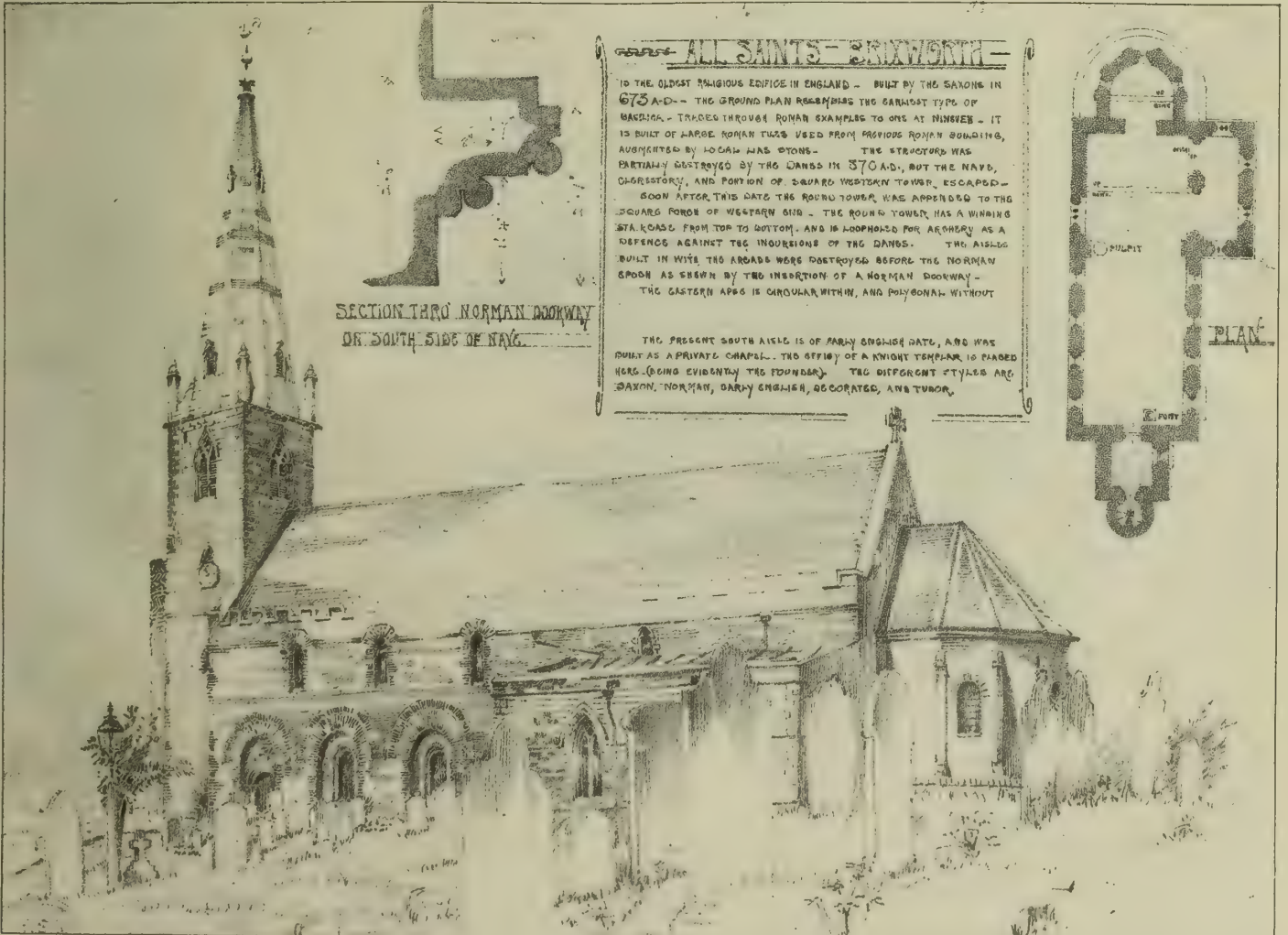









TAUNTON TOWN HALL. SELECTED DESIGN

SAMSON & COTTAM ARCHITECTS



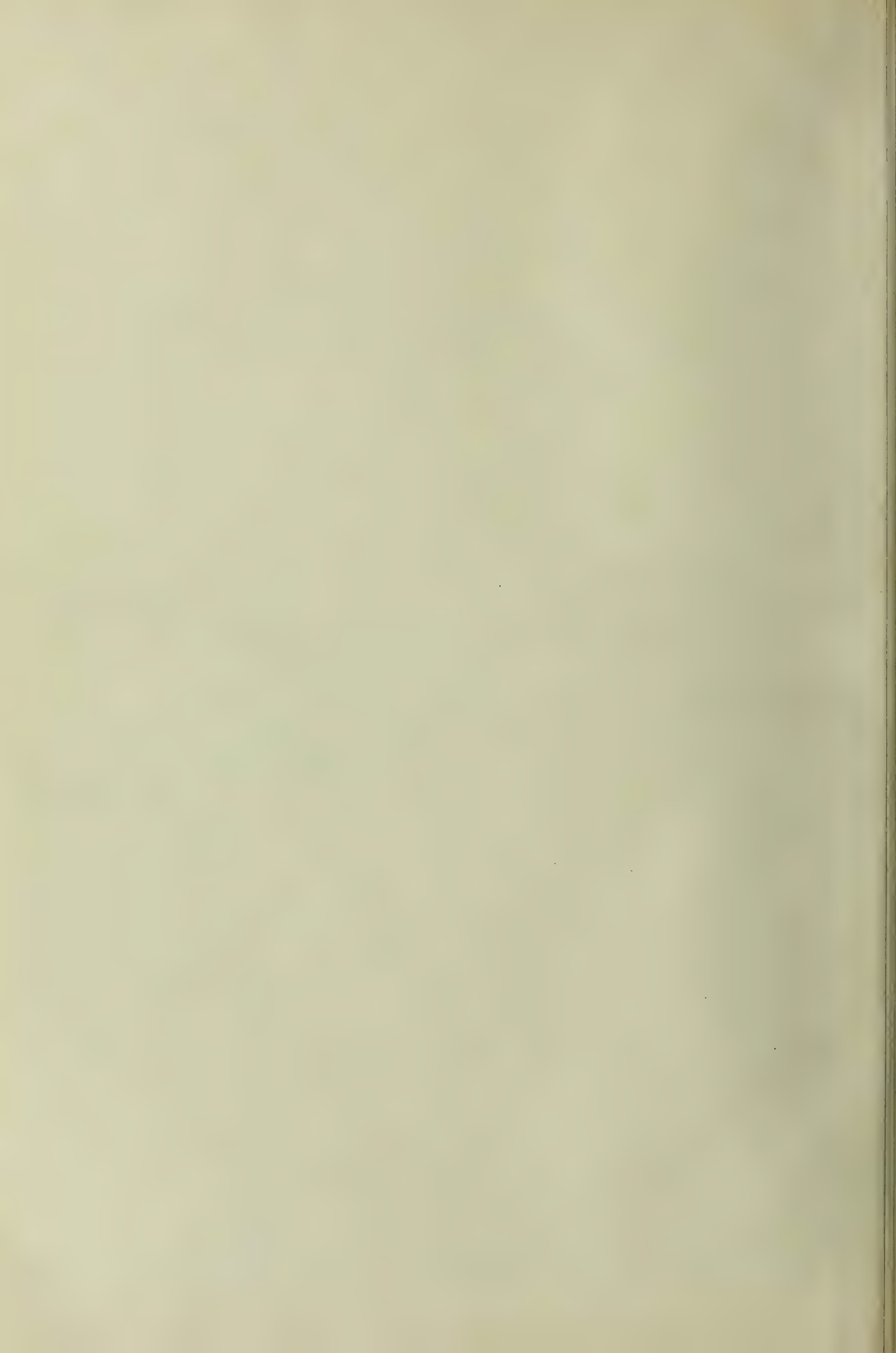

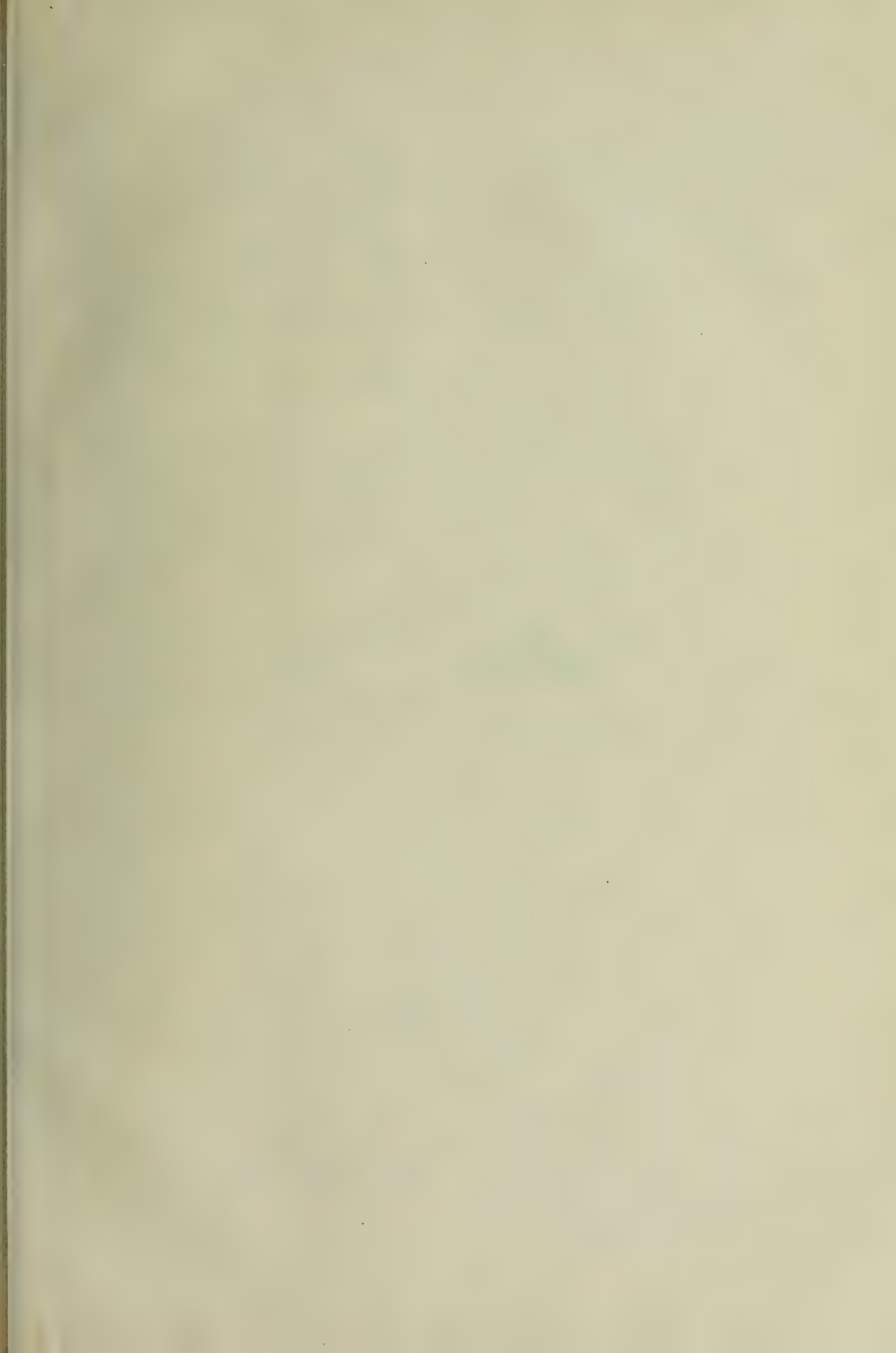

TAUNTON TOWN HALL, SELECTED DESIGN.

SAMSON & COTTAM, ARCHITECTS

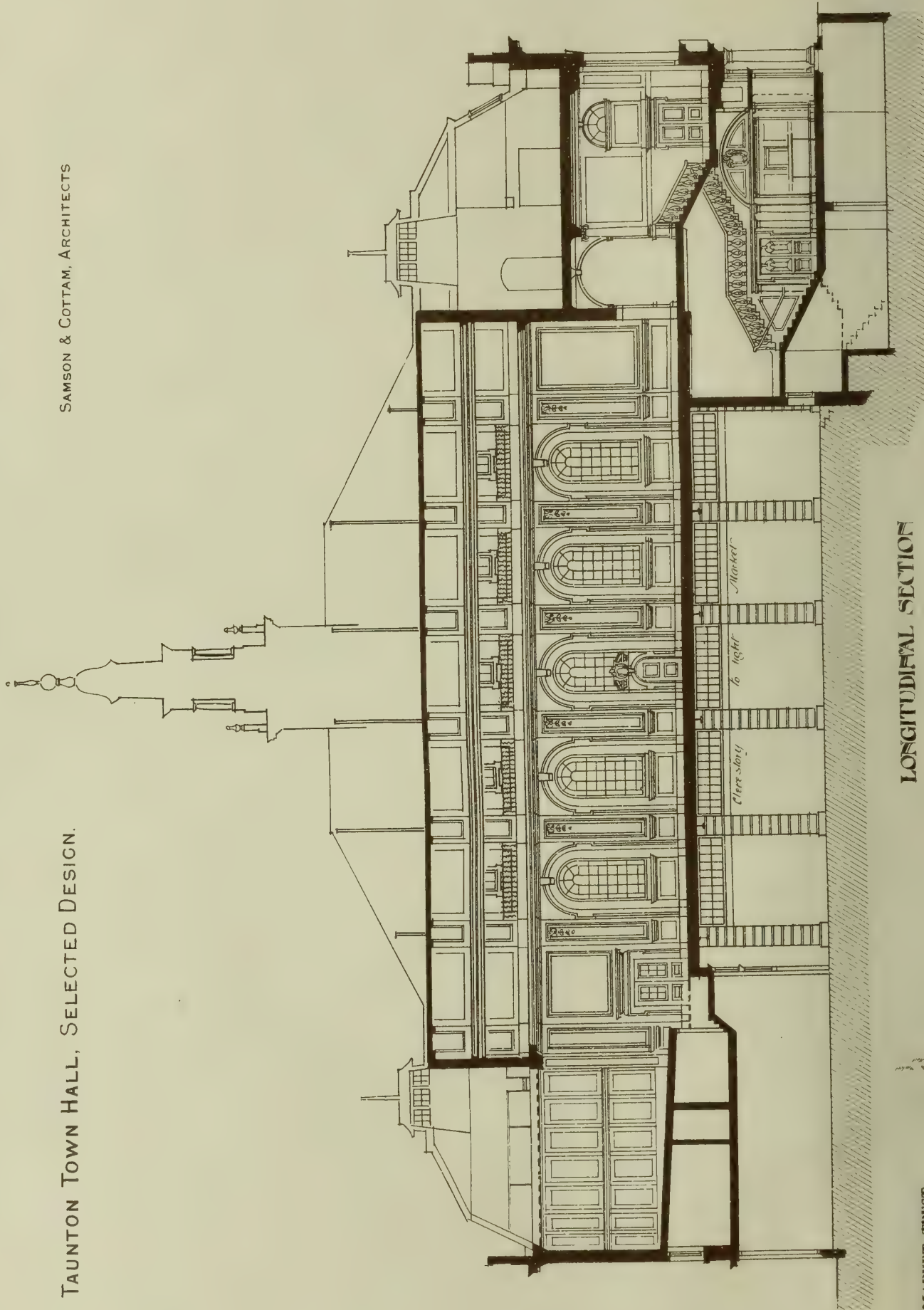

LONGITUDINAL SECTION

TAUNTON MARKET TRIST  
PROPOSED NEW TOWN HALL

1/2" = 1' 0"

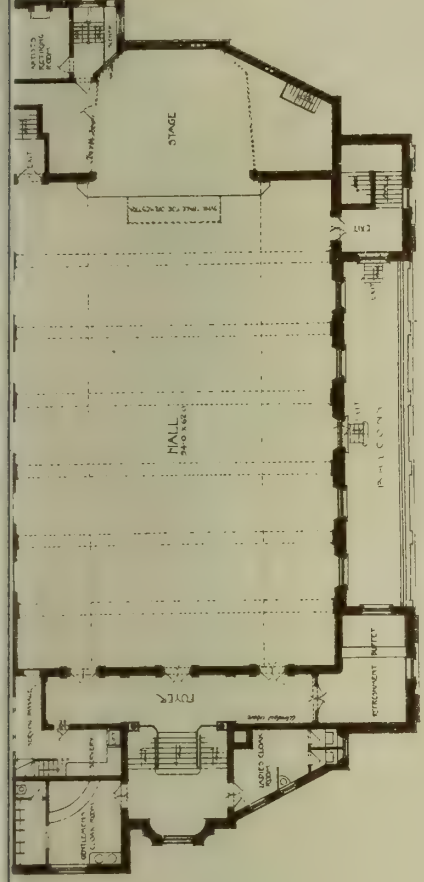

FIRST FLOOR PLAN



GROUND PLAN

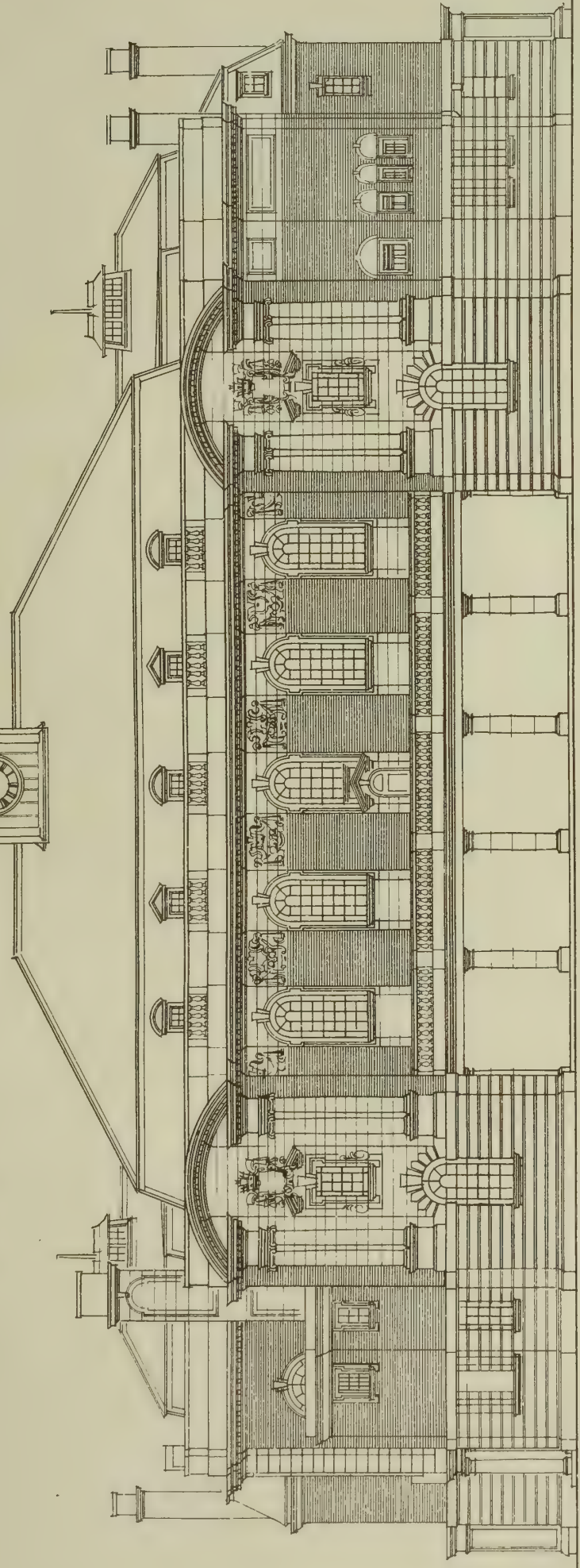

NORTH ELEVATION

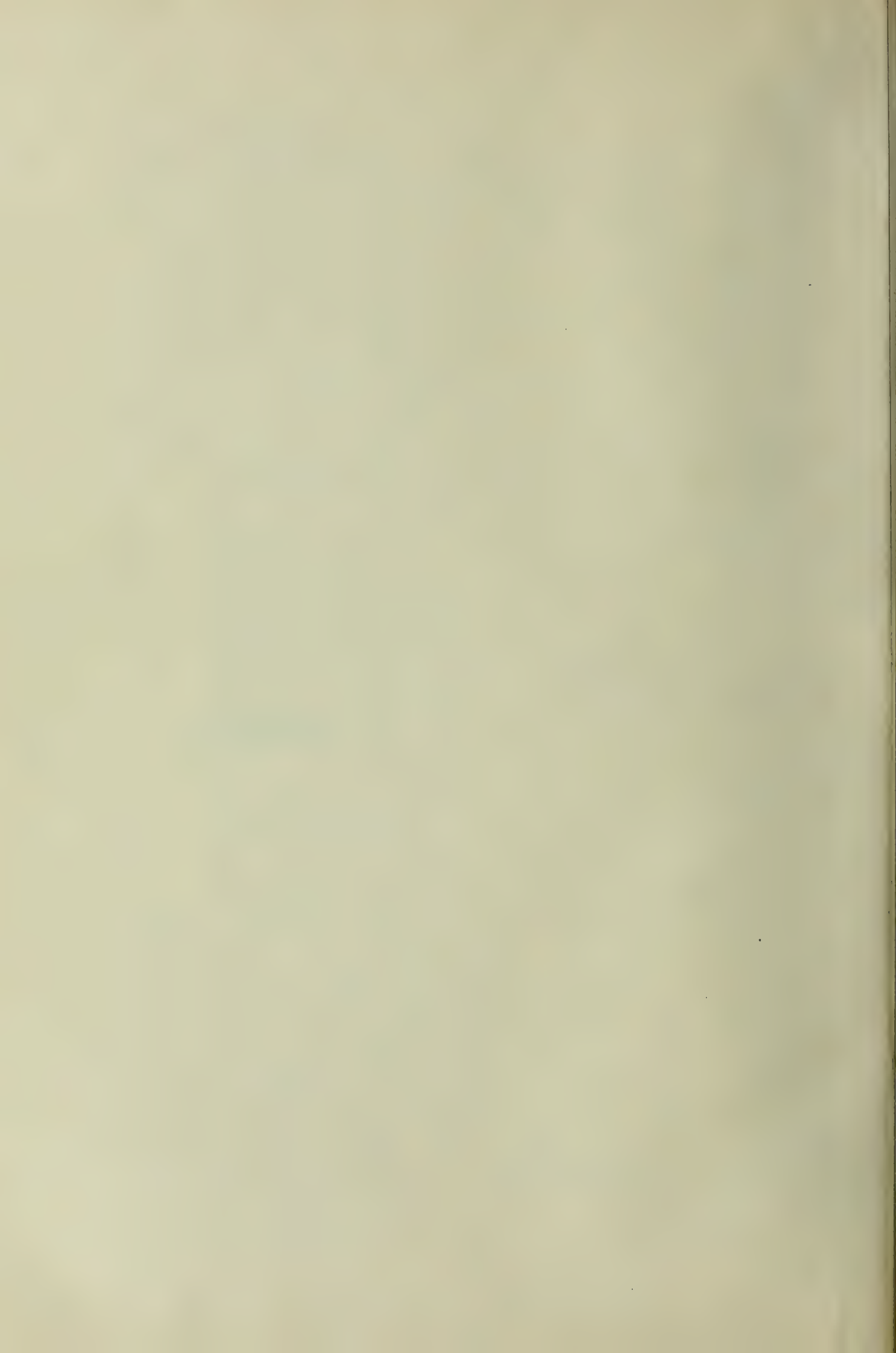



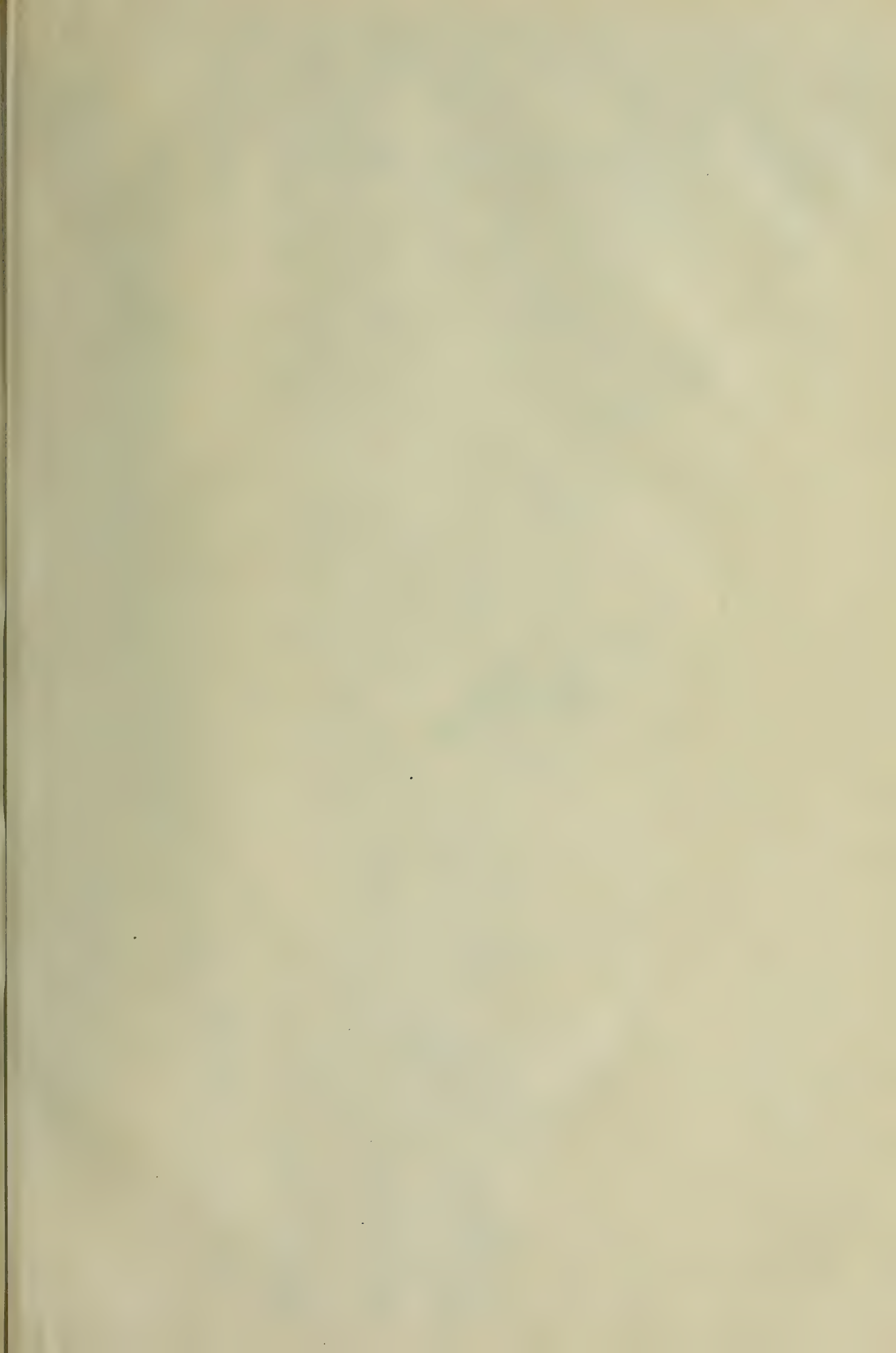

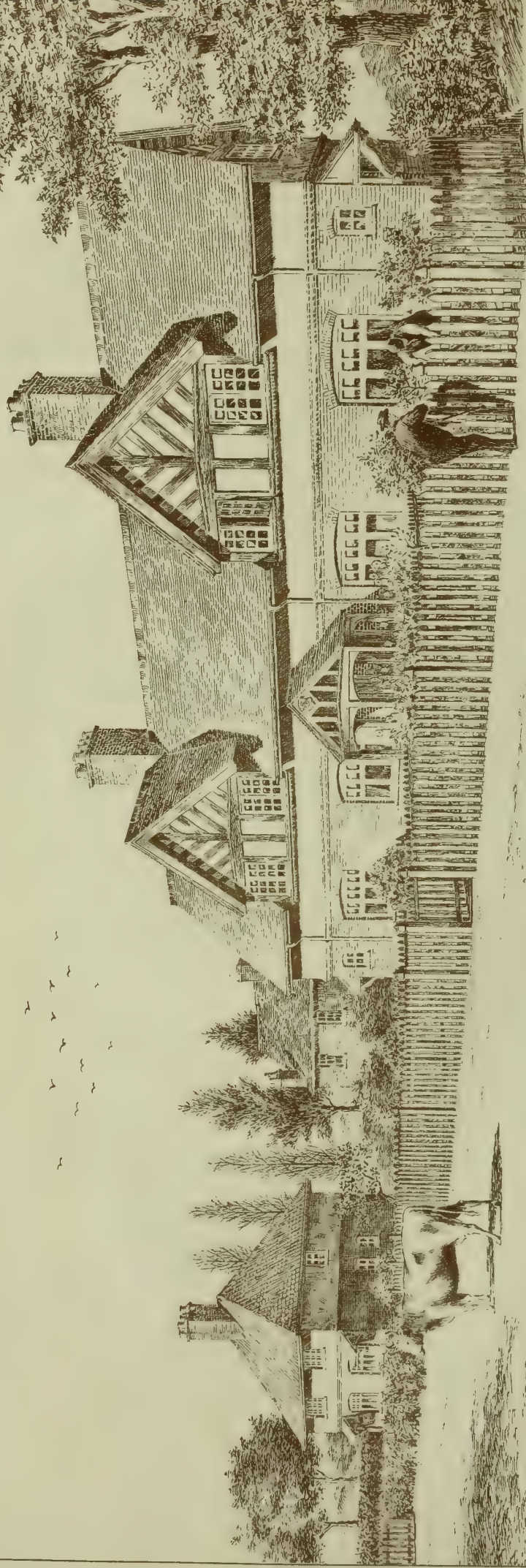
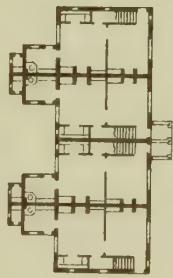

COTTAGES  
ON THE COLVIN ESTATE  
AT WALTHAM ABBEY  
F. W. ADAMS Architect

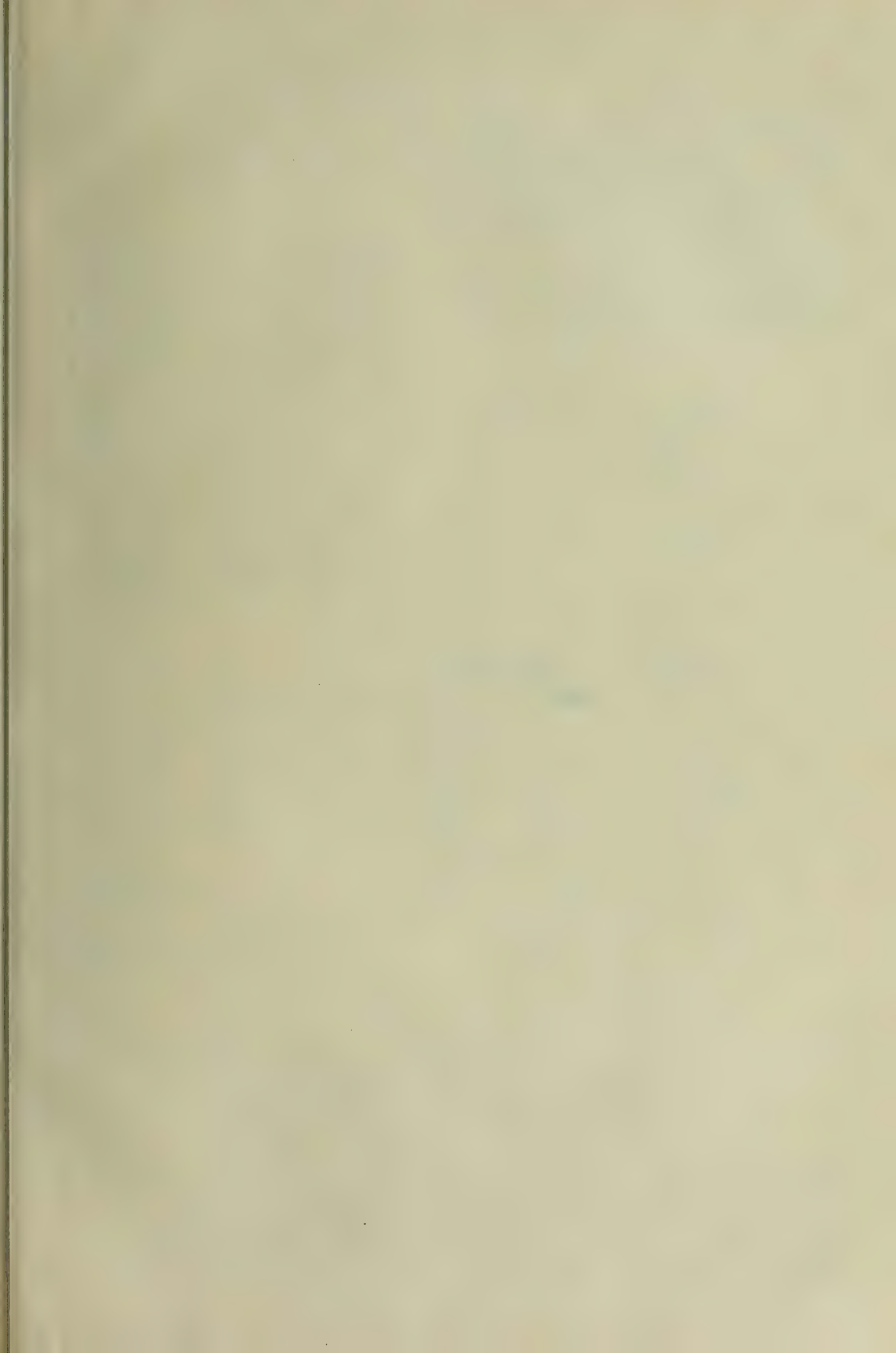

B. N. D. C. OAK FURNITURE AND CHIMNEY-PIECE FOR LIVING ROOM OF BUNGALOW. BY "CENTAUR"

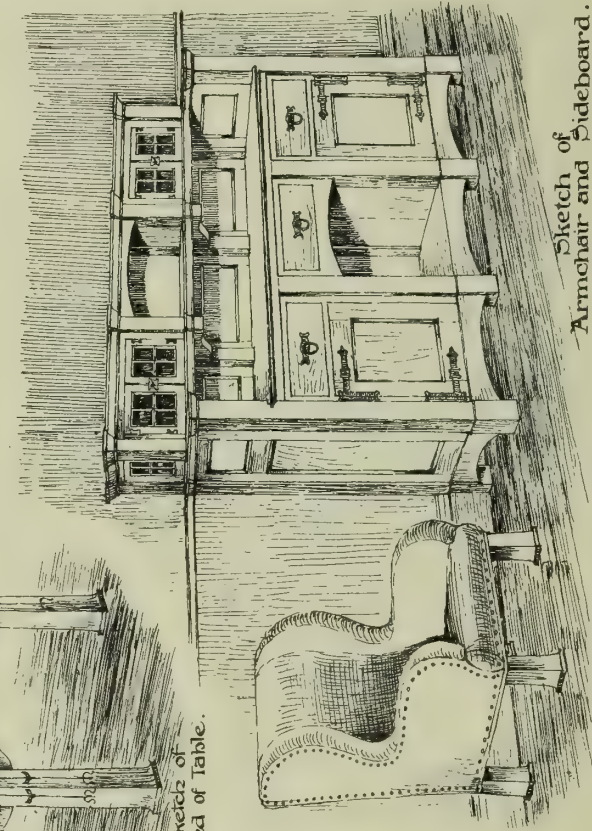
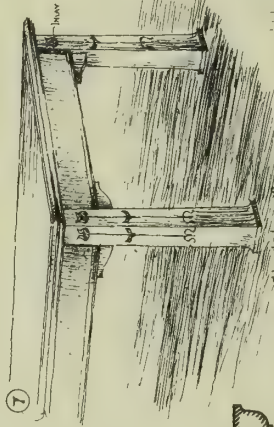
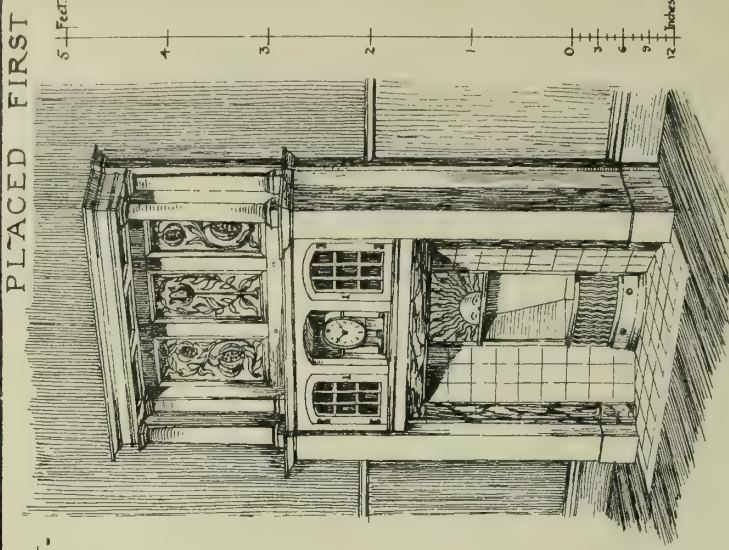

Sketch of Chimneypiece.

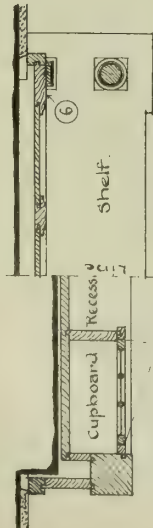

Half Plan at B.

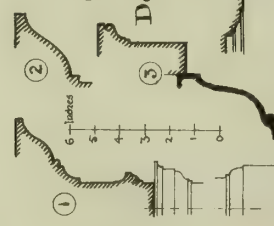

Half Plan at C.

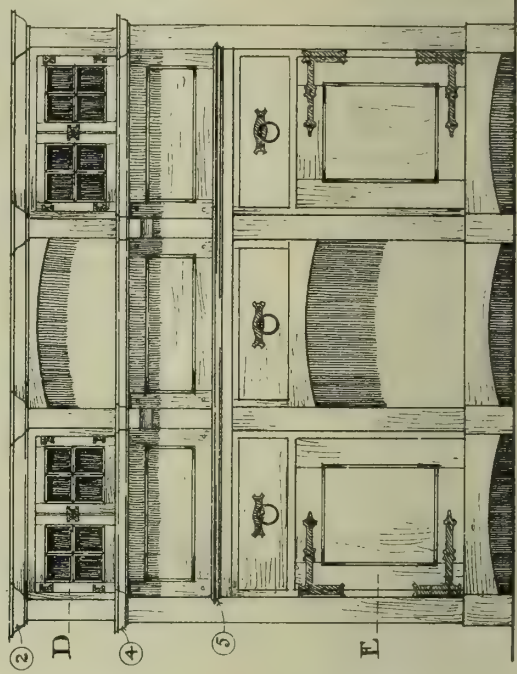
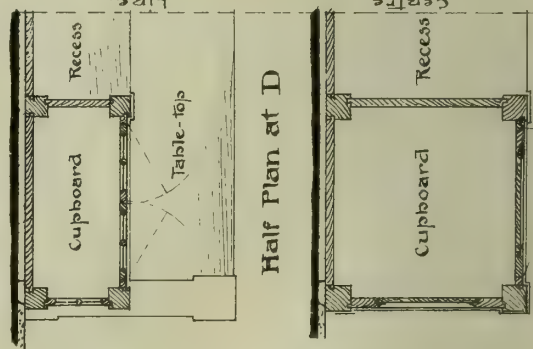
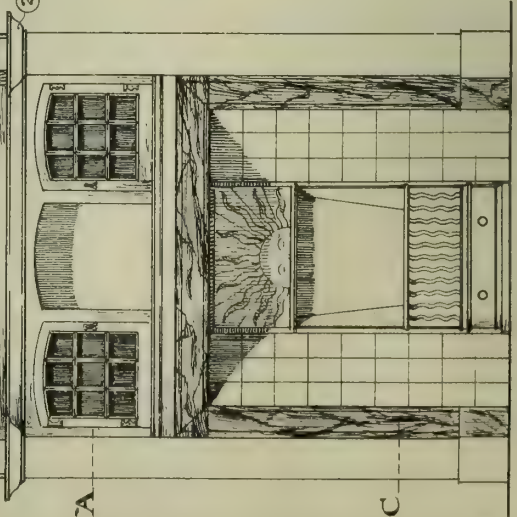
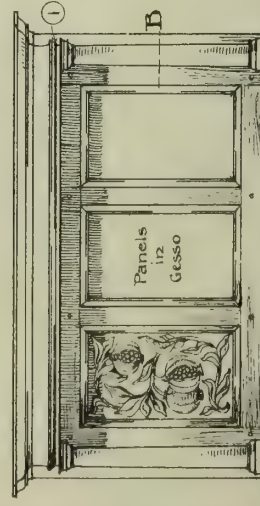

Elevation of Chimneypiece.

Section.

Half Plan at E.

Elevation of Sideboard.

Section

B. N. D. C. A. WHITE, of.  
DINING ROOM FURNITURE, DESIGNED BY PANTIE.

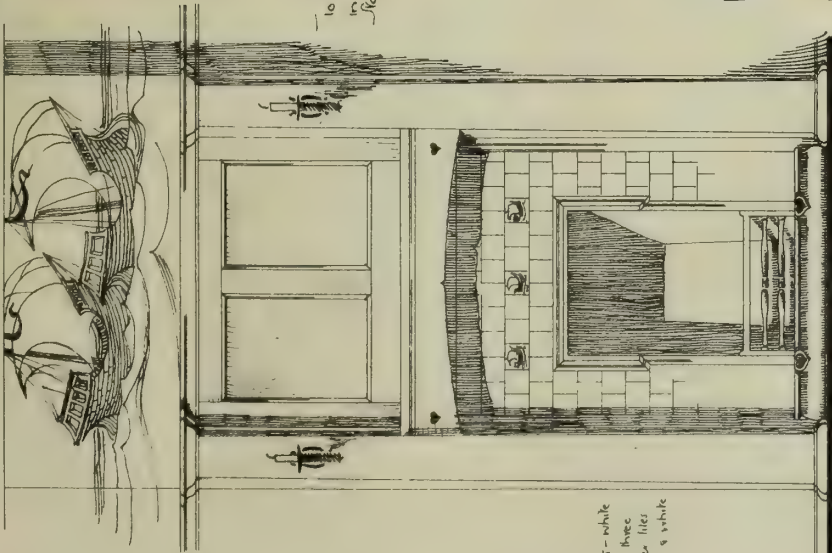

Elevation of fireplace

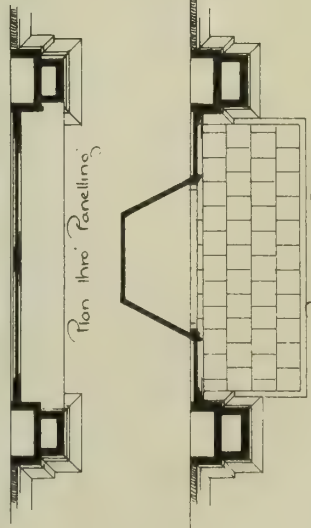

Plan thro' Panelling

Plan thro' Grate

Tiles - white  
the three  
other tiles  
blue & white

to be made  
in Oak  
Stained Green

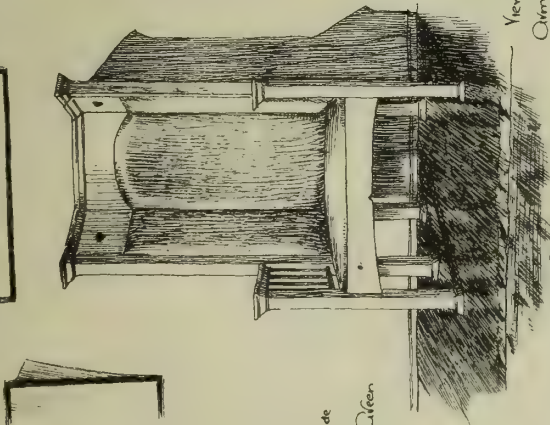

View of  
Armchair

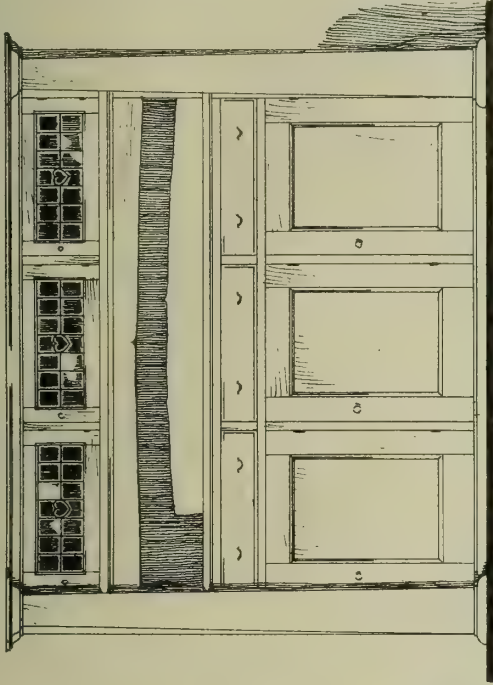

Elevation of Sideboard



Section thro'  
Sideboard

1/2" 1" 2" 3" 4" 5" 6" 7" 8" 9" 10" 11" 12"  
Foot Scale for Details  
1/2" 1" 2" 3" 4" 5" 6" 7" 8" 9" 10" 11" 12"  
Foot Scale for General Drawings



View of  
Sideboard

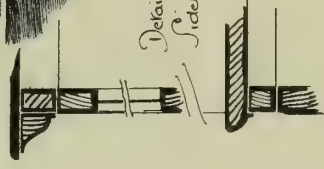

Detail of  
Table

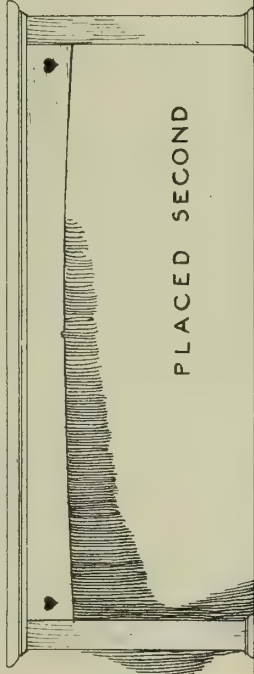

PLACED SECOND

Elevation of  
Table  
36" x 71"

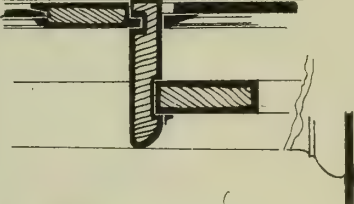

Detail of  
Fireplace

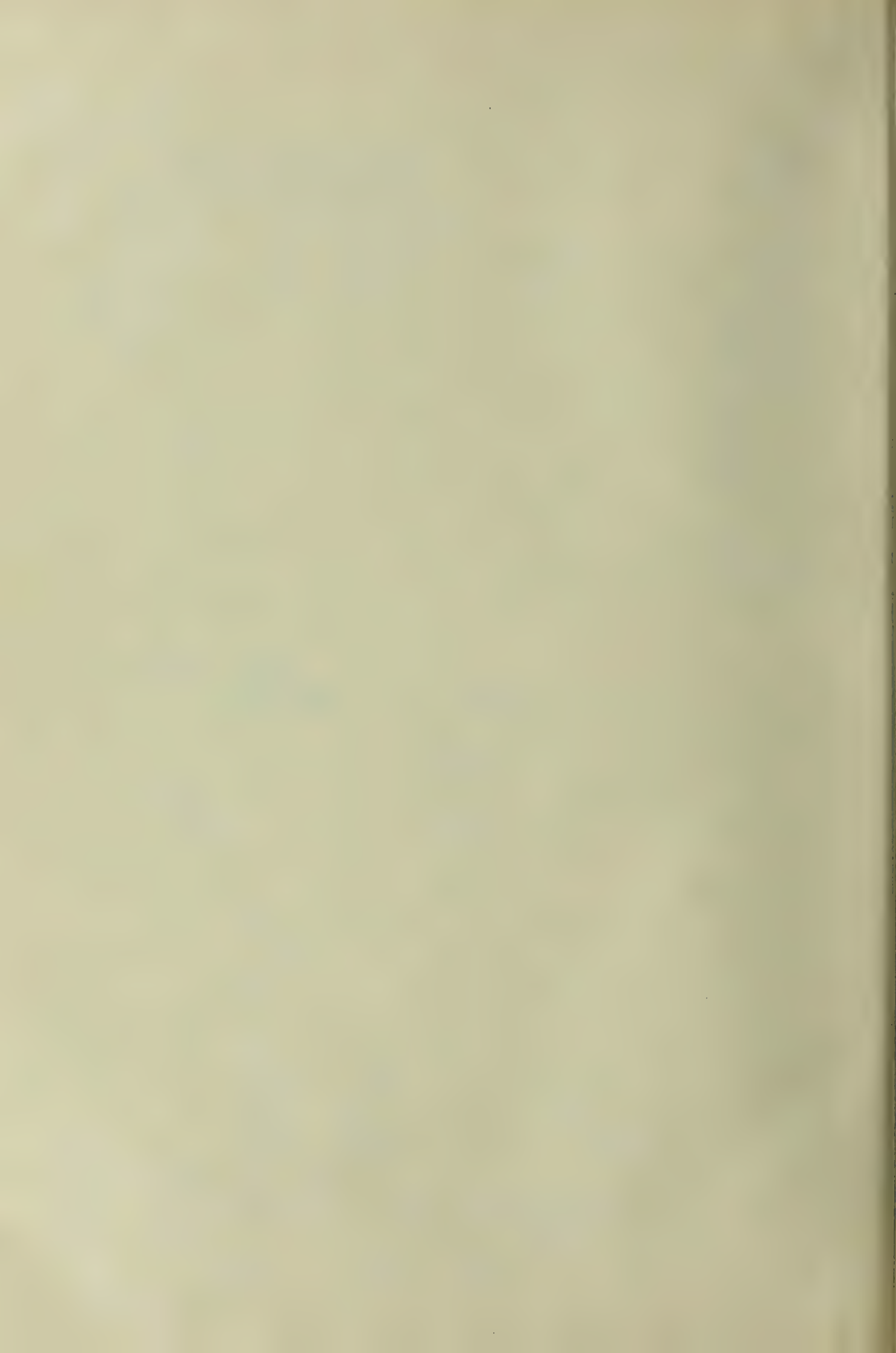

THE BUILDING PEWS, JUNE 24, 1898.

A. House  
of Medmenham  
for Kearley  
Esq. M.P.  
1897.

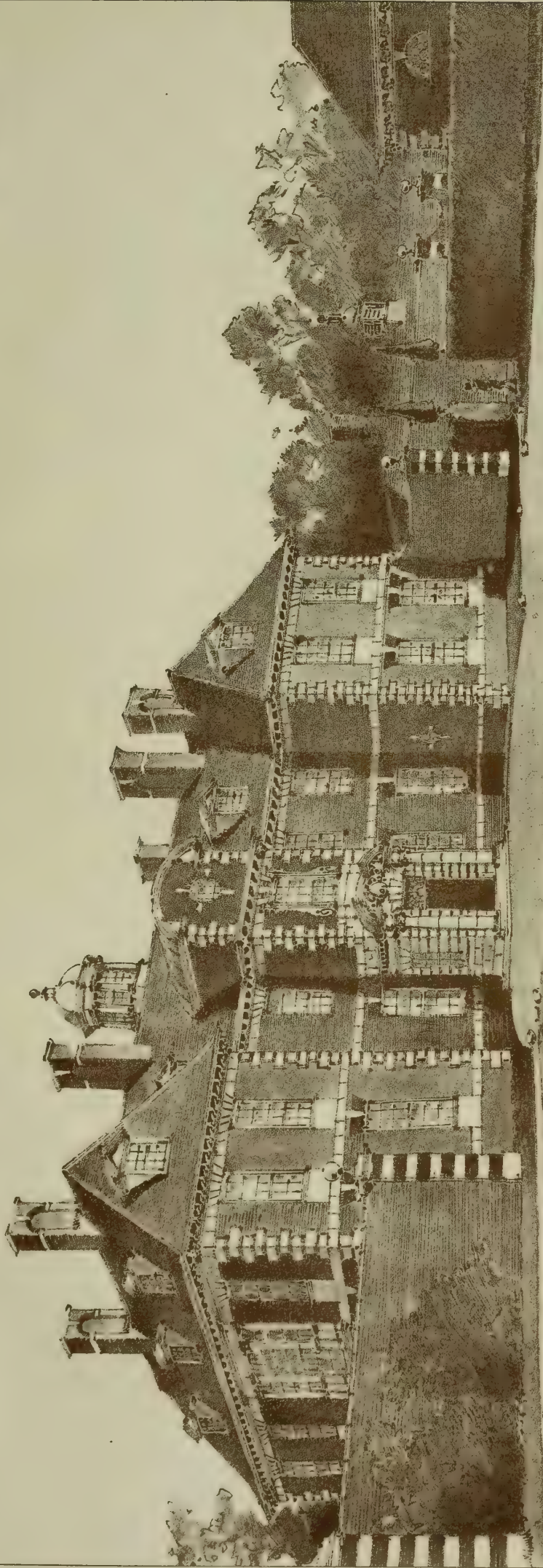

REGINALD BLOMFIELD, ARCHITECT.

PHOTO-TYPE by James Akerman, 6 Queen's Square, London, W.C.  
Reginald Blomfield

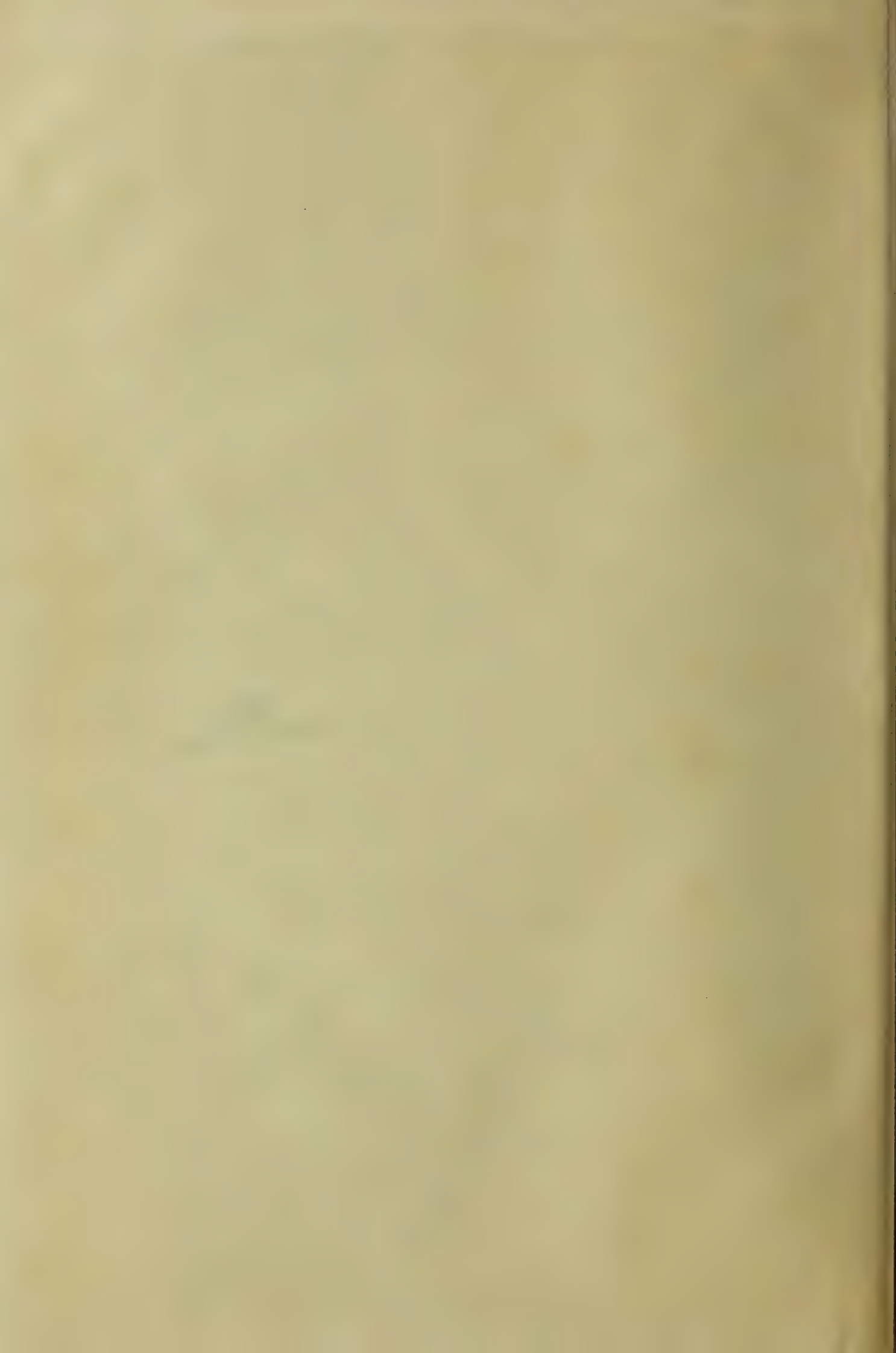



*Thos. W. S. Stammers,  
Specialist & Coachman's Cabbage,  
for W. H. Stammers Esq. & Co.*



— Ground Floor Plan.

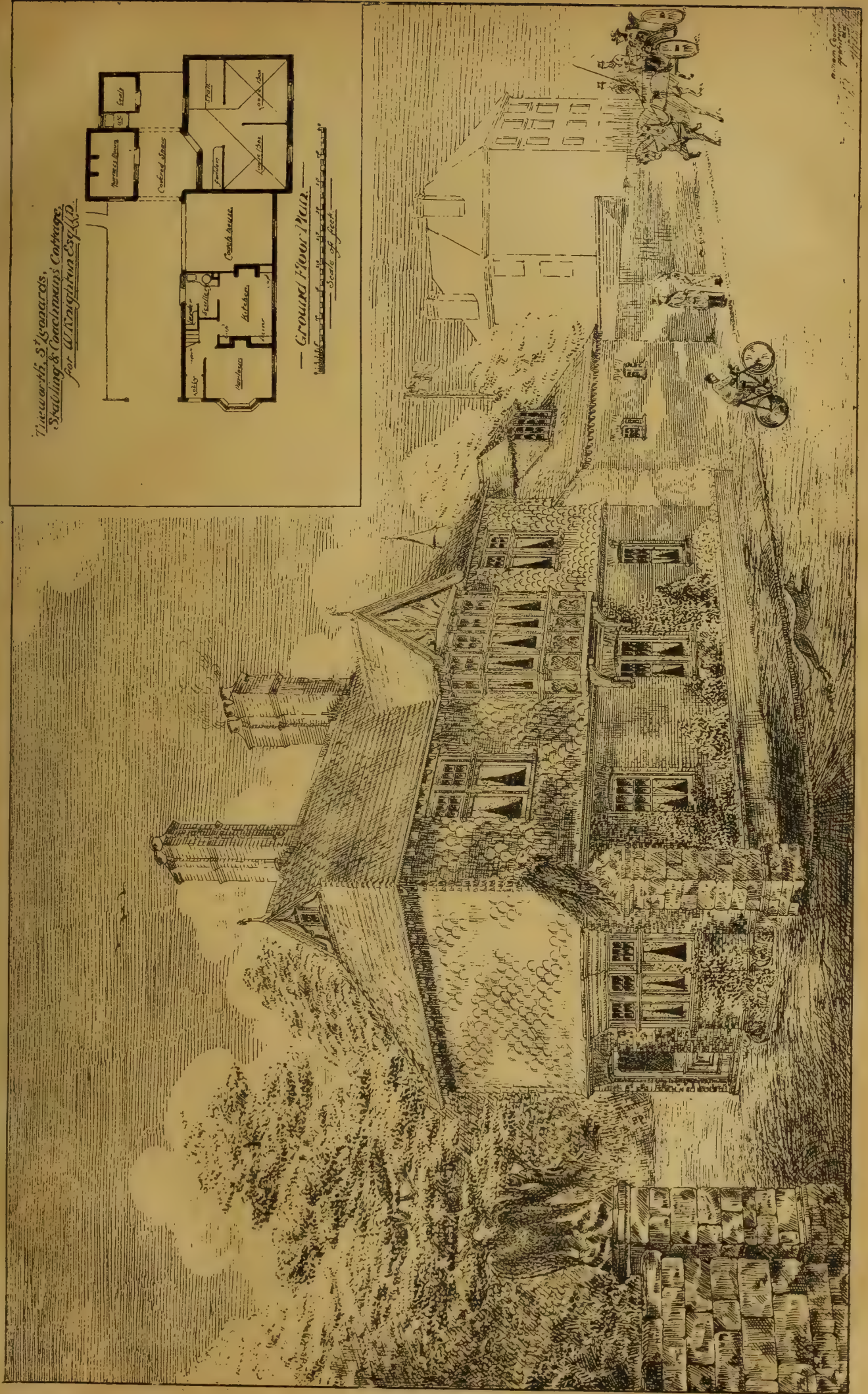

*W. H. Stammers Esq. & Co.*

## TO CORRESPONDENTS.

[We do not hold ourselves responsible for the opinions of our correspondents. All communications should be drawn up as briefly as possible, as there are many claimants upon the space allotted to correspondents.]

It is particularly requested that all drawings and all communications respecting illustrations or literary matter should be addressed to the EDITOR of the BUILDING NEWS, 332, Strand, W.C., and not to members of the staff by name. Delay is not unfrequently otherwise caused. All drawings and other communications are sent at contributors' risks, and the Editor will not undertake to pay for, or be liable for, unsought contributions.

Cheques and Post-office Orders to be made payable to THE STRAND NEWSPAPER COMPANY, LIMITED.

## TERMS OF SUBSCRIPTION.

One Pound per annum (post free) to any part of the United Kingdom; for Canada, Nova Scotia, and the United States, £1 6s. 0d. (or 6dols. 30c. gold). To France or Belgium, £1 6s. 0d. (or 33fr. 30c.). To India, £1 6s. 0d. To any of the Australian Colonies or New Zealand, to the Cape, the West Indies, or Natal, £1 6s. 0d.

## ADVERTISEMENT CHARGES.

The charge for Competition and Contract Advertisements, Public Companies, and all official advertisements is 1s. per line of Eight words, the first line counting as two, the minimum charge being 5s. for four lines.

The charge for Auctions, Land Sales, and Miscellaneous and Trade Advertisements (except Situation advertisements) is 6d. per line of Eight words (the first line counting as two), the minimum charge being 4s. 6d. for 40 words. Special terms for series of more than six insertions can be ascertained on application to the Publisher.

Front-page Advertisements 2s. per line, and Paragraph Advertisements 1s. per line. No Front-page or Paragraph Advertisement inserted for less than 5s.

Advertisements for the current week must reach the office not later than 3 p.m. on Thursday. Front-page Advertisements and alterations in serial advertisements must reach the office by Tuesday morning to secure insertion.

## SITUATIONS.

The charge for advertisements for "Situations Vacant" or "Situations Wanted" is ONE SHILLING FOR TWENTY-FOUR WORDS, and Sixpence for every eight words after. All Situation Advertisements must be prepaid.

## NOTICE.

Bound copies of Vol. LXXXIII. are now ready, and should be ordered early (price Twelve Shillings each), as only a limited number are done up. A few bound volumes of Vols. XXXIX., XL., XLI., XLVI., XLIX., LI., LII., LVIII., LIX., LXI., LXII., LXIII., LXIV., LXV., LXVI., LXVII., LXVIII., LXIX., LXX., LXXI., LXXII. may still be had, price Twelve Shillings; all the other bound volumes are out of print. Most of the back numbers of former volumes are, however, to be had singly. Subscribers requiring any back numbers to complete volume just ended should order at once, as many of them soon run out of print.

RECEIVED.—P. O. D.—S. M.—M. S. H.—F. C. J. and Co.—S. P. G.—N. M. T. U.—W. W. R.—T. A. and Son.

## "BUILDING NEWS" DESIGNING CLUB.

## NINTH LIST OF SUBJECTS.

J.—A Small Model Farm suitable for a gentleman's country residential estate of moderate proportions. The site is practically level, and the front faces the S.E. There must be a stable for four cart-horses, one box for a hack, and one for a pony; a stall-shed for six cows, and a calf-house for two, with a sick stall besides; a granary and a mixing floor; a covered yard; a set of four piggeries; a boiling-house and meal store; a cart-shed; one closed coach-house, and a harness place. An implement shed is necessary, and a dung pit. The covered yard must be light and airy, without being draughty. A little feature may be made of a clock turret, and provision must be made for a big water tank. Picturesqueness is not to be overlooked; but the design is to be simple and suitable, in keeping with farm surroundings. Plan 16ft. to the inch, elevations and sections in. to the foot. View desirable. Economy is essential.

DRAWINGS RECEIVED.—"Oak," "Centaur," "Excelsior," "Jeddah," "Gib."

## Intercommunication.

## QUESTIONS.

[1892].—**Royal Engineers.**—What foundation is there for the paragraph which has been the round of the Press to the effect that the Royal Engineers would invariably be employed in connection with military works on frontier? General Maitland, R.E., lately returned from an official tour in India in connection with the employment of R.E. officers there, and it was understood he would shortly issue a report in the matter, and that it would be influenced from a military point of view in connection with the late Frontier War. Some four years ago a committee sat in India under the presidency of Mr. Lyall, in connection with employment of R.E. officers; but on application to Messrs. Eyre and Spottiswoode I cannot find that reports of results have been issued in either case.—**ENGINEER.**

[1893].—**Drawing.**—(1) Will some reader kindly tell me whether good blue-black writing-ink does in place of Indian ink for process reproduction? (2) How is the dotted shading sometimes seen in pen-and-ink illus-

trations obtained, and how does the draughtsman denote where he wants it put in?—**L. C. M.**

[1894].—**Woodworking Machinery.**—Will any kind reader tell me the best kind of woodworking machinery suitable for shopfitter and showcase maker?—**A. G. H.** {Querist cannot do better than communicate with Messrs. F. W. Reynolds and Co., Edward-street, Blackfriars, S.E.—**Ed.**}

[1895].—**Two-Spired Churches.**—For purposes of completing a collection, can any of your readers name any church or cemetery chapel (particularly in Ireland) with a tower or spire at either end, giving at a distance the appearance of two churches adjoined?—**ARCHITECT.**

## REPLIES.

[1891].—**Parliament Street.**—On turning to "Baedeker," I find that the Treasury Buildings were erected in the reign of George I., 1717-1727, and that Parliament-street was opened for traffic in 1732.—**T. P.**

## STATUES, MEMORIALS, &amp;c.

**ST. ALBAN'S.**—Lord Aldenham having applied for a faculty for authority to complete the work of restoring the high altar screen at St. Alban's Cathedral, the Registrar of the Diocese held a court on Friday at the cathedral. As long ago as 1884 Lord Aldenham commenced restoring the screen, but in 1890, when a portion of the work had been accomplished, Lord Grimthorpe raised objections to the carrying out of certain of the proposals, and as he possessed a faculty which covered the whole building his objections were upheld. Two faculties were subsequently granted to Lord Aldenham; but he did not complete the restoration, and he now petitions for a faculty empowering him to vary the original design. At the Registrar's Court no opposition to this alteration was made, and Lord Aldenham, who has already spent about £10,000 on the screen, will in all probability receive the desired faculty within the next few days. The work now to be undertaken is the filling-in of the empty oblong space above the Communion-table with a representation of our Lord rising from the Tomb, and the placing upon the plain cross in the centre of the screen a figure of the Crucified Saviour. The work will be executed by Mr. Alfred Gilbert, R.A.

## WATER SUPPLY AND SANITARY MATTERS.

**METROPOLITAN WATER SUPPLY.**—The Royal Commission on this subject resumed its sittings on Monday. Sir A. R. Binnie, engineer to the London County Council, was further examined on the question of the partition among the outside county authorities of those portions of the water undertakings supplying within their districts but outside the County of London. In his view the counties would be well advised to take water in bulk from the proposed new authority and distribute it themselves, as in that way they would be saved any capital expenditure. But the option should be left to the outside authorities between that course and partition. After the witness had been cross-examined on behalf of the water companies, and re-examined on behalf of the London County Council, the meeting adjourned.

## CHIPS.

Lord Eustace Cecil, brother of the Prime Minister, has erected, at his sole expense, a beautiful church in the Early English style at Lytchett Minster, Dorset, where he resides. The architect is Mr. Crickmay, of Weymouth. The building has just been dedicated by the Bishop of Salisbury.

An attempt is to be made to secure "light railways" in South London. A Mr. William Murphy is promoting an application to the Light Railway Commissioners for an order authorising a light railway from Herne Hill to Farnborough, via Norwood-road, Camberwell, Lewisham, Beckenham, and Bromley. The Beckenham Urban District Council has decided to take steps to oppose the application, and the Lambeth Vestry has promised the council its support.

Archdeacon Wilson, of Rochdale, on Saturday, laid the chief corner-stone of a new school and mission church, which is being built at Castleton, at a cost of about £3,000. The buildings are Gothic in style, of red brick with stone dressings. Mr. Henry Lord, of Manchester, is the architect, and Messrs. W. A. Peters and Sons, of Rochdale, are the contractors.

The Board of Trade has issued copies of the order made by the Light Railway Commissioners, as modified and confirmed by the board, authorising the construction of a light railway in Rothwell, commencing by a junction with the East and West Yorkshire Union Railways at Robin Hood, and terminating at Royds Green Lower. The railway, which is to be known as the East and West Yorkshire Union Light Railway, is to be constructed on the usual gauge of 4ft. 8½ in., and is to be completed by Dec. 14, 1901.

## LEGAL INTELLIGENCE.

**FRANCIS MORTON AND CO., LTD., IN LIQUIDATION.**—The Receiver states that he has entered into a contract (which has received the sanction of the Court of Chancery of Lancashire) for the sale as a going concern of the works of the above company, for the sum of £70,000 (subject to payment thereout of a commission) to a responsible syndicate. The buyers have paid a deposit of £7,000 on account, and the purchase is to be completed and the balance of the purchase money paid on the 15th July next. It is one of the terms of the contract that the business shall be carried on by the Receiver in the mean time, as heretofore; but the purchasers take over all the contracts, liabilities, and engagements entered into by him in connection with the business as from the 30th June. The above-mentioned amount will be sufficient to enable the Receiver to discharge the mortgages, debentures, and other prior charges and the costs of the liquidation, and leave a balance. In addition to this, there are certain assets excluded from the above sale, which will be realised as speedily as possible. In the result it is estimated that there will be sufficient to pay to the unsecured creditors a dividend of about 6s. in the pound.

**"NO EXTRAS": A HARD CASE.**—**HORSROFT V. DAVIS.**—In this case, heard at Kent Assizes last week by Mr. Justice Wright, the plaintiff, Theodore Horscroft, builder, of Maidstone, sought to recover from the defendant, a baker, also of Maidstone, the sum of £81 14s., arising out of extras over a building contract. It appeared that plaintiff agreed to build two houses for defendant in Heathorn-street, Maidstone, for a sum of £410, and a contract was entered into to that effect. Plans of the houses were submitted to the borough surveyor, but when he saw where the houses were to be built, the site being on land which was practically a filled-up stone quarry, he would not say that the foundations, as marked on the plan submitted, would be deep enough. Plaintiff accordingly saw defendant, and discussed with him the question of foundations. The surveyor told the builder that he must take the foundations to a lower depth than the plans showed. Some conversation took place between plaintiff and defendant, and Horscroft told Davis that he reckoned the extra cost of lower foundations to defendant would be about £80. Defendant said he did not think he could find the money, and plaintiff thereupon said if he made a good thing out of the job he would make an abatement on the bill of extras. When the works were completed plaintiff found he could not make the abatement, and accordingly sent in the bill of extras for £81 14s., the payment of which defendant disputed. Counsel for defendant contended that a clause in the contract that the £410 should include all extras covered the question of the increased depth of the foundations. On the other side it was submitted that the clause referring to extras did not cover the increased cost of the foundations, and it appeared that defendant had agreed in conversation with plaintiff that something was due to him for the extra work, and made an offer of £20. The Judge decided that the claim must fail, although he admitted that it was a great hardship for the plaintiff.

**WHAT IS A STREET?**—At West London Police-court, on Monday, Mr. Lane, Q.C., heard a summons against Mr. William Henry Gibbs, a builder of West Kensington, for preparing to lay out a street at the Hamlet-gardens Estate, King-street, Hammersmith, without first obtaining the sanction of the London County Council. Residential flats were being erected on the estate, and for the defendant counsel argued that as the street—if it could be so called—was in the nature of a courtyard, and intended exclusively for the use of the tenants, it could not be considered a highway within the meaning of the Act. Mr. Chilvers, for the Council, maintained that whether the street was a private one or not, the provisions of the Act, nevertheless, applied, and he quoted the decisions of learned judges in support of his contention. Mr. Lane confessed that, after reading the decisions, they seemed to be at variance with one another. He found for the defendant, and, in dismissing the summons with five guineas costs, granted Mr. Chilvers a special case for the consideration of the Superior Court, at the same time advising that gentleman to ask the judges to accurately define the meaning of a street.

The town council of Hull have decided to widen Passage-street at an estimated cost of £27,000.

The dedication of a stained-glass window which has been erected in the church of All Saints, Bothen, as a memorial of the late Mr. Richard Pilsbury, took place on Saturday afternoon. Mr. Pilsbury was a native of Burslem, and was apprenticed to the trade of a china painter with Messrs. Alcock, of the Hill Pottery. He afterwards became connected with Messrs. Brown - Westhead and Moore, and Mintons, Limited, and at the time of his death he was art decorator at Messrs. Moore Bros., of Longton.

## PARLIAMENTARY NOTES.

**WORKING MEN'S DWELLINGS BILL.**—The second reading of this measure was moved on Wednesday by Sir Howard Vincent, who explained that its object was to empower local authorities to advance, under suitable conditions, sums of money in order to enable working men to become the possessors of their own dwellings. Not more than three-fourths of the required sum could be advanced, the working man himself paying in cash the remaining fourth, and the Bill fully safeguarded the interests of the public and those of the ratepayers. The definition of "working man" given in the Bill included clerks, warehousemen, and shop assistants, but there was an absolute condition that the total income of any recipient of an advance should not exceed £150 a year. Sir A. Hickman, who seconded the motion, observed that the measure was entirely permissive, and it was hedged round with restrictions which would be sufficient to prevent any possible abuse. The house must be intended for the residence of the man who got the advance. It must be in a sanitary condition, and the working man must himself supply one quarter of the purchase-money, while not more than £150 was to be advanced on any one house. Then there was to be no overcrowding, and the site was to be the man's own. If the Bill passed, without cost to anyone, a working man would be able to borrow at about 3½ per cent., and an advance of £150 would only cost him about 1s. 11d. a week. The great tendency of the Bill would be to encourage thrift, and to prevent overcrowding. Mr. McKenna opposed the motion, as he considered that the principle of the Bill was financially unsound. He moved an amendment, declaring that in any measure for facilitating the acquisition of dwellings for the working classes by the use of public money, the freehold ought to be vested in public bodies, and not in the individual. Mr. John Burns seconded the amendment. Sir A. Rollit and Mr. Gray supported the Bill, which was opposed by Mr. J. Samuel. Mr. T. W. Russell, on behalf of the Government, supported the motion for the second reading. The view of the Government was that the principle of the measure was good, and that after the second reading had been passed the Bill ought to go to a Select Committee. After a long discussion, the closure was carried by 174 to 88, and, on another division being taken, the amendment was negatived by 181 to 82. The Bill was then read a second time. Sir Howard Vincent then moved that the Bill should be referred to a Select Committee, but, as objection was taken, the debate stood adjourned.

## CHIPS.

The Hon. W. F. D. Smith, M.P., laid at Hendon, on Wednesday, the foundation-stone of a new infirmary which is about to be erected there by the Central London Sick Asylums District Board. The site is on the brow of a hill, and the estimated cost of the new buildings is £95,510, or, with the addition of £12,428 for the site, a total of £107,938. The infirmary will, when completed, provide accommodation for 274 patients, and the site allows ample room for any extension that may become necessary.

The Lord Mayor of Birmingham laid, on Wednesday, the foundation-stone of a new wing of the Midland Counties Hospital for Incurables at Leamington, to be erected in commemoration of the Diamond Jubilee. The extension is part of a scheme involving an outlay of £17,000.

The Church Sunday-schools at Saltash, which have been rebuilt at a cost of £800 from plans by Mr. Edmund Sedding, of Plymouth, were reopened on Friday.

Mr. John Morley, M.P. for Montrose Burghs, attended the opening, on Saturday, of a public library presented to Arbroath by Mr. David Corsar, manufacturer and leading citizen. The building, which was formerly used as the high school, occupies a central position in Hill-square. Externally as well as internally it has been radically altered to adapt it to the purposes of a library, reading-room, and picture-gallery; and, what with the addition of a new wing and entrance-porch, the placing of statues in niches on the uppermost story, and the conversion of the old playground into a terraced garden, the building is, for all practical purposes, a new possession for the town. Mr. Gavin was the architect.

The new infirmary, Wallingford, is being warmed and ventilated by means of Shorland's patent Manchester grates, the same being supplied by Messrs. E. H. Shorland and Brother, of Manchester.

The committee of the new co-operative headquarters, Leek, have accepted the tender of Mr. Thomas Grace, of Leek, for the new offices, stores, bakeries, shops, assembly and board rooms, &c., designed by Wm. Sugden and Son, F.R.I.B.A., Leek and Hanley. When fitted up and furnished, it is estimated the cost will be about £3,500. "Fair wages" clauses are incorporated by the architects in all these contracts.

## Our Office Table.

The report of the directors of the National Gallery for 1897 states that only four pictures have been purchased during the twelve months out of the Parliamentary grant in aid. They are "Christ Disputing with the Doctors," by Ludovico Mazzolino, of the Ferrarese School; a portrait of Edmund Butts, a son of Sir William Butts, physician to Henry VIII., by John Bettes; a portrait by Romney of Mrs. Mark Currie; and a portrait of Mme. Vigée Le Brun, painted by herself. The bequests and donations include Sir John Millais's "The Yeoman of the Guard," "Rabbiting," by George Morland, "Christ and the Woman of Samaria," by George Richmond, R.A., and a portrait of the late Mr. Russell Gurney, by George F. Watts, R.A. The gallery in Trafalgar-square was visited by 423,421 persons on the free days during the year, showing a daily average attendance on such days (206 in number) of 2,055. In addition to the above number, 32,876 persons visited the gallery on the 26 Sunday afternoons on which it was opened during 1897, showing a daily average attendance of 1,265. On students' days (Thursdays and Fridays) 39,358 persons were admitted. The Gallery of British Art at Millbank has been visited by 104,275 persons on the public days from August 16 to December 31, showing a daily average attendance of 1,337. On the six Sunday afternoons on which it was opened it was visited by 19,955 persons, showing a daily average attendance of 3,326. On students' days 15,795 persons were admitted between August 16 and December 31. The new edition (the 78th) of the historical and descriptive catalogue of pictures belonging to the foreign schools is in the press, and will be ready for issue shortly.

WRITING in the June issue of *A.A. Notes*, Mr. W. H. Jamieson, hon. solicitor to the Architectural Association, expresses the opinion that architects' assistants and clerks of the works are within the Workmen's Compensation Act, because the definition of the term "workman" appears to be very wide and comprehensive. It includes every person who is engaged in an employment to which this Act applies, whether by way of manual labour or otherwise, and whether his agreement is one of service, or apprenticeship, or otherwise, and is expressed or implied, is oral or in writing. In a small publication upon the Act by a barrister, he says, "the definition under the Act makes no distinction between the character of the workmen's labour, and expressly includes apprentices without any limitation. A clerk, commercial traveller, or errand-boy is open to the privileges of the Act equally with the bricklayer, coal-hewer, or engineer, and there seems no reason why the managing director of a company should not also be included." The "employers," or persons acting as "undertakers" of the employment are—says Mr. Jamieson—the parties liable.

We quoted a fortnight since a description, by Sir J. Charles Robinson, of the five large gun-metal medallions recently found at Kew, and now on view at the Art Metal Exhibition at the Royal Aquarium, by permission of the Queen. Sir J. C. Robinson has now completed his identification of the bronzes, showing in the first place, that they illustrate several distinct events and not a single occurrence, and, in the next, that the date of their production must be put somewhat later than he had at first thought to be the case—viz., shortly after 1687 rather than 1680. The earliest subject in point of date refers, he says, to the quarrel of Louis XIV. with the Pope Alexander VII., on account of the affray at the French Embassy in Rome with the Pope's Corsican guard, and which served as a pretext for the seizure of Avignon (1662); this is the subject for which the erection of a pyramid is seen in the background. No. 2 is the relieve in which are the arms of Sweden on a banner, and in which one of the personages has the Danish Order of the Elephant; this illustrates the overruling by Louis of the Elector of Brandenburg and the King of Denmark, in favour of his ally the King of Sweden, at the Peace of Nimeguen (1679). No. 3 apparently represents the submission of the Republic of Genoa, when the Doge and four of the leading Senators were sent as supplicants to Versailles (1685). Nos. 4 and 5 have reference to the further quarrel with Rome, touching the territorial pretensions of the French

Embassy, and are episodes of the same event (1687). Succinct accounts of all these transactions will be found in Voltaire's "Siècle de Louis Quatorze."

At the meeting held in Lincoln to discuss the question of erecting a statue to the memory of the late Lord Tennyson, Alderman Page quoted words from a letter written to him as Mayor of Lincoln at the time of the opening of the School of Art. Mr. Ruskin wrote: "I have always held, and am prepared against all comers to maintain, that the Cathedral of Lincoln is out-and-out the most precious piece of architecture in the British Islands, and, roughly speaking, worth any two other cathedrals we have got; secondly, that the town of Lincoln is a lovely old English town, and I hope the Mayor and Common Councilmen won't let any of it (not so much as a house corner) be pulled down to build an institution, or a market, or a penitentiary, or a gunpowder and dynamite mill, or a college, or a gaol, or a barracks, or any other modern luxury. And, thirdly, it might possibly make the students of the art classes look up a good many things that they would be the better for knowing if the Town Council were to offer a prize for a design to be painted or frescoed in the Town Hall of the most pathetic and significant scene in all British history—the first real union of Scotland and England, in the funeral procession of Bishop Hugh, when the King of England (John), bare-foot, bore the coffin with three archbishops, and the King of Scotland followed weeping."

The operations at Greyfriars Churchyard, Edinburgh, promise, says the *Scotsman*, to bring about an improvement in the locality. The old wall which bounded the churchyard at Candlemaker-row was so far off the plumb that at any moment it might have toppled over into the street, bringing along with it half a score of monuments, the Martyrs' among the rest. Something of an ornamental character will be given to the new wall, which will be divided by intervening piers into nine sections, rising by a regular succession of steps from the lower to the higher level of Candlemaker-row, and the whole will be surmounted by a 3ft. iron railing. Each pier will be finished with an ornamental cope, and just under the cope will be a cartouche panel for the reception of the name of a distinguished man buried in the churchyard. Mr. Morham, the city architect, who has designed the entire scheme, has asked Mr. J. G. Ferguson, the city recorder, to suggest, from a list furnished to him, the nine names whose memory may in this manner be perpetuated. An arched gateway, giving access to the broad flight of stairs at the bottom of Candlemaker-row, likewise enters into the scheme. The level of the ground will be slightly raised on the inside, one effect of this being that the Martyrs' Monument, which formerly stood on ground considerably below the level of the gravel side-walk, will now be seen, and its inscriptions read, to much greater advantage.

"THE Development of the Tomb in Egypt" was the subject of a lecture given by Professor Flinders Petrie at the Royal Institution on Friday night. The earliest tombs belonged, he showed, to a time when the mummy theory was not in force. The principal age of development was from about 4,000 B.C. to 2,500 B.C., after which date no new ideas were introduced. By numerous lantern-slides the lecturer illustrated the development of the above-ground portion of the tomb from a mere mound, with a niche out of which the soul might come, to a complex structure with numerous chambers and courts. He pointed out how the form and plan were influenced, now by the desire of the family to have the statue representing the deceased in full view, now by their anxiety to have it preserved from any disfigurement by having it entirely walled up, and explained how the sculptures and decorations were for the delectation of the soul. Next he described a series of tombs with sloping brickwork passages leading down to the chamber containing the coffin, and showed how, on account of engineering difficulties, the passage itself became a high vaulted chamber. The earliest pyramid started from such a type. Successive coats of masonry were added above the tombs, so as to leave the outline stepped, and finally it occurred to the builders to put on an external smooth slope. All pyramids, however, were not built in this gradual way, later ones being started *de novo* and carried out in single structures. In later times—about 600 B.C.—the tomb was merely a

well-shaft with a chamber opening off it at the bottom to contain the body, and ultimately it became a simple shallow grave into which the body was put in the clothes worn in life.

The Metropolitan Asylums Board further considered, on Saturday, a letter from the Local Government Board, dated 25th April, stating that the report of the Special Committee referring to the Brook Hospital expenditure "does not contain specific replies to the several questions asked in their letter of the 22nd October, 1897"; that the committee did not employ a competent surveyor as suggested by them, and as ordered by the managers; and that they "are still of opinion that the course suggested by them should be adopted, and will be glad to receive the information asked for in regard to each of the points referred to in their letter." An amendment "that the Local Government Board be asked to institute an inquiry into the gross extravagance of the Hospital Committee" was moved by Mr. Purchase, who said the Brook Hospital had cost £70,000 over the architect's estimate, and £38,000 worth of work had been done by the architect without consulting with the Asylums Board. Not only had the architect acted in the manner described, but, through delays for which he was responsible, the board had had to pay considerably over £2,000. The amendment was withdrawn, and on the motion of the Rev. G. W. Pope, it was agreed to reply to the Local Government Board that the board would render every possible assistance to the Government Department if they would undertake the inquiry themselves.

The proposal to establish a builders' exchange on Tyneside has been successful, and an institution under the style and title of the Newcastle, Gateshead, and District Building Trades Exchange, is being carried on by a limited liability company. The list of subscribers is an influential one, and the executive appears to be representative of all the branches of the building trade. Rooms have been secured at 62, Grainger-street, and on Monday morning last, these were formally opened. Parts of the premises will be set apart as sample rooms, to enable merchants and others to exhibit their goods. The company has been registered with a capital of £10,000 in £1 shares; but it is only proposed to issue 500 shares, as that number will be sufficient in the mean time to provide working capital. Nearly 350 of these shares have already been taken up, and the membership is over eighty.

At the Royal Institution on Saturday Dr. Caton gave the first of two lectures on "The Temples and Ritual of Asclepius at Epidaurus and Athens." The author described and showed by means of numerous lantern-slides the great sanctuary of Asclepius at Epidaurus, both in its present state and as conjecturally restored. The vast extent of the precinct was pointed out, and the beauty of the temples of Asclepius, Artemis, and Aphrodite, together with the pediment groups, acroteria, and other sculptured remains recovered which belong to the best periods of Greek art. The circular edifice known as the Tholos was described, and the difficult question as to its purpose discussed. The ward for the sick was shown in its present ruined state, and also as it probably existed in ancient times. The hostels, gymnasia, propylæa, grove, altars, baths, home for the dying, maternity building, library, and stadium were referred to, and the magnificent theatre—the finest in existence—was described. Dr. Caton afterwards gave an account of the Asclepion at Athens, a smaller and later institution, consisting of temples, Abaton, sacred well, and grove.

The Société Centrale d'Architecture de Belgique is organising an excursion from August 13th to 21st, to Champagne and Bourgogne (France), visiting Rheims, Châlons, Troyes, Langres, Dijon, Avallon, Vezelay, Auxerre, and Fontainebleau. The cost of the excursion will be about 250 francs, to include second-class travelling from Brussels, hotel accommodation, meals, carriages, and admission to monuments.

ANOTHER of the estates of the Liberator Building Society has just been disposed of by Messrs. Douglas Young and Co., the well-known auctioneers, of 51, Coleman-street, E.C. The final portion of the West Worthing Estate, comprising some 45 plots of freehold building land and six attractive freehold villas, were submitted to auction by Mr. Douglas Young on the estate on Friday last, when the whole of the land and three of the residences were disposed of for a sum-

total of £8,332. Messrs. Douglas Young and Co. have recently sold the Liberator Building Estate at Norbury, comprising 59 acres, at the sum of £17,000. This disposes of four out of the five estates offered by this firm in the sale which aroused so much public interest in July last.

#### MEETINGS FOR THE ENSUING WEEK.

**SATURDAY (JUNE 18).**—London Architectural Association. Visit to Paddockwood, Sussex, the residence of Sir Weetman Pearson, Bart. Train from London Bridge Station (L.B. and S.C.) to Three Bridges 2.25 p.m.

Northern Architectural Association. Visit to Durham Cathedral and County Council Offices.

**THURSDAY.**—Society of Architects. Special Meeting to Consider and, if approved, to Confirm Amendment of Article 11A of Association, St. James's Hall, Piccadilly. 8 p.m.

#### THE ARCHITECTURAL ASSOCIATION.

JUNE 18th, SUMMER VISIT to Paddockhurst, Sussex. Train leaves London Bridge (L.B. and S.C.R.) 2.25 p.m. P.O. for 3s. 6d. to be sent to Mr. Francis Hooper, 12, Norfolk street, Strand, before WEDNESDAY, June 15th. For further particulars see "Architectural Association Notes" for June.

J. HOWLEY SIM } Hon. Secs.  
G. B. CARVILL }

## Trade News.

### WAGES MOVEMENTS.

**ADVANCE OF WAGES TO JOINERS AND CARPENTERS.**—Advances of wages have just been conceded to joiners and carpenters in Birmingham, Catefield, Caterham, Colville, Cromer, Colwyn Bay, Liverpool, Leicester, Lincoln, Lynn, Mansfield, Whitby, Preston, Rushden, Leeds, Stockton, Carlisle, Gravesend, Maidstone, and Bournemouth. The average advances are of  $\frac{1}{4}$ d. per hour, and in the foregoing towns they apply to over 5,000 men. In Birmingham the advance does not come into force until October 1st next, but in the majority of the other towns the advances are being put into force forthwith.

**BANBURY.**—The members of the Banbury branch of the Amalgamated Society of Carpenters and Joiners have addressed a letter to the master builders in Banbury and district asking for an advance of a halfpenny an hour, on the ground that wages at Leamington, Rugby, and other towns in the Midlands are eightpence an hour, while in Banbury they are only 6 $\frac{1}{2}$ d. The men say it is twenty-one years since they had an advance of wages, and since then they have suffered a reduction of a penny an hour. They ask that the increase may commence on the 1st of July. The employers have agreed to have a conference with the men on the subject.

**LEEDS.**—The threatened strike of plumbers in Leeds has been averted. The men have been receiving 8d. per hour, and some time ago they gave notice to their employers that they required an advance of wages to the extent of a penny per hour. They also desired to have considerable alterations in the working rules, and indicated their intention to come out on strike if their demands were not complied with. Several conferences took place between the Leeds district of the National Association of Master Plumbers and representatives of the workmen, and the masters endeavoured to effect a compromise by offering 8 $\frac{1}{2}$ d. per hour. Last week the men would not accept this proposal, but at an adjourned conference, held at the Imperial Hotel, under the presidency of Mr. John Skirrow (chairman of the local branch of the Masters' Association), the men's delegates withdrew the demand for 9d., and accepted 8 $\frac{1}{2}$ d. per hour. On the question of the working hours the masters gave way, and the operatives will now work 49 $\frac{1}{2}$  hours instead of 50 hours per week, leaving off at 12 o'clock on Saturdays, whereas formerly the hour was 12.30. The working rules remain practically as they were, but a new rule has been added limiting the number of apprentices.

**LIVERPOOL.**—The house joiners have been successful in obtaining an increase of  $\frac{1}{4}$ d. per hour in their wages. This has been brought about through strong combination. The Liverpool ship joiners have not been so successful in their efforts as the foregoing, and a number of them are at present on strike; but there are now prospects of a speedy settlement of the dispute.

**MANCHESTER.**—The annual conference of the Federated Builders' Labourers' Union of Great Britain and Ireland was held on Wednesday and Thursday in last week, at the Pack Horse Hotel, Bridge-street, Manchester, Mr. John Judge, of Leeds, presiding. Consideration was given to the question of old age pensions. After some discussion, the matter was adjourned. A resolution was carried in favour of Labour representation on public bodies. On the Wednesday evening the delegates

were entertained to tea by the Lancashire organisation of Builders' Labourers. The 10th annual meeting of the Federation was held on Thursday night. Mr. Judge, who presided, spoke of the value of organisation, and urged all who were not connected with any union to at once become members. Mr. Quinn, Newcastle-on-Tyne, proposed: "That this meeting of builders' labourers pledges itself to use every effort to bring into one union every labourer who is working on a building, and who is still outside the ranks of trades-unionism." Mr. Tighe, a member of the Hull Board of Guardians, seconded; Councillor Belt (Hull) and P. Flanagan, general secretary, supported, the resolution being carried unanimously. Mr. Bennett, president of the Manchester branch, proposed, and Mr. Hood, secretary of the Building Trades Federation of Yorkshire, seconded the following resolution: "That, in the opinion of this meeting, the time has now arrived when all builders' labourers' unions should federate, and we offer to all branches a hearty invitation to join the Federated Builders' Labourers' Union of Great Britain and Ireland." Other speakers supported this resolution, which was cordially agreed to.

**WREXHAM.**—The Operative Carpenters and Joiners having applied for an advance of wages, a large number of the employers have conceded an increase of  $\frac{1}{4}$ d per hour, and so prevented a strike.

**WEAR.**—The Amalgamated Society and the Associated Society of Joiners on the Wear have claimed an advance of 3s. per week in wages. The matter will be dealt with by the Conciliatory Board.

### CHIPS.

Memorial-stones of a new Wesleyan chapel were laid at Gorleston, Yarmouth, on Monday week.

Mr. Samuel Steel, late clerk of works to the Lambeth Vestry, died on Friday at his son's residence in Yarmouth, aged 73 years.

The Bishop of Bath and Wells opened on Monday the Weymouth House Voluntary Schools at Bath, which have been erected at a cost of £8,000.

The Duchess of Rutland opened, on Wednesday week, a home for poor children from Derby and Derbyshire which has been erected at Skegness on a site purchased and given by Sir H. Bemrose, M.P. The building cost £1,170. The building is capable of accommodating 24 patients, and has been furnished gratuitously by Derby people.

The funeral of Mr. William H. Hughes, who died at the residence of his father, 4, Russell-street, Liverpool, aged 28 years, took place on Friday, at the Necropolis in that city. He was a partner in the firm of Robert Hughes and Son, building contractors, of Liverpool and Seacombe. The large number of mourners testified to the esteem in which he was held.

The foundation-stone of the new chapel of the City of London Asylum at Stone, near Dartford, is to be laid on Saturday in next week, the 18th inst., by the Lord Mayor, who will be accompanied by the Sheriffs of London.

The Rotch Scholarship for 1898 has been awarded to Mr. L. C. Newhall, of Malden, Mass., a draughtsman in the office of Mr. Arthur H. Bowditch, of Boston. Mr. Newhall is the fifteenth holder of the oldest of the great American travelling scholarships in architecture.

The memorial chapel which has been erected at Llanelwini to the Rev. John Elias, the great preacher with the Welsh Calvinistic Methodists, was opened on Saturday. The building was erected from the designs of Mr. Roberts, Portmadoc; Messrs. Williams, Upper Bangor, being the contractors. The cost is above £5,000.

The corner-stone of the new English Church at Lucerne, which is being erected by the Colonial and Continental Church Society, will be laid by Mr. F. R. St. John, Minister Plenipotentiary at Berne, on Tuesday morning next.

Corner-stones of the new Theatre Royal, Barnsley, were laid on Monday. Contracts to the amount of £10,000 have already been let, and a total expense of about £16,000 will be incurred in providing a theatre to accommodate 1,400 sitting, or a total of 2,000 when crowded. Mr. Walter Emden, P.S.A., London, is the architect, and the work is being carried out under the direction of Mr. H. Crawshaw, Barnsley.

The Bishop of Bath and Wells dedicated, on Monday, a new chapel, situated within the walls of the Bath Royal United Hospital. This chapel, built in the Classic style and seating about 150 people, forms part of a larger improvement scheme, carried out at a cost of about £2,000, which also includes new kitchens and scullery. Seats and fittings from the old chapel have been brought into the new, as also the old organ. The work has been carried out under the supervision and from the designs of Messrs. Brown and Gill, architects, of Bath, the contractors being local firms.

LIST OF COMPETITIONS OPEN.

East Ham—Public Offices, Library & Technical Institute, Fire-Engine Station, Public Baths, and Offices (cost about £55,000)	£105 (merged), £52 10s.	C. E. Wilson, Clerk U.D.C., Public Offices, East Ham, E.	June 24
Rotherham—Additions to Thornhill Board Schools.	No first, £15, £10	W. H. Cordridge, Clerk, School Board Offices, Rotherham	" 30
Penshurst—Three-Bedroomed Cottages (£180 limit each)	No premium; commission	J. Escombe, Secretary, Penshurst, Tonbridge	" 30
Baldon—Sewage Precipitation Scheme	No premium; commission	H. R. Huggins, U.D.C. Clerk, Baldon, Yorks	" 30
Bridlington Quay—Orphanage and Convalescent Home, St. John's-avenue (cost about £1,500)	£25, £10	George Abbott, Secretary, 222, Solly-street, Sheffield	" 30
Formby—Sewerage of a Portion of the Township	£100, £50, £25	J. H. Havelock Sutton, Surveyor, Piercefield-road, Formby	July 1
Widnes—Laying-Out Park	£36 15s., £10 10s., £5 5s.	H. S. Oppenheim, Town Clerk, Widnes	" 1
Linsdale—Sewage Disposal and Water Supply	£100, £50, £25	R. I. Platten, Clerk, Linslade, Leighton Buzzard	" 1
Warrington—Police Station, Court House, &c.	£100, £50, £25	J. Lyon Whittle, Clerk, Town Hall, Warrington	" 2
Beverly—Extension of East Riding County Council Offices.	£80 (merged), £20, £10	R. J. Bickersteth, Clerk, County Hall, Beverley	" 16
Glasgow—Exhibition Buildings (£60,000 limit)	£210 (merged), £156 10s., £105.	H. A. Hedley, Secretary, 141, Buchanan-street, Glasgow	Aug. 15
Pendlebury—Three Chapels, Offices, Lodge, Entrance Gates, and Boundary Wall, at proposed Cemetery	£50 (and 5 per cent. com.), £30, £20	Samuel Brown, Town Clerk, Town Hall, Salford	" 16
Stockholm—City Railway Stations and Junctions.	£656, £438, £219	Consulate General, 27, Great Winchester-street, E.C.	" 31
Glasgow—Sketch Models of Stone Figures for Fine Art Galleries	No premium	J. D. Marwick, Town Clerk, City Chambers, Glasgow	"

LIST OF TENDERS OPEN.

BUILDINGS.

Bridlington Quay—Two Houses, Belgrave-square	John Taylor	Samuel Dyer, Architect, Bridlington Quay	June 11
Lochfyne—Farmhouse and Steading	Committee	Neill Gillies, Architect, Lochgilphead	" 11
Armagh—Repairs of Mall Presbyterian Church	Committee	Robert Vogan, Scotch-street, Armagh	" 11
Ilsham—Two Cottages, Manor Farm	Guardians	Rendell and Symonds, Auctioneers, Newton Abbott	" 11
Cardiff—Infants' Block at Workhouse	Guardians	Edwin Seward, F.R.I.B.A., Queen's Chambers, Cardiff	" 11
Marytavy—Dwelling-house	Guardians	H. James, Marytavy	" 11
Guildford—Dining Hall, Kitchen, Laundry, &c.	Guardians	W. S. V. Cullerne, Clerk, Union Offices, Guildford	" 11
Faygate—Rebuilding Holmbush Inn	Committee	William Buck, Architect, Horsham	" 11
Brightingsea—Enlargement Wesleyan Day Schools	Committee	J. W. Start, F.S.I., Architect, Colchester	" 11
Lochton—Farmhouse	Distilleries Co.	Hope, Todd, and Kirk, 119, Princes-street, Edinburgh	" 11
Comber—Bonded Warehouse	Jos. Grey	Graeme-Watt and Tulloch, Architects, 77A, Victoria-st., Belfast	" 11
Leeds—Twelve Houses, Harehills-road	Agricultural & Horticultural Socy.	J. W. Thackray, Architect, 14, Infirmary-street, Leeds	" 11
Alnwick—Rebuilding Plough Inn	Knarborough Banking Company	Hope and Maxwell, 40, Westgate-road, Newcastle-on-Tyne	" 11
Bradford—Small Warehouse, Thornton-road	Knarborough Banking Company	C. H. Hargreaves, Architect, 19, New Corridor, Exchange, Bradford	" 11
Selby—Grand Stand, &c.	Knarborough Banking Company	R. Pearce-Brown, Hon. Secretary, Selby	" 11
Upper Lauderdale—Farm Cottage	Knarborough Banking Company	P. Deas, Duns	" 11
Ripon—Bank Premises	Knarborough Banking Company	Arthur A. Gibson, Architect, 8, Cambridge-crescent, Harrogate	" 11
Penrhwiweiber—Osborne Hotel	Knarborough Banking Company	W. N. Matthews, Ynisboeth Uchaf Farm, near Penrhwiweiber	" 11
Maryport—Additions to Co-operative Premises, Curzon-street	Knarborough Banking Company	C. Eaglesfield, Architect, Maryport	" 11
Ulverston—Sheds and Tan Pits	Knarborough Banking Company	Jas. Arden, 2, Brook-street, Ulverston	" 11
Dairsie—Alterations Craigfoodie Mains Steading	Knarborough Banking Company	David Stonor, 2, Brook-street, Ulverston	" 11
Berkhamstead—Repairs, &c., Workhouse, Infirmary, &c.	Knarborough Banking Company	Edward H. Alder, Surveyor, Shrublands-terrace, Berkhamstead	" 11
Lossiemouth—Shambles	Knarborough Banking Company	J. Hay Glennie, Clerk to Commissioners, Lossiemouth	" 11
Sheffield—Electric Power Station, Kelham Island	Knarborough Banking Company	Charles F. Wike, C.E., City Surveyor, Town Hall, Sheffield	" 11
Queenstown—Completing Custom House	Knarborough Banking Company	H. Williams, Secretary, Office of Public Works, Dublin	" 11
Workington—Enlarging Mossdale House, Harrington-road	Knarborough Banking Company	J. Eden, Bridge-street, Workington	" 11
Stockport—Greenhouses, Vernon Park	Knarborough Banking Company	J. Atkinson, Borough Surveyor, Stockport	" 11
Manningham—Stables, Picton-street	Knarborough Banking Company	C. E. Marsden, Architect, 3, John-street, Bradford	" 11
Aberdeen—School, Hanover-street	Knarborough Banking Company	Thomas Heaford, Clerk, Aberdeen	" 11
Cornel—Additions to Birdhill House	Knarborough Banking Company	E. A. Hackett, M.I.C.E., Architect, Cornhill	" 11
Keighley—House, Malsis-road	Knarborough Banking Company	Barber Hopkinson & Co., Architects, Craven Bank Chambers, Keighley	" 11
Bedford—Extending Electricity Works	Knarborough Banking Company	T. S. Potter, Town Clerk, Town Hall, Bedford	" 11
Blackburn—Acerrington-road School	Knarborough Banking Company	Cheers and Smith, Architects, 24, Richmond-terrace, Blackburn	" 11
Northallerton—Additions to Registry Office	Knarborough Banking Company	Walker Stead, M.I.C.E., County Surveyor, Northallerton	" 11
Cwmaman—Additions to Ivy Bush Inn	Knarborough Banking Company	Morgan and Elford, Architects, 34, Cannon-street, Aberdare	" 11
Wellington—Repairs to Spike Island Cottage	Knarborough Banking Company	Parker, Church-street, Wellington	" 11
Chorley—Alterations and Extensions, County Police Station	Knarborough Banking Company	Henry Littler, Architect, County Offices, Preston	" 11
Foveran—Alterations and Repairs at Manse	Knarborough Banking Company	Jenkins and Marr, Architects, 16, Bridge-street, Aberdeen	" 11
Heywood—Storeroom and Stables	Knarborough Banking Company	J. H. Baldwin, Town Clerk, Municipal Buildings, Heywood	" 11
Darlington—Base for a Bandstand, North-rd. Recreation Ground	Knarborough Banking Company	H. G. Stevenson, Town Clerk, Darlington	" 11
Southwram—Farmhouse	Knarborough Banking Company	Raymond Berry, Architect, Arcade Chambers, Chappside, Halifax	" 11
Ardnaguniog—Farmhouse	Knarborough Banking Company	William M'Elwee, Architect, Commercial Buildings, Foyle-st., Derry	" 11
Heywood—Storeroom and Stables	Knarborough Banking Company	J. H. Baldwin, Town Clerk, Harrogate	" 11
Dunston—Houses and Shop, Ravensworth-road	Knarborough Banking Company	H. Hutchinson, Crosskeys Hotel, Dunston	" 11
Workop—Two Public Houses	Knarborough Banking Company	W. Allen, Victoria-square, Workop	" 11
Wakefield—Boiler House at Asylum	Knarborough Banking Company	J. Vickers Edwards, County Surveyor, Wakefield	" 11
Macclesfield—Steam Laundry, Brough-street West	Knarborough Banking Company	J. Proctor, Solicitor, King Edward-street, Macclesfield	" 11
Highbridge—Additions, Cooper's Arms Hotel	Knarborough Banking Company	J. Spire, Architect, Glastonbury	" 11
Stoke Golding—Infants' School	Knarborough Banking Company	Blackwell and Thomson, Architects, Halford Chambers, Leicester	" 11
Elgin—Alterations at Steading of Upper Hempriggs	Knarborough Banking Company	Charles C. Doig, Architect, 147, High-street, Elgin	" 11
Tanfield Lea—Wesleyan Schools, Chapel-keeper's House, &c.	Knarborough Banking Company	D. M. Spence, Front-street, Anfield Plain	" 11
Dewsbury—Five Shops and Offices in New Bridge-street	Knarborough Banking Company	Holton and Fox, Architects, Westgate, Dewsbury	" 11
Carlforth—Slaughter House and Stables	Knarborough Banking Company	Chas. F. Thompson, Architect, The Arcade, Lancaster	" 11
Ellon—Auction Mart	Knarborough Banking Company	Walker and Duncan, 3, Golden-square, Aberdeen	" 11
Loughor—Chapel	Knarborough Banking Company	Daniel Davies, Grocer, Upper Loughor	" 11
Bridlington—Eight Dwelling-houses, Waterworks-road	Knarborough Banking Company	Samuel Dyer, Architect, Bridlington Quay	" 11
Halstead—Tramps' Ward, Workhouse	Knarborough Banking Company	R. L. Hughes, Clerk, Halstead, Essex	" 11
Kinloss—Cottages, Archiestown	Knarborough Banking Company	C. C. Doig, Architect, 147, High-street, Elgin	" 11
Grimsthorpe—Extension of Locomotive Offices	Knarborough Banking Company	James Williams, Secretary, Derby	" 11
Much Hadham, Hertford—Police Station	Knarborough Banking Company	Urban A. Smith, County Surveyor, 41, Parliament-street, S.W.	" 11
Elgin—Alterations at Farm Steading of Wester Colfield	Knarborough Banking Company	Charles C. Doig, Architect, 147, High-street, Elgin	" 11
Addingham—Alteration of Beacon House, and for Lodge and Stables	Knarborough Banking Company	Milnes and France, Architects, Bradford	" 17
Swansea—Post Office	Knarborough Banking Company	H.M. Office of Works	" 17
Moulsoford—Excavating and Foundation Works	Knarborough Banking Company	Committee of Visitors	" 17
Clapham, near Lancaster—Alterations to Church	Knarborough Banking Company	J. T. Morland, Clerk, Reading	" 17
Manchester—Extension of Ragged School & Home, Charter-st.	Knarborough Banking Company	John F. Curwen, F.R.I.B.A., Highgate, Kendal	" 17
Rugby—Additions to Workhouse Infirmary	Knarborough Banking Company	Maxwell and Duke, Architects, 41, Corporation-street, Manchester	" 18
Aberystwyth—House and Surgery, Queen's-road	Knarborough Banking Company	J. W. Pendred, Clerk, Rugby	" 18
Lancaster—Setting Back <i>Guardian</i> Office Front	Knarborough Banking Company	George Jones and Son, Architects, 17, George-street, Aberystwyth	" 18
Cerne Abbas—Bathrooms to Vagrant Wards	Knarborough Banking Company	T. C. Hughes, Town Clerk, Lancaster	" 18
Workop—Two Public Houses	Knarborough Banking Company	H. A. Huxtable, Clerk, Union Offices, Cerne Abbas	" 18
Earl's Court, S.W.—Rebuilding St. Matthias' National School	Knarborough Banking Company	W. Allen, Victoria Square, Workop	" 19
Warwick-road	Knarborough Banking Company	John Butler, F.R.I.B.A., 11, Redcliffe Gardens, S.W.	" 20
Leeds—Alterations, White Rose Inn	Knarborough Banking Company	Thos. Winn, Architect, 62, Albion-street, Leeds	" 20
Knarborough—School Buildings and Headmaster's House	Knarborough Banking Company	Wallace Gill, Solicitor, Knarborough	" 20
Flint Hill—Two Houses	Knarborough Banking Company	J. Moyle, Architect, Hobson, Burnopfield	" 20
Grays—Schools	Knarborough Banking Company	T. A. Capson, Clerk, Orsett-road, Grays	" 20
Leamington—Engine House at Pumping Station	Knarborough Banking Company	H. C. Passman, Town Clerk, Leamington	" 20
Warlingham—Foundations & Substructure of Lunatic Asylum	Knarborough Banking Company	Borough Engineer's Office, Town Hall, Croydon	" 20
Kirkstall—Alterations, Woodman Inn	Knarborough Banking Company	Thos. Winn, Architect, 62, Albion-street, Leeds	" 20
Exeter—Enlargement of Head Post Office	Knarborough Banking Company	Hon. Reginald B. Brett, Secretary, 12, Whitehall-place, S.W.	" 21
Portsea—Church of St. Stephen, Portsea (700 seats)	Knarborough Banking Company	Reginald A. Crowley, Architect, 22, High-street, Croydon	" 22
Stockport—Laundry, &c., and New Wing to Infirmary	Knarborough Banking Company	Woodhouse and Willoughby, Archts., 10, King-street, Manchester	" 22
Bury—Art Gallery and Public Gallery, Moss-lane and Silver-st.	Knarborough Banking Company	John Haslam, Town Clerk, Corporation Offices, Bury	" 22
Dublin—Additions to Children's Home, Cabra	Knarborough Banking Company	J. Morris, Clerk of Works, 21, Cabra-place, Dublin	" 23
Surrey—Isolation Block at Infirmary, East Dulwich-grove	Knarborough Banking Company	Frederick Wheeler, Architect, 6, Staple Inn, London, W.C.	" 23
New Brompton—Drapery Stores, High-street	Knarborough Banking Company	Ernest J. Hammond, Architect, 111, High-street, New Brompton	" 23
Flookburgh—Three Cottages	Knarborough Banking Company	W. R. Nash, Clerk	" 25
Derbyshire—Additions to Abbotsholm School	Knarborough Banking Company	Wm. Sugden and Son, F.R.I.B.A., Leek and Hanley	" 25
York—Electric Light Station	Knarborough Banking Company	A. Creer, City Engineer, Guildhall, York	" 25
Nelson—Refuge Destructor	Knarborough Banking Company	R. M. Prescott, Town Clerk, Town Hall, Nelson	" 25
Leeds—Dead Meat Market	Knarborough Banking Company	J. Harrison, Town Clerk, Leeds	" 25
Horton, near Epsom—Superstructure of Lunatic Asylum (for 2,000 Patients and Staff)	Knarborough Banking Company	G. T. Hine, Architect, 35, Parliament-street, S.W.	" 27

BUILDINGS—continued.

Table listing building projects and architects. Columns include project name, location, architect name, and completion date. Projects range from Knutsford Workhouse Chapel to Newstead Wesleyan Chapel.

ENGINEERING.

Table listing engineering projects and committees. Columns include project name, location, engineering firm or committee, and completion date. Projects include Bushey Heath Reservoir, Colne Valley Water Company, and various railway and industrial works.

FENCING AND WALLS.

Table listing fencing and walling projects. Columns include project name, location, contractor or committee, and completion date. Projects include Eggleston Fence, Blairgowrie Fence, and Stockport Wrought-iron Hurdles.

# THE BUILDING NEWS AND ENGINEERING JOURNAL.

VOL. LXXIV.—No. 2267.

FRIDAY, JUNE 17, 1898.

## THE REVISED SCHEDULE OF PROFESSIONAL CHARGES.

WHETHER it is wise to substitute a new schedule of professional charges, such as that published and now under discussion, for the older and partially-recognised schedule issued by the Institute of British Architects, is a question of some moment for the profession. Some members of the Institute have expressed their doubt as to whether the trifling alterations and additions made are worth the risk of publishing a new form which is sure to provoke criticism and doubt. For, as we have had to point out before, no professional agreement as to charges or custom is binding on the public. We know what the Courts have held in this question, and it is exceedingly doubtful if any new arrangement will meet with the concurrence of judges. If the charges are established on custom, it may be said that it is not worth while to amend them. On the other hand, the old schedule is by no means a model of its kind: the clauses are intermixed, and the wording in some cases is indefinite.

We refer our readers to the new or remodelled clauses published in our last issue, from which it will be seen that some of the old clauses have been improved and rendered more intelligible. Clauses I. and II., as amended on Mr. Wm. Woodward's suggestions, are certainly improved in some particulars. The transposal of the sentence relating to the clerk of works appointment from the first to the second clause is an improvement, certainly. It is better, also, that the architect's commission should exclusively be dealt with in the first clause without referring to subsidiary matters. If the reader will compare the old with the new schedule, he will find that the revised clause No. I. includes items that are now contained in other clauses of the old form. By incorporating them in one clause, all referring to what the architect's 5 per cent. includes, the schedule is much simplified; as we have also in the next clause a statement of what are not included in this commission. We are not quite sure whether the old words "executed from his designs" are not better than the substituted ones, "under his direction;" though, practically, of course, an architect's directions would imply his design in most cases. No doubt, also, the substituted words may be argued as being more just to the profession, inasmuch as the architect has often to carry out buildings that are not strictly according to his design, the latter having been altered or modified by his client, and it would be open to a litigious client to say "it was not entirely his architect's design," but his own. We agree, however, with a suggestion made, that the clause would be better if the words were, "executed from his designs or under his direction." Clauses I. and II. as amended read:—1. The usual remuneration for an architect's services, except as hereinafter mentioned, is a commission of 5 per cent. on the total cost of works executed *under his directions*. Such total cost is to be valued as though executed by a builder with new materials. This commission is for the necessary preliminary conferences and sketches, approximate estimate when required (such, for instance, as may be obtained by cubing out the contents), the necessary, general, and detailed drawings and specifications, one set of tracings, duplicate specification, general superintendence of works, and examining and passing the accounts, exclusive of measuring and making

out extras and omissions." It will be noticed this clause includes the old clauses 5, 11, 12. Clause II., as amended, runs: "This commission does not include the payment for services rendered in connection with negotiations relating to the site or premises, or in supplying drawings to ground or other landlords, or in surveying the site or premises, and taking levels, making surveys and plans of buildings to be altered, making arrangements in respect of party-walls and rights of light, or for drawings for, and correspondence with, local and other authorities, or for services consequent on the failure of builders to carry out the works, or for services in connection with litigation or arbitration, or in the measurement and valuation of extras and omissions. For such services additional charges, proportional to the trouble involved and time spent, are made. The clerk of the works should be appointed by the architect, his salary being paid by the client." This clause covers the ground now included in clauses 5, 7, and 11.

From these two clauses it will be seen that while the first states what are included in the customary commission of 5 per cent., the second distinctly states the items not embraced. The new words, "or for drawings and correspondence with local and other authorities," are desirable. It is impossible to define charges for all these services: they must be regulated by the degree of skill required or time expended. Clause III. embodies the old clauses 4 and 10, the first of which refers to works of small cost of £500, in which it is laid down that the charge should be by time, or by an ascending scale reaching 10 per cent. for works under £100 in cost. Clause 10 refers to alterations of premises, which generally involve much time and trouble. The revised clause states that in works of less cost than £1,000, and in designs for furniture and fittings, decorative painting, mosaics, sculpture, or stained glass, and in alterations, the "charge is regulated by special circumstances and conditions."

The insertion of £1,000 instead of £500 is an improvement, and is less likely to be questioned. This clause includes all works requiring special artistic skill in design and superintendence. Time and skill expended are here the chief considerations to be taken into account. A percentage on cost is a totally inappreciable method of assessing remuneration, and the words added in cases of alterations and additions to buildings include a class of work which the percentage commission is quite inadequate to pay for. Clause IV. is also important—it modifies Clause 3 of the old schedule. The new words—"but the arrangement does not apply to the reduplication of parts in one building undertaking, in which case the full commission is to be charged on the total cost"—are not very clear, and, on the whole, Clause 3 of the old form seems more definite and precise in its application. The other revised clauses, especially those of V., VI., VIII., XI., XIV., XVI., have been modified or rendered more explicit. The reference to the Office of Works custom in the old clause 6 has been omitted for the sufficient reason that the schedule was no longer in force. Clause X. substitutes the old clause 21, which refers to preparing specifications and superintending and certifying the formation of roads, fences, &c., for estates. A charge of 2 per cent. on estimate is proposed for this work, and when the roads, &c., are completed, an additional 4 per cent. On these and other revisions we shall again have to speak, and in the mean time we advise our readers to carefully peruse the revised clauses.

## DUDLEY GALLERY ART SOCIETY.

THE summer exhibition of this Society, held at the Egyptian Hall, Piccadilly, comprises a few water-colour pictures and

sketches of interest. We cannot say they are all worthy of exhibition. Many of them are the work of novices, weak in drawing or sentiment. As usual, there are a large number of seaside pieces, coast views, still life, and *genre*, and these classes may each be divided into original work and picture-making. But to proceed in the order of the catalogue. Several lady artists and amateurs contribute. The flower-painting of Mima Nixon is admirably restrained and natural. Her "Chrysanthemums" (2) is certainly one of the best works of the kind; the white, yellow, and deep red flowers are arranged loosely and naturally in a jug of dark bluish-green glazed ware, and the dark background is helpful. Near it Louise Fumage (8) has a study of rhododendron blossom, white and violet; the flowers are loosely thrown on a table, a basket standing behind—carefully painted, and without formality. Miss Margaret Bernard has several works of breadth and power. Her view from "Wapping, Looking Down the River" (6), with its craft and rippled surface reflecting the light, is a clever sketch. Few of her works are more pleasing than the view "Village Green, Frampton-on-Severn" (13), with the rounded masses of foliage and placid water reflection, and without doubt this is one of the best landscape studies. Her sketch of "Chain Gate, Wells" (74), is solid and broadly handled, the old gateway and tower of cathedral standing in strong shadow against a light sky. "Gateway, Chioggia" (140), is also a nice sketch, and firm in drawing, not always met with in ladies' work. Wiggis Kinnaird's "The Severn near Shrawley" (7), is worth notice for its delicate treatment of colour. The president (Mr. Walter Severn) has three or four subjects. His "Sunset, Biarritz" (10), is a carefully executed and effective view, and is in pastel. His "Como, after Rain" is more smooth and mannered; his best work is "Gorse in Full Bloom," a rich harmony of golden hue under a grey sky. "Scared," by Geo. Rushton, has the elements of good drawing and arrangement, and H. Sylvester Stannard's "Village by Sunset" (23) is pleasing. A Duassut is a subtle delineator of landscape. His "Surrey Lane" (32) is finished and delicate with its leafless trees; and "The Outskirts of the Village," "Old Cottages, Amersham" (254), "Golden Sunset" (354), and other small sketches are feelingly done and extremely delicate, and are all dainty harmonies of colour. In quite a different style is Miss Evangeline Jex-Blake's work, No. 39, "The Vestner Thor, Nuremberg" (39), "View of Wells Cathedral and Glastonbury Tor" (68), are delightfully broad and true. Solid in handling is "Near Hengistbury Head, Hants" (155), and a nice suggestion of atmosphere and breadth of colour is seen in her view of "Verona" (266). We pass a few tame and weak drawings, like "A Quiet Summer Evening on the Stour" (52), and come to one of Henry Terry's specimens of portraiture. His "Old Buckinghamshire Locomotive" (55) is pleasant as a piece of *genre*. The old woman with her lace, and the young girl with a basket of provisions, are drawn with Mr. Terry's usual truthfulness. There is a harmony of grey tones and browns and russets in Berenger Bengier's delicately-wooded landscape (65) "Sad December." There is also a sympathetic note in it. Frances E. Nesbitt's "Thrashing Corn" (70), is an honest piece of work. There is movement and vigour in the farm labourers busy at their threshing operations, and the colour is admirable. Miss Maud Turner's figure subject "At the Sign of the 'Red Dragon'"—a country girl feeding pigeons at the door of an inn—is drawn feelingly, and the colour is pleasing. No. 73, "On the Grand Canal, Venice," by D. W. Hereford, is harmonious in colour; light and atmosphere are given by

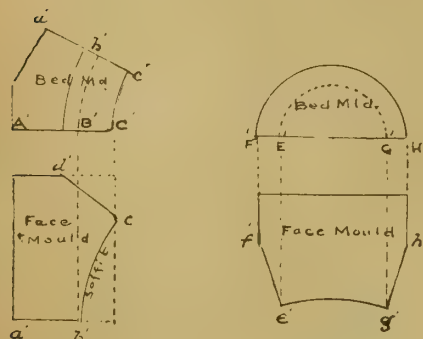
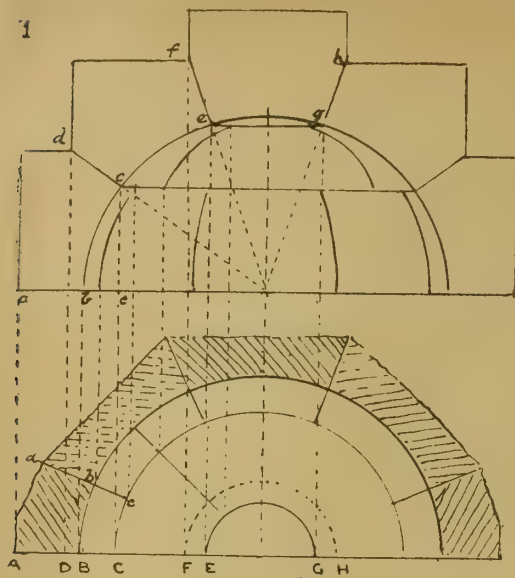

Niche

thin and transparent handling. Next, Albert Stevens contributes a fine view of "Mentone" (78), taken from the hills at the back of town. The bay and town nestling between the hills is effective. "Near Cape Martin" (153), and a clever sketch of moor with its rough heather and gorse, "Harlow Moor, Harrogate," may also be noticed as examples of the industry of this painter. The gallery would be incomplete without a specimen of L. Block's finished work in still life. The minuteness of the old volume open, with the engraving and the soiled plate, is marvellously realistic. There is admirable effect in the view of "Sand Hills, Pas de Calais" (80), by Miss Rose Douglas. This lady artist is an expert in the blending of wet colours. Stiff and unnatural is "A Rehearsal" (82); H. W. Mesdag has a nice sketch (83); Miss Maud Turner's "Study of a Head" is meritorious for its colour and pose—rich auburn hair tied up with a band of blue ribbon. There is a want of atmosphere in the distance of H. Sylvester Stannard's landscape (100). We note a sketch by L. Burleigh Bruhl for its nice tone and wooded banks, "On the Wye," and Harriet Skidmore's very masterly rendering of the sea, breakers, and surf over rocks (111). Mrs. Mariquita Moberley (121) sends a sketch of Ruskin's study at Brantwood, interesting as showing the homely tastes of the great art critic and writer. The fireplace has over it a ceramic panel representing the Virgin crowned by angels, and at the sides are shelves of old pottery and books, treasures of the author. H. W. Mesdag, of the Hague, sends three masterly sketches in monochrome—seascapes in black and grey. "In Danger" (129), a boat, with crew, flying signals of distress in a rough sea; "Rough Weather on the Dutch Coast"; and "The North

Sea" (163)—all faithful renderings of rough sea and swelling waves in black and yellow tone in broad vigorous dashes of the pencil. Rose Douglas's view at Etaples (160) is a broad and grey-toned sketch showing power. No. 165 "Blue Bells, Epping Forest," by H. G. Stormont, is a delicate and dexterous piece of work. We may also note the work of Mrs. Jane Inglis "Whitby" (187), a nice sketch of red-tiled cottages climbing hill; and a bright sketch of the same place, "Bringing in the Fish," by another lady, Ethel Kirkpatrick (188); also a view of St. Bartholomew the Great, by Miss Rickenbach. Another lady, Mrs. James Jardine, sends a vigorous sketch of "Filey Brig," a rocky piece of sea-coast cleverly done. Miss Turner has a pleasing figure study, "Cinderella" (190), Miss B. Wigan a brilliant sketch of a Gipsy Encampment (205), Lexden L. Pocock a study by the riverside in the dusk of evening (203), and F. A. Howarth a pleasing study of "Table Mountain, Robbin Island." Miss M. A. Cooper's pots and wallflowers "Ready for Potting" (212); a pair of little sunset landscapes by George Marks, a clever sea-piece with boats getting ready for the tide (218), by C. Topham Davidson, are worth passing notice. The ablest coast scene is T. S. Hutton's "Cemaes Bay, Anglesey" (226), a large and skilfully handled coast view: the waves are breaking over a rocky shore, and there is motion and freshness imparted. The flock of sea-birds gives life to the scene. David Green's sketch of "Springtime" (229), is broad, and the colour fresh. One of the finest landscapes is Mrs. Mary Stevens's "Summer Time in the Engadine" (258), quite Whirterian in manner, the wild flowering grass on the valley sides and the distant hills are delicately and effectively painted. Miss Bessie Wigan's "Over the Linton Moor," and Miss Janet Fisher's work (260), and a few other

drawings and sketches by J. Maud Peel (272), M. Rose (273), Gertrude Crompton (280), J. Carlisle (300), Reginald Jones (310, 296), Lady Adelaide Tylour (292), Miss Pughe's figure of a Cavalier, may be mentioned as works of merit, besides a few on the screen. There are many feeble and tame productions which detract from the character of the exhibition.

#### MODEL SPECIFICATIONS.—XVII.

##### MASON.

IN the specification of particular works it is as well to preface the clauses by saying what particular kind of stone is to be used, the modes of fixing and jointing, whether by metal or slate dowels, their length and substance, or cramps of bronze, and the material—lead or Spence's metal—used for running in the same; the kind of joggles, as V-joggles. The sizes of all details not figured in the drawings ought to be always given; for example, the extreme dimensions of sills, architraves, jamb mouldings, mullions, cornices should be stated, the beds of these items, heights of stones for jambs and columns, lengths of stones for cornices, &c. In our clauses we have only suggested dimensions; but they are necessary for the quantity surveyor as well as the mason. A general clause ought to be inserted as to the beds and joints, the kind of finish to face, the pointing, and that the work is to be cleaned down at completion and left perfect to the architect's approval. In specifying Bath stone and other kinds, it is necessary to say that the stones are to be well seasoned and hard, shown by their resistance to the pressure or point of a tool, and sometimes it is specified that the stone is to be selected by the architect or clerk of works. For steps, sills, landings, and stairs, the

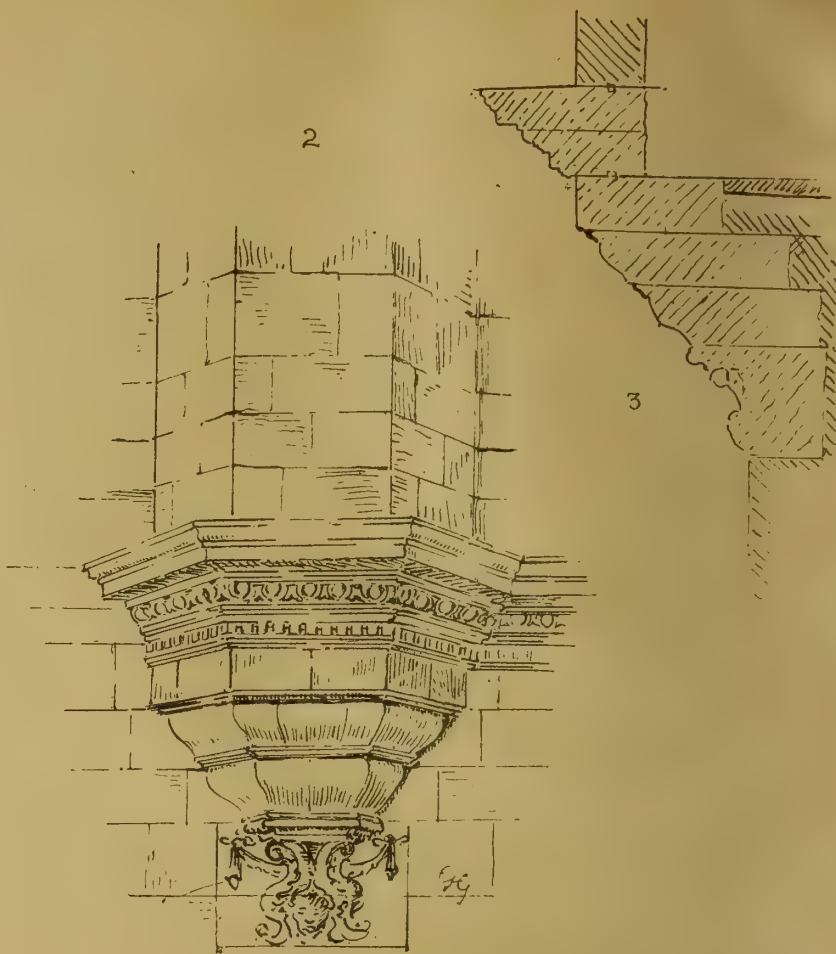



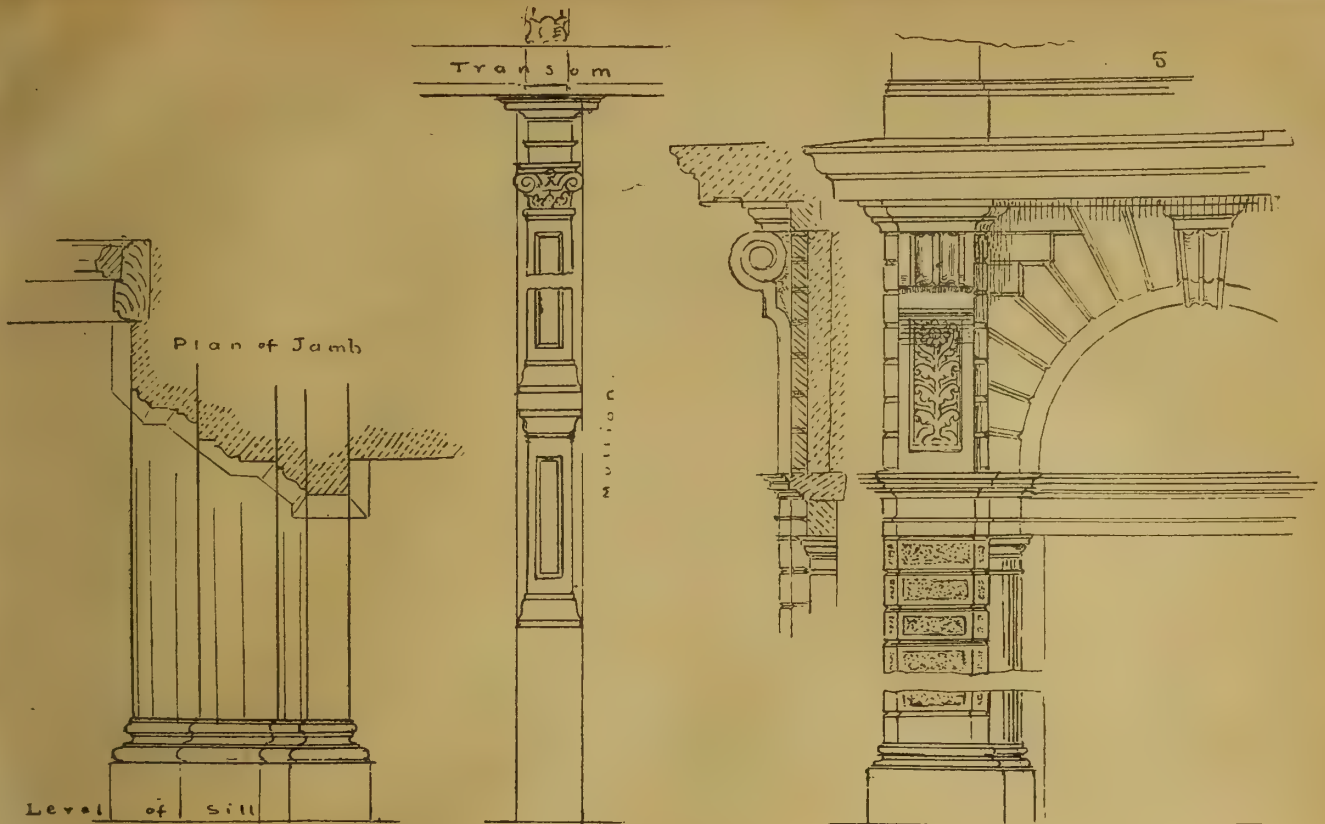

older the Portland stone is, the harder and more suitable. The selection of stone for such features as dressings, columns, niches, and other details is essential. If of Portland, the bed should be specified as "Whitbed," or if of Bath, they should be of Box Ground, Corsham Down, Combe Down, or Monks Park, which are all good weather stones, and the latter fairly compact and even-grained. But only experience of quarries and working can give the requisite qualities; as sometimes it is better that the requirement as to quarry bed in setting is not enforced. But for columns, architrave dressings, cornices, and other exposed stonework, this ought to be required.

The neglect of setting stone on its natural quarry bed is constantly seen in London. All oolitic and arenaceous stones (sandstones) should be laid on their quarry bed. We see the laminae of sandstones placed on edge—equally absurd, as it has been remarked, as placing a weight on the leaves of a book standing on edge, and also allowing moisture to enter.

Our first diagram shows how a spherical niche head is formed with horizontal splay beds and vertical joints. The plan and elevation with the dotted vertical lines will sufficiently explain how the radiating joints of elevation are obtained from projectors of plan, as, for example, those of *A B C*, &c., on plan determine the joints in elevation, *a, b, c, c d, e f*, &c. To obtain the joints of the stones on plan or the spherical surface, ordinates are projected from the points of elevation corresponding, and the concentric circles described at the points so obtained on the horizontal line, *A B C*, &c. These give the horizontal lines of splay joints in the spherical surface of head. For breaking joints these semicircles are divided equally into four parts, as shown alternating. Radiating lines drawn to centre of plan will give the joints on plan. The vertical joints in elevation are obtained by projecting ordinates from plan, as shown by dotted lines. The springers or first stones of the head of niche will be of less thickness than the others in the lower course (about one half), in order that they should break joint with the vertical joints of course above. For this purpose

on the outer circle, *B* on plan, set off the first radiating joints *a c*, and the corresponding joint, equal to half one of the three other stones, as shown in plan. The method of finding the bed-mould and face-mould of springer is shown by the diagrams below the plan, and will be easily understood as being produced from the prolongation of the same vertical ordinates *A B C, c d*, &c. The face-moulds may be transferred from the elevation *a b c d*, and the same with the course above, *c d e f*. The stone used to work this will be a wedge-shaped prism. We also show how the bed and face-mould of keystone is obtained. The bed-mould is transferred from plan, and the face-mould from elevation.

Corbels and corbelled projections are important items of wrought stonework. Provision should be made for tailing the lower stones into the wall, pinning them with slate and cement, and bonding the work. Unless a drawing with dimensions is given, the dimensions of the stones, their length, including the part tailed into wall, and their length if moulded or splayed, or enriched by carving, should be stated, whether any of the stones are to be plugged with lead, dowelled, or cramped. Sketch (Fig. 2) shows a moulded corbel with carved springer in four or five courses, and a section showing the courses. For small corbels, two courses would suffice. A single stone could be used for the lower course, and another including the projecting and enriched cornice (see clause 40).

The design for jamb mouldings (Fig. 4) and mullion for a window of the Renaissance character, shows an architrave with two faces projecting 3in. from the wall face of ashlar, which may be worked in two stones at the first reveal (see plan). The outer projecting part of the architrave may be 8in. deep, and the inner part 9in. or 10in. rebated for wooden frame. The mullion is enriched by a pilaster on face, with pedestal and capital; above the transom it is carved as a half-baluster. We also give details for a stone doorway with projecting cornice resting on carved trusses, and with rusticated piers and arch. Clauses are given for these details.

39. Niches.—The niches shown in elevations (or details) to be constructed out of selected blocks of Portland stone, the head to be in two stones hollowed, jointed in centre, and to be 4in. (or 6in.) thick in the thinnest joint, well grouted with Portland cement; the cylindrical part of niche to be of solid stones in two courses the full height of niche from base to springing. The vertical joints to break joint, and to be equally arranged on each side, well filled behind with cement, and to be made to bond with the wall. The architraves and pediment to be executed according to details (see Figs. 6 and 7, page 805). Or—

The spherical niche (see sketch 1) to be executed according to large scale (or full-size drawings). The stone to be of selected blocks of Portland (or other stone), and the head of niche to be constructed with splayed horizontal beds and vertical joints in three courses, set out from proper bed and face-moulds according to rule. The beds and joints to be correctly and truly worked to even surfaces, the keystone to be joggled. The courses of the head to be cut out of solid stones not less than 6in. thick in any part, and to be well bonded, and filled in at back with cement. The cylindrical part of niche to be of two or three courses in height, three vertical joints under the springing and four joints alternately, well bonded to wall and grouted in cement. Or—

The niche-head to be formed with vertical radiating joints; describe number of stones, worked according to bed and face-moulds with true and accurate surfaces. Below the springing the stones to be in two or three courses of not less than 6in. (or more) in thickness, breaking joint, and well bonded to walls.

40. Corbels.—The projecting windows (marked *A* on plan), are to be carried on a 4in. hard tooled York stone landing (8ft. by 3ft.) in one piece, cut and pinned into wall in cement. (If stone trusses underneath are used, describe the length and depth of truss and the distance it is to be tailed into wall.) See sketch.

The Portland stone corbels to turrets to be as shown in detail drawing in two (or three) moulded courses, which are to bond into wall to a depth of at least 9in. (or 12in.), the stones being plugged with lead at the joints, and dowelled at the beds with metal dowels in cement (if thought necessary). The corbel stone in the lowest course to be carved to full-size models approved by the architect. Or—

The corbellings under octagon turrets to be as shown in detail (sketch 2), in four courses, with mitred returns of wrought and moulded and enriched Portland stone, bonded into wall at the sides; the lower two courses to be tailed into the masonry at least 18in., and the outer end of bottom course to be carved to a full-size model approved by the architect. The upper course of corbel to form an enriched cornice, with egg-and-tongued and dentil enrichment. All requisite joggles or dowels and cramps to be used.

41. *Core to Corbel Cornice.*—The main cornice to have a rough York stone core 3in. thick tailed into wall 12in. (or 18in.), in lengths of not less than 5ft.
42. *Columns and Pilasters, &c.*—The columns and pilasters to doorways and window dressings to be monoliths (or in two or three blocks of stone). The pilasters to be bonded not less than 4in. (or 6in.) into the wall. The entablature and pediments to be executed with all requisite joggles and cramps of metal or slate, and the apex of pediment to be in one stone. The caps and bases to be in large stones bonding with the masonry.
43. *Doorway* (see sketch 5).—The jambs to be worked according to detail with Portland stone, three-quarter columns 5in. diameter, cap and base set in the angle between reveal and rusticated pier, with wrought-stone entablature over to form a transom. The recessed arch over column to be square in section, with sunk panel and enrichment (see detail), with radiating joints to bond into masonry. A moulded keystone to be executed to the architect's satisfaction. The side trusses above impost mouldings to be executed according to models approved and carved to the architect's satisfaction. Each to be 2ft. by 18in. and 4ft. in height, extreme dimensions, securely tailed into wall. The projecting cornice (or head) to be weathered moulded on edges, with bed-moulding, mitred round trusses, and keystone, and it is to be securely tailed into wall at least 12in. or 18in. The soffit to be sunk (or panelled), and to have proper drip. The cornice to be channelled and plugged with lead at the joints. Or—

The main doorway to have moulded and carved jambs and arch according to detail drawing (describe if the arch is rusticated or moulded and sunk on face or carved), with voluted keystone carved according to model prepared from drawings, the radiating joints or beds to be truly worked to bed- and face-moulds, and the stones of jambs and arch to be rebated to receive the frames. The jambs to have through bonders every third (or fourth) course. (If a circular hood instead of a flat cornice, specify to be formed of three or five stones with radiating joints, the inner ends to go into wall 9in. or 12in., and to be pinned securely in cement with sunk panels on soffit, mitred bed-moulds over trusses. Each joint of hood to be plugged with lead.)

#### SOCIETY OF ENGINEERS.

AN extremely interesting visit was made by a party of the members of the Society of Engineers on Tuesday, the 14th inst., to the works of the Gaslight and Coke Company at Fulham, and the Gigantic Wheel at the Earl's Court Exhibition. Amongst those present were Mr. W. Worby Beaumont, president; Mr. H. Adams, past-president; Messrs. J. Patten Barber, J. Bernays, G. Burt, D. B. Butler, Percy Griffith, R. St. George Moore, M. Wilson, members of council; and Mr. G. A. Pryce-Cuxson, secretary.

#### DESCRIPTION OF THE GASWORKS.

The coal received, amounting to 130,000 tons per year, is unloaded by Hone's patent single chain grabs (capacity 1 ton, each lifting 45 tons per hour), and deposited into bunkers, from which it is distributed to the several retort houses by small waggons. When storing coal in the open it falls down shoots from the bunkers into a conveyor of the push-plate pattern, and is carried along to the storage ground, where it is dropped from a shoot at the end of the conveyor into small waggons, which are run and tipped so as to form a heap of an average depth of 10ft. to 12ft. The total coal storage is 30,000 tons; 14,000 in retort houses and 16,000 in the open. The retort houses, of which there are six, have a capacity of 9,000,000 cubic feet per 24 hours. They contain 760 retorts 20ft. long, and are heated by generator furnaces, which require about 20 per cent. of the total make of coke for fuel, leaving 80 per cent. for sale. The heat of the retorts is about 2,100° Fahrenheit, and on the average 10,000 cubic feet of gas are distilled from 1 ton of coal, each retort producing about 12,000 cubic feet of gas per 24 hours. The exhausters—rotary pumps—are used for the purpose of exhausting the gas from the retorts, and forcing it through the purifiers and other apparatus into the gas-holders. The condensers—stacks of pipes through which the gas flows up and down—are for the purpose of reducing the temperature to about that of the atmosphere, and of removing from the gas all tarry or solid particles. The scrubbers—tall towers in which are placed beds of tightly packed coke or boards on grids, and

down which ammoniacal liquor or water is sprayed—are for the removal of the ammonia from the gas, which travels in an opposite direction to the water. A considerable proportion of sulphuretted hydrogen and carbonic acid is also removed in the scrubbers. The purifiers are rectangular boxes, with lids sealed by water lutes, in which are placed the purifying materials in layers, usually six, and of a depth of about 4in. The impurities in the gas when it arrives at the purifiers are carbonic acid, sulphur existing as carbon bisulphide, and sulphuretted hydrogen, which are eliminated by slaked lime, oxide of iron, and weldon mud, the last two materials, however, being only used for the extraction of the sulphuretted hydrogen. The gas, after leaving the purifiers, passes through the station meters, where it is registered, and thence into the gasholders.

#### DESCRIPTION OF THE GIGANTIC WHEEL.

The Great Wheel at Earl's Court, although entirely of English manufacture, is more or less an American innovation. Mr. W. B. Basset prepared the drawings, with the aid of Mr. J. J. Webster, M.Inst.C.E., consulting engineer to the company. The Gigantic Wheel and Recreation Towers Company was formed, and in March, 1894, the work commenced. The foundations consist of eight solid cubes of concrete, each weighing over 250 tons, with steel bolts 16ft. long bedded into them, and to which are attached the bases of the eight columns. These columns are each 4ft. square, built of steel plates with internal diaphragms. The first and second lengths of these columns were hoisted into place by a 96ft. pair of shear-legs. To erect the upper lengths of the columns, a wooden stage was built across the gap through which the wheel now revolves, and on it two Scotch cranes were set up, one to work on each side. About the middle of July the columns were completed, and the great axle, built of 1in. steel plates and 9in. steel girders bent into circular form, was brought from Messrs. Maudslay's works at East Greenwich to Earl's Court. To hoist it into place the wooden bridge was used, with a strong trolley fitted on it to run on rails. With tackles hung from this trolley, the bearings, weighing 11 tons each, and the axle, weighing 57 tons, were hoisted. The first quadrant of ten spokes was built in the following manner:—A spoke was hung from the axle, the length being carefully adjusted to gauge, and the portions of the periphery, or outer ring, were attached. Two powerful tackles, capable of exerting together a pull of 120 tons, were fixed to an anchor-post, and towards this anchor the spoke was hauled out of the way when finished. Another spoke was then hung in its place, and connected to its periphery girders, and in this manner the ten were hung and adjusted until the quadrant was hung so that the last spoke erected was vertical, when the steam-winch actuating the tackle could pull no more. The second quadrant was built from a scaffold 150ft. high; the first and second quadrants balanced each other, and all the strain was thus removed from the anchor. For the third quadrant, a strut, which weighed alone over 60 tons, was securely fixed in the first quadrant; the tackles and anchor were again brought into play. The fourth quadrant was erected by building the inner periphery girder, by aid of a hanging scaffold, to bridge the distance between the first and third quadrants, and from it the outer periphery and spokes were erected. The last two bolts in the outer peripheries were driven by Mrs. Walter Basset at a height of 280ft. on April 26th. Since the completion of the Earl's Court Wheel, Mr. Basset has, with the help of his two assistants, Messrs. C. F. Hitchens and H. C. Booth, A.M.I.C.E., designed and erected a gigantic wheel at Blackpool, and another at Vienna, and is now engaged on the erection of one in Paris larger even than the Earl's Court Wheel. A comparison between the methods adopted both in the design and erection show the result of experience, combined with careful study. The weight of steel used in the Earl's Court wheel, amounting to 1,200 tons, has been reduced in the Paris wheel to 783 tons, although the Paris wheel is the greater, without in any way jeopardising the safety of the public. The axle, instead of being of boiler plates 7ft. in diameter, is a solid forging, 26in. in diameter, weighing 32 tons. The cars are hung on cantilevers, instead of between the periphery girders, giving a lighter and more graceful appearance. The erection is

effected by means of two Scotch steam cranes with jibs 100ft. long, on stages 250ft. high. These are believed to be the highest crane-stages ever used. By means of these cranes every portion of both columns and wheel are lifted direct into position with the exception of the axle which was lifted on the 7th April by means of wire rope tackles.

#### ELECTRIC LIGHTING NOTES FOR ARCHITECTS.—XXIV.

By AN ASSOC. INST. ELECT. ENGS.

INCANDESCENT LIGHTING—(continued).

**CANDLE-POWER, VOLTAGE, AND CURRENT.**—The amount of light emitted from different-sized lamps varies considerably, and the purposes for which glow-lamps are now used also vary considerably. They are used for illumination purposes, as in house-lighting; for adornment and decoration, as in illuminating jewelry, flowers, headdresses, &c.; and in medicine, surgery, and dentistry. They are, therefore, made in a great variety of patterns and sizes, and are also made to work at voltages varying from 2 to 230 volts, according to circumstances. Glowlamps are therefore known as 5-volt, 60-volt, 100-volt, or 220-volt lamps, as the case may be. Now, from an engineering point of view, the value of a lamp depends upon its efficiency, so that it is necessary to investigate the relationship between the amount of light emitted and the amount of electrical energy supplied. To enable us to do this, we must now refer to several important factors in detail, which have to be taken into consideration in such determination. For instance, the amount of light emitted, or the illuminating power of a glow-lamp, is measured and expressed in terms of the light emitted by some standard under definite conditions, and it may be remarked here that the question of a luminous standard is still one of controversy, no one standard of illuminating power having as yet been universally adopted. The requirements of such a standard are obvious; it should be a source of light perfectly definite, invariable, and easily reproduced—a candle for use as a standard should be one of definite composition, burning at a definite rate, under perfectly definite and fixed conditions. In this country and the United States the standard of illuminating power is the *Standard Candle*, which is a sperm candle weighing six to the pound, and burning at the rate of 120 grains per hour. A glow-lamp of 8 candle-power (8c.p.) is thus one that gives out as much light as eight standard candles, and incandescent lamps are usually designated 5c.p., 8c.p., 16c.p., or 32c.p. lamps, according to their illuminating powers.

Now, since light is radiant energy, probably the best definition of illuminating power is as follows:—The illuminating power of a source of light is the quantity of light which falls upon unit surface at unit distance from the source, the unit surface being placed so as to be perpendicular to the rays. This definition assumes that the source emits light uniformly in all directions, as then the amount of light falling upon the unit surface would be directly proportional to the total quantity of light emitted by the source. The determination of the candle-power of a lamp is obviously an important operation, for which purpose some form of *photometer* is used. The subject of photometry is generally well treated in the standard textbooks on Light, to which we refer students not well acquainted with this subject. As the battle of luminous standards is not yet decided, it will be, however, interesting to briefly describe the chief standards which have been proposed.

The *Carcel* lamp, proposed in France, is of definite dimensions, burning 42 grammes of colza oil per hour. The objection to this as a standard is that it does not preserve its uniformity long at a time, and the precautions which have to be taken, and the regulation required to eliminate several sources of error are tedious, and render it unsuitable for continuous use. The *Vielle* lamp, of molten platinum, has also been proposed, and, although it was adopted by the International Paris Conference of 1881, it is too impracticable to render it fit for general use. The *Hefner-Alteneck* lamp, adopted in Germany, is simple in construction, easy to manipulate, and not troublesome. This lamp is of definite dimensions, burning amyliacetate, with a flame 4 centimètres high. The *Reichsanstalt Unit* has also been used in

Germany, it being the light emitted from one square centimetre of platinum raised to a definite high temperature. Another lamp proposed in this country is the *Vernon-Harcourt* lamp, which is a simple lamp burning the vapour of standard quality pentane with a flame of such a size to give a light equal to two standard candles. The relationship between the above standards has been stated to be as follows:—

One standard candle = 0.1053 Carcel = 0.0506  
Vielle = 1.14 Hefner-Alteneck.

Generally speaking, glow-lamps are made to give candle-powers varying from  $\frac{1}{4}$ c.p. to 100c.p., the candle-power of a lamp depending upon nature, shape, and dimensions of the filament; and, assuming uniformity of material, it depends upon its total superficial area—i.e., its length and thickness. The length and thickness also decide the pressure at which the current is to be supplied, whilst the sectional area of the filament decides the current required. Thus, by suitably arranging the voltage and amperage, a long thin filament may give the same candle-power as a short thick one. Furthermore, lamps giving the same candle-power, and having the same efficiency, absorb the same amount of energy—i.e., the same number of watts, and since the watts absorbed equal the product of the voltage and amperage, it is obvious that as the volts increase, the current required will be diminished, and *vice versa*. For the purpose of explanation, we may consider the 100-volt 16c.p. lamp as a standard of reference, since it is so generally used, and, taking the energy absorbed as 60 watts, it is clear that at 100 volts pressure such a lamp takes 0.6 ampere. If a 16c.p. lamp with the same efficiency be required to work at 60 volts, then the current will be one ampere. At 50 volts the current will be 1.2 amperes. Now, since  $R = E \div C$  (Ohm's Law), the resistance of the 100-volt lamp filament will be  $100 \div 0.6$ , or 166.6 ohms, the 60-volt lamp  $60 \div 1$ , or 60 ohms, and the 50-volt lamp  $50 \div 1.2$ , or 41.6 ohms; and, as we have already indicated, the filament diminishes in thickness as the voltage increases. There is thus evidently a certain voltage at which each lamp should be run, and it is soon found that if the voltage is varied much there is considerable difference in the light emitted. It has, in fact, been shown that the candle-power of an incandescent lamp varies as the 6th power of the E.M.F., the 5th power of the current, and the cube of the energy expended. The following is the result of a test of a 16c.p. 50-volt lamp with different currents:—

Candle-power..	0.4	5.1	15.8	50.7	103	141
Current .....	0.56	0.9	1.06	1.29	1.48	1.58
Volts .....	25	40	56	62	72.5	80
Watts .....	14	36	59.3	80	107	126

It is apparent that engineers should keep the fluctuations in the voltage a minimum (certainly not more than 1 or 2 per cent) by paying proper attention to the generators, engines, and governors; otherwise the lamps, especially those with high frequency, will give way, and so shorten enormously their life.

**Efficiency and Life.**—The term *efficiency* denotes the ratio between output and input, or—

$$\text{Efficiency} = \frac{\text{output}}{\text{input}}$$

and, as such, the efficiency of an incandescent lamp should theoretically be the ratio of the energy in the luminous rays to the total electrical energy absorbed by the filament; usually, however, by the term "efficiency" is meant the *specific illuminating power*, or the ratio of the illuminating power of a lamp to the electrical power absorbed; that is to say the efficiency of a lamp—

$$\begin{aligned} &= \frac{\text{Number of candles yielded by the lamp}}{\text{Number of watts absorbed by the lamp}} \\ &= \frac{\text{Number of candles per watt}}{\text{Candle-power per watt}} \end{aligned}$$

Therefore, the greater the value of this ratio, the higher the efficiency, and for a new lamp the efficiency varies from one-third to two-ninths candle per watt. It is somewhat strange that lamp manufacturers often incorrectly express the efficiency of a lamp by taking the ratio of the electrical energy absorbed to the light emitted (i.e., watts per candle-power), which, of course, gives the actual *specific activity*, and not the efficiency.

This is obviously the reciprocal of the actual efficiency, since the greater the value of this ratio (specific activity) the greater the inefficiency of

the lamp, so that the real efficiency of a  $3\frac{1}{2}$  watts per candle-power lamp (as given in trade catalogues) is  $\frac{1}{3.5}$  or  $\frac{2}{7}$  candle per watt. The efficiency of a glow-lamp really depends upon the temperature to which the filament is raised, and as we have already indicated a lamp is more efficient the higher the temperature at which it operates, since the light emitted increases much more rapidly than the energy supplied, so that the efficiency of a lamp increases with the power

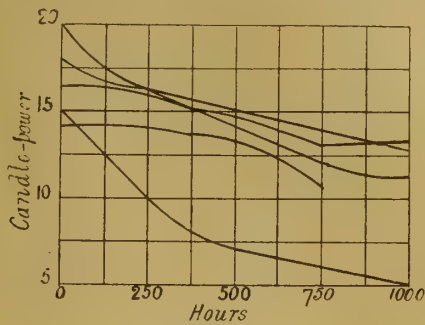

FIG. 83.

supplied to it; but, as would be expected, the duration of its existence is diminished.

When a new lamp is supplied with current at the constant pressure for which it was designed, say 100 volts, it is found usually that its illuminating or candle-power gradually decreases; in other words, its efficiency diminishes. This is due to the fact that the filament is gradually being disintegrated, so that its diameter is reduced and its resistance increased. A secondary result also occurs, in that the fine particles of carbon are deposited on the inside of the glass bulb as a black semi-opaque coating, which diminishes the illuminating power by obscuring the bulb. This disintegration and reduction of the filament is due to (1) mechanical, (2) chemical, and (3) physical causes. Thus, (1) the occluded gases in the surface layers of the filament are evolved explosively; (2) chemical combination takes place between the carbon and some of the constituents of the remanent gases, and (3) dissociation, volatility, and evaporation of the carbon take place under the influence of the high temperature and electrostatic attractions. Furthermore, considerable increase emissivity of the surface takes place, in consequence of the surface change due to the reduction of the cross-section of the filament, the result of which is that the same quantity of activity per unit surface is radiated at a lower temperature.

Experience has shown that the falling off in

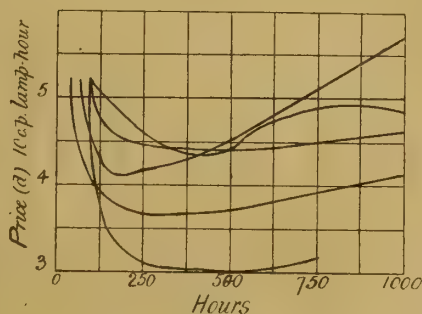

FIG. 84.

candle-power during the life of a lamp is far more rapid with high-voltage lamps than with low voltage ones, and from comparisons made between flashed and unflashed filaments, it has been found that the efficiency of unflashed filaments decreases in a given number of hours by a far greater percentage than is the case with flashed filaments—in other words, the change in the candle-power is slower at the same efficiency with filaments of low specific resistance and low emissivity (flashed) than with filaments of higher specific resistance and great emissivity (unflashed). Now, the question of the life of a lamp is an important one, and from what has been said it is clear that the gradual diminution of light with age implies that a time is ultimately reached

when the efficiency is so low that it is more economical to replace the lamp with a new one, although the filament may not be broken. In fact, cases have been known in which the efficiency of a lamp of long life has fallen to  $\frac{1}{4}$  candle per watt. In some cases the filament breaks before this stage is reached. The length of time during which it will be advantageous to continue the use of a lamp can only be decided by investigating its *economical efficiency*, the value of which is determined by considering the diminution of efficiency with age, cost of lamp, its life, and the cost of the energy supplied. The most economical efficiency is that at which the cost of working the lamp is a minimum. If the lamps are good and inexpensive whilst the cost of the energy is high, then the lamp should have a high efficiency, and with inferior and costly lamps and cheap energy, the efficiency of the lamp should be low. It has been shown that the total cost of energy and lamp renewals is a minimum when the cost of lamp renewals is about 15 per cent. of the whole. If above 15 per cent., the efficiency of the lamp is too high.

To indicate the moment in the existence of a lamp when it is most economical to replace a lamp with a new one, Mr. O'Keenan has introduced the term *smashing-point*. This point is determined by plotting a certain number of curves showing the peculiar characteristics of a lamp, and enabling us to estimate its value at any instant of its existence from various points of view. All these curves are plotted with hours of service as abscissæ, and with the following quantities as ordinates:—

- A.—The electric energy in watts consumed at any instant.
- B.—Candle-power (Fig. 83).
- C.—Energy consumed (watt-hours) since the lamp was put into service (i.e., the integral of curve A).
- D.—The quantity of light produced by the lamp (candle-hours) since it was put into service (i.e., the integral of curve B).
- E.—The cost of the energy (in pence) consumed by the lamp since it was put into service. Curves C and E may be made one by a suitable choice of a scale of ordinates.

F.—Total cost of the lamp (in pence) since being put into service; a curve which is obtained by raising the curve E by an amount equal to the price of the lamp.

G.—Specific cost (Fig. 84) at any instant, in pence, per candle-hour; obtained by taking the ratio of the ordinates of curves C and D.

$$\text{Specific cost} = \frac{\text{Total cost in pence}}{\text{Quantity of light in candle hours}} = \text{Total cost per candle per hour.}$$

This last curve characterises every type of lamp working in a given manner. It shows, generally speaking, that during the first hours the specific cost, asymptotic to the axis of *y*, rapidly diminishes, then falls more slowly to a minimum, and then ascends indefinitely, owing to the reduction of the candle-power. There is, therefore, a moment at which a given quantity of light has been obtained for a minimum price. It is precisely at that moment that we must remove the lamp, replace it, and break it, or rather, return it to the maker, and obtain a small sum for it.

In the early days of electric lighting, it was usual to estimate the value of a lamp by its *initial* consumption of energy in watts per candle, and by the *average* life guaranteed by the makers. The two desirable qualities of an incandescent lamp are, however, now considered to be:—

- 1. Large percentage retention of original candle-power during its life; and
- 2. Large average percentage retention of original efficiency during its life.

The following results obtained by Messrs. Siemens and Halske prove that if an initial efficiency too high be adopted, the constancy is inferior:—

- 1½ initial watts rose to 4.46 watts after burning 55 hours.
- 2 initial watts rose to 3.99 watts after burning 90 hours.
- 2½ initial watts rose to 3.58 watts after burning 150 hours.

We also include a table containing the mean

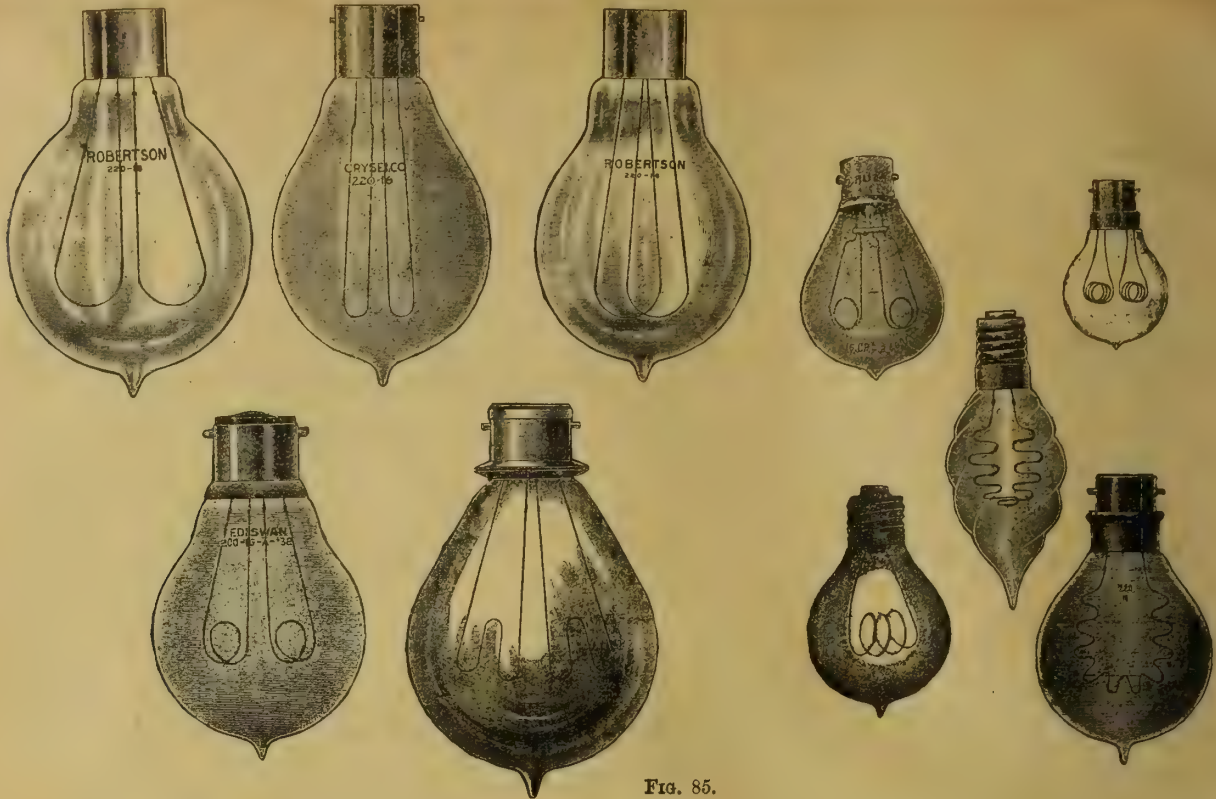

FIG. 85.

values of tests of more than 500 lamps of 49 different types.

Hours after start.	Initial consumption in watts.									
	2.0 to 2.5		2.5 to 3.0		3.0 to 3.5		3.5 to 4.0		4.0 upwards.	
	c.p. in percent.	Watts per c.p.	c.p. in percent.	Watts per c.p.	c.p. in percent.	Watts per c.p.	c.p. in percent.	Watts per c.p.	c.p. in percent.	Watts per c.p.
0	100	2.4	100	2.9	100	3.3	100	3.8	100	4.5
100	84	2.3	98	3.0	95	3.4	96	4.1	96	4.7
200	70	3.3	85	3.3	91	3.5	91	4.3	92	4.9
300	59	3.7	81	3.5	88	3.6	86	4.5	87	5.2
400	53	4.2	76	3.8	84	3.7	81	4.7	82	5.4
500	48	4.6	71	4.0	79	3.9	77	5.0	75	5.8
600	45	4.8	67	4.2	76	4.1	73	5.3	72	6.1
700	41	5.2	64	4.4	72	4.2	69	5.6	68	6.4
800	39	5.3	62	4.7	69	4.4	66	5.9	65	6.6
900	38	5.5	59	5.0	67	4.7	63	6.1	62	6.9
1,000	37	5.7	56	5.3	64	5.0	60	6.3	60	7.0
1,100	36	5.7	53	6.0	62	5.4	58	6.5	58	7.1
1,200	35	5.8	50	6.3	59	5.6	46	6.7	56	7.1

Professor S. P. Thompson has prepared the following table to show the effect of an increase or decrease of voltage on the life and light of a 10c.p. lamp made for working on a 100-volt circuit:—

TABLE OF AVERAGE CANDLE-POWER AND EFFICIENCY OF LAMPS AT DIFFERENT PERIODS OF THEIR LIVES.

Volts .....	95	96	97	98	99	100	101	102	103	104	105
Life.....	3,595	2,751	2,135	1,645	1,277	1,000	785	601	477	375	284
Candle-power.	7.4	7.8	8.3	8.8	9.3	10	10.7	11.3	12	12.6	13.3

**High-Voltage Lamps.**—In the articles on distribution we frequently referred to the advantages of high-pressure distribution, and when we remember that higher voltages facilitate a large supply from one centre, and consequently tends to lower the cost by spreading the nearly fixed charges, we can readily understand why central-station engineers have introduced high-voltage lamps in consumers' premises, and have produced a demand for such lamps. It is equally obvious that there will be mechanical difficulties in the construction of these lamps, and that the manufacturers must experience practical difficulties in disposing the long filaments of the high-voltage lamps in bulbs of the same size as used for lower voltages. By high-voltage lamps is meant lamps requiring pressures varying from 200 to 230 volts, and for the same candle-power it is clear that the filaments of these lamps will be long and of small cross-sectional area, as compared with the shorter and thicker filaments of the 100-volt lamps. To give some idea of the dimensions of the new filaments, we may state that for a 230-volt 16c.p. lamp the filament is about 14 or 15in. in length, and  $\frac{1}{30}$ th of an inch in diameter, and forms, in

fact, a very flexible pendulum. Not only is there the difficulty of disposing these long, thin filaments in a small space; but the disturbing effects of gravity and electrostatic charges on the bulbs have also to be taken into account, in consequence of which most of the high-voltage lamps are unsuitable for burning in any but a vertical position, the cap being uppermost. In the inclined or horizontal positions there is a great tendency for the filament to drop on to the bulb and to crack it, because of its great length. Furthermore, with the higher voltages the electrostatic attractions are much greater, and, as a result, the filaments tend to approach the bulb.

Broadly speaking, high-voltage lamps may be divided into two classes—double filament lamps and single filament lamps—examples of which are shown in Fig. 85. With the double filament lamps the filaments may be in the same plane or in parallel planes, and in some cases the filaments are shackled to the glass. Shackling, however, possesses two great disadvantages: (1) In consequence of the frequent expansions and contractions, there is the liability of air-leakage being produced, and (2) the shackles may cut the filaments. Of course, with the double filaments there is improved rigidity.

With the single-filament lamps the filaments may be formed into convolutions, or be made wavy, zigzag, or sinuous. To diminish the length, many attempts have been made to use filaments of increased specific resistance or unflashed filaments; but flashed filaments are preferred, in consequence of their longer life, and, so far, the zigzag form gives the best results.

**The Distribution of Light.**—The amount of light received by a body per unit of area is known as the "illumination," or the intensity of incident light; and, generally, the illumination may be taken as being inversely proportional to the square of the distance from the illuminating body. For purposes of reference, 2 units of illumination have been used—i.e., the candle-foot and the carcel-mètre. The candle-foot is the intensity of illumination of 1c.p. at 1ft., or 4c.p. at 2ft., and generally illumination is proportional to illuminating power, and inversely as the square of the distance.

$$\therefore \text{Illumination} = \frac{\text{c.p.}}{(\text{feet})^2}$$

One carcel-mètre is the amount of illumination

of one carcel at a distance of one mètre, and one carcel-mètre = 0.833 candle-foot. The illumination of a horizontal plane varies as the cube of the cosine of the angle of incidence. The candle-foot is a comfortable illumination for reading purposes, whilst about half of this is suitable for ordinary purposes. But the requisite illumination of a room depends upon the character of the interior surfaces and the dimensions of the room. Dark walls require more illumination than highly diffusive wall surface to produce the same general degree of illumination. According to Dr. Sumpner, dull walls only reflect about 20 per cent. of the light incident upon them, whilst ordinary tints reflect 40 to 50 per cent., clean white surfaces 80 per cent., ordinary mirrors 80 per cent., and very good mirrors 90 per cent. Hence, well-whitened rooms require only one-fifth of the light required with dull walls. The height of the room also has to be taken into account, and it is found that one-third candle-power to the square foot of floor space amply illuminates a room for reading purposes. This is equivalent to one 16c.p. lamp for every 50sq.ft. of floor space; and a useful rule is to place 16c.p. lamps 8ft. high, in which they light a circle 8ft. in diameter.

**Advantages of Incandescent Electric-Lighting.**—

- (1) Glow-lamps are capable of affording a uniform character of illumination free from sharply-marked regions of light and shade, since the light can be readily divided.
- (2) They are capable of affording an agreeable and steady illumination, entirely free from disagreeable flickering.
- (3) They are free from noxious fumes, and produce less heating than would an equal amount of gas or oil light. One 16c.p. gas-burner vitiates the air to about the same extent as 12 adult persons; one 16c.p. glow-lamp does not vitiate any air, and gives only one-fifth of the amount of heat produced by a 16c.p. gas-jet.
- (4) Glow-lamps are much safer than a naked gas-flame, since it is placed in a closed chamber, and does not require to be lighted by matches. In the event of a fracture of the glass chamber, the globe is collapsed, and not exploded.

(To be continued.)

A large gang of men have commenced the enlargement of the Rhyl Railway Station. Six new sets of rails have been laid on the Vale-road side of the station for the goods traffic. This is also the site of the new goods offices. The Vale-road bridge will be considerably lengthened. The Holyhead platform will be transformed into an island platform, and the present goods sidings will be used for passenger trains. A new exit has been made on the Chester platform.

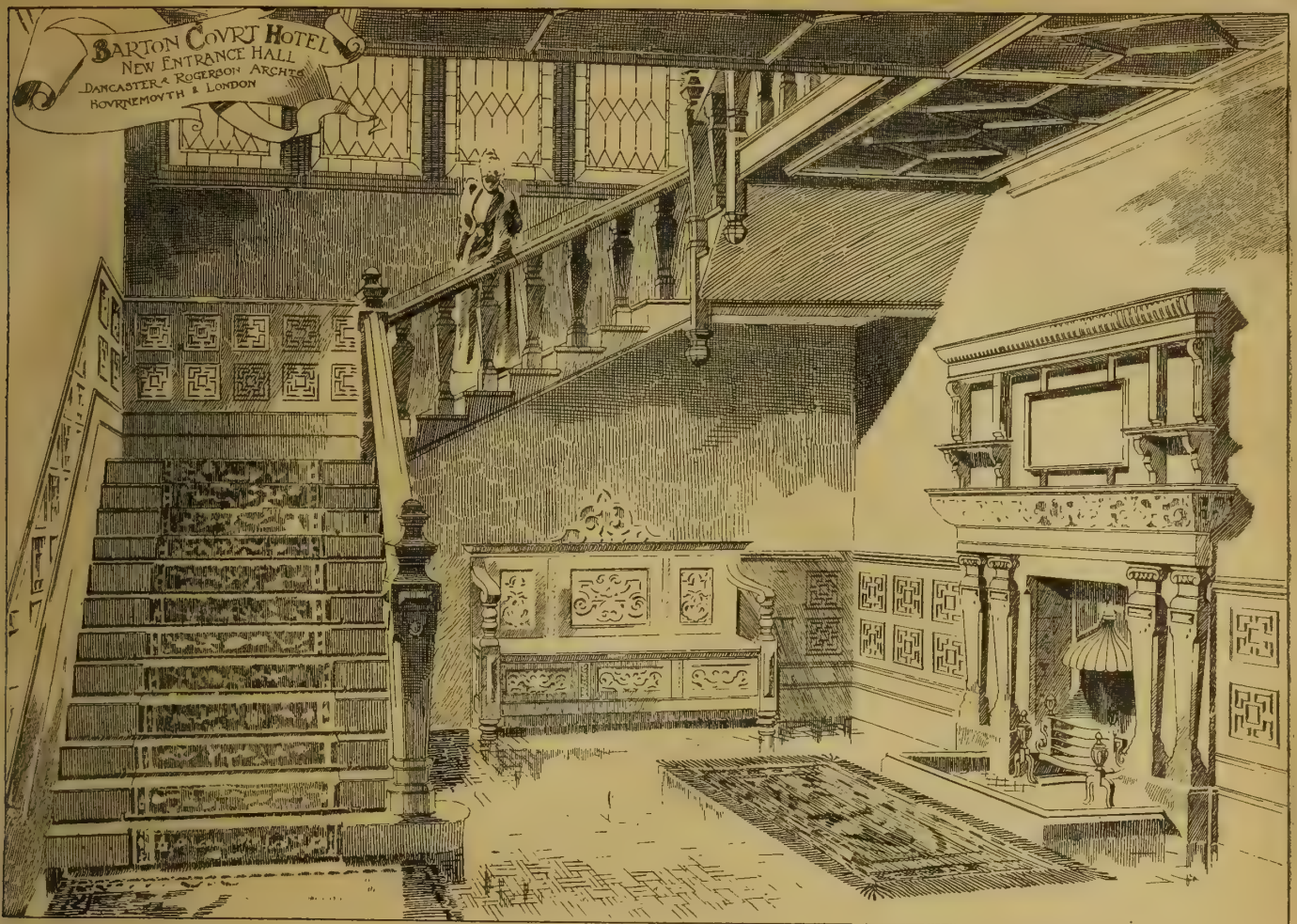

NEW ENTRANCE HALL, BARTON COURT HOTEL, NEW MILTON, HANTS.

THE staircase hall of the new wing to the above hotel, of which we now publish an illustration, will be built at the west end of the present building. We illustrated the new dining-hall of the hotel in an issue of April 29. It having been thought desirable to introduce fire-proof material for the stairs, it has been decided to construct the steps of patent Victoria stone, which will be well bedded into walls and supported by steel girders. The massive moulded and carved newels and balusters will be of solid oak, well dowelled and secured to the Victoria-stone steps. The windows for the entire height will be the full width of the staircase, and filled in with Messrs. Seward and Co.'s lead lights and tinted cathedral glass to design. The chimney-piece and overmantel, which has been specially designed by the architect, will be of carved black oak. The ceiling will have moulded ribs set out in pattern. The architects are Messrs. Dancaster and Rogerson, of Bournemouth and London.

ROYAL ARCHITECTURAL MUSEUM.

THE annual general meeting of the supporters of the Royal Architectural Museum and Westminster School of Art was held in the hall of the Museum, Tufton-street, Dean's-yard, S.W., on Friday afternoon, the chair being occupied by the Duke of Westminster, K.G., President of the institution. The hon. secretary, Mr. Maurice B. Adams, produced a number of letters from persons unable to be present, including one from Dean Bradley, who excused his attendance owing to the fact that he had arranged to conduct a party of workmen over the Abbey at the same time as the meeting in Tufton-street was in progress. Mr. Alfred Waterhouse, R.A., who had promised to be present, telegraphed his apologies for not coming, being prevented at the last moment. Sir Arthur Blomfield, A.R.A., proposed the re-election of the Duke of Westminster, K.G., as President, and the following noblemen and gentlemen as vice-presidents:—The Duke of Norfolk, the Duke of Rutland, the Marquess of Ripon, the Marquess of Bute, Earl Fortescue, the Earl of Wemyss, Lord

Grimthorpe, Sir H. W. Peek, and Mr. Walter Carew Cocks.

Sir Arthur Blomfield alluded to the continued prosperity of the Institution, and warmly referred to the success and usefulness of its work and classes. Mr. J. Hungerford Pollen, in seconding the motion, enlarged upon the change of taste observable in contemporary building as compared with the in-some-ways sterner productions of the Gothic Revival, with which the founding of the museum was so intimately associated. Mr. Pollen referred to the personal interest always displayed by the Duke of Westminster in furthering Gothic architecture, and indicated the fact of Eaton Hall being designed in that manner, as an instance of the application of the Mediaeval style to modern uses practically and cleverly realised.

In returning thanks, the chairman said he feared there was some truth in Mr. Pollen's complaint that London was being spoiled by a jumble of architectural fashions, due, perhaps, to the modern tendency to eclecticism. He had not been guiltless in this respect; but, according to his lights, he had endeavoured to retain something of the grand old style in some of the houses he had caused to be built for himself. It was true that London smoke ruined everything, though good red brick and stone, after all, proved the best material available; but even the smoke did not justify the use of cement, which was now too frequently employed, with its periodical paintings, and which, of all architectural abominations, was the worst. With regard to the rebuilding which had of late years been carried on more closely under his control in the West of London, the Duke ventured, he said, to assert that whatever faults might be named as belonging to the façades thus put up, they were, at any rate, a vast improvement upon what was there before, and, as an example, the rebuilding of Mount-street, Grosvenor-square, was mentioned as being picturesque, and far brighter than the dismal old fronts which not long ago disfigured that thoroughfare.

The report of the council was read by Mr. Francis Ford, Curator. It referred with regret to the loss the museum has sustained by the death of three of the oldest subscribers—Lord Leighton, Mr. J. L. Pearson, and Sir Thomas Dyke Acland. The earnest and enthusiastic

band of men who, in their love for Gothic architecture in its best and purest forms, founded and maintained the museum in its earlier years, is indeed fast diminishing, and at present there is no sign of the ranks being filled up either by members of the architectural profession, or by the general public. The council, however, are confident that the superb collection of examples committed to their charge, and preserved intact for nearly half a century, will, in course of time, meet with renewed appreciation and pecuniary support. During the past year it has been found possible to make, at a very considerable outlay, an addition to the accommodation required for the School of Art, and incidentally to free the central hall of the Museum from studies which were to some extent out of harmony with their surroundings. The new buildings have been completed and partially occupied, and are now being equipped and fitted with the electric light. Four classrooms have thus been added to the accommodation devoted to the school. At last year's examinations, in the most advanced subject of all—viz., drawing from the life, 61 candidates were presented from this school, of whom 22 obtained second-class certificates, 29 first-class certificates, and 8 "excellent" (the highest award), there being only 2 failures. The contract for the new classrooms, which have been built by Messrs. Lathey Bros., from the designs of Messrs. Lee and Pain, architects, was £2,322, and the extras were so few that this amount has only been exceeded by £21 0s. 8d., bringing the total to £2,343 0s. 8d. The building is heated by hot-water apparatus, fitted by Messrs. Haden and Sons, at a cost of £219 14s. 4d. The installation of the electric light will involve an outlay of about £50, and other expenses connected with the building, compensation for disturbance, &c., amount to about £25. The architects' fees amount to £166 6s.; but Messrs. Lee and Pain have generously returned £66 as a donation towards the cost of the building, for the equipment of which the Technical Education Board of the London County Council has voted £250. The total expenditure on the new building, including consequent work in the removing and rehanging of casts in the museum, is thus brought to a total of about £2,850, of which, up to the present date, about £2,600 has been paid. The favourable

condition of the finances is mainly due to the success of the School of Art, which thus repays in its prosperity the expenditure necessary to its maintenance during its earlier days, when it owed its establishment and existence to the fostering care of the museum.

The adoption of the report was moved by Mr. Aston Webb, F.S.A., who reported that it was of an exceptionally satisfactory character. The help afforded by subscribers, £466, was so small relatively, that the institution might be regarded as practically self-supporting; at the same time, the council would be very glad to receive additions to the very small list of subscribers, not only as affording greater means of usefulness, but as evincing wider sympathy in their aims. The new classrooms were well arranged and excellently lighted, and he trusted that the small balance of £250 needed to defray the cost would be forthcoming during the ensuing year; and it should not be forgotten that the capital of the institution had been reduced to meet a portion of the outlay. A feature of the institution was that painters and sculptors had the opportunity of seeing the magnificent collection of architectural casts, and he felt glad that the students had these beautiful examples of past art ever before them. He had suggested that occasional lectures might be given in that hall on the collection, so as to awaken fresh interest in these treasures.

Mr. J. P. Seddon, Chairman of the School of Art Committee, seconded the motion, remarking that he felt that the unique collection of casts in that hall were not sufficiently appreciated by the present generation. He had recently been requested by the council to make a valuation of the casts for purposes of insurance, and found it difficult to put a sufficiently low estimate upon them. Were they destroyed, it would be impossible to replace them in most cases, and the loss to architects would be irreparable, for here the choicest carvings were brought together, and could be compared and studied in a better light and at closer quarters than was possible in the case of the originals. It was to be wished that architects having charge of historic buildings would follow the example of the late Sir Gilbert Scott, and have casts made of typical features as opportunities afforded. During the last decade they had had no additions to their collections.

The report was adopted unanimously.

Mr. C. Forster Hayward, F.S.A., moved the re-election of the council as follows:—Earl Wemyss and Walter Carew Cocks, vice-presidents; and Messrs. C. F. Hayward, Sydney W. Lee, William Pain, J. Hungerford Pollen, J. P. Seddon, and Aston Webb, and Messrs. L. H. Hayter, W. R. Lethaby, and Dr. Garnett, the three last-named being the representatives of the London County Council. He also proposed the re-election of Mr. E. L. Somers-Cocks as hon. treasurer, and Messrs. W. Pain and P. D. Leake as auditors. This was seconded by Mr. Lee and carried unanimously; and a vote of thanks to the Duke of Westminster for occupying the chair, proposed by Mr. Pain, closed the proceedings, after which an inspection was made of the new classrooms.

#### IRONWORK AT SOUTH KENSINGTON MUSEUM.—VI.

By G. A. T. MIDDLETON.

VII.—ENGLISH: TWO SEVENTEENTH-CENTURY TRIVETS.

EXCEPT to draw attention to the effectiveness of their simple design, executed without apparent attempt at mechanical precision, there is little to say about these trivets. The top is the only enriched portion of either—and that is of pierced metal—the ornament in one instance being in the form of a debased anthemion, and in the other consisting of the date.

#### DECORATION OF FURNITURE AND WOODENWARE.

L. G. ANDES gives, in the *Zeitschrift für Drechsler*, some directions on this subject. In order to produce coloured decorations on wood, the wooden plates are treated with hydrochloric acid, which renders the surface of the wood porous. The figures are then pressed in with an engraved plate and strong pressure, and the whole plate is polished off smooth with pumice stone. When the wooden surface is subsequently coated with a colour solution, a handsome design

will result, because the pressed and denser places take up less colour, thus showing a lighter tone of the same colour than the places not pressed.

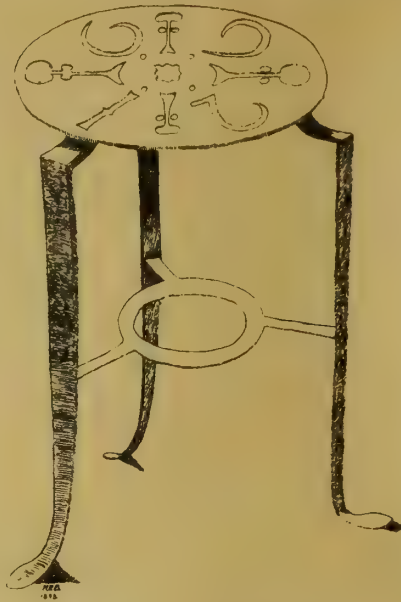

WROUGHT-IRON TRIVET, 1692.



TRIVET, ENGLISH, 1668.

(Brass Open Work on Iron Stand.)

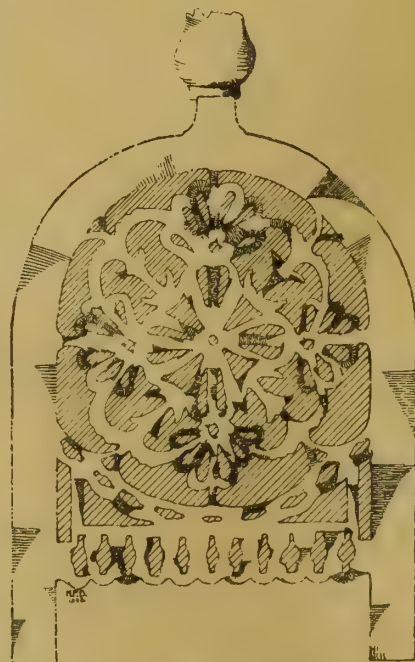

Top of Brass Open Work.

For preserving varnished and stained woodenware, the following process is recommended: The lye, prepared from 3 parts potash, 1 part calcined tartar, and 24 parts water, and thinned with 48

parts water, is spread out uniformly to prevent the formation of spots. After three to four minutes' action, the lye will have dissolved the dirt, and rinsing off with water should follow. It is also advisable to clean varnished articles with olive-oil. Flour, hair-powder, or prepared white hartshorn is dusted on the applied olive-oil, and the olive-oil is rubbed off again with a soft rag. By this means not only the dust and spots are removed, but the gloss of the furniture is restored at the same time.

The following process is said to be well adapted for the production of black, faintly lustrous polished surfaces:—Plane the surface smooth and clean it nicely, stain with a strong decoction of logwood chips, and after this coating is half dry, finish staining with iron liquor (iron pyrolignite); allow the resulting black colouring to dry well, and rub down the raised grain carefully. If light places appear in consequence of the rubbing, stain them black again. After the last rubbing with pumicestone and oil, polish the surface with pale shellac polish in which some aniline black has been dissolved, or dissolve the aniline black in the alcohol necessary for rubbing down, and finish colouring in this manner. When the polished surface has become dry, rub it down with burnt pumicestone and water, using a piece of hat felt, remove the mass entirely, and give the surface a dull lustre by treatment with wax salve.

#### DISTRICT SURVEYORS' ASSOCIATION DINNER.

THE district surveyors of London dined together at the Café Royal, Regent-street, on Tuesday, the 14th inst. The chair was taken by Mr. Horace Gundry, F.R.I.B.A., the president, and he was supported by the members of the tribunal of appeal, Mr. Arthur Cates, Mr. A. A. Hudson, and Mr. G. W. Penfold, two members of the L.C.C., Mr. R. A. Robinson and Mr. H. A. Harben, while Parliament was represented by Sir George Fardell, M.P. Other visitors were Mr. J. Hebb, Mr. G. W. Thomas, and Mr. J. W. Godfrey, who attended with their chief, Mr. Thos. Blashill, superintending architect, and Mr. B. Hayward, son of Mr. C. F. Hayward. The R.I.B.A. was represented by Mr. W. Emerson, hon. sec., and the law by Mr. T. Wheeler, Q.C., and Mr. A. Collins, and Mr. J. Andrews was the guest of the vice-president. The following district surveyors were present:—Messrs. L. Tabberer, V.P., H. H. Collins, C. F. Hayward, F. Wallen, G. Elkington, A. W. Tanner, E. Marsland, W. H. Lees, R. P. Motley, Alex. Payne, A. Conder, Walter Spiers, H. Cheston, H. W. Stock, Henry Lovegrove, A. Williams, Geo. McDonell, E. Carritt, and A. Crow. The usual toasts were honoured, and the musical arrangements were under the direction of Mr. G. F. Smith, of Brixton. The toast of "The Houses of Parliament" was proposed by the President, and was responded to by Sir Geo. Fardell, M.P. "The London County Council," by Mr. C. Forster Hayward, responded to by Messrs. Harben and Robinson. "The District Surveyors' Association," by Mr. A. A. Hudson, responded to by Mr. Horace Gundry, President. "The Tribunal of Appeal," by Mr. H. H. Collins, responded to by Mr. A. Cates. "The Officers of the County Council," by Mr. T. Wheeler, Q.C., responded to by Mr. T. Blashill. "The Vice-President and Officers," by Mr. G. Elkington, responded to by Mr. Tabberer. "The Visitors," by Mr. H. Lovegrove, responded to by Mr. W. Emerson.

#### COST OF PILE-DRIVING WITH THE STEAM-HAMMER.\*

MANY formulas have been given at various times, by experts, to determine the cost of driving piles with the drop-hammer, under various conditions and into different soils, but experience has proved them to be very unreliable. This being the case with an old and universally used machine, it must be considered a problem of the future to suggest formulas for the cost of driving piles with the steam-hammer. While the writer does not claim that the steam-hammer will drive piles more cheaply under all conditions than will a drop-hammer, still where the two have been operated at the same time

\* A paper by E. N. PAGESEN read before the Engineering Association of the South (U.S.A.) and published in the *Papers of the Association*.

under similar conditions the former has been the more economical. No cases to the contrary have been reported where the modern machine has been used. Its greater first cost is of course a large factor to be considered, and often prohibits its use where it otherwise would be selected. A very good example of the work of the two kinds of machines is that done in the driving of piles for the foundation of a large gas-holder in New York City. With a 2,500lb. drop-hammer, four piles were all that could be driven in a day of ten hours, while a steam-hammer drove thirteen. They were each 70ft. long, 8in. in diameter at the point, and 15in. at the head. A total of 800 were driven, at a cost of two dollars each. In New York Harbour the drop-hammer drove fifteen piles per day of ten hours, often breaking or otherwise damaging them, while the steam-hammer averaged from 40 to 45 without damage. The piles were 50ft. long, driven 24ft. to 26ft. into gravel and hard-pan. A total of 1,800 were driven, at a cost of 80 cents each. In Puget Sound the steam-hammer averaged nearly 200 piles per day where the drop-hammer could not put in over one-fifth that number, and even then many were damaged. The same crew did the work with both. These piles are 100ft. long, of Oregon fir, measuring but 6in. in diameter at the point, and are driven butt end down for strength. They are used in the fishing industry. In this case the heavy blow of the drop-hammer caused the pile to spring sidewise, often to split, while the many lighter blows of the steam-hammer jarred the piles down. In the following cases no comparison can be made directly, but engineers can recall instances in their own experience which may be used. In Chicago, 40 Norway pine piles were driven 45ft. deep every ten hours at a cost of 55 cents each. Another firm drove from 60 to 65 piles, each 45ft. long, 15ft. deep into hard sand each day at a cost of about 80 cents each. In both cases they were driven for foundations. A New Orleans firm reports the cost of driving 6,000 piles for wharf construction with a floating driver during three months as follows:—

	Aug.	Sept.	Oct.
Average number per hour .....	3.05	4.34	3.7
Average length per pile in feet .....	70	65	73
Average cost per pile-driving in dollars.	1.70	1.14	1.23

The same firm used the same hammer for driving bents for a railroad trestle. The driver moved forward on the bents as fast as they were capped. The rate was 11 bents per day, piles varying from 20ft. to 45ft., and driven 15ft. deep. Total number of bents was 141, and four piles to a bent were driven at an average cost of 85 cents each. The hammer moved in pendulum leaders, driving the piles at quite an angle. The hammers used in the above cases were made by a local firm, and, with one exception, were of the following dimensions:—Total weight, 9,000lb.; weight of striking ram, 4,800lb.; stroke, 42in., and about 60 blows per minute; the coal consumption is about 2,500lb. per ten hours. The engineer can do his own firing. The crew needed is the same as for a drop-hammer. The hammer used on Puget Sound was somewhat lighter:—Total weight, 6,100lb.; weight of ram, 3,000lb.; stroke, 30in., and about 70 blows per minute. The parties using this hammer claim that the blows are somewhat too heavy for the long piles, and advise a lighter and much faster hammer. It seems that in this case in particular, the short interval between the blows does not give the soil time to settle around the pile, which is prime advantage in using the steam-hammer.

BOOKS RECEIVED.

*Party Structure*, by SYDNEY PERKS, A.R.I.B.A., &c. (London: The St. Bride's Press, Ltd., Bride-lane, Fleet-street) is a useful little epitome of Part VIII. of the London Building Act, 1894, in which the author deals with various questions and decisions under this part of the Act. Mr. Perks points out important differences between the old and new Act. The building owner has now power to underpin (sections 88, 1, and 6). The case of "The Standard Bank of South Africa v. Stokes" establishes this right. He has also power to cut away other projections besides chimney breasts, jamba, or flues from external as well as party-walls, a right to raise a party fence wall, or pull down and rebuild it as a party-wall (sub-section 12). In the old Act no mention was made of a fence wall. There are, however, restrictions as to time, proper notice (14 days), consent of owners and occupiers, shoring up, and hoarding (section 90). The adjoining owner has to pay a

proportion of the cost of raising or underpinning walls if he uses them. Several leading cases are referred to, as "Weston v. Arnold," "Knight v. Pursell," "Drury v. Army and Navy Stores," a recent and important decision, in which it was held there was no presumption that a wall which was a party-wall as to a portion of its height, should be a party-wall as to its whole height. Referring to this last case, Mr. Perks remarks that those who framed the Act did not contemplate openings in ordinary or technical party-walls. The Act is perfect under the supposition that there was no intention to allow openings, not otherwise. The author says the majority of district surveyors would not accept this case as conclusive. The reasoning seems sound by which he establishes this view. Till the decision has been reviewed by the High Court it is likely surveyors will abide by it, however unsatisfactory. Many other important points are discussed, as the mode of procedure in party-structure cases. The author mentions objections to the form of the R.I.B.A. notice which appear sound. Sect. 88, as to building owners' rights of raising and underpinning external walls and party-walls and other sections are commented on. The text of the Act and schedules are given.—*Manual Training Woodwork*, a handbook for teachers, by GEORGE RICKS, B.Sc.Lond., Inspector of Schools, &c. (London: Macmillan and Co., Ltd.), embodies the results of experience in the training of hand and eye in the working in wood with carpenter's tools. The book has been written for teachers. Mr. Ricks enumerates certain principles in the attainment of this object: (a) Drawing is made the fundamental basis and integral part of the whole scheme, and working drawings to scale is made for every piece of work. Every piece of wood must be lined-out before being cut. (b) The material selected must be such as will facilitate neat and accurate workmanship, and suitable tools be used. (c) The pupil must acquire an intelligent knowledge of the various woods he works on, and of his tools. (d) The exercises must excite interest, and be carefully graduated, proceeding by easy steps from the simple to the complex. The principles of projection or the drawing of plans, elevations, and sections, is first dealt with, and illustrated by large and clear diagrams, which will easily be understood by teachers and pupils. These are all drawn to scale. The subject of planes as illustrating the making of plan and elevation is popularly explained; after which rectangular prisms—as cubes—are given as another exercise. These are built up to form an object. Cardboard or thin batten is the material suggested. To assist the pupil's eye in the instruction, isometric projection is used, and this mode of drawing solid objects is explained by simple diagrams. The chapter on timber and its structure is well illustrated by sections of different kinds of timber, and the processes of seasoning and shrinkage are clearly described. Next, tools and other appliances are enumerated and illustrated. The graduated exercises are well selected, and are arranged to avoid waste of material. Very simple exercises like cutting a certain size piece of board; setting-out, sawing, and planing a prism; chamfering it; horizontal chiselling of different kinds, from simple to oblique; sawing and planing-up geometrical figures, and parquetry work lead up to exercises of a more complex and constructive kind—making boxes in which "housing" and nailing are required, half-lap joints, mortising and tenoning, dovetailing, and other kinds of jointing. Carved work and mouldings come into these more advanced exercises. As a useful manual for the teacher of our technical and board schools, we can recommend this handbook.—*The Present Position of the Sewage Purification Problem*, by H. GILBERT WHYATT, Assoc.M.Inst.C.E., &c., Deputy Borough Engineer, Salford (London: The Westminster Press, Regency-square, S.W.), is a small brochure dealing with this question. The author discusses the position taken up by the Local Government Board, the discoveries of late years as to the purification of sewage by means of micro-organisms in bacterial filters, and, lastly, the description of the more noted of these systems. Mr. Whyatt speaks of the Salford experiments on purification, which have been carried on for ten years, much time having been spent upon various patented chemical processes, but all failures. Five years ago Mr. Joseph Corbett, the borough engineer, proposed artificial filters, and experiments were made. A set of six filters were arranged at three heights, with a

ventilation floor between each of 20in. of filtering material: two were composed of gravel and sand, two of coke breeze, and two of cinders; the cinders proved the best filtering media. The results were good. The advantages of a preliminary "roughing" filter were proved. The filters were altered to have two, three, or four stories, and thus have different degrees of ventilation, and this experiment is being continued. A record of the effluents from each filter has been kept, but no practical difference has been found. The use of wooden troughs to deliver the effluent at 2ft. or so above the top has been found more successful than troughs imbedded in the filters. So long as the filters do not choke up by a glutinous mass of bacteria, the quality of the effluent is good; to clear the filter material it is only necessary to leave the filter idle for a week or two to recover its aëration and take the sewage. A week's rest starves the bacterial population out of existence, and the filter recovers its efficiency. We cannot give all the facts; the Salford Corporation consider the system so satisfactory that they have resolved to spend £80,000 in laying down bacterial filters; but the Local Government Board have refused to sanction the expenditure unless the Corporation include a sum to cover the purchase of a sufficient quantity of land over which the filter effluent may be turned. The author says the time has arrived when the Local Government Board should be aroused from its agnostical state and undertake an examination of bacterial filters which have proved so successful. Wimbledon, Wolverhampton, Yeovil, Lichfield, Buxton, Leeds, Oldham, and Manchester have all tried experiments, and, according to the author, the results have been satisfactory. We recommend all authorities and borough engineers to peruse this little book.—We have received from Sir John Leng and Co., Dundee, the attractive Summer Number of the *People's Journal*, which contains much that will interest holiday readers, including nine well-written stories, and the usual prize letters, essays, and sketches.—*St. Martin's Church, Canterbury*.—This is the first of a set of books on well-known churches, published by Messrs. George Bell and Co., London, uniform in size and style of ornamental cloth binding, with their excellent Cathedral Series, of which we have reviewed the eleven volumes already published. The Church series are, however, to be navy blue instead of pea-green in colour. No parochial building of greater historic interest exists than St. Martin's, Canterbury, and the publishers have secured a well-qualified guide to pen its story in Canon Routledge, who mentions in his preface that during recent explorations so much fresh matter has been brought to light that it has become almost necessary to re-write the structural description of the building, and to reconsider the date of its erection. The author gives structural evidence to justify his guarded belief that it is "more than probable" that parts of the original structure mentioned by Bede are standing, and that the present walls were not only consecrated by the memory of St. Augustine, but may be traced back to a considerably earlier period. The little monograph, which is clearly and brightly written, is illustrated by plans and some four-and-twenty engravings, several of these showing the early work recently discovered in the church.—*Smith's Law of Master and Servant* (London: Effingham Wilson). A new edition of this well-known handbook on the legal relations between employer and employed, edited by Mr. G. F. EMERY, LL.B., barrister, has just been published. It contains a new chapter dealing with the Workmen's Compensation Act, 1897, which comes into operation, as our readers are aware, on Friday, the first of next month; but some necessary corrections have been made in the text of the earlier portion of the work. An appendix deals with the Conciliation Act of 1896.—*Calculation in Hydraulic Engineering*.—A practical textbook for the use of students, &c., by T. CLAXTON FIDLER, M.Inst.C.E., Professor of Engineering. Part I. (London: Longmans, Green, and Co.) ought to be a very useful handbook for engineers, students, assistants, and draughtsmen engaged in making hydraulic calculations in connection with engineering works of this kind. Mr. Claxton Fidler does not pretend to write a treatise on hydraulics, but rather to apply principles; and his introductory remarks on fluid pressure in Chapter I. are clear, and will much simplify the conception of such pressure as the engineer understands it—such, for example, as the practical exemplification that

the engineer is more likely to understand the theory of fluid pressure, if applied to a square box filled with high-pressure steam or fluid, which acts upon each side of the box at right angles to the plane of boundary, or to the bottom and lid, and to each side of box, than if he were informed in the language of theory that the pressure acts equally in all directions at any point in the internal mass of the fluid. The articles on fluid pressure of uniform intensity are explicitly penned. As regards fluids, we are reminded that they have weight, and so it is not true to say a fluid pressure is of uniform intensity, but for practical purposes it may be assumed to be uniform. Thus if a cubical box be charged with water under a pressure, the pressure downwards will be greater than that upwards by the weight of the water, or 62½ lb. if the box measures 12 in. on each side. But in practice this weight is not worth considering. The chapter on cylinders, pipes, bends under uniform pressure, is an important one for engineers, as it considers the effect of unbalanced internal forces in pipes with bends, and the axial stress caused by the fluid, the transverse strength of pipes, the buckling of straight pipes, the strength of joints necessary, expansion joints, hydrostatic pressure, floating vessels, &c., are discussed in terms of simple mathematics. Such practical questions as the pressure upon vertical walls of irregular figure, and upon inclined and curved surfaces like walls are considered, and the examples, with practical calculations, are very useful.

#### CHIPS.

The Prince of Wales will lay on Saturday, July 2, the foundation-stone of new buildings in Creek-road Deptford.

The new Metropolitan Tabernacle is to be rebuilt on almost the same plan as the burnt church; but the upper gallery will be omitted and the exits widened.

Ornithology and entomology have sustained a great loss by the death of Mr. Osbert Salvin, F.R.S., which occurred last week at his residence, Hawkfold, near Haslemere. He was the second and only surviving son of the late Mr. Anthony Salvin, the well-known architect.

The foundation-stone of a temporary church in Salisbury-road, Redlands, Bristol, was laid last week. The building, which will eventually be used as a parish-hall to the permanent church, will be 108 ft. long and 36 ft. wide, the roof rising to a height of 50 ft. The chancel and sanctuary at the east end are to be approached by a few steps. There will be a porch on the north-west side. The building, which is to be constructed of Pennant stone, will be Gothic in style, the open roof being of pitch pine and covered with Broseley tiles. The builder is Mr. Vowles, of Elton-road, Bristol, and Messrs. P. Munro and Son are the architects.

The Bishop of London has fixed Friday, July 1, for the consecration of the new Church of St. Peter, Hornsey, built from the designs of Messrs. James Brooks and Son. About £2,000 is still required, the total cost of the nave and aisles being nearly £8,000.

The old parish church at Bothwell, N.B., is about to be restored at the cost of some subscribers. The works will include a new organ and case to be placed in the west gallery, and fresh furnishings, comprising communion table and chairs, gas standard and sconces, and also of the chairs, table, press, and brackets for the sacristy. Intimation was also made of a gift of a stained-glass window, representing the Nativity of Christ, for the east end of the church. The sketch has been prepared by Sir Edward Burne Jones, and the work is to be executed by Messrs. William Morris and Co., of London.

The Great Northern and City Railway undertaking, which, on its introduction four years ago, failed to receive any substantial measure of support, is again to be brought before the investing public. The line will run from Finsbury Park to Moorgate-street, and will have intermediate stations at Drayton-park, Essex-road, and Old-street. The share capital is to be £1,560,000, and the directors anticipate that the railway will earn a minimum annual income of £81,500, whereas to pay the debenture interest and preferred dividend only requires £52,000.

The rector of Hawarden, the Rev. Stephen Gladstone, has adopted plans by Mr. J. Douglas, of Chester, for the erection of a district church at Shotton. It is proposed to build a nave with clerestory, a chancel and apse, a north aisle and porch, and to leave the tower and south aisle for others hereafter to complete. The present expenditure is estimated at £3,000.

## Engineering Notes.

**DUNOON.**—The ceremony of opening the new pier has been performed by Lord and Lady Malcolm of Poltalloch. The old pier at Dunoon belonged in former years to the Hafton Trustees, but was purchased by the commissioners for £27,000. The commissioners decided to renovate and extend the structure—a work entered upon two years ago. It was resolved to incorporate the old pier with the new structure, and to utilise the old gangway for goods and luggage traffic, providing a new gangway for passengers. The pier-head is now 440 ft. long by 60 ft. wide, and the new gangway is 170 ft. by 40 ft. The structure is of timber, secured by iron bolts, and sheathed in places with iron plating. The depth of water is 10 ft. at low tide, and 20 ft. at high tide. On the pier waiting-rooms have been erected, while at the shore-end stand the administrative offices, surmounted by a clock-tower. A covered verandah runs the whole length of the waiting-rooms, fronting the sea, and the signal-box is placed at the sea end of the new gangway, with a belfry above, in which a fog-bell has been hung. The pier and rooms will be lit at night with electricity. In addition to the pier, the works include a sea-wall about 300 yards in length, formed of rubble concrete, and surmounted by an iron railing. A new road has also been constructed, at a cost of over £3,000, through the hillock known as Tom-na-bhoird. Mr. W. R. Copland, Glasgow, was the engineer of the undertaking.

**HERNE BAY.**—A Press view of the Pier extension was given on Saturday. The old pier ran out to a length of only 400 ft., and was left at low tide high and dry. It has now been lengthened by the addition of 3,320 ft., making it the longest pier on the Kentish coast, and, as the head is constructed in deep water, steamers will in future be able to land passengers at any state of the tide. In the new structure there are eight alcoves, where the width is 30 ft., and at two points the pier is widened to 66 ft. The pierhead when completed will be 76 ft. wide, and will carry an octagonal pavilion 40 ft. wide. Beyond this there will be an independent timber landing-stage for the steamers. The pier is built on screw piles driven about 10 ft. into the sea bed, the superstructure being of steel, with a wooden deck, which is 14 ft. above the highest water. The total weight of steel and iron used is 1,600 tons. An electric tramway runs the whole length of the structure, which will be completed early in July. The sum expended on the pier has been about £20,000. Mr. E. Matheson is the engineer.

**LANARKSHIRE AND Ayrshire RAILWAY.**—At Lugton, Ayrshire, the Hon. Mrs. Greville Vernon cut recently the first sod of an extension of the Lanarkshire and Ayrshire Railway, which is to connect, by a direct and easy route, the port of Ardrossan with the coal and iron producing districts of Lanarkshire. Ten years ago the first portion of the company's line was opened from Barrmill to Ardrossan, with spur lines to Kilwinning, Saltcoats, and Irvine. This line gave a very much shorter route from Glasgow and Barrhead to the places named than had previously existed, but the trains had all to pass over some fifteen miles of the Kilmarnock Joint Line, including the very steep gradient of 1 ft. in 67 ft., continuing for nearly three miles, between Barrhead and Lugton. The extension now entered upon will avoid this gradient, and will also obviate the delays at present incurred by having to take the traffic over the congested lines in the neighbourhood of Glasgow. The new line commences with a junction near Barrmill with the company's present line, and will run into Lanarkshire through Lugton to Neilston and past Barrhead on the south-west on to Cathcart, Cambuslang, and Newton. Spur lines will connect with the Kilmarnock Joint Line at Lugton, and with the Caledonian Company's Busby line. As the steepest gradient on the new line will not be greater than 1 in a 100, every train can be run at full load. The railways comprised in the company's whole scheme are eleven in number, but several are merely loop or branch lines. In the aggregate they are 26 miles in length. The engineer of the line is Mr. Charles Forman (of Messrs. Formans and McCall), and the contractors are Messrs. R. M'Alpine and Sons, who executed the earlier portions of the Company's undertakings.

**LUMLEY CASTLE.**—The Earl of Scarborough

having decided to erect a bridge across the River Wear adjoining the existing ferry at Lumley Castle, instructed Messrs. D. Balfour and Son, civil engineers, of Newcastle, to prepare plans for a suitable structure, the contract for which has been let to Messrs. Head, Wrightson, and Co., of Stockton-on-Tees, who expect to start the work this month. The structure consists of a centre span of 120 ft. and two side spans, each 37 ft. long. The main and approach girders are to be of mild steel lattice-work, the bottom flanges being wind-braced, and the top flanges supported with struts and overhead arches. The flooring will consist of creosoted timber, with water-boards at each side. The piers will be each composed of four braced wrought-iron piles, formed of four segments riveted together, having cast-iron pile points, and driven 21 ft. below river bed. Gates and turnstiles are to be fixed at end of bridge, and lighting arrangements to be provided. The structure is calculated to stand a safe distributed live load of 140 lb. to the square foot, with four times this amount for the ultimate load.

**WATERLOO AND CITY RAILWAY.**—The opening of this underground electric railway will take place in the first week of July. The line is carried in two iron-bound tunnels, which have, as far as possible, been excavated under the public thoroughfares, and at one point only—near Stamford-street, Blackfriars—has it been necessary to make any arrangement with the owners of private property. The only stations are the terminal ones at Waterloo and at Bucklersbury. The platform of the Waterloo terminus, laid at a depth of 41 ft. immediately underneath the principal main lines of the London and South-Western Railway, is approached by a series of inclined ways. After a sharp curve into York-road, the underground tunnels, rapidly descending, cross Waterloo Bridge-road, and follow the route of Stamford-street as far as Hatfield-street, where they turn in a north-easterly direction. Penetrating the bed of the Thames, they emerge on the Middlesex side of the river, in front of the Royal Hotel, and proceed under the centre of Queen Victoria-street to the City terminal station, which will eventually have an entrance to the public subway now in course of construction under the crossing in front of the Mansion House, the Royal Exchange, and the Bank of England. For the first, the City approach will be by two staircases near the premises of the National Safe Deposit Company in Queen Victoria-street. The railway works have been carried out by Messrs. Mowlem and Co., the engineers at the outset being Mr. W. R. Galbraith, M.I.C.E., and Mr. J. H. Greathead, M.I.C.E.; Mr. Harley H. Dalrymple-Hay, A.M.I.C.E., acting as resident engineer. Mr. Greathead died before the completion of the contract, and his place has since been taken by Professor A. B. W. Kennedy. Much of the tunnelling was executed in compressed air-locks, owing to the fact that the deep excavation had to be continued through a strata of water-bearing gravel. Where compressed air had not to be employed, the ordinary rate of progress was about 10 ft. per day of completed work. The smallest diameter of the tunnels is 12 ft. 2 in. Electrical power is supplied from a generating station built close to the Waterloo end of the line. Therein are erected five boilers, engines, and dynamos, each of about 300 H.P., and an evaporative condenser. The line is laid on the central conductor principle, the conductor being a channel-shaped steel rail, receiving an electric pressure of 500 volts. Five trains have already been ordered from the Jackson and Sharp Company, of Rochester, U.S., but six will be required to maintain the frequent service proposed. Each train consists of four coaches, the first and last being motor-cars. The ordinary carriages will seat 56 passengers, and the motor-coaches 46, the seating capacity of each train being for 204 passengers. Professor Kennedy has designed the electrical arrangements, and Messrs. Siemens Brothers and Co. have been the contractors for this part of the work, including the motors in the carriages.

The partnership heretofore subsisting between G. F. Lambert and J. C. Rees, of Neath and Bridgend, architects, under the style of Lambert and Rees, has been dissolved.

The Board of Trade has issued a provisional order to the urban district council of Barnes empowering them to supply electricity throughout the whole area within their jurisdiction, but excluding Hammersmith Bridge.



## Building Intelligence.

**BOURNEMOUTH.**—The new chancel of the Bennett memorial church of St. Stephen was formally dedicated by the Bishop of Guildford on Friday. The whole interior of the church, which is Early English in style, is of Bath stone, with groined stone ceiling, and clustered columns and lofty arches of varying span. The new chancel is of apsidal shape, forming a pentagon, and north and south transepts, a choir, two vestries, and a small circular apsidal Lady-chapel on the north side have also been added, together with a stone organ-loft in the south transept. The apse is carried up on eight lofty columns which rise to the groining, and are tied at their centres and capitals to the outer wall by shorter arches, the lower ones being surmounted by a quatrefoiled parapet of pierced stonework. The intervening spaces between the bases of the columns and the outer wall form an ambulatory which is continued round the back of the altar. Each bay of the apsidal chancel has a lofty three-light clerestory window, the centre one being of stained glass. The diagonal ribs of the groinwork which terminate in a central ornamented boss or key-stone and those of the transepts and chapel are treated with dog-tooth moulding. The sedilia, credence, and piscina form one design, and occupy the three south bays of the chancel. The reredos in the chancel is of red marble, and that in the Lady-chapel of alabaster. The reredos, which is of carved woodwork, takes the form of a triptych, the central subject being the Crucifixion, the wings containing figures of saints and angels, all carved in high relief and coloured and gilded. The length of the chancel and sanctuary from the nave is 50ft., and the length of the two transepts is 75ft. by 16ft. in width. The height from the floor to the groining of roof is 50ft. The first contract for the additions, which have just been completed, was about £10,000, but the extra work has reached an additional £2,000. Altogether, when completed, the church will have cost about £30,000. The builders are Messrs. Abbey and Co., of Salisbury. The architect of the first portion of the work was the late Mr. J. L. Pearson, R.A., and since his death his son, Mr. F. L. Pearson, has acted as architect. The foreman has been Mr. F. Chalk, and the clerk of the works, Mr. W. Harlow. The chancel and transepts are lighted by electricity, and it is intended to use the electric light in the nave at a later date. There have been many gifts to the church, including a carved oak altar-table made by Messrs. Drake, Limited, Bournemouth. The alabaster and marble reredos are the work of Mr. Davidson, of London; the reredos is by Messrs. Moos Bros., of London; the sculptured figures and carving being by Mr. N. Hitch, of Harleyford-road, Vauxhall, S.W.

**BRIDLINGTON.**—The foundation-stone of the Grammar School was laid on Tuesday by Sir Charles Legard. The style is the scholastic type of the English Renaissance. The structure will be of red brick, with stone dressings and red-tiled roofs. The hall occupies the centre, and is 51ft. 6in. by 30ft., rising through the height of the two stories. It has an open-timbered roof, and is surmounted by a turret. On the west and south sides of the hall are four classrooms, which will afford accommodation for a hundred boys. On the north side space is left for additional rooms, which will be provided when funds permit. The principal entrance to the school will be beyond the classrooms on the east front, and the playground entrance will be on the west front. The head-master's house on the south side will have frontages to the east and south. Accommodation is provided for thirty boarders, with dining-hall on the ground floor and dormitories on the first floor. The buildings have been designed by Messrs. Botterill, Son, and Bilson, architects, of Hull, and the erection will be carried out by Messrs. John Thompson and Co., of Peterborough, at a cost of over £8,500. Mr. W. H. Williams is the clerk of works.

**GLASGOW.**—The corner-stone of the new Episcopal church and halls which are in the course of erection in Baltic-street, Bridgeton, Glasgow, was laid on Saturday. The new church, which is being erected to commemorate the thirteenth centenary of St. Columba, and will be named after that saint, is built in the Late Gothic style, and consists of a nave with a chancel and a south aisle. A morning chapel adjoins the chancel, and a mortuary chapel is at the south-

west corner of the site. The large hall will accommodate between 300 and 400 persons, and there is also a smaller one. The total cost will be £4,000.—The special committee on Springburn and Cowlaw halls reported to the town council on Monday that they had met with Messrs. Burnet and T. L. Watson, members of the Institute of Architects, and it had been decided, by modifying the architectural treatment of the halls to some extent, to reduce the cost to £11,000. The new hall is to be erected at the corner of Keppochhill-road and Millarbank-street, and is to be capable of seating 1,200 persons, while a smaller hall is to be capable of accommodating 400 persons. Mr. O'Hare moved that the matter be taken back for the further consideration of two points—that the commission of 5 per cent. to be paid to the architects be reduced to 4 per cent., and that the accommodation be increased. Mr. Chisholm moved that the whole matter be taken back *simpliciter*. When he thought of the sum for which a large and ornate church could be erected, he thought it was ridiculous to spend £11,000 upon such a hall. Mr. W. Paton, in seconding, said the suggested cost was excessive. After some further discussion, Bailie King agreed to Mr. Chisholm's motion, and this became the finding of the council.

**HORNSEA.**—The improvements at Hornsea, inaugurated to commemorate the Diamond Jubilee, are on the eve of completion, and on the 6th July the waterworks new reservoir, aëriator, and filtering beds, the Promenade Gardens, and the Market-place improvement will be inaugurated. Three or four acres of land on the North Cliff have been laid out as pleasure grounds. The adjoining portion of the Lansdowne estate is being laid out as building lots for high-class houses. The view of the parish church has hitherto been impeded by a block of some three or four cottages standing between it and the main street. An opportunity arose for purchasing this obstructive block, and it has now been pulled down, leaving an unrestricted view of the church from all quarters. The total cost has been £560, raised by public subscription and by the grant from the urban council. Thirty years ago there stood in the middle of the Market-place the old cross. A reforming hand ordered its removal, and it was in danger of being broken to pieces when Mr. George Heslop placed it in his garden. It has now been resuscitated, restored, and erected in a prominent position near the church. The waterworks were constructed in 1879 at a cost of £12,000. Owing to the increasing size of the town, it had been inadequate for daily requirements, and the council have therefore spent recently upwards of £2,000 in providing an aëriator, filter-beds, and reservoir, which will insure an abundant supply of water for many years to come. To back up these improvements, the North-Eastern Railway Company have doubled the line in places, and have promised an improved train service during the season. Golf links are being laid out, and will be ready next month.

**LEEDS.**—The corporation of this city are building working-class dwellings on the Camp Field insanitary area. A number of dwellings thereon have to be pulled down, and, in accordance with the Act of Parliament, provision must be made for the displaced tenants. The site selected is Derwent-avenue, Sweet Street-west, Holbeck, and there ten cottages will be erected. Each will have a living-room and scullery, two bedrooms, and an attic, and a cellar. They will be through houses, and each will have its own backyard, w.c., and ashpit. The site of each house—12 yards by 5 yards—has cost £42, the building upon it will entail an expenditure of £180; and the sewerage, kerbing, paving, and flagging will bring the total cost per dwelling up to £233 10s. If the requirements of the Local Government Board are to be complied with, the work cannot be done for less; and, if the corporation is not to lose money by the enterprise, the rent per dwelling must be 5s. 9d. per week, including rates. This will give about 4½ per cent. on the expenditure, sufficient to pay interest and principal in thirty years. Mr. George Carter, of the City Engineers' Department, has prepared the plans for the dwellings.

**MORECAMBE.**—This popular watering-place already possesses a new theatre, winter gardens, two piers, Regent Park and pavilion, and a revolving tower now all but completed. As an addition to these, the latest scheme put forward

takes the form of a massive tower of novel design, and a site has been secured in Calton Lodge and grounds, with an extensive frontage to the promenade between the Central Pier and Emmanuel Church. On a portion of this estate it is proposed to erect a tower 232ft. in height and 130ft. diameter at the base. The tower in general form will be a cone gradually diminishing in diameter, and having four floors above the ground level. The first of these floors will be 70ft. above ground, the second 102ft., the third 132ft., and the fourth 157ft., with a turret reaching to a total height of 232ft. A road track with an electric railway under it will wind round the outside of the eight principal pillars in spiral form. This roadway is to be supported on the inside edge by a girder at the same level, and on the outside edge by pillars from the girder of the stage below. The structural steel work of the tower is calculated to support a strain of 1,000 tons on every portion accessible to the public, in addition to its own weight, and a wind stress of 56lb. to the square foot over its whole surface. The weight of the constructive steelwork of the tower is estimated at about 862 tons. The top gallery will be readily reached by pedestrians, the winding roadway—800 yards in length—being of no greater gradient than 1 in 10. In the sides of the tower from the base to the summit a series of alcoves with seats are to be provided, in which to rest by the way. The whole of the ascent will be illuminated at night by electric lamps. In the basement a circular dancing pavilion, calculated to seat several thousand persons, forms a feature of the scheme. It is proposed that the decoration of the pavilion shall be floral in design, with electric lights in harmony of colour grouped in the centre, and imitation foliage and flowers. The plans also provide for the laying-out of the remainder of the grounds with bandstand and kiosks. The first round from the base of the tower will be an imitation of an Eastern street, with café and buffet in keeping therewith. Outside the tower, on the ground floor, it is proposed to erect shops, with waiting and retiring rooms. The design throughout is Oriental in character. The designer and patentee is Mr. Tom Bradley, architect and surveyor, Bingley, with whom Mr. John Tillotson, auctioneer, Bingley and Bradford, is associated in the undertaking. Messrs. W. H. and A. Sugden, of Keighley, are the architects for the structure.

**PERTH.**—Lieut.-Col. Frederick Bailey, late R.E., Edinburgh, held a local inquiry last week into the scheme of the Perth Police Commission, under the Perth Improvement Act, in regard to the housing of the working classes. The memorial presented to the Secretary for Scotland set forth that for the purpose of making certain new streets, it was necessary to acquire 130 houses, occupied by persons of the labouring classes, whereof 50 are situated between South-street and City Hall, and 80 in the Old High-street. Evidence was given to the effect that the Commissioners proposed to demolish 139 houses and erect 104, while there were 92 unoccupied houses within a radius of a mile. At the close of the inquiry, Colonel Bailey said he should have pleasure in reporting to the Secretary for Scotland that the scheme seemed to him, in every respect, an excellent one. He hoped it would be very speedily carried out.

**SEAFORD.**—The Simmons Church Institute at Seaford has just been opened by the Bishop of Chichester. The building is situate in Crouch-street, and makes a decided addition to the buildings of the town, and is described as of picturesque appearance, quaintly designed. The walls, after the Sussex fashion, are constructed of flint boulders, with red brick dressings. The tiled roof has boldly projecting eaves. The hall is well lighted, and has an open-timbered roof in pitch-pine, with moulded principals and pendants stained oak colour. At the rear are retiring and committee-rooms. Mr. C. Morling, of Seaford, is the builder, and Mr. H. Curtis Card, F.S.I., of Lewes, is the architect. The cost of the hall, exclusive of the site, was £1,000. The land and the equipments of the institute were also included in the gift which has been made to the parish by Mr. Henry Simmons, one of the oldest residents in Seaford. The hall seats about 150 persons. The building is set well back from the road, and is inclosed by iron railings, with moulded brick piers at intervals.

**SOLIHULL.**—At Tuesday's meeting of the board of guardians, the special workhouse accommodation committee recommended the erection of an

infirmary to accommodate 32 males and 32 females, including lying-in ward, two rooms for special use of workhouse medical officer, nurses' rooms, &c., isolation ward (four beds), tramp wards for 40 males and 24 females (including six separate cells for males and six for females), together with the necessary offices in connection therewith. The new buildings recommended are in accordance with plans prepared by Mr. W. H. Ward, architect, of Birmingham, who estimates the cost at £10,000 to £12,000. Further discussion of the report was adjourned for a month.

**WELSHPOOL.**—The new Intermediate schools were formally opened, on Friday, by Sir George W. Kekewich, K.C.B., Secretary of the Education Department. The schools are situated in Severn-street, near the Cambrian Railway Station, and in style are a modern adaptation of Late Renaissance. The materials used are Buttington red bricks with dressings of stone, and Ruabon tiles. The building accommodates 75 boys and a like number of girls. It is fitted with a kitchen and laundry on the ground floor, and a chemical laboratory and science lecture-room are provided on the upper floor. The headmaster's and headmistress's rooms are centrally placed. The assembly hall will seat 300 people, and the low-pressure hot-water system, with radiator, is employed for heating. The building has been erected by Messrs. Bradney and Lloyd, of Shifnal, from the designs and under the supervision of Mr. Frank H. Shayler, with Mr. Potter, of Welshpool, as clerk of the works. The original contract for the school was £3,060, and the total cost has been £3,106 1s. 6d.

**WINCHESTER CATHEDRAL.**—The central position of the magnificent 15th-century altar-screen in Winchester Cathedral is at last about to be completed. At present the figures of the Blessed Virgin and St. John are gazing up at an empty cross. A design prepared by Mr. G. F. Bodley, A.R.A., has been recently approved by the Bishop, the Dean, and the Chapter, and Canon Valpy has offered to present the work as a memorial of his wife. The design now accepted includes, in addition to the central figure of our Lord on the Cross and some ornamental work surrounding it, a piece of sculpture below the cross, representing the Nativity, with six figures of female saints (three on either side), which will fill the upper portion of the space now occupied by Sir Benjamin West's picture of the Raising of Lazarus. Mr. Bodley has insisted on the removal of this picture as essential to a satisfactory restoration of the screen, it being out of harmony with the general character of the work into which it has been obtruded. Canon Valpy's munificent gift will cost about £1,800. The execution of the work has been intrusted to Messrs. Farmer and Brindley, who undertake to complete it in the course of next autumn.

**WOODVALE, BELFAST.**—The memorial-stones of a new Presbyterian church in course of erection in Shankill-road, Woodvale, Belfast, was laid on Saturday. Upwards of 1,000 sittings being required at a moderate expenditure, the plan of a simple nave and aisles, with shallow transepts occupying an oblong space of about 90ft. by 70ft., was adopted. A feature is the main doorway, placed in the centre of gable with splayed jambs and moulded arches. Above a granite central shaft will be a carving of the "burning bush." The tower, which is pierced by lancet windows, and crowned by a cornice and stone spire, rises to a total height of 120ft. An angular projection is placed on the opposite angle of main gable. All the large windows have stone mullions and cusped tracery heads. At the transepts the windows rise to a higher level. All the gables have copings and apex stones. The walling is of Silurian slate rubble-work, from Ballygowan, County Down, with dressing and quoins of Giffnock sandstone. The internal joinery will be of walnut and pitch-pine, with sheeting of Carolina pine, varnished. The roof of open timber-work will be exposed to the ridge, and sheeted between the principals. A space has been reserved at the rear of the church for a lecture-hall. The contractor for the entire work is Mr. Thomas McMillan, Ormeau-avenue, and the architects are Messrs. Young and Mackenzie, Belfast.

The opening of the new public buildings for West Bromwich will take place on Monday next. They provide offices for the town council, are situated at Hill Top, and have been erected from plans by Mr. Greatorex, the borough surveyor.

## PROFESSIONAL AND TRADE SOCIETIES.

**LANCASHIRE AND CHESHIRE ANTIQUARIAN SOCIETY.**—The members of this society visited, on Friday, Wardley Hall, Worsley, which has lately undergone a complete restoration. Mr. G. C. Yates (who led the party) read a paper, in which he gave some historical account of the old building and pointed out its more interesting features. When the work of restoration was commenced, he said, it soon became apparent that there was much more of interest in the house than was at first supposed. In all cases where there were beautifully-panelled ceilings, formed of massive and richly-moulded oak beams, it was found that the most prominent of the mouldings had been roughly chopped off, and on or below them had been nailed laths, and the whole hidden by plastered ceilings. Where the larger beams projected—all being of oak—they had been at some former period hacked over and covered with plaster, their sections being converted into plain rectangles with chamfered edges, and (as if to add insult to injury) these "improved" beams had been painted and grained in imitation of oak. The fine old staircase had been similarly treated. The whole has now been restored as far as possible. Visitors to Wardley Hall, Mr. Yates said, will probably miss some of the black and white work with which they were so familiar, but as all that on the north front was sham—being painted plaster, and not timber work at all—it was thought best not to replace it, but to restore the old brick walls which it covered. The restoration, though a costly matter, has resulted in saving from ruin one of the most interesting old houses in Lancashire. The skull—popularly supposed to be that of Father Ambrose—which has been preserved at Wardley Hall for generations, was during the progress of the work placed in an iron safe, and afterwards reinstated in the niche upon the staircase where it has so long lain protected with glazed doors.

**GLASGOW ARCHITECTURAL ASSOCIATION.**—The annual business meeting of the Glasgow Architectural Association was held in the rooms, 187, Pitt-street, on Tuesday, 7th inst., the President, Mr. W. T. Conner, A.R.I.B.A., in the chair. The secretary read the annual report, including the statements of the treasurer and librarian, which shows the association to be in a flourishing condition. During the session 19 new members were admitted, making an increase in the roll over last year. The syllabus comprised nine members' papers and lectures, over and above which there were four exhibitions of drawings and photographs. There have been three prizes offered for competition, of the respective values of £10 10s., £5 5s., and £2 2s., the first being for a design, and the other two for measured work and sketches. The treasurer's account shows a balance of £41 3s. 6d. on the credit side. The librarian's statement enumerates valuable additions by purchase and donation. The following gentlemen were elected to hold office during the coming session:—President, Mr. G. S. Hill, A.R.I.B.A.; Vice-Presidents, Messrs. John Fairweather, R.I.B.A., and C. E. Whitelaw; Hon. Secretaries, Messrs. R. J. Walker and Alex. Wingate; Hon. Treasurer, Mr. W. S. Tucker; Hon. Librarian, Mr. Hugh Dale; General Committee: Messrs. James Lochead, A.R.I.B.A., Wm. Vickers, W. J. Blain, and Thos. Ramsay.

The sales registered at the Estate Exchange during last week amounted to £180,816, as against £114,050 in the corresponding week of last year.

At the parish church of Newtown, near Wem, a new pulpit and chancel screen, erected from designs by Mr. A. E. Lloyd Oswell, of Shrewsbury, have just been completed. The screen, which is Early English in style and of wrought iron, is by Messrs. Hardman and Powell, of Birmingham, and the pulpit, which is in the same style, and is executed in red Mansfield stone and alabaster, is by Mr. Bowdler, of Shrewsbury.

Oak House and grounds, West Bromwich, which were presented to the town some time ago by Alderman E. Farley, will be thrown open to the public on July 25. The Earl of Dartmouth has consented to perform the opening ceremony. The Science and Art Department have promised a loan of curiosities for a few months, and local gentlemen will lend pictures and other objects of interest. In addition to the improvements effected so far as the building is concerned, the grounds surrounding the old house have been laid out, and a large bowling-green has been provided.

## PARLIAMENTARY NOTES.

**THE HOME OFFICE BUILDINGS.**—Replying to Mr. Allhusen, Mr. Akers-Douglas said, on Monday, that he did not think that it would be possible to set aside any of the money provided by the Public Buildings Expenses Act of this session for the completion of the Whitehall front of the Home Office buildings.

## CHIPS.

The Burnley Town Council have appointed Mr. J. P. Greenwood, of Barry, Glam., as assistant borough surveyor, at a commencing salary of £150 a year.

An adjudication in bankruptcy is announced in the case of Henry Hulse, trading as A. and H. Hulse, of Winsford, builder, contractor, and brick manufacturer.

The Municipality of Perugia, having determined to repave the Cambio, have intrusted the work to Cav. Tesorero, Technical Director of the Industrial School at Naples, who designed the tile pavement for the recently-opened Appartamento Borgia at the Vatican. The new pavement of the Cambio will also be 15th Century in style, and executed in Roman majolica tiles.

The eastern portion of High-street, Kensington, is about to be widened between Kensington Palace Gardens and Church-street, at a cost of about £80,000, jointly borne by the vestry and the London County Council. The street, which now has a minimum width of 29ft., will be made uniformly 60ft. wide.

The Hull City Council has committed itself to a series of improvement schemes which, according to Alderman Jarman, chairman of the Finance Committee, amount to the enormous total of £6,000,000.

The account of the capital expenditure on their Municipal Technical School will be presented to the Birmingham City Council in July. At present the revision is not quite complete, but the total expenditure for site, building, and complete equipment of the school will amount to a little over £89,000. The total expenditure authorised by the council was £84,558.

The well-known Camden House and estate at Chiselhurst, which was the home for some years of Napoleon III., and after his death of the Empress Eugenie, is to be saved from the hands of the builder. A syndicate of the residents has been formed, and £33,000 raised to purchase the historic mansion and 70 acres of land. The property will be used for golf links, and the mansion converted into a club-house.

The newly-erected Corporation Art Gallery at Reading has just received the gift of a painting by the late J. B. Burgess, R.A. The picture, which measures 5ft. by 4ft., has been presented by Mrs. Burgess by desire of her late husband, the artist. It represents the Spanish painter Alonzo Cano giving away his sketches as alms to the poor.

The vacation travelling scholarship, instituted a year ago by the Boston Architectural Club, has been awarded for the present year to Mr. Albert C. Fernald, whose trip is to be devoted particularly to the study of the architecture of northern Italy.

The inventory of the heritable and movable estate of the late Mr. George Russell, sculptor, Aberdeen, who died in April last, amounts to £11,987 6s. 1d. Of this sum £4,216 14s. 1d. is personal estate, and £7,770 12s. heritable estate. Mr. Russell leaves his whole estate, after payment of his debts, funeral expenses, and expenses of management, to be divided between the police force and the scavenger force of the City of Aberdeen, in shares of £5 each—"Each body to get a number of shares equal in proportion to the number of such body."

The work of renovation at Cavendish Chapel, Manchester, is approaching completion. The building has been overhauled and repaired on the outside. Inside, the roof, walls, and pews are all being cleaned and beautified. The varnish and other accumulations of nearly half a century have been removed, and the mellowed oak and pitch-pine are once more visible in their natural beauty. The stained-glass windows at the north and south ends of the building have been repaired and cleaned. Tiles are being laid at the front entrance lobbies. The heating apparatus is also being renewed; the order for a new organ has been placed. The electric light has been laid on. The reopening service of the chapel, erected just fifty years ago, and sometimes called the Cathedral of Northern Nonconformity, will commence on Sunday next.

It has been decided by the committee who have raised subscriptions for a memorial to the late Dean Montgomery that the memorial (a recumbent effigy in marble of the Dean) shall be placed in St. Mary's Cathedral under one of the arches which separate the sanctuary from the north choir aisle. A sub-committee has been intrusted with the selection of a sculptor; and Mr. H. J. Blanc, R.S.A., architect, is to design the base on which the figure will rest.

CONTENTS.

The Revised Schedule of Professional Charges ... 839  
 Dudley Gallery Art Society ... 839  
 Model Specifications.—XVII. ... 840  
 Society of Engineers ... 842  
 Electric Lighting Notes for Architects.—XXIV. ... 842  
 New Entrance Hall, Barton Court Hotel, New Milton, Hants ... 845  
 Royal Architectural Museum ... 845  
 Ironwork at South Kensington Museum.—VI. ... 846  
 Decoration of Furniture and Woodenware ... 846  
 District Surveyors' Association Dinner ... 846  
 Cost of Pile-Driving with the Steam-Hammer ... 846  
 Books Received ... 847  
 Engineering Notes ... 848  
 Building Intelligence ... 849  
 Professional and Trade Societies ... 850  
 Parliamentary Notes ... 850  
 THE BUILDING NEWS DIRECTORY ... IX.  
 Our Illustrations ... 851  
 Competitions ... 851  
 Correspondence ... 870  
 Intercommunication ... 870  
 Legal Intelligence ... 871  
 Statues, Memorials, &c. ... 872  
 Water Supply and Sanitary Matters ... 872  
 Our Office Table ... 873  
 Meetings for the Ensuing Week ... 873  
 Trade News ... 874  
 Latest Prices ... 874  
 List of Competitions Open ... 875  
 List of Tenders Open ... 875  
 Tenders ... 878

ILLUSTRATIONS.

STUDY FOR THE TOWER OF A CIVIC BUILDING.—THE "RED HOUSE," HARPENDEN, HERTS.—THE PASSMORE EDWARDS CRIPPLES' HOME, ALUM CHINE, BOURNEMOUTH.—MILL HILL SCHOOL NEW CHAPEL.—NEW ENTRANCE HALL, BARTON COURT HOTEL.—DETAILS OF THE CLEVELAND CHAMBER OF COMMERCE.

Our Illustrations.

STUDY FOR THE TOWER OF A CIVIC BUILDING.

This composition for a tower and gable end of a civic building is conceived in a style described by the author, as being "devoid of the better principles of architectural design," and he admits that his conception disregards "modern practical requirements." There is, however, a freedom from restraint in his proposal which, notwithstanding a certain redundancy of detail, is marked by an endeavour to realise a breadth of treatment which shall accord with the scale of its enrichments. Mr. Robert Boughton says the scheme is designed in a modern French spirit, with peculiarities and details which he would not hesitate to carry into execution. The desire for originality thus displayed, at least, is interesting, and, at any rate, the tameness of the ordinary and commonplace has been somewhat vigorously avoided. The bold handling of the drawing harmonises with the design, so that the sketch, it may be readily acknowledged, makes an attractive, if somewhat unusual plate.

THE "RED HOUSE," HARPENDEN.

This country house, the residence of Mr. A. Vaughan Stevens, has lately been erected on the site of a former building which two or three years since was destroyed by fire. The new house, as shown by the accompanying plans, is entirely unlike the previous one, though the foundations of the original building determined the shape on the plan of the leading walls of the present one, with a trifling extension at the end of the billiard hall, and of the cloak-room and pantry to the rear. The roominess and spaciousness of plan, coupled with the isolation of the kitchen and servants' departments, which are also contrived for ready service, may thus briefly be referred to. The building is in red brick, with Portland stone entrance, and St. Aldhelm quarries Bath stone dressings elsewhere, the roofs being covered with tiles. The windows are throughout fitted in the transomed lights with metal casements, by Messrs. Wenham and Waters. The Cadogan Ironworks supplied the steel girders. The quarried and shaped glazings were executed to special patterns by Messrs. Aldam Heaton and Co. The carving was done by Mr. Nathaniel Hitch. The purpose-made copper furniture was supplied by Messrs. Hart, Son, Peard, and Co., who did the wrought-iron work. Oak floors are laid in all the best rooms, and American white wood, stained dark oak, is employed for the joinery where oak itself is not used. The chimneypieces were supplied by the Coalbrook Dale Company, where special ones were not introduced. The white and black marble paving was supplied by Messrs. Farmer and Brindley.

A feature is made of the hall and staircase, with its gallery over, and another point of interest is the ingle in the dining-room. The well-matured grounds and well-kept gardens surrounding the house add much to the interest of the building. The general contractors were Messrs. C. Miskin and Sons, of St. Alban's. The architect is Mr. Maurice B. Adams, F.R.I.B.A.

PASSMORE EDWARDS CRIPPLES' HOME, BOURNEMOUTH.

THE building, as shown in the illustration, has been erected on a charming site in Alum Chine, by the liberality of Mr. J. Passmore Edwards, whose gift it is to the Ragged School Union, and will accommodate about 25 crippled children. The architect is Mr. Frederick Warman. The Marquis of Northampton, as president of the Ragged School Union, opened the home on Tuesday last. Nearly 40 friends travelled from London to attend the ceremony, among them being Lord Northampton, Mr. Henry Wood (chairman of the Ragged School Union), and Mr. J. Passmore Edwards. The Mayor of Bournemouth, who presided, said he felt sure that Bournemouth would help forward the new home, as they were already helping so many other local institutes of a philanthropic character. Lord Northampton expressed the pleasure it always afforded those engaged in Ragged School Union work to receive letters of sympathy from outside London. When the offer came from Captain and Mrs. Harrison to start a temporary cripples' home in Bournemouth, his advice to the secretary was to "jump at it." He acknowledged the great debt of gratitude owing to Mr. Passmore Edwards for a further proof of his generosity in erecting the home, and hoped his example would be followed, so that all the 6,000 crippled children under the notice of the Ragged School Union might spend part of their lives beneficially at Bournemouth or some other seaside resort.

MILL HILL SCHOOL CHAPEL.

ON Wednesday next, the 22nd inst., this important and interesting addition to the buildings of Mill Hill School is to be opened. The architect is Mr. Basil Champneys. The drawings which we give to-day somewhat fully illustrate the work, which is marked by several distinguishing features. The enriched plastered ceiling of the interior adds much to the effect of the chapel, which is, of course, seated college fashion. The vestry is situate on one side of the sanctuary, and the organ is placed on the other, a projecting gallery being contrived over the stalls on the vestry side facing the organ. There is a public gallery at the west end. The materials are red brick and stone, with tiles for the roofs.

CLEVELAND CHAMBER OF COMMERCE.

WE give this week a double page of detail of this building, which we illustrated last week, and of which Messrs. Peabody and Stearns are the architects. Both illustrations are produced from the *American Architect*.

CHIPS.

The urban district council of Wallasey have decided to purchase the Woodlands Estate, adjoining Liscard Vale, and having a frontage to the esplanade, for conversion into a public park. The estate contains 12,500 square yards, and the price given is £3,500.

At the last meeting of the plans committee of the Aberdeen Town Council, plans of new buildings representing a value of £7,500 were approved. The plans include an addition to the convent of St. Margaret's at Spital.

At the Wesleyan chapel, Lichfield, a new organ, built by Messrs. Nicholson and Lord, of Walsall, was opened last week.

The Local Government Board have intimated that they will assent to a loan of £40,000 being raised by the Exeter City Council, for the purpose of carrying out the Cameron scheme for disposing of the sewage by the aid of the septic tank. Under this system the sewage is destroyed by bacteria.

The Barlow Recreation Ground at Blackpool Bridge, Bury, Lancs, is about to be laid out from plans by Mr. J. D. Mould, architect, of Bury and Manchester.

The second electric tram line into Dublin—that from Haddington-road to Nelson's Pillar—has now been completed. On this line centre poles are laid for the entire distance, but in other respects the installation is the same as that on the Clontarf section.

COMPETITIONS.

PLYMOUTH.—The town council recently decided, in response to a memorial from the local architects who were invited to send in competitive designs for the buildings to be erected in Tavistock-road and Tavistock-place, to increase the premium for the best design from £150 to £250. The architects replied to this by an expression of regret that the main point of their objection to the conditions had not met with a more favourable reception. The town clerk was thereupon requested to ask whether, if the Special Works Committee were prepared to consider the suggestion submitted, the architects would waive their requirements in relation to the appointment of a professional assessor. To this the architects replied unanimously declining to compete unless a professional assessor was appointed. The committee then resolved that the views of the architects be met by the following:—A professional assessor to be agreed to, provided the plans become the property of the Corporation, the premium to the successful architect to be £250, and competitors to be instructed that the rents to be catered for are to be about £100 per annum, with the exception of the two end sites, which are to be specially treated. The remuneration of the assessor is to be fifty guineas. The town clerk is to obtain the views of the architects upon the offer as it now stands, with a view to obtaining the sanction of the committee to the selection of an assessor.

TROWBRIDGE.—The local Technical Education Committee recently invited architects to submit designs for a proposed technical institute, a feature of the competition being that the first premium of £40 was not to merge in the successful architect's commission, as is too usual, but that he was to be paid the customary 5 per cent. The limit of cost was £5,500; designs were to be sent in by May 28; and Mr. Edward W. Mountford, F.R.I.B.A., of London, was appointed assessor. Sixty-seven designs were received, and the assessor's award, which has been adopted, is as follows:—First premium (£40): Mr. Thomas Davison, A.R.I.B.A., 59, Great Ormond-street, W.C. Second premium (£30): Messrs. Briggs and Wolstenholme, Central Buildings, Richmond-terrace, Blackburn. Equal third premium (£20, to be divided): Mr. A. Dunbar Smith, 28, Theobald's-road, Gray's-inn, W.C.; and Messrs. A. G. Hall and Thos. H. Bishop, Jun., A.R.I.B.A., Leighton Buzzard. Highly commended: Mr. T. E. Thickpenny, A.R.I.B.A., Breydon House, Lansdowne-road, Bournemouth, and Messrs. J. H. Tyars and E. T. Jago, 16, Garfield-road, Lavender Hill, London, S.W.

WIMBLEDON.—Colonel C. A. Luard, C.E., a Local Government Board inspector, has held an inquiry into the application of the urban district council for sanction to borrow £1,050 for the purchase of land in South Wimbledon as a site for the proposed public baths. The district council has decided that the following architects be invited to compete for the plans:—Mr. W. E. Hewitt, Mr. R. J. Thomson, Mr. R. A. Hinds, Mr. A. Ardron, Messrs. G. Elkington and Sons, and Messrs. F. J. Smith and Maurice B. Adams. The total cost is not to exceed £7,000.

A new chancel screen designed by Mr. G. F. Bodley, A.R.A., was unveiled last week at the parish church of Church Stretton.

The Theatre Royal at Barnsley is being built from plans by, and under the supervision of, Mr. Herbert Crawshaw, of 13, Regent-street, in that town.

Mr. Tom Vickers, surveyor, Newark Rural District Council, was on Monday last appointed surveyor to the Bisley Urban District Council. There were 119 applicants for the post.

An agricultural college under the Harper-Adams Foundation is to be built at Edgmond, near Newport, Salop, and tenders have been accepted from Mr. John Gethin, Shrewsbury, for the main building, and Mr. Muirhead, Newport, for the outbuildings. The site of the college is on the road leading from Newport to Shrewsbury, to which one of the frontages will face. The work will be put in hand in July.

Some new shops in course of erection at Castle Mona are nearing completion. The building of the premises had been carried out by a local tradesman, but the flat roofing, which is a novelty in the Isle of Man, is the work of the Vulcanite Roofing Company, Belfast, and has been completed under the supervision of Mr. Jno. Loughton, their Birmingham agent.

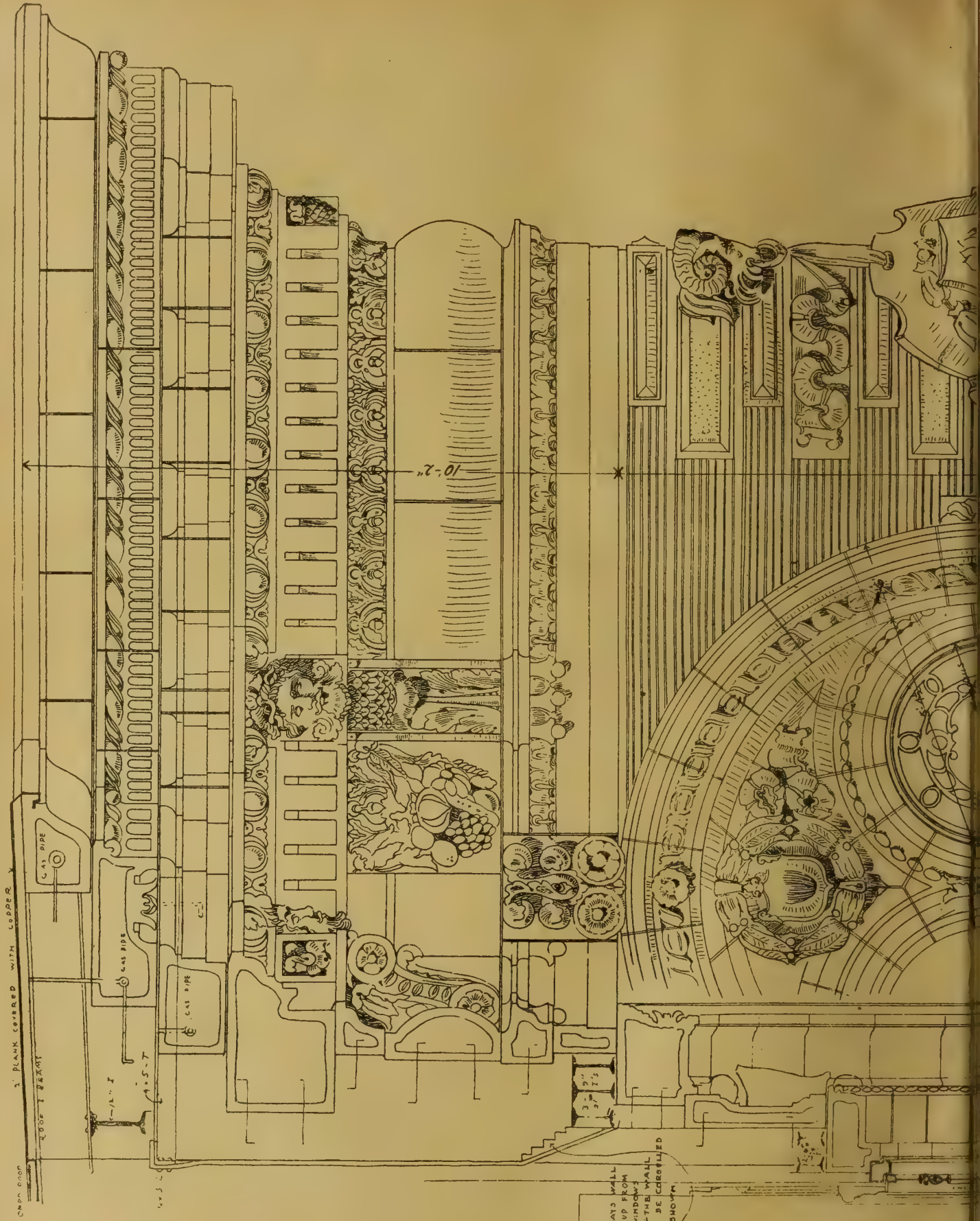

ROOF & GUTTER  
PLANK COVERED WITH COPPER

GAS PIPE

10'-2"

AT CORNER DAYS WALL  
TO BE CARRIED UP FROM  
BEAMS OVER WINDOWS  
BUT BETWEEN THE WALL  
WILL HAVE TO BE CARRIED  
OUT AS HERE SHOWN



## TO CORRESPONDENTS.

[We do not hold ourselves responsible for the opinions of our correspondents. All communications should be drawn up as briefly as possible, as there are many claimants upon the space allotted to correspondents.]

It is particularly requested that all drawings and all communications respecting illustrations or literary matter should be addressed to the EDITOR of the BUILDING NEWS, 332, Strand, W.C., and not to members of the staff by name. Delay is not unfrequently otherwise caused. All drawings and other communications are sent at contributors' risks, and the Editor will not undertake to pay for, or be liable for, unsought contributions.

Cheques and Post-office Orders to be made payable to THE STRAND NEWSPAPER COMPANY, LIMITED.

## TERMS OF SUBSCRIPTION.

One Pound per annum (post free) to any part of the United Kingdom; for Canada, Nova Scotia, and the United States, £1 6s. 0d. (or 6dols. 30c. 00). To France or Belgium, £1 6s. 0d. (or 33fr. 90c.). To India, £1 6s. 0d. To any of the Australian Colonies or New Zealand, to the Cape, the West Indies, or Natal, £1 6s. 0d.

## ADVERTISEMENT CHARGES.

The charge for Competition and Contract Advertisements, Public Companies, and all official advertisements is 1s. per line of Eight words, the first line counting as two, the minimum charge being 5s. for four lines.

The charge for Auctions, Land Sales, and Miscellaneous and Trade Advertisements (except Situation advertisements) is 6d. per line of Eight words (the first line counting as two), the minimum charge being 4s. 6d. for 40 words. Special terms for series of more than six insertions can be ascertained on application to the Publisher.

Front-page Advertisements 2s. per line, and Paragraph Advertisements 1s. per line. No Front-page or Paragraph Advertisement inserted for less than 5s.

Advertisements for the current week must reach the office not later than 3 p.m. on Thursday. Front-page Advertisements and alterations in serial advertisements must reach the office by Tuesday morning to secure insertion.

## SITUATIONS.

The charge for advertisements for "Situations Vacant" or "Situations Wanted" is ONE SHILLING FOR TWENTY-FOUR WORDS, and Sixpence for every eight words after. All Situation Advertisements must be prepaid.

## NOTICE.

Bound copies of Vol. LXXIII. are now ready, and should be ordered early (price Twelve Shillings each), as only a limited number are done up. A few bound volumes of Vols. XXXIX., XL., XLI., XLVI., XLIX., LI., LIII., LVIII., LIX., LXI., LXII., LXIII., LXIV., LXV., LXVI., LXVII., LXVIII., LXIX., LXX., LXXI., LXXII. may still be had, price Twelve Shillings; all the other bound volumes are out of print. Most of the back numbers of former volumes are, however, to be had singly. Subscribers requiring any back numbers to complete volume just ended should order at once, as many of them soon run out of print.

RECEIVED.—C. T. W.—A. M. and Co.—L. R. B.—O. K. G.—E. L. Co.—N. G. A.—W. S.

## Correspondence.

## STONE-CARVING IN NEW YORK.

To the Editor of the BUILDING NEWS.

SIR,—Amongst the pile of letters I find awaiting my return from South Africa is one from an old apprentice of my own, who now occupies, and most worthily so, a prominent position in New York. The following extracts bearing upon, in the main, architectural carving, will probably be read with interest by many of your practical readers.

Its writer says: "How time flies! It is now more than twenty years since I first entered your studios at Exeter. I was then a simple lad of sixteen summers, just fresh from school. What changes I have seen since then! I am grateful to say, however, I have received great profit during after life by your early instructions. The manner in which those teachings were administered I confess I thought a bit 'tough' at the time, but I am thankful enough for it now. I have since learnt to realise to the full that the greatest curse a young fellow can have in this 19th century is a 'milk-and-water' apprenticeship."

"Stone-carving here has undergone many changes during the last few years. A new school of artistic architects have risen up almost unconsciously amongst us. These are fast introducing a far better style of architecture into New York and the United States generally than was the last prevailing one—i.e., rude Romanesque à la Richardson. The style most affected now by our best and leading men is French Renaissance. The young architects here have, nearly all, more or less, been

students in the Ecole des Beaux Arts in Paris. This training has inculcated in them a deeper feeling than has heretofore existed on this side for refined ornament. Of course, the great drawback one has to deal with is that carving and architectural sculpture is looked upon by clients almost entirely from a commercial point of view. The average moneyed New Yorker has no artistic feeling within him. He worships the almighty dollar, and he wants as much as he can get for his money. Quantity, not quality! It is this would-be prostitution of art by the newly-made rich our architects have to fight so sorely against.

"In general building, machinery is used more than ever. It is especially largely introduced into stone-cutting. This has practically nearly wiped the stonemason proper off the face of the earth here. Those that are left are reduced to little better than mere mules, beasts of burden, with little else to do than superintendent fixing, and now and then knock off a joint. This saving of labour, however, has indirectly been advantageous at once to the stone merchant and to the stone carver. The master mason is now better able to compete with terracotta manufacturers. More stone is introduced on buildings than ever, and the carved decoration is of a much superior order, and infinitely more refined than formerly. During the last two or three years granite and marble (especially the former) have been even more largely introduced than heretofore. Its use does not, however, affect materially the labour market of New York, for it comes here in the main, all worked and ready for fixing, shipped direct from the practically exhaustless quarries in Maine and Vermont. There it is worked by imported Italians, who receive as remuneration next to nothing, live like the cattle of the field, in the companies' sheds, and purchase all the little they require at ruinous prices from the truck shops 'run' by their employers. The Italians and the *Padrone* system unitedly are the curse of American labour.

"Although more carving has been carried out here during the last few years than formerly, the increase has been of no material benefit to the employée individually. Unfortunately, the supply of carvers far exceeds the demand. There are always plenty of excellent workmen walking Broadway, with their hands in their pockets, chanting the mournful cry of: 'We've got no work to do.' This lack of employment is mainly due to the large immigration of carvers during the last five years from Italy and Germany. Strange to say, during that period of time we have only had three or, at the most, four carvers emigrate here (I am in a position to speak distinctly upon this) from the British Isles. These have all since returned, and many others, who found trade here so flourishing years ago, have gone back to England too, hopelessly dispirited, and penniless.

"As a matter of absolute fact, America is now no place for a working man. For those who have money to speculate, it is, perhaps, not a bad country: there are plenty of syndicates and trusts into which they may float their capital. At the same time, what in England would be justly termed 'roguey' is simply 'smart' here; and English speculators more often than not get their fingers burnt. They are seldom lucky enough to turn over the 'cent. per cent.' newcomers are often so sanguine of making.

"The Stonecarvers' Association in New York is quietly doing real good work, and its relations with those of the employers' association are excellent and cordial. All good work in the stone-carving line is now in the hands of three or four reliable firms, instead of, as formerly, spread about amongst thirty or forty, most of whose sole stock used to be half a dozen chisels, a hammer, swing-ladder, and paint-pot!

"We have had a fairly hard winter, the temperature being often at 39° below zero. Summer is now, however, smiling brightly upon us, and where a few months ago we were suffering from the bitter cold, we are, to-day, perspiring and gasping in the sun. The extremes of climate in this country are more trying than the average stay-at-home Englishman can form any idea of."

I am, &c.,  
Exeter.

HARRY HEMS.

The Parliamentary Committee of Newport Town Council recommend the purchase for £5,350 of a site, belonging to the Ecclesiastical Commissioners, near Caerleon, and containing about 53 acres, for the new borough lunatic asylum.

## Intercommunication.

## QUESTIONS.

[1966.]—**Ivywood.**—I should be glad of any particulars regarding the wood to be obtained from the stem of the common climbing ivy. I have a lately-felled specimen of 9in. diameter, which, being unseasoned, is difficult to judge, and therefore should like facts from any who may have had experience of this wood.—DARK GREEN.

[1967.]—**Testing Cement.**—Will feel much obliged if one of your practical readers would inform me of the proper way to test the strength of Portland cement, and also to name the best cement made.—STUDENT.

[1968.]—**Soundproof Walls.**—In building semi-detached villas, can any means be adopted to prevent transmission of sound from one house to the other?—M.

[1969.]—**Insurance.**—I am a jobbing and contracting builder, employing all branches of the trade, one-third of the men being constantly in employ, and the other two-thirds being migratory workmen, and it has occurred to me that a system of insurance might be adopted, and may be self-sustained by each workman paying a very small amount weekly. At present when a workman is ill his fellow-workmen and myself help him by subscription; but this is very unsatisfactory, for obvious reasons. I shall be glad if any of your readers have a workable scheme, and would inform me of the same through the medium of your valuable paper, as there is no doubt other employers would adopt any likely idea for what is a felt want in my district. The great difficulty with me is the fact that some of the workmen are only employed for two or three days, while others have been with me for twenty years.—ASSURANCE.

[1970.]—**Fixing Stone.**—Is a plugged joint with lead a reliable one for joining curbs and cornices? If there is any better mode of fixing other than cramping with metal, I shall be glad to hear. Also whether limestone is better than lead for fixing iron to stonework? There are some who say that it is not so good, as a chemical action takes place between the sulphur and stonework. Is Spence's metal better?—A LEARNER.

[1971.]—**Flare-Burnt Lime.**—This is burned in special kilns in which the lime is kept from contact with the fuel and smoke for the purpose of keeping it cleaner. Seeing that it is dearer than lime burnt in the ordinary kilns, what are the special purposes for which it is used, and where?—W. K. R.

[1972.]—**Hydraulic Engineering.**—Can anyone recommend an elementary treatise on practical hydraulics that will give all the necessary principles and applications to dams, river and quay walls, pipes and bends?—A. B.

[1973.]—**Drain-pipe.**—I intend to build six small houses, each house 15ft. by 23ft. internal dimensions, and two stories in height; yards 15ft. by 20ft. In each yard I intend to fit up a water-closet, which can be well flushed from town supply and properly equipped tank. I should like to know if a 6in. earthenware pipe is sufficient to carry off all slops from yards and closets. Some advise to lay a 9in. pipe, having 4in. connection to closets. I am sure many of your readers could advise me on this point, also as to ventilation. There is a fall of 5in. from *a* to *b*, and from *b* to *c* there is a fall 5in. in a distance of 35ft. The distance from *a* to *b* is 100ft., and I am anxious to know how to ventilate the sewer and connections in yards; also how I shall put in a trap near main sewer at *c*.—SANTAS.

[1974.]—**Chain Bond.**—I have to design a small stone dome about 12ft. in internal diameter. Is it necessary to have any tie, and what should it be like? I thought a circular flat bar jointed in four pieces would do. Should like some practical opinion on the best form and section, and how inserted at the base of dome.—CONSTRUCTION.

## REPLIES.

[1963.]—**Drawing.**—I have always understood that only absolutely black ink is suitable for process reproductions. Inks specially prepared for this purpose are sold at stationers.—LOUIS EWOLD.

[1964.]—**Woodworking Machinery.**—The machines that would suit you vary according to the size of your business, the amount you desire to lay out, and the kind of work you require to be done. There are numerous manufacturers of machinery who would gladly supply the information you require.—LOUIS EWOLD.

An interesting ceremony was performed at Bristol on Saturday last, when the city engineer, Mr. T. H. Yabbicom, C.E., on behalf of the officers in the city engineer's department, made a presentation of a handsome polished oak pedestal writing-desk to Mr. W. S. Skinner, on his resigning his appointment as architect under the corporation, to engage in private practice in the city.

The jury of the International Art Exhibition at Vienna have awarded their diplomas of honour, with 20 large and 39 small gold State medals. Three of the former and five of the latter were given to English exhibitors—namely, a large gold medal to Edwin Austin Abbey, A.R.A., for his "Hamlet"; to Arthur Hacker, A.R.A., for his canvas "The Cloister or the World?"; and to Edward Onslow Ford, R.A., for a plaster statue. A small gold medal was awarded to Frederick Arthur Bridgeman, in Paris, for his canvas of "The Terrace"; to R. B. Nisbet Comrie, Scotland, for his water-colour "Scotch Autumn"; to Charles Sprague Pearce, for his painting "Flock of Sheep"; to Ralph Peacock, London, for his painting "Falsehood"; to William Stott, of Oldham, for his "Kissing in the Ring"; and to Edward Stott, of Amberley, for his oil-painting "The Old Gate."



THE BUILDING NEWS, JUNE 17, 1898.

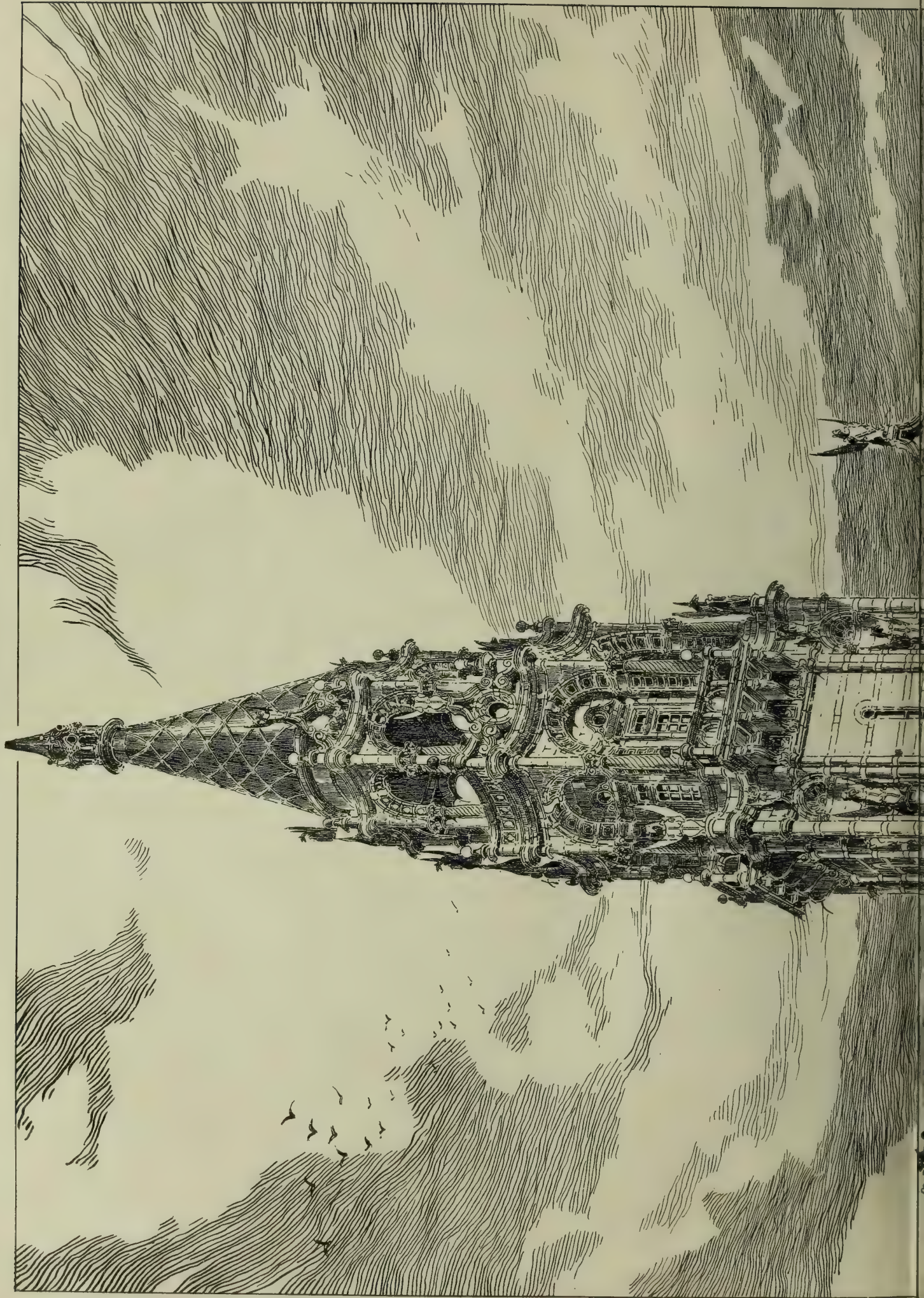



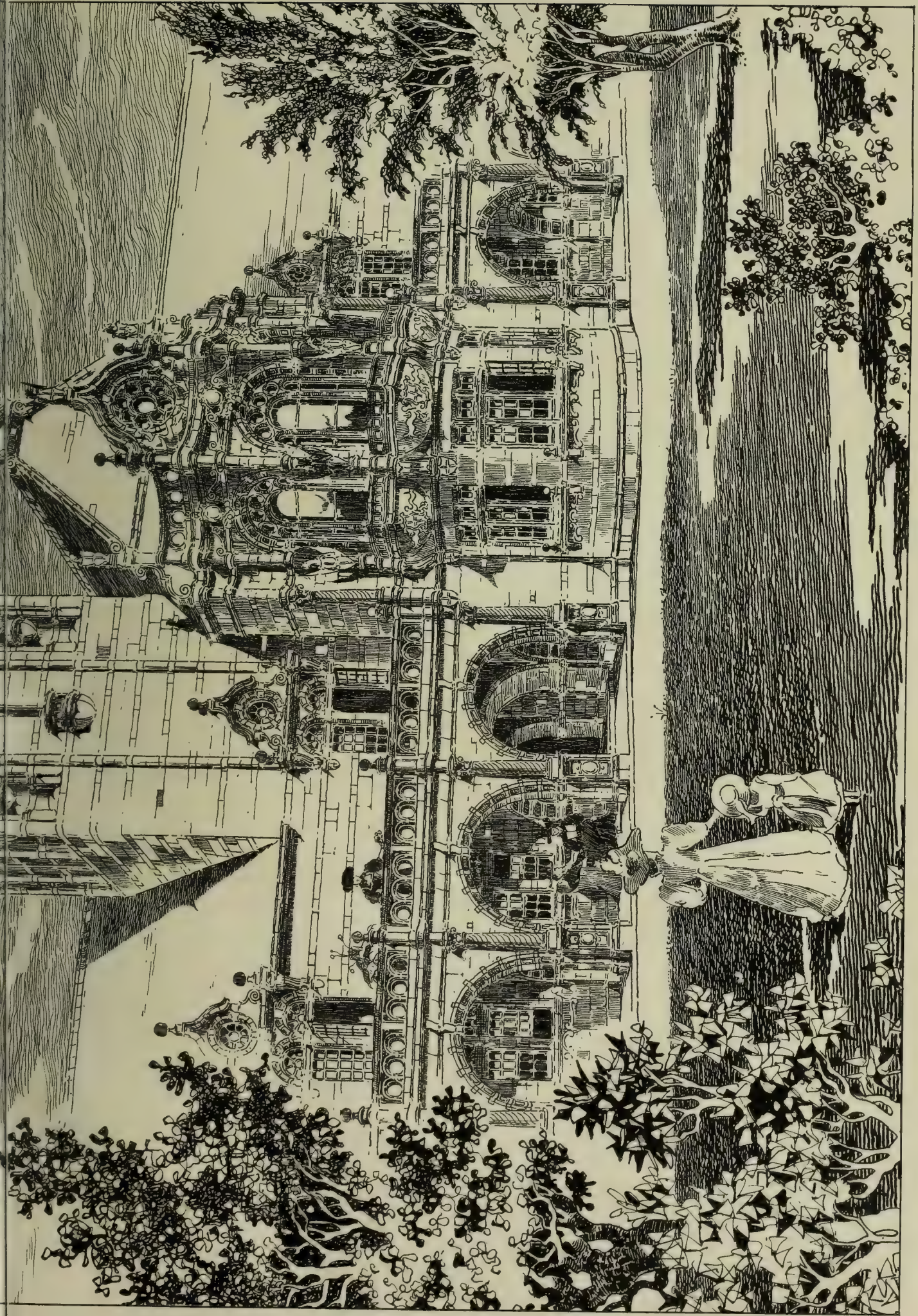

Photo Lithographed & Printed by James Abernethy, 6, Queen's Square, W. C.

STUDY FOR THE TOWER OF A CIVIC BUILDING.

BY R. BOUGHTON, ARCHITECT.





# THE RED HOUSE, HARE

for A.

PLAN

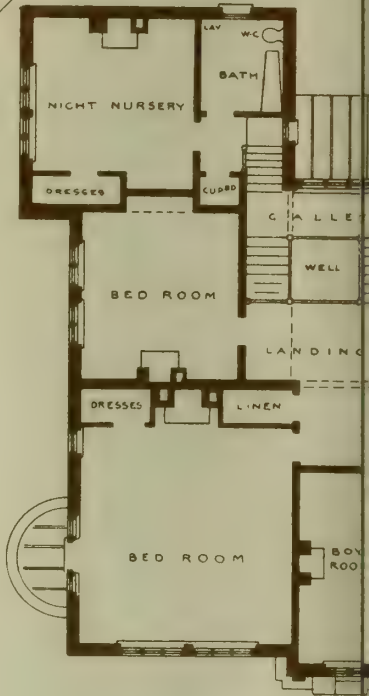
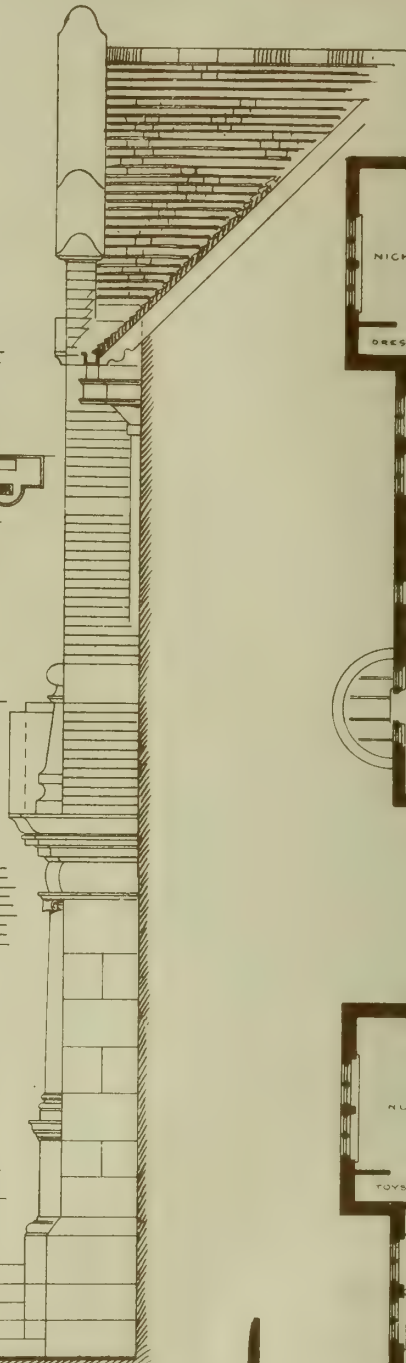

First Floor

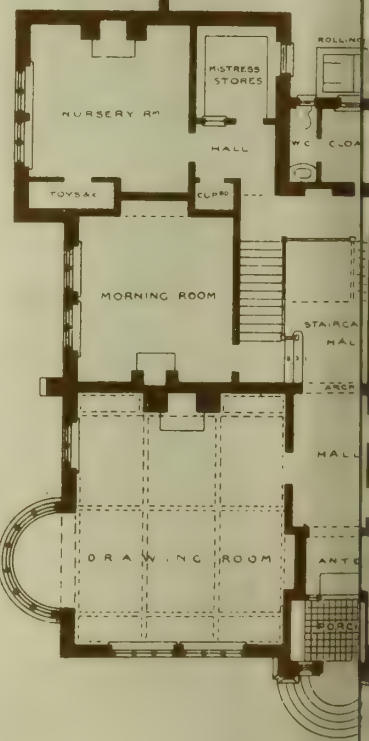

Ground

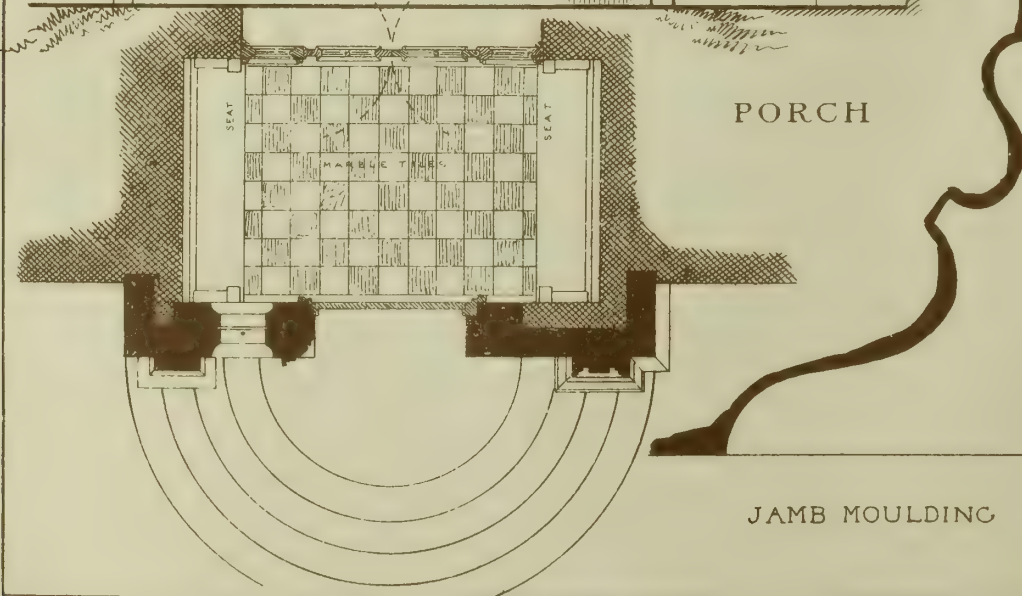

# PENDEN, HERTS.

Laughan Stevens Esq<sup>r</sup>e

## PLANS & DETAILS

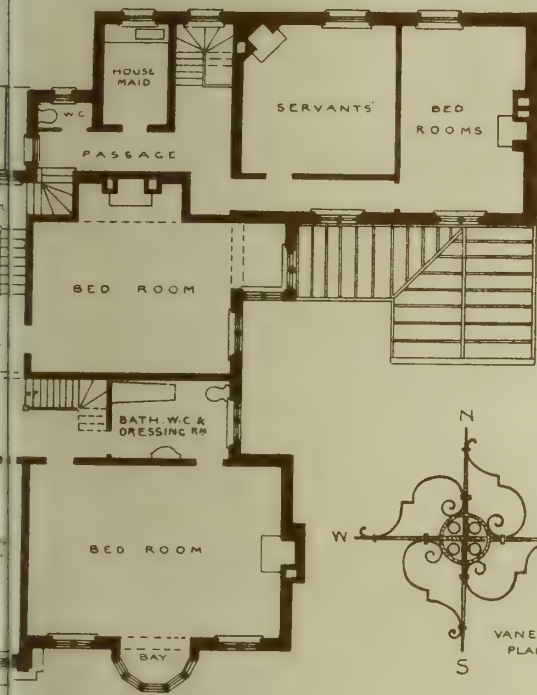

Plan

Maurice B. Adams  
Architect F.R.I.B.A.

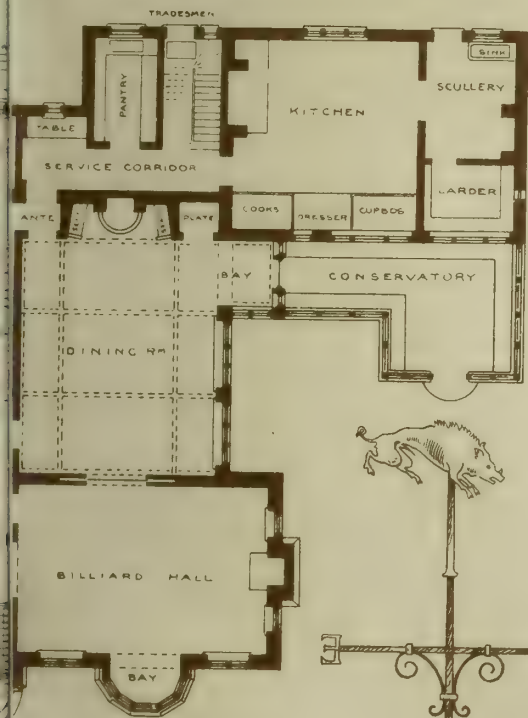

Plan

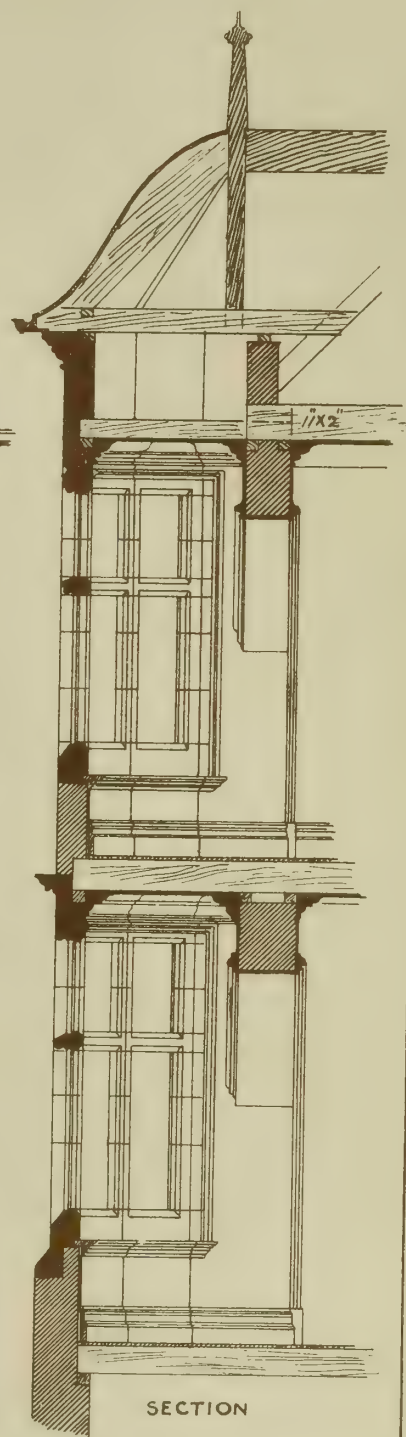
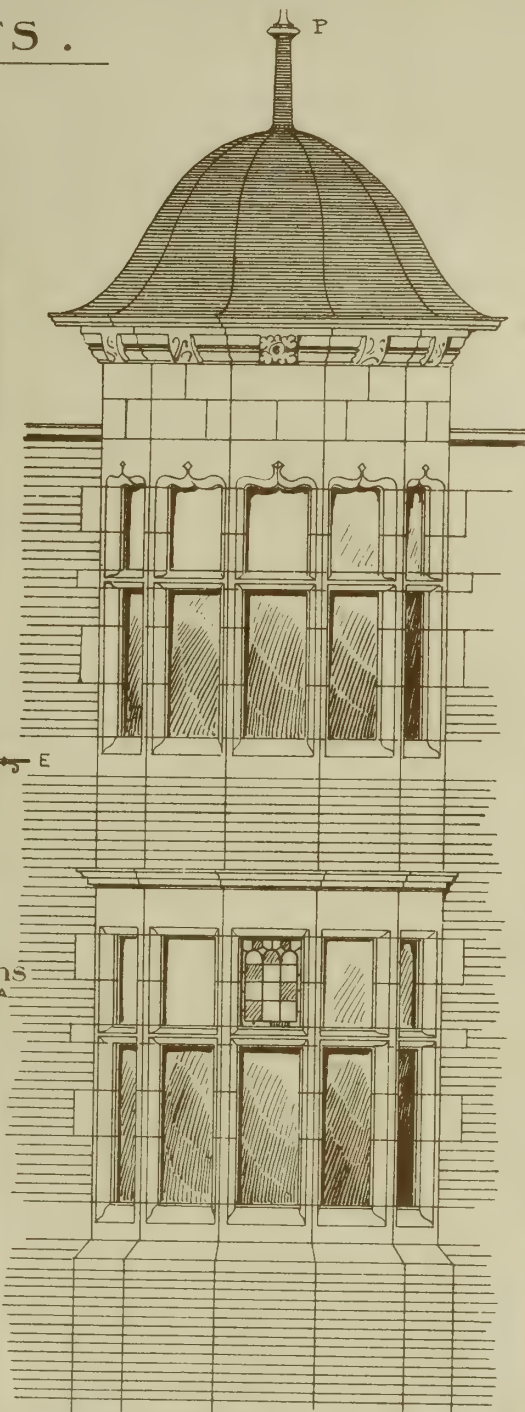

SECTION

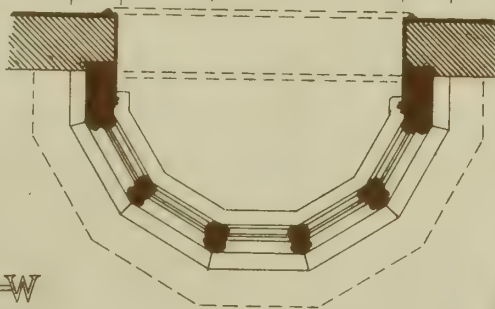

BILLIARD HALL  
BAY WINDOW

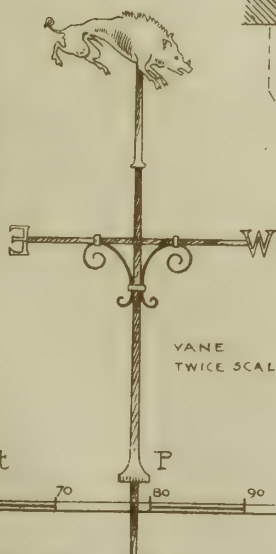

VANE  
TWICE SCALE

Scale of Feet



INTERIOR

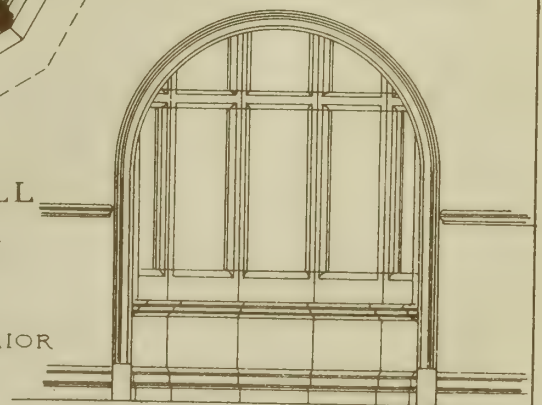







MILL HILL  
SCHOOL  
NEW CHAPEL  
BASIL CHAMPNEYS  
ARCHITECT

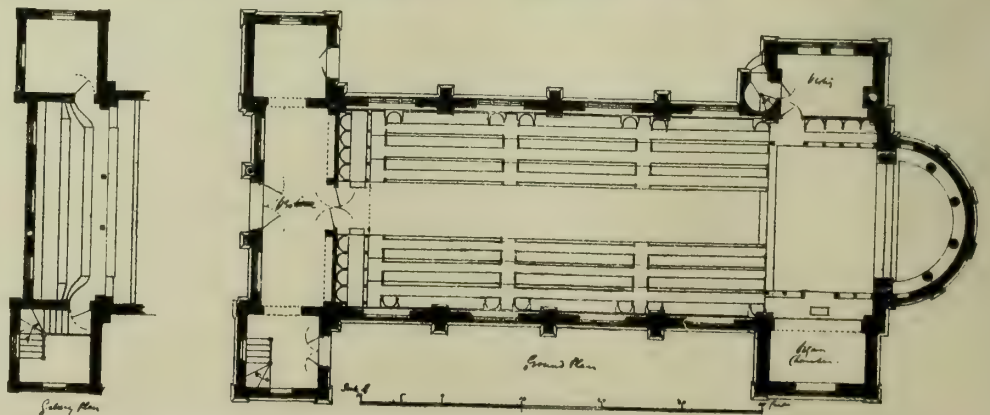





THE BUILDING NEWS, JUNE 17, 1898.



THE RED HOUSE HARPENDEN HERTS. THE RESIDENCE OF A. VAUGHAN STEVENS ESQ. MAURICE B. ADAMS, ARCHITECT.

The Engraver M.P. Print by Messrs. Agnew & Sons, London, W.

THE BUILDING BEGINS, JUNE 17, 1898.

· PASSEMORE · EDWARDS · CRIPPLES' HOME ·  
· ALUM · CHINE · BOURNE MOUTH ·

F. WARMAN ARCHT. MAY 1898.

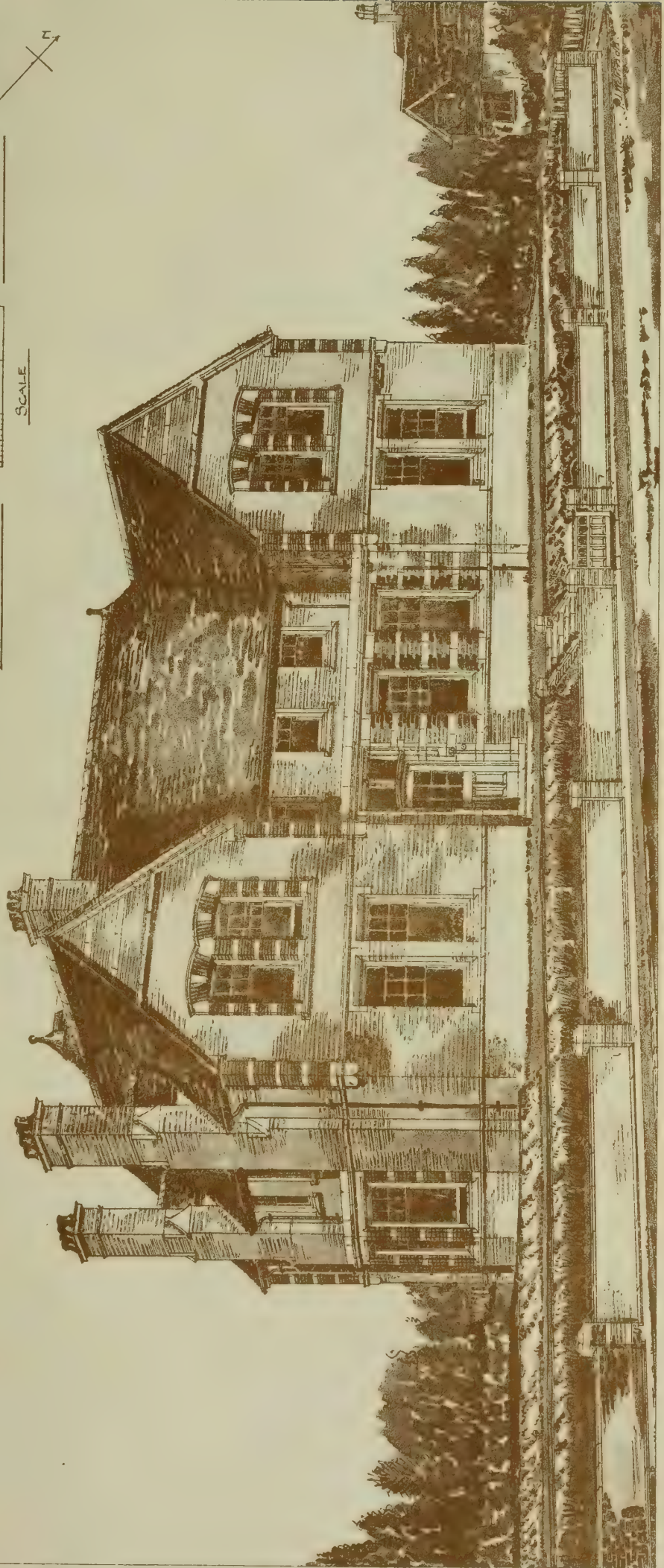
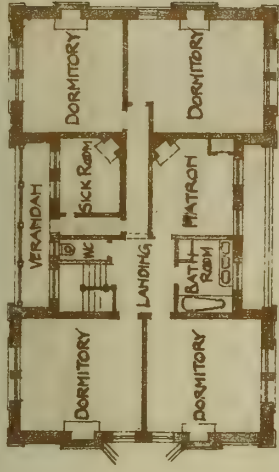
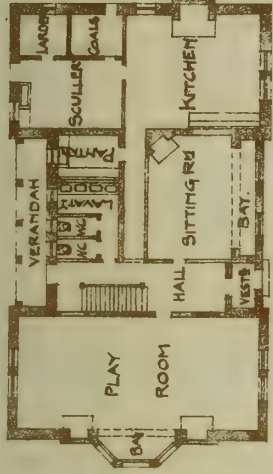

PHOTO-TINT BY AMER. ARCHT. BUREAU, CHICAGO, ILL.



THE BUILDING NEWS, JUNE 17, 1898.

# MILL HILL SCHOOL NEW CHAPEL

BASIL CHAMPNEYS ARCHITECT

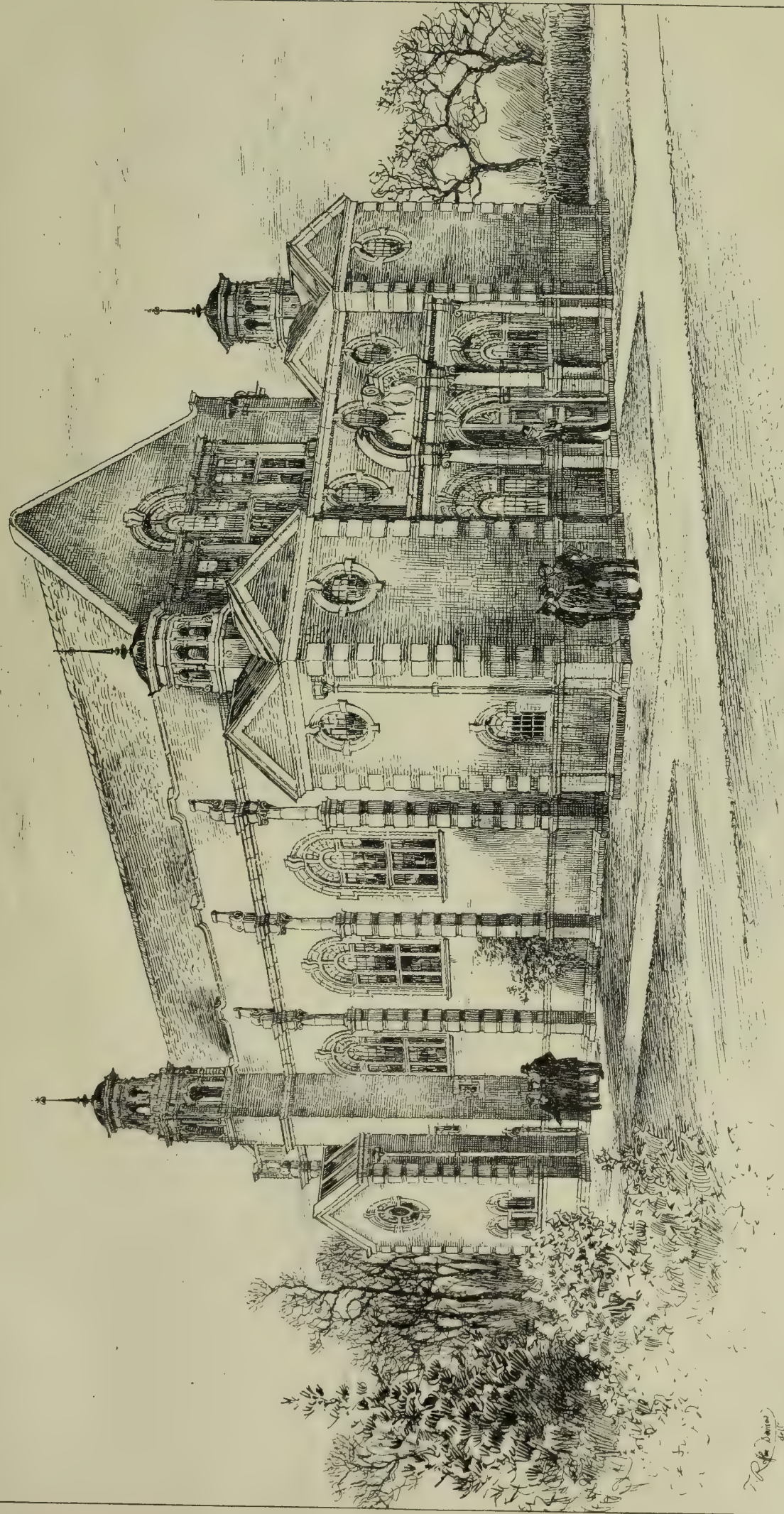



## LEGAL INTELLIGENCE.

**BOARD SCHOOLS AND THE DEPRECIATION OF ADJOINING PROPERTY.**—THE QUEEN V. PEARCE—**EX PARTE LONDON SCHOOL BOARD.**—In the Queen's Bench Division on Saturday, Mr. Justice Day and Mr. Justice Lawrence gave judgment in this application, which sought to make absolute a rule nisi that had been granted for a *certiorari* to bring up, for the purpose of being quashed, an inquiry, with the verdict and judgment thereon, taken before the Sheriff of London. The case arose out of proceedings for the assessment of the compensation due to Mr. Pearce, land belonging to whom at Maida Vale was compulsorily taken by the London School Board as the site for a school. The land taken formed part of a building estate near the recreation ground at Paddington, belonging to the claimant, Mr. Pearce. The estate was already partly built on, and in the proceedings for the assessment of the compensation, which took place before the Under-Sheriff of London and a jury, it was proposed on behalf of the claimant to give evidence that the houses on his estate in the immediate vicinity of the land taken would be depreciated in value owing to the noise that would be caused by the children attending the school. This evidence was objected to on behalf of the School Board on the ground that such depreciation in value did not form a subject for compensation. It was thereupon arranged that the jury should assess the compensation on this head separately in order that the question whether such compensation could properly be given might be brought before the High Court. The jury assessed the compensation on this head at £1,000. The rule nisi in the present case was then obtained. Mr. Freeman, Q.C., and Mr. E. Boyle appeared to show cause against the rule. They argued that, as part of the claimant's land had been taken, he was entitled to the compensation in question on the principles established in the case of "Duke of Buccleuch v. Metropolitan Board of Works," and "Cowper Essex v. Acton Local Board." Sir Edward Clarke, Q.C., Mr. Ram, and Mr. Marchant appeared in support of the rule. They contended that the damage to the claimant's property would not arise out of the use of the school by the School Board, but from the conduct of the children outside the school—a matter for which the School Board were not responsible—and that the damage, therefore, did not give rise to a claim for compensation. Moreover the school would not be erected for two years. They cited "Caledonian Railway v. Ogilvy," "City of Glasgow Union Railway v. Hunter." The Court discharged the rule. Mr. Justice Day said that it seemed to him, without giving any opinion as to whether the amount awarded by the jury was right, that the question had been properly left to the jury in accordance with established principles of law. Part of the claimant's land had been taken, and the jury had found that a school carried on in the usual way on the land so taken would injure the residue of the claimant's land; and they had assessed the injury at £1,000. That they were entitled to do, and it was not for the Court to say whether the sum awarded was reasonable or not. It appeared to him that there was no ground for disturbing the verdict of the jury. Mr. Justice Lawrence concurred.

**THE DRAINAGE QUESTION AT CONNAH'S QUAY.**—**THE ARBITRATOR'S AWARD.**—At Friday's meeting of the Holywell Rural District Council, a letter was read from the council's solicitor, inclosing the award of Mr. William Ambrose, Q.C., M.P., Vice-Chancellor of the Duchy of Lancaster, in the matter of the arbitration between the district council and the urban council of Connah's Quay respecting the liability of the latter to pay a sum of £796 8s. 8d. costs of preparing drainage plan, and of litigation with the London and North-Western Railway Company on the subject. Mr. Ambrose orders the Connah's Quay Council to pay to Holywell a sum of £378 4s. 2d. The costs of the arbitration (£132) are to be divided between the two bodies, and Connah's Quay are to have possession of the plans, &c.

**SERIOUS CHARGE AGAINST A BUILDER.**—At the South-Western Police-court on Friday, John Hagarty, a builder, of St. Ann's-road, Stamford Hill, appeared to answer a summons for incurring a debt of £25 with intent to cheat and defraud. Evidence was given to prove that in August, 1896, the defendant carried on the business of a builder at Grand-parade, Putney, in the name of Messrs. Matthew and Co. Having a contract in hand to make some structural alterations, he applied to Charles J. Woon, a timber merchant, of Gracechurch-street, City, to supply him with timber on credit. Mr. Woon, before consenting, made inquiry into the applicant's *bona fides*, and wrote to the defendant asking if a man named Hagarty had any interest in his business. The defendant replied, signing his name as James Matthew to the letter, in the following language:—"I had a partner of the name of Hagarty some time ago, but I am the only man who represents the firm at present." Mr. Woon, feeling satisfied, acceded to the defendant's request, and from time to time supplied him with

timber of the value of £25, which had never been paid. On the 6th December, 1897, a petition in bankruptcy was presented against the defendant, and a receiving order was made in the following January, the liabilities being returned at £628 4s. 3d., the name of Mr. Woon being scheduled as one of the creditors. At a public examination the debtor admitted writing the letter, with the intention of deceiving Mr. Woon, and obtaining the timber on credit. In consequence of this admission these proceedings were ordered. Defendant was committed for trial.

**THE WAVERLEY HOTEL SCAFFOLD DISASTER,** EDINBURGH.—Sheriff Hamilton, in the Edinburgh Sheriff Court on Friday, closed the record, and allowed proof in an action at the instance of Peter M'Glynn, one of the labourers hurt at the Waverley Station accident on the 18th of March, against Messrs. G. and R. Cousin, the contractors, for £200 damages at common law, or £195 under the Employers' Liability Act, in respect of injuries he sustained. The pursuer avers that the height of the scaffold was abnormal, that it was altogether insufficient at the base for a scaffold of such height, and that it was top heavy by having placed on it a steam crane of eight tons, and a hand crane of two tons; and that the wood supplied by the defenders was of the commonest and cheapest kind. The defenders deny that the scaffold was insufficient, and hold that it fell owing to no fault of its design.

**RE-ENTRY AND THE RECOVERY OF DAMAGES.**—**MARSHALL V. MACKINTOSH.**—Judgment has been delivered by Mr. Justice Kennedy in this case. The action, which was brought against a builder to recover damages for breach of a building agreement, raised the question whether, when a landowner had exercised the power of re-entry provided by a building agreement in the event of the builder making default and has taken possession of the builder's plant and material on the premises, the landowner is also entitled to recover from the builder the actual damage he has suffered by reason of the latter's breach of contract. Mr. Justice Kennedy said that the only point which he had to decide was the question of the damages which the plaintiff was entitled to, and, as Mr. Justice Field said in "Wigzell v. School for Indigent Blind," few questions as to the principle upon which damages ought to be assessed were free from difficulty. By an agreement in writing of June 10, 1896, the defendant contracted with the plaintiff to pull down and remove certain buildings at 47 and 48, Dover-street, Piccadilly, and to build on the site a new structure, which was to be erected in carcass before December 25, 1896. Upon that being done, the plaintiff contracted to grant to the defendant a lease of the land and buildings for 80 years, from June 24, 1896, at a yearly rent of £1,100. Clause 2 provided that if the defendant made default under the agreement "he shall forfeit all benefit under this agreement, which shall thereupon cease and be determined, and all the materials and buildings on the said premises shall be forfeited to, and become the absolute property of, the lessor." Under Clause 11 there was reserved to the lessor, on default being made by the defendant, a power to re-enter upon, and to the immediate possession of, the premises and plant "without making to the lessee any allowance or compensation in respect thereof." The defendant got possession of the site on June 10, 1896, but, except that he took down and removed £200 worth of materials from the old buildings, he did nothing whatever towards the fulfilment of his contract. The fact was that he had entered upon the undertaking as a speculation without the means of fulfilling it. There being no prospect of anything further being done, the plaintiff re-entered on January 19, 1897, as he had a right to do. It was clear that the mere fact of a re-entry did not of itself exonerate the defendant from the liability to damages for breach of contract prior to re-entry (see "Hartshorne v. Watson"); but it was contended for the defendant that the effect of Clauses 2 and 11 did limit the plaintiff to such compensation as might be afforded to him by taking possession of the materials, plant, and buildings on the premises at the time of re-entry without any allowance or compensation to the defendant, and that the plaintiff could not claim damages beyond that. His Lordship could not accept that view, for that would be to read with these clauses "as and for liquidated damages," or words to the same effect, and his Lordship was not entitled to do that. It was common enough to find the insertion of such words when there was an intention of the parties so to limit the liability for a breach of the contract. Instances of this were to be found in "Reilly v. Jones," "Lea v. Whitaker," and in "Es parte Newitt—in re Garrud." In the absence of some such express words, Clauses 2 and 11 could not be construed so as to deprive the landowner of the right to prove actual damage for the defendant's failure to perform the contract; but the words in Clause 11—"without making any allowance or compensation in respect thereof"—would not operate to prevent the builder from having included in the damages any value which might exist

in the buildings, plant, &c., seized by the landowner when he re-entered. The damages must be assessed *rebus sic stantibus*, and it might be the case that, if the structure was nearly completed in carcass at the time of the re-entry, the landowner would fail to prove any substantial damage at all to flow from the breach on which he sued, as he had failed in "Oldershaw v. Holt." The question of the amount of damages had been referred to the official referee, who had made two alternative assessments. He reported that the plaintiff had, after entering, relet at the best rent he could—viz., £800 a year, after the first year, and he assessed the damages at the loss of two years' rent of £1,100 and the loss of £200 a year from June 24, 1896, at 25 years' purchase, amounting to £5,000, making in all £7,200. In the alternative, if the plaintiff was only entitled to recover damages caused by the removal of materials by the defendant and by the loss of possession from June 24, 1896, to January 19, 1897, the official referee found that the amount of such damage was £200, and one year's rent of £900 from June 24, 1896, to June 24, 1897, the earliest date at which the plaintiff was able to relet the premises. The damages must be assessed, his Lordship said, upon well-recognised principles. They must be such as flowed naturally, and in the circumstances of the case, necessarily from the breach of contract; further, they must be such damages as might reasonably be shown to have been in the contemplation of the parties when they entered into the contract. Subject to this, the plaintiff was, in the language of Mr. Justice Field in "Wigzell v. School for Indigent Blind," "entitled to have his damages assessed at the pecuniary amount of the difference between the state of the plaintiff upon the breach of the contract, and what it would have been if the contract had been performed." If the defendant had performed this contract before the date of re-entry, the old building would have been removed, and a new and valuable structure erected on the site, and if he had then failed to complete the plaintiff would have had no difficulty in getting someone to take up the undertaking on at least as profitable terms. But, as it was, the plaintiff had only been able to relet on terms involving a loss of £7,200. His Lordship could find no fault of principle in this assessment. "Oldershaw v. Holt" was the case most in point, and there it was held, it being a case of re-entry after neglect to build, that the jury might properly give a verdict on an estimate of the plaintiff's real damage, taking into consideration an increased rent secured by the agreement which he had made with a new lessee. Upon the same principle it was right in this case to consider the reduced rent which the plaintiff had been obliged to accept from a new contractor. As to the alternative assessment, his Lordship did not think that the damages could, according to legal principle, be assessed upon that basis. There would, therefore, be judgment for the plaintiff for £7,200.

**BUILDING LAWS OF BOUNDARY WALLS.**—At the South-Western Police-court, last week, Mr. Francis heard a summons against James Chapman, of 79, Sydney-street, Chelsea, at the instance of the London County Council, for erecting a building beyond the general line of frontage on the south side of Falcon-grove, Battersea. Mr. T. D. Chilvers represented the Council, and Mr. Hoskins, appeared for the defendant. It appeared that the defendant commenced to erect a washhouse at the rear of the premises, and was requested to discontinue, as the buildings extended beyond the general line of frontage. He did so, but instead erected a wall 7ft. 6in. high. Mr. Chilvers argued that the defendant had been guilty of a technical offence, as the wall was beyond the line of frontage, and in the case of "Ellis v. the Plumstead Board of Works" it was held that a wall 7ft. 6in. high was a structure within the meaning of the Act. Mr. Hoskins contended that there was no case to answer, inasmuch as the building objected to had been removed. The wall was only 7ft. high. Mr. Chilvers said, according to the decided case, a boundary wall should not exceed 6ft. 9in. high. Mr. Francis declined to say anything as to that, although he was of opinion that the wall in question was not a building within the meaning of the Act. As the defendant did erect a building in the first place, he would be fined 1s., with 2s. costs.

**STREET IMPROVEMENTS AT PUTNEY.**—At the Newington Sessions House, on Thursday in last week, before Mr. Loveland-Loveland (deputy chairman) and a special jury, the case of Marshall v. Wandsworth District Board of Works came on for hearing. This was a claim for compensation in respect of the acquirement of the leasehold premises, No. 151, Upper Richmond-road, Putney, occupied by the claimant, Mr. H. L. Marshall, job master, for the purposes of street improvements. The premises in question are held for an unexpired term of 45 years. The carrying-out of the improvement scheme would necessitate the reconstruction of the claimant's premises, by which he would be deprived of certain accommodation. An adjoining shop, let by the claimant at 7s. per week, would be completely abolished, whilst the whole of the job-master's premises would, it was alleged, be de-

preciated in value to a considerable extent through the loss of washing space, &c. Mr. Percy Henry Clarke, F.S.I. (late Ward and Clarke), 2, Lancaster-place, Strand, submitted plans, and estimated the reduction in value of the premises as a whole at £1,493, and other witnesses for the claimant were Mr. Daniel Watney, 33, Poultry, E.C., estimated loss £1,351; Mr. Samuel Walker, Moorgate-street, E.C., £1,392; Mr. A. W. Taylor, High-street, Putney, £1,482. For the Wandsworth District Board of Works, it was contended that the claim was exaggerated, and the witnesses called included Mr. Alex. R. Stenning, 121, Cannon-street, E.C., who estimated the fair amount of compensation at £623; Mr. W. Bennett Rogers, 78, Gloucester-road, S.W., £638 4s.; Mr. G. H. Brougham Glasier, 7, St. James's-street, S.W., £634 13s. 6d.; and Mr. J. C. Radford, surveyor to the district board of works, £621. The jury awarded £1,200

#### CHIPS.

The corner-stone has been laid of a new church for All Soul's parish at Captain Fold, Heywood. The building will cost about £5,000, and it will be of faced stone, with a red brick interior.

The Local Government Board having declined to entertain an application from the Cheltenham Town Council to borrow £2,740 15s. for the payment of the amount at which Mr. Robson had agreed to settle his account for architect's fees in connection with preparing plans for a kursaal and municipal offices, which have since been abandoned, the town improvement committee proposed that the amount be transferred from the water surplus account to the borough fund account. This was strenuously opposed, but was carried as a recommendation to the finance committee to transfer and pay the account.

The Marquess of Worcester has notified the tenants that the Beaufort Estates in Monmouthshire are to be sold. The property contains 26,000 acres of land, with a rent-roll of £30,000, and includes eight castles and one abbey—the famous Tintern Abbey—and 26 licensed houses.

A covered reservoir is being built for the Teignmouth Town Council on the Lansdowne-road, and will be completed within the next fortnight. Mr. Fisher is the contractor.

The Board of Trade have issued the modified and now confirmed order made by the Light Railway Commissioners authorising the construction of a railway commencing by a junction with the Helston line of the Great Western Railway at its termination and terminating at the Lizard, a distance of 11 miles 2 furlongs 9 chains. The order provides for the construction of this line by a new company, which is incorporated with a share and debenture capital of £10,000. The time allowed within which to construct the railway is five years from the 21st April, 1898.

The chancellor of the diocese of St. Alban's (Mr. A. B. Kempe, Q.C.) held a court at St. Alban's Cathedral on Tuesday, at which an application was made on behalf of Lord Aldenham for a faculty to be decreed authorising him to complete the work of restoring the cathedral high altar-screen. Lord Grimthorpe, it was stated, had had notice of the citation; but he had not entered an appearance, and the application was unopposed. The chancellor granted the faculty as prayed for.

Mr. George W. Willcocks, M.I.C.E., L.G.B. inspector, has held a public inquiry at Bacup into an application of the town council for sanction to borrow £7,100 for sewerage works.

The monthly Memorandum of the Labour Department states that employment in the building trades remains brisk, the percentage of unemployed union members at the end of the month being 1.2, compared with 1.1 for April, and 0.8 at the end of May, 1897. The furnishing trades continue busy, the percentage of unemployed union members at the end of May being 1.0, compared with 1.2 in April, and 1.1 in May of last year.

In St. Mary's Hall, Coventry, on Tuesday, Mr. G. W. Willcocks, M.I.C.E., an inspector of the Local Government Board, held an inquiry relative to the Coventry Corporation's application to borrow £33,000, for the purposes of extending the corporation's electric-light undertaking.

A singular scene was witnessed in the Court of Appeal on Monday, when Lord Justice A. L. Smith and the other judges dismissed the appeal of a plaintiff who had, by an order of Mr. Justice Bruce, been deprived of his right to sue *in forma pauperis* for sums he alleged were due to him for building repairs executed for a lady. Plaintiff, it was stated, had not only sent a letter to counsel for the defence, threatening him with an action for libel, but had imputed bad faith to Mr. Justice Bruce. On hearing the decision of the Lords Justices, he declared it was simply robbery, and announced his intention of going to the House of Lords for justice.

#### STATUES, MEMORIALS, &c.

CARDIFF.—The Marquis of Bute, under the direction of Mr. C. B. Fowler, F.R.I.B.A., is marking the grave of Llewellyn Bren in the restored floor of the Greyfriars Monastery Church, and that of Bishop Ecclescliffe in the floor (also restored) of the Blackfriars Monastery Church. In the excavation of the Greyfriars floor a large number of remains of broken stonework used in the original building was unearthed, and it was these remains which enabled Mr. Fowler to trace out the style of architecture employed. It is intended to erect a small building near the Blackfriars Church as a museum for the storage of all these relics. At the Corpus Christi festival at Cardiff Castle on the 9th inst., the altar was erected on the very site of the old high altar of the Blackfriars Church, and the tomb of Bishop Ecclescliffe, with its new memorial stone, which bears a long Latin inscription in Gothic characters, finds a place within the chancel in front of that altar. In the Greyfriars Church the new tile floor, after the original design and in the colours of the Order, has been laid by Messrs. Godwin and Son, of Lugwardine, near Hereford. The memorial stone for Llewellyn Bren, like that over the remains of Bishop Ecclescliffe, is of the hardest Portland, and both memorials were executed by Mr. Clarke, of Llandaff, under Mr. Fowler's supervision.

CROYDON.—To the Municipal Buildings have been added a statue of Archbishop Whitgift on the pedestal left vacant by the architect, Mr. William Henman, on the corner of the Corn Exchange in Katharine-street. The statue is the gift of Sir Frederick Edridge. It is of Portland stone, and is the work of Mr. J. Wenlock Rollins. The figure is in high relief, and the Archbishop is represented sitting reading a book. The figure is clothed in the fashion one is accustomed to in the ecclesiastical portraits of Elizabeth's time.

At Partick Police-court, on Friday, John M'Pherson, Squire-street, Whiteinch, having allowed several dwelling-houses in a new property at Whiteinch to be occupied before they were certified as fit for habitation by the burgh surveyor, a fine of two guineas was imposed.

It is very probable that the site of the new West Riding Asylum will be the Storthes Hall Estate. The council's requirements were five hundred acres, to be inclosed in a ring fence, twenty-five acres of plateau for buildings, and to be free from winning. The owner of the estate has been able to meet these requirements, and the surveyor to the West Riding County Council was therefore able to present a satisfactory report in regard to the land. The price asked by the owner is £39,500, or £75 an acre.

The corner stone of the new church of St. Andrew at Bishopthorpe was laid on the afternoon of St. Barnabas's Day by the Hon. Mrs. MacLagan, wife of the Archbishop of York. Mr. C. Hodgson Fowler, F.S.A., is the architect, Mr. A. W. Bowman the builder, and Mr. Bolton the clerk of works.

The town council of Warwick decided, on Tuesday, to discontinue the practice of paying the surveyor extra sums for special work, and to substitute a fixed salary of £200 a year, with a house, rent and rate free, and £20 for superintending the fire brigade. It was pointed out that it did not involve any increase of salary, as the sum is based upon the average payments of the last three years.

The urban district council of Portishead wishing to borrow £3,000 to complete the sewerage works, an inquiry was held on Tuesday at the Assembly Hall, by Mr. W. O. E. Meade-King, inspector from the Local Government Board. The money expended up to date has amounted to £13,603 1s. 7d. The increase in expenditure was caused chiefly by the failure of the original contractor, Mr. Wilkins, to finish the works. The re-letting of the works to Mr. Binn, the second contractor, added considerably to the expense. Other difficulties had occurred from rock excavation; running sands, water-logged soil, and soft spongy clay necessitating the use of concrete beds. In answer to the inspector, Mr. T. Moss Flower, the engineer, said the works were being carried on to the plans of the original scheme without material alteration, and would, it was anticipated, be finished by September next. The second contract by Mr. Binn was about 15 per cent. higher than Mr. Wilkins's, and the total cost of the work would amount to £18,500.

The traffic on the Great North of Scotland system has recently so increased, that new locomotive and other workshops are to be erected at Inverurie. The contracts include the erection of a carriage and wagon shop, 362ft. by 182ft. wide; paint shop, 242ft. by 122ft. wide; smithy and foundries, 270ft. by 102ft.; and boiler-fitting and erecting-shops, 270ft. by 263ft. While on the same area, these blocks are each separated from the other by a wide, open space, so as to provide against the spread of fire. The contracts just concluded form the first section of the work, and will occupy fifteen months in completion. The cost of the operations now sanctioned is about £40,000.

#### WATER SUPPLY AND SANITARY MATTERS.

BARMOUTH.—On Saturday new waterworks at Barmouth were formally opened by Mr. T. W. Russell, M.P., Parliamentary Secretary to the Local Government Board. These works are situated among the Merionethshire mountains, and the reservoir contains a storage of 100 million gallons, of which 52 million gallons are for the supply of Barmouth, and will supply a population of 20,000 for 104 days. The works cost nearly £30,000. At a banquet held in the afternoon Mr. T. W. Russell said that since its establishment the Local Government Board had sanctioned the spending upon sanitary work of £102,760,000. Whereas before the establishment of the central authority the expenditure upon sanitary work in the kingdom during ten years was only £2,956,000, the sum spent during the last ten years was £46,000,000.

Alderman W. Barford, of Peterborough, head of the well-known engineering firm of Barford and Perkins, and chairman of the council of Peterborough Agricultural Society, was found dead in his bed on Friday morning. Mr. Barford was for a short time a member of the old Improvement Commissioners at Peterborough, but on the incorporation of the city became a councillor, and was elected to the aldermanic dignity in 1883, in which year he was also mayor.

Memorial-stones of a Wesleyan day-school were laid at Paulton, Gloucestershire. The buildings will accommodate 300 children, are Domestic Gothic in style, and built of local stone, with freestone dressings. Mr. W. F. Bird, of Midsomer Norton, is the architect, and Messrs. Keeling and Sons are the builders.

The Oulton Union Infirmary, near Lowestoft, is being warmed and ventilated by means of Shorland's patent Manchester stoves, with descending smoke flues, and Shorland's patent exhaust roof ventilators, the same being supplied by Messrs. E. H. Shorland and Brother, of Manchester.

Through the courtesy of the contractors, Messrs. James Young and Sons, Edinburgh, the members and friends of the East of Scotland Engineering Association visited on Saturday the works in course of construction in connection with the new reservoir at Talla. The works in course of construction were inspected under the guidance of Mr. James Young and Mr. Williamson, the contractors' engineer.

Miss Hay, the daughter of the American Ambassador, opened, on Monday, as a public garden, the long-disused burial ground which lies at the rear of the Robert Browning Hall, York-street, Walworth. The garden has been prettily laid out under the direction of Miss Wilkinson, the landscape gardener connected with the Metropolitan Gardens Association. After Miss Hay had formally declared the garden open to the public, the further ceremony was performed of receiving the gift of a Doulton ware drinking fountain presented by Mr. H. Lewis Doulton, in commemoration of the fact that his father, the late Sir Henry Doulton, had, with other members of the family, been baptised and connected with the old chapel.

In the Stadtpark, in Vienna, on Monday, a monument was unveiled to the well-known Austrian painter, Hans Makart, who died there in 1884.

At the Passmore Edwards Settlement, Tavistock-place, Mr. Humphry Ward will deliver, this (Friday) afternoon and the three following Fridays, at 3.30, a course of illustrated lectures on "English Art in the Eighteenth Century." The lectures will be for the benefit of the maintenance fund of the Settlement.

The plans of the Royal Duchess Theatre, Balham, have received the approval of the London County Council, and building operations will be commenced within the next few weeks. The plans have been prepared by Mr. W. C. R. Sprague, and the building will accommodate about 2,500 persons. It is entirely fireproof, and no columns are used in the construction. The theatre is to be ready for opening next January.

Four bronze panels have been affixed to the piers of the North Bridge, Edinburgh, two as a memorial of the old bridge, and the other two in commemoration of the opening of the new. The panels are duplicated. Those referring to the new bridge have the city coat of arms at each side, and bear the following inscription: "North Bridge foundation-stone, laid 25th May, 1896, and bridge opened 15th September, 1897, by the Right Hon. Sir Andrew M'Donald, Blyth and Westland, M.M.Inst.C.E., engineers. Sir Wm. Arrol and Co., Limited, contractors. Thos. Hunter, W.S., town clerk." The other panel presents an illustration of the old bridge and a representation of the Old Town looking from the bridge to the south-west, and it bears the words: "Old North Bridge" above the picture, and below it "Founded 1763, widened 1876. Taken down."



## Our Office Table.

At Cambridge University, on Wednesday, the honorary degree of LL.D. was conferred on Mr. F. C. Penrose, M.A., F.R.S., F.R.I.B.A., F.R.A.S.; and on Sir E.J. Poynter, P.R.A., and that of D.Sc. on Mr. Charles Booth, the author of "Life and Labour of the People in London." In presenting Mr. Penrose, the Public Orator, Dr. Sandys, mentioned that the recipient of the honour was an Hon. Fellow of Magdalene College, late President of Royal Institute of British Architects, and first director of the British School of Archaeology at Athens. He was welcomed back to his University as one who had taken his degree in the Mathematical Tripos of 1842, and who had thrice rowed in the University boat-race some 57 years ago, only once among the vanquished, but twice among the victors. He was probably the only man living who had stood not only on the summit of St. Paul's, but also on that of the Olympieum at Athens. "Viro ad tantam altitudinem evecto non sine reverentia quadam in hoc templo honoris lauream nostram laeti decernimus." Sir Edward Poynter was eulogised as one whose merits had been tried and approved in a series of important public positions, as a Slade Professor, as Principal of the National Art Training Schools, and as director of the National Gallery. As a painter he had shown a profound knowledge of art, and had been distinguished for the nobility and the purity of his aims.

The Bishop of Rochester, as Acting-Dean of St. Saviour's, Southwark, appeals for £6,000 to extinguish the building debt on the fabric, all the rest of the £70,000 expended during recent years in rebuilding and refitting the nave from Sir Arthur Blomfield's plans having been met. There is, Dr. Talbot adds, further need of money to provide vestries and a choir practice room, which are positively necessary if decency and reverence are to be maintained. These, with the purchase of the site, will cost £3,000. There is need also for repairs to the tower and to the roof and walls of the choir and Lady-chapel, besides some other work, which would entail an expenditure of another £3,000, but it is not proposed to commence any of these until all the present debt is paid, nor even then until the needed sum is in hand.

MR. WILLIAM WOODWARD, A.R.I.B.A., writes to us to call attention to the threatened spoliation of one of the most beautiful portions of Hampstead Heath. Immediately adjoining the West Heath, and on its north-western margin, stands the estate of the late Sir Spencer Wells, covering an area of 36 acres, and as this land is advertised for sale by public auction, it may fall into the hands of builders, who are tempted to speculate by the announcement that these "gardens and grounds of matchless beauty present unique sites for the erection of first-class houses." As the family of Sir Spencer Wells is open to sell by private treaty, it is urged that the auction should be stayed, and the property acquired as an open space for the public by the co-operation of the London County Council, the Metropolitan Gardens Association, the Kyrle Society, and the Hampstead Vestry, or some of these bodies.

At a meeting of the court of Edinburgh University, on Monday, it was agreed to make the appointment to the Bruce and John Usher Chair of Public Health and Sanitary Science at the next meeting of the court on the 18th prox. In connection therewith, a letter was read from a benefactor of the university, who desires that for the present that his name should be withheld, intimating that he is prepared to give to the University such a sum as may be necessary, but not exceeding £10,000, to build and equip a laboratory and a class-room to be used exclusively for the teaching of public health in connection with this Chair, the site of the proposed building to be provided by the university. The court, in thanking the donor for the munificence of his gift, resolved to record their gratification that it had taken a form which enabled the University to extend its usefulness by the creation of an institute which was urgently required for promoting the study of public health.

The Dean of Bristol, Dr. Pigou, states that at the last meeting of the Cathedral Restoration Committee it was decided that the restoration be proceeded with, and that such portions of the external fabric as require immediate attention shall be taken in hand at once. The foreman of

the works attended the meeting, and assured the committee that certain portions of the fabric are in a most ruinous and even unsafe condition. The following, therefore, were selected out of the six portions which require restoration:—The Berkeley chapel and roof, estimated cost, £820; the south choir aisle, £450; and the Newton chapel, £300. These works are simply for external repairs to the south-eastern portion of the Cathedral, and the sum required, inclusive of the existing debt of £1,000, is £2,570. Towards this sum about £130 has already been promised.

The Municipal Art Society of New York, after five years of existence as a voluntary association, has been incorporated, and, under its new and official constitution, is enabled to institute and control competitions for works of art to adorn the city, for the execution of which the society itself does not pay. In pursuance of these new powers, it proposes to invite at once a competition for designs for a city street-lamp, awarding prizes from its own funds, but leaving the execution of the successful design to the municipal street-lighting department. This competition is to be followed by others, including designs for park benches and drinking fountains.

Up to the close of March this year, 3,256 houses had been connected with a new sewage system at Cape Town. The total length of sewers laid at the same date was 30 miles 482 yards. The total amount expended to the same date, including preliminary expenses and extra work, was £167,628.

The buildings which have been recently completed in Newgate-street, Chester, for the Conservative and Unionist Club, at the expense of Mr. Yerburgh, M.P., for the city, were opened on Saturday. The premises contain a billiard room with two tables, reading, card and smoke rooms, lavatories, &c., and there is also attached an assembly-hall, which will be available for political and social meetings. The design was that of Mr. H. Beswick, of Chester, county architect, under whose superintendence the work has been carried out.

The corporation of Douglas, Isle of Man, have decided to increase its water supply by the construction of a reservoir at West Baldwin, capable of containing 300 million gallons. The holding capacity will be six times that of Clype Reservoir. It will take five years to complete the new scheme, which will place Douglas, with regard to its water supply, in as good a position as any borough of the same size in the United Kingdom.

The week at the Tokenhouse-yard Mart has proved a busy one. Though large estates were not much in request, there was a brisk demand for small-class residential properties, ground-rents, and investments generally. Building land was not quite so actively in demand, but about £800 per acre was paid for 92 acres at Southampton.

On Wednesday week the formal opening took place of the New-street Congregational Hall at Welshpool. Mr. F. D. Ward was the architect, and the builder was Mr. Evan Davies. It includes an assembly-room, with accommodation for about 300 persons, with a committee-room raised a little above the floor of the room, and having folding doors, and this forms a main platform for public meetings. There are also a cloak-room, and a scullery, with boilers, &c.

An elaborate memorial brass has just been set up in Cherry Burton Church, Yorks, in memory of the late Captain Cecil Fowler Burton, Royal Fusiliers, eldest son of General Fowler Burton, C.B., J.P., who died at Mhow, Central India. The memorial "is erected by his brother officers who served with him in the regiment, in memory of a zealous soldier and a steadfast friend." It was the work of Messrs. J. Forsyth, of Finchley-road, Hampstead.

The outcome of the public competition for a clock-tower at Penang Straits Settlements has been that the municipal engineer's design was chosen by the municipal commissioners, and he was awarded the prize for the best design. Mr. Barnett, a private engineer practising in the Island, has been appointed to supervise the building of the tower.

The Occasional Sunday Ramblers' and North Staffordshire Clarion Field Club visited Moreton Old Hall on Saturday last, and were joined by contingents of other Socialists from Crewe, Leek, and Macclesfield, as well as the Pottery towns, the gathering exceeding 200. After Astbury Church had been visited, the party took tea in the Old Hall. The leader for the day, Mr. Lerner Sugden, F.R.I.B.A., of Leek, then read some notes on the architectural history of this famous and comely pile, now fallen on evil days of "restoration" and neglect, making caustic references to the present social system with its foul fungoid growths of modern jerry-builders, &c.

## MEETINGS FOR THE ENSUING WEEK.

SATURDAY (To-morrow).—London Architectural Association. Visit to Paddockhurst, Sussex, the residence of Sir Weetman Pearson, Bart. Train from London Bridge Station (L.B. and S.C.) to Three Bridges 2.25 p.m.

Northern Architectural Association. Visit to Durham Cathedral and County Council Offices.

Liverpool Architectural Society. Visit to Thornton Manor (the seat of Mr. W. H. Lever) and Sunlight Village. Book from Landing-stage. 2 p.m.

MONDAY.—Royal Institute of British Architects. Presentation of Royal Gold Medal to Professor Aitchison, R.A., President. 8 p.m.

WEDNESDAY.—Society of Arts. Conversation at the Natural History Museum, Cromwell-road, S.W. 9 p.m.

## CHIPS.

A parish-room is in course of erection at Willand, the contractors being Messrs. Chick and Bradbeer.

A new Conservative club is being erected at Epsom, and special consideration has been given to the ventilation, which will be carried out on the Boyle system.

A large clock with quarter chimes has just been erected in the parish church of Uppingham, Rutland, by Messrs. John Smith and Sons, Midland Clock Works, Derby.

A private house at the corner of Carr-street and Little Coleman-street, Ipswich, has been converted into business premises. Mr. G. W. Leighton, Princes-street, Ipswich, was the architect, and Mr. Friend, of Sedan-street, in the same town, the builder.

A new post-office is about to be built in Hill-street, Newry, at a cost of about £5,000, from plans prepared in H.M. Office of Works. The contractor is Mr. Alexander Wheelan, of Newry.

The urban district council of Grange-over-Sands have adopted plans, and are making application to the L.G.B. for powers to borrow £10,000 to carry out a sewerage scheme and a promenade for the foreshore. The new sea-wall will reclaim 5½ acres of land, which will be used as a recreation ground.

The question of the reconstruction of Regent Bridge was under the consideration of the Aberdeen Harbour Board on Monday. On the recommendation of the works committee, it was agreed to proceed with the erection of a new bridge, according to the plans of the harbour engineer, and approved by Mr. Wake, C.E., the consulting engineer. The estimated cost of the bridge is £49,740.

Mrs. Diana Margareta Moffatt, the relict of Mr. W. B. Moffatt, architect, who was for a considerable period senior partner with the late Sir Gilbert Scott, at Spring Gardens, died on the 4th inst. at Roche, Cornwall, after a prolonged illness. Mrs. Moffatt was in her 73rd year.

At their meeting on the 13th inst., the Establishment Committee of the Malens and Coombe Urban District Council approved of the plans, &c., prepared by Mr. T. V. H. Davison, of New Malden, for the new public offices, central fire station, stabling, mortuary, and post-mortem room.

At the Hanley County Police-court, on Monday, Mr. C. Daniel, clerk to the Stoke Rural District Council, applied under the Housing of the Working Classes Act, 1890, for an order against Richard S. Topham, of London, the owner of ten dwelling-houses at Topham's-row, Brookhouse Green, Bucknall, empowering the council to close those houses, they being in a "state so dangerous, or injurious to health, as to be unfit for human habitation." The defendant did not appear in person, or by representation. Mr. Lerner Sugden, surveyor to the rural district council, described the deplorable, dilapidated condition of the dwellings, and defendant was fined £50, and ordered to pay another £7 costs.

The Prince of Wales visited Reading on Saturday for the purpose of opening the College, which has grown out of the University Extension movement. The first home of the college, opened only so lately as 1892, was an ancient building, formerly part of the Hospital of St. John, attached to the abbey of Reading. The accommodation was soon found to be insufficient for the increasing number of students. Mr. Herbert Sutton, chairman of the council, purchased the vicarage of St. Lawrence, adjoining the Hospitium, and the acquisition of this property enabled necessary enlargements to be made on the suggestion of Mr. S. Slingsby Stallwood, the architect, including the building of a dairy institute. The cost of the college properties and buildings has exceeded £20,000.

A new infant school, which has just been added to the parochial schools of Holy Trinity, Taunton, was opened on the 8th inst. The architect is Mr. G. C. Strawbridge, and the builder Mr. Wm. Rendell, both of Taunton.

Trade News.

WAGES MOVEMENTS.

**BERWICK.**—The plasterers of Berwick, after giving a week's notice, came out on strike on Monday for a rise of 1d. per hour in their wages. The men are at present paid 7d., and the masons 8d. The plasterers ask for the same rate of pay as the latter. The building trade at present is brisk in Berwick. The joiners have also asked for an advance of wages to take effect in July.

**MANCHESTER.**—The strike of stonemasons, which began on the 15th ult., remains unsettled. The operatives' notice, requiring certain alterations of existing rules and the addition of some new rules, expired on that date. The men were informed that the alterations and additions could not be accepted, and they therefore ceased work. The hon. secretary of the Masters' Association states that the masons had been working 49½ hours per week, and one of their demands was for a 47-hour week, with walking time night and morning, and an advance of a penny per hour (from 9d. to 10d.) The masters offered a halfpenny per hour advance. The men also take exception to a number of rules governing their employment; but the principal object being to the employment of other than masons on stone-working machines. The men further protest against the importation of worked stone into Manchester or the taking of worked stone outside Manchester, limiting the work to a five-mile radius. They also seek to restrict the number of apprentices. The members of the Builders' Federation have already discharged 50 per cent. of the masons in their employment, and in the event of the strike not being settled soon they threaten to lock out the whole of the masons in the federated districts. The Federation, which has only recently been formed, includes the master builders of Liverpool, Manchester, Accrington, Ashton-under-Lyne, Birkenhead, Blackburn, Blackpool, Bolton, Burnley, Bury, Chorley, Darwen, Lancaster, Leyland, Longridge, Morecambe, Oldham, Preston, Radcliffe, Rochdale, Stockport, Wallasey, Warrington, and other towns.

**NEWPORT, MON.**—A further complication in the building trades dispute at Newport occurred on Saturday when the members of the Society of Plasterers stopped work. The ground of cessation is that the men object to imported non-society men being employed.

**NUNEATON.**—The local branch of the Amalgamated Society of Carpenters and Joiners have come to an understanding with a majority of the employers in that town, whereby the standard rate of wages from next October till 1900 will be 8d. per hour.

**ULVERSTON.**—The whole of the wallers in Ulverston, numbering over 40, have struck work after a week's notice, the masters having refused to concede an advance of 1d. per hour. The employers have offered an advance of ½d., but this has not been accepted.

CHIPS.

The Tottenham School Board have again deferred consideration of the plans selected for the new offices. The Board have decided to advertise for tenders for building new schools at Woodlands Park, and to readvertise for tenders for building Glasgow Alexandra schools.

The foundation-stone of the Leather Department of the Yorkshire College, at Leeds, was laid on Monday. The new buildings will contain, on the ground floor, a laboratory fitted with machinery for leather finishing, and workrooms for tanning and dyeing. On the first floor there will be research and bacteriological laboratories, and the second floor will contain store-rooms and drying accommodation, and probably a museum. The architects are Messrs. Alfred Waterhouse and Sons.

Mr. J. L. Radfern, Hanley, has been appointed deputy city surveyor of Carlisle.

Mr. Mould, the Newington librarian, is getting together an exhibition of the works of George Tinworth, the sculptor, who, it will be remembered, was born in Walworth.

At the first meeting of the newly-elected Strand District Board of Works, Mr. G. Roes proposed the re-election as chairman of Mr. Walter Emden, J.P., P.S.A., whose courtesy, impartiality, and dignified conduct in the chair during the past twelve months, he remarked, were appreciated by all his colleagues, who were also sensible of the very valuable services rendered to the board by the professional skill and knowledge of that gentleman as an architect and surveyor. Mr. Dunscombe seconded the resolution, which was supported by Mr. Gamble and Mr. Cox, the latter remarking that Mr. Emden had devoted more time to the business of the board than any other member connected with it. The resolution was carried unanimously.

Col. Arthur Clifford Alexander, R.E., late colonial engineer and surveyor-general of the Straits Settlements, died on the 9th inst. at Rosemeath, Rushbrooke, Co. Cork, aged 54 years.

The Cowlyd Water Board, at their last meeting, held at Colwyn Bay, appointed Mr. T. T. Marks, C.E., as consulting engineer, in the illness of Mr. T. B. Farrington, C.E.

The Duke of Devonshire will visit Manchester on Wednesday next, the 22nd inst., to open the new Christie Library at Owens College, and to lay the foundation stone of the Whitworth Hall.

A large music-hall in Dewsbury, known as Harte's Amphitheatre, was totally destroyed by fire on Sunday. It gave sitting accommodation for 2,000 persons, and should have been sold by auction on the following Wednesday for the benefit of the creditors.

At Tuesday's meeting of the Birmingham City Council, the Lord Mayor submitted the recommendation of the General Purposes Committee as to the purchase by the council of the undertaking of the Birmingham Electric Supply Company (Limited) at the price of £420,000, and authorising the committee to take the necessary steps for the promotion of a Bill in Parliament to authorise the purchase. There was no opposition to the scheme and the recommendation was agreed to.

The corner-stone of the English church at Lucerne was laid, on Tuesday, by Mr. F. R. St. John, minister-plenipotentiary at Berne. The edifice is being erected from the designs of Mr. F. R. Farrow, F.R.I.B.A., of the firm of Colson, Farrow, and Nisbett, architects, Winchester and London.

Colonel W. R. Slacks, an inspector of the Local Government Board, held an inquiry at the Institute, King's Heath, on Friday, in reference to an application of the King's Norton Rural District Council for sanction to borrow £1,350, for the purchase of land as the site of a new depot and stores.

A new board school at Snape, near Pickering, was opened on the 9th inst. The school accommodates 75 scholars, and has been built to plans by Mr. C. H. Channon, architect, of Malton, at a cost of between £700 and £800. Mr. Martindale, of Pickering, was the contractor. A new school is also to be built for Pickering, at an estimated cost of £1,500.

The freehold ground-rent of £282 per annum secured on the premises occupied by Messrs. Doulton and Co. till 1939 was sold by Messrs. Arber, Rutter, and Waghorn by auction on Friday, for the sum of £16,000, to the British Empire Mutual Life Assurance Company. This represents over 73 years' purchase, and pays 1½ per cent.

SZERELMEY STONE LIQUID. THE TEST OF TIME.

Over Forty Years' General Experience has proved that

SZERELMEY STONE LIQUID, Absolutely Waterproofs and Preserves BRICKS, STONE, CEMENT, PLASTER, STUCCO, &c.

Adopted by Governments and Public Bodies throughout the world.

SZERELMEY & CO., ROTHERHITHE NEW RD., S.E.

W. H. LASCELLES and Co., 121, Bunhill Row, London, E.C.

TELEPHONE No. 270.

HIGH-CLASS JOINERY.

LASCELLES' CONCRETE.

Conservatories & Greenhouses.

WOODEN BUILDINGS.

BANK, OFFICE, & SHOP FITTINGS.

CHURCH BENCHES & PULPITS.

ESTIMATES GIVEN ON APPLICATION.

IS THE ELECTRIC LIGHT REALLY DEARER THAN GAS?

A large number of replies to the above query from actual users will be sent post free on application to the

COUNTRY HOUSE SPECIALISTS, Messrs. DRAKE & GORHAM, 66, VICTORIA STREET, WESTMINSTER, LONDON, S.W.

LATEST PRICES.

IRON, &c.		Per ton.	Per ton.
Rolled-Iron Joists, Belgian	.....	£6 0 0	to £8 10 0
Rolled-Steel Joists, English	.....	6 10 0	7 0 0
Wrought-Iron Grids Plates	.....	5 15 0	8 10 0
Bar Iron, good Staffs	.....	7 0 0	8 0 0
Do., Lowmoor, Flat, Round, or Square	.....	17 0 0	17 5 0
Do., Welsh	.....	5 15 0	5 17 6
Boiler Plates, Iron—			
South Staffs	.....	7 17 6	8 5 0
Best Snedshill	.....	10 0 0	10 10 0
Angles 10s., Tees 20s. per ton extra.			
Builders' Hoop Iron, for bonding, &c., £6 15s. 0d. per ton.			
Builders' Hoop Iron, galvanised, £15 10s. 0d. per ton.			
Galvanised Corrugated Sheet Iron—			
No. 18 to 20.	No. 22 to 24.		
6ft. to 8ft. long, inclusive gauge	.....	£10 15 0	to £11 0 0
Best ditto	.....	11 5 0	11 10 0
Cast-Iron Columns	.....	£8 0 0	to £8 10 0
Cast-Iron Stanchions	.....	6 0 0	8 10 0
Rolled-Iron Fencing Wire	.....	7 0 0	8 0 0
Rolled-Steel Fencing Wire	.....	7 6 0	7 10 0
Galvanised	.....	10 10 0	11 10 0
Cast-Iron Sash Weights	.....	4 0 0	4 2 6
Out Clasp Nails, 3in. to 6in.	.....	8 15 0	9 15 0
Out Floor Brads	.....	8 10 0	9 10 0
Wire Nails (Points de Paris)			
0 to 7	8 9 10 11 12 13 14 15	B.W.G.	
8/6	9/0 9/6 10/3 11/0 12/0 13/0 14/9 16/9	per cwt.	
Cast-Iron Socket Pipes—			
3in. diameter	.....	£5 10 0	to £5 15 0
4in. to 6in.	.....	5 5 0	5 10 0
7in. to 24in. (all sizes)	.....	4 15 0	5 0 0
[Coated with composition, 2s. 6d. per ton extra; turned and bored joints, 6s. per ton extra.]			
Pig Iron—			
Cold Blast, Lilleshall	.....	105s.	to 110s.
Hot Blast, ditto	.....	57s. 6d.	to 62s. 6d.
Wrought-Iron Tubes—Discount off Standard Lists f.o.b.			
Gas-Tubes	.....	75p.c.	Fittings 77p.c.
Water-Tubes	.....	70	72s
Steam-Tubes	.....	62½	65
Galvanised Gas-Tubes	.....	60	62½
Galvanised Water-Tubes	.....	55	57½
Galvanised Steam-Tubes	.....	45	47½
10cwt. casks. 5cwt. casks.			
Sheet Zinc, for roofing and working up	.....	£22 10 0	to £23 10 0
Sheet Lead, 3lb. per sq. ft. super.	.....	15 7 6	16 7 6
Pig Lead, in 1cwt. pigs	.....	14 15 0	15 15 0
Lead Shot, in 28lb. bags	.....	17 10 0	18 10 0
Copper Sheets, sheathing and rods	.....	62 10 0	63 10 0
Copper, British Cake and Ingots	.....	51 15 0	52 15 0
Tin, Straits	.....	69 15 0	70 15 0
Do., English Ingots	.....	72 10 0	73 10 0
Spelter, Silesian	.....	18 0 0	19 0 0
TIMBER.			
Teak, Burmah	.....	£13 0 0	to £14 5 0
Bangkok	.....	9 5 0	13 15 0
Quebec pine, yellow	.....	2 18 0	4 18 0
Oak	.....	3 15 0	5 0 0
Birch	.....	3 0 0	4 13 6
Elm	.....	4 3 0	5 3 0
Ash	.....	3 18 0	5 3 0
Dantaic and Memel Oak	.....	2 0 0	3 0 0
Fir	.....	2 13 0	4 3 0
Wainscot, Riga p. log	.....	4 18 0	5 18 0
Lath, Dantaic, p.f.	.....	4 10 0	5 10 0
St. Petersburg	.....	5 0 0	6 10 0
Greenheart	.....	8 0 0	8 10 0
Box	.....	4 0 0	15 0 0
Sequoia, U.S.A. per cube foot	.....	0 1 8	0 1 10
Mahogany, Cuba, per super foot			
lin. thick	.....	0 0 5	0 0 6½
Honduras	.....	0 0 4½	0 0 6½
Mexican	.....	0 0 4	0 0 5
Cedar, Cuba	.....	0 0 4	0 0 4½
Honduras	.....	0 0 3½	0 0 4½
Satinwood	.....	0 0 5	0 1 0
Walnut, Italian	.....	0 0 3	0 0 7
Deals, per St. Petersburg Standard, 120—12ft. by 1½in. by 1½in.—			
Quebec, Pine, 1st	.....	£18 15 0	to £21 15 0
2nd	.....	13 5 0	15 15 0
3rd	.....	10 15 0	9 5 0
Canada Spruce, 1st	.....	10 15 0	12 5 0
2nd and 3rd	.....	8 5 0	9 5 0
New Brunswick	.....	7 5 0	8 5 0
Riga	.....	7 5 0	7 15 0
St. Petersburg	.....	9 5 0	13 5 0
Swedish	.....	9 15 0	16 5 0
Finland	.....	8 15 0	9 5 0
White Sea	.....	9 15 0	16 5 0
Battens, all sorts	.....	5 0 0	18 0 0
Flooring Boards, per square of lin.—			
1st prepared	.....	£0 9 6	to £0 17 9
2nd ditto	.....	0 8 0	0 13 6
Other qualities	.....	0 6 3	0 7 0
Staves, per standard M.—			
Quebec pipe	.....	—	—
U.S. ditto	.....	£35 0 0	to £42 10 0
Memel, cr. pipe	.....	220 0 0	230 0 0
Memel, brack	.....	190 0 0	200 0 0
OILS.			
Linseed	.....	per ton £17 0 0	to £17 10 0
Rapeseed, English pale	.....	24 10 0	25 10 0
Do., brown	.....	20 0 0	24 0 0
Cottonseed, refined	.....	16 5 0	16 15 0
Olive, Spanish	.....	32 10 0	33 0 0
Seal, pale	.....	20 0 0	21 5 0
Cocunut, Cochin	.....	29 0 0	29 10 0
Do., Ceylon	.....	24 0 0	24 5 0
Palm, Lagos	.....	23 15 0	24 0 0
Oleine	.....	18 15 0	19 15 0
Lubricating U.S.	.....	per gal. 0 6 3	0 7 6
Petroleum, refined	.....	0 4 4	0 5 4
Tar, Stockholm	.....	per barrel 1 0 0	1 5 0
Do., Archangel	.....	0 19 6	0 15 0
Turpentine, American	.....	per ton 23 15 0	24 0 0

# THE BUILDING NEWS

## AND ENGINEERING JOURNAL.

VOL. LXXIV.—No. 2268.

FRIDAY, JUNE 24, 1898.

### COMPETITION DESIGNS FOR FEVER HOSPITAL AT CARSHALTON.

THE three designs that have been chosen by Mr. Henry Currey, F.R.I.B.A., the assessor, as entitled to the premiums of £150, £100, and £50 respectively, for the proposed fever hospital at Carshalton, now on view at the offices of the Metropolitan Asylums Board, show three different arrangements of the sets of isolated cottages or pavilions with the staff accommodation attached. The ten competing architects who submitted designs had to conform to several conditions. No fewer than 720 patients had to be distributed in 30 double cottages for 24 patients each, or 12 in one cottage, and these had to be arranged in groups so that five double cottages were under one sub-matron. Each double cottage had to provide for one separation room for two beds, and the space for each patient in the dormitories was to give 920c.ft., or not less than 96sq.ft., allowing 80ft. wall-space to each bed. In the day-rooms 60sq.ft. floor-space had to be provided. A bedroom for house mother, a scullery, safe for food, linen-cupboard, recess for brooms, and bath and ablution-room were required for each of the cottages.

In addition, an adjacent building to each five cottages, for the staff, was to contain a sub-matron's sitting and bedroom, &c., a sitting and mess-room for three night-assistants, and seven maids' rooms, and cubicles, &c. Isolation wards for 80 cases with 44 beds and separate wards for 36 beds; also administrative block, containing the usual rooms for medical officers, superintendent, dispensary stores, and kitchen offices and matron's and servants' quarters had to be embraced; and provision was to be made for laundry and houses for medical superintendent, steward, engineer's workshops, &c.

The plans marked with letter "A," by Messrs. Treadwell and Martin, which have been awarded the first premium, is on the *échelon* principle. The thirty double cottages are arranged along three rows of covered corridors placed obliquely to a central axial corridor running north and south. The north end is terminated by the central administrative block, five double cottages are placed along one of the six *échelon* corridors which run from the centre stem, and these have each the day-rooms with north and south windows, with two return wings or dormitories with windows east and west, the two airing-courts being between, so that the walls are freely exposed to sunshine, also the airing-courts, but sheltered from north and east. The staff blocks are attached to each group or corridor of five cottages. Looking at the plans of each pair of cottages, which are U-shaped, we find the authors have fairly complied with the requirements, the two day-rooms at each end of the main block with its own entrance and scullery, lighted on both sides; each is 36ft. by 20ft., and in the centre is the separation room, with distinct entrance, 20ft. by 13ft. for two beds, and lighted by windows at both ends. On the airing-yard side a covered verandah runs along the south side of day rooms. At the end of each pair is a house-mother's room and linen-closet. Inclosing the airing-courts on two sides are the dormitories, each for 12 beds, 50ft. by 20ft., or six beds on each side. The bath, ablution-rooms, &c., are isolated, and project at the north end of each cottage. An alternative plan shows two-story cottages, L-shaped; the day-rooms are at the ends of each wing, 36ft. by 20ft.,

lighted by good bay windows; at the corner is the entrance-hall, stairs, and scullery, with a separation-room, 26ft. by 13ft. for each cottage. Above, the dormitories, 50ft. by 20ft., have six beds on each side, with windows between, a house-mother's room, and to each is an isolated bath, lavatory, &c., projecting from each ward. We prefer the first plan. The alternative plan shows the cottages arranged along three parallel corridors. The isolation blocks in both are placed at the south end of the central corridor. The administration block at the north end has long corridors and lacks compactness and concentration. The elevations are simply treated and effective, brick being used with a little variety in the outlines of roof and parapet.

The second selected set of plans, "J," by Messrs. Pennington and Sons, Norfolk-street, adopt a segmental distribution of cottages. Four lines of covered corridors, with radial or cross corridors, give access to the three groups of ten cottages. The slight curve adopted gives a very desirable amount of sunlight to the first group on the eastern end, the dormitories and day-rooms facing to a large extent south-east. The day-rooms are at the ends lighted by large bay windows, and each room is 36ft. by 20ft., with entrance, scullery, bath, and mother's room convenient to each dormitory of 12 beds, which measures 43ft. by 20ft. These dormitories are end to end, and connect the end wings or day-room blocks. On the north side, isolated and ventilated, is the bath and closets block, and on the south side the separation room for two beds. As these blocks are between the dormitories, they are available for both. The arrangement is simple and probably less costly than the other designs. Each block of double cottages forms an elongated  in shape.

The third plan, "J" (Messrs. Newman and Newman, of Tooley-street) is more elaborate in arrangement. The authors' scheme shows a sort of amphitheatrical plan round a centre garden. The lines of corridors form a large semicircle on the eastern side of site, round which are four lines of parallel corridors with radiating ones dividing into three groups, connecting them. The double cottages are placed axially north and south between these corridors, so that the dormitories of each pair-block get the full sunlight on the east and west walls. In the centre is a garden with water-tower, and the administration offices are in a line with it on the west side, and the isolation block on the east side. The staff blocks are placed in connection with each group and within easy access. The plan of each double cottage shows a day-room 31ft. by 23ft. with bay window, with mother's room attached at each end, with dormitories axially end to end between. The arrangement of separation room and closets and lavatories, semi-detached, resemble the last described; the dormitories are well lighted on both sides between the beds; the entrance to each cottage is at the extreme end, with a scullery, bathroom, and other necessary requirements. The plan for isolation pavilion shows a ward 36ft. by 22ft. for six beds, with verandah, and the nurses' rooms are convenient. The alternative scheme is less satisfactory. The isolation pavilions are to provide 44 beds—34 beds for families and children, and 10 for men, and separate wards for 36 beds distributed for a different number of beds. Each has to have a floor space of 156ft. super., or 12ft. wall-space. The authors of these plans appear from our general examination of them to have conformed to the requirements of the managers. The blocks are well isolated and exposed to sunlight and air; the airing courts are, in one set at least, well protected from north and east winds. The design placed first is certainly treated in a plain and substantial manner without unnecessary features.

### MODEL SPECIFICATIONS.—XVIII.

MASON.

IN our present article we give examples and clauses for several features of stone buildings that are not often dealt with. Take, for instance, a stone bay window—the builder is generally referred to the contract drawings or detail; but unless these are carefully figured, much is left to the mason. The ordinary bay window angle mullion is sometimes cut out of slab stone, and put together very much like a boxed marble fire-place jamb with vertical joints; or the mullions  $4\frac{1}{2}$ in. thick, are sawn out of a solid stone, and made to appear as if they were solid. We are alluding to the common mode adopted by speculative villa-builders. The only proper mode of working them is to treat them as solid mullions or pilasters, each piece being cut out of the solid prism of stone, and to sink the splayed or return faces and reveal, and to form rebate for frames.

The mullions ought to be dowelled to the sill with copper or slate dowels, and each length ought to be fixed in the same manner and bedded or pointed in stone-dust mortar. The extreme dimensions of angle mullions ought to be given if a large-scale detail is not supplied. The transoms, also the bonding of the jambs, how the beds are to be worked, and the heights of each stone should be specified. Gothic mullions are seldom described as they ought to be. The size of finished mullions, their height, if moulded or chamfered, whether to show fair inside, and whether they are to be glazed with lead lights, with grooves or rebates for the same, or if to be rebated for iron frames are points to be named. We give a few clauses for these. For bay windows, the angle mullions may be worked as shown, either as *a* or *b*; the latter shows the pilaster placed anglewise between the two faces. If the pilaster is carved on face or panelled only, it should be shown by a sketch or detail, Fig. 3, and referred to. One important point is the jointing of sills. Unless they are very carefully bedded, the slightest settlement of jambs or mullions will cause them to crack, if in one long piece. To avoid this, the vertical joints of long sills should be placed beneath the mullions or in line with the reveals, if possible. Though a joint in the centre of a light is objected to, it is often seen in old buildings.

The practical construction of stone domes has received less attention than the theory, and there are few textbooks or precedents for specifications, and the architect often refers to this item in a very general and inadequate manner. We shall give a clause or two. The stones of the several courses should be worked with accurate beds and joints from properly set out full-size drawings, the templates for the bed-mould and joint-mould of each stone in every course being correctly prepared. The details should show the number of courses, and particular care is necessary to break the vertical joints, and to cramp the stones, or dowel them. If the dome is large, or a lantern surmounts it, provision should be made for iron bond or linked bars, at the springing of the dome. We illustrate, Fig. 4, a lantern and cupola of dressed stone as an example. We also give a few sketches for Gothic work. The examples of mullions and jambs (Figs. 5 and 6) one plain splayed, the other moulded, with the plane of mullions recessed, are commonly met with. The other figures (7 and 8) illustrate bases for Gothic buildings, and a gable showing how the "springers," "kneelers," and apex stones are worked.

44. *Two-Light Window, Moulded and Carved* (see sketch 4, p. 841).—The two (or three) light windows of ground story to have moulded sills, architraves, and mullions, as shown in detail. The side jambs or architraves to be moulded according to section, to be in one double sun-faced stone, 15in. in width by 12in. in thickness or bed (or be in two stones), and to be three or four courses of ashlar in height, bonded to wall

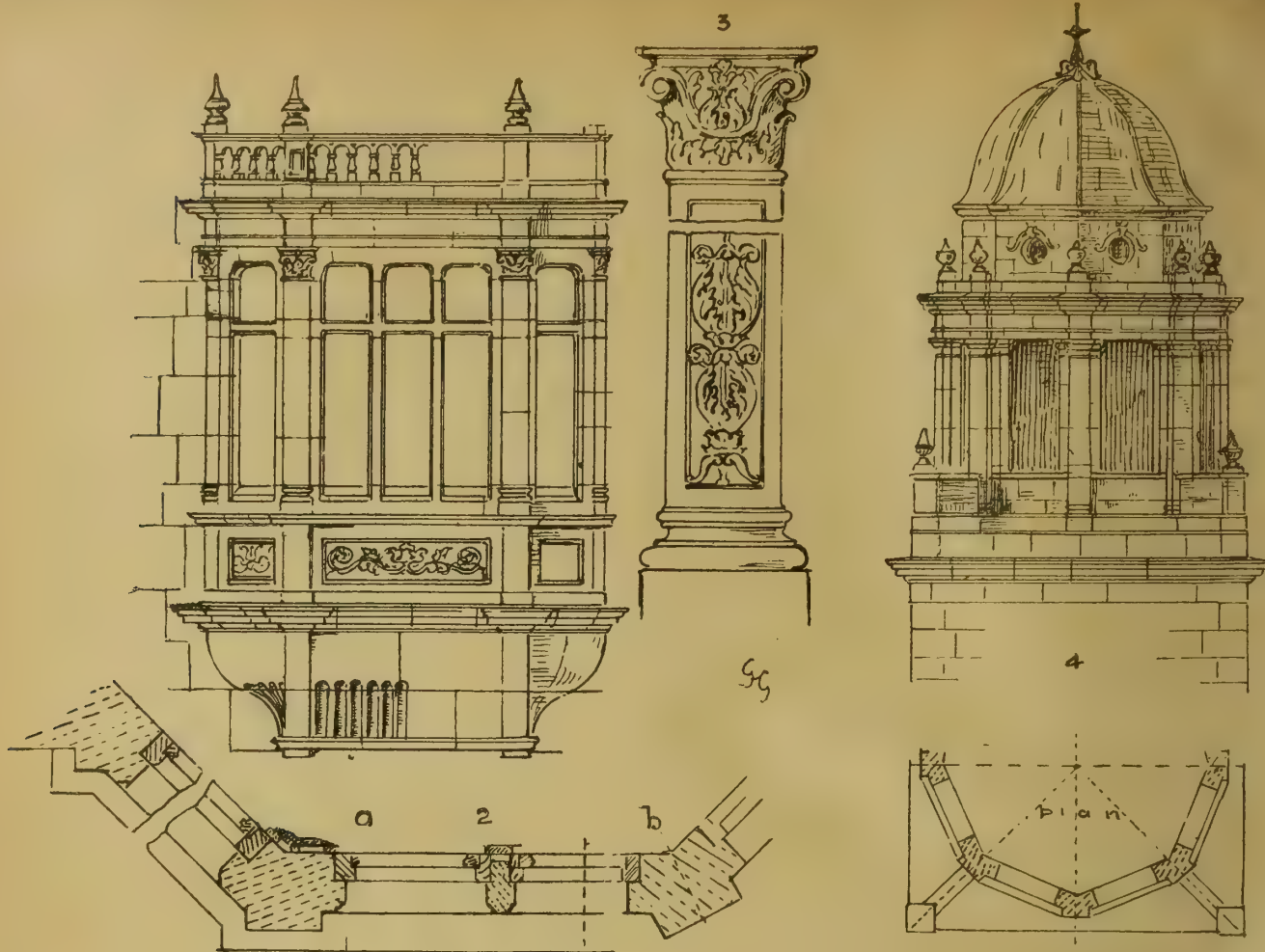

and dowelled to sill, and to have head to match. The centre mullion (see sketch) to be worked out of a stone 7in. (or 8in.) by 5in. in section, extreme dimensions, with moulded base, panelled pedestal and pilaster, and capital out of two blocks (or one). The base to be dowelled with slate or copper to the seating of sill, and the capital to be dowelled to the transom; the upper mullion above to be a carved baluster, also dowelled to head, and both to be rebated for wooden frame. Or—

The window to project, with the two projecting mullions moulded as shown, and to be worked as pilasters plain (or panelled and carved) in one (or two) stones, rebated to wooden frame, with recessed mullions and transom, and entablature over. The mullions to be dowelled to seatings of sill, and the beds to be arranged every three (or more) courses of ashlar and well bonded to wall.

45. *Bay Windows*.—The jambs and mullions to be of selected Portland (Bath or other) stone, and to be executed according to detail. Each face of mullion to be 9in. (or 12in.) with  $4\frac{1}{2}$ in. (or 6in.) reveals, wrought out of solid blocks of the whole height (or in two or three pieces) rebated (or state if frames to be moulded on edge or otherwise enriched). There are to be no vertical joints; the upper and lower end of mullions to be dowelled with slate (or copper) dowels to seating of sill and window heads. Or—

The bay window to be constructed, as shown (see sketch 1), on two courses of moulded corbeling with returned ends bonded into wall. The stones to be in one (or two or more) lengths, the lower course tailed or pinned into wall at least 9in., and to be cramped together (if of several stones) with slate dovetail cramps 10in. long (or dowelled), with the lower face enriched by channels or flutings. The cornice (12in. by 6in.) and carved dado over to be as shown, the cornice dowelled to the upper course of corbel; the dado, 6in. thick, dowelled to base, and to have carved panels. The sill to be 12in. by 6in., moulded on outer edge mitred round mullions, sunk, weathered, and throated with stools left for mullions. These are to form pilasters carved on face, and to be worked out of solid stones 13in. by 10in. in two (or three) pieces; each pilaster to have a moulded base and carved capital; the sunk panel enrichment to be modelled to the architect's approval. Each

pilaster to be secured by metal dowels to the sill and head, and these, as well as the entablature, are to be bonded to the wall. The mullions to be formed in two pieces, dowelled to the transom, sill, and head. The cornice to be mitred as shown over pilasters, and to be surmounted by a plinth, balustrading, and capping, according to details, with all necessary lead plugs, dowels, and cramps.

46. *Turrets*.—The turrets to be built of Portland stone in courses to bond with ashlar (rubble or brickwork) breaking joints on solid stone corbels in three (or four) courses, the lower course to tail into wall at least 12in. (or 18in.); (if necessary the stones in each course to be cramped with copper cramps, 12in. long and 2in. by  $\frac{1}{2}$ in.), run with lead.

47. *Lanterns and Cupolas*.—The turrets to be crowned with lanterns (or cupolas) of stone (see sketch), worked fair inside and outside, and the stones to be dowelled (or cramped) together with copper dowels (or cramps), run with lead or sulphur. Or—

The turrets to have conical roofs or cappings of five or more courses of wrought stone, the upper course worked out of solid stone, with level and true beds dowelled together with copper dowels (or each course to be plugged with lead at the joints), the shafts and finials to be secured by copper spindles,  $1\frac{1}{2}$ in. diameter. Or—

48. *Stair Turrets*.—The circular (or octagonal) stair turrets to be constructed of solid stone blocks, worked to level beds and square joints, breaking joint; worked fair inside of the dimensions figured on plans with solid spiral steps of tooled Yorkshire or rubbed hard Portland, solid winders 6in. thick, with the outer ends pinned into the walls 6in. as the work proceeds in cement, with solid stone newel at the centre (give outside dimensions of each step). At each course of the turret (or every third course) the stones to be cramped together by copper (or galvanised iron) cramps run in with lead, each cramp to be 12in. or 15in. in length and 2in. by  $\frac{1}{2}$ in., and each bed to be dowelled with square slate dowels. Or—

48. *Circular Stair*.—The circular winding staircase to be of rubbed hard York stone, winders 6in. thick, with arris taken off, and to be 21in. in the clear. The newel to be worked out of each step solid (6in.) diameter, the other end pinned into

turret walls 6in. in cement as the work proceeds. The landings to be 6in. thick with solid newel worked on. Put a handrail of barrel iron 2in. in diameter, with flush screwed joints upon bracket supports fixed to walls at regular intervals screwed to handrail.

49. *Copings*.—The copings to gables to be of rectangular section, chamfered and throated on lower edge (see sketch 7), and to be 13in. by 4in. (or 6in.) thick, with apex stones, kneelers, and corbels as shown, bonded into the wall. The lengths of stones to be not less than 3ft. or 5ft., except the kneelers, and the coping to be bedded and jointed in cement, and cramped (if necessary) with copper cramps 9in. long, run with lead or with Spence's metal, sulphur, or cement. Or—

The copings to the gables to be saddle-backed, and to be cut out of stone 13in. (or 16in.) by 13in. (or more) in scantling, and of lengths not less than 3ft., bedded and jointed in cement, plugged (or dowelled) with lead (or slate in cement), and bedded and jointed in cement. Or—

50. *Balustrade Coping*.—The coping of balustrading to terrace to be of the section shown, a moulded saddle-back 12in. by 12in. (or 14in. square), the stones to be not less than 4ft. or 5ft. long, dowelled (or plugged) with lead, the joints being arranged to fall at the mitres of pedestals and over balusters. Mortises for slate (or copper) dowels to be made over each baluster.

#### ROYAL INSTITUTE OF BRITISH ARCHITECTS.

PRESENTATION OF THE ROYAL GOLD MEDAL.

THE meeting-room of the Institute of Architects at 9, Conduit-street, was thronged by ladies in evening attire and by members on Monday evening, the occasion being the formal presentation of the Royal Gold Medal for the year to Professor George Aitchison, R.A., who has just been elected President for a third year of office. On the walls of the room were hung many architectural drawings and schemes of decoration, illustrating works carried out by Mr. Aitchison, and a series of photographic portraits of the Gold Medallists of past years in frames of varying

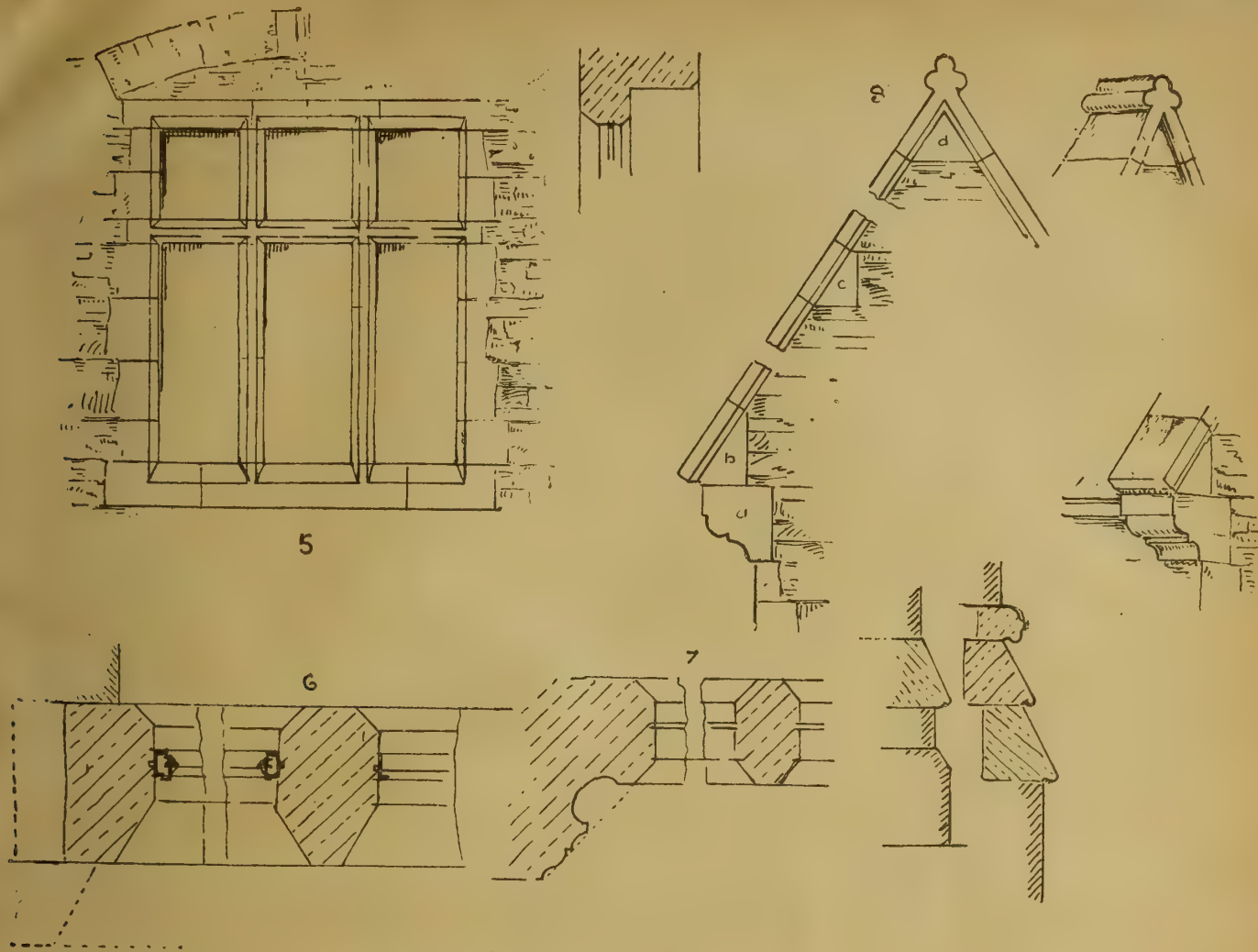

character had also been brought together, and added to the interest of the display. As is customary on these occasions, Messrs. Penrose and Brooks and the other Gold Medallists present wore their medals suspended round the neck by a broad dark blue ribbon, and the President, who occupied the chair, assumed, in addition to the massive gold chain and badge of office given to the Institute by the late Professor Donaldson, the Diamond Jubilee medal conferred upon him last year.

MR. WILLIAM EMERSON, hon. secretary, briefly opened the proceedings, stating the object of the meeting, and called upon MR. F. C. PENROSE, F.R.S., LL.D., ex-President, to make the formal presentation. Mr. Penrose, in the course of a graceful speech, remarked that it was perhaps well that the person who undertook the duty of investing the recipient of this honour should be independent of the body who made the selection of the name to be presented to her Majesty. He wished to show, he said, how fully the Council had been justified, both on architectural and literary grounds, in the choice they had made. Their President's father was an architect, and appeared to have destined him for the profession from the very first. Mr. G. Aitchison, senior, up to the time of his death, was architect to the St. Katharine's Dock Company. His practice was mainly in wharves, warehouses, and offices, and structural alterations on a large scale, and he built the road stations on the London and Birmingham Railway. Their President was educated at the Merchant Taylors' School until his sixteenth year, when he was articled to his father, and during his pupilage attended the science and art classes at Somerset House, where the late Mr. J. R. Herbert, R.A., was then master. In 1847 he became a student of the Royal Academy, and, after the completion of his articles, took the degree of B.A. at the University of London, in 1851, whilst continuing his architectural training in his father's office. In January, 1853, he travelled through France, and thence through Italy. Returning to Rome, he made valuable friendships with the artists assembled there in that year, 1853—viz., G. II.

Mason, the idyllic painter, by whom he was introduced to two future Presidents of the Royal Academy, Leighton and Sir Edward Poynter; and he also met Alfred Waterhouse and William Burges. Leaving Rome after the Holy Week of 1854, he travelled in company with Burges to Arezzo, Perugia, and Assisi, where they stayed some weeks, making notes and sketches of the important fresco decorations of Cimabue and Giotto in the church of San Francisco. Thence they went to Florence, where they stayed several months, making notes and taking sketches and measurements of some of the palaces and other monuments; then continuing their studies at Siena, Pisa, Lucca, and Pistoja. They proceeded via Leghorn to Marseilles, and visited Lyons, Beaune, Dijon, and Troyes together, where they sketched and measured ruins. The two friends then separated, and Aitchison met his parents at Paris, and with them returned to Italy, coming home to London in the summer of 1855. He then became his father's head clerk, and was taken into partnership with him in 1859. During this partnership he saw a great deal of work of an engineering character on the Chester and Holyhead Railway. In June, 1861, his father died, and he began practice on his own account, becoming architect to the St. Katharine's Dock Company. He was engaged chiefly on large massive works—wharves, warehouses, and suites of offices—but was enabled occasionally to introduce architecturally-designed fronts and staircases. The tobacco warehouse and offices and other warehouses for the Victoria Docks had a frontage of 500ft., by 170ft. in depth, costing £65,000. Messrs. Hubbuck's warehouse on the Thames has some architectural character. In 1865 he built Lord Leighton's house, to which the glass house, the Arab hall, and picture gallery were subsequently added; and he also designed the ornamental furniture of the house. Other works by the President include Berkeley Square, No. 1, South Audley-street, 9, Chesterfield-gardens, 52, Prince's-gate, and 1, Grosvenor-avenue. In 1869 he altered and decorated the hall and staircase at 44, Belgrave-

square, for the Hon. Percy Wyndham, for which paintings in combination were made by Leighton; and this led to his being employed in decorative work for the Princess Louise at Kensington Palace, for the Duke of Montrose, Lord Leonfield, Sir W. Lawson, Sir S. Waterlow, Mr. Eustace Smith, M.P., Mr. John Aird, M.P., Mr. J. H. Renton, and many others. In 1868 he built the new board-room for the Thames Conservancy, designing also the furniture, whilst Leighton modelled the frieze of the board-room. In 1871 he altered and enlarged the house of Mr. F. Lehman, M.P., 15, Berkeley-square, and designed the furniture. In 1884 a house for Mr. J. Stewart Hodgson, which had been left unfinished by the death of his friend F. P. Cockerell, was put into his hands to complete. For the same owner he also made large additions to his house at Lythe Hill, designed the fittings, and decorated the rooms. In 1877-78 he rebuilt Founders' Hall, and in 1886 the Royal Exchange Assurance Offices in Pall Mall, and in 1892 decorated in colour the Livery Hall of the Goldsmiths' Company. He designed the decorations for the British Art Section at the Paris Exhibition of 1878. He had been, Mr. Penrose added, elected a member of the *Société Centrale* of French architects, and also of that of Belgium, was a foreign Associate of the Royal Academy of Belgium, and had received numerous medals from our own colonial associations in recognition of his claims as an architect. In 1881 he was elected Associate of the Royal Academy, and in that position gave occasional lectures, but, since being chosen Professor of Architecture in 1887, he had given his lectures annually. To his architectural he had added much good literary work. He wrote the Science and Art Syllabus on the "Principles of Ornament." He edited, and partially rewrote, Ward's "Principles of Ornament" in 1892, and four years later added an Appendix on the Orders. He was a contributor to the "National Biographical Dictionary," and one of the examiners in the Science and Art Department at South Kensington. In conclusion, Mr. Penrose referred in high terms to the character of the Academy Lectures given by Professor Aitchison, observing

that they were calculated to encourage architectural students to keep before their eyes a high ideal of architecture as an art, based on sound construction, technical knowledge, and true principles of design as its essential aim. Mr. Penrose proceeded, amid loud and continued applause, to invest the President with the riband and medal.

Professor AITCHISON, who commenced his remarks hesitatingly and in very low tones, being obviously embarrassed, returned thanks for the honour conferred upon him—the greatest, he observed, that England could bestow upon an architect. The most cherished desire he had was, he said, to see English architecture come to the front, and erect masterpieces which should epitomise the grand thoughts of the day and give them a character which should attract mankind. When he looked at Westminster, Salisbury, York, Peterborough, and Lincoln, he could not think that our ancestors, the architects of those minsters, fell greatly below the designers of the most renowned cathedrals of Europe. He could not believe our nature could have sunk so much below the standard of our semi-barbarous forefathers of the 13th century as to be incapable of developing the architecture we had into a true presentment of the highest aspiration and the ideal beauty of our time. It must be because we had got into a wrong groove, and we must get out of it before architecture ever again became a progressive art and could equal or surpass the glorious masterpieces of the past. The Renaissance men got architecture out of the way of progress by casting themselves at the feet of the Romans, and proclaiming that Roman architecture was perfection and could not be surpassed, although they did some noble and some beautiful work; ever since all the architects of Christendom have only attempted to paraphrase some deceased architecture. No one could deny that architecture was the poetry of arrangement and construction, and we needed to have these at our finger ends before we could hope to progress, so that when the heaven-born genius came he would have his tools ready. Arrangement and construction alone would not give us all we want, or else the marvellous works in iron of the engineers would have given it to us. We had to study the methods of expression that the masters of our art had employed, to learn how we might express our thoughts in our own climate; and we must, too, of necessity have change and novelty; different times, different surroundings, and different circumstances begot a different frame of mind. He would suggest three fields in which our architecture might well be vastly improved: in the care taken with its mouldings, the study given to proportion, and a striving after freer use of colour.

Mr. ALEXANDER MURRAY, in expressing the thanks of the meeting to Mr. Penrose for his appreciative remarks, and to the President for his charming response, referred to the valuable help Mr. Aitchison had frequently and freely given the authorities of the Classical Department at the British Museum in the classification and arrangement of fragments of Greek sculpture and architecture.

The PRESIDENT announced that on Monday next a special business meeting would be held to further consider the revised schedule of professional charges, and evoked laughter and applause by inviting in the same tones visitors and members to partake of refreshments in the adjoining room.

#### THE PROPOSED CENTRAL STREET FROM HOLBORN TO THE STRAND.

THE Improvements Committee of the London County Council have submitted to that body a fresh scheme for the construction of a main thoroughfare from Holborn to the Strand. Various projects for piercing a street from north to south through central London have been formulated during the past nine years, and in 1892 one was presented to Parliament; but hitherto no proposition has met with approval or has ever passed the initial stage, although the need for such a means of communication becomes year by year increasingly urgent. The present scheme, as will be seen by the accompanying map, is to carry a new road, 100ft. wide, from a point in Holborn immediately opposite Southampton-row directly towards the Strand. The new thoroughfare will absorb the eastern side of Little Queen-street and proceed a little to the west of Lincoln's Inn-fields in a southerly direction, intersecting Great Queen-street, Sardinia-street, Vere-street, and

Stanhope street. Thus far, the scheme is practically the same as that proposed in 1892, 1895, and 1896; but at Stanhope-street, instead of continuing in a direct line to the Strand, the street bifurcates. The western branch, as wide as the main street (100ft.), passes in a south-westerly direction, crossing Drury-lane, and entering Catherine-street and the Strand close to Wellington-street, cutting through the *Echo* office and the Gaiety Theatre opposite, so as to form an approach to Waterloo Bridge. The eastern branch, also of the same width as the main street, passes from Stanhope-street through New Inn to the Strand at St. Clement Danes Church. The scheme also provides for the widening of the Strand for a considerable distance on the north side of St. Mary's Church, and for the acquisition of the whole of the site within the area bounded by the Strand and the two branch streets, taking for this purpose the publishing offices of the Strand Newspaper Company, Limited. The main street, and also its two branches, which will be almost semi-circular and symmetrical, will be 100ft. wide.

The scheme provides for the retention of the church of St. Mary-le-Strand, as the committee consider that the church to a large extent acquires its peculiar dignity and beauty from its present position in the Strand. On a former occasion, when it was suggested that the Council should cause the church to be removed, the proposal was received by the public with indignation. Moreover, the several powerful architectural societies in London strongly urge the Council to insure the retention of the building. The Council's superintending architect, Mr. Blashill, has called attention to the unfortunate result, from an architectural point of view, that would be produced by the removal of the church, and he has expressed the opinion that it is a fine and very meritorious building belonging to a good period of English architecture, and a highly picturesque object in all views of the Strand, and he considers that by its removal that thoroughfare would lose the chief feature of interest which it at present contains. The committee share this view, and have therefore arranged for the setting back of the frontage on the north side of the church, by which a good road will be provided to accommodate the traffic passing eastwards.

The scheme now proposed, however, will, the committee believe, provide a handsome architectural termination to the new avenue, for the whole of the triangular space (nearly four acres) between the Strand and the two branch streets will form one of the most central positions in London, and the architectural effect of the buildings which will be erected upon the site, will, when regarded in concert with the Law Courts, the flanking garden, and the two churches, constitute one of the finest street views in London.

London has suffered materially in the past from the fact that when main thoroughfares have been constructed too little consideration has been placed upon the value of architectural effect. A grand feature at the southern end of the new avenue, such as that which will be obtained by the buildings to which reference has been made, will not only confer dignity and beauty upon the thoroughfare, but will undoubtedly tend to enhance its importance, with the result that the sites fronting the new street will be increased in value, to the great profit of the Council, and therefore of the ratepayers. Moreover, from the enhanced value of those sites, it will necessarily follow that the buildings to be erected will be proportionately more handsome than would otherwise be the case, and the proximity of the edifices at the southern end of the main street will lead to the erection of structures at all parts of the avenue of perhaps equal architectural beauty. The committee therefore consider that, in the present instance, a bold scheme will prove to be the truest economy.

The committee's estimate of the net cost of the new street is astonishingly low, due to the fact that the properties to be acquired are chiefly of a very poor character, while sites in such a main thoroughfare will possess very great value. Powers will be sought to apply "betterment" to the properties which will be enhanced in value by, but will not be acquired for, the improvement.

The estimate of the chief engineer for the streets, subway, sewers, paving, &c., is £120,000. The estimate of the valuer for the acquisition of the property required for the whole improvement amounts, after deducting recoupment, to £354,200. The estimated net cost of land needed for providing accommodation for the persons of the labouring class to be displaced is £150,000. The

total estimated net cost for the whole scheme is, therefore, £624,200, which represents about three-sixteenths of a penny in the pound on the rates for the first year after the commencement of the improvement. This estimate will be somewhat reduced by the receipts from levying an "improvement charge" on properties benefited by the new route. The estimated net cost of the necessary property is put at £354,200. The gross cost is estimated at £4,442,500, and the recoupment at no less a sum than £4,088,300. The first charge on the rates will not accrue until three or four years hence. Powers for the improvement cannot be obtained until July, 1899, after which about two years will doubtless be occupied in the making of the initial valuation for the improvement charge, the formulation of a scheme for rehousing the displaced persons of the labouring classes, and the receipt of claims consequent upon the service of notice to treat.

A part of the district, in the line of the new street, consists of insanitary courts and alleys; in fact, some of the worst in London, with houses only fit to be pulled down. The clearance of these must, the committee holds, result in an incalculable amount of good. Perhaps the worst of them are those in the vicinity of Clare-street, Stanhope-street, and White Hart-street, and these are now being dealt with by the Council, under the powers conferred by the Housing Acts, the area having been formally represented as unhealthy areas by the medical officer of health for the district. The formation of the new thoroughfare and the subsidiary streets now proposed will displace about 3,030 persons of the labouring class, in addition to those displaced from the Clare Market area. In connection with the Clare Market rehousing scheme accommodation is to be provided in the immediate locality for 750 persons, but no account can be taken of that accommodation in considering the question of rehousing the 3,030 persons to be displaced by the new street. Of these 3,030 persons about 500 (including in each case the families of the workmen) are dependent upon occupations in the immediate locality, involving exceptional hours—i.e., early attendance in the morning and late attendance at night. These persons must be accommodated on the cleared land adjacent to the improvement; but this can be done without erecting any artisans' dwellings immediately on the frontage of the new street—a contingency which it is very desirable to avoid. About 410 persons are dependent upon employment in the locality not involving exceptional hours, and suitable accommodation for these persons and also for 840 more—i.e., about 1,250 in all—may perhaps be provided on the Millbank prison site, now in the possession of the Council. With regard to the remaining 1,280 persons, equivalent accommodation may be provided in a convenient locality in the suburbs. The net cost of providing land for the erection of dwellings to accommodate the 3,030 persons to be displaced is estimated at £150,000. We may mention that the Millbank site will accommodate about 4,400 persons of the labouring class. A portion of the site has been appropriated for the housing of 1,500 persons to be displaced by the Clare-market scheme. There remains, therefore, sufficient land to accommodate about 2,900 persons. The cost of appropriating land adjacent to the new street for the purpose of providing accommodation would be more than thirty times greater than if land at Millbank were utilised for the purpose.

The present scheme has the advantage of providing for easy gradients. The gradient of the proposed thoroughfare will at no part exceed 1 in 50, and will be that in the branch streets only. The gradient of several streets descending into the Strand is at present steeper than 1 in 30. The gradient of the main street will be about 1 in 100. In the scheme submitted to the council in July, 1892, it was proposed to form about midway between Holborn and Strand, and on the site of Sardinia-street and Vere-street, a circus at least 200ft. in diameter; but this circus has been omitted from the present scheme. The new street, being 100ft. wide, will afford ample space for a double line of tramways along its centre, besides fully providing for other traffic on either side; and the committee recommend that powers should be sought in the Bill for laying tramways along the new street. It may be possible later to extend the tramways along Southampton-row to the north, and also to the existing tramway in Theobald's-road and Clerkenwell-road to the east.

One of the most important features of the



PROPOSED THOROUGHFARE FROM THE STRAND TO HOLBORN.

scheme is that it will form a direct line of communication from the districts north of Holborn to the Embankment. The new street will deliver the traffic almost opposite to Norfolk-street and Arundel-street, and will thus afford easy access to the Temple Station, the School Board Offices, and the Embankment towards Blackfriars Bridge. It has been suggested to the committee that their scheme to be complete should provide for an extension of the proposed new street by means of a bridge across the Thames between Waterloo Bridge and Blackfriars Bridge. But this question does not fall within the reference, the provision of such a bridge being a matter for the consideration of the Bridges Committee, and the Improvements Committee have therefore thought it right to do no more than arrange that the line of the new street shall be such as will easily lend itself to any possible future extension of the street by means of a bridge across the river.

The committee point out that the widening of Southampton-row, in a direct line northwards from the new street, to 60ft. is in progress under arrangements by voluntary agreement made with the Duke of Bedford; while another feature of previous schemes, the removal of the "island" block of buildings between Holywell-street and the Strand, is about to be carried out under Parliamentary powers obtained by the County Council last session, a valuer having been nominated within the past fortnight; further, the insanitary areas between Clare Market and Drury-lane are about to be cleared and rebuilt under the authority of the Home Office and Parliament. The latter improvement suggests that if the street is to be formed at all, the necessary Parliamentary powers should be obtained without delay.

The aggregate cost of the improvements contemplated in this district will be as follows:—(1) Strand widening at Holywell-street, £569,000; (2) clearance of insanitary district at Clare Market and Drury-lane, £216,000; (3) Southampton-row widening, £162,000; (4) proposed new street from Holborn to Strand, £624,000; making a total of £1,571,000. This, compared with the estimate of 1892 for the same general scheme (£2,246,000) shows a difference of £675,000. It should be explained that this large reduction is due in part to the much better development of the surplus land resulting from the modification of the scheme of 1892 by the two branches to Wellington-street and the Law Courts, and in part to the economical arrangement made in the purchase of the Southampton-row property.

The committee say, in conclusion: "It seems to us that the arguments in favour of carrying out this great improvement at once are overwhelmingly strong. It is quite certain that delay even for one year will add enormously to the cost of the new road. It will also entail other inconveniences in respect of the laying out of the area to be cleared by the Housing Committee. The three improvements already in hand in this district will be immensely enhanced in value by the completion of the whole scheme in the making of the new road. It is certain that in no other part of central London could so great an improvement be effected so advantageously and at so small a cost. Streets 100ft. wide will be made for a length of more than 3,000ft., through one of the worst districts of London, opening up a much-needed communication between north and south, and between Holborn and the Strand, and offering great opportunities for architectural features. It will be an improvement of which the Council and London will have every reason to be proud."

The recommendations submitted are as follows: (a) That the Council do apply to Parliament in the session of 1899 for powers to construct a new street, and branch streets, 100ft. wide, from Holborn to the Strand, and to carry out the subsidiary street improvements in general accordance with the scheme shown on the plan approved by the Improvements Committee on May 25, 1898. (b) That the question of powers being sought to enable the Council to lay tramways along the new street be referred to the Highways Committee for consideration and report. (c) That provision be made for the construction of a subway under the new streets (for mains, wires, &c.), and also for the planting of trees in the new thoroughfares. (d) That provision be made in the Bill for part of the cost of the improvement to be dealt with on the same general principle as that embodied in the improvement charge sections of the London County Council (Tower Bridge Southern Approach) Act, 1895, but that a longer period than three years be allowed within which to judge of the

effect of the improvement upon the surrounding property. (e) That it be referred to the Housing of the Working Classes Committee to consider and report the best mode of rehousing the persons of the labouring class who will be displaced by the construction of the new street and its approaches.

The Improvements Committee of the London County Council have also resolved to recommend the Council to include the following schemes of public improvement in the Improvements Bill to be introduced by the Council next session:—High-street, Kensington, widening, estimated cost £81,000; Wandsworth-road, Lambeth, widening between Vauxhall Cross and Nine Elms-lane, £55,000; rebuilding of Cat-and-Mutton Bridge, Shoreditch, £68,500; rebuilding of the Old Gravel-lane Bridge, St. George's-in-the-East, £14,000. The total estimated cost of six contemplated improvements, without deducting contributions, is £1,004,700; and after deducting contributions, but not betterment, £955,700.

## ELECTRIC LIGHTING NOTES FOR ARCHITECTS.—XXV.

By AN ASSOC. INST. ELECT. ENGS.

### ARC-LIGHTING.

**I**NTRODUCTION AND HISTORICAL NOTES.—Arc-lighting is a system of producing light artificially by reason of the manifestation of the heat evolved by the passage of electricity through conductors of high resistance (concentrated at those points where light is desired); it is, however, quite distinct from that of raising a conductor to incandescence, as in incandescent lighting. In the incandescent system a conductor is raised to incandescence without combustion or consumption of the conductor taking place, whilst in arc-lighting combustion, disintegration, and consumption of the conductor are the natural products of the system. In the former air is excluded from the lamp, whilst in the latter air is essential for the proper working of the lamp, especially at the beginning. The principle of the arc-lighting system may be briefly stated as follows: When a sufficiently high difference of potential is maintained at the ends of two carbon rods in contact with one another, a powerful current passes through them, and, inasmuch as the resistance at the junction of the loose carbon contacts is very high, a temperature sufficiently intense to vapourise the carbon is produced at this point, so that upon gradually separating the carbon-pencils to a distance of, say,  $\frac{3}{16}$  in., a bridge of carbonaceous vapour is produced, and a dazzling arc of white flame is formed between them. This phenomenon was discovered by Sir Humphry Davy, and was by him termed the *electric arc*. The date of this discovery is usually given as about 1809; but in September, 1800, Davy announced that "he was able to produce sparks that were visible in daylight from the discharge of a primitive voltaic pile; and he found, in trying sparks between terminals of different materials, that these sparks were of different degrees of brightness. Amongst other materials that he names, he mentions that the bright spark visible in daylight was obtained by using well-burnt charcoal." In 1810, Davy demonstrated at the Royal Institution that he was able to produce permanent arcs by means of a battery of 2,000 elements; this battery was obtained by private subscription. Respecting his early experiments, in which he used two pieces of light wood charcoal about an inch long and one-sixth of an inch in diameter, we are told that when these "were brought near each other a bright spark was produced, and more than half the volume of the charcoal became ignited to whiteness; and, by withdrawing the points from each other, a constant discharge took place through the heated air in a space equal, at least, to four inches, producing a most brilliant ascending arc of light, broad and conical in form in the middle."

The temperature was so intense that even refractory materials placed in the arc "became incandescent; platinum melted like wax in the flame of a candle; sapphire, magnesia, lime, and the most refractory substances were fused. Fragments of diamond and granite rapidly disappeared without undergoing any previous fusion." At this point we may refer to the origin of the term *arc*. In the early experiments of Davy the charcoal pencils were fixed horizontally, in which case the bridge of glowing

carbonaceous vapour formed an arch or bow as the result of the ascending heated air current; and the abbreviation of arch, or *arc*, then introduced has been retained. With the vertical position, as now usually given to the carbons, the bow or arch shape is not produced.

As would be expected, the discovery of the electric arc attracted the attention of numerous workers, and in course of time many improvements were suggested; but until the dynamo was perfected as a generator, little or no practical progress was made in electric lighting. The work done was experimental, and at that time the only source of electrical energy was the voltaic cell, which is not suitable or economical for commercial purposes. The following are additional interesting historical facts. About 1844 Foucault definitely proposed the use of pencils of retort carbon, and in 1846 Mr. William Edward Staite introduced the first mechanical arc lamp. Probably the first real practical arc lamp, in which the regulation was automatic and electrical, was that designed by Serrin in 1857; but it was not until 1878 that Brush and Jablockhoff introduced the arc lamp for street-lighting. Since then its growth, especially in America, has been rapid.

*Arc Lamps.*—We are now in a position to consider the arc lamp, and the phenomenon of the electric arc in detail. An arc lamp is a piece of apparatus devised to support two carbon rods or pencils, and to automatically regulate the position of these carbons, so that a permanent and steady arc is formed when the lamp is supplied with electrical energy. The operations which such a device has to perform are as follows:—(1) To bring the carbon pencils into contact when no current is passing; (2) to separate the carbons a definite amount, or *strike the arc*, as it is technically termed, as soon as the current passes; and (3) to regulate automatically the length of the gap between the carbon points by causing the pencils to approach when too far apart, and to separate them when too close; this is technically known as *feeding the arc*. Innumerable methods have been devised to perform these operations, and presently we shall refer to the fundamental principles of arc-lamp mechanism; but before doing so we must consider the carbons and the physics of the arc. For the present our remarks will only refer to continuous-current arc lamps.

When we remember that the difference of potential usually applied to the terminals of an arc lamp is not sufficiently high to cause sparks to pass from one pencil to the other, it is obvious that the light emitted from an arc lamp must be produced by the passage of electricity across the gap which is filled with a gaseous conducting medium, due to the volatilisation of the positive carbon. And it is now generally admitted and well understood that this volatilisation enables us to explain the phenomenon of the arc. There is, for instance, the transportation of the intensely heated carbonaceous vapour across the gap, resulting in the formation of a crater at the tip of the positive carbon. Moreover, it is at the surface of the crater that the electrical energy is converted into thermal and light energy, and the work done in this locality by the dissipation of a definite amount of electrical activity results in the production of a corresponding definite high temperature. As is well known, carbon is the most refractory of known substances, and it has, therefore, the highest temperature of volatilisation. Furthermore, this temperature is fixed and definite, depending only upon the material used, and the result is an incandescent luminous crater forming a glowing white surface, in which carbon is being boiled into vapour at the temperature of volatilisation. Captain Abney has shown by his researches that the white light of the incandescent surface of the crater is of constant quality and luminosity, irrespective of the magnitude of the current, size of the carbons, and length of the arc. This constancy in the intrinsic luminosity of the crater surface implies that its temperature is fixed by physical conditions, and that the temperature of the light-emitting surface is always the same. It is for these reasons that the view—that the temperature of the carbon at the surface of the crater is that at which it evaporates—receives so much support. Increase of electrical activity, therefore, cannot increase the temperature of the crater surface beyond the limiting temperature of volatilisation of the material used. There is also evidence that the carbon undergoes incipient liquefaction just before volatilisation takes place, as was first suggested by Despréts about 1850, and Professor S. P. Thompson's view of the



physical state of the arc crater is "that the solid carbon below is covered with a layer or film of liquid carbon just boiling or evaporating off." Much speculation has existed as to the actual temperature of the arc, extravagant temperatures, varying from 2,000° to 10,000° C. having been quoted. The best experimental result is probably that obtained by Violle, whose measurements indicate a temperature of 3,500° C. as that of the crater.

Since the crater of the positive carbon is the main source of light, the positive carbon, with its luminous crater, is always placed above the negative carbon, so that the light is thrown downwards. "About 90 per cent. of the light comes from the crater, and about 4 or 5 per cent. from the negative peak, while comparatively little comes from any other part. Around the rim of the crater there is, however, a region that is less luminous, not so hot, and of a redder colour; and there is a certain small percentage of light—not more than 3 or 4 per cent. of the total light at most—emitted from the intermediate flame. Now, of course, there results from this a peculiar distribution of light in the space all round; the light is, in fact, thrown mainly downwards." The negative carbon must of necessity be at a high temperature, but much below that of the positive, consequently it adds little to the general illumination—in fact, its temperature is such that it permits the condensation of the carbonaceous vapour upon its



FIG. 86.

surface. So long as the arc is maintained oxidation takes place, and the ends of both carbons become somewhat conical in shape. The appearance of the carbons is shown in Fig. 86.

What the carbon filament is to the glow-lamp so the crater and carbonaceous vapour are to the arc lamp—i.e., the essential elements. For these we have to depend upon the carbon pencils; and to insure the production of that high-quality illumination which is so desirable, the carbon pencils should possess certain essential qualities. As we have already pointed out, everything depends upon the temperature of volatilisation of the carbon, and to secure the requisite constancy of this temperature the pencils should possess a uniform and dense texture, fine grain, freedom from impurities, and be well baked. They should also be of uniform cross-section. The want of uniformity or the presence of impurities produces variation in the volatilisation, and consequently variation of temperature at the crater surface. And all this simply means variation in the intensity of the light emitted. Even in his early experiments Davy found "that to render charcoal well-conducting and satisfactory, it must be hard, dense, well burnt so as to be metallic in lustre, and that it answered best of all if it were suddenly quenched in quicksilver." Fleming gives the following reasons why carbon (graphite) is suitable for the pencils of an arc lamp.

(1) It is a rather poor conductor of electricity, and the lower the electrical conductivity the greater is the difference of temperature between

the positive and negative poles when an arc is produced between them. It has also the advantage of having a highly heated crater on the positive pole.

(2) It is easily disintegrated; therefore there will be a longer arc for a given electrical pressure.

(3) It is very infusible, and its oxide is a gas; therefore a deposit of oxide is not formed in or around the crater.

(4) It is an inferior conductor for heat; therefore the high temperature is localised at the crater.

It is also noteworthy that the degree of



FIG. 87.

infusibility decides the intensity of the electrical pressure required to produce a true electrical arc.

*Manufacture of Arc Light Carbons.*—Charcoal, even if well burnt, is speedily consumed, as Davy found to be the case during the early experimental stage, and although the blocks sawn from the hard deposits of gas retort carbon (graphite), as introduced by Foucault, answered well during the later experimental stages, it was found necessary to introduce a definite process of manufacture when the arc lamp was introduced for commercial purposes. Considerable difference exists in the different processes of manufacture; but these are in matters of detail, and the following may be taken as a general outline of the manufacture of arc-lamp carbons.

The base in nearly all cases is graphite or retort carbon, which is thoroughly pulverised (although in some cases powdered coke is used), and the powdered carbonaceous substance is mixed with gas-tar, syrup of sugar-cane, or some other carbonaceous liquid, so as to form a stiff paste. The paste is then moulded or forced by hydraulic pressure through a die-plate, and after being dried it undergoes the carbonising process by being baked in a closed vessel in a furnace. During this process the carbonaceous compounds are decomposed, and a fairly pure form of carbon is produced. To insure purity, homogeneity, electrical conductivity, a dense and uniform molecular texture, the rods are often repeatedly soaked in some carbonaceous syrup, and rebaked each time. To give some idea of the actual composition of the paste we may state that Carre's carbons are made of pure coke fine powdered, 15 parts; calcined lampblack, 5 parts; special syrup, 7 to 8 parts; and after the mixture has received from 1 to 3 parts of water, and a perfect paste is formed, it is ready to be moulded.

In many cases the carbons are electrolytically

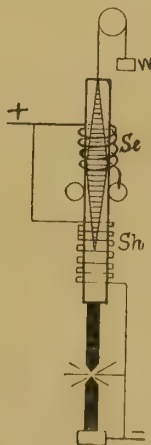

FIG. 88.

coated with a deposit of metallic copper to insure more perfect conductivity, better contact at the holder, and more uniform consumption. In the earlier days of manufacture it was more necessary to plate the carbon with copper than it is now, when the quality of the carbons is so much better,

Even when coated with copper it is often found that the position of the arc is not constant, and inasmuch as the steadiness of the arc depends largely upon this, the positive carbon is made larger and cored. That is, the central portion is made of softer material, which, being more readily volatilised, tends to keep the crater central. Cored carbons to a large extent prevent the lateral shifting of the arc, and steadiness in burning is secured. The negative carbon of continuous-current arc lamps are, however, not cored, whilst in alternate-current arc lamps both carbons are cored.

In some respects English practice differs from that of America. In America arc lamps are usually connected in series, the carbons being equal in cross-section, and solid throughout. With a current of 10 amperes the length of the arc is about one-tenth of an inch. In England, parallel running is more common, and the positive carbon is usually cored, and larger than the negative. The usual length of the arc is from one sixteenth to one-twelfth of an inch. The usual sizes of carbons—positive cored and negative soled—for different currents, are as follows:—

Current in Amperes.	Diameters in Millimètres.	
	Cored Positive.	Soled Negative.
5 and 6	9	9
8	11	9
10	13	11
15	15	13
20	18	15
30	20	19

At this point it will be interesting to note that when the quantity of illumination required is large and somewhat variable, as in lighthouse work, round carbons are not so suitable as fluted ones. They burn irregularly, and the position of the crater is unsteady when the currents are large, and they are liable to become red-hot throughout their length when traversed by the heavy currents required. Fluted carbons, however, offer larger cooling surface than cylindrical ones, and, if cored, tend to keep the arc central. At the South Foreland Lighthouse the fluted carbons are about 60 millimètres in outside diameter, and the current, which is alternating, varies from 130 to 300 amperes, according to atmospheric conditions. The section of a fluted carbon is shown in Fig. 87.

Since the carbon pencils disintegrate and burn away, the lasting power of the carbons is an important factor. Generally speaking, the time of burning varies directly as the diameter, and, with continuous currents and both carbons of the same diameter, the positive wastes away twice as fast as the negative. In ordinary 10-ampère lamps the positive carbons burn at the rate of 1½ in. per hour—that is, 1ft. of positive and 6in. of negative last about eight hours. Of course, much depends upon the quality and character of the carbon, the strength of current, and the size of pencils. If the carbons are too thick they give less light per watt, but give a steadier light and possess more lasting power. If too thin they give brighter light and more light per watt, but the craters are not so good, and the pencils tend to get hot, and so burn away more quickly. In practice it is found that the crater reflects most light when the axis of the negative carbon is in line with the edge of the positive carbon.

*Arc Lamp Mechanism.*—The gradual disintegration and consumption of the carbons, which take place whilst the lamp is burning, would result in the gradual elongation and ultimate extinction of the arc, if the carbons were fixed relatively to one another. It is, therefore, obvious that, inasmuch as variation in the length of the arc means unsteadiness of illumination, some automatic regulation is required to keep the pencils the proper distance apart, and as we have already pointed out, arc lamps are now constructed to bring the carbons into contact at the beginning, to strike the arc, and also to feed the arc. Generally the regulation is controlled by a portion of the electrical energy supplied.

The construction of a perfect arc lamp offers much scope for ingenuity, advantage of which has been freely taken by many inventors, and numerous examples of both mechanical and electrical regulation have been devised. In many of the early lamps the regulation was purely mechanical, and comprised various kinds of clock-work, racks, brake-wheels, clutches, levers, &c. Taken as a whole, such mechanism is objectionable, and not nearly so reliable as that of

electrical control, and we find in consequence that modern arc-lamp mechanism is purely electrical. In nearly all cases advantage is taken of the electro-magnetic action of solenoids, electro-magnets, and motors as sources of power to give the required motions to the carbon pencils. For many reasons electrically governed arc lamps are preferable to those governed mechanically, and although many of the mechanical arrangements devised are very interesting, our purpose will best be served by considering only the principles applied in the modern and electrically governed

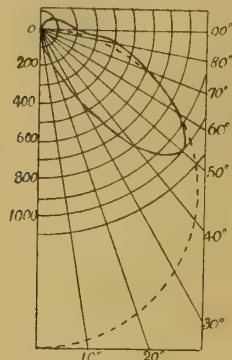

FIG. 89.

lamps. By reason of the antagonistic effects produced by two distinct and separate coils or electro-magnets, the majority of modern arc lamps may be termed *differential lamps*, the action of which will be readily understood by considering Figs. 88-91.

These more or less diagrammatic figures are given to show how two continuous opposing forces may be produced. Fig. 88 shows the concentric winding of the two coils, which are traversed by currents in opposite directions. Fig. 89 shows how to produce differential motion with one plunger, whilst Fig. 90 shows how differential motion is produced by means of two plungers attached to one lever or connected by means of an intermediate pulley. It will be noticed that in each case there are two coils, *Se* and *Sh*, the former of which, known as the *series coil*, consists of a few turns of thick wire having a resistance of about 0.05 ohm, and as it forms part of the main circuit by being connected in

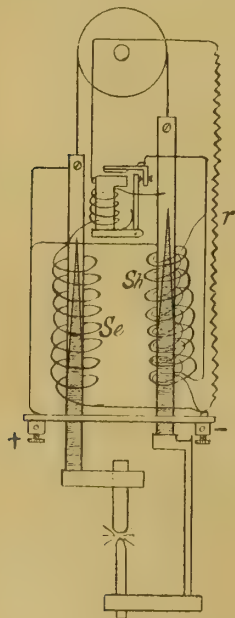

FIG. 90.

series with the arc, it is traversed by the main current. The other coil, marked *Sh*, is wound with many turns of fine wire, its resistance being great in comparison with that of the series coil. It is connected, as shown, in parallel with the main part of the lamp—i.e., series coil and arc—and is therefore known as the *shunt coil*.

To explain the action of these coils, we shall assume that the carbons are in contact at the

time the lamp is supplied with current at the proper voltage (from 40 to 50 volts), and since there are two paths open to the current, one of large resistance compared with that of the other, it is evident that nearly the whole of the current will traverse the series coil, in consequence of which the electromagnet action of that coil will be great. The holder of the positive carbon then moves upwards, and, the carbons being separated the proper amount, an arc is established between them; in other words, the arc is struck. As the carbons burn away, the resistance of the arc, and, therefore, that of the main circuit, increases, so that more current now passes through the shunt coil, its magnetic properties are strengthened, and, acting in opposition to the series coil, the carbons are made to approach each other. In this way the length of the arc is automatically maintained constant, the arrangement being designed so that a steady feed exactly equal to the rate of consumption of the carbons is obtained.

As we have already inferred, there are two general methods of connecting arc lamps in practice: (1) in series, and (2) in parallel between leads. Lamps for series-working are constant-current lamps, and those for parallel-running constant potential lamps. The latter differ from the former in that they require a steadying resistance coil, *R*, connected in series with the main circuit. This coil is shown in Fig. 91. Its function is two-fold: it regulates the difference of potential required for the lamp and at the same time steadies the current. Constant difference of potential lamps without this resistance coil work unsatisfactorily, as then the current fluctuates with every variation in the resistance of the arc. With the resistance coil, the voltage at the terminals of the shunt coil increases as the

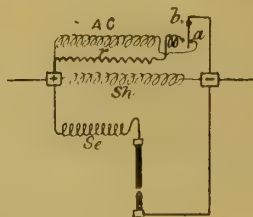

FIG. 91.

resistance of the arc increases, and its regulation is more effective. Constant-potential arc lamps are usually connected two in series across incandescent lamp mains at 110 volts. This series coil is not so necessary with constant current lamps, a large number of which are connected in series, since they tend to steady one another. When lamps are connected in series, it is usual to employ an additional piece of mechanism, termed an *automatic cut out*, so as to provide a by-pass, as it were, for the purpose of preventing the opening of the entire circuit, should the failure or total consumption of, or accident to, the carbons of any one lamp put that lamp out of circuit. Such a device is shown in Fig. 91, and is marked *A.C.* The automatic cut-out is practically a relay, and consists essentially of an electro-magnet and its armature, *a*, pivoted at *b*, as shown. The electro-magnet is wound with a fine wire and a coarse wire winding, the former of which is connected as a shunt to the lamp, and as it is connected to the armature, and thus to the negative terminal of the lamp, it is always in circuit; but as its resistance is high, very little current flows through it; normally it is not powerful enough, under ordinary circumstances, to attract the armature. When, however, the main current through the carbons is interrupted, the increase of current through this coil magnetises the core sufficiently to attract the armature *a* against the left-hand contact, the second, or thick wire coil of the cut-out is put into circuit, and as the armature still makes contact with the left-hand contact, the main current passes through, and thus shunts the lamp. In series with the low-resistance coil is the permanent resistance *r*, arranged so that the total resistance cut in is equal to that cut out.

**The Candle-power of Arc Lamps.**—The amount of light or candle-power emitted by an arc lamp is not given off uniformly in all directions, and the luminous rays form a cone with its apex at the crater. The amount of light therefore varies in different angular positions, the variations being due to the following circumstances:—

- (1) The positive crater, the main source of

light, is not a plane surface, but is concave; the principal distribution of its radiant flux is consequently downwards.

(2) The crater being surrounded by a wall of opaque carbon, the horizontal intensity of the emitted light is comparatively small, and, since the edges of the wall are irregular, the horizontal intensity varies in different azimuths.

(3) However closely the axis of the two carbon electrodes may be aligned, the arc will rarely remain long at the centre, but tends to travel around the edges of the positive carbons, thereby causing the crater to appear on the side of the arc, and tending to increase the illumination on that side.

(4) The arc is usually accompanied by some flame of a reddish colour surrounding the arc proper, like a luminous cloud, and the light from this source is of an unstable, flickering nature, shifting irregularly.

(5) Even the smallest mechanical irregularity or chemical impurities—liable to be present in the best carbons—develop fluctuations in the intensity of the light.

Photometrical measurements of the light of an arc lamp are not easy to make, and the results obtained are generally represented by a polar curve, constructed in polar co-ordinates representing the candle-power—that is, the intensities of illumination are represented by lengths plotted to some convenient scale along the angular directions at which the observations are made. The polar curve thus represents graphically the effective luminous intensities at different angular positions about the arc as an axis. Such a curve is given in Fig. 92.

All such curves exhibit the same characteristics, and there are two distinct types of variations:

- (1) there is the emission of a small quantity of light in a direction above the horizontal when the crater is deep, as with large current lamps; and (2) the curve narrows and indicates the concentration of a large proportion of the light between the angles of 30° and 60° with the vertical.

“Now, the quantity of light emitted by an incandescent disc in any direction is proportional to the amount of surface visible from that direction. That is to say, candle-power varies, then, as the cosine of the inclination. Cosines plotted as a polar curve give a circle passing through the pole. The candle-power of the crater of an arc lamp should, then, if plotted as a polar curve, coincide with part of a circle. Any deviation from the circle must have some cause.” The full curve given in Fig. 92 is given by Mr. A. P. Trotter, and “represents the mean of a large number of observations made, no less than 26 different arcs having been tested. The cosine of 60° being one half, the area of the crater seen from this direction is one half that of the full circle; the candle-power is one half of that emitted by the crater; and the length of the radius vector corresponding to 60° may be taken as the radius of the circle. The light due to the negative carbon is clearly shown as an excess above the circular curve. There is, indeed, nothing else to which it can be due, except the red-hot walls of the crater. At about 60° the curve of candle-power begins to fall off, and this is due to nothing else than the shadow of the lower carbon, which intercepts more and more of the light as we pass to smaller angles, until if the carbons be of the same diameter, no light is drawn in a vertical direction.”

The *mean spherical candle-power* is defined as the average candle-power taken all over the surface of a sphere having the arc as its centre, and as a rule it is between 30 and 40 per cent. of the maximum candle-power. The mean spherical candle-power is given approximately by the formula—

$$S = \frac{H}{2} + \frac{M}{4}$$

where—

- S = mean spherical intensity or candle-power,
- H = “ horizontal “ “ “
- M = maximum “ “ “

And it may be shown that the total quantity of light emitted will be  $4\pi S$ , in units of luminous flux.

It is interesting to note that the quality of the illumination of an arc lamp is the nearest approach to that of the ordinary sunlight of any of the illuminants, whilst its intensity is greater than that of any other artificial source of light. Of course, much depends upon the character of the carbon, and, although the carbons may be cheap and have a long life, they are neither efficient nor economical if the light be unsteady

or of low candle-power per unit of electrical energy expended.

The following notes on street and general lighting, taken from Geipel and Kilgour's "Electrical Engineering Formula," will be useful:—"The horizontal surface is, perhaps, most important, and the illumination thereof varies closely as cos.<sup>2</sup> θ, θ being the angle of incidence for angle greater than 45°. In order that the variation in illumination may not be too great, the distance of arc lamps apart should not exceed about six times the height, in which case, when

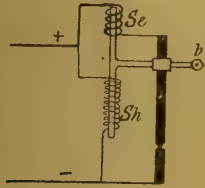

FIG. 92.

using 10-ampère lamps, the maximum illumination is about one candle-foot, and the minimum 0.06. If the distance is four times the height, then these figures are 1.1 and 0.22 respectively. Perhaps 0.03 candle-foot is the lowest permissible illumination for a well-lit street. The table gives a few instances of the placing of arc lamps. It will be observed that for street-lighting the distance apart varies from about 115ft. to 300ft., and the height from 17.6ft. to 26.7ft.

	Ampères per Arc.	Distance Apart in Feet.	Height of Arc in Feet.
City of London streets ..	10	115	17.6
Glasgow streets .....	10	160	18.0
Hastings streets .....	10	330	18.0
Berlin streets .....	15	137	26.7
Milan streets .....	80 to 100		25.0
Charing Cross-rd Station.	10	90	18.0
Cannon-street Station ...	15	180	35.0
St. Pancras Station .....	10	60 to 80	14.0
Central Station, Glasgow	10	75	19.5
St. Enoch's Stn., Glasgow	10	90	19.0
Edinburgh Exhbitn., 1886	10	33	12.0
Edinburgh Exhbitn., 1886	15	41	18.0

Railway Lighting.—"The Midland Railway Company adopt the following practice with 10 ampère lamps:—

	Distance Apart in Feet.	Height of Arc in Feet.
Platforms and booking-halls .....	60 to 90	14
Goods-sheds over decks .....	80	14
Goods-sheds over cartways & roads	80	18
Goods-yard, unloading roads .....	100 to 110	2)
Goods-yard, ordinary sidings .....	120	20
Approach roads .....	120 to 150	25

When 7-ampère lamps are used, the distances are reduced by 10ft. to 15ft. Opalescent globes are used in sheds and stations, clear globes outside. About ½-watt per square foot is a fair allowance for lighting large halls, exhibitions, &c.; 1 watt for large reading-rooms, libraries, &c.; 2 watts for intense illumination, such as is required at the South Kensington Museum."

"Globes of clear glass absorb 10 to 20 per cent. of light; mediæval rippled glass, about 22 per cent.; ground glass, 30 to 40 per cent.; heavily ground glass, 40 to 50 per cent.; and heavy opal glass 50 to 60 per cent. Large globes absorb more light than small ones."

In conclusion, we may note the following defects, and their causes:—

*Sputtering* is due to uncleanness and impurities in the carbons.

*Hissing* is due to too coarse a grain, or too short a gap, in consequence of defective feed—i.e. feed too rapid.

*Flaming, flickering, and irregular burning* are due to presence of impurities, insufficient baking, or too long a gap.

*Inconstancy in the candle-power* may be due to poor carbons, inconstancy in the rate of supply of energy, and variations in length of arc.

(Concluded.)

The Lord Lieutenant of Surrey, Viscount Midleton, has formally opened a cottage hospital and nurses' home for Haslemere, the gift of Mr. J. W. Penfold, F.R.I.B.A., and his sisters, as a permanent memorial of her Majesty's long reign.

ENGLISH ART IN THE EIGHTEENTH CENTURY.

AT the Passmore Edwards Settlement at Tavistock-place on Friday afternoon Mr. Humphrey Ward delivered the first of a series of four lectures on "English Art in the Eighteenth Century." He began by remarking upon the increased interest which had been directed during the last twenty years, both at home and abroad, to this art, the result in a great measure of the winter exhibitions at the Royal Academy and similar displays. The French were paying us the compliment of admiring our art, whether contemporary or distant, as something fine in itself and quite unlike their own. Meissonier was a passionate admirer of Millais, just as Delacroix had been of Constable and Bonington. It was natural that in this retrospective age we should look back upon the origins of our contemporary art, and, in point of fact, scholars had explored the 18th century with passionate curiosity, while rich amateurs had for many years past been eagerly competing with one another for the best English works of that time. It happened that there was in existence a little French book, Rouquet's "Etat des Arts en Angleterre," published in 1755, which showed that long before Delacroix there were foreigners who interested themselves in English art. Rouquet was an enameller who lived in London for about 30 years, and who was a friend and admirer of Hogarth. He remarks that English people had always cared more for science than for art; that there was no such thing as organisation among the artists of his day, and very little patronage; but that in two respects English art was showing signs of abundant life. The English loved portraiture, though only just beginning to produce portrait-painters of their own, and they loved the subjects with a moral which Hogarth had taught them to admire. The lecturer then proceeded to sketch the life of Hogarth, and to point out how in modern times the interest in Hogarth the moralist had declined, while that in Hogarth the artist had increased. He showed by various lantern slides some of the great qualities of that first of English painters, remarking that the sketch of "A Shrimp Girl" in the National Gallery placed him almost on a level with Frans Hals. From this point he proceeded to trace the various attempts that were made by the artists to organise themselves; their numerous failures, and their final success when Michael Moser, William Chambers, and Benjamin West persuaded the young King in 1768 to found the Royal Academy with Reynolds at its head. The second lecture, to be given this (Friday) afternoon, will be devoted to the life and works of Reynolds.

CHIPS.

Major-General H. D. Crozier, R.E., an inspector from the Local Government Board, held an inquiry yesterday (Thursday) into an application of the urban district council of Hunstanton for the borrowing of £3,000 for the purchase and improvement of the esplanade grounds for public walks and pleasure grounds.

The partnership hitherto subsisting between J. W. Falkner, W. J. Falkner, and A. B. Falkner, builder and contractors, Osory-road, Old Kent-road, S.E., under the style of J. W. Falkner and Sons, has been dissolved, so far as regards W. J. Falkner.

The sub-committee of the Lord Provost's Committee of Edinburgh Town Council, to which has been remitted the question of selecting a site for the Usher Hall, decided on Monday by a majority to recommend a site at the extreme western corner of the West Meadows, in the angle between Lonsdale-terrace and the Melville Drive.

The Canals Protection (London) Bill, which gives power to the local authority to require a canal company to provide for the protection of dangerous places on canals in the county of London, passed through committee in the House of Lords on Tuesday with verbal amendments.

The parish church of Burnham Overy, Norfolk, was reopened last week, after restoration from plans by Mr. Herbert J. Green, Norwich. Mr. F. Norman, of Burnham Westgate, was the contractor.

It was announced on Saturday that the fund opened at Bristol five days previously on the appeal of the bishop for extending Church agencies and providing additional church buildings has already reached £12,000. Besides this, £7,000 has been given by one subscriber. This is to go in the purchase of sites. Twenty new churches, 14 mission buildings, and 30 extra curates are required, the sum necessary to carry out the scheme being £100,000.

OBITUARY.

By the lamented death of Sir EDWARD BURNE-JONES English art loses one of its most brilliant colourists and one of its most imaginative poets in paint. With the possible exception of Mr. G. F. Watts, no artist held a higher place in the regard and affection of all lovers of English art than the distinguished painter who passed away on Sunday morning. His Classic subjects were treated with a Middle Italian feeling, and displayed withal much grace of line, a charm of composition, and a purity and wealth of colour all peculiarly his own, although it must be confessed his draughtsmanship of the human figure left much to be wished for. Edward Burne-Jones was born in Birmingham in 1833, and was thus 65 years of age. He was of Welsh descent. His parents intended that he should take orders in the Church of England, and his education at King Edward's school, Birmingham, was arranged to that end. He was an ardent classical student, and the old-world myths had ever for him an irresistible fascination. In 1852 he went to Oxford, and at Exeter College he met the late William Morris—who proved a kindred spirit; and the two having taken great interest in the "P.R.B." movement, determined to give up the Church and turn to art. With Rossetti for friend and teacher, Burne-Jones from 1865 devoted himself to the study of art. His first cartoons for stained glass were made for the chapel of Bradfield College in 1857. In 1859 Burne-Jones was in Italy visiting Florence, Pisa, Siena, and other cities; and was greatly influenced by the tender charm of Angelico, Botticelli, and the earlier Italian artists. On his return he designed many stained-glass windows, and painted altar pieces and pictures. These included a series from the *Morte d'Arthur*, from Mallory's *Romances*, and "The Legends of Goode Women." In 1864 Mr. Burne-Jones was elected an Associate of the Water-Colour Society, and began the illustration of his friend William Morris's poem "The Earthly Paradise," and prepared some 70 designs for the story of "Cupid and Psyche," which were subsequently bought by Mr. Ruskin, and presented to the Oxford Museum. In 1870 he exhibited a picture with a mythical Greek subject. About its meaning a dispute arose, which led Mr. Burne-Jones to resign his membership, and it was not until 1888 that he was again re-elected. For seven years he ceased exhibiting in London, save in 1873, when to the Dudley Gallery he sent his beautiful pictures "Love among the Ruins" and "The Garden of the Hesperides." But he was during this period executing a series of beautiful works, "The Briar Rose" series, "The Days of Creation," "The Mirror of Venus," "The Beguiling of Merlin," "The Feast of Peleus," "The Golden Stairs," and his series in which the Virtues and the Graces were personified by charming single figures. When the Grosvenor Gallery opened in 1877 the works of Mr. Burne-Jones constituted the great attraction of the show, and to that gallery and to the New Gallery which succeeded it the best of his work was contributed. One of Sir Edward Burne-Jones's windows is in St. Giles's Cathedral, Edinburgh, the subject being "The Holy Women at the Tomb." Her Majesty conferred a baronetcy upon him in 1894. In 1885 the Royal Academy made what many thought a tardy recognition of Sir Edward Burne-Jones's position in English art by electing him an Associate at Burlington House; but the artist only once (in 1886) exhibited a picture called "The Depths of the Sea." In 1893 he resigned his connection with the Academy. The deceased baronet is survived by Lady Burne-Jones, and by his son and heir, Philip Burne-Jones, an artist also of recognised merit, and by one daughter. His body was cremated on Monday, and the ashes were buried at Rottingdean Church on Tuesday.

SIR JAMES NICHOLAS DOUGLASS, F.R.S., M.Inst.C.E., M.Inst.M.E., M.Inst.E.E., late engineer-in-chief to the Corporation of Trinity House, died at his residence of Bonchurch, Isle of Wight, on Sunday, in his 72nd year. Born at Bow, Middlesex, on October 16, 1826, the son of Mr. Nicholas Douglass, of Stella House, Penzance, he received a regular training in civil and mechanical engineering. His first important employment was in 1847 as assistant engineer to his father, who was superintending engineer to the Trinity House, and was then engaged in erecting the lighthouse on the Bishop, the westernmost of the Scilly rocks. Mr. Douglass, jun., was next appointed resident engineer in

sole charge at the erection of the lighthouse on the chief rock of the dangerous group of the Smalls, off Milford Haven. This work he completed at a cost of a little over £50,000, or about £15,800 below the lowest contract price. In 1862, on the death of Mr. James Walker, F.R.S., engineer-in-chief to the Trinity House, Mr. Douglass was appointed to succeed him. During his tenure of the post he carried out many important engineering works both at home and abroad, including the Wolf, Longships, Great and Little Basses, Eddystone, and Muricoy lighthouses, and he effected numerous technical improvements connected with lighthouses and their illuminating apparatus, as well as in buoys and beacons. On the completion of the present Eddystone lighthouse in 1882, a work he executed at a cost of £24,000 below the lowest contract price, he was knighted. Sir James Douglass was in favour of oil illuminants in lighthouses, for the development of which he devised a special apparatus. On the other hand, the Commissioners of Irish Lights, advised by the late Professor Tyndall, warmly approved the invention of an Irish gentleman named Wigham for facilitating the use of gas. A warm controversy arose upon the matter, and ultimately, in 1883, Professor Tyndall resigned his post of scientific adviser to the Trinity House and to the Board of Trade. Early in 1892 Sir J. N. Douglass retired from his post at the Trinity House owing to ill-health.

#### CHIPS.

A new mortuary has been erected at Lewisham, and special consideration has been given to the ventilation, which will be carried out on the Boyle system.

Mr. G. W. Willcocks, an inspector of the Local Government Board, attended at the town hall, Leamington, on Friday, to hold an inquiry in reference to the application of the corporation for permission to borrow £5,500 for works of water supply, and £5,010 for purposes of public walks and pleasure-grounds.

The members of the Lincolnshire and Nottinghamshire Architectural and Archaeological Society visited the town of Lynn on Tuesday in last week. Next day they visited Hunstanton, Heacham, Snettisham, Dersingham, and Castle Rising. Returning to Lynn, they were served with dinner, after which the Mayor and Mayoress entertained them at a conversazione. Thursday was devoted to the churches in Lynn, and to a drive from Swaffham to Southacre and Castleacre.

At a general meeting of the Royal Institute of Painters in Water Colours, Piccadilly, held last week, the following were elected members:—Messrs. W. Lee Hankey, James S. Hill, John Pedder, G. Straton Ferrier, and J. Finnemore.

Mr. J. B. Dunn, of the firm of Dunn and Findlay, architects, Edinburgh, and Mr. George H. Law, of *The Scotsman*, sailed on Saturday in the Cunard steamer *Lucania* from Liverpool for New York, their object being to visit some of the chief newspaper offices and other buildings in the United States in connection with the preparation of the plans for the new offices of the *The Scotsman*, and the rebuilding of North Bridge-street and Market-street, Edinburgh.

It was announced at the meeting on Saturday of the National Union of Teachers that a site had been found at Wimbledon for the new orphanage which is to be built in the place of the one at Peckham. The ground will cost £4,300, which will be raised by the London Teachers, while Mr. J. Passmore Edwards has promised to provide the building at a cost of £5,000.

Up to the end of 1897 the total expenditure of the harbour works at Colombo, Ceylon, amounted to Rs.17,875,855, of which Rs.5,529,916 have been incurred on the two additional breakwaters commenced in 1894. Before the completion of the works, which comprise a graving dock and patent slip, a coaling depot, and the three breakwaters inclosing a harbour of one square mile in extent, the total outlay is expected to reach Rs.2,500,000. The sterling debt of the colony on account of these harbour constructions will be £1,300,000. It will probably be 1902 before everything is finished.

The Floods Prevention Bill, which gives further powers to county councils with a view to the prevention of floods and other damage arising from rivers or water-courses, passed through committee in the House of Lords on Tuesday, with an amendment introduced on the motion of Lord Zouche of Haryngworth, providing that, in case of any injury done to the owner and occupier of land, or either of them, under the Act, full compensation should be made by the county council to both—that is to say, that one should not be compensated to the exclusion of the other.

#### COMPETITIONS.

CARSHALTON.—The Metropolitan Asylums Board, at their meeting on Saturday, received a report from their works committee stating that, as instructed by the Managers on June 19, 1897, they invited fifteen selected firms of architects to submit plans for certain portions of the Southern Hospital proposed to be built at Carshalton. Of these fifteen firms, ten only responded to the Managers' invitation, and sent in designs which the committee considered most creditable to the authors, and of great uniformity of merit. As the result of the examination of them, in which they had the assistance of the assessor, Mr. Henry Currey, F.R.I.B.A., they had selected three as most worthy, and recommended that "premia" of £150, £100, and £50 be awarded respectively to the authors of the designs marked A, I, and J, this being the order of merit in which such plans have been placed." Mr. R. M. Hensley, chairman of the committee, in moving the adoption of the report, stated that the committee were unanimous in recommending that the premiated plans be placed in the order given in the report, and as the sealed envelopes had not been opened, and all designs were lettered in order of receipt, they did not yet know who were the authors of the successful plans. As to the probable outlay, plan A, the one placed first, was, according to the cubical contents of the buildings, likely to be the least expensive, although that fact had not influenced the assessor or the committee in their choice. Plan A cubed out at about five million cubic feet, and plans I and J at a little over six million cubic feet. The three premiated competitors all set different values on the work, the author of A having 7d. as a basis, I 8d., and J 9d. per cubic foot; but if they assessed the plans at a uniform rate of 8d. per foot, A would cost £169,000, I £200,000, and J £203,000. Even 8d. a cubic foot was, however, much too low a figure to select as a basis of cost; but if they raised it to 10d., the outlay would be £212,500 on A, about £250,000 for I, and some thousands of pounds more for J. To these figures must be added the architect's charges, engineering expenses, the making of roads, fences, and internal divisions, so that members need not be surprised if the final cost exceeded a quarter of a million. The hospital proper would probably cost £150,000. Mr. E. Monson, C.E., said he regarded the scheme as an entire waste of money, for no draughtsman at three guineas a week could have drawn up the plans for such a building. He did not approve of the plan by A, as the buildings were located too closely together, and the best site obtainable had not been selected. He moved that plan I be awarded the first premium. The amendment, not being seconded, fell to the ground. Replying to Mr. W. L. Burle, Mr. Hensley said the cost per bed would be about £350. The report having been adopted, the seals of the envelopes were broken, and it was announced that the authors of plan A were Messrs. Treadwell and Martin, 2, Waterloo-place, Pall Mall; of plan I, Messrs. Pennington and Sons, Hastings House, Norfolk-street, Strand; and of plan J, Messrs. Newman and Newman, 31, Tooley-street, London Bridge.

TIPTON.—The first prize of £25 in the public competition for the best plan for laying out the New Victoria Park at Tipton has been unanimously awarded to Messrs. William Barron and Son, Elvaston Nurseries, Borrowash. Their plan shows a lake about three acres in extent, cricket and recreation grounds, lawn-tennis grounds, bowling-green, band-stand, shelters, &c. They also furnish plans for lodge, entrance-gates, ornamental fencing, &c. The park is 33 acres in extent. The second prize was awarded to Mr. John Perry, architect, Tipton. There were ten competitors.

The Chancellor of Truro diocese has at length granted a faculty for rebuilding the tower of the parish church of Liskeard, on condition that at least £2,500, including a sum of £1,000 receivable from the Peddar Legacy, has been raised towards the estimated outlay, £3,500.

The aggregate realisation at the Auction Mart last week was £207,000, an excellent result, taking into consideration the fact that the attractions of the Ascot Meeting were not without influence on the market. Last year the amount registered for the corresponding period was £133,800, so that the ground lost in the month of May is being rapidly made up. This week has been one of the busiest of the season, the supply of properties of all descriptions having been much beyond the average.

#### ARCHÆOLOGICAL.

PETERBOROUGH.—A discovery of great interest has been made at the Peterborough Cathedral restoration works during the past week. For some time excavating work has been in progress for the purpose of underpinning the foundation of the north-east corner walling of the eastern chapel, which has shown marked signs of subsidence. The foundations of this chapel were found to be partly built on the ancient Saxon wall (*circa* 800), which was a considerable surprise, and altogether a valuable archaeological find, especially as it had been considered that the building was in the vicinity of the old Saxon ditch, which bounded the original Medehampstead, or ancient Peterborough, and that the foundations having been placed within the area of the ditch accounted for the subsidence. During the past week, however, all doubts both as to the direction of this ancient waterway, and even of its locality, have been set at rest. At the depth of about 12ft. the rock was found to have been cut right, though to the underlying clay in a direction running due east and west. Instead of there being evidences of mud, or any deposit of an alluvial character, the ditch was seen to contain a layer of about 2ft. of peat ashes. The ditch was found to empty itself through a well-defined pass in the Saxon wall. It evidently ran in a line with the present north wall of the cathedral, and here again has been found a reason for the subsidence of the northern wall of the great fabric itself. Data and drawings are being gathered by the architect's clerk of the works, Mr. J. T. Irvine, which will form the subject of a paper to be read during the approaching Archaeological Congress in the city. The Saxon tombstones *in situ* in the north transept have, by this discovery of the Saxon ditch, been relegated to the period of the *secund* Saxon church at Peterborough, as otherwise they would have been southward of the ditch, whereas they are well on the north side.

The British School on Smethwick Hill, Falmouth, has been acquired by the local school board, and has been altered and greatly enlarged. Mr. A. E. Skinner, Falmouth, was the builder.

It was formally stated at the last meeting of the Museums Committee, that the Queen had expressed her desire to lay the foundation-stone of the new Science and Art Buildings, which are to be erected at South Kensington, at an estimated cost of £80,000. We illustrated Mr. Aston Webb's designs for the buildings, which were selected in competition nearly seven years ago, in our issues of August 7 and 14, September 11, and November 20, 1891.

In our notice last week of the opening of the University College Extension, Reading, by the Prince of Wales, we should have mentioned that the constructional steelwork was executed by Messrs. Mark Fawcett and Co., of 50, Queen Anne's-gate, Westminster, and that the floors are built upon Messrs. Fawcett's patent system.

A new tramway has been opened connecting Fleetwood with Blackpool, on the electric haulage system. The length of the line is ten miles, and it now completes a chain along the Lancashire sea coast of fully 25 miles. It is proposed to extend the tramway along the Ribbles Valley to Preston, which will make the line the longest in the kingdom.

The laying out of the Victoria Gardens at Truro, which are to serve as the city's permanent memorial of the Queen's Diamond Jubilee, has been completed under the direction of Messrs. Henderson and Son. The formal opening took place on Monday.

A new church is in course of erection in the parish of St. Mary Magdalen's, Accrington. It is intended to accommodate 530 persons, and will cost £7,800. At present it is proposed to proceed only with the chancel and eastern portion of the nave, and leave the tower, spire, and west extension for a subsequent effort. In 1891 a new school was erected adjoining the church site at a cost of £3,200. It has been decided to lay the foundation-stone of the new church to-morrow (Saturday).

The Victoria Buildings in Silver-street, Bury, Lancs, have just been completed. The block comprises four shops and fourteen sets of offices, and has been erected by Mr. C. Brierley, contractor, the architect being Mr. J. D. Mould, of Bury and Manchester.

A stained-glass window has just been placed in South Wingfield Church, Darby. It has been erected by Messrs. Peter and William Summerton, of Leeds, in memory of their parents, who for many years lived in the village. The window represents our Lord Jesus Christ as the Consoler of Mankind, and has been designed and executed by Messrs. Powell Bros., of Park-square, Leeds.

## Building Intelligence.

**BENWELL, NEWCASTLE-ON-TYNE.**—A new building estate has been opened out at Benwell to the north of the parish church. This estate is being developed by the Tyneside Land and Property Corporation, Limited. The first contract for an entire street, amounting to several thousand pounds, has been let to Mr. J. Hutchinson, of Elswick-road, Newcastle. The work of construction will be supervised by Mr. C. T. Marshall, architect, of Northumberland-street, from whose plans the houses are being erected. In addition to the above, plans are being prepared for blocks of shops and buildings of a public character by Messrs. Dunn, Hansom, and Fenwick, architects, Eldon-square. The directors of the company have given instructions to Mr. C. T. Marshall to prepare the plans of a large building to be erected opposite the church, at the corner of the main turnpike and Charlotte Pit-road. Bricks are about to be made on the site, machinery and plant having been laid down by Mr. Burnett, of Scotswood, for this purpose. The surveyor to the estate is Mr. Welton, of Hexham, who has laid out the whole in streets, the drainage being carried out also under his direction.

**EXETER.**—The formal opening of the new offices, &c., erected for the Exeter Gas Light and Coke Company on the site of houses formerly known as Nos. 11 and 12, East Southernhay, took place on Tuesday week. The front elevation is composed, in the lower story, of Doulling and red Corsehill stone, with polished granite columns at the entrance. The upper story is of Doulling and red Gloucester stone, the roof being of Broseley tiles. There is considerable grotesque and floral carvings on the front, the work of Mr. E. T. Rogers, of St. Sidwell's-street, Exeter. A vestibule, with oak fittings and ceiling of the same material, opens into a hall some 24ft. in length, and contains a tiled chimney-piece. On the left is the general office, and opening from it is the strong-room. Straight through from the main entrance is a showroom 40ft. by 25ft., and from it a lift is provided for the conveyance of goods to a smaller room on the upper floor. On the ground floor are the outdoor inspector's office, lavatories, and stores. There is a mezzanine floor, containing stores for stationery, &c., and a broad staircase leads to the waiting-room. On this floor are the board-room and secretary's office, separated by sliding doors, and which, when thrown into one room, give an area of 54ft. by 20ft. The showroom on this floor is about 24ft. square, and there are also three rooms for use in connection with the tests of and experiments on the company's products. The building is provided with wrought-iron gasfittings, with incandescent lights. The floors of the hall and general office are tiled, the remainder of the ground floor being laid with wood-block flooring, and dadoes are fitted round all the rooms. Behind the main building are two cottages for the overseers, large workshops, and stores, approached by a wide cart entrance; they are of a substantial character, and, with the rest of the building, were erected by Messrs. Ham and Passmore, from designs by Mr. Dobell.

**IPSWICH.**—The memorial-stones of a Wesleyan People's Mission Hall were laid in Stoke-street, Ipswich, on Wednesday in last week. Some time ago a syndicate was formed for the purpose of improving Stoke-street at the southern end of the bridge leading across the river into Ipswich, and old cottages were pulled down and the road made wider. The land that was left is that now possessed by the Wesleyans. The buildings in immediate contemplation are a central hall to accommodate 800 persons, a second and smaller hall to hold 250, with class and retiring rooms. The small hall forms with the larger an L-shaped pile, and later on a wing is to be added on the other side. When thus complete, the total frontage to Stoke-street will be about 170ft. At the rear also it is proposed, when funds are available, to build schoolrooms. The larger of the two halls now to be built will measure 56ft. by 46ft., and steps will lead from the porch to a gallery over the hall, a balcony over the street, and a classroom 21ft. by 13ft. At the other end will be a platform 11ft. 6in. by 24ft., at the back of which are two retiring-rooms and a classroom. The small hall will be 22ft. 6in. by 38ft., and will also have retiring and classrooms at the back. The whole will be of red brick and tiled. The halls are to be plastered, with dados, and floored

with wood. Messrs. Eade and Johns, of Ipswich, are the architects, and the builder is Mr. Edgar Catchpole of the same town.

**UNIVERSITY COLLEGE HOSPITAL.**—The Prince and Princess of Wales visited this institution on Tuesday, to lay the foundation-stone of the new edifice, Sir J. Blundell Maple having undertaken to rebuild the hospital at a cost of £100,000. The building is already rising on the quadrilateral area bounded by Gower-street, Grafton-street, Huntley-street, and University-street. The material is red brick, with terracotta dressings, and the plan is that of a diagonal cross. A special feature, for which Dr. Poore is responsible, is the isolation of each ward. The arms of the cross will be separated from the central block, with which communication is to be established by means of bridges. Corridors and staircases are thereby abolished from the interior of the hospital. The plans have been prepared by Mr. Alfred Waterhouse, R.A., and are designed to give accommodation to 300 patients. We illustrated the new hospital in the BUILDING NEWS for May 8, 1896.

**SLEDMERE.**—The church of St. Mary at Sledmere, on the Yorkshire Wolds, was consecrated on Friday by the Archbishop of York, having been rebuilt at the sole expense of Sir Tatton Sykes. The church is entirely new, excepting the 14th-century tower, which was the only part of the Mediæval building left when, about the middle of the last century, it gave way to a plain structure. The lines of the original church having been discovered during the removal of the Georgian building, it was determined to erect the new church on the same ground plan as the Mediæval one. It now consists of a nave of five bays, with north and south aisles and a chancel. The vestries are on the north side of the chancel, with the organ-chamber over the choir vestry. The style adopted is 14th-century English-Gothic. The lofty nave arcade has richly moulded columns and arches, with moulded caps and bosses. The aisles are vaulted in stone, the cells of the groins being filled with clunch, and the ribs and bosses being in red stone throughout the interior. Nave and chancel roofs are carried from west to east at one unbroken level, and are constructed of oak, while the ceilings are panelled in oak with carved bosses at the intersections of the main timbers and ribs. In the windows, tracery of the earlier type of the Flowing Decorated has been used, the great east window being in five lights. The chancel windows are entirely filled with stained glass. At present the nave windows are only temporarily glazed; but it is Sir Tatton Sykes's intention to fill these with stained glass similar to that in the chancel. A feature of the church is the stone reredos at the east end of the north aisle, rising nearly to the height of the vault; while immediately above the high altar is a reredos carved in wood representing the Crucifixion, with the Virgin and St. John and the Apostles on either side. The floors of the church are of Irish marble. The tower has been restored, and a parapet added to the original design. On the parapet are shields bearing the arms of families that have at different times been connected with the estate. The whole of the exterior of the church is executed in Whitby stone. Mr. T. Moore, of London, was the architect, and the whole of the work has been carried out under his supervision. The contractors for the work were Messrs. Thompson, of Peterborough, whose representatives have been Mr. Geo. Mills and Mr. J. Baker. The marble flooring is from the works of Mr. R. Collis, Kilkenny.

**SOUTHWARK.**—A special service was held on Wednesday in the Collegiate Church of St. Saviour, Southwark, on the occasion of the unveiling of the stained-glass window in memory of the late Prince Consort, the starting of the new clock and chimes, and the unveiling of the memorial windows to Edward Alleyn and Elizabeth Newcomen by the Duke of Connaught, and the dedication of the pulpit and lectern by the Bishop of Rochester. The three windows were all designed by Mr. C. E. Kempe. That in memory of the late Prince Consort—the gift of Mr. Frederick L. Bevan—is in the north transept, and comprises four subjects—Gregory the Great, Ethelbert, Stephen Langton (Cardinal Archbishop of Canterbury), and William of Wykeham, Bishop of Winchester (“architect, statesman, and father of the public school system of this country. He was ordained acolyte, sub-deacon, and priest, 1362, in the

Chapel of Winchester House, which adjoined the west end of this church.”) The memorial window to Edward Alleyn, which is in the south aisle, was given by the governors and old scholars of Dulwich College, which he founded in 1619. Alleyn was also one of the Corporation of Wardens of St. Saviour's in 1610. The lowest panel of the window is a figure of Charity, and in the middle panel Alleyn is seen reading in the college chapel the charter and constitution of his foundation in the presence of Lord Chancellor Bacon, Lord Arundel, Inigo Jones, and others. His portrait occupies the head of the window. The Elizabeth Newcomen memorial window is in the south transept. In allusion to her name, St. Elizabeth occupies the base of the central light as the leading figure, above which is St. John the Baptist, supported by Elijah and Malachi. Elizabeth Newcomen was “a generous, educational, and charitable benefactress of the parish.” She was buried in the church on November 20, 1675. The new clock, which is the gift of Sir Frederick Wigan, has been designed and manufactured under the direction of Mr. H. Hardwicke Langston, A.R.I.B.A., at the works of Messrs. Gillett and Johnston, of Croydon. It is constructed to show the time on four faces, each 9ft. 6in. in diameter, and the quarters are chimed on bells Nos. 6, 7, 8, and 11, the hours being struck upon the 12th, or tenor bell, which weighs 52cwt., by a hammer weighing 96lb. The pulpit is of carved oak, and the lectern is of bronze and over 6ft. high: both are special gifts.

**SPRINGBURN, GLASGOW.**—Wellfield U.P. Church, Springburn, the foundation-stone of which was laid on Saturday, is at the corner of Balgray-hill and Murdoch-street, and extends back to Sutherland-street. As there is a difference of over 27ft. between the levels of the back street and Balgray-hill, the hall has been placed facing Sutherland-street on the higher level, and entering from Murdoch-street, the rooms, vestry, session-house, &c., on an intermediate level, while the church occupies the corner of Murdoch-street and Balgray-hill, with entrance from both streets. Internally the church is planned with nave and side aisles, separated by moulded stone arches carried on splayed stone piers. There are galleries at sides and end, but the galleries are kept back behind the line of the stone piers, allowing these to be carried up in an unbroken line. Above the piers attached stone shafts are carried up, terminating in carved caps, from which spring the principal roof couples. The pulpit will be placed under a wide stone arch at the eastern end, and on each side, under smaller arches, an organ-chamber is arranged. The hall is 54ft. long and 28ft. broad, and there are two large classrooms, which can be opened into one, forming a lesser hall for 100 persons. The style is Late Decorated, and the principal feature externally will be the tower and spire, which will be over 100ft. high. The lower stage is carried up square to the belfry chamber, where the plan becomes octagonal, with projected buttresses at angles. The mason-work is in red sandstone. The number of sittings provided is 808, and the cost will be about £7,200. The architect is Mr. John B. Wilson, Glasgow, and the contractors are:—Mason, H. Nelson and Co.; wright, Thomas Brown; slater, Thomas Muir; plasterers, J. and A. Williamson; plumber and gasfitter, Thomas Munro; glazier, Joseph Miller; and painter, A. Stirling—all of Glasgow.

**SUNDERLAND.**—Close to Roker Park is the scene of large alterations in the shape of a new football field for the Sunderland Association Football Club. The entrances are formed on all sides, making a total of fourteen entrances and seven exits, also a private entrance to Press-box, built in the centre of the west stand. The pitch is 111 yards by 71 yards, turfed, levelled, and drained with touch space 7ft. outside. Beyond this, again, is the players' running and training track 12ft wide, levelled and rounded at the corners; this is inclosed by a wrought-iron barrier. The stands are arranged in the raking fashion, allowing all spectators to see over the ground, a special feature having been made at the corners. The stands accommodate 26,000 people, and the slope in front will stand comfortably 8,000 people, making a grand total of 34,000 people. The grand-stand is 71 yards long, situated on the east side, and will seat over 2,000 people. This stand is heightened in front to 7ft. on concrete and brickwalling, so that the spectators' heads of those standing on the slopes will not interfere

with those seated behind. The entrance to this is by a stair to a 4ft. wide balcony in front. There are special filling staircases to backs of all stands. The work has been planned by, and is now being carried out under the supervision of Messrs. Wm. and T. R. Milburn, architects, 20, Fawcett-street, Sunderland, the general contractor being Mr. J. W. White, Chester-road, Sunderland.—There are now in course of erection large brewery extensions at the Monkwearmouth Brewery, belonging to Messrs. James Deuchar, Limited. The new building is situated near Sunderland Bridge. It is five stories in height, composed of two large cellar floors, one barley floor, two malting floors, and kiln floors. The building, which is 170ft. long by an average of 60ft. wide, covers an area of 912 square yards, is built of brick, plain, but substantial. The premises have been planned, and are now being carried out under the supervision by Messrs. Wm. and T. R. Milburn, architects, Sunderland, the contractor being Mr. T. P. Shaftoe, also of Sunderland.

### CHIPS.

The parish church of South Wingfield, Derby, has just been further beautified by the addition of a stained-glass window. The work has been designed and executed by Messrs. Powell Bros., of Park-square, Leeds.

The Nuneaton Urban District Council at their last meeting received seven tenders for the laying of mains along Plough Hill. The figures named were £286, £379, £508, £526, £550, £810, and £818. The margin between the highest and lowest caused much amusement. The matter was referred to the waterworks committee.

The foundation-stone of the Central Technical Schools for Liverpool will be laid on Friday next, July 1st. The schools occupy a commanding position bounded by William Brown-street, Byrom-street, and Clayton-street, and the building work is now being carried on with the utmost expedition. All the foundations of the structure are down, and the walls have reached the street level. The plans of Mr. E. W. Mountford, F.R.I.B.A., of London, were adopted by the committee, having been selected in competition; the contractors are Messrs. Henshaw and Son, Chatham-street; and the clerk of the works is Mr. James Scales. The cost will exceed £90,000.

The Rev. F. W. Mortimer, Vicar of Darlington and Rural Dean, has consecrated a new carved oak reredos, in the parish church at Middleton-in-Teesdale, as a memorial of the late rector, the Rev. John Milner, M.A., who was rector for twenty-two years. The subject is "The Good Shepherd," and it is the work of Messrs. Harry Hems and Sons, of Exeter.

At Liverpool, on Tuesday, Mr. T. H. Ismay, head of the White Star Line of steamers, laid the foundation-stone of a building which is being erected by the People's Houses Company, Limited, on the model of the Rowton Houses in London. The building is situated at Bevington Bush, where many seafaring people reside. The new building will provide for 650 at a uniform charge of sixpence per night, with full access to all conveniences of the place.

The recent additions to the collection in the Corporation Art Gallery of Birmingham—the picture of "Scarborough," by Mr. Henry Moore, R.A., given by Mr. James R. Holliday, and the "Piazza of St. Mark's, Venice," given by Sir John C. Holder, Bart.—are now hung in the gallery, as is also the portrait of the late Mr. Edmund Tonks, by Mr. Frank Holl, R.A. With them is another notable work, the "Val d'Aosta," by Mr. Brett, A.R.A., lent by Mr. Severn; a drawing which, when it was exhibited in the Royal Academy forty years ago elicited from Mr. Ruskin unreserved commendation.

The Board of Trade have issued an order granted by the Light Railway Commissioners, and now confirmed by them, authorising the Great Western Railway Company to construct the Wrington Vale Light Railway, which was originally promoted by an independent company. The railway authorised by this order comprises a line nearly 6½ miles in length, commencing at the Congresbury Station on the Cheddar Valley branch of the Great Western system, and passing thence through Churchill, Wrington, and Burrington, to its termination at Blagdon, with branches to the Bristol Water Works Company, and to a point known as Langford Lane. The time granted for the construction of this railway is three years from the 18th of last March.

The Billericay Rural District Council have resolved to apply to the Local Government Board for sanction to borrow £5,000 for a joint sewerage scheme for the parishes of Shenfield and Hutton. The scheme has been designed by Messrs. Bailey Denton, Son, and Lawford, of Westminster, and will be carried out immediately.

## Engineering Notes.

SHREWSBURY.—Alterations which have been in contemplation for over thirty years have been commenced at Shrewsbury Station, and will involve an expenditure by the joint railway companies of something like £300,000. The Great Western Railway from Shrewsbury to Chester was opened in 1848, and the station was built on the assumption that the traffic would amount to about forty trains per day. At present there are over two hundred passenger trains alone to be dealt with, and the goods trains number from two hundred and fifty to three hundred. At the Birmingham end of the station the viaduct which crosses the Severn is to be widened to three times what it is at present, for what is practically a new bridge will be erected on either side of the present structure. In the centre of the river will be a pier of cylinders, from which will run a one-span arch to each bank, of 100ft. between the piers. For this work the Cleveland Iron Co. have entered into a contract for about £160,000, which includes other extensions at the same end of the station. At the other end, where the Chester and Crewe lines branch off, there will also be extensive improvements. The bridge, which at present crosses Castle Foregate, is 80ft. wide, and its width will be increased to 217ft.; but there will be an open space affording light for street traffic. A number of shops and private houses are to be demolished. Cross-street will be covered by another widened bridge, and Howard-street will be "moved" lower down the Foregate, and the gradients improved.

New premises for the local branch of the Devon and Cornwall Bank are about to be erected at Honiton on the site of the present East Devon Stores, opposite the Dolphin Hotel, from plans by Messrs. Ralling and Lonar, of Exeter.

At the Council House, Bristol, on Friday, Mr. W. O. Meade-King, C.E., one of the inspectors of the Local Government Board, held an inquiry with reference to an application by the sanitary authority to borrow £10,000 for purposes of wood-paving, £2,500 for the new sanitary depot in Albert-road, and £226 for sewage works in Redcross-street.

The National Trust for Places of Historic Interest or Natural Beauty is in the field for the purchase of Tintern Abbey. It is suggested that a number of local gentlemen should purchase the Abbey and Monmouth and Raglan Castles, pending the promotion of a Bill in Parliament enabling the Monmouth County Council to acquire these historic buildings.

The Chester-le-Street Rural District Council have instructed Messrs. D. Balfour and Son, of London and Newcastle, to report on a scheme of main sewerage for Chow Dene, Wrekenton, Eighton Banks, and Team Colliery, in the township of Lamesley, to be connected with the western sewer of the corporation of Gateshead.

The scheme of water supply submitted by the Easington Rural District Council for Wingate Mill, Wingate-lane, and High Wheatley Hill has been officially approved by the Local Government Board. It is proposed to obtain the water from the Kelloe Winning pumping-station of Messrs. W. Scott and Co., Ltd., where it is obtained from the sand-feeder underlying the limestone, and will be pumped into a tank by a forcing set of pumps attached to the main pumping-engine. The analysis certifies the water to be of excellent quality. After reaching the first tank, the water will again be pumped into an elevated storage tank to be erected on the highest point in the district at Wingate Mill, with capacity equal to several days' supply, from whence it will be distributed in cast-iron mains over the district. The engineers are Messrs. D. Balfour and Son, of London and Newcastle.

The Gates Memorial Fountain in the Market-place at Peterborough was inaugurated on Tuesday week. It takes somewhat the character of the old Eleanor Crosses. It is a slender Gothic structure, over 80ft. in height, octagonal in plan, and in three stages. The lower stage carries the basins, and the taps are under a traced canopy on four sides. The next stage is panelled, having buttresses at the angles, carried on carved corbels, and the heads are filled in with tracery. Mr. James Ruddle, of Peterborough, is the architect, and Messrs. Roberts, of Stamford, carried out the work.

The Improvements Committee of the London County Council, having considered a scheme for the embankment of the Thames from the Victoria Tower Garden, Westminster, to Lambeth Bridge, and the widening of Millbank-street, have issued a report on the progress made, but do not at present recommend the adoption of any particular scheme.

### PROFESSIONAL AND TRADE SOCIETIES.

THE ARCHAEOLOGICAL AND ARCHITECTURAL SOCIETY OF DURHAM AND NORTHUMBERLAND.—The second meeting for the year 1898 is being held yesterday (Thursday) and to-day at Levens Hall, Cartmel Priory, and Furness Abbey. Members drove yesterday, on arrival at Heversham Station, to Heversham Church, and afterwards proceeded to Levens Hall, the seat of Captain Bagot, M.P. The party then proceeded to Cartmel, where the fine church of St. Mary's Priory was examined, and they stayed overnight at Grange-over-Sands. This (Friday) morning members will take train to Furness Abbey, founded in 1127, where the remains of the abbey will be described by Mr. C. C. Hodges, F.S.A.

SOCIETY FOR THE PROTECTION OF ANCIENT BUILDINGS.—The annual meeting of this society was held on Thursday afternoon in last week, in the meeting-room of the Society of Antiquaries, Burlington House, under the presidency of the Bishop of Bristol. Lord Balcarras moved the adoption of the report, and, in doing so, said he thought the society had done a great deal during the last year. It would be almost a truism for him to point out that many interesting and valuable buildings of bygone times had been restored—or, in other words, destroyed—without the efforts of the society being able to effect any protection whatever; but they must not relax their vigilance and energy for a moment. If they could persuade more persons to act as local correspondents of the society, it would certainly save the society much trouble, and in every way expedite its proceedings. Mr. Lovibond seconded the motion, which was agreed to. Mr. H. E. Luxmoore read a paper on "Our Purposes and Prospects." The Bishop of Bristol, in moving a vote of thanks to the lecturer, said that they had to face the fact that in England we were terribly crowded. In former times there was more room for building; now, time after time, it was brought to his notice that a larger number of persons had to be got on to a given area than before, and that could only be done by increasing the number of stories in a building. The higher they went on a certain frontage the worse and worse the effect usually was. He must say, however, that when they went into the City of London on a fine Sunday afternoon, when they could really stand and look at things, they found out that beautiful buildings, very striking buildings indeed—buildings that would be no discredit to Venice or to Florence—had been put up in the City of London in quite recent times, and many of the architects of those buildings did not get the credit for their work. That was an answer to a good many of the criticisms with regard to the removal of old buildings. At the same time, he expressed the fullest sympathy with the objects and principles of the society.

The work of rebuilding the barracks at Winchester is to be proceeded with at once, and the first contract is placed in the hands of a Putney firm. The undertaking is that the foundations should be completed within the next six months.

At a special meeting of the Aston School Board, the tender of Mr. John Bowen, of Balsall Heath, amounting to £19,486, has been accepted for the erection of the new higher-grade school, pupil teachers' centre, deaf school, and caretaker's house, on the site in the Whitehead-road. The architects are Messrs. Crouch and Butler. With the purchase of the site and other charges, the total cost will be about £23,000.

At the last meeting of the town council of Stockport a statement was presented showing the cost of the main intercepting sewer and sewage outfall works up to date as £139,764. It was explained that this was £44,760 in excess of the original estimate, or 47 per cent., and the scheme was not more than two-thirds finished. It is expected to cost £200,000.

The Colwyn Bay Pier Bill, to confirm a provisional order made by the Board of Trade, was certified for second reading on Monday by the examiners of the House of Lords for proof of compliance with the standing orders. The object of the order is to authorise the Victoria Pier and Pavilion Company to construct and maintain a pier at Colwyn Bay, opposite the London and North-Western Railway subway, and extending seaward in a north-easterly direction for 1,000 yards. The company are also authorised to construct on the pier a tramway, pavilions or assembly rooms, concert-rooms, aquaria, shops, saloons, bazaars, kiosks, reading, refreshment, and other rooms, swimming and other baths, &c.

CONTENTS.

Competition Designs for Fever Hospital at Carshalton	875
Model Specifications.—XVIII	875
Royal Institute of British Architects	876
The Proposed Central Street from Holborn to the Strand	878
Electric Lighting Notes for Architects.—XXV	880
English Art in the Eighteenth Century	883
Obituary	883
Competitions	884
Archaeological	884
Building Intelligence	885
Engineering Notes	886
Professional and Trade Societies	886
The Building News Directory	ix.
Our Illustrations	887
The Sanitary Institute	887
An Architect Tried for Manslaughter	887
Fountain, Market Drayton	888
Intercommunication	906
Parliamentary Notes	906
Legal Intelligence	907
Our Office Table	907
Meetings for the Ensuing Week	908
Trade News	908
List of Competitions Open	909
List of Tenders Open	909
Latest Prices	911
Tenders	912

ILLUSTRATIONS.

- ARMY AND NAVY MANSIONS, VICTORIA-STREET, S.V.—
- TOMB AT BURTON LAZARS, LEICESTERSHIRE.—MURAL MONUMENT, NEWBOLD.—STUDIES OF ANIMAL LIFE.—
- HOUSE AT MEDMENHAM.—COTTAGES AT WALTHAM ABBEY.—FOUNTAIN AT MARKET DRAYTON.

Our Illustrations.

ARMY AND NAVY MANSIONS.

This building comprises two blocks of residential flats of seven stories, situate at the corner of Victoria-street and Francis-street, Westminster, S.W. It is erected in red brick with Portland stone dressings, and is fireproof construction throughout. The buildings were erected and carried out by Mr. W. Goodwin, builder, of Hatton Garden, at a cost of £40,000, from the designs and under the superintendence of the architect, Mr. Chas. J. C. Pawley, of Victoria-street. The red facing-bricks were supplied by Messrs. Lawrence and Sons, and the lifts by Messrs. Waygood and Messrs. Medway.

TOMB, BURTON LAZARS.

The yard of the small, but rich, church of Burton Lazars is dotted over with many fine tombstones of the late 17th and the early 18th century, although none, perhaps, equal in importance the subject of the sketch, which is designed in the style of the Renaissance. The details of the carving are very charming—unusually so, for the date—the two globes in particular, representing the Six Days of Creation, being excellent. The figures at either end are unfortunately somewhat mutilated.

MURAL MONUMENT, NEWBOLD.

This monument of carved and coloured marble is built into the wall of the south aisle of Newbold-on-Avon Church. It is in the style of the Late English Renaissance. The top portion commemorates Edward Boughton and his wife, the latter a member of the famous Catesby family. The lower portion is to the memory of William (the son of above-mentioned Edward Boughton) and his wife. In each case the children of the respective parents are represented, the boys being placed on one side and the girls upon the opposite, this being quite the usual custom in monuments of the period. The children are also usually named upon the inscription (as in this case) or upon separate scrolls under each child. The top portion is decidedly superior in design and execution to the lower, especially in the decoration of the pilasters on either side. The method of treatment also differs considerably; in the upper the background is cut back and coloured, leaving the ornament light upon dark; whilst the lower pilasters have inlaid strips of grey marble projecting beyond face of pilasters—a remark also applying to the heart at the bottom of the structure. It is also interesting to note the ruffles around the lady's neck in the upper as compared with the more severe style of the lower portion. Evidently, then, on account of the difference of ornament, the lower part was added subsequently to the upper, the two forming one complete monument.

STUDIES OF ANIMAL LIFE, TREATED FOR DESIGN.

This sheet of National Silver Medal drawings, by Mr. H. Brownword, presents in an eminently interesting way several very decorative sketches of picturesque birds' heads, familiar enough, of course, as natural history specimens, but so represented as to indicate suggestive treatments for all kinds of applied design. The smaller studies illustrate the birds full-length in each case, and show characteristic attitudes of the examples chosen for representation more in detail by the larger drawings. The habits of the birds themselves, and the uses to which their peculiarities are adapted in nature, are in this way very usefully indicated for reference.

HOUSE AT MEDMENHAM.

The drawing illustrated was the first design for a house now being built for Mr. Hudson Kearley on the high ground overlooking the river between Great Marlow and Medmenham. The materials are red brick with Chipsham stone dressings, and Whitland Abbey slates. On the south side is a loggia with columns and a gallery above. Mr. Reginald Blomfield, of New Court, Temple, is the architect, and Messrs. Holloway Brothers are the contractors for the work. The drawing is exhibited at the Royal Academy.

COTTAGES ON THE COLVIN ESTATE AT WALTHAM ABBEY.

The drawing shows some of the cottages erected for Mr. R. B. Colvin on his estate at Waltham Abbey, to supply the long-felt want for convenient and modern homes for the artisans in the neighbourhood. The group of four cottages in the foreground is pleasantly situated alongside the main road, from which they are well set back, thus allowing scope for a front flower garden. They are built with red brick facings to ground-floor, the upper story being faced with rough-cast, and the gables constructed of half-timber work, and the roofs are covered with plain tiling. In the background is shown one pair of semi-detached cottages. These pairs of cottages have less accommodation than the group of four, and are suitable for small families, and are plainly built with red brick facings on ground-floor and rough-cast upper story, with a plain hipped roof covered with pantiles. All the bricks and tiles were made on the estate. The architect is Mr. F. W. Adams, of Finsbury Circus-buildings, 18, Eldon-street, E.C., who is architect to the estate.

CHIPS.

Sanction has been given by the Local Government Board to the urban district council of Broadstairs and St. Peter's for a loan of £17,800 for sewerage.

The London County Council passed, on Tuesday, a resolution to serve a notice on the London Tramways Company to acquire 18½ miles of their system. This comprises the lines running from Westminster and Blackfriars Bridges to Greenwich and Brixton.

At Cattedown, Plymouth, the western section of a new church has been built from plans by Messrs. Weblin and De Boinville, of Plymouth. The present portion of the building is seated for 200 people.

A large clock, with quarter chimes, has just been erected in the parish church of Uppingham. Rutland, by Messrs. John Smith and Sons, Midland Clock Works, Derby.

The foundation-stone of the cottage homes now being erected for the Aston Board of Guardians from plans by Messrs. Franklin, Cross, and Nichol, of Birmingham, will be formally laid on the 20th July.

The directors of the Metropolitan Railway Company have decided to construct the proposed new station between King's Cross and Farringdon-street. It will be placed at the junction of Rosebery-avenue and Farringdon-road, and will be a great convenience for those who wish to reach Clerkenwell from the City or West End. Under the Bill now before the House of Lords, and which has already passed all stages in the House of Commons, the directors propose to expend some £80,000 in temporary measures of ventilation pending the ultimate adoption of electrical traction in lieu of steam.

At a general assembly of the Royal Society of British Artists, held last week, the following were elected, viz.:—Messrs. Cecil Burns, Martin Bruce, Ralph Headley, and Leon V. Selon.

The Exhibition of French Art at the City Guildhall continues to draw unprecedented numbers, over 50,000 having visited it during the past fortnight. This number shows an average of 420 per hour on week-days, and 630 per hour on Sundays.

THE SANITARY INSTITUTE.

At an examination for sanitary inspectors held under the auspices of the Sanitary Institute of Great Britain, in Leeds on June 10 and 11, 1898, 36 candidates presented themselves. The following 20 candidates were certified, as regards their sanitary knowledge, competent to discharge the duties of inspectors of nuisances:—Edwin Ainley, Huddersfield; John Robert Bell, Snape; Tom Biker, Bardoldswick; George Henry Canby, Keighley; Edwin Carratt, Leeds; James Coupe, Bramley, Leeds; James Samuel Cromack, Leeds; Arthur George Dalzell, Halifax; John Finn, Penrith; Frederick William Girven, Easington-lane; Joseph Jackson, Penrith; William Thomas Jelfs, Birmingham; Henry King, Millom; John William King, Blackburn; Augustus Henry Merryman, Castleford; Miss Lizzie Marguerite O'Kell, Bedford; Robert Claybourn Schofield, Keighley; George Scott, jun., Daisy Hill, *via* Chester-le-Street; George Siddali, Ossett Spa; and Alfred Wharfe, Keighley.

AN ARCHITECT TRIED FOR MANSLAUGHTER.

PROSECUTION ABANDONED.

At the Central Criminal Court yesterday (Thursday), before Mr. Justice Grantham, Charles James Chirley Pawley, architect and surveyor, of 2, Prince's Mansions, Victoria-street, S.W., was indicted for the manslaughter of William Clifford Morse, labourer, and six other builders' workmen in the employ of W. R. Rickard, who lost their lives by the collapse of the roof of Abbey Mansions, Orchard-street, Westminster, during the course of erection on April 21st. Mr. C. F. Gill, instructed by the Treasury, appeared for the prosecution, and prisoner was defended by Mr. Horace Ivory and Mr. Hugo Marshall, instructed by Messrs. Marshall and Marshall. On the case being called, Mr. Gill said the Treasury did not see their way, on a revision of the evidence, to proceed with the case. Mr. Justice Grantham expressed his concurrence in the decision arrived at, and the prisoner was accordingly acquitted, the jury returning a verdict of "Not Guilty."

The terminus of the Highland Railway at Kyle of Lochalsh has been lighted by acetylene gas, plant for the manufacture of which has been laid down by the British Acetylene Gas Generator Company (Limited), Kirkcaldy.

A new post-office in St. George's-place, Lord-street, Southport, was opened on Monday. The front is built of Storeton (Cheshire) stone, Aberdeen granite, and Accrington pressed bricks. The public office is a large room, with a counter running along three sides, but pierced in the centre so as to get to the public telephone room. A letter-box on the counter is a new feature. The sorting will be done in a large room in the rear, with a basement. Four rooms to the front over the public office are allotted to the surveyor, his assistants, clerks, and stores; and on the other side of the corridor are rooms for the postmaster and the chief clerk. The instrument rooms are on the second floor, and the caretaker's rooms on the third. Messrs. Wishart and Irving, Southport, are the chief contractors.

The Court of Common Council have under consideration a report from the City Lands Committee asking for authority to expend £2,500 in carrying out works at the entrance to Guildhall from Basinghall-street—viz., a new entrance gateway, asphalted paths and carriage-way, the forming of a dry area at the north end of the library; finishing the bay of the council-chamber by building a new window and buttresses, a new building on the site now occupied by the Chamberlain's old parlour, to contain offices; and a corridor connecting the library to the council chamber.

A special meeting of the Stockport Board of Guardians was held last week, to answer the inquiry of the Local Government Board as to the intentions of the guardians with reference to carrying out the plans for erecting a new workhouse sanctioned as long ago as January, 1897, this following upon a report by Mr. Dansey, poor-law inspector, that the present workhouse at Shaw Heath was overcrowded. It was stated that the tenders for the work were about £130,000, and that there was the land available for this extension, while the overcrowding was testified to by the master of the workhouse, who said the house was certified for 650, and he had accommodated over 900. After a lengthy discussion, it was decided to ascertain the cost of the workhouses at Gatshead, South Shields, Barton-on-Irwell, and Doncaster, and to seek an interview with the Local Government Board's architect and inspector.



FOUNTAIN AT MARKET DRAYTON.—MR. G. A. CRAIG, *Architect.*

#### FOUNTAIN, MARKET DRAYTON.

**T**HIS fountain has been erected by Messrs. Hawthorn, Bampfield Kettle, and R. Wycherley (the promoter and secretary, the chairman, and the vice-chairman, of the Market Drayton Water Company) to commemorate the 60th year of the reign of Queen Victoria. The drinking basins and the horse and dog-troughs are of red granite. The main parts of the structure, and the large basin, with the exception of the moulding at level of drinking basins, and the three-quarter detached shafts clustered round the octagonal pier supporting the basin, are of yellowish Grinshill stone. The other parts are of red stone from the Annan quarries, Dumfries. Let into three sides of the base of the octagonal pier are carved marble panels, that in front being a reproduction of the Jubilee medal, and the subjects of the others, "Rebecca at the Well"

and "Moses Striking the Rock." An inscription panel is at the back. The fountain was unveiled on Easter Monday, April 13, by Mr. H. R. Corbet, M.F.H., the lord of the manor. The work has been carried out by Mr. Henry Harding, architectural carver (of Nantwich, Cheshire), who is personally responsible for the whole of the carving. The lamp, of wrought iron and copper, is by Messrs. Brawn and Co., of Birmingham. The design is by Mr. George A. Craig, architect, of Market Drayton.

The directors of the Smelting Corporation, Limited, whose present headquarters and works are at Swansea, have decided to concentrate all the works of the company at Ellesmere Port, on the banks of the Manchester Ship Canal. The outlay will exceed £100,000, and not fewer than 700 hands will be employed at the works.

The new laboratories at University College, Liverpool, which have been erected and equipped by the Rev. S. A. Thompson Yates, for study and research in physiology and pathology, at a cost of over £25,000, will be formally opened on Oct. 8. Lord Lister, president of the Royal Society, will perform the opening ceremony.

Two of the pontoons intended for the passenger landing-stage on the Barry Island Railway extension have been delivered at Barry Dock from the works of Messrs. Lysaght and Sons, Bristol. These pontoons are 90ft. in length, and 24ft. beam, and 10ft. in depth. Another pontoon of like dimensions, intended for the same landing-stage, has been launched at the builder's yard, and the small pontoon is also on the blocks at Messrs. Lysaght's works. The sliding caisson at the entrance to the No. 2 dock at Barry will be completed by the builders, Messrs. Stephenson and Co., in the course of three or four weeks, but the new dock will not be ready for opening for at least another three months.





TOMB AT BURTON-LAZARS LEICESTERSHIRE      MURAL MONUMENT NEWBOLD WARWICKSHIRE  
NATIONAL BOOK PRIZE AWARDED A.E. MARTIN













STUDIES OF ANIMAL LIFE TREATED FOR DESIGN BY JOHN J. BROWNSWORD

NATIONAL SILVER MEDAL AWARDED







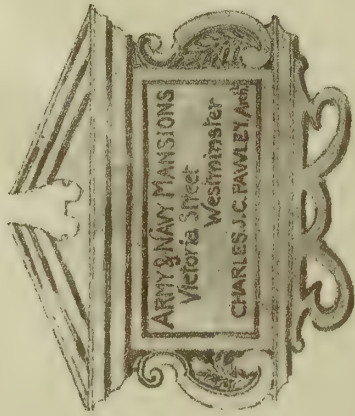

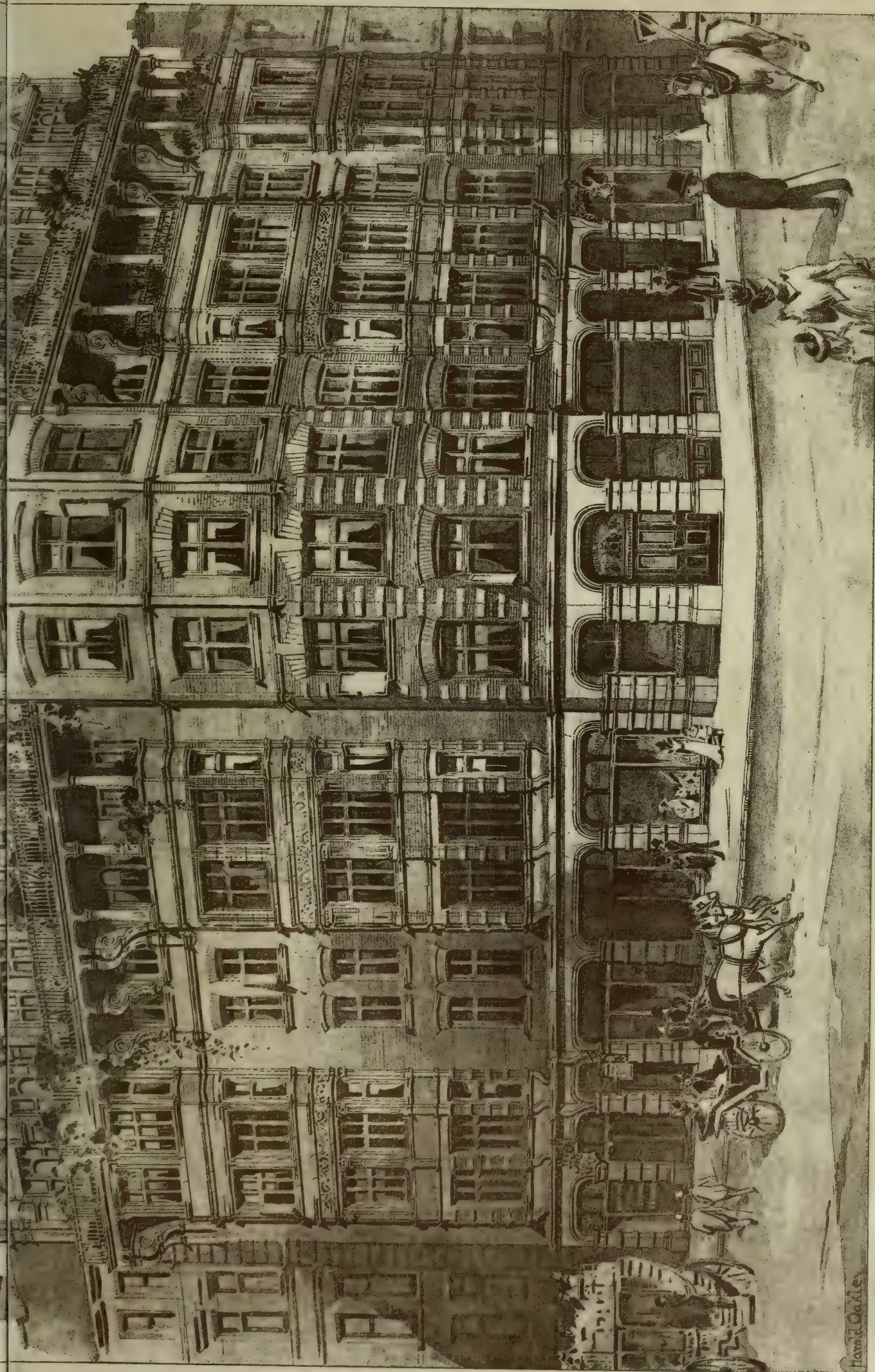
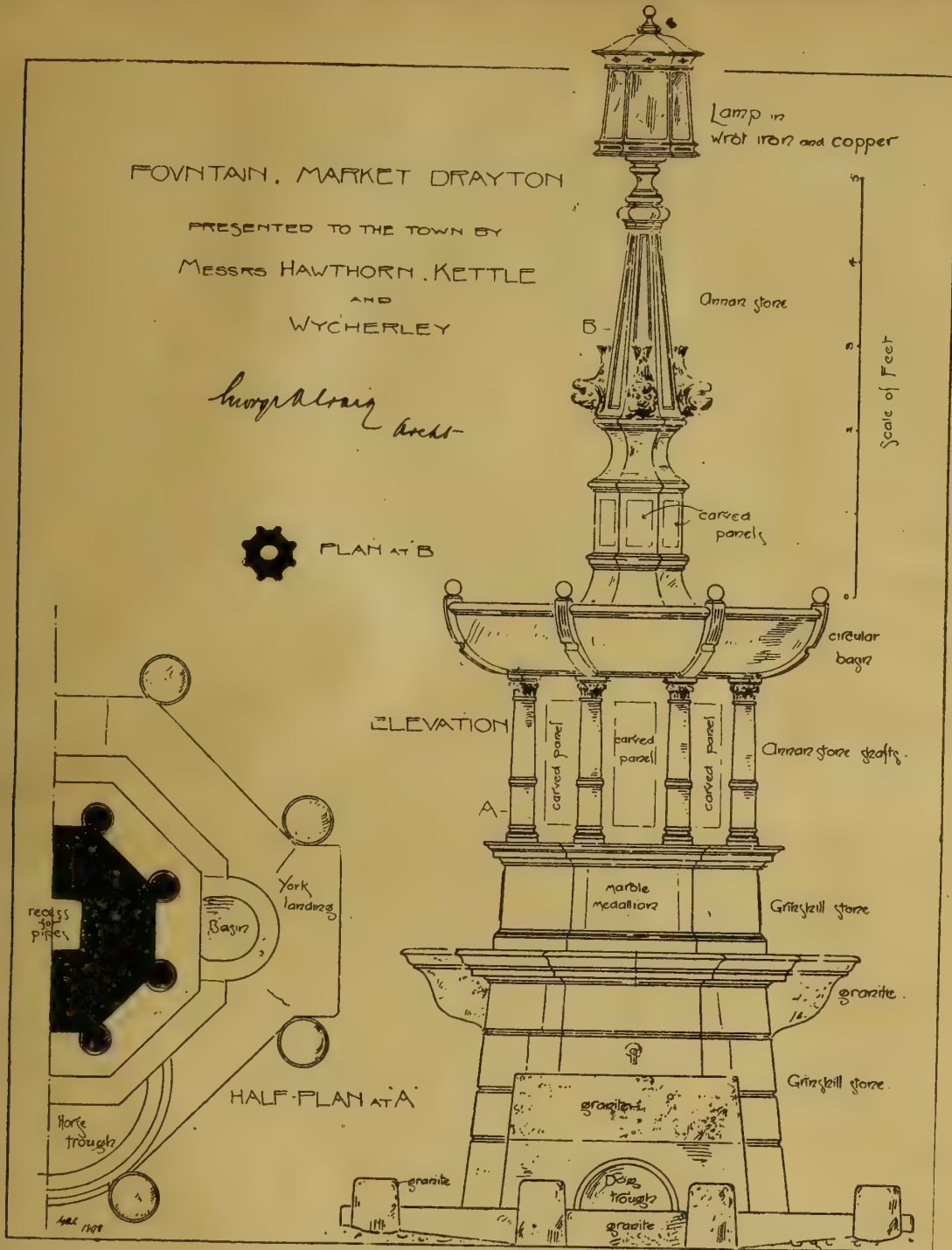

Photo-Tint. by James Akerman. Queen's Square, London W.

Harold Oakley





**CHIPS.**

The sanction of the Local Government Board has been obtained to the borrowing, by the Burnley Corporation, of £19,000 for works of sewerage and sewage disposal; £8,000 will be expended on sewage treatment and the rest on main sewerage.

In commemoration of the jubilee of the dedication of Holy Trinity Church, Hartshill, near Nuneaton, a new pulpit in pitch-pine, the work of Messrs. Pratt and Sons, of Covent Garden, W.C., has been erected, and the internal walls of the apsidal chancel have been decorated in colour and gold.

The vestry of Lee, S.E., have decided to purchase the ten acres of land surrounding the Manor House, together with an additional three-quarters of an acre from Lord Northbrook, for £9,600, as a recreation ground. Lord Northbrook has offered to contribute £1,300 towards the purchase, leaving £8,300 to be provided by the public authorities. The London County Council will, it is expected, contribute half of this amount.

The parish church new day-schools at Radcliffe, Lancs, will be opened by Archdeacon Wilson, of Rochdale, on July 5. The new schools, the foundation-stones of which were laid by Colonel Le Gendre Starkie last August, have been designed to accommodate 400 children. There are playgrounds at the back and front of the schools. The cost of the premises is £3,200. The architect is Mr. T. Bell, of Burnley.

A theatre and opera-house is about to be erected at Taunton. The drawings and plans for the building are being prepared by Messrs. Drake and Pizey, architects, Baldwin-street, Bristol.

Messrs. Gates and Thomas, contractors, Dawen, have commenced excavations in connection with the curved bridge which they have contracted to construct over the L. and N.W. Railway, near the level crossing at Sandycroft, Cheshire. The work will be supervised by Mr. Ross, agent to Messrs. Gates and Thomas, and Mr. C. Graves officiates as foreman. The work will be about 12 months in construction.

The town council and Burns club of Leith have agreed that the statue to Robert Burns shall be erected at the junction of Bernard and Constitution-streets, in that town.

The bridge carrying the South-Eastern Railway over Alaska-street (the first bridge past Waterloo Junction signal-box towards Charing Cross) is now being reconstructed, and all trains have to slow down to five miles an hour when passing over the bridge.

The Helensburgh Police Commissioners have offered to purchase the local gas undertaking at a total sum as finally adjusted of £31,116. The offer is subject to the consent of the shareholders being got and the Gas Supply (Scotland) Act adopted. Failing the commissioners' acceptance of these terms, the whole question of purchase to be submitted to arbitration.

The American School of Classical Studies at Rome will be for the next year under the charge of Professor Peck, of Yale, Professor Norton taking the chair of archaeology, and Professor Merrill that of Latin literature.

The South Hornsey Urban District Council have taken a poll of the ratepayers on the adoption of the Public Libraries Act; 2,430 papers were sent out. Only 970 papers were returned, 579 being for and 391 against the adoption.

A drinking fountain is about to be erected on Richmond Hill, as a memorial to the Duchess of Teck.

The Rev. T. H. Le Boeuf, the rector of Croyland, states that Messrs. John Thompson and Son, of Peterborough, recommenced work on the 1st inst. at the north wall of Croyland Abbey. He appeals for help towards raising the £1,380, which the work of underpinning the whole north aisle and the rebuilding the bay next the tower will cost.

The population of Carnforth has increased to over 3,000, owing to the fact that in recent years Carnforth has become an important railway centre and possesses large ironworks. The parish church, with only accommodation for 300, has become too small for the congregation, and plans have been prepared to extend the west end and provide additional accommodation, at a cost of £3,000. It has also been decided to build a new parsonage, at a cost of £1,200.

## TO CORRESPONDENTS.

[We do not hold ourselves responsible for the opinions of our correspondents. All communications should be drawn up as briefly as possible, as there are many claimants upon the space allotted to correspondents.]

It is particularly requested that all drawings and all communications respecting illustrations or literary matter should be addressed to the EDITOR of the BUILDING NEWS, 382, Strand, W.C., and not to members of the staff by name. Delay is not unfrequently otherwise caused. All drawings and other communications are sent at contributors' risks, and the Editor will not undertake to pay for, or be liable for, unsought contributions.

Cheques and Post-office Orders to be made payable to THE STRAND NEWSPAPER COMPANY, LIMITED.

## TERMS OF SUBSCRIPTION.

One Pound per annum (post free) to any part of the United Kingdom; for Canada, Nova Scotia, and the United States, £1 6s. 0d. (or 6dols. 30c. gold). To France or Belgium, £1 6s. 0d. (or 33fr. 30c.). To India, £1 6s. 0d. To any of the Australian Colonies or New Zealand, to the Cape, the West Indies, or Natal, £1 6s. 0d.

## ADVERTISEMENT CHARGES.

The charge for Competition and Contract Advertisements, Public Companies, and all official advertisements is 1s. per line of Eight words, the first line counting as two, the minimum charge being 5s. for four lines.

The charge for Auctions, Land Sales, and Miscellaneous and Trade Advertisements (except Situation advertisements) is 6d. per line of Eight words (the first line counting as two), the minimum charge being 4s. 6d. for 40 words. Special terms for series of more than six insertions can be ascertained on application to the Publisher.

Front-page Advertisements 2s. per line, and Paragraph Advertisements 1s. per line. No Front-page or Paragraph Advertisement inserted for less than 5s.

Advertisements for the current week must reach the office not later than 3 p.m. on Thursday. Front-page Advertisements and alterations in serial advertisements must reach the office by Tuesday morning to secure insertion.

## SITUATIONS.

The charge for advertisements for "Situations Vacant" or "Situations Wanted" is ONE SHILLING FOR TWENTY-FOUR WORDS, and Sixpence for every eight words after. All Situation Advertisements must be prepaid.

## NOTICE.

Bound copies of Vol. LXXIII. are now ready, and should be ordered early (price Twelve Shillings each), as only a limited number are done up. A few bound volumes of Vols. XXXIX., XL., XLI., XLVI., XLIX., LI., LIII., LVIII., LIX., LXI., LXII., LXIII., LXIV., LXV., LXVI., LXVII., LXVIII., LXIX., LXX., LXXI., LXXII. may still be had, price Twelve Shillings; all the other bound volumes are out of print. Most of the back numbers of former volumes are, however, to be had singly. Subscribers requiring any back numbers to complete volume just ended should order at once, as many of them soon run out of print.

RECEIVED.—G. C.—A. T. T.—A. T. Co.—F. D.—C. M.—D.—W. H. T.—T. D. B.—C. I. R.

## Intercommunication.

## QUESTIONS.

[1975.]—**Malleable Cast Iron.**—Wrought iron is much quicker corroded by rust than is ordinary cast iron. Will some reader kindly give me the benefit of his experience as to malleable cast iron? Is it, as to rusting, comparable with wrought iron or ordinary (non-malleable) cast iron, or does it hold an intermediate place.—A. H.

## REPLIES.

[1967.]—**Testing Cement.**—The best cement made is Portland cement, and there are several ways of testing it. It should be freshly ground, "cool," or it is liable to "blow" during setting. The weight is sometimes considered to be one test, a heavy cement being generally slow in setting compared to a light cement, though the weight may be due to adulteration, which, however, is now limited by an association of Portland cement manufacturers. There are special machines for testing the tensile strength, which should average about 350lb. per square inch after being set seven days under water. A thin pat carefully mixed with a minimum quantity of water, and placed on a piece of glass to set, should show no signs of cracking at the edges. A quantity of cement mixed and put in a glass bottle should not crack the bottle, for, if it does, it shows that the cement will swell excessively in setting, which property, however, is sometimes desirable in underpinning. This is a sketch of some methods of testing, which should be carried out by someone with a good experience before the value of the cement can be fully determined.—LOUIS ERWOLD.

[1968.]—**Soundproof Walls.**—The most effectual course for "M" to adopt will be to line the party-walls with some soft deadening material, such as silicate cotton. The simplest form of applying this to walls is in slabs of fibrous plaster padded on the inner side with the "wool," as per F. Jones and Co.'s patent.—GEO. BIRCHMORE, 119, Prince of Wales-road, Haverstock Hill, N.W.

[1968.]—**Sound-Proof Walls.**—The walls can be made sound-proof to a great extent by nailing battens on the walls and lathing and plastering on them.—LOUIS ERWOLD.

[1969.]—**Insurance.**—The difficulty to my mind is

to insure those who are only on for a short period, as I think the old hands would naturally consider it unfair that the migratory hands should have equal benefit with them, if the insurance was supported by the workmen themselves.—LOUIS ERWOLD.

[1970.]—**Fixing Stone.**—I think that cramping with metal cramps fixed with lead is the best; but the cramps are best made of copper, a cheap substitute being galvanised iron. Sulphur may be used instead of lead, and I never remember seeing any stones which had been affected by the sulphur.—LOUIS ERWOLD.

[1971.]—**Flare - Burnt Lime.**—Flare-burnt lime could be used in cases where it was desirable to have a white lime, such as might be used in gauged work, the lime being mixed with silver sand, or even marble dust.—LOUIS ERWOLD.

[1973.]—**Drain-Pipe.**—A 6in. pipe is amply sufficient for main drain to sewer. The fall from a to b is so small that it would be advisable to fix an automatic flushing tank at head of drainage system. The outlet ventilating shaft is taken from highest point in drain, while the inlet is situated at lowest point. Consult a book on the subject for further particulars.—LOUIS ERWOLD.

## CHIPS.

The new Cleveland Borough Lunatic Asylum at Middlebrough was formally opened on Wednesday in last week. It has been built at a cost, exclusive of site, of £20,000, from plans by, and under the supervision of, Mr. Alfred J. Wood, of 22, Surrey-street, Victoria Embankment, W.C.

St. Peter's Church, Wightman-road, Hornsey, which has been built from designs by Mr. Jas. Brooks and Son, Wellington-street, Strand, by William Parmenter, of Baintree, will be consecrated by the Bishop of London on Friday next, July 1st. It has been built of Monks Park stone, from the quarries of the Bath Stone Firms, Ltd., Bath.

Prince Christian visited Windsor on Tuesday to open a new ward, added to the Windsor and Eton Royal Infirmary in commemoration of the Queen's Diamond Jubilee.

The alcove at the end of the flower-garden, adjoining the conservatory, at Witley Court has just been occupied by a sculptured group in marble, life-size, representing Hagar and Ishmael. It is erected on a specially designed pedestal executed in Portland stone, with elaborately carved enrichments. The pedestal was designed by Mr. W. A. Forsyth, A.R.I.B.A., and executed by Mr. James Forsyth, of London.

On St. Alban's Day the Bishop of St. Alban's laid the foundation-stone of a new church dedicated to the first martyr of Britain at Westliff-on-Sea. The new district will be carved out of the ancient parish of Prittlewell, Essex. The nave, aisles, and chancel will be finished by Christmas. The architect is Mr. C. Nicholson.

The members of the Hawick Archaeological Society had their annual excursion on Tuesday. A company of over sixty, accompanied by the Rev. W. A. P. Johman, president, left Hawick in brakes, and, driving by way of Danholm and Ancrum Bridge, the company arrived at Monteviot, where, by permission of Lord Lothian, they walked through the grounds, and passing over the private bridge which spans the Teviot, the company proceeded to Jedburgh. The Abbey, Queen Mary's house, &c., were visited. The interior of Fernherst Castle, on the banks of the Jed, was inspected. It is at present being renovated by Lord Lothian. The return was made by way of Swinnie and Bonchester.

The Duke of Devonshire, president of Owens College, visited Manchester on Wednesday, accompanied by the Duchess of Devonshire, for the purpose of opening the new Christie Library at Owens College and laying the foundation-stone of the Whitworth Hall, another addition to the college buildings. The library, a stone building designed, like all the other college buildings, by Mr. A. Waterhouse, is the gift of Mr. R. C. Christie, formerly Chancellor of the diocese of Manchester. The expense of erecting the Whitworth Hall (some £50,000) Mr. Christie is bearing, as one of the residuary legatees of the estate of the late Sir Joseph Whitworth.

On Trinity Sunday, at St. Margaret's Church, Ickley, a service of dedication was held by the Bishop of Richmond of two windows, executed by Messrs. Powell, of Whitefriars Glass Works, at a cost of £1,150. The general idea is that the west and east windows correspond in conception, representing the Beginning and the End, the Old Creation and the New, the Earthly Paradise and the Heavenly, the First Adam and the Second, the Story of the Genesis contrasted with the Visions of the Apocalypse, the Past with the Future. Thus the figures of the west come mainly from the first book of the Bible, and the illustrative text from the Song of the Three Children; and those of the east almost entirely from the book of the Revelation. In each case the background of the picture is furnished by the Tree of Life (Gen. iii. and Rev. xxii.) A tablet has been supplied of opus sectile.

## PARLIAMENTARY NOTES.

**METROPOLIS MANAGEMENT ACTS AMENDMENT (BY-LAWS) BILL.**—Lord Monkswell moved, on Tuesday, the second reading of this Bill, which has for its object the amendment of the provisions of the Metropolis Management Acts with respect to by-laws. He explained that the Bill proposed to provide that the powers of the London County Council for making by-laws under section 202 of the Metropolis Management Act, 1855, should extend and apply to authorise the Council to make by-laws for the following purpose:—Requiring persons about to construct, reconstruct, or alter drains in connection with buildings, to deposit with the sanitary authority of the district such plans, sections, and particulars as might be necessary for the purpose of ascertaining whether such construction, reconstruction, or alteration was in accordance with the statutory provisions relative thereto, and with any by-laws made under the said section. It was perfectly clear, he said, that such a power was desirable, inasmuch as prevention was better than cure. He understood that the Government agreed with this view, but at present hardly made up its mind as to what authority should sanction these by-laws. Both the Home Office and Local Government Board had declared that they were not the authorities. He had not the slightest objection as to the body that might be selected to sanction the by-laws, but he wished the Bill to pass into law. The Marquess of Salisbury: In this chaotic state of things, which is new to me, I am very doubtful as to who is to move under this clause. Like most other people I have had my little difficulties with drains, and it appears to me, as I suppose it must do to everybody else who has had those difficulties, the object is to get the evil repaired with the shortest possible delay, and that any considerable delay is not only a matter of great inconvenience, but also a serious injury to health. Now, without in the least denying all the qualities which its admirers attribute to the London County Council, I imagine that it, with other departments, experiences the defect of not being able to conduct its work with great rapidity. Unless the departments, both Municipal, political, and Imperial, alter their nature very rapidly, I fear that means an interminable delay. I do not say that that is a reason for resisting the Second Reading of the Bill, but I think some provisions will be necessary for enabling more urgency to be declared, and for requiring the opinion of the County Council and of the Department to be given in a reasonable time. The Earl of Kimberley: It seems to me that a difficulty arises something in the nature of what the noble lord has said. Where there are to be draining operations on a large scale, very often I think it would be an advantage, and there would be no inconvenience from any such delay as might occur in submitting the plans; but, supposing the Bill passes, it does not only apply to large works, but, in point of fact, would require the deposit of plans with regard to the smallest alteration of drains. That could hardly have been intended. If, for the smallest alteration of drains, you are to be obliged to go and correspond with the County Council on the subject, it is pretty obvious that practically such a scheme could not be worked. Some care will be necessary to see that the Bill is not made applicable to such very small matters as might, in point of fact, produce both a nuisance and delay. The Bill was read a second time.

The New Jerusalem Church, Abbey-street, Accrington, was reopened on Saturday, after undergoing renovation and alterations at a cost of over £3,000.

At St. Mary's parish church, Whitby, on Monday, a newly-erected clock in the tower was dedicated, in commemoration of the Diamond Jubilee of the Queen, by the Rev. Marquis of Normandy. The clock has been made and supplied by Messrs. Potts and Sons, of Leeds and Newcastle.

Princess Christian opened, on Friday, the new school which has been erected by the governors of the Stepany and Bow Foundation. The building, which stands on the site of Nos. 31 and 33, Bow-road, forms a complete block, the external portion being faced with red bricks, with Portland stone dressing, while in the interior are 12 classrooms, laboratory, dining-room, and offices, planned to accommodate 300 girls. The contract price for the erection of the building was £13,000.

The members of the Oxford Architectural and Historical Society, with friends introduced by them, numbering together about 120, visited Cambridge on Thursday in last week. On arriving they were received at the Museum of Classical and General Archaeology by Professor Ridgeway, the president of the Cambridge Antiquarian Society, who gave a short address upon the general history of Cambridge, and afterwards, with the secretary of the same society, Mr. T. D. Atkinson, accompanied the party to nearly all the colleges, giving short descriptions of the buildings visited, together with brief references to their historical associations.

## LEGAL INTELLIGENCE.

**THE RESULT OF A STRIKE.**—William Ludgrove, of 47, Chaldon-road, Fulham Cross, brought an action against Messrs. Stephens, Bastow, and Co., builders, of Basil-street, Knightsbridge, to recover the sum of £5, which he alleged to be due to him. Mr. Mozley Stark was solicitor for the plaintiff, while Mr. F. J. Robinson defended. According to the opening statement of Mr. Stark, the claim was for one week's wages, and one week in lieu of notice. Plaintiff left because Mr. Stacey, the manager, wanted him to do some bricklayer's work. He objected, being employed as foreman. Answering Mr. Robinson, plaintiff said that at the time there was a dispute between some bricklayers and plasterers. The result of this was that the bricklayers struck work. Mr. Robinson: You belong to the Union, don't you? Yes. And you were in favour of the bricklayers? Naturally. And it was in consequence that a strike occurred? No. Were you not doing picketing? No, sir. Why did you leave? Because I was asked to do bricklayer's work. I was engaged as a foreman. Didn't Mr. Stacey tell you that you would have to go to work or leave? Yes, he told me to do so, but I refused. I took no part whatever in the strike. For the defence, Mr. Robinson contended that the plaintiff could not recover, as he refused to work. His Honour: I find for the defendants. I think that the plaintiff ought to have done the work.

**IN RE AETHERTON AND DOLMAN.**—The bankrupts were builders, carrying on business at Poplar. They failed in November last, and applied on the 15th inst. for their discharge. The assets have realised £1,823 11s. 7d., and it is expected that about £700 further will be received. Proofs amounting to £9,838 have been made against the joint estate. The Official Receiver reported that the assets were not sufficient for the payment of 10s. in the pound on the unsecured liabilities, and that the bankrupts had not kept proper books of account. His Honour suspended the order of discharge for two years.

**BURIAL AUTHORITIES AND PURCHASES FOR EXTENSIONS.**—In the Court of Appeal on Thursday, the 16th inst., before the Master of the Rolls and Lords Justices Chitty and Collins, judgment was given in an appeal, "Ward v. The Portsmouth Corporation." Mr. Justice Byrne held that under the Burial Acts, 1852 and 1853, a burial authority had no power to buy land intended to provide at a future date for interment without the previous sanction of the Secretary of State. The decision of the case turned on the meaning of the expression "provide and use" a burial ground, which by force of certain sections of those Acts a burial authority is prohibited from doing without the sanction of a Secretary of State. The short facts of the case were as follows:—The plaintiff, Mr. William Ward, being then the owner of certain land in the parish of Portsea, in August, 1889, agreed with the burial board for the parish of Portsmouth for the purchase of the land for £6,270, of which £100 was to be (and, in fact, was) paid at the time and the balance on completion of the purchase on June 24, 1896. Before the agreement was entered into, the consent of the Portsmouth vestry was obtained, as required by Section 26 of the Burial Act, 1852. In January, 1895, the Corporation of Portsmouth, as the urban sanitary authority, passed a resolution under Section 62 of the Local Government Act, 1894, in pursuance of which the corporation became the statutory successors of the burial board on June 11, 1896. The corporation intimated to the plaintiff, Mr. Ward, that it did not intend to complete the contract. The land had been agreed to be bought for the purpose of enlarging the then existing cemetery for the parish of Portsmouth, but the Home Secretary had refused to give to the Corporation the approval required by the Burial Act, 1853. The plaintiff contended that if this refusal did not justify the corporation in refusing to complete their contract to purchase, and brought the present action for specific performance of the contract, or, alternatively, for damages. Mr. Justice Byrne gave judgment for the defendant Corporation, but their Lordships now reversed his finding, allowed the appeal with costs, and granted damages in lieu of specific performance, directing an inquiry as to their amount.

**RESTRICTIVE COVENANTS NOT BINDING ON VENDORS.**—**HOLFORD V. URBAN DISTRICT COUNCIL OF ACORN.**—In the Chancery Division, on Saturday, Mr. Justice Stirling gave judgment in this action, which was brought to restrain the defendants from erecting upon certain plots of land belonging to them a fire-engine station or any buildings other than shops and dwelling-houses of a certain value in alleged breach of a condition of sale under which the plaintiffs had brought from the defendants an adjoining plot of land. The land in question, together with other land, was originally acquired by the defendants under their compulsory powers for the purpose of street improvements in their district. In 1894 they sold a portion of the land so acquired by action under conditions of sale, which provided that the respective purchasers of certain specified lots should in their respective conveyances enter

into covenants with the vendors to erect within two years from the day of sale upon each of the lots bought by them a shop and dwelling-house of not less value than £650. The plaintiff bought one of the plots at the sale and erected thereon a shop and dwelling-house in compliance with the condition. Certain of the plots were not sold, and the defendants had recently determined to erect upon the plots remaining in their possession a fire-engine station which was required for the purposes of their district, and had obtained the sanction of the Local Government Board to the issue of a loan for the purpose of providing the necessary funds. The plaintiff therefore brought this action, contending that the proposed erection of the fire-engine station would be a breach of the condition under which he had bought his property and by which the defendants were themselves bound. Mr. Jenkins, Q.C., and Mr. Tanner appeared for the plaintiff, and contended that he was entitled to restrain the defendants from dealing with the land in any way inconsistent with the condition. Mr. Butcher, Q.C., and Mr. MacSwiney, for the defendants, argued, first, that the covenant was affirmative in form, and there was no negative stipulation not to erect upon the land any buildings other than shops or dwelling-houses, and as no such negative stipulation could be implied the defendants could not be restrained by injunction. Secondly, they contended that even if the covenant could be enforced as between the respective purchasers, it was not binding as against the defendants, inasmuch as it would be beyond their powers to subject the land in their hands to a restrictive condition which would have the effect of preventing them dealing with it for the purposes of the requirements of their district. Mr. Justice Stirling gave judgment on Saturday, and came to the conclusion that, having regard to the authorities, no negative stipulation could be implied in the condition. That being so, the restrictive covenant could not be enforced against the defendants, and the action failed and must be dismissed, and (except as to a special direction on one point) with costs as between solicitor and client pursuant to the powers of the Public Authorities Protection Act, 1893.

## CHIPS.

On Saturday a special service was held in Tottenhall Church, Wolverhampton, for the purpose of dedicating three stained-glass windows. The designs of the windows were "The Flight into Egypt," "The Carpenter's Shop at Nazareth," and "The Presentation in the Temple," and the work was executed at the establishment of Mr. C. E. Kempe, London.

The new cottage hospital, Norbiton, is being warmed and ventilated by means of Shorland's patent Manchester grates, the same being supplied by Messrs. E. H. Shorland and Brother, of Manchester.

The foundation-stone of the new harbour works at Ostend was laid by the King of the Belgians on Sunday.

The Ashford Rural District Council have instructed Messrs. Bailey Denton, Son, and Lawford, of Westminster, to advise them as to an efficient system of water-supply for Willesborough, a populous suburb of Ashford, where the works of the South-Eastern Railway are situated.

The Marquis of Ripon, K.G., on Friday, visited Brighouse to perform the opening ceremony of a new town's Free Library and Museum. The institution occupies a mansion known as the Rhydings, standing in its own grounds off Halifax-road, the property being purchased for £3,600. The grounds have been laid out as a public park.

The Peruvian Consulate General in London calls the attention of manufacturers to the Permanent Exhibition of Manufactures and Machinery, now open in Lima, in the Machinery Hall of the Exhibition Palace, under the auspices of the Government of Peru, and under the management of the National Society of Industry. No charge is made for space, no duties on exhibits, and many privileges are accorded to exhibitors. Peru offers a splendid field for the extension of British trade. Full particulars may be had of Mr. E. Lembecke, Consul-General, 237, Winchester House, Old Broad-street, E.C.

The tender of Mr. Thomas Smith, Chilvers Coton, has been accepted for the erection of a new Baptist Church, at the corner of Willington-street and Manor Court-road, Nuneaton. Five tenders were submitted, and the lowest was that of Mr. Smith, £4,060. Building operations will commence shortly. The architect is Mr. John Wills, F.S.Sc., Victoria Chambers, Derby. The style adopted is Early Gothic. The church will provide accommodation for 671 adults, and the schools will accommodate 466 young persons. The assembly-room will seat 350 to 400 people. The walls will be of brick, with white stone dressings, and the seats and rostrum will be of pitch-pine. The heating will be by hot water, low-pressure system.

## Our Office Table.

WE regret to hear that Mr. Arthur Cates, for more than half a century past the surveyor to the Commissioners of Woods and Forests (or, in other words, to the Crown), and who is also president of the Appellate Committee under the London Building Act, is about to retire owing to failing health. No one has had a more extensive connection with the improvement of London than Mr. Cates. The Commissioners own a vast amount of property in the Metropolis, and during Mr. Cates's period of office a great portion of it has been rebuilt. Battersea Park, Whitehall-court, and many other extensive schemes have been carried out under Mr. Cates's direction. Mr. Cates's offices occupy part of the site to be utilised for the new War Office buildings which are shortly to be commenced. These will cover the whole of the island between Whitehall-place, Whitehall-court, and Whitehall. Mr. Cates is to be succeeded by his nephew, Mr. Green, a well-known architect. Mr. Cates has done an immense amount of unrequited service to the architectural profession, notably in connection with the examination movement, into which he has thrown his heart and soul since 1855. He joined the Board of Examiners in 1877, and acted as its chairman from 1882—when the examination became compulsory on those seeking to become Associates of the Institute—until January of last year, when he retired.

MR. F. C. PENROSE, F.R.S., F.R.I.B.A., who last week received the honorary degree of LL.D. from Cambridge University, was further honoured on Wednesday by the University of Oxford, which conferred upon him the honorary degree of Doctor of Civil Laws. In introducing Mr. Penrose, reference was made by Dr. Goudy, Regius Professor of Civil Law, to the renown which he had acquired at Cambridge as an oarsman. On leaving the University, he began the investigation, as an architect, of ancient Classical monuments, and introduced a new method for determining the age of ancient temples from their orientation. To no one more than to him was the present success and popularity of archaeological studies to be attributed.

A CONFERENCE of Peers, members of the House of Commons, and representatives of associations interested, was held in Committee-room 13 of the House of Commons at 5 p.m. yesterday (Thursday) to consider the desirability of making some permanent arrangement for concerted action between members of Parliament in both houses on questions relating to (a) the protection of rural scenes and landscape and town prospects from such disfigurement or impairment as is not justified by considerations of public utility; (b) the provision and maintenance of commons, open spaces, public parks, and gardens; (c) the preservation of buildings and places which are of peculiar interest by age, beauty, or association, whether historical or literary; (d) the conservation of wild animals and plants; and generally for asserting the importance on broad grounds of public policy of maintaining beauty, simplicity, dignity, and interest in the aspect of out-of-doors Britain. The Right Hon. James Bryce, M.P., and Mr. Boulnois, M.P., were among the principal speakers. With a view to assisting from outside, and of co-ordinating the various agencies now in existence for the promotion of the ends indicated, it was decided that the Commons Preservation Society, the Metropolitan Public Gardens Association, the Kyrle Society, the National Trust, the Selbourne Society, the Society for the Protection of Ancient Buildings, the Society of Antiquaries, and the Society for Checking the Abuses of Public Advertising, be asked to appoint each two members, who shall form a Joint Standing Committee.

THE action of the scientific men who protested against the Government proposal in connection with the building scheme at South Kensington to find room for the science collections alongside the art sections on the east of the Exhibition-road has led to a reconsideration of the question on the part of H.M. Office of Works, and it is now probable that some modification of the scheme will be made by the authorities. A suggestion finds favour that, while the whole new front of the South Kensington Museum should be devoted to the purposes of art, part of the east wing to be erected might serve as an extension of the Royal College of Science, which cannot well be moved from its present site to a position across the

Exhibition-road, where the rest of the scientific departments are housed.

THE urban district council of Walthamstow have accepted an offer from the Lloyd family to present to them the ornamental grounds surrounding the house known as the Winns, in Forest-road, consisting of about 9½ acres, for use as a recreation ground, provided the council will purchase from the executors of the late Mr. Lloyd the adjoining pieces of land, containing 9½ acres, to be used as public playing-fields in connection with the recreation ground, at a valuation to be made by an independent surveyor. The president of the Surveyors' Institution, who was invited to appoint a valuer for the playing-fields, has nominated Mr. Alfred Savill, of New Broad-street. The Winns is a manor house standing in its own grounds, and was built in 1760. It was the birthplace of the late William Morris, art decorator, socialist, and poet, and for many years it was occupied by the late Mr. Edward Lloyd, the last tenant, who followed Mrs. Morris, but has been empty for thirteen years past.

An important addition to the accommodation provided for scholars and students at the British Museum has lately been made. This is a new room specially set apart for persons studying or engaged in researches in Oriental literature as distinct from the general reading-room. The room is an annexe of the department of Oriental printed books and manuscripts, and accommodates 24 students. The regulations for admission are those of the general reading-room. The department has lately issued the largest and fullest catalogue of Japanese books ever printed in Europe, consisting of upwards of 5,000 separate Japanese works, representing the museum collection, which has been brought together during many years and under various circumstances.

THE second annual exhibition connected with the building and decorative trades was opened at St. James's Hall, Manchester, on Monday. An effort has been made on this occasion to bring together the most recent improvements, chiefly in sanitary appliances, in order to show the constant progress which is being made. There are more than one hundred stands, some of these being devoted to terracotta, majolica, and art metal ware, mosaic flooring, woodwork, stained-glass, &c. There are the usual entertainments with which visitors to these exhibitions have become familiar, during the week, the chief being a series of performances by the string band of the Royal Artillery from Woolwich, which was present yesterday. At the opening, on Monday, Mr. Edward Salomons, architect, presiding, Mr. R. J. Bennett, president of the Manchester Society of Architects, said he understood that last year the exhibition was visited by 60,000 people, and he hoped that this year the number would be doubled. Speaking of the educational benefits of such exhibitions, he referred to sanitary appliances, in which, he said, they had made greater progress than in any other department of the building trade. Corporations and local authorities had become extremely alive to their responsibilities, insisting upon more wholesome conditions of life, and doing their best not only to provide a remedy for, but a prevention of, evils which had existed in the past. Manchester was one of the centres which had been placed highest in the mortality table, but in recent years the figures had been reduced eight per thousand, and although this was satisfactory, they were still five per thousand ahead of London, with its enormous aggregation of human life. No doubt by taking full advantage of the latest improvements in sanitary science they could get on a level, if not advance upon, London.

Mr. Frank Dethridge, vestry clerk of Paddington, on Monday received from the Chancellor of the London Consistory Court a faculty enabling the local vestry to erect a town-hall on the ground covered by, and at the rear of, the present vestry-hall, Harrow-road—a building found wholly inadequate to present requirements.

The Clarendon Temperance Hotel in Clayton-street, Newcastle-on-Tyne, was opened on Friday. The building occupies the site upon which stood the John Knox Presbyterian Church—now migrated to Elswick-road. Its main front is into Clayton-street, its two sides face Berwick-street on the one hand, and Pink-lane on the other. The hotel occupies the greater part of the edifice, and a portion is devoted to business premises, with shops and offices. The building was designed by Messrs. Oliver and Leeson, and built by Messrs. J. and W. Lowery, all of Newcastle.

### MEETINGS FOR THE ENSUING WEEK.

MONDAY.—Royal Institute of British Architects. Special Business Meeting to consider the Revised Schedule of Professional Charges. 8 p.m.

THURSDAY.—Dundee Institute of Architecture. Annual Meeting. 2.30 p.m.

### THE ARCHITECTURAL ASSOCIATION.

JULY 2nd, VISIT to Hever Castle, Kent. P.O. for 2s. 9d. to be sent to Mr. A. S. Flower, 7, Gordon-place, W.C., on or before JUNE 29th. Meet below clock at Victoria Station at 1.15 for the 1.30 train. Return train leaves Hever at 6.30.

E. HOWLEY SIM } Hon. Secs.  
G. B. CARVILL }

### CHIPS.

The very interesting house in Westbourne-grove, for many years occupied by Prince Lucien Bonaparte, is now being converted into residential flats, from the designs of Mr. W. I. Chambers, architect, Savoy House, W.C.

The school board for St. Mary Extra, near Southampton, have adopted plans by Messrs. Mitchell, Son, and Gutteridge, of the latter town, for new schools in Ludlow-road.

The Salford Board of Guardians have resolved, subject to the consent of the Local Government Board, to purchase Twiss Green House and land situate at Kenyon Junction, containing about 40 acres, for £4,500, as a site for cottage homes for poor children.

The work of building additional classrooms and cloak-rooms at St. Anne's schools, Edge-lane, Royton, Lancs, has commenced. The contract has been let to Mr. Whittaker, of Oldham, at about £500.

The plans of Mr. C. A. Sharp, of 59, Fenchurch-street, have been accepted by the managers of the Kensington and Chelsea School District for the erection of a drill-hall and gymnasium.

Mr. W. G. Willcocks, Local Government Board Inspector, held an inquiry at Rugby on Friday, with reference to the application of the urban district council to borrow £2,650 for the purchase of land for sewage disposal purposes, £1,926 for a new fire-engine station, £770 for an improved outfall sewer, and £2,500 towards the cost of erecting new public offices on the site of the Shoulder of Mutton Inn, in the High-street, recently bequeathed to the council.

The town clerk of Bradford has received from Lord Masham a cheque for the £40,000 which his lordship promised for the erection of a Cartwright Memorial and Art Gallery in Manningham Park.

The members of the Newcastle Society of Antiquaries will hold their first country meeting of the season on Monday, July 4, at Raby and Staindrop. Raby Castle, the ancient seat of the Nevills, will, by permission of Lord Barnard, be visited, and will be described by the Vicar of Witton-le-Wear, the Rev. J. F. Hodgson, who will also describe Staindrop Church, which will subsequently be inspected.

The foundation-stones of a new Conservative club now in course of erection at the corner of New Bridge-street, Nuneaton, were laid on Saturday by Mr. F. A. Newdigate, M.P. We illustrated the building in our issue of the 3rd inst. The contractor is Mr. T. Smith, of Chilvers Coton, and the architect is Mr. Charles William Smith, M.S.A., Grantham, whose plans were selected in competition.

Mr. F. T. Beck, architect, of Wolverhampton, has been appointed surveyor for the archdeaconry of Stafford, in succession to the late Mr. J. R. Veall, of the same town.

Last week the opening took place of the new waterworks for Machynlleth, in the Esgaireira Valley, which is situated about 4½ miles from Machynlleth, and impounds the water from two streams flowing down the Cwmresger Valleys. The area of the reservoir is about 2½ acres, and it contains, when full, about 7,000,000 gallons. Its greatest depth is 21ft., and it will afford 86 days' supply to the town of Machynlleth at a time when the brooks are dry. The works have cost the urban district council over £6,000. Mr. Kirby was the engineer, Mr. Phoenix the contractor, and Mr. C. Smith the clerk of works.

The monument to Pasteur to be erected before the Pantheon, Paris, will show him putting Death to flight, and a mother with her child thanking him, while Fame crowns him with laurel. The international subscription for the monument is now nearly £13,000.

The widening of the junction of Arwenack and Church-street, Falmouth, by the setting back of a portion of the church boundary wall, is now being effected by Messrs. Corder and Barnicoat, for the churchwardens and the corporation.

The memorial-stone of the new church of St. Luke, West Hampstead, was laid on Saturday. The church is being built from plans by Mr. Basil Champneys, B.A., at a cost of about £11,500.

## Trade News.

### WAGES MOVEMENTS.

ASHTON-UNDER-LYME.—The dispute in the Lancashire and Cheshire building trade has extended to the Ashton-under-Lyme district, and on Saturday the federated employers locked out 50 per cent. of the stonemasons. The men ask for an advance of 1d. per hour, and certain changes in rules governing their employment. On Saturday the Bolton operative plasterers struck work for an advance in wages of 1d. per hour, and a reduction of two and a half hours per week. The masters offer to grant the increase in pay, but refuse the reduction of hours.

BERWICK-ON-TWEED.—The masters have granted an advance of 1d. per hour to the plasterers, who last week struck for a rise of wages from 7d. to 8d. per hour.

BLACKPOOL.—Another dispute commenced between the master builders and bricklayers on Thursday in last week, when the Bricklayers' Union called out all the men in the town. The union first stopped all members working who were not in receipt of the extra penny advance which was demanded some weeks ago. At that time the rate of a bricksetter's wages was 9d. per hour, and they then followed in the footsteps of the plasterers, who had succeeded in getting an increase from 9d. to 10d. The masters, in a few instances, had no alternative but to grant the request, owing to important contract work in hand, and the fact that proprietors were pressing for a completion of the work; but others refused the advance.

BOLTON.—The six months' notice given by the Bolton operative plasterers expired on Saturday, and as the employers and the operatives had been unable to come to an agreement on the points in dispute, the men, to the number of 75, left work on Saturday. The notice asked for an increase of wages from 9d. to 10d. per hour, making an increase of 2s. 3d. on the week, and a reduction of working hours in summer from 52 to 49½ hours a week, which would mean taking off half an hour every morning except Monday, which is a shorter working day. The masters contended that the notice was illegal, as it ought to expire, according to the working rule, either in July or August. They offered a 1d. per hour advance on condition that the notice was extended to July 18, with a slight alteration in the hours. The men rejected these proposals, the decision being communicated to the masters on Friday evening. The labourers have accepted ½d. per hour advance, and have had working rules signed between themselves and the employers, and will remain at work. With their aid, the masters believe they will be in a position, with their apprentices, to cope with most of their work.

LIVERPOOL.—Unless a settlement is soon arrived at between the operative masons and their employers in Manchester, Aston, Bury, Chorley, Preston, and Lancaster, the dispute will have a serious effect upon Liverpool, where the masters intend to take a stand beside the other employers. In Liverpool the federated employers have posted the following circular:—"This is to give notice that unless the dispute now in progress in the towns (those already mentioned) affiliated to the federation is settled on or before Saturday, July 9, the masons employed in the work will be locked-out. By order of the federation." The dispute has arisen because, it is alleged, the masters are bringing stone worked at quarries in districts where the men are underpaid.

SUNDERLAND.—The bricklayers' labourers at Sunderland have rejected the offer of the Master Builder's Association of a farthing per hour advance in wages.

The municipality of Calloa has decided to construct water and drainage works at an estimated cost of £60,000.

A new chapel for the Free Methodists has been opened in Parks Hill, Bury, Lancs. It provides nearly 500 sittings, and has cost over £2,500.

The Lord Mayor visited Dartford on Saturday, and laid the foundation-stone of a new chapel, which forms part of extensive additions to the City of London Lunatic Asylum at Stone. The chapel will be Early Decorated in style, and will accommodate 300 persons.

The London United Tramways Bill, which provides for the erection of electric tramways in Acton, Ealing, Brentford, and Isleworth, of about six miles in length, to be worked on the "trolley" system of overhead wires, was considered on Friday, Monday, and Tuesday by a Select Committee of the House of Commons. They decided that the preamble of the Bill with regard to tramways Nos. 6 and 7, the Boston-road, and the New Bridge to Hounslow sections—was proved, but were of opinion that the preamble was not proved with regard to tramway No. 8—Ealing.



LIST OF COMPETITIONS OPEN.

Rotherham—Additions to Thornhill Board Schools.....	No first, £15, £10	W. H. Cordridge, Clerk, School Board Offices, Rotherham	June 30
Penshurst—Three-Bedroomed Cottages (£180 limit each)		J. Escombe, Secretary, Penshurst, Tonbridge	" 30
Baldon—Sewage Precipitation Scheme	No premium; commission	H. R. Huggins, U.D.C. Clerk, Baldon, Yorks	" 30
Bridlington Quay—Orphanage and Convalescent Home, St. John's-avenue (cost about £1,500)	£25, £10	George Abbott, Secretary, 222, Solly-street, Sheffield	" 30
Formby—Sewerage of a Portion of the Township	£100, £50, £25	J. H. Havelock Sutton, Surveyor, Piercefield-road, Formby	July 1
Widnes—Laying-Out Park	£36 15s., £10 10s., £5 5s.	H. S. Oppenheim, Town Clerk, Widnes	" 1
Linsdale—Sewage Disposal and Water Supply		R. I. Platten, Clerk, Linslade, Leighton Buzzard	" 1
Warrington—Police Station, Court House, &c.	£100, £50, £25	J. Lyon Whittle, Clerk, Town Hall, Warrington	" 2
Beverly—Extension of East Riding County Council Offices	£30 (merged), £20, £10	J. Bickersteth, Clerk, County Hall, Beverley	" 16
West Hartlepool—Refuse Destructor, Burn-road		J. Bickersteth, Borough Engineer, Municipal Bldings, W. Hartlepool	" 27
Wivenhoe—Water-Supply and Drainage Schemes		J. W. Denton, Clerk, East Stockwell-street, Colchester	" 27
Glasgow—Exhibition Buildings (£60,000 limit)	£210 (merged), £156 10s., £105	C. W. Denton, Clerk, East Stockwell-street, Colchester	" 27
Pendlebury—Three Chapels, Offices, Lodge, Entrance Gates, and Boundary Wall, at proposed Cemetery	£50 (and 5 per cent. com.), £30, £20	H. A. Hedley, Secretary, 141, Buchanan-street, Glasgow	Aug. 15
Stockholm—City Railway Stations and Junctions	£656, £438, £219	Samuel Brown, Town Clerk, Town Hall, Salford	" 16
Liverpool—New Buildings for Royal Institution	50gns., 20gns.	Consulate General, 27, Great Winchester-street, E.C.	" 31
Glasgow—Sketch Models of Stone Figures for Fine Art Galleries	No premium	Harold Waterhouse, Hon. Sec., 3, Cook-street, Liverpool	" 31
Godalming—Football Stand (150 seats—£150 limit)	£3 3s.	J. D. Marwick, Town Clerk, City Chambers, Glasgow	"
		Secretary, Recreation Club, Godalming	"

LIST OF TENDERS OPEN.

BUILDINGS.

Kiskeeam—Creamery Auxiliary	Co-operative Wholesale Society	J. Turnbull, Manager, 20, John-street, Cork	June 25
Flookburgh—Three Cottages	Cottage Co.	W. R. Nash, Clerk	" 25
Cwmaman—Thirty-four Cottages	Corporation	T. Roderick, Architect, Clifton-street, Aberdare	" 25
Derbyshire—Additions to Abbotsholm School	Wm. Green and Sons	Wm. Sugden and Son, F.R.I.B.A., Leek and Hanley	" 25
York—Electric Light Station	Samuel Carne, Halwyn	A. Creer, City Engineer, Guildhall, York	" 25
Cleator Moor—Masonic Lodge	Guardians	E. Jackson, C.E., Tangier Buildings, Whitehaven	" 25
Rushden—Additions to Factory, Queen-street	Co-operative Society, Ltd.	Mosley and Anderson, Architects, Northampton	" 25
Peterhead—Police Buildings	Health Committee	William Henderson and Sons, Architects, Aberdeen	" 25
Paul—Two Cottages	Corporation	Henry Maddern, F.R.I.B.A., 1, Parade-passag, Penzance	" 25
New Malden—Two Pairs Semi-Detached Houses	Jas. Daly	R. Allesbrooke Hinds, Architect, 36A, Hill-road, Wimbledon	" 25
Merthyr Tydfil—Master's House at Workhouse	Corporation	Frank T. James, Clerk, 134, High-street, Merthyr Tydfil	" 25
Abbotsholme—Additions to School	Guardians	Wm. Sugden and Son, F.R.I.B.A., Leek	" 25
Barrow—Bakery, Thwaite-street	Co-operative Society, Ltd.	Jas. Clarkson, Secretary, Abbey-road, Barrow	" 25
Nelson—Refuse Destructor	Health Committee	Jas. Prescott, Town Clerk, Town Hall, Nelson	" 25
Kirkpatrick-Fleming—Dwelling-House	Corporation	R. M. McDonald, Writer, Commercial Bank Buildings, Annan	" 25
Barnstaple—Repairing Guildhall and Council Chamber	Jas. Daly	W. C. Oliver, Architect, Bridge End, Barnstaple	" 25
Consett—Repairs to Properties	Corporation	John Doherty, Architect, Consett	" 25
New Malden—Two Pairs Semi-Detached Houses	Guardians	R. Allesbrooke Hinds, Architect, 36A, Hill-road, Wimbledon	" 25
Leeds—Dead Meat Market	Co-operative Society, Ltd.	J. Harrison, Town Clerk, Leeds	" 25
Shillelagh—Additions to Workhouse Infirmary	Health Committee	J. Hopkins, Clerk, Shillelagh	" 25
Alveys—New Farmhouse	Corporation	Reid and Wittet, Architects, Elgin	" 25
Mallow—Cottage at Woodpark	Guardians	Maurice Regan, Poor Law Office, Mallow	" 25
Hanwell, W.—Cottage Hospital	Diamond Jubilee Committee	W. L. Williams, Hon. Sec., District Council Offices, Hanwell, W.	" 25
Maesteg—Rock Hotel, Tywisch	Guardians	J. C. Rees, Architect, Neath	" 25
Merthyr Tydfil—Rebuilding Workhouse Dining Hall	Monmouthshire County Council	Frank T. James, Clerk, 134, High-street, Merthyr Tydfil	" 25
Aberbeeg—Police Station	Guardians	Wm. Tanner, County Surveyor, Newport	" 27
Knutsford—Workhouse Chapel and Vagrant Wards	Monmouthshire County Council	G. Lee, Clerk, Union Offices, Knutsford	" 27
Leicester—Isolation Hospital	Mullen and Turner	Blackwell and Thomson, Architects, Halford-street, Leicester	" 27
Pudsey—Conservative Club	School Board	Holtom and Fox, Architects, Westgate, Dewsbury	" 27
Lower Thames-street, E.C.—Repairing Warehouses, Wool Quay	Parish Council	C. Thompson, Architect, 203, Graham-road, Hackney	" 27
Ebbw Vale—Pety Sessional Court	Chepstow Oddfellows Society	Wm. Tanner, County Surveyor, Newport	" 27
Torrisholme—Four Cottages	Monmouthshire County Council	Chas. F. Thompson, Architect and Surveyor, Lancaster	" 27
Lossiemouth—New Established Church	Robet Hand	J. H. Glennie, Solicitor, Lossiemouth	" 27
Bristol—Additions to Barton Hill Schools	Burial Board	W. A. Adams, Clerk, Guildhall, Bristol	" 27
Paisley—Extension of Sick-Room at Riccartbar Asylum	Infirmary Governors	W. D. McLennan, Architect, 96, High-street, Paisley	" 27
Chepstow—Seven Cottages	Corporation	J. P. C. Consterdine, 39, High-street, Chepstow	" 27
Nantyglo—Police Station	Great Western Railway Co.	Wm. Tanner, County Surveyor, Newport	" 27
Bettesdon—C.M. Sunday School	Guardians	R. Lloyd Jones, Architect, 14, Market-street, Carnarvon	" 27
Consett—House and Shop, Middle-street	Co-operative Society, Ltd.	W. S. Snell, M.S.A., Taylor-street, Consett	" 28
Bebington—Work Yard and Shed	Chesham Co-operative Society	John C. Ogle, Architect, 34, Hamilton-street, Birkenhead	" 28
Workington—Additions to Board Room	Bristol Town Council	F. W. Jackson, Secretary, Workington	" 28
Ruabon—Additions to the Acrefair Board School	Town Council	J. Morison and Son, Architects, King-street, Wrexham	" 28
Bootle—Electric Light Station, Pine-grove	School Board	J. A. Crowthier, Borough Engineer, Bootle	" 28
Llanharan—Station	Viscount Massereene and Ferrard	C. Mills, Secretary, Paddington Station, W.	" 28
Pool—Reseating and Renovating Wesleyan Chapel	Asylums Committee	Sampson Hill, Architect, Green-lane, Redruth	" 28
Chelsea, S.W.—Repairs to Infirmary, Cale-street	Guardians	Lansdell and Harrison, Architects, 38, Bow-lane, Cheapside	" 28
Limerick—Offices in Town Hall	Co-operative Society, Ltd.	William E. Corbett, 28, Glentworth-street, Limerick	" 28
Harrigate—Technical and Art School	Chesham Co-operative Society	W. J. Morley, F.R.I.B.A., 269, Swan-arcade, Bradford	" 28
Liverpool—Swimming-Bath, Green-lane Pumping Station	Bristol Town Council	Joseph Parry, Municipal Buildings, Liverpool	" 28
Bebington—Shed and Workyard	Town Council	J. E. Lloyd, Clerk, 24, Kingsland-road, Birkenhead	" 28
Ruabon—Alterations to Acrefair Board School	School Board	J. Morison and Son, Architects, King-street, Wrexham	" 28
Neath—Boiler and Exhauster Houses	Viscount Massereene and Ferrard	R. A. Browning, A.M.I.C.E., Gasworks, Neath	" 28
Chorley—Additions, Grain Warehouse	Asylums Committee	C. W. Bayley, Secretary, Hunt's Bank, Manchester	" 28
Roath—Temporary Buildings for Intermediate School	Guardians	David Shepherd, Clerk, 1, Frederick-street, Cardiff	" 28
Abergavenny—Temporary Wooden Buildings (100 Asylum Patients)	Chesham Co-operative Society	B. J. Francis, Architect, 12, Cross-street, Abergavenny	" 29
Heaton Junction—Waggon Repairing Shops, Offices, &c.	Bristol Town Council	C. N. Wilkinson, Secretary, York	" 29
Manchester—Alterations to Relief Offices, New Bridge-street	Town Council	Geo. Macdonald, Clerk, New Bridge-street, Manchester	" 29
Wandsworth—Nurses' Home at Infirmary, St. John's Hill	School Board	Lansdell and Harrison, Architects, 38, Bow-lane, Cheapside, E.C.	" 29
Bootle—Lodge, Derby Park	Viscount Massereene and Ferrard	J. H. Farmer, Town Clerk, Bootle	" 29
Oban—Additions to West Highland Cottage Hospital	Asylums Committee	G. Woulfe Brennan, Architect, Oban	" 29
Chorley—Grain Warehouse	Guardians	C. W. Bailey, Secretary, Hants Bank, Manchester	" 29
Kinloch Rannoch—Hotel (Twenty-four Bedrooms)	Chesham Co-operative Society	D. MacDiarmid, Bank of Scotland, Aberfeldy	" 29
Rawtenstall—Two Villas, Haslinden-road	Bristol Town Council	F. J. Hobson, Architect, Victoria Buildings, Rawtenstall	" 29
Abergavenny—Temporary Wooden Buildings	Town Council	B. J. Francis, Architect, 12, Cross-street, Abergavenny	" 29
Heaton Junction—Waggon-Repairing Shops	School Board	William Bell, Architect, Central Station, Newcastle-on-Tyne	" 29
London, S.E.—Mortuary at Lambeth Infirmary	Viscount Massereene and Ferrard	W. Thurnall, Clerk, Offices, Brook-street, Kennington, S.E.	" 30
Brymbo—Baptist Chapel	Asylums Committee	Wm. Jones, Secretary, 1, Hope-view, Brymbo	" 30
Broadway—Stores, Slaughter-House, Shop-Fronts, &c.	Guardians	Geo. H. Green, M.S.A., Architect, 159, High-road, Kilburn	" 30
Tarvit Park—Manse	Chesham Co-operative Society	David Storrar, Architect, Cupar, Fife	" 30
Bedminster—Foundations and Timber Jetties	Bristol Town Council	John M. McCurich, Docks Engineer, Cumberland Basin, Bristol	" 30
New Tredegar—Primitive Methodist Chapel and Schoolroom	Town Council	Rev. S. Buckley, 133, Commercial-road, New Tredegar	" 30
Andover—Alterations Free Library and School of Art	School Board	Thos. E. Longman, Town Clerk, Andover	" 30
Barnsley—Semi-Detached Villas, Victoria-street	Viscount Massereene and Ferrard	Wade and Turner, Architects, 10, Pitt-street, Barnsley	" 30
Blaenavon—Additions to Forge Side School	Asylums Committee	H. Parry, Clerk, Blaenavon	" 30
Brynamman—Additions to Siloam Chapel	Guardians	P. Jones, Pleasant View, Upper Brynamman	" 30
Newark—Science and Art Schools	Chesham Co-operative Society	J. Tidd Pratt, Hon. Secretary, Newark	" 30
Autrim—Two Semi-Detached Villas	Bristol Town Council	William J. Fennell, Architect, 11, Chichester-street, Belfast	July 1
Belhairs—Steading, Inn Farm	Town Council	J. Farquharson, 37, Westburn-row, Aberdeen	" 1
Corbeagh—Gate Lodge	School Board	J. O. Maynan, B.E., Corbeagh	" 1
Austerfield—Alterations to Board School	Viscount Massereene and Ferrard	John Walker, Clerk, Bawtry	" 1
Camrose—Rebuilding Congregational Church	Asylums Committee	D. E. Thomas, Architect, 8, Victoria-place, Haverfordwest	" 2
Canton, Cardiff—Hotel, Lansdowne-road	Guardians	Veall and Sant, Architects, Cardiff	" 2
Bideford—Rebuilding Old King o' Bells	Chesham Co-operative Society	R. T. Hookway, Architect, 12, Bridgeland-street, Bideford	" 2
Chester-le-Street—Administrative Block at Isolation Hospital	Bristol Town Council	H. Henderson, Pelton Cottage, Chester-le-street	" 2
Horton, near Epsom—Superstructure of Lunatic Asylum (for 2,000 Patients and Staff)	Town Council	G. T. Hine, Architect, 35, Parliament-street, S.W.	" 4
Kingston-on-Thames—New Offices adjoining Workhouse	School Board	William H. Hope, Architect, Portsmouth-rd., Kingston-on-Thames	" 4
Belfast—Extension, Electric Light Station, Abercorn Basin	Viscount Massereene and Ferrard	W. A. Currie, Secretary, Harbour Offices, Belfast	" 4
Arthurstown—Coastguard Station	Asylums Committee	Office of Public Works, Dublin	" 4
Eaglescliffe Junction—House	Guardians	Geo. Robson, 23, Linthorpe-road, Middlesbrough	" 4
Gloucester—Public Library, &c., Brunswick-road	Chesham Co-operative Society	Waller and Son, Architects, 17, College-green, Gloucester	" 4

BUILDINGS—continued.

Rhosgafan—Infant School	Llanwnda School Board	R. Lloyd Jones, Architect, 14, Market-street, Carnarvon	July 5
Southampton—Cart Shed	Corporation	George B. Naider, Town Clerk, Municipal Offices, Southampton	" 5
North Bierley—Porter's Lodge, &c.	Joint Hospital Board	Enoch Priestley, Holly Bank, Wibsey, Bradford	" 5
Haverfordwest—Vagrant Wards at Workhouse	Guardians	John James, Clerk, High-street, Haverford	" 5
Tottenham—North Eastern Hospital, St. Ann's-road	Metropolitan Asylums Board	T. Duncombe Mann, Clerk, Norfolk-street, Strand, W.C.	" 6
Kingston-on-Thames—Electricity Sub-Station, Coombe-road	Town Council	Harold A. Winsor, Town Clerk, Clatterin, Kingston-upon-Thames	" 7
Bury St. Edmunds—Chapel at Thingoe Workhouse	Board of Guardians	T. D. Atkinson, Architect, St. Mary's-passage, Carlisle	" 9
Grangemouth—Three Double Cottages	Co-operative Building Society	J. P. Mackenzie, Solicitor, Grangemouth	" 11
Muswell Hill, N.—Fire-Engine Station	Hornsey Urban District Council	F. D. Askey, Clerk, Southwood-lane, Highgate, N.	" 11
Dartford—Destructor House and Pair of Destructors, Gore Farm Hospital	Metropolitan Asylums Board	T. D. Mann, Clerk, Norfolk House, Norfolk-street, Strand, W.C.	" 14
Rochester—Schools (760 children), Gordon-road, Strood	School Board	Apsley Kennette, Clerk, Guildhall, Rochester	" 14
Bradwell, Essex—Coastguard Buildings	Admiralty	Director of Works Department, Northumberland-avenue, S.W.	" 15
Honley—Additions to Cottage, Offices, &c.	Joint Sewerage Board	Alfred J. Slocome, Clerk, Town Hall, Huddersfield	" 19
Cushendall—Presbyterian Church	Government of Ecuador	W. J. Fennell, Architect, 11, Chichester-street, Belfast	" 19
Guayaquil—Custom House	Municipal Authority	The Brazilian Legation, London	Aug. 31
Belem—Cattle Pens, Abattoir, and Two Markets		Fred Mitchell, Architect, Safe Deposit Chambers, Leeds	Oct. 24
Leeds—Alterations to North Tavern, North-street	Edward Smith	J. V. Brennan, Architect, 21, Waring-street, Belfast	"
Belfast—Remodelling the Licensed Premises, Old Lodge-road	Elland-cum-Greetland School Board	Chas. E. Butcher, Architect, 3, Queen-street, Colchester	"
Colchester—Villa Residence, Maldon-street	W. H. Lawton	Herbert W. Booth, Architect, King Cross, Halifax	"
Elland—Additions to South-end Schools	Mrs. Wood	Wimperis and Arber, Architects, 25, Sackville-street, Piccadilly, W.	"
London, W.—Pulling-down Mansion, No. 35, Dover-street	W. H. Priest	George A. Hammond, Architect, Rochdale	"
Castleton—Eight Shops with Houses and Three Lock-up Shops	Richard H. Monkhouse	D. Hardman, Architect, Silver-street, Bury	"
Greenmount—Two Semi-detached Houses	Executors of C. H. James	Joseph Hall, Parkgate, Wigton, N.B.	"
Wigton—Barn	Roberts, Mart, and Co.	Robert Walker, F.R.I.B.A., Architect, Windermere	"
Loughrigg—Billiard-room and Library at Brunt How	H. R. Cousins	R. Dodds, Civil Engineer, 19, Baxter-gate, Doncaster	"
Goldthorpe—Sixteen Houses	Vicar and Committee	J. G. Stallebrass, Architect, North-street, Peterborough	"
Peterborough—Two Houses in Parliament-street	Carlisle Lodging House Co.	Joseph Graham, Architect, Bank-street, Carlisle	"
Longtown—Additions to Licensed Premises, High-street	Leonard Chorley	R. Tate, Blackpark, Manorhamilton	"
Manorhamilton—Rebuilding Cherrybrook House	Executors of C. H. James	E. A. Johnson, M.S.A., Architect, Abergavenny	"
Pandy—Repairs to Great Goutre Farm Buildings	W. H. Priest	E. Hill, 20, Lifton-street, Leeds	"
Holbeck—Three-Story Stable and Hay-Loft	Nottingham Forest Football Club	Amble and Bowman, Architects, 9, Park-place, Leeds	"
Leeds—Mill Extension, East-street	J. P. O'Ferrall	J. E. Goodacre, Architect, 4, Stockwell-gate, Mansfield	"
Shirebrook—Wesleyan School Chapel	John Kenney	Bland and Bown, Architects, North Park-row, Harrogate	"
Harrogate—House and Schools, Leadhall-lane	W. Hancock and Co.	Thomas Nuttall, C.E., Architect, 20, Market-street, Bury	"
Bury, Lancs.—Eight Houses in Parsonage-street	F. McKernan	Teifer Smith, M.S.A., Architect and Surveyor, Builth, Wells	"
Strata Florida, Cardiganshire—New Church	Michael Martin	T. H. Cheate, Hon. Secretary, Burford, Oxon	"
Burford, Oxon—Cottage Hospital	W. Simmons	H. Higginson, M.S.A., Carlisle	"
Carlisle—Lodging House, Lowther-street	William Young	Mrs. Crossland, Upper Green, West Ardsley	"
West Ardsley—Houses at Tingley Common	Mrs. Cawthorn	John Hutton, M.S.I., Architect, Kendal	"
Sedburgh—Rebuilding Bull Hotel	Liverpool Building Co.	C. R. Dalgleish, Architect, Central Chambers, Wellington, Salop	"
Radbrook—Shropshire Technical School for Girls	Paper Works Co.	E. A. Johnson, M.S.A., Architect, Abergavenny	"
Pandy—Additions to Great Goutre Farm Buildings	Sculcoates Rural District Council	J. E. Goodacre, Architect, Stockwell-gate, Mansfield	"
Newstead—Wesleyan Chapel	Corporation	J. R. Dodds, Surveyor, 19, Baxter-gate, Doncaster	"
Goldthorpe—Sixteen Houses	Urban Council	Judson and Moore, Architects, Keighley	"
Keighley—Shops, Arcade, and Offices, North-street	Hunts County Council	Harry Gill, Architect, Cobden Chambers, Pelham-st., Nottingham	"
Nottingham—Pavilion, Trent Bridge	Caledonian Railway Company	John Haggas, Architect, North-street, Keighley	"
Oxenhope—Two Houses and Shop, Station-road	Town Council	J. O. Moynan, B.E., Corbeagh	"
Corbeagh—Gate Lodge	Corporation	J. Heggas, Architect, North-street, Keighley	"
Keighley—Four Houses, Park Wood-street	William Young	W. J. Moore, Architect, Whitehall Buildings, Belfast	"
Belfast—Block of Dwellings, Falls-road	Mrs. Cawthorn	W. T. Goodfellow, Hon. Sec., Wincanton, Somerset	"
Wincanton—Grand Stand (1,000 to 1,500 people)	Liverpool Building Co.	Watkins and Brown, Architects, Dock-street, Newport	"
Abersychan—Additions to Unicorn Inn	Paper Works Co.	Thomas Nuttall, Architect, 20, Market-street, Bury	"
Bury—Eight Houses, Parsonage-street	Sculcoates Rural District Council	W. J. Moore, Architect, Whitehall Buildings, Belfast	"
Belfast—Extension of Licensed Premises, York-road	Corporation	Wm. Spencer, Victoria-road, Kirkstall, Leeds	"
Kirkstall—Eight Houses and Two Shops	Urban Council	S. Shirt, Mount Pleasant, Hurst, Lancs	"
Hurst—Slaughter-House and Stables	Hunts County Council	Sugden and Sons, Architects, Leek	"
Failsworth—Alterations, Secular Sunday-School	Caledonian Railway Company	T. Ernest Crossling, Architect, Stanley, R.S.O., Co. Durham	"
South Moor—Block of Property	Town Council	H. Smith, Architect, 135, Leyland-road, Burnley	"
Burnley—Extending Brownside Shed	Corporation	Goodey and Cressall, Architects, Victoria Chambers, Colchester	"
Halstead—House, Colchester-road	Urban Council	C. Page, Grocer, Gosberton	"
Gosberton—Alterations to Wesleyan Sunday-School	Corporation	James Bell, Town Clerk, Town Hall, Leicester	"
Leicester—Isolation Hospital	Urban Council	Wm. Hull, Architect, 12, St. Giles's-street, Northampton	"
Hanslope—Alterations to Schools	Hunts County Council	H. Higginson, Architect, Carlisle	"
Halfwhistle—House and Shop	Caledonian Railway Company	Perkin and Bulmer, Architects, Toronto-street, Leeds	"
Leeds—All Souls' Mission Room	Town Council	T. Ernest Crossling, Architect, Stanley, R.S.O., Co. Durham	"
Hobson—Two Dwelling-houses	Corporation	S. S. Bayley, Post Office, Springfield, near Dudley	"
Rowley Regis—Church Restoration	Urban Council	Settle and Farmer, Architects, Ulverston	"
Dalton—Bank	Hunts County Council	J. Phillips, Architect, Sirhowy House, Maesywmmmer	"
New Tredegar—House and Business Premises			"

ENGINEERING.

Burnley—Tanks	Paper Works Co.	The Secretary, Paper Works Co., Burnley	June 25
Sutton-on-Hull—Extension of Water-Mains	Sculcoates Rural District Council	William H. Wellsted, Engineer, Prince's Dock Chambers, Hull	" 25
Salford—Steam Fire-Engine	Corporation	Saml. Brown, Town Clerk, Salford	" 27
Beverley—Gasholder and Tank, E. R. Asylum	Visiting Committee	C. W. Hobson, Clerk, Newbegin, Beverley	" 28
Bethnal Green—Electricity Plant at Infirmary, Palestine-place	Board of Guardians	Giles, Gough, & Trollope, Archts, 23 Craven-st., Charing Cross, W.C.	" 28
Cardiff—Boilers	Corporation	Nappelbee, Electrical Engineer, Cardiff	" 28
Barry—High-Level Reservoir	Gas and Water Committee	E. W. Waite, A.M.I.C.E., Barry, Glam.	" 30
Glenarnock—Storage Tanks and Pipes	Ayrshire County Council	John Lusk, Clerk, Dalry	" 30
Bristol—Bridge Foundations	Docks Committee	J. M. McCurric, C.E., 10, Queen-square, Bristol	" 30
Madras—Utilisation of Water of Periyar Lake	Urban Council	Chief Engineer for Irrigation, Madras	July 1
Linslade—Water Supply	Hunts County Council	R. I. Platten, Clerk, Linslade, Leighton Buzzard	" 1
Stanground—Reconstruction of Horsey County Bridge	Caledonian Railway Company	County Surveyor, 151, High-street, Huntingdon	" 2
Radomir—Railway from Radomir to Kustendil and the Turkish Frontier	Town Council	Commercial Department of the Foreign Office	" 4
Grangemouth—Dock Extension	Corporation	Secretary Caledonian Railway, 302, Buchanan-street, Glasgow	" 4
Stockport—Oil-Tank, &c.	Urban Council	S. Meunier, Engineer, Stockport	" 6
St. Helens—Pumping Plant (to raise 1½ million gallons per day)	Corporation	J. J. Lackland, A.M.I.C.E., Water Engineer, Town Hall, St. Helens	" 12
Newbigging Hill—Waterworks	Asylums Committee	R. Addison Smith, Secretary, 19, Heriot-row, Edinburgh	"

FENCING AND WALLS.

Wood Green, N.—Undimble Iron Fencing	Urban District Council	J. W. Britton, Clerk, Town Hall, Wood Green	June 25
Lacock—Iron Fencing to Cemetery	Corporation	Thomas Holloway, Surveyor, Chippingham	" 25
Ashton-under-Lyne—Rubble Wall along River Tame	Select Vestry	J. T. Earnshaw, Borough Surveyor, Town Hall, Ashton-under-Lyne	" 27
Liverpool—Wall and Iron Railings, Brownlow Hill	Corporation	H. J. Hagger, Parish Offices, Liverpool	" 27
Worcester—Wrought-Iron Fencing	Corporation	T. Caink, A.M.I.C.E., City Engineer, Guildhall, Worcester	" 30

FURNITURE AND FITTINGS.

Knutsford—Furnishing Board Room	Guardians of Bucklow Union	George Leigh, Clerk, Union Offices, Knutsford	June 27
Dagenham—Hospital Furniture, &c.	West Ham Corporation	Fred. E. Hilleary, Town Clerk, Town Hall, West Ham	" 27
Bexley Heath—Bedding, &c., for Heath Asylum	Asylums Committee, L.C.C.	R. W. Partridge, Clerk, Asylums Office, 21, Whitehall-plac, S.W.	July 6

PAINTING.

Falkirk—New High School	Burgh School Board	A. and W. Black, Architects, Falkirk	June 25
Hereford—Shire Hall	County Council	H. T. Wakelam, Shire Hall, Hereford	" 25
Leeds—All Schools	School Board	W. Packer, Clerk, School Board Offices, Leeds	" 25
Wolverhampton—School Board Offices, Higher Grade School, and Walsall-street School	School Board	T. H. Fleeming, 102, Darlington-street, Wolverhampton	" 25
Portsmouth—Cambridge and Hilsa Barracks	General Purposes Committee	R. E. Offices, Portsea	" 25
Alloa (N.B.)—New Matings	Guardians	George Younger and Son, Ltd., Brewers, Alloa	" 27
Maidenhead—Lodge, Grenfell Park	School Board	Percy Johns, Borough Surveyor, Guildhall, Maidenhead	" 27
Dewsbury—Six Terrace Houses and Outbuildings, Savile Town	Town Council	John H. Brearley, Architect, Hanover-street, Batley	" 27
Thrapston—Workhouse	General Purposes Committee	Gerald Hunnybun, Clerk, Thrapston	" 27
Keighley—Four Schools	Guardians	H. Midgley, Clerk, Keighley	" 27
Motley—Town Hall	School Board	W. E. Putnam, Borough Surveyor, Town Hall, Motley	" 27
Brighton—Municipal School of Art	Town Council	Francis J. Tillstone, Town Clerk, Town Hall, Brighton	" 27
Maidenhead—Guild hall	General Purposes Committee	Percy Johns, Borough Surveyor, Guildhall, Maidenhead	" 28
Eston—Grange-town Board School	Eston School Board	H. J. Parrington, Clerk, 7, Queen's-terrace, Middlesbrough	" 29
Reading—Workhouse	Guardians	Charles Kift, Clerk, Board Room, Thorn-street, Reading	" 29
Hull—Thirty-Two Schools	School Board	W. Botterill, Architect, 23, Parliament-street, Hull	" 29
Tudhoe—Board Schools	School Board	Sam. Adams, Clerk, School Board Offices, Bishop Auckland	" 30
Dartmouth—Exterior of House, Old Butterwalk	Town Council	T. O. Veale, Borough Surveyor, Castle View	" 30



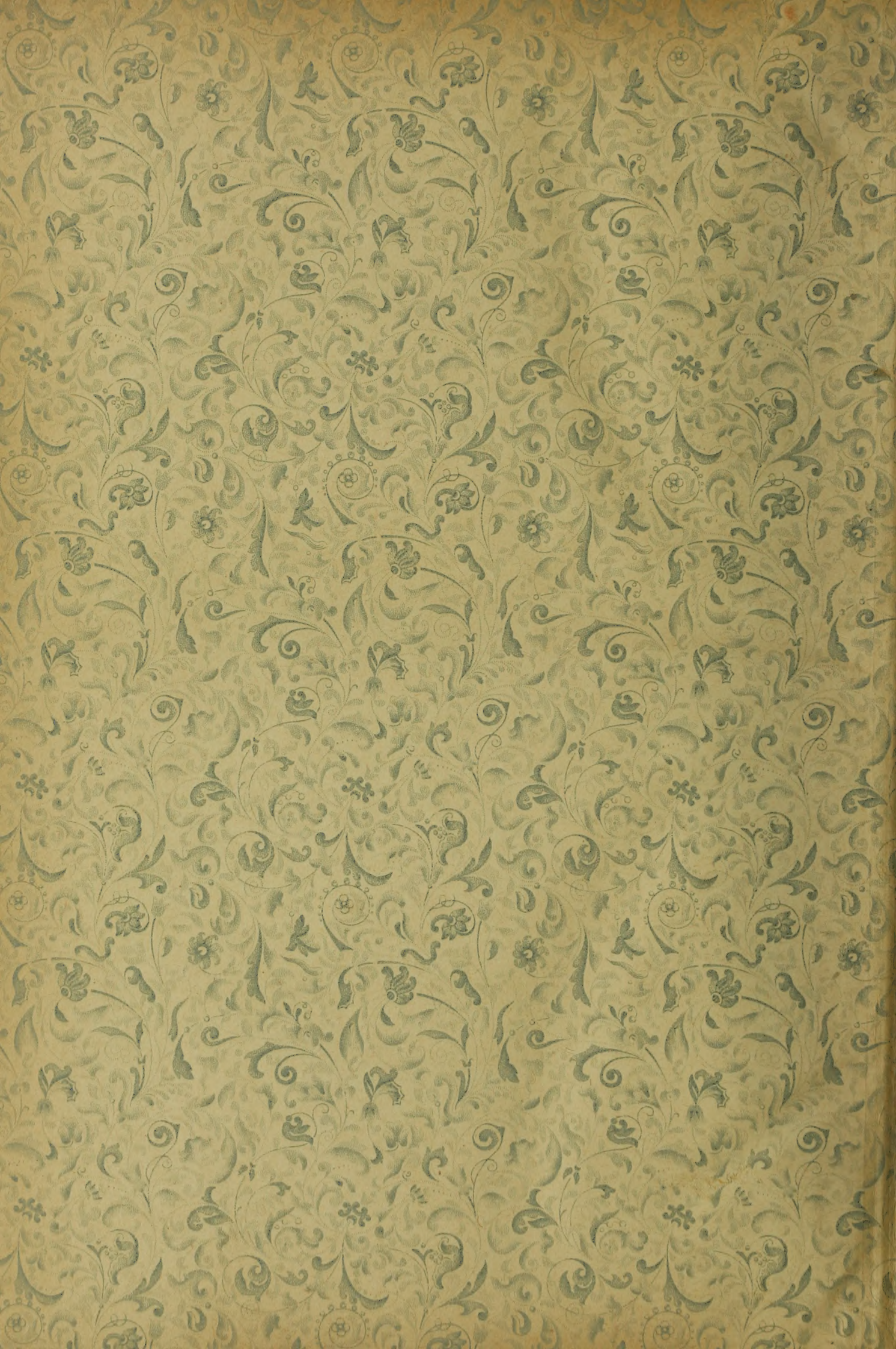



UNIVERSITY OF ILLINOIS-URBANA



3 0112 117956943